



(22) Date de dépôt/Filing Date: 2001/10/15

(41) Mise à la disp. pub./Open to Public Insp.: 2003/01/16

(62) Demande originale/Original Application: 2 452 987

(30) Priorité/Priority: 2001/07/05 (IL144158)

(51) Cl.Int./Int.Cl. *H04M 1/738* (2006.01)

(71) Demandeur/Applicant:
MOSAID TECHNOLOGIES INCORPORATED, CA

(72) Inventeur/Inventor:
BINDER, YEHUDA, IL

(74) Agent: HAMMOND, DANIEL

(54) Titre : PRISE DE TELEPHONE A ADAPTATEUR DE TELEPHONIE NUMERIQUE, ET RESEAU UTILISANT CETTE PRISE

(54) Title: TELEPHONE OUTLET WITH PACKET TELEPHONY ADAPTER, AND A NETWORK USING SAME

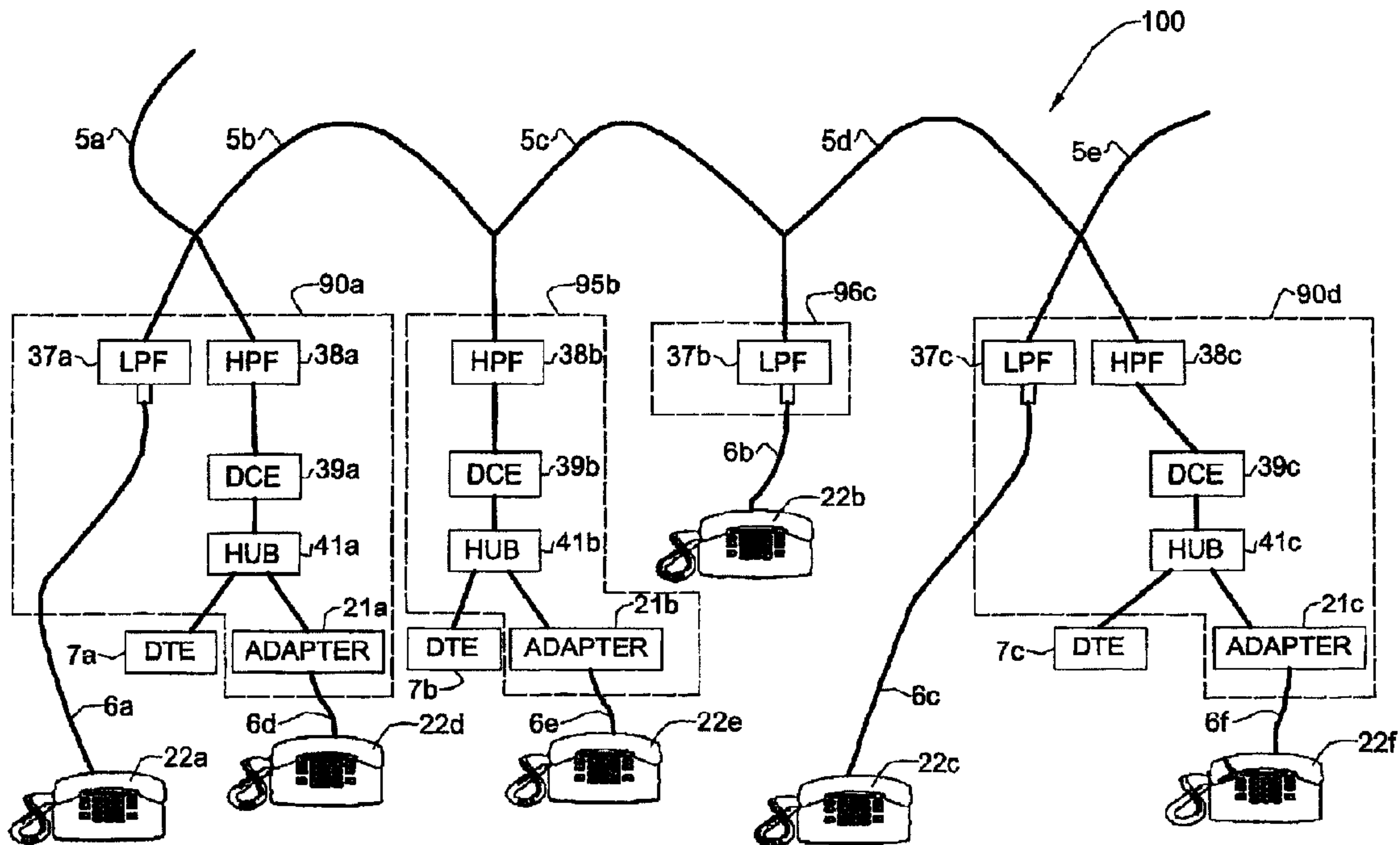

(57) Abrégé/Abstract:

An outlet (75) for a Local Area Network (80) (LAN), containing an integrated adapter (21) that converts VoIP to and from analog telephony, and a standard telephone jack (72) (e.g. RJ-11 in North America) for connecting an ordinary analog (POTS) telephone set. Such an outlet allows using analog telephone sets in a VoIP environment, eliminating the need for an IP telephone set or external adapter. The outlet may also include a hub (31a, 31c) that allows connecting both an analog telephone set (22a, 22c) via an adapter (21a, 21c), as well as retaining the data network connection, which may be accessed by a network jack (73a, 73c). The invention may also be applied to a telephone line-based data networking system. In such an environment, the data networking circuitry as well as the VoIP/POTS adapters are integrated into a telephone outlet, providing for regular analog service, VoIP telephony service using an analog telephone set, and data networking as well. In such a configuration, the outlet requires two standard telephone jacks and a data-networking jack. Outlets according to the invention can be used to retrofit existing LAN and in-building telephone wiring, as well as original equipment in new installation.

ABSTRACT

An outlet (75) for a Local Area Network (80) (LAN), containing an integrated adapter (21) that converts VoIP to and from analog telephony, and a standard telephone jack (72) (e.g. RJ-11 in North America) for connecting an ordinary analog (POTS) telephone set. Such an outlet allows using analog telephone sets in a VoIP environment, eliminating the need for an IP telephone set or external adapter. The outlet may also include a hub (31a, 31c) that allows connecting both an analog telephone set (22a, 22c) via an adapter (21a, 21c), as well as retaining the data network connection, which may be accessed by a network jack (73a, 73c). The invention may also be applied to a telephone line-based data networking system. In such an environment, the data networking circuitry as well as the VoIP/POTS adapters are integrated into a telephone outlet, providing for regular analog service, VoIP telephony service using an analog telephone set, and data networking as well. In such a configuration, the outlet requires two standard telephone jacks and a data-networking jack. Outlets according to the invention can be used to retrofit existing LAN and in-building telephone wiring, as well as original equipment in new installation.

**Telephone Outlet with Packet Telephony Adapter,
and a Network Using Same**

FIELD OF THE INVENTION

The present invention relates to the field of packet telephony, and, more specifically, to the use of packet telephony within a Local Area Network (LAN) over wiring simultaneously used for analog telephony.

5 BACKGROUND OF THE INVENTION

Analog Telephone Network

Analog telephony, popularly known as "Plain Old Telephone Service" ("POTS") has been in existence for over 100 years, and is well-designed and well-engineered for the transmission and switching of voice signals in the 3-4
10 KHz portion (or "band") of the audio spectrum. The familiar POTS network supports real-time, low-latency, high-reliability, moderate-fidelity voice telephony, and is capable of establishing a session between two end-points, each using an analog telephone set.

The terms "computer" and "personal computer" ("PC") as used herein
15 include workstations and other data terminal equipment (DTE) with interfaces for connection to a local area network. The term "telephone set" as used herein includes any device which can connect to a Public Switch Telephone Network ("PSTN") using analog telephone signals, non-limiting examples of which are fax machines, automatic telephone answering machines, and dial-up modems.

Outlets

The term "outlet" herein denotes an electro-mechanical device, which enables connection to wiring installed within a building. Outlets are permanently connected to the wiring, and allow easy connection of external units as required to such wiring, commonly by means of an integrated, built-in connector. The outlet is normally mechanically attached to, or mounted in, the wall. Non-limiting examples of common outlets include: telephone outlets for connecting telephone sets; CATV outlets for connecting television sets, VCR's, and the like; and electrical outlets for connecting power to electrical appliances.

10 LAN Environment

A development associated with the Internet is packet telephony. Packet telephony involves the use of a packet based network (commonly using the Internet Protocol, or IP) for communicating telephonic and related data, which may include sound, images, motion pictures, multimedia and any combinations thereof, in addition to voice content. In place of a pair of telephones connected by switched telephone lines as in analog telephony, packet telephony typically involves the use of an IP-telephone at one or both ends of the telephony link, with the telephonic information transferred over a packet network using packet switching and packet routing techniques, as exemplified by the Internet.

20 Recently, a solution for combining both telephony and data communications into a single network is offered by the Voice-Over-Internet-Protocol (VoIP) approach. In this technique, telephone signals are digitized and carried as data across the LAN. Such systems are known in the art.

Fig. 1 shows a typical LAN-based telephony environment 10. Such a network, commonly using 10BaseT or 100BaseTX Ethernet IEEE802.3 interfaces and topology uses a hub 11 as a concentrating device, into which all devices are connected. Devices are connected to hub 11 by data connectors 14a, 14b, and 14c, which are housed within network outlets 15a, 15b, and 15c respectively via cables 13a, 13b, and 13c respectively. Data connectors 14a, 14b,

and 14c may be, for example, type RJ-45; and cables 13a, 13b, and 13c may be, for example, Category 5 cabling. The telephony portion of network 10 uses IP telephones 17a, 17b, and 17c, which connect to network connectors 14a, 14b, and 14c via cables 16a, 16b, and 16c, respectively. A server 12 may also be
5 connected to hub 11, and can perform the IP-PBX functionality, as well as other server functions as applied in the art.

Although Fig. 1 refers to the hub 11 as a concentrating device, it is understood that any type of device having multiple network interfaces and supporting a suitable connectivity can be used, non-limiting examples of which
10 include a shared hub, switch (switched hub), router, and gateway. Hence, the term "hub" used herein denotes any such device. Furthermore, the hub 11 can be any packet based network, either in-building or distributed, such as LAN or the Internet.

In order to employ VoIP in network 10, specific IP telephones 17a, 17b,
15 and 17c must be used. Such telephones are expensive, require connection to a power outlet (or other power supply) and are not yet common in the marketplace. This factor has encouraged the availability of adapters for bridging between IP networks and PSTN equipment. Specifically, adapters enabling the usage of POTS telephone sets in an IP environment are available in the market, allowing
20 the use of common and low-price legacy POTS telephone sets to be used in a VoIP environment.

Fig. 2 shows a network 20 using POTS telephone sets in a VoIP environment. Basically, network 20 uses the same network infrastructure as network 10 (Fig. 1). However, instead of IP telephones 17a, 17b, and 17c, POTS
25 telephone sets 22a, 22b, and 22c are used, connected via cables 6a, 6b and 6c respectively to VoIP / PSTN adapters 21a, 21b, and 21c, respectively, which in turn are respectively connected to network outlets 15a, 15b, and 15c via cables 22a, 22b, and 22c respectively. Such a configuration affords the benefits of IP telephony, but allows the use of common and inexpensive POTS telephone sets.

Although network 20 facilitates the employment of common, low-cost standard legacy POTS telephone sets, adapters 21a, 21b, and 21c are necessary, making installation and maintenance complex, and requiring additional equipment, connections, and cables (e.g. cables 22). Furthermore, such adapters
5 require a power connection, further complicating installation, use, and maintenance.

Furthermore, although Fig. 1 and Fig. 2 show networks which are used solely for telephony, LANs today are intended and used principally for data communication, to connect Data Terminal Equipment (DTE) devices (such as
10 desktop personal computers, printers). In some cases, the number of outlets 15 (or connectors 14) may not suffice for both telephony and data applications. For example, this may be the case in an office where each work area has a single network connection via a single outlet 15 having single connector 14. In this case, a hub (or other multi-port unit) must be connected to expand to multiple
15 network connections. Fig. 3 shows such a configuration in a prior-art network 30. In order to allow both adapter 21a and DTE 7a to share network outlet 15a via connector 14a, a hub 31a is added. Similarly, a hub 31c is added, facilitating the connection of both adapter 21c and DTE 7c to a single network connection via outlet 15c via connector 14c. Thus, in such a configuration, additional hubs 31a
20 and 31c must be added, introducing additional complexity in installation and maintenance.

EP 0824298 to Harper is an example of a prior art network 30 using ATM as the network protocol. Similarly, UK Patent GB 2352360 also refers to telephony carried over ATM cells in a digital broadcast environment.

25 US Patent 5,530,894 to Farrell *et al.* discloses an example of a specific method and system that allows analog telephony to be routed as part of a digital network, using dedicated time division switching circuitry involving data link layers handling.

4a

US Patent 6,130,893 to Whittaker *et al.* is another example showing a prior art network 30 in a building. An external terminal adapter 20 allows additional telephone lines using standard analog telephones sets (POTS) to be added. To this end, the terminal adapter 20 is provided with a jack 47 and an output 45 connected to a Media Access Control Unit (MACU) 52, which outputs to a Packet Decoder 54 and receives an input from a Packet Encoder 66. An external power supply must be provided for energizing active components within the terminal adapter such as the MACU, packet decoder and encoder and various active components. As noted above, this further complicates installation, use, and maintenance of such devices.

Home Networking

In-home telephone service usually employs two or four wires, to which telephone sets are connected via telephone outlets.

Fig. 4 shows the wiring configuration of a prior-art telephone system including a network 40 for a residence or other building, wired with a telephone line 5. The telephone line 5 consists of single wire pair which connects to a junction-box 34, which in turn connects to a Public Switched Telephone Network (PSTN) 41 via a cable 33, terminating in a public switch 32, which establishes and enables telephony from one telephone to another. The term "analog telephony" herein denotes traditional analog low-frequency audio voice signals typically under 3KHz, sometimes referred to as "POTS" ("Plain Old Telephone Service"), whereas the term "telephony" in general denotes any kind of telephone service, including digital service such as Integrated Services Digital Network (ISDN). The term "high-frequency" herein denotes any frequency substantially above such analog telephony audio frequencies, such as that used for data. ISDN typically uses frequencies not exceeding 100KHz (typically the energy is concentrated around 40KHz). The term "telephone line" herein denotes electrically-conducting lines which are intended primarily for the carrying and distribution of analog telephony, and includes, but is not limited to, such

1341000 40.01 000

AMENDED SHEET

Emp. no. 02/01/2002 02-22

Emp. no. 02/01/2002

electrically-conducting lines which may be pre-existing within a building and which may currently provide analog telephony service. The term "telephone device" herein denotes, without limitation, any apparatus for telephony (including both analog telephony and ISDN), as well as any device using telephony signals, such as fax, voice-modem, and so forth.

The junction box 34 is used to separate the in-home circuitry from the PSTN and is used as a test facility for troubleshooting as well as for new wiring in the home. A plurality of telephones may connect to telephone lines 5 via a plurality of telephone outlets 35a, 35b, 35c, and 35d. Each outlet has a connector (often referred to as a "jack"), denoted in Fig. 4 as 36a, 36b, 36c, and 36d, respectively. In North-America, RJ-11 is commonly used for a jack. Each outlet may be connected to a telephone unit via a "plug" connector that inserts into the jack.

Network 40 is normally configured into a serial or "daisy-chained" topology, wherein the wiring is connected from one outlet to the next in a linear manner, but other topologies such as star, tree, or any arbitrary topology may also be used. Regardless of the topology, however, the telephone wiring system within a residence always uses wired media: two or four copper wires along with one or more outlets which provide direct access to these wires for connecting to telephone sets.

It is often desirable to simultaneously use existing telephone wiring simultaneously for both telephony and data networking. In this way, establishing a new local area network in a home or other building is simplified, because there is no need to install additional wiring. U.S. Patent 4,766,402 to Crane (hereinafter referred to as "Crane") teaches a Local Area Network over standard two-wire telephone lines, but does not simultaneously support telephony.

As another example, relevant prior-art in this field is disclosed in U.S. Patent 5,896,443 to Dichter (hereinafter referred to as "Dichter"). Dichter suggests a method and apparatus for applying a frequency domain / division

multiplexing (FDM) technique for residential telephone wiring, enabling the simultaneous carrying of telephony and data communication signals. The available bandwidth over the wiring is split into a low-frequency band capable of carrying an analog telephony signal, and a high-frequency band capable of carrying data communication signals. In such a mechanism, telephony is not affected, while a data communication capability is provided over existing telephone wiring within a home.

The concept of frequency domain / division multiplexing (FDM) is well-known in the art, and provides means of splitting the bandwidth carried by a wire into a low-frequency band capable of carrying an analog telephony signal and a high-frequency band capable of carrying data communication or other signals. Such a mechanism is described, for example, in U.S. Patent 4,785,448 to Reichert *et al.* (hereinafter referred to as "Reichert"). Also widely used are xDSL systems, primarily Asymmetric Digital Subscriber Loop (ADSL) systems.

In addition to illustrating a residential telephone system, Fig. 4 also shows the arrangement of a Dichter network. Network 40 serves both analog telephones and provides a local area network of data units. Data Terminal Equipment (DTE) units 7a, 7b, and 7c are connected to the local area network via Data Communication Equipment (DCE) units 39a, 39b, and 39c, respectively. Examples of Data Communication Equipment include, but are not limited to, modems, line drivers, line receivers, and transceivers (the term "transceiver" herein denotes a combined transmitter and receiver), which enables communication over telephone line 5. DCE units 39a, 39b, and 39c are respectively connected to high pass filters (HPF) 38a, 38b, and 38c, which allow access to the high-frequency band carried by telephone line 5. In order to avoid interference to the data network caused by the telephones, low pass filters (LPF's) 37a, 37b, and 37c are added to isolate the POTS carrying band, so that telephones 22a, 22b, and 22c connects to telephone line 5 for providing PSTN.

Furthermore, a low pass filter may also be connected to Junction Box 34 (not shown in the figure), in order to filter noise induced from or to PSTN wiring 33.

Fig. 5 shows a telephone line-based LAN 50 wherein the data network is used for carrying both VoIP telephony and regular DTE network data. Hubs 31a, 31b, and 31c allow connecting respective DTE units 7a, 7b, and 7c as well as respective IP telephones 17a, 17b, and 17c to respective single network connections via DCE units 39a, 39b, and 39c. Analog telephones 22a, 22b, and 22c are also shown connected via respective low pass filters (LPF's) 37a, 37b, and 37c to the telephone outlets 35a, 35b, and 35c. Thus, the analog telephones are connected directly to the analog telephone line 5.

In order to eliminate the need for IP telephones 17a, 17b, and 17c, and to permit using analog telephone sets 22a, 22b, and 22c instead, adapters 21a, 21b, and 21c (Fig. 3) must be added, as described previously. Fig. 6 shows a network 60, where this is done. IP telephones 17a, 17b, and 17c of network 50 are replaced by analog telephone sets 22d, 22e, and 22f, respectively, connected to hubs 41a, 41b, and 41c, respectively, via adapters 21a, 21b, and 21c respectively.

Fig. 6 demonstrates the complexity of such a configuration. At least three types of external devices are required: DCE units 39a, 39b, and 39c; hubs 41a, 41b, and 41c; and adapters 21a, 21b, and 21c. Each of these devices usually requires a separate power connection, which adds to the complexity of the connections. Thus, such a network is complex and difficult to install, operate, and maintain. In the prior art, it is suggested to integrate the DCE, HPF, and LPF components into outlets 35a, 35b, and 35c. Nevertheless, external hubs 41a, 41b, and 41c, as well as adapters 21a, 21b, and 21c still impose additional complexity in such a network.

Similarly, WO 01/28215 to Bullock et al. describes a system used to carry analog telephony over existing power lines within a premises. This solution requires many external units such as base unit 102, PLC I/F 103, PLC I/F 106

and extension unit 107. The requirement for such multiple and different units adds complexity and makes the installation cumbersome and difficult.

There is thus a widely recognized need for, and it would be highly advantageous to have, a means for allowing the use of analog (POTS) telephone sets in LAN / VoIP environments without requiring additional external devices or power sources and allowing easy installation, operation, and maintenance. This goal is met by the present invention.

SUMMARY OF THE INVENTION

The present invention makes it easy and convenient to use analog ("POTS") telephone sets in a packet telephony environment, including, but not limited to, IP telephony via VoIP technology. The invention provides an outlet for a Local Area Network (LAN), with an integrated analog/VoIP adapter. The outlet has a standard analog telephone jack (e.g. RJ-11 in North America) allowing an analog telephone set to be directly connected to, and used with, a packet telephony system.

In a first embodiment, an outlet according to the present invention is used with an ordinary LAN environment, such as Ethernet 10BaseT (IEEE802.3). The outlet allows connecting analog telephone sets to the LAN via the integrated analog/VoIP adapter, supports analog telephony over the LAN media, and can also support a standard network data connection using an integrated multi-port unit (e.g. hub, switch, or router). For standard network data connections, the outlet also includes a data networking jack (e.g. RJ-45 if 10BaseT or 100BaseTX is used) connected to a port.

In another embodiment, the outlet enables a LAN to be based on in-building telephone wiring, in a home or Small Office / Home Office (SoHo) environment. A packet-based LAN is implemented, and outlets according to the present invention serve as both telephone outlets and network outlets. This
5 allows for direct and convenient connection of analog telephone sets to VoIP packet telephony over the data network. In such an arrangement, the regular analog telephony service remains unaffected, because the low-frequency analog portion of the spectrum is isolated by the FDM technique. As noted above, the outlet may also support a network data connection, using an integrated multi-port
10 unit (e.g. hub, switch or router), and in this case also includes a data network jack (e.g. RJ-45 if 10BaseT or 100BaseTX is used) connected to a port.

Outlets according to the present invention can be installed as part of an original network installation, as a retrofit to an existing network, or to set up a network over existing telephone wiring.

15 **BRIEF DESCRIPTION OF THE DRAWINGS**

The invention is herein described, by way of non-limiting example only, with reference to the accompanying drawings, wherein:

Fig. 1 shows a prior art local area network supporting IP telephony.

20 Fig. 2 shows a prior art local area network supporting IP telephony, using analog telephone sets.

Fig. 3 shows a prior art local area network supporting both IP telephony using analog telephone sets and DTE connectivity.

Fig. 4 shows a prior art local area network over telephone lines.

25 Fig. 5 shows a prior art local area network over telephone lines supporting both IP telephony and DTE connectivity.

Fig. 6 shows a prior art local area network over telephone lines supporting both IP telephony using analog telephone sets and DTE connectivity.

Figs. 7a and 7b show schematically outlets according to different embodiments of the invention.

Fig. 8 shows a local area network supporting both IP telephony using analog telephone sets and DTE connectivity, employing outlets according to the present invention.

Fig. 9 illustrates an outlet supporting analog telephony and packet telephony according to the present invention.

Fig. 10 illustrates a local area network over telephone lines supporting both IP telephony using analog telephone sets and DTE connectivity, employing outlets according to the present invention.

Fig. 11 illustrates a first outlet according to the present invention for providing life-line telephone capability for a telephone normally used in packet telephony.

Fig. 12 illustrates a second outlet according to the present invention for providing life-line telephone capability in conjunction with a data network, where analog telephone signals are provided via a separate conductor.

Fig. 13 illustrates a third outlet according to the present invention for providing life-line telephone capability in conjunction with a data network, where analog telephone signals are separated using FDM.

Fig. 14 illustrates a global network connected via a gateway to a local network existing within a building, and which provides packet telephony services to analog telephones via in-building outlets according to the present invention.

Fig. 15 illustrates a general form of an outlet according to the present invention, which can serve in various wired network environments, such as CATV and electrical power networks.

DETAILED DESCRIPTION OF THE INVENTION

The principles and operation of a network according to the present invention may be understood with reference to the drawings and the accompanying description. The drawings and descriptions are conceptual only. In
5 actual practice, a single component can implement one or more functions; alternatively, each function can be implemented by a plurality of components and circuits. In the drawings and descriptions, identical reference numerals indicate those components that are common to different embodiments or configurations.

Figs. 7a and 7b shows schematically outlets 70 and 75 according to two
10 different embodiments of the invention. As shown in Fig. 7b, the outlet 75 includes a VoIP to analog telephony adapter 21. Outlet 75 connects to data network wiring via a connector 71. Connector 71 is preferably located at the rear of outlet 75, where outlet 75 mechanically mounts to an interior wall of a building. Outlet 75 connects to an analog telephone set via a jack 72. Jack 72 is
15 preferably located at the front, or "panel" of outlet 75, which is visible when outlet 75 is mounted on an interior wall of a building. Jack 72 can be an RJ-11 jack, which is commonly used in North America for analog telephony. Outlet 75 allows connecting an analog telephone set (via jack 72) to the data network via connector 71, bridged by an adapter 21. As shown in Fig. 7a, the outlet 70 also
20 includes the adapter 21, but further includes a hub 31 and a data jack 73, which is connected directly to hub 31. Because of the hub 31, the outlet 70 allows both an analog telephone (via jack 72) and a data unit (via jack 73) to be connected to the data network via connector 71. Preferably, both jack 72 and jack 73 are located at the front, or "panel" of outlet 70.

25 Fig. 8 shows a Local Area Network (LAN) 80 according to the present invention. Basically, the infrastructure of network 80 is the same as that of prior art network 10 (Fig. 1), in which hub 11 is connected in a 'star' topology to various end units via network wiring 13a, 13b, and 13c, and outlets 15a, 15b,

and 15c. However, according to the present invention, outlets 15a, 15b, and 15c of the prior art network 10 are replaced by outlets 70a, 75b, and 70c, respectively, each of which contain an adapter as previously described with reference to Figs. 7a and 7b of the drawings. For example, outlet 75b has a built-in adapter 21b. Outlet 75b allows for connection of an analog telephone set 22b using a cable 6b. Similarly, outlets 70a and 70c allow analog telephone sets 22a and 22c, respectively, to be connected to the network via cables 6a and 6c, respectively, using internal adapters 21a and 21c, respectively. Hubs 31a and 31c integrated within outlets 70a and 70c, respectively, allow for the connection of DTE units 7a and 7c, respectively, to the network, in addition to analog telephones 22a and 22c, respectively. Network 80 allows networking of both DTE units 7a and 7c and analog telephone sets 22a, 22b, and 22c, and instances of such a network may consist solely of instances of outlet 75 (Fig. 7b), supporting only analog telephony over the network, may consist solely of instances of outlet 70 (Fig. 7a), supporting both telephony and data networking, or a mixed configuration as shown in Fig. 8.

Network 80 offers the advantages of the VoIP technology, yet allows the use of common analog telephones, in the normal way of connecting an ordinary telephone, simply by plugging the telephone's standard connector into the jack 72 within the outlet.

Although outlets 70 and 75 so far have been described as having a single analog telephone connection, it is understood that multiple analog telephone jacks 72 can be supported, wherein separate adapters 21 are used to interface to each telephone jack within the outlets. Similarly, multiple data networking interfaces 73 can be supported in each outlet 70, each connected to different port of hub 31 as shown in Fig. 7a.

Powering outlets 70 and 75, as well as the analog telephones (via adapter 21) can be implemented either locally by connecting a power supply to each outlet, or, preferably, via the network itself. In the latter case, commonly known

as "Power over LAN", the power can be carried to the outlet from a central location either by an additional wire pair, using the well-known phantom configuration, or by the FDM (Frequency Division / Domain Multiplexing) method. The latter commonly employs DC feeding, which is frequency-isolated
5 from the data carried in the higher part of the spectrum.

In another embodiment, the invention is used in a data network over in-building telephone lines, where the analog telephony signals are carried in the low-frequency portion of the spectrum, and the data communication signals are carried in the high-frequency portion. Fig. 9 shows an outlet 90 according the
10 present invention, which is able to separate and combine signals in different portions of the spectrum. Outlet 90 connects to the telephone wiring via a connector 91, preferably located at the rear part of outlet 90, where outlet 90 mechanically mounts to an interior wall of the building. A Low Pass Filter (LPF) 37 in outlet 90 is used for isolating the analog telephony part of the spectrum, for
15 connecting an analog telephone via a jack 92. Jack 92 is preferably a standard telephone jack, such as RJ-11 in North-America. Data communication signals are isolated by a High Pass Filter (HPF) 38, which connects to a Data Communications Equipment (DCE) unit 39, containing a modem for data communications over the telephone line media. An integrated hub 41 allows
20 sharing data between VoIP adapter 21 and a data jack 93, for connecting external devices to the network via DEC unit 39 with a standard data networking interface (such as a 10BaseT interface per IEEE802.3). The adapter 21 allows connection of an analog telephone set to a jack 94, similar to jack 92, as previously described, thereby allowing digitized / packetized analog voice signals used by
25 an analog telephone connected to the jack 94 to be multiplexed on data signals received by the data jack 93. Jack 94 is preferably a standard telephone jack, such as RJ-11 in North-America. Outlet 90 supports both standard analog telephony (via jack 92) as well as VoIP telephony using a standard analog telephone, via jack 94.

Thus, outlet 90 supports three types of interface: Regular analog telephony (via jack 92), data communications (via jack 93), and VoIP telephony (via jack 94). A subset of such functionalities can also be provided. For example, an outlet solely supporting VoIP telephony can be implemented, eliminating the need for LPF 37 and jack 92, as well as eliminating hub 41 and jack 93. In such a case, adapter 21 directly connects to DCE unit 39.

Fig. 10 illustrates a network 100 that operates over telephone lines 5a, 5b, 5c, 5d, and 5e according to the present invention. Network 100 employs outlets 90a, 90d, 95b and 96c. Outlet 95b differs from outlet 90a and outlet 90d by not having PSTN support, because no low-pass filter (LPF) and associated jack are present in outlet 95b as in outlet 90a and outlet 90d. Similarly, outlet 96c allows only for PSTN connection by employing LPF 37b and an analog telephone connector jack. Any mixture of such outlets (90a, 90d, 95b and 96c) is possible.

Network 100 of Fig. 10 supports regular PSTN telephony service via analog telephone sets 22a, 22b, and 22c. Simultaneously, VoIP telephony services can be accessed by analog telephone sets 22d, 22e, and 22f. In addition, data networking can be accomplished by data units 7a, 7b and 7c.

Although outlets 90a and 90d are each described above as having a single PSTN/POTS telephone connection, it is understood that multiple PSTN/POTS telephone interfaces can be supported within a single outlet. Similarly, it is understood that multiple VoIP/POTS telephone interfaces can be supported via multiple adapters (such as adapter 21a) within an outlet. Similarly, multiple data network interfaces can be included within an outlet, each connected to different port of the respective hub (such as hub 41a).

Life-line

The term "life-line" refers to the concept of the telephone as a basic and emergency service, whose functionality must be maintained. As such, it is required that malfunctions in any other system or service (e.g. electricity) will not degrade the telephone system capability. In practical terms, this means that as

long as an operative telephone set is actively connected to the telephone exchange via uninterrupted two-wires, the telephone service will be maintained, even in the case of a failure of electrical power.

A major drawback of using VoIP technology according to hitherto-
5 proposed schemes is that life-line capability is not supported, and any failure of the data network (e.g. power outage, or hub, DCE, or software failure) will result in loss of the IP-telephony based service. The absence of "life-line" capability with regard to analog telephone 22d may be seen in Fig. 10. Thus, analog telephone 22d is connected via the data network through adapter 21a, hub 41a,
10 and DCE unit 39a, and thus a power failure or failure of any one of these active devices will cause a loss of service via analog telephone 22d. Hence analog telephone 22d does not have "life-line" capability. The same is true of analog telephones 22e and 22f.

In contrast, however, analog telephone 22a is connected to telephone line
15 5a / 5b through a low-pass filter 37a. LPF 37a is a passive device of relatively high reliability and immunity to failure. Thus, analog telephone 22a retains life-line capability as part of the PSTN network. This also holds for analog telephone 22c. Thus, network 100 has partial life-line capability.

Fig. 11 illustrates an outlet 110 according to the present invention for
20 insuring universal life-line capability. Outlet employs a relay 112 which operates in a 'fall-away' mode, as is well-known in the art. Relay 112 is the principal component added to those components in outlet 90a to provide a telephone connection which for the most part is based on packet telephony, but which also provides life-line capability. Outlet 110 has several jacks. A jack 93 connects
25 directly to a hub 41 to provide a full-time data connection. A jack 92 connects directly to a low-pass filter 37 to provide a full-time analog telephony connection. A jack 117 connects to a pole 112a of relay 112. A throw 112b of relay 112 is connected to adapter 21, which provides conversion between VoIP packet telephony and analog telephony. A throw 112c, however, is connected to

LPF 37. In non-energized state, pole 112a connects to pole 112c. A Sensor 111 controls the state of relay 112, depending on the availability of data communications on the network. Inputs 113, 114, 115, and 116 to sensor 111 come from adapter 21, hub 41, DCE unit 39, and the input to high-pass filter 38, respectively and thus sensor 111 is able to detect any failure of the local or network data path, such as no network activity, loss of network power, or any other fault condition. In normal operation, when network data communications are functioning, relay 112 is triggered to connect jack 117 to adapter 21, and thus jack 117 normally connects an analog telephone to a packet telephony network via a VoIP / analog adapter. In the event of any failure of network data communications or power outage, sensor 111 releases relay 112 to switch jack 117 to LPF 37, and thus an analog telephone connected to jack 117 remains active even if the data network is inoperative, provided that the analog telephone service is available. Outlet 110 thus has life-line capability while normally supporting packet telephony. Under these circumstances, jack 92 may not be necessary and can be eliminated. It will be understood that while in the preceding description, a mechanical relay is used for the above switching functionality, any switching mechanism can be equally employed. Thus, within the context of the description and the appended claims, the term "relay" encompasses any electro-mechanical and electronic switches adapted to connect a common connection to either of two possible connections in response to an external trigger.

Fig. 12 illustrates another embodiment of an outlet according to the present invention for providing life-line capability. Whereas outlet 110 (Fig. 11) has been described with reference to a telephone line data networking environment, which has analog telephony inherently available, Fig. 12 illustrates an outlet 120 which can be applied to any LAN. Relay 112 and sensor 111 perform the same functions as previously described for outlet 110. However, analog telephone signals are not commonly available in network environments used strictly for data, and are therefore provided to outlet 120 via a connector 122

by dedicated wiring, preferably carried along with the network wiring structure. A line 121 carries the signals from connector 122 to a throw of relay 112. Alternatively, the analog telephony signals may be carried on the network wiring, such as by using FDM. Fig. 13 illustrates an outlet 130 for use in such a case,
5 where a POTS isolation unit 131 feeds the analog signal via line 121 to relay 112.

Fig. 14 illustrates the main application of the present invention. A network 140 includes part or all of network 100, which exists within a building. Network 140 connects to an IP network 142, operated by a service provider or 'IP-carrier',
10 and which carries both data and voice (using the VoIP technique). A gateway 141 is used for bridging the in-building network to IP network 142, and is connected to existing in-home telephone wiring 5a, 5b, and 5c. This configuration allows the IP-carrier to provide both data and voice services, eliminating the need to modify or add in-building wiring, and requiring only
15 replacement of the telephone outlets.

Although the invention has been so far demonstrated as relating to telephone wiring and telephone outlets, the invention can be similarly applied to any type of wired networking within a building, such as CATV or electrical power wiring. Fig. 15 illustrates an outlet 150, which is a general embodiment of
20 the present invention. Outlet 150 is similar in overall layout to outlet 90 (Fig. 9). Outlet 150 connects to the relevant wiring via a connector 151 and contains an integrated data/service splitter/combiner unit 152, which isolates the data carried over the wiring from the main service signal. In the case of telephony, unit 152 contains a low-pass filter (such as LPF 37) and a high-pass filter (such as HPF
25 38). In the case of electrical power wiring, the AC power is split by unit 152 and fed to a socket 154, for supplying electrical power as normal. In such a case, a modem 153 being a power-line carrier (PLC) modem interfaces the hub 41 to the integrated data/service splitter/combiner unit 152, and allows data communication over the power line. Similarly, in the case of a CATV application, where

the CATV wiring is used for the network infrastructure, a coaxial cable modem is used as modem 153 and unit 152 isolates the CATV signal from the data signal.

Although the invention has been so far described as relating to IP-based data networks, the invention can be similarly applied to any type of packet data network. Furthermore, although packet networks are the most important for wide area networks, the invention is not restricted to packet networks only, and can be applied to any digital data network, where voice signals are digitized and carried in digital form.

Furthermore, although the invention has been described as relating to networks based on continuous electrical conducting media (telephone, CATV, or electrical power), and the relevant modem and associated circuitry are connected in parallel to the wiring infrastructure, the invention can be applied equally to the case wherein the wiring is not continuous, but is cut into discrete segments as disclosed in WO 00/07322 to the present inventor, which is incorporated by reference for all purposes as if fully set forth herein.

While the invention has been described with respect to a limited number of embodiments, it will be appreciated that many variations, modifications and other applications of the invention may be made.

Claims:

- 1) **An outlet for connecting an analog telephone set to a digital data network carrying voice signals in digital form, the digital network based on wiring in a building, the outlet being adapted for mechanical attachment to, or mounting in, a wall of the building and comprising:
 - a connector for connecting the outlet to the wiring within a bulding;**
 - a telephone jack for connecting an analog telephone set; and**
 - an adapter coupled between the connector and the telephone jack for converting between voice signals in digital form and analog telephone signals,**said outlet further comprising a low-pass filter coupled to a telephone jack for allowing connection of an analog telephone.**

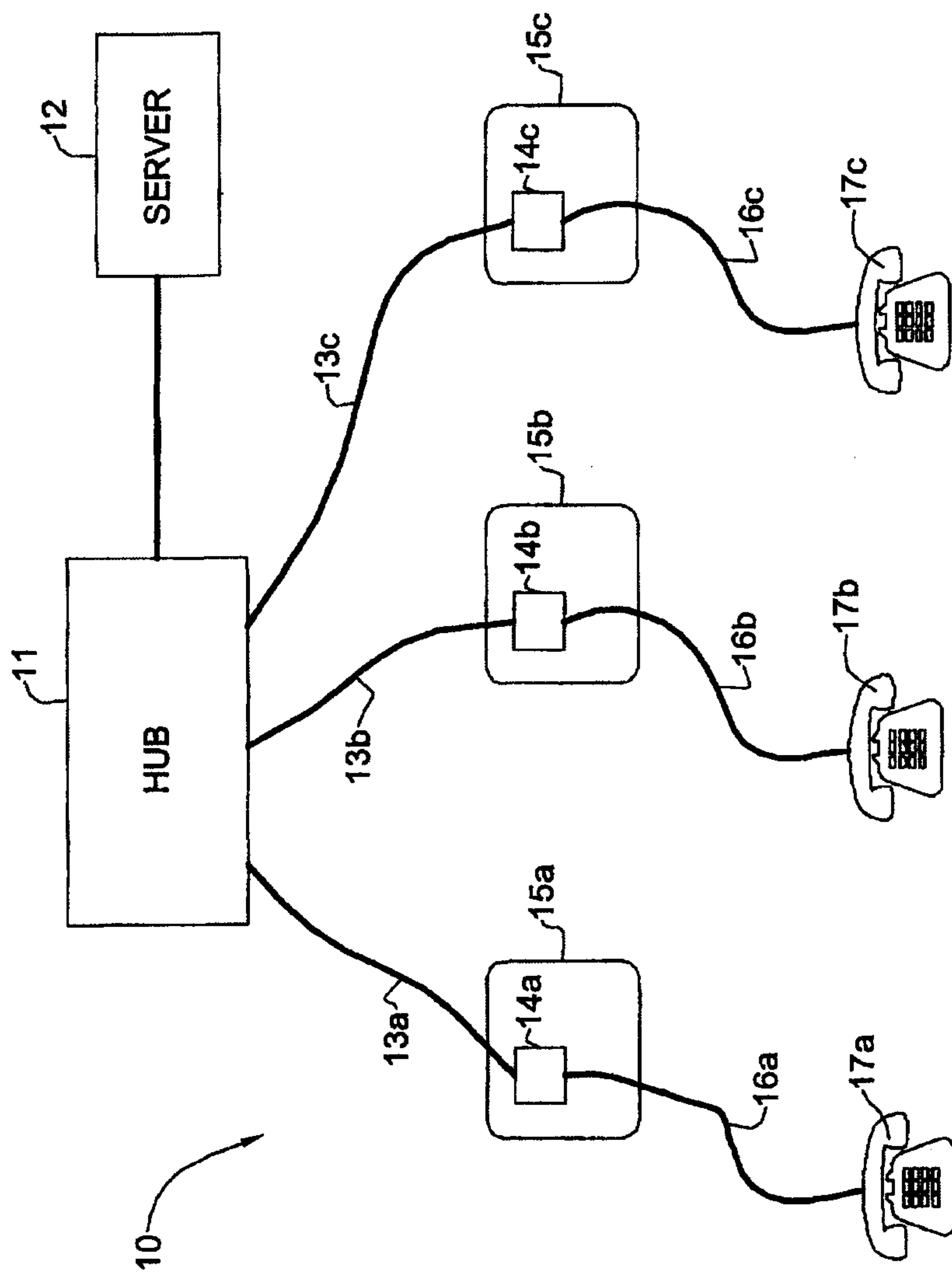

FIG. 1 (PRIOR ART)

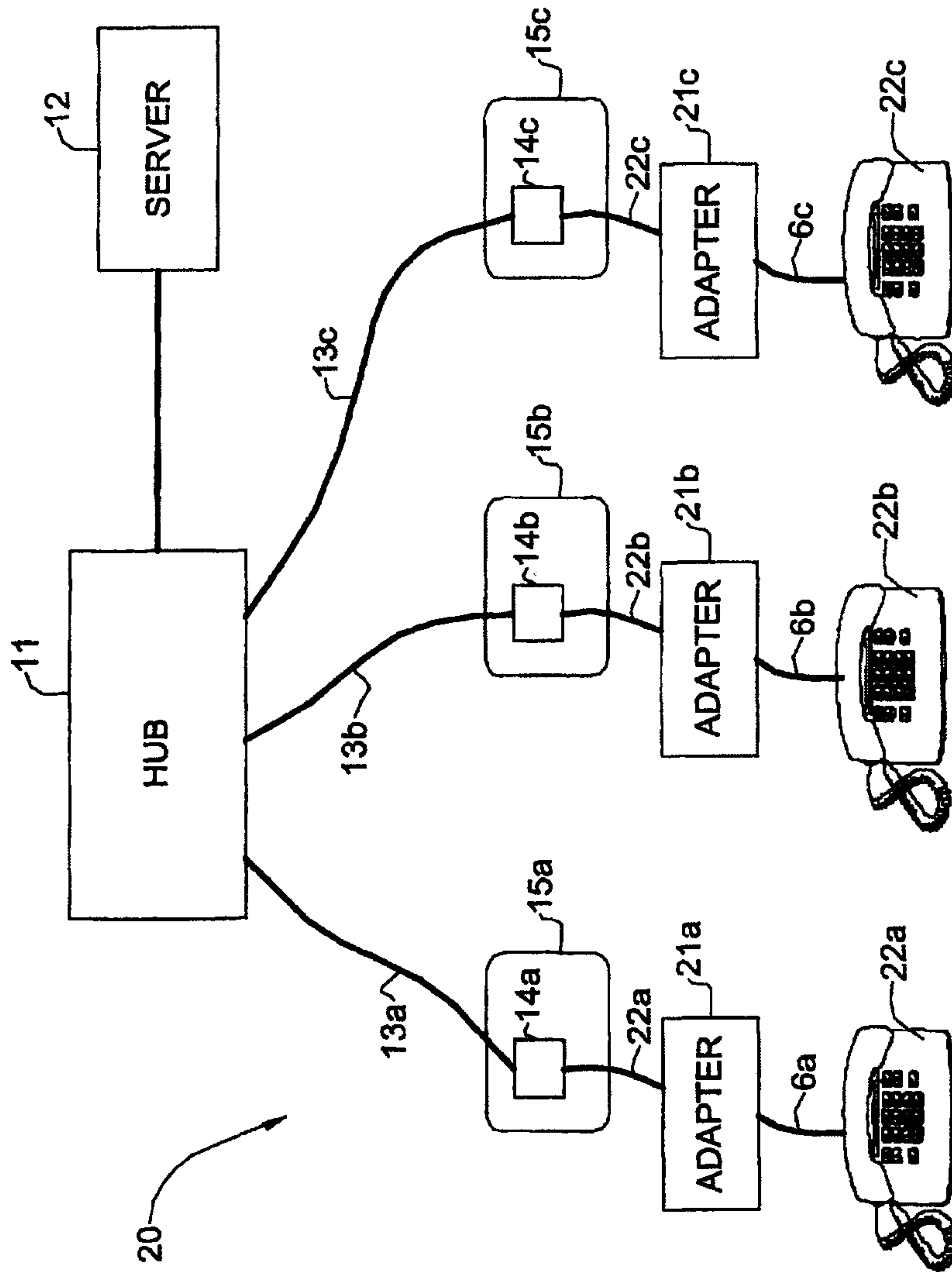

FIG. 2 (PRIOR ART)

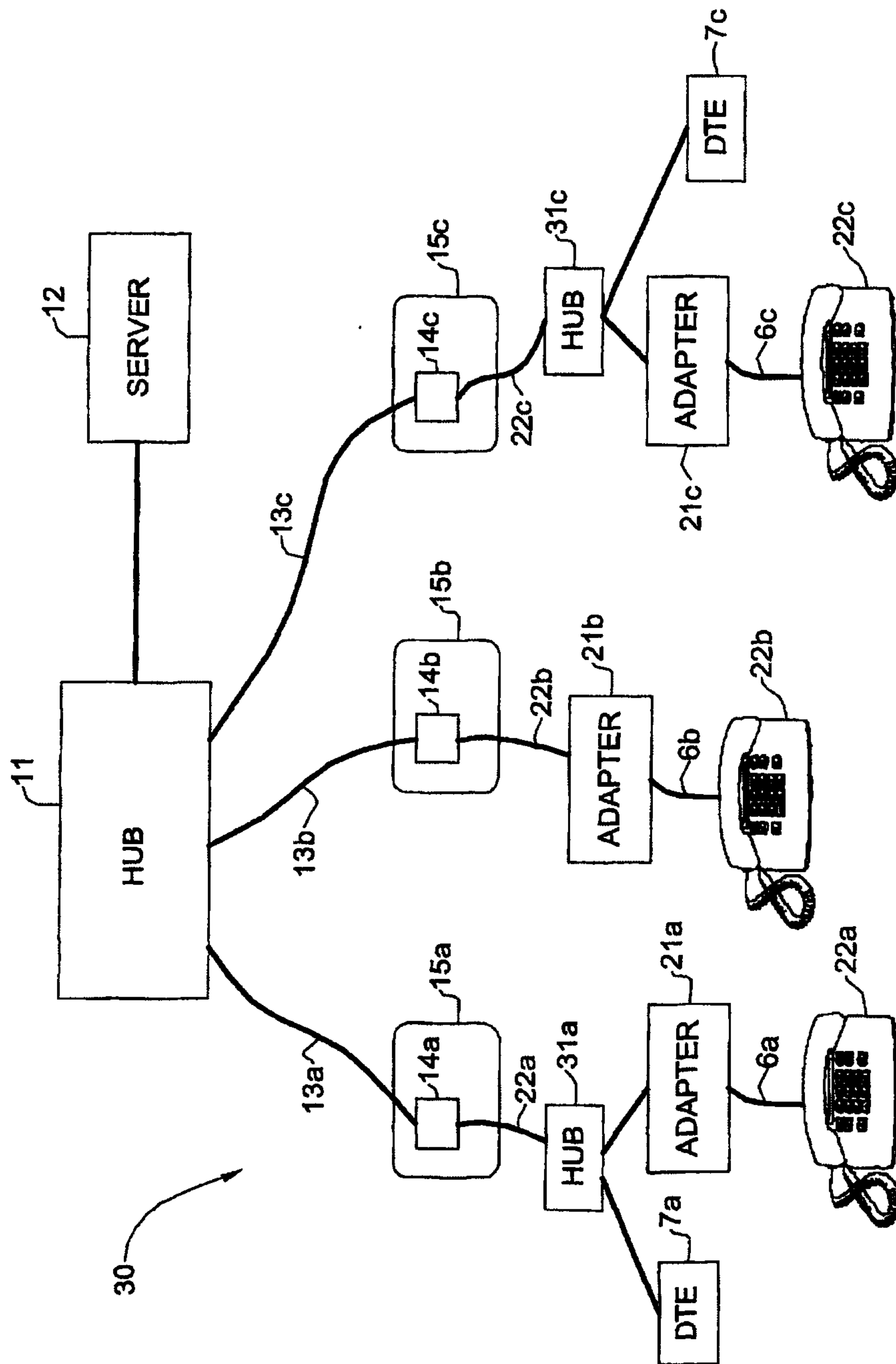

FIG. 3 (PRIOR-ART)

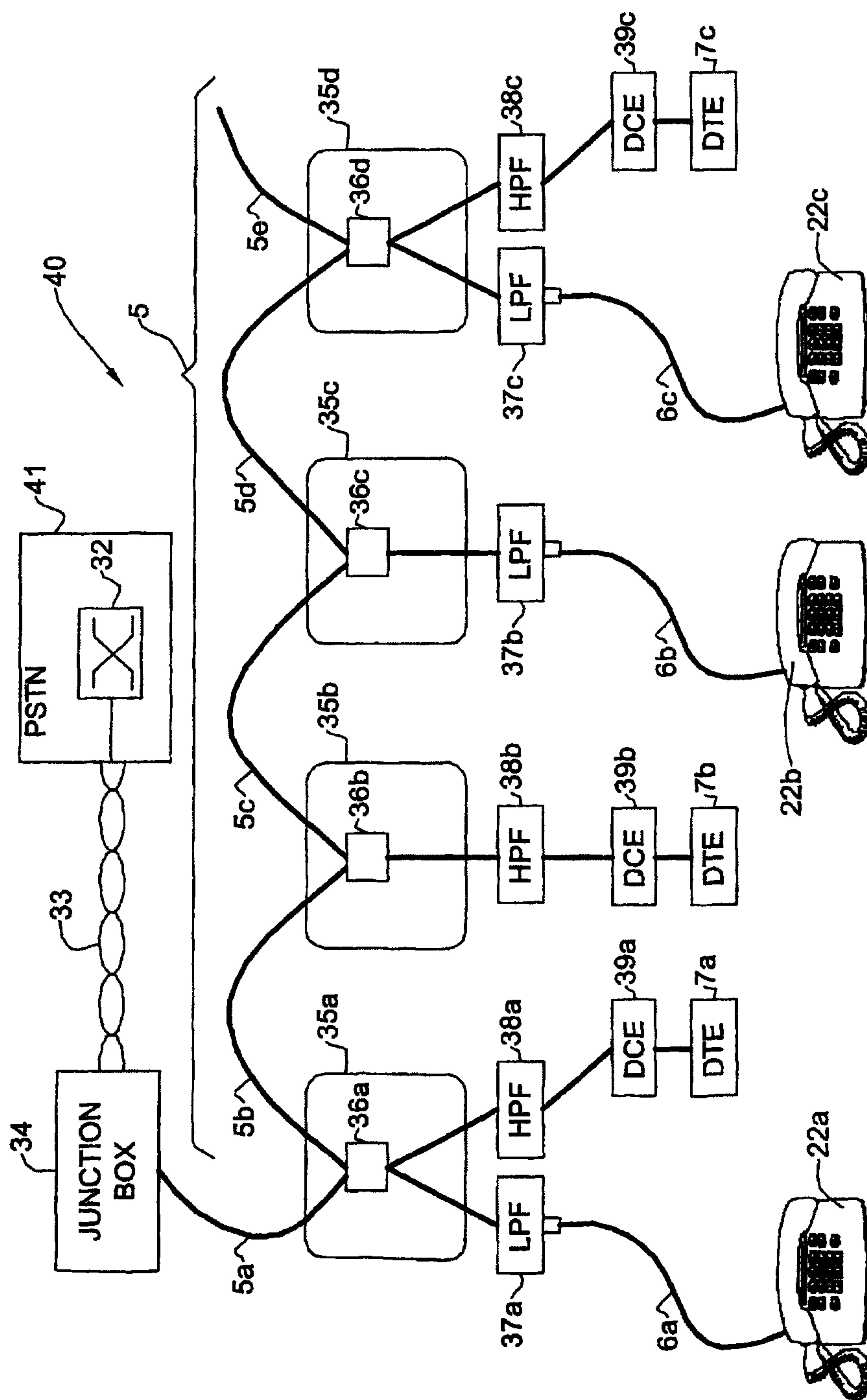

FIG. 4 (PRIOR ART)

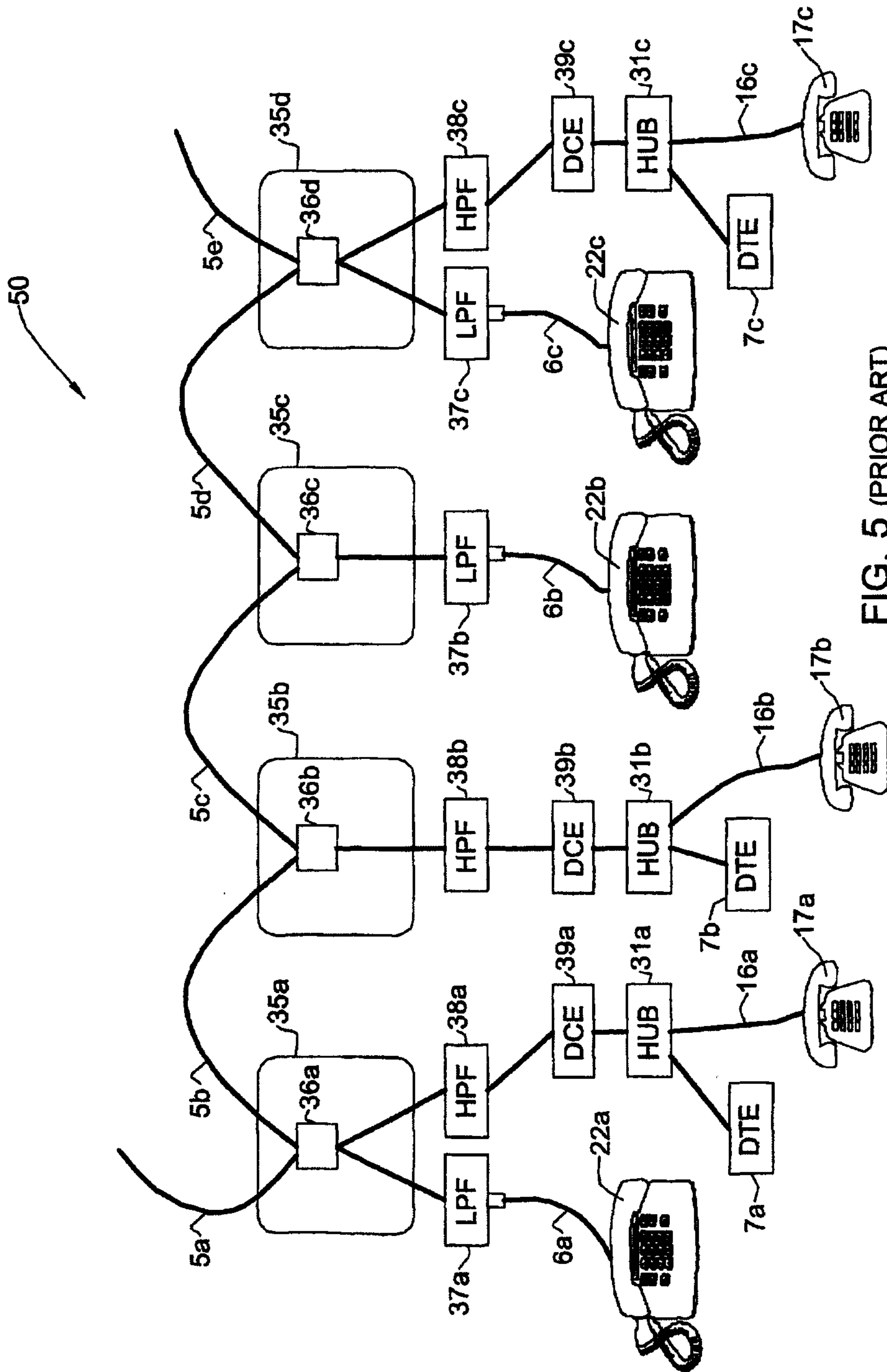

FIG. 5 (PRIOR ART)

6/14

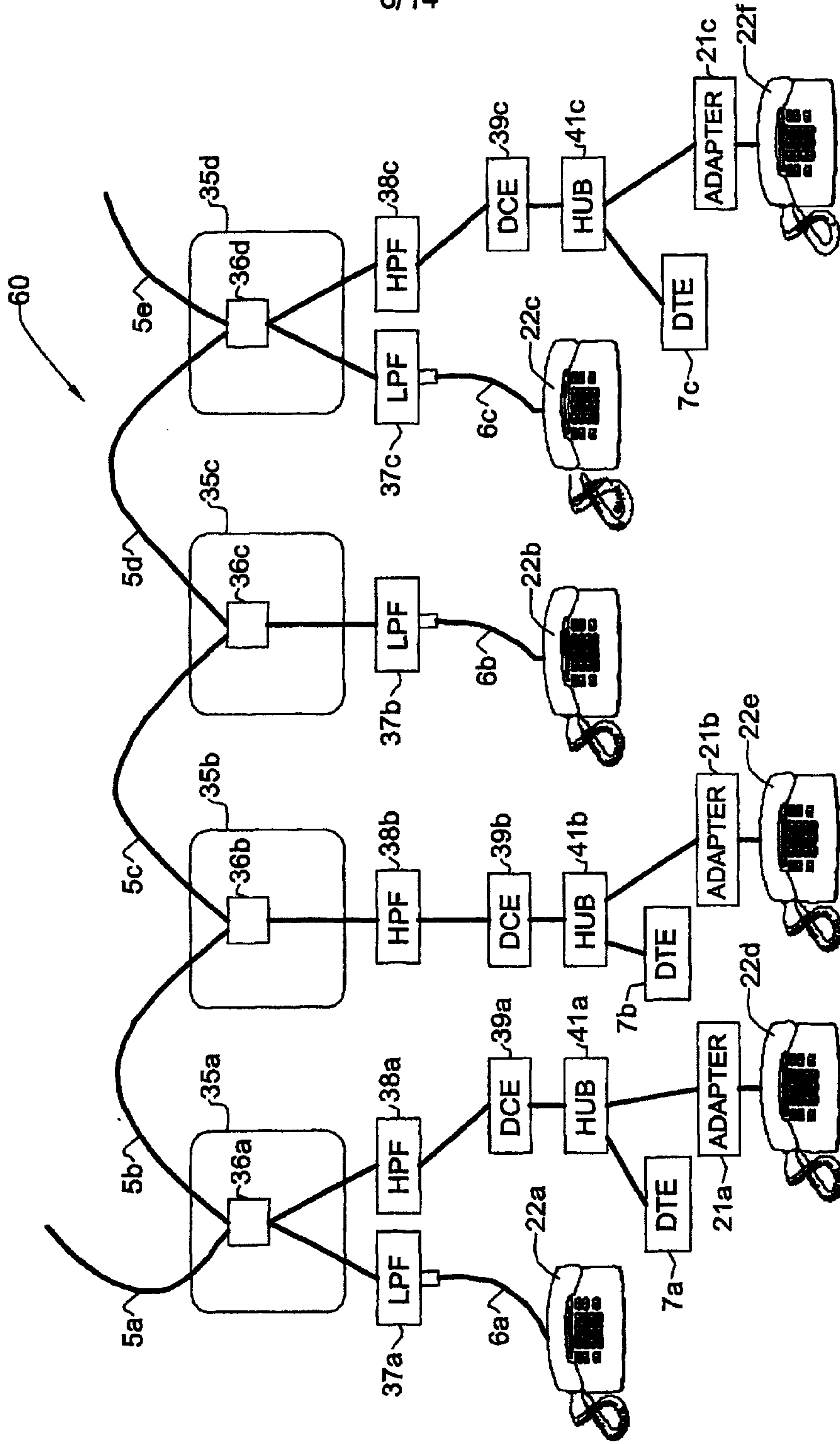

FIG. 6 (PRIOR ART)

7/14

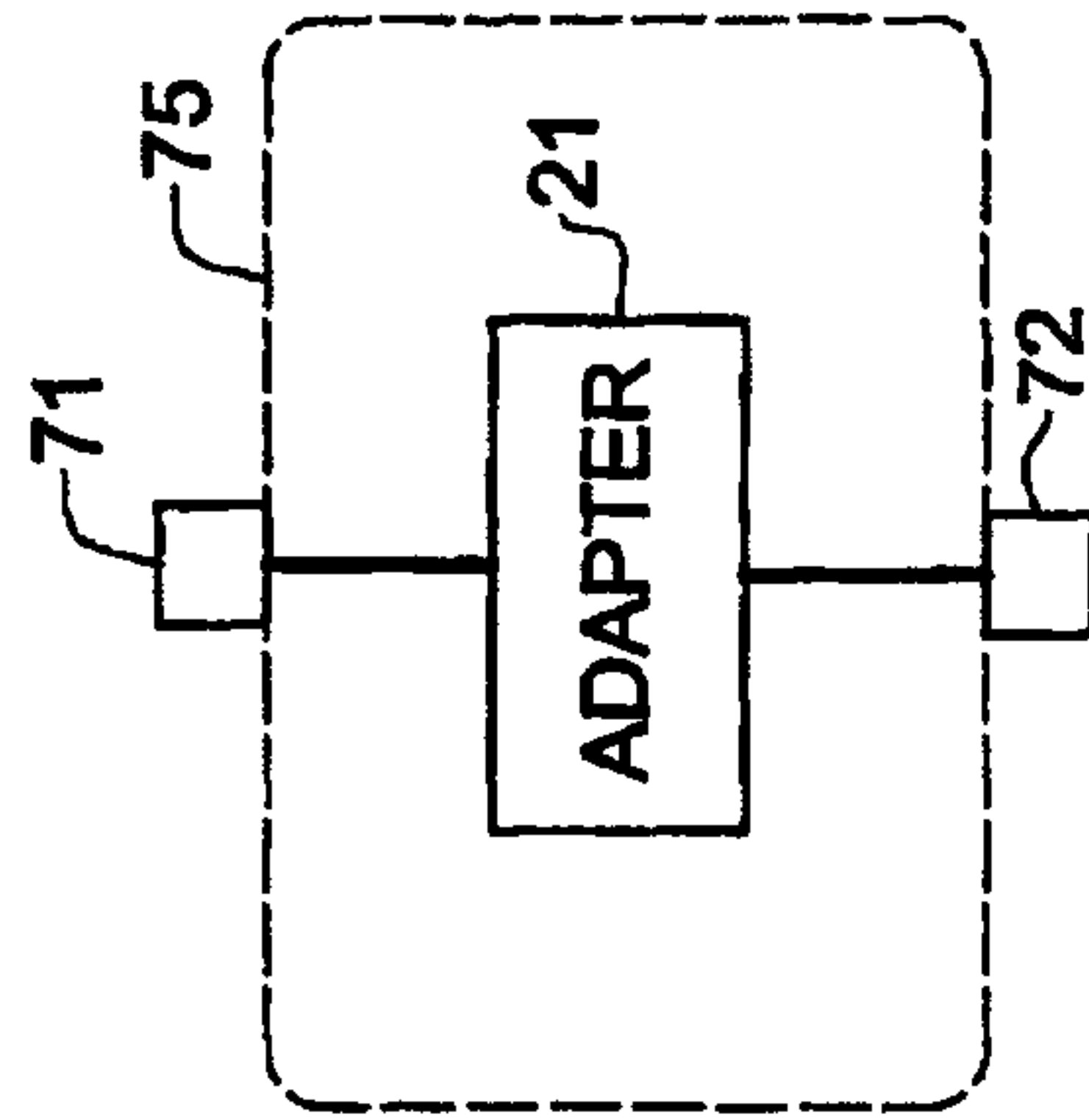

FIG. 7B

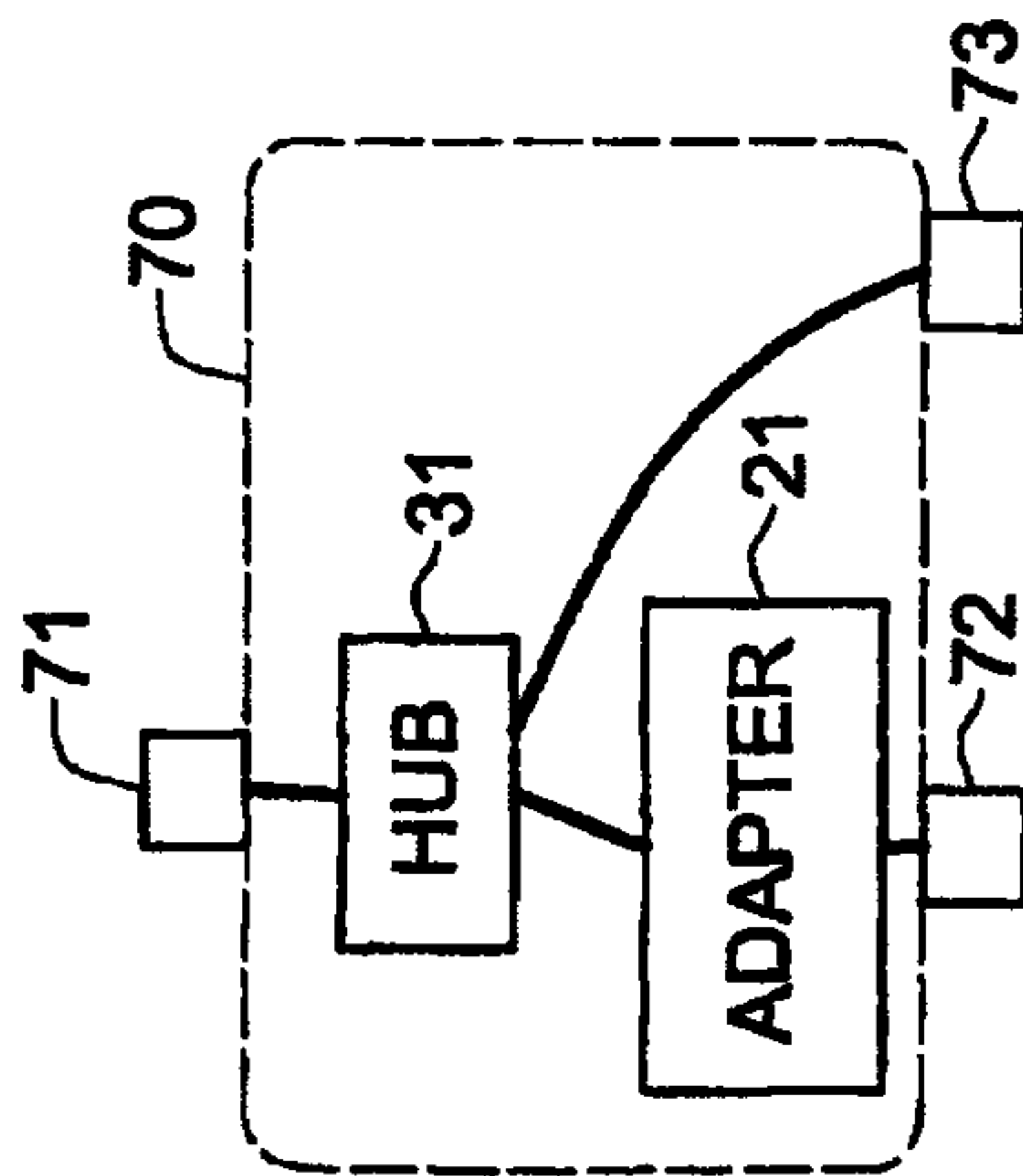

FIG. 7A

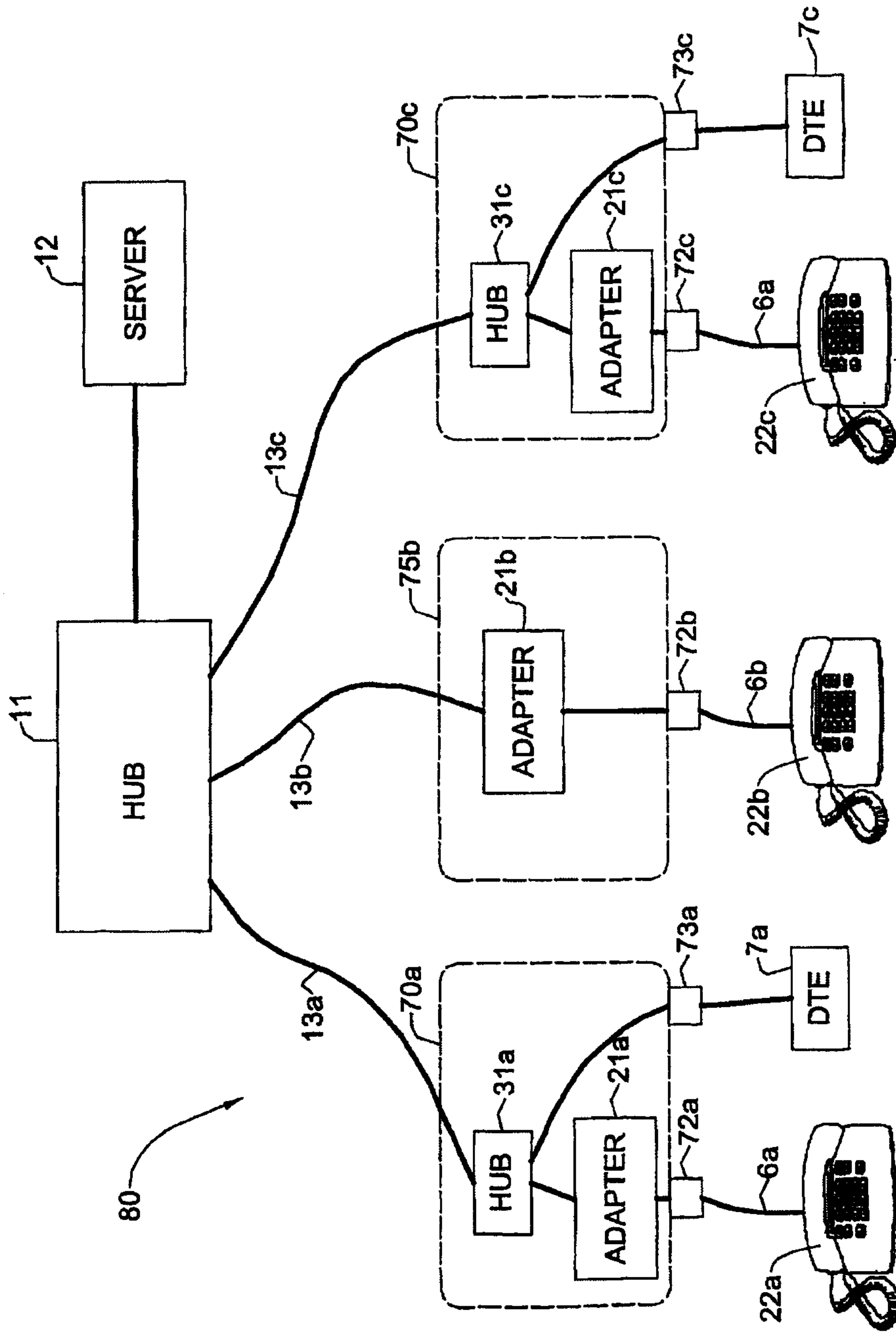

FIG. 8

9/14

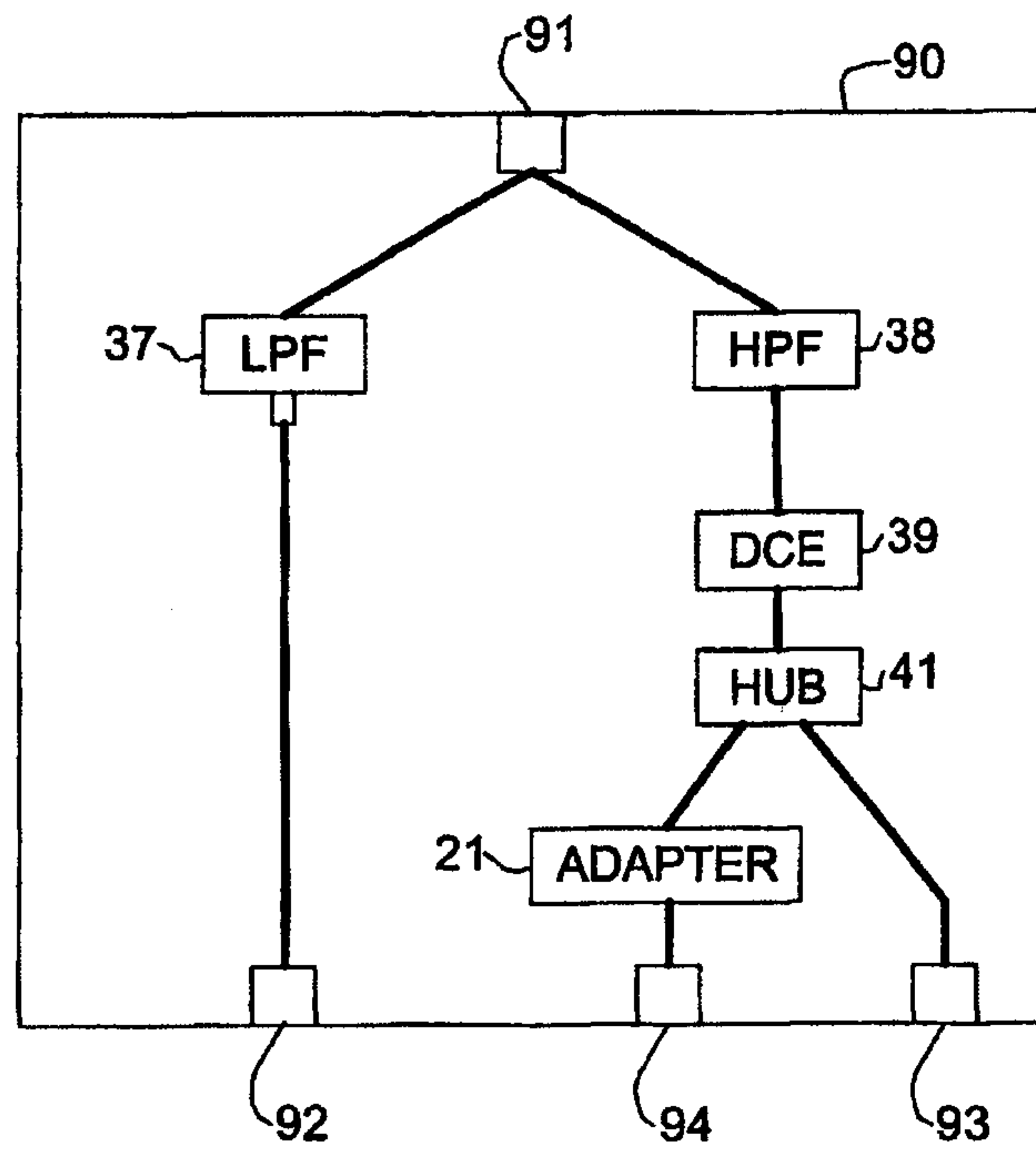

FIG. 9

10/14

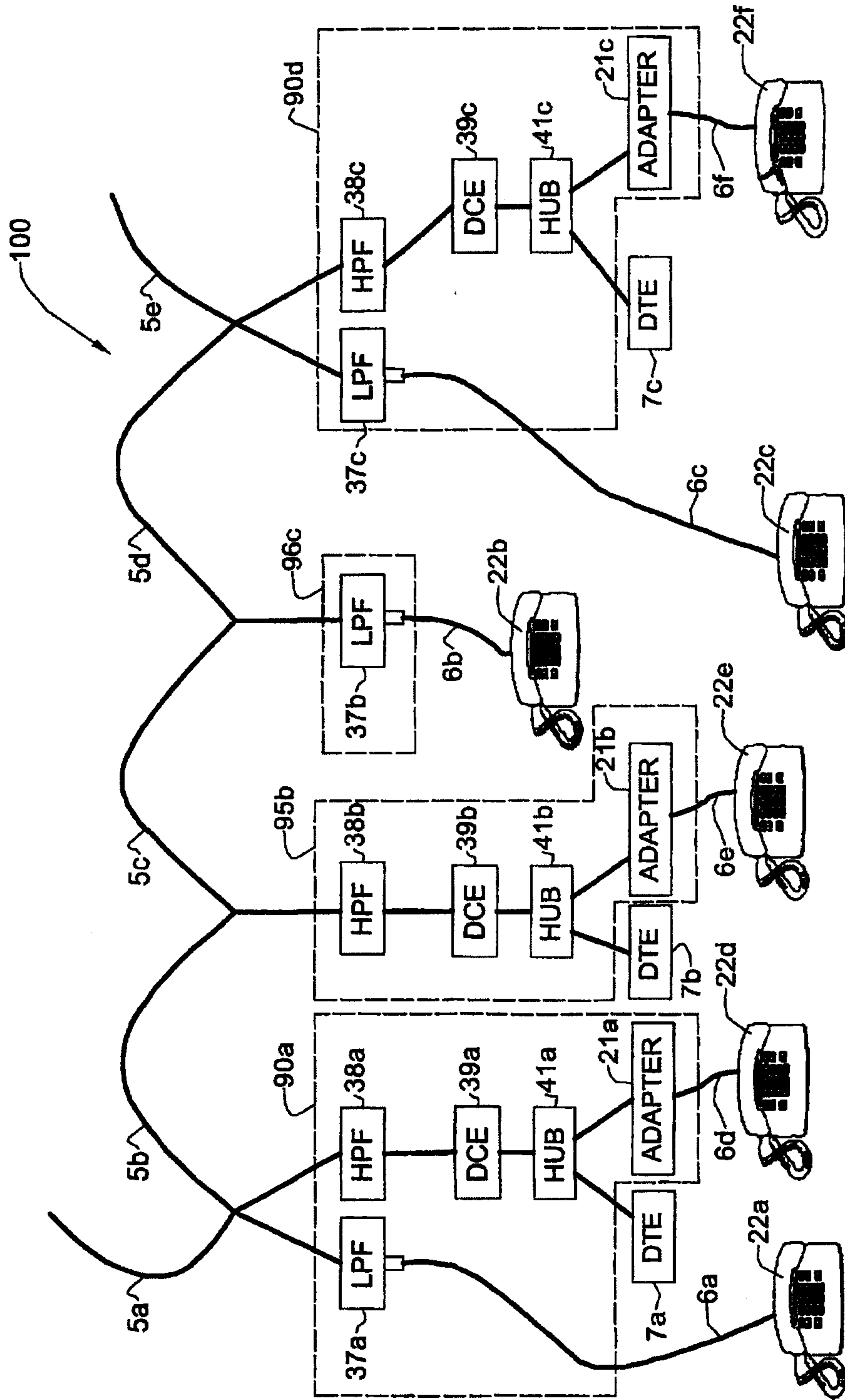

FIG. 10

12/14

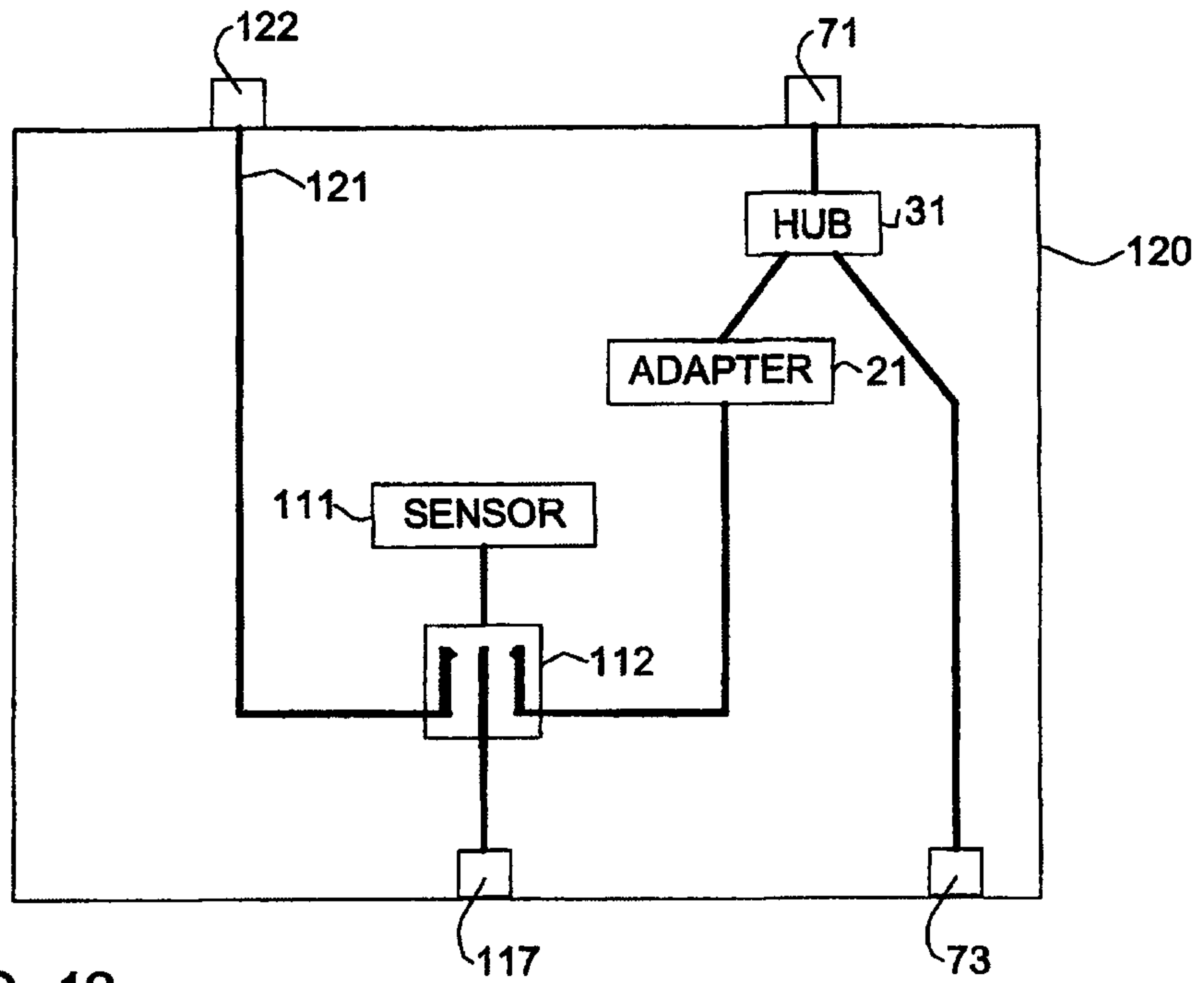

FIG. 12

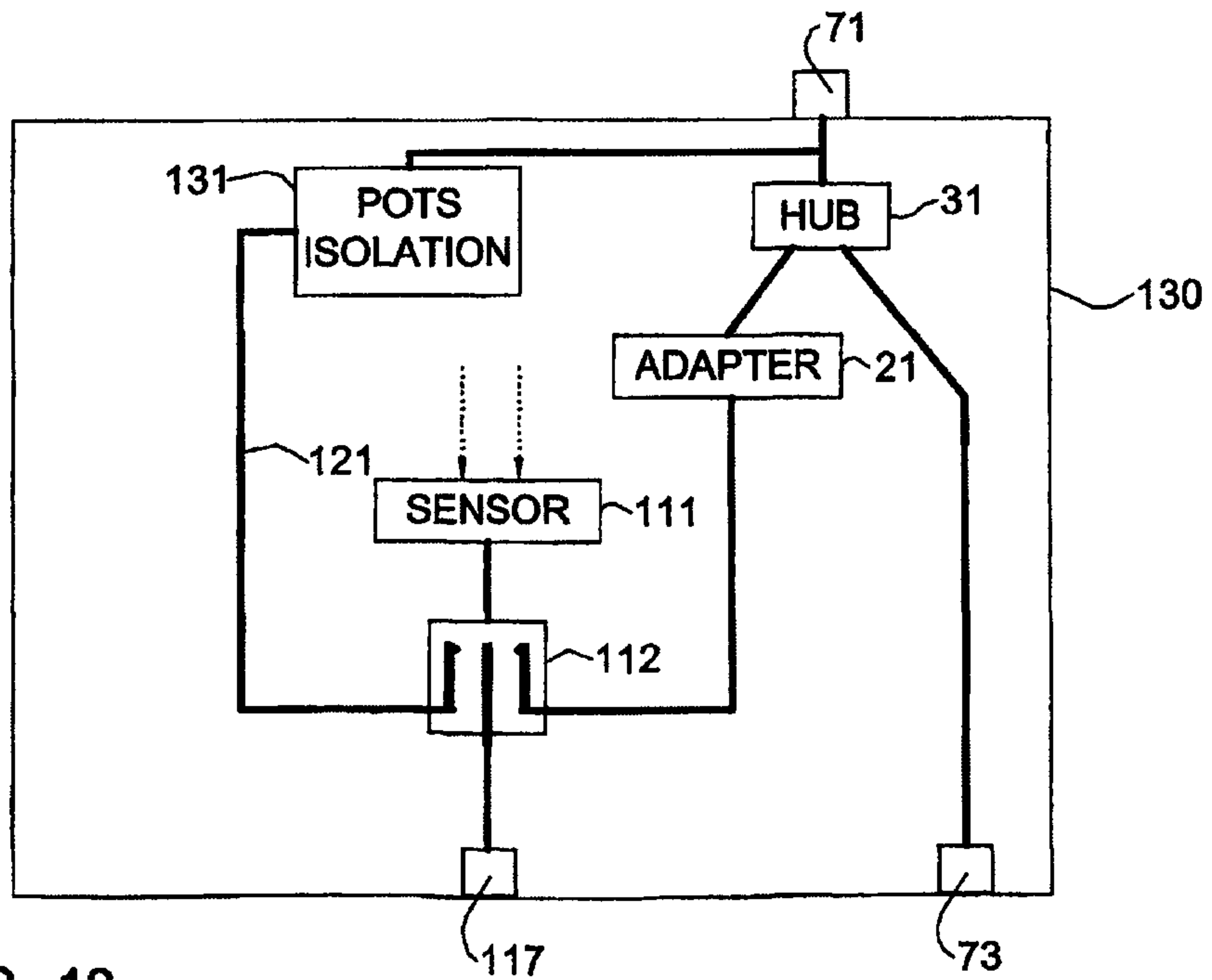

FIG. 13

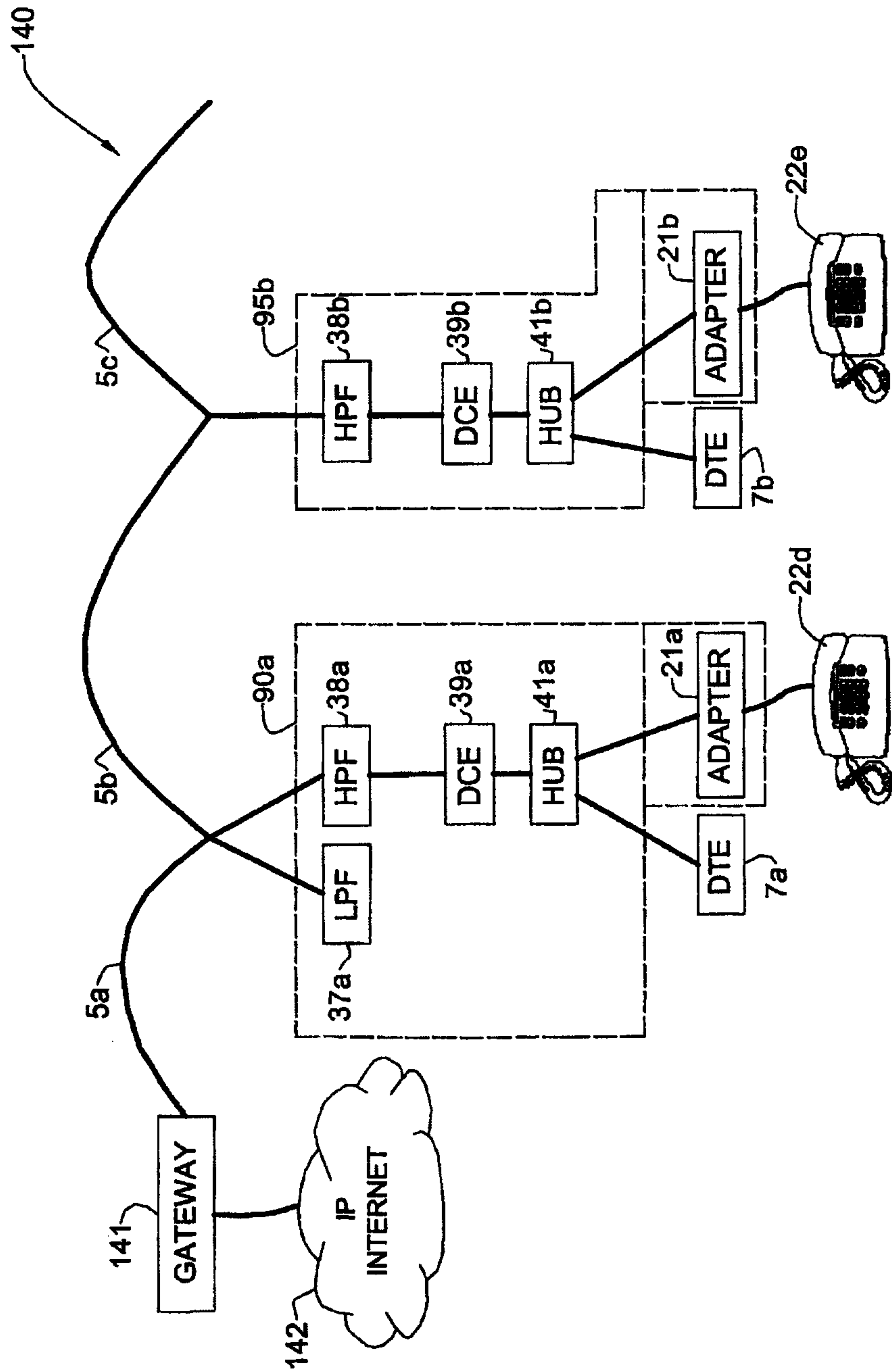

FIG. 14

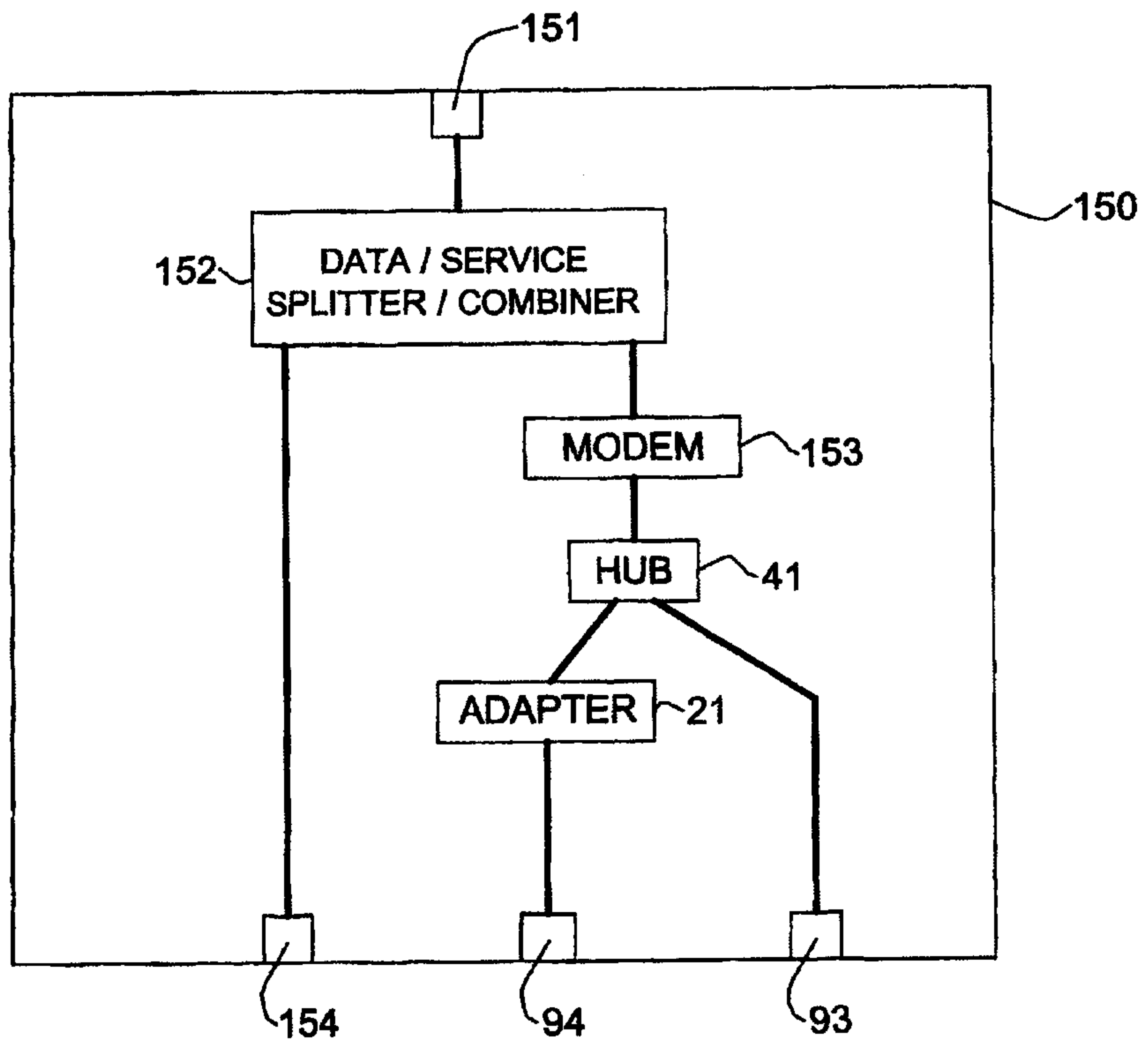

FIG. 15

