



US 20020143402A1

(19) **United States**

(12) **Patent Application Publication**
Steinberg

(10) **Pub. No.: US 2002/0143402 A1**

(43) **Pub. Date: Oct. 3, 2002**

(54) **HIP JOINT PROSTHESES**

(30) **Foreign Application Priority Data**

(75) Inventor: **Amiram Steinberg, Avihail (IL)**

Sep. 4, 1995 (IL)..... 115168

Correspondence Address:

DARBY & DARBY P.C.

805 Third Avenue

New York, NY 10022 (US)

Publication Classification

(51) **Int. Cl.⁷** **A61F 2/32; A61F 2/38; A61F 2/44**

(52) **U.S. Cl.** **623/22.16; 623/22.15; 623/22.12;**
623/23.26; 623/22.28; 623/22.11;
623/20.28; 623/17.12

(73) Assignee: **Limber Ltd.**

(21) Appl. No.: **09/902,701**

(22) Filed: **Sep. 5, 2001**

(57) **ABSTRACT**

Related U.S. Application Data

(63) Continuation of application No. 09/043,076, filed on Feb. 2, 1999, filed as 371 of international application No. PCT/IL96/00098, filed on Sep. 4, 1996.

A joint prosthesis comprising at least a first and a second load carrying member, the first load carrying member being substantially more shock absorbing and resilient than the second load carrying member.

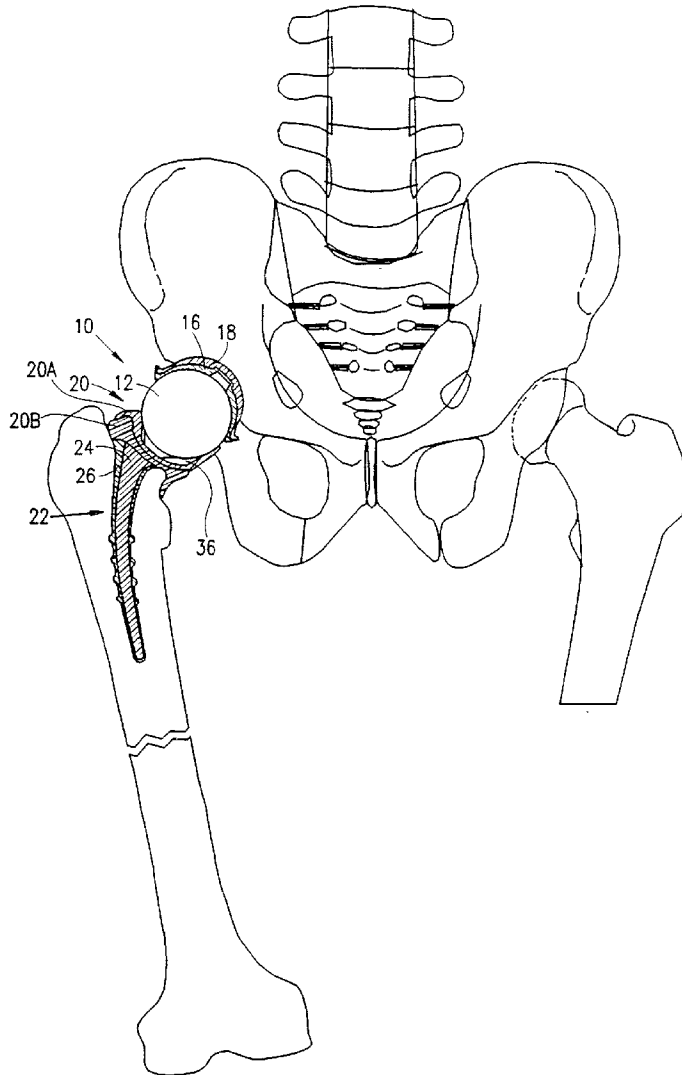
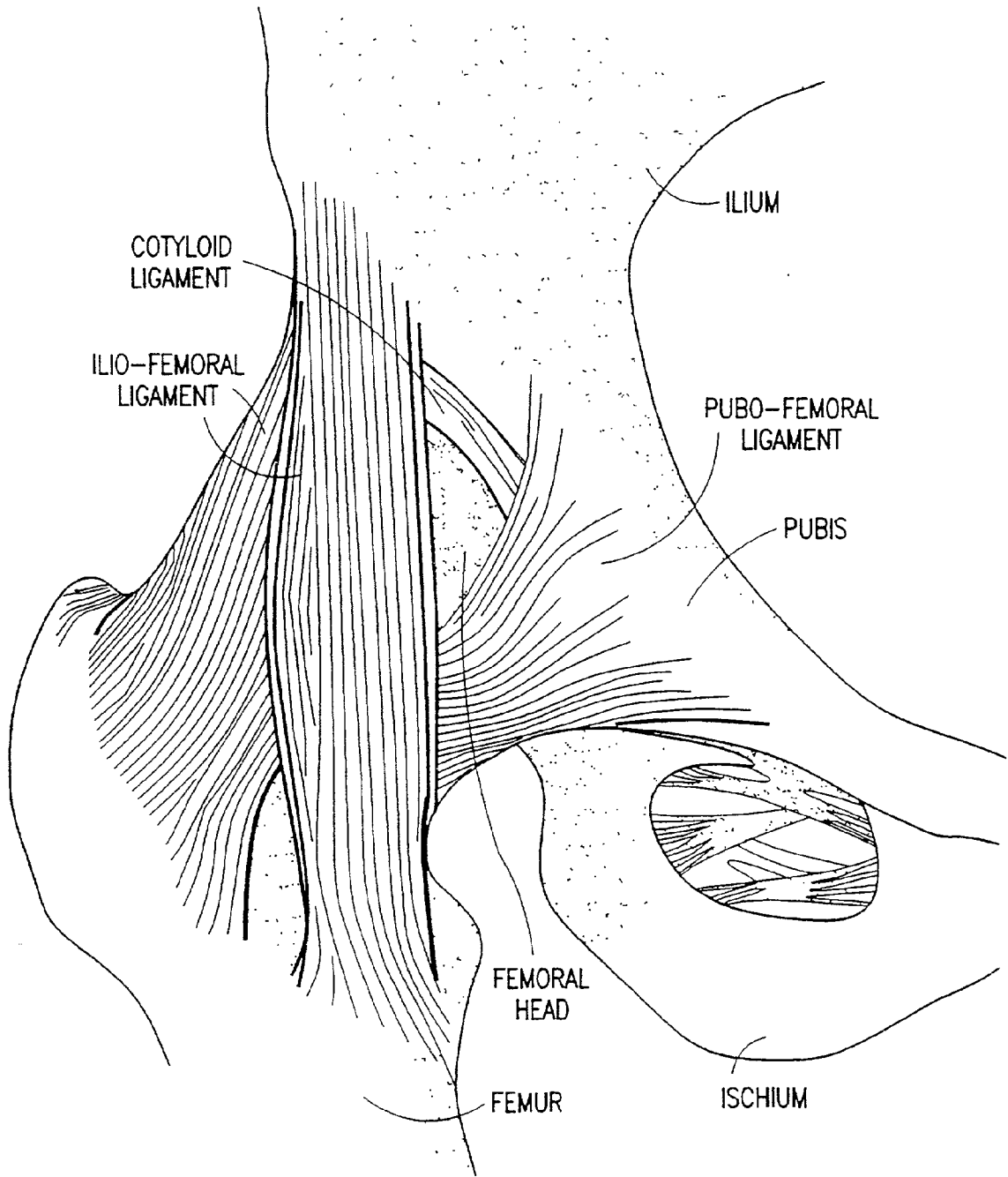

FIG. 1



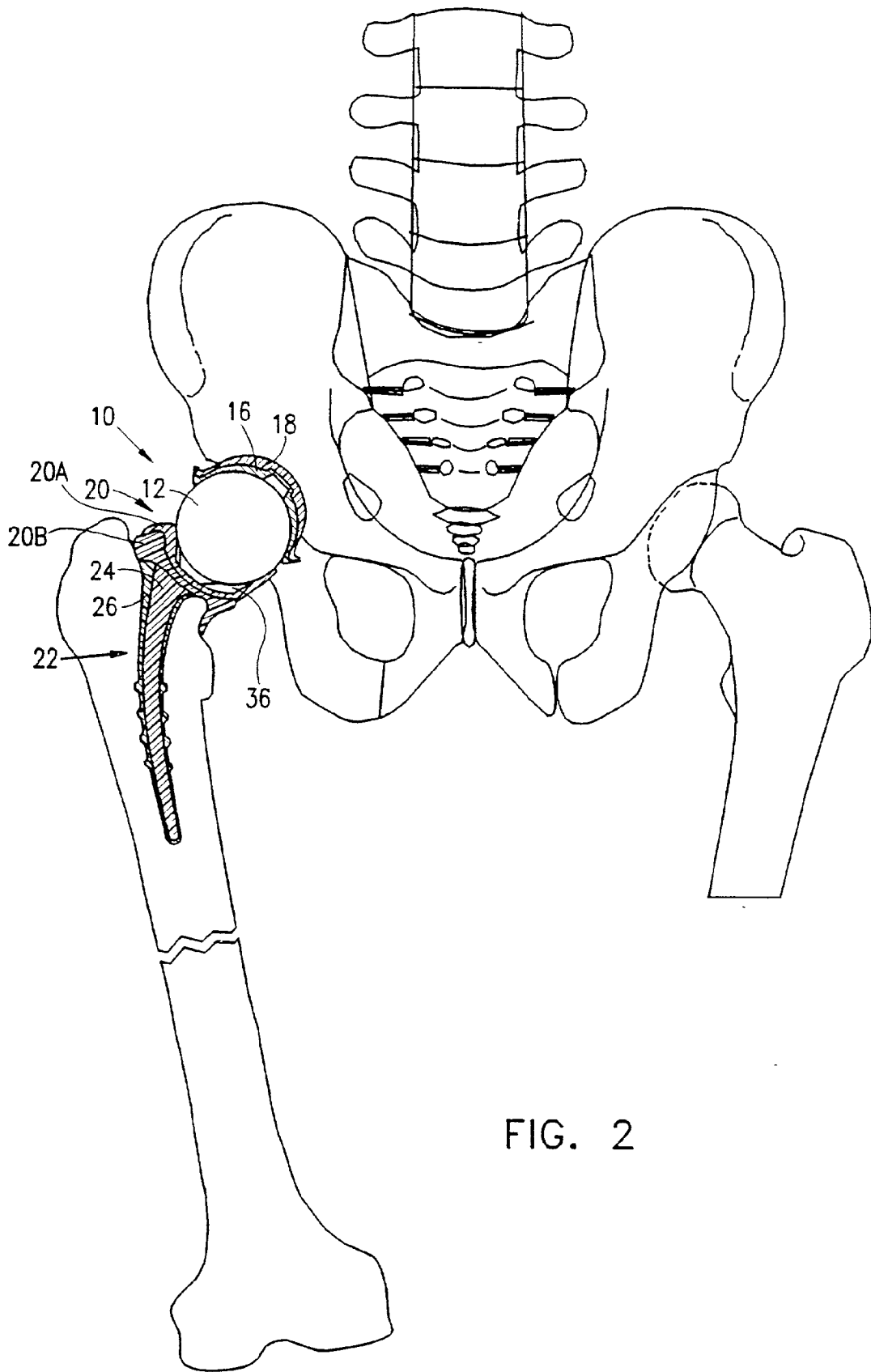

FIG. 2

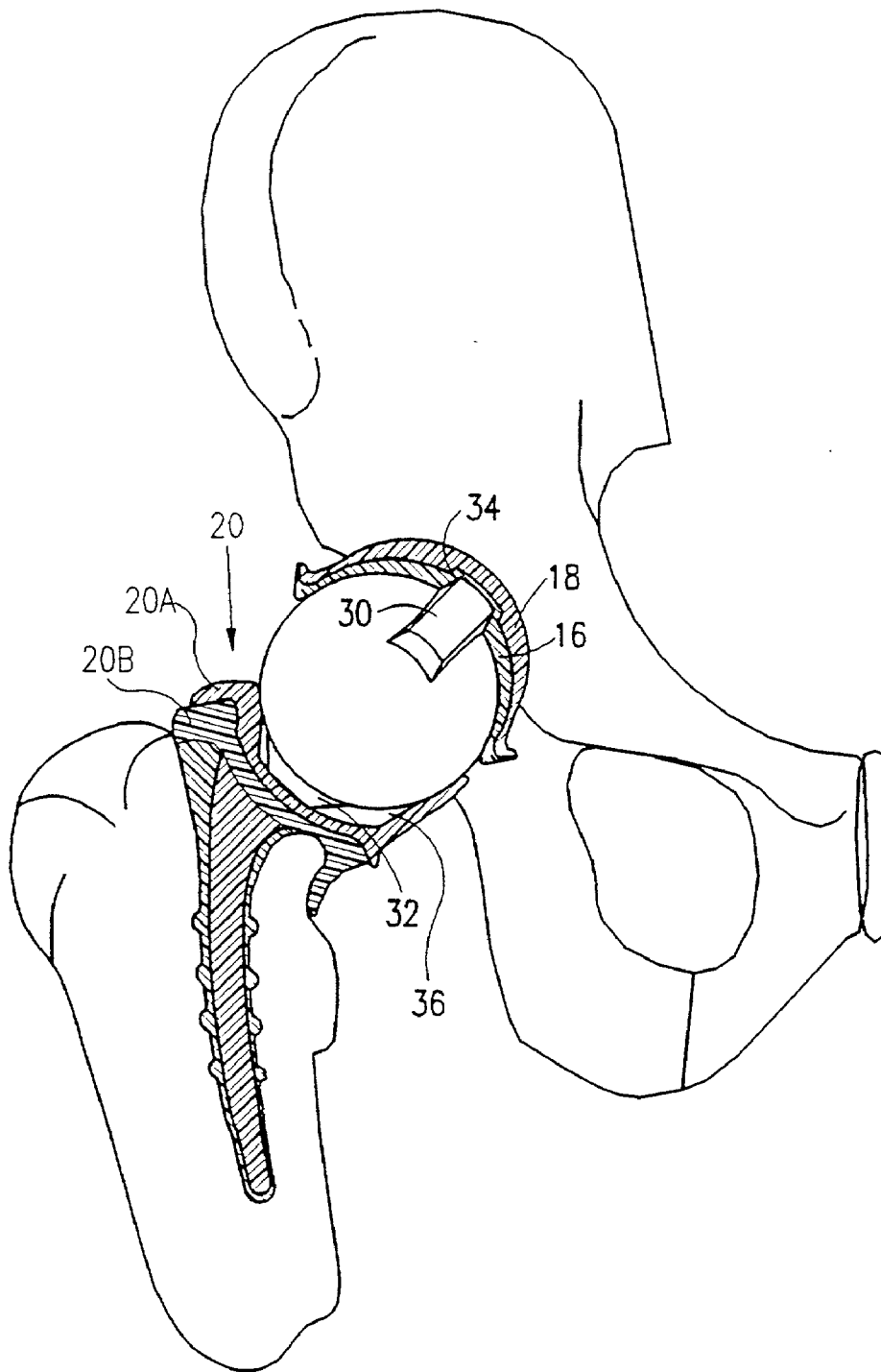

FIG. 5

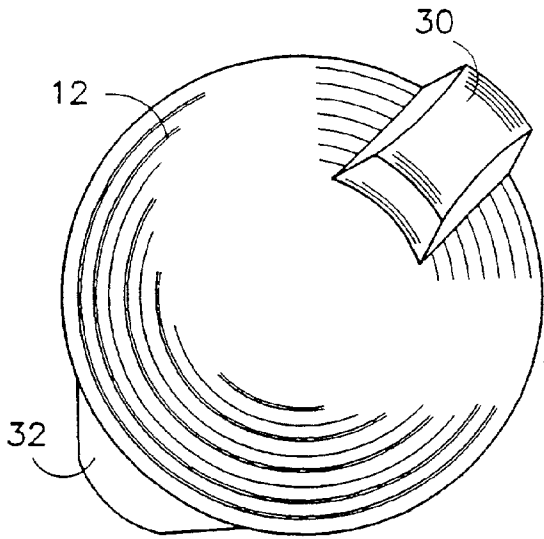

FIG. 6

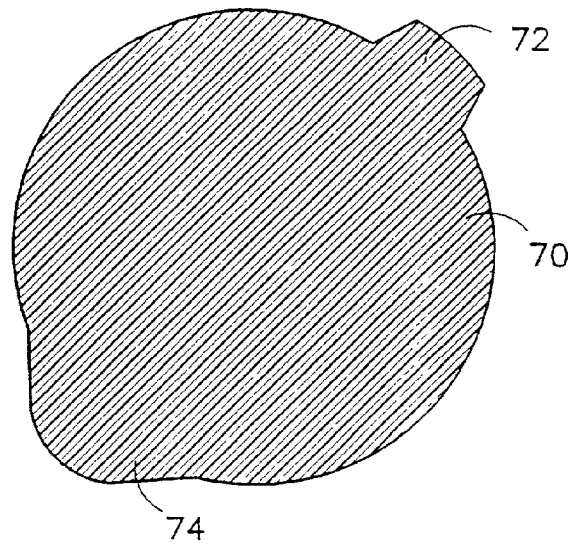

FIG. 10

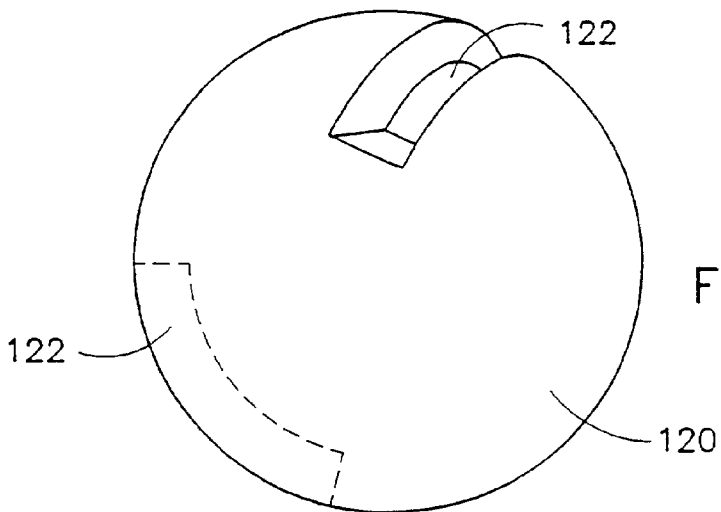

FIG. 15

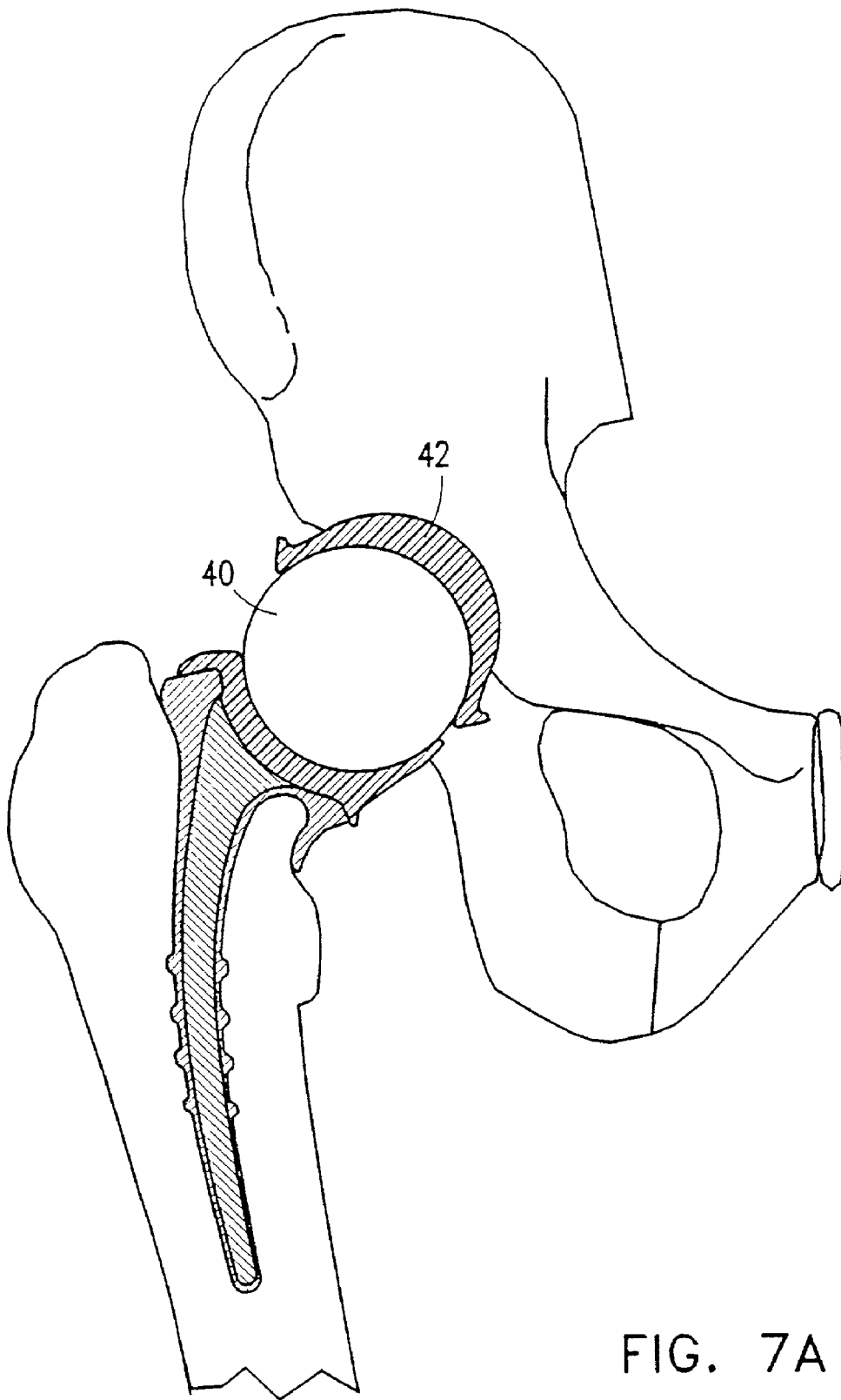

FIG. 7A

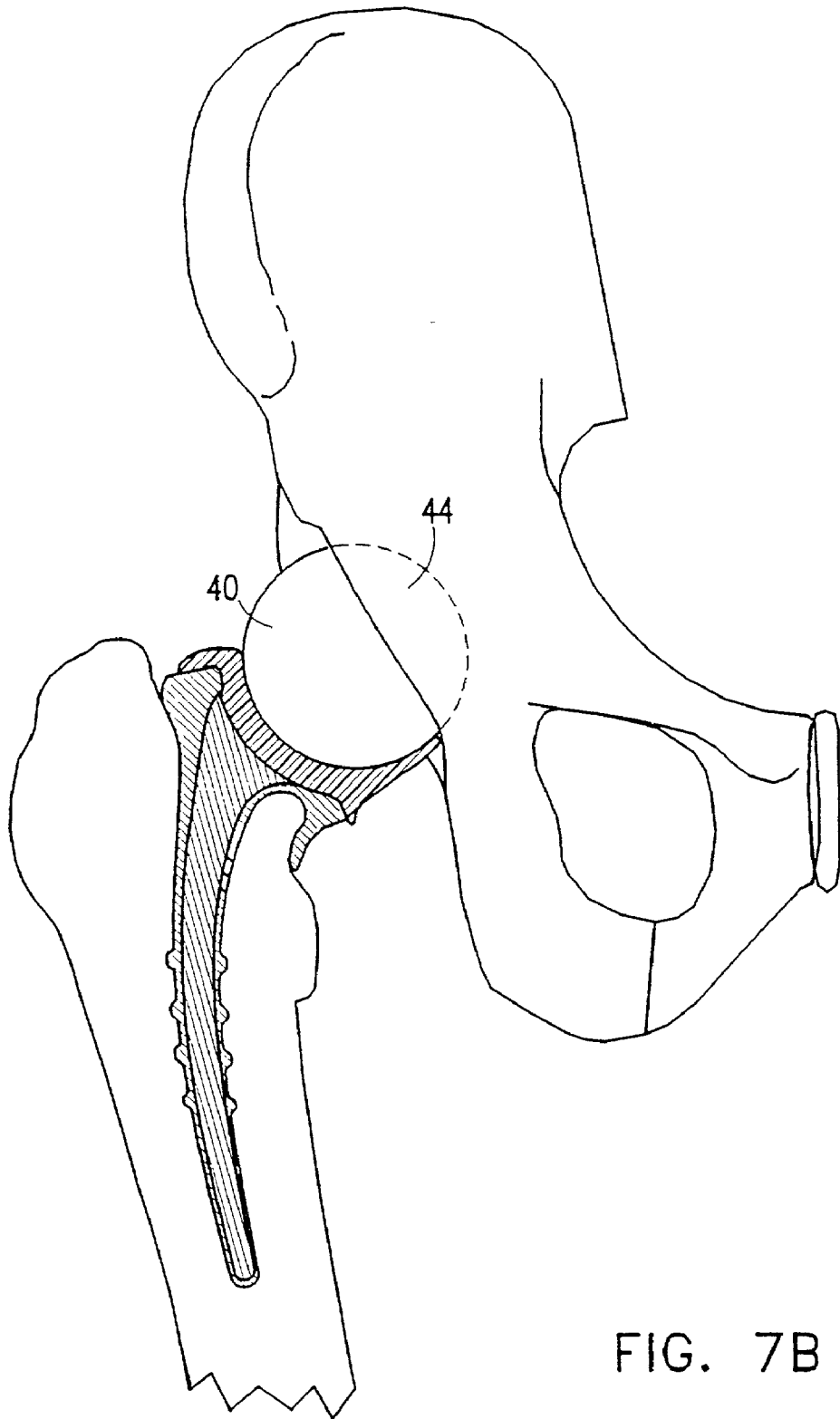

FIG. 7B

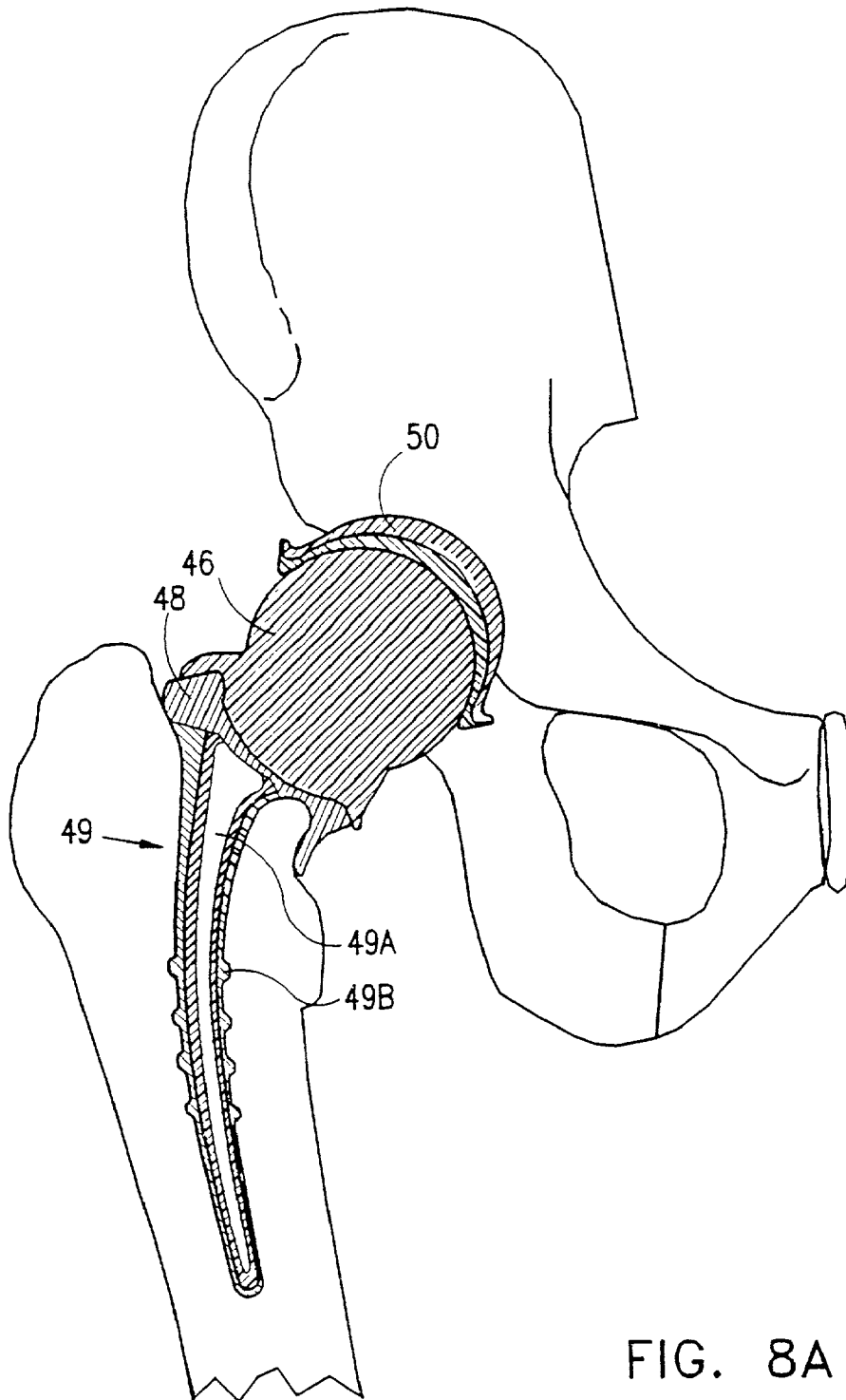

FIG. 8A

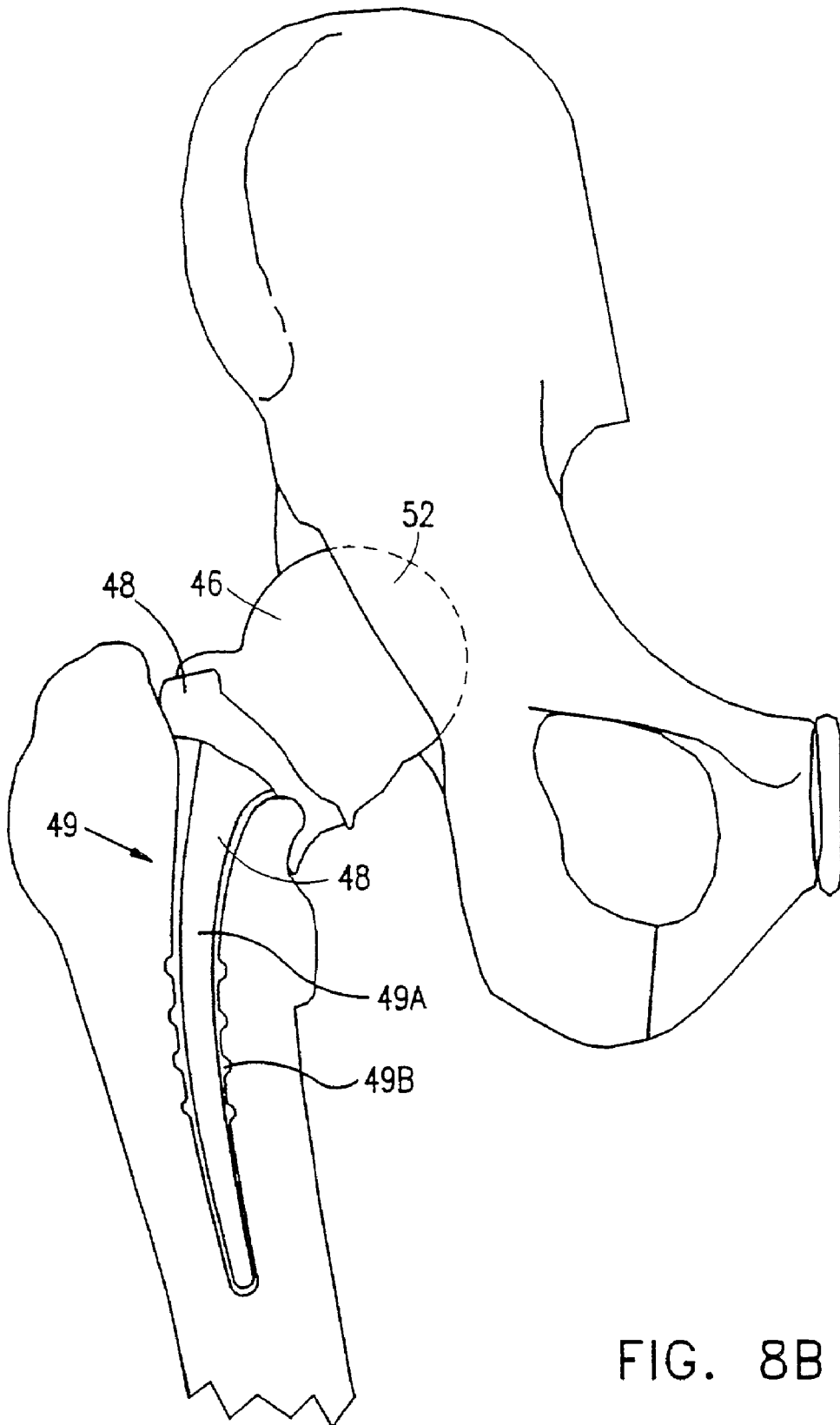

FIG. 8B

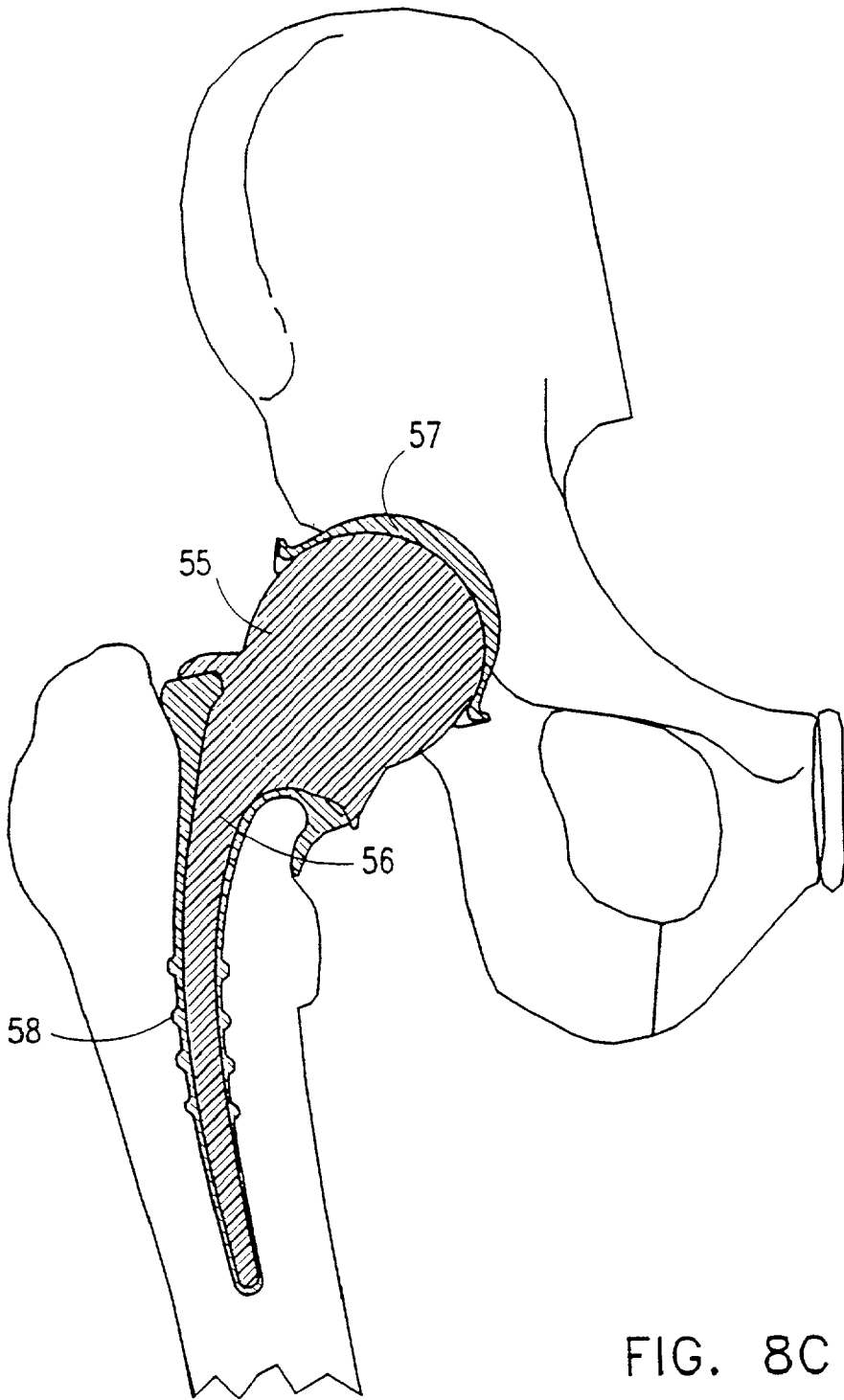

FIG. 8C

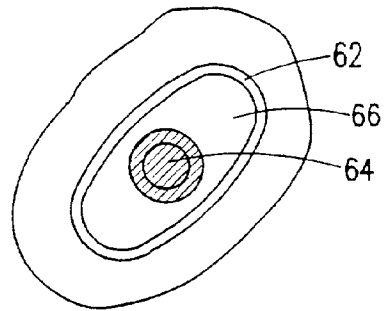

FIG. 9B

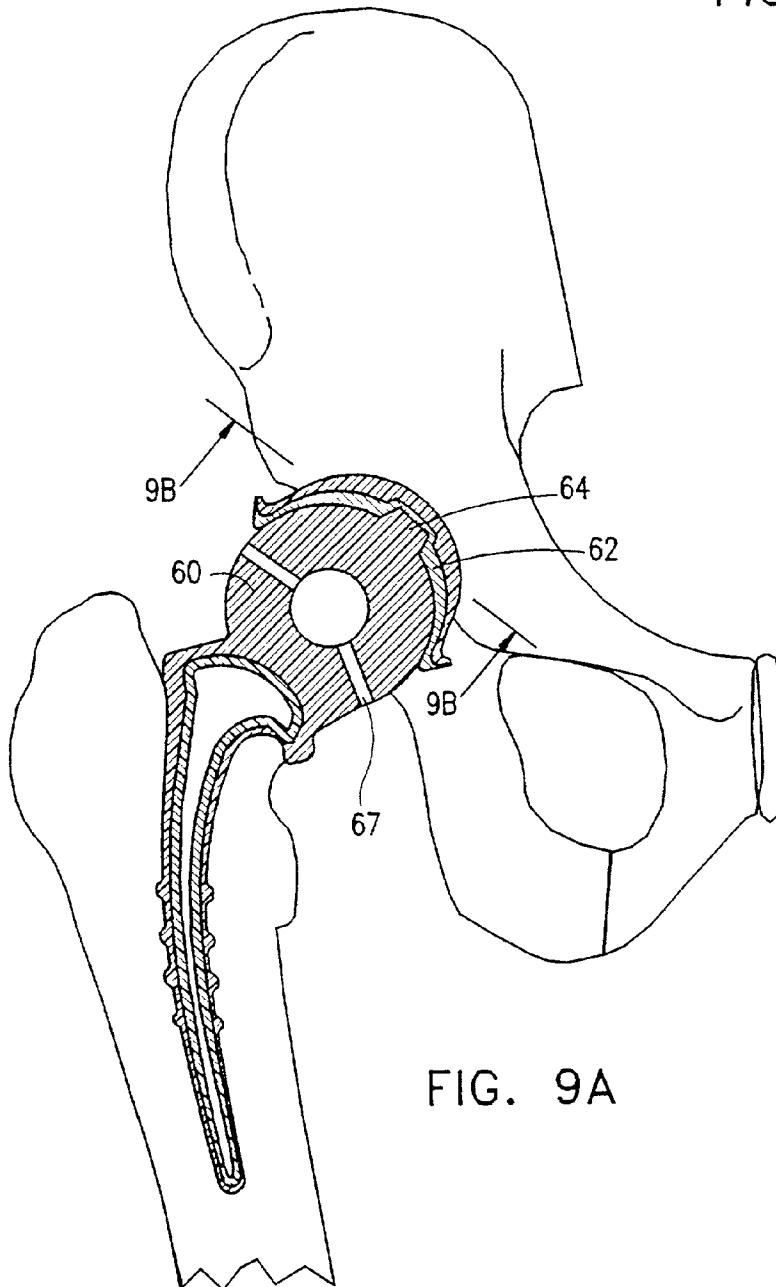

FIG. 9A

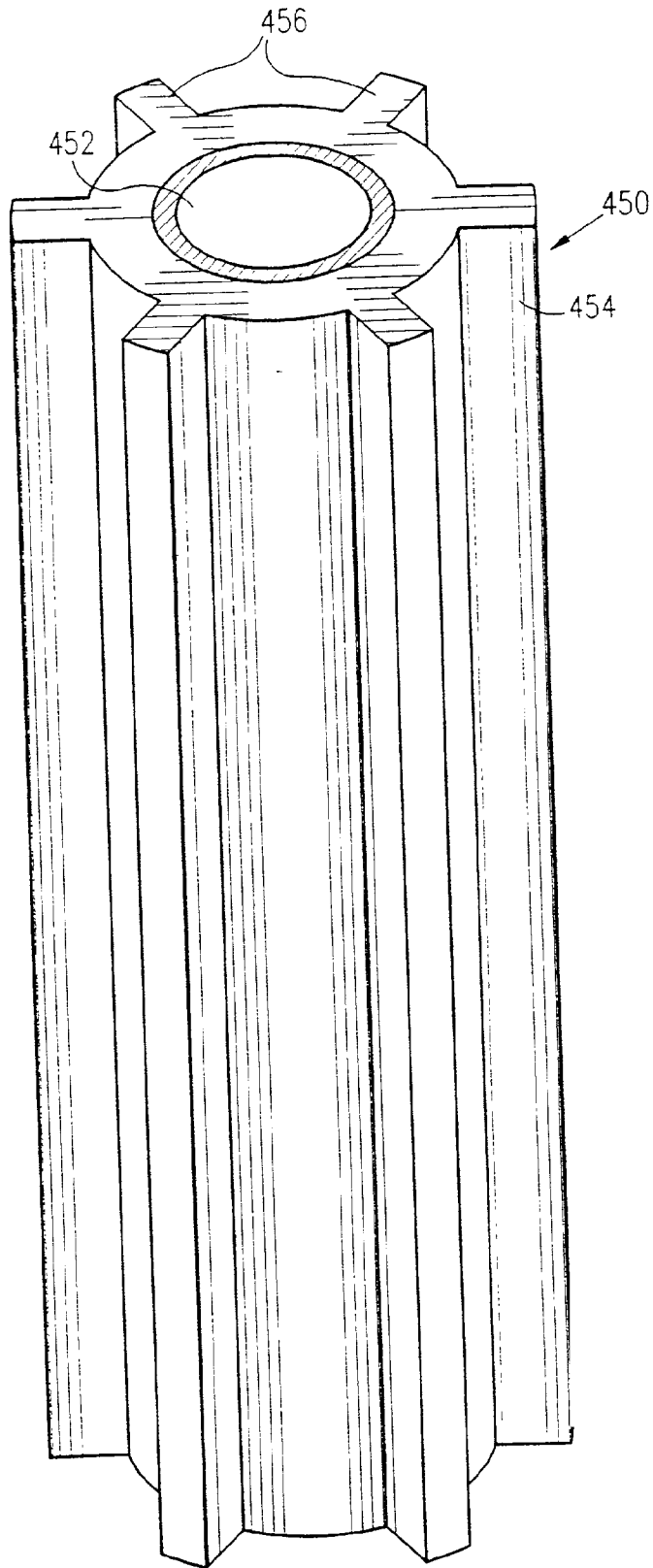

FIG. 9C

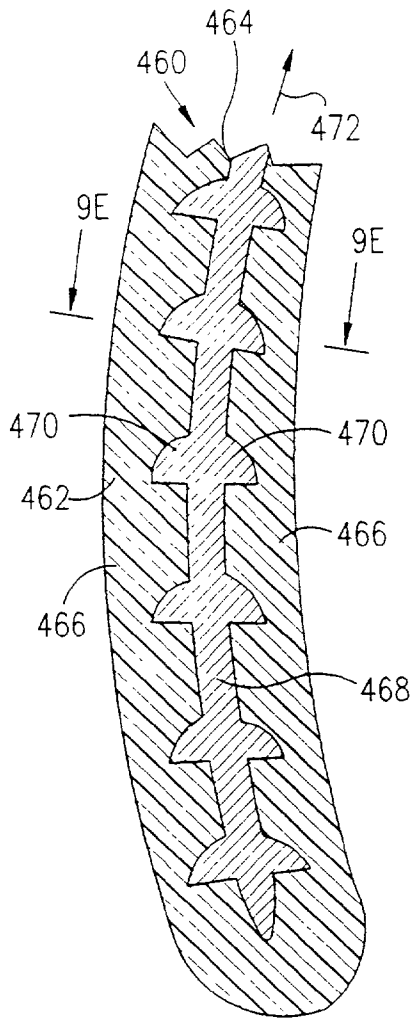

FIG. 9D

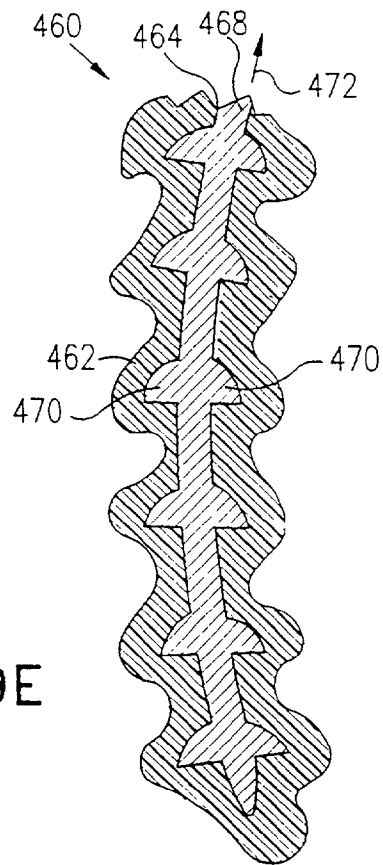

FIG. 9E

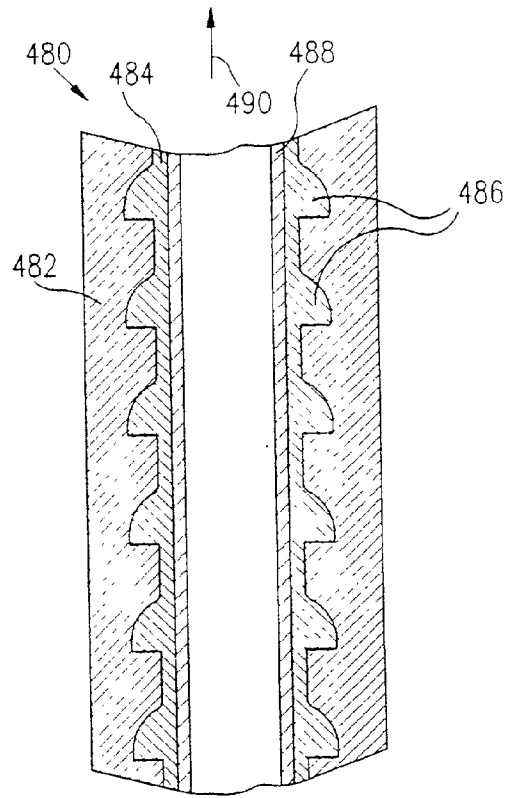

FIG. 9F

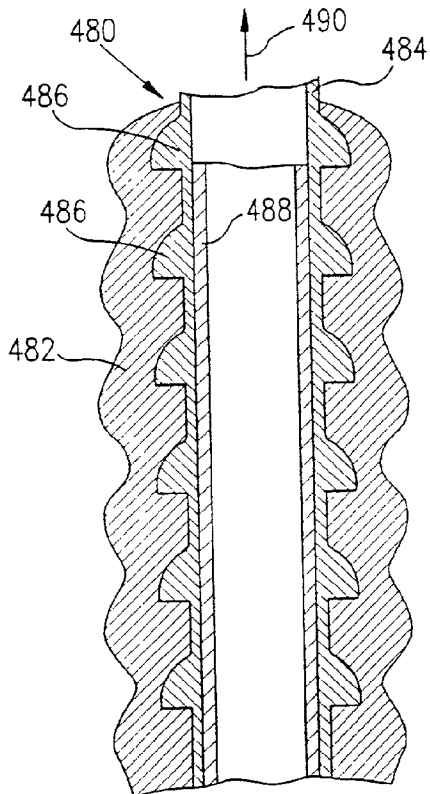

FIG. 9G

FIG. 11

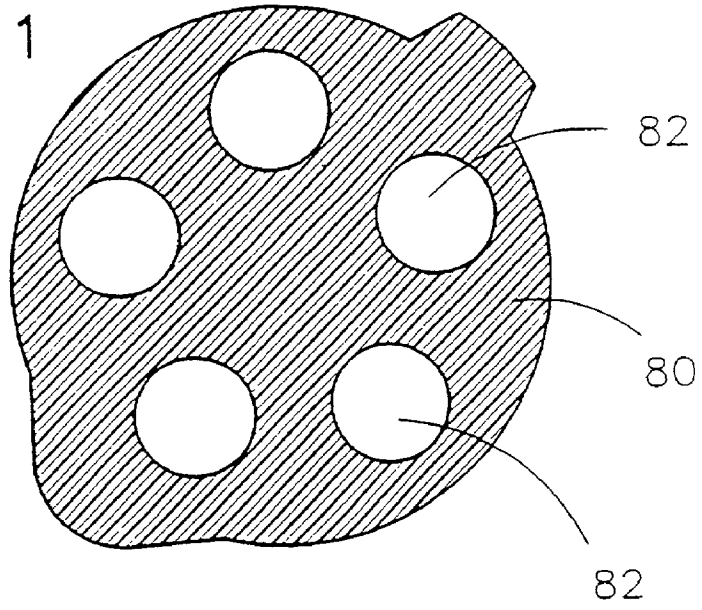
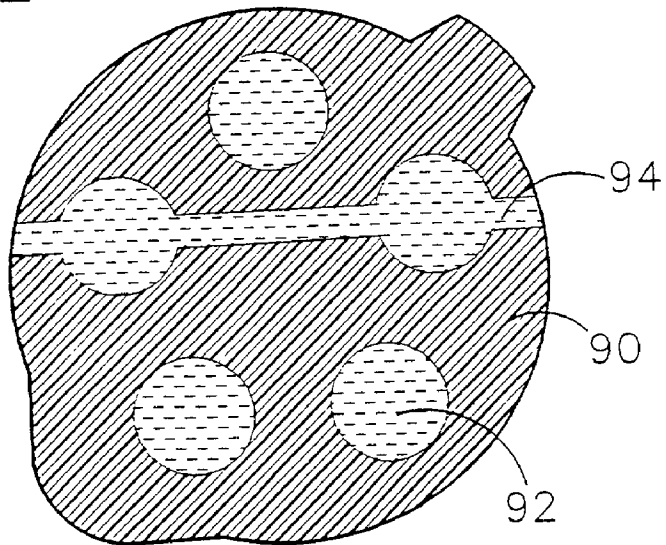

FIG. 12



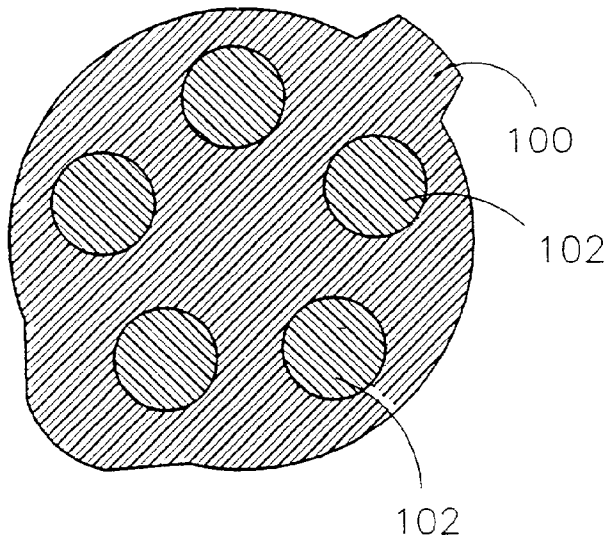

FIG. 13

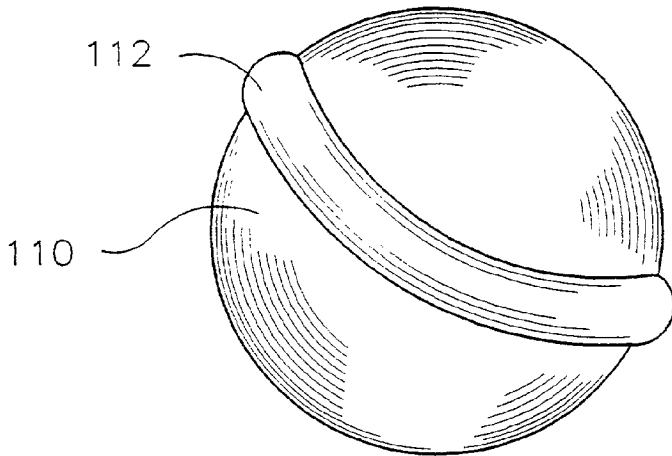

FIG. 14A

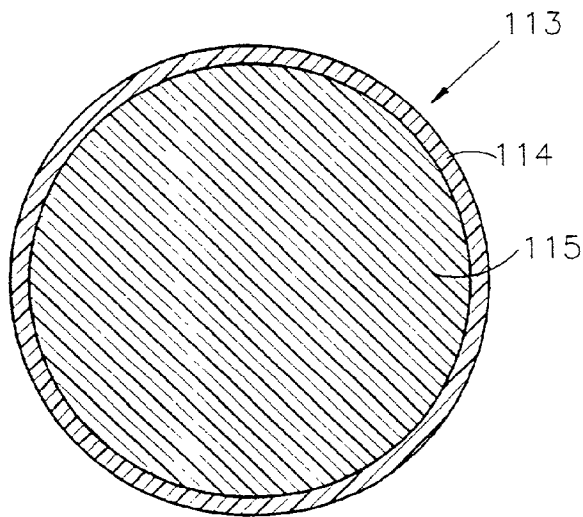

FIG. 14B

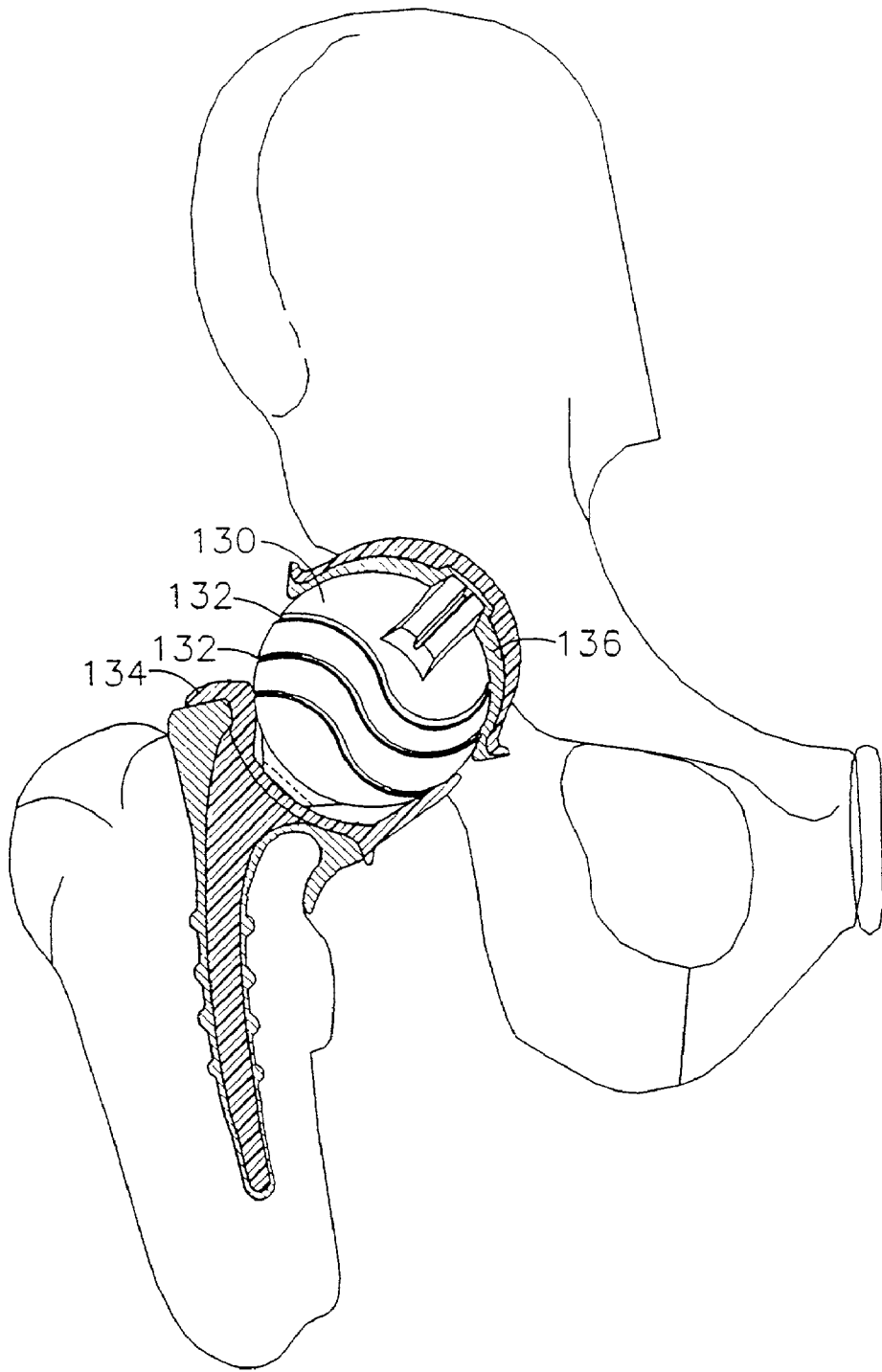

FIG. 16

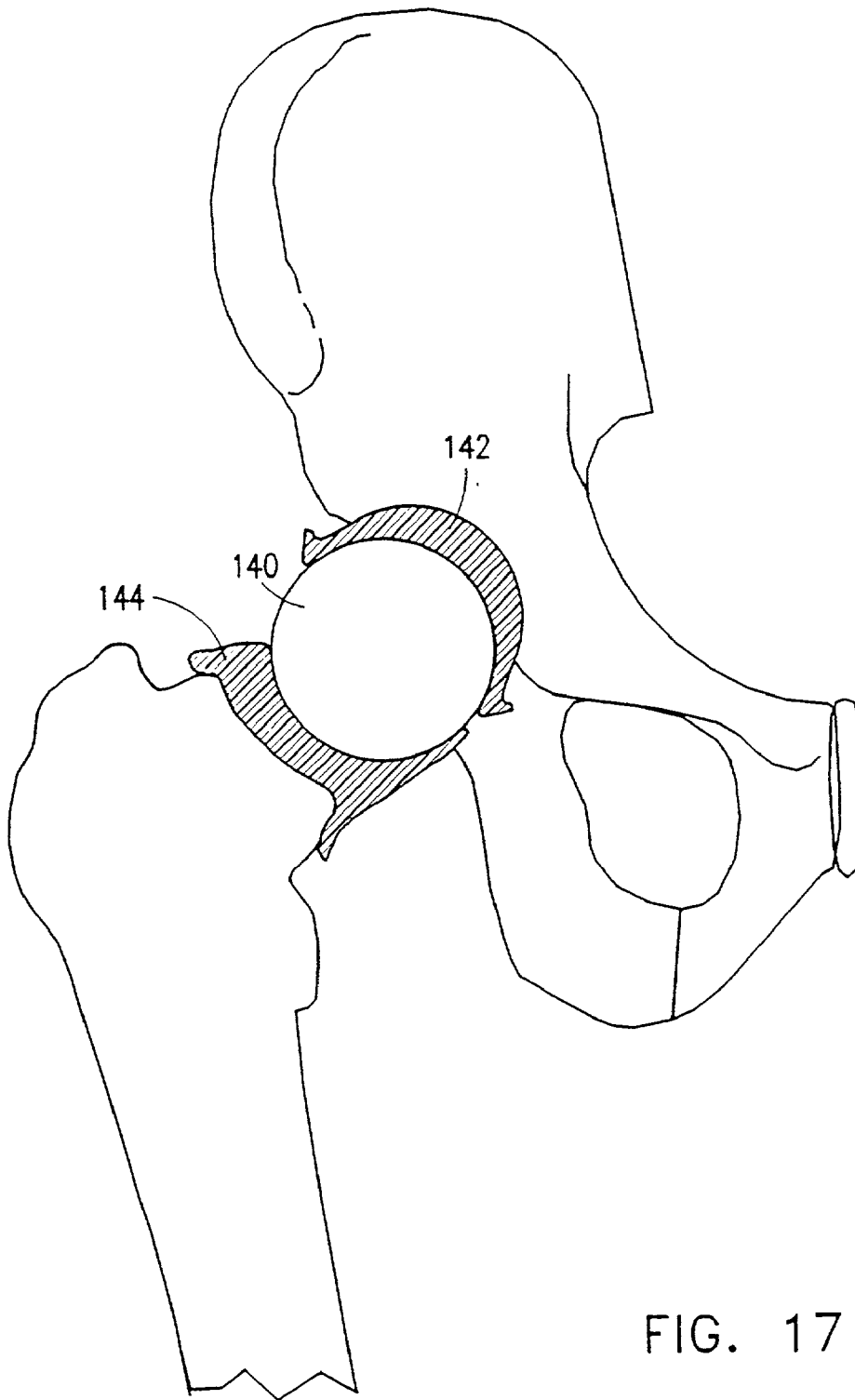

FIG. 17

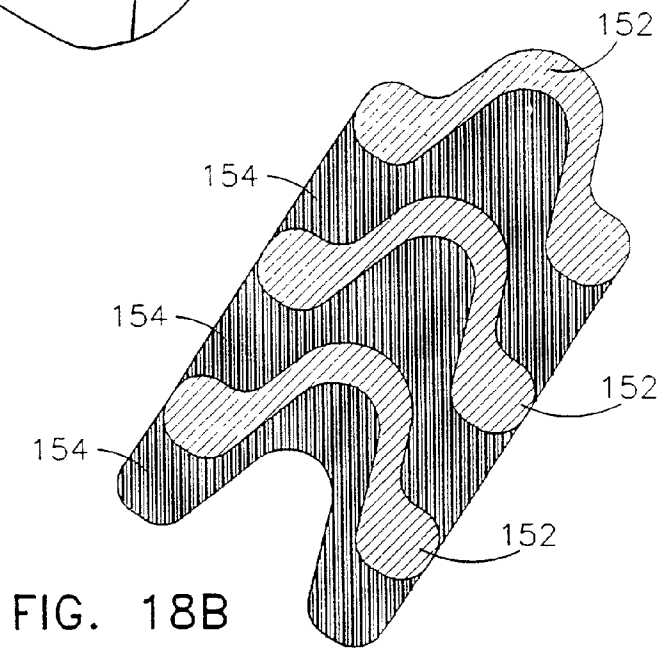
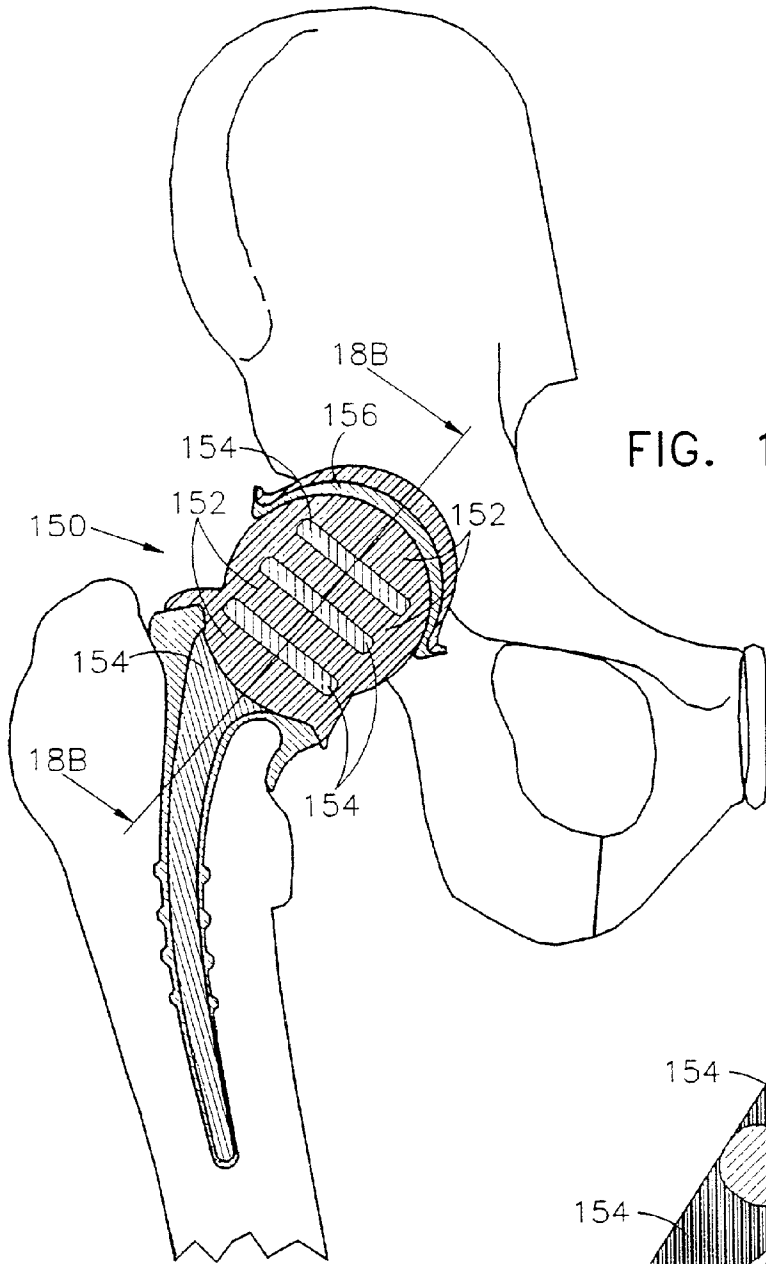

FIG. 18C

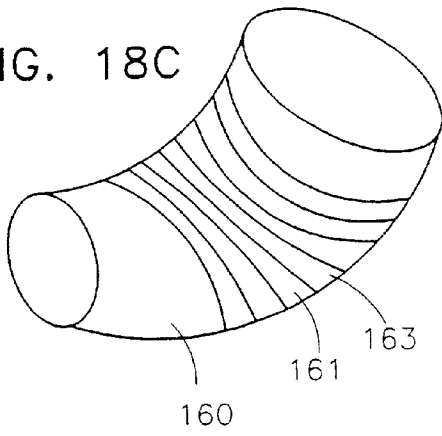

FIG. 18D

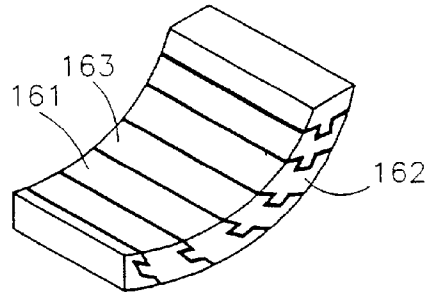

FIG. 18E

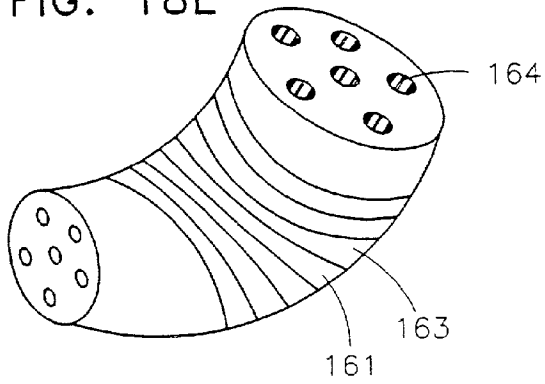
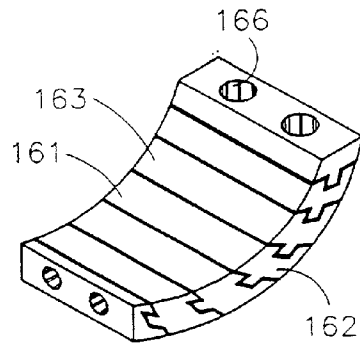

FIG. 18F



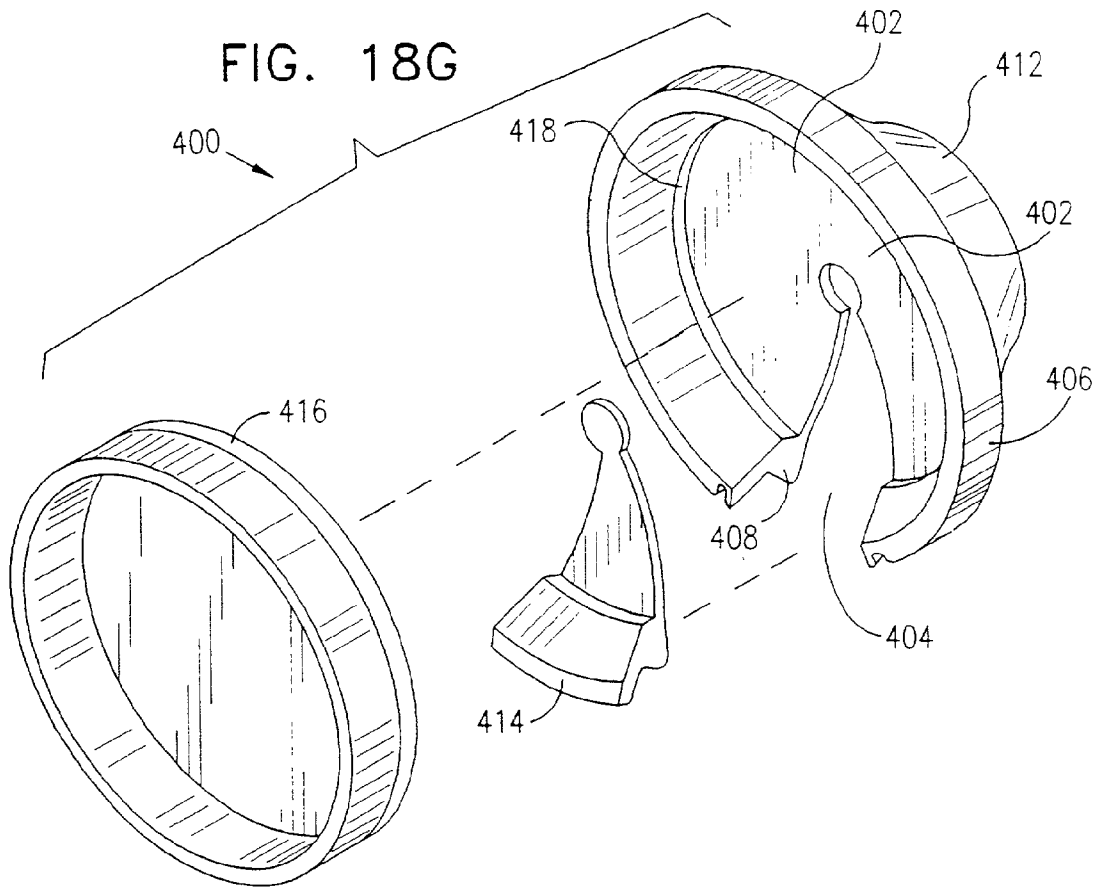

FIG. 18H

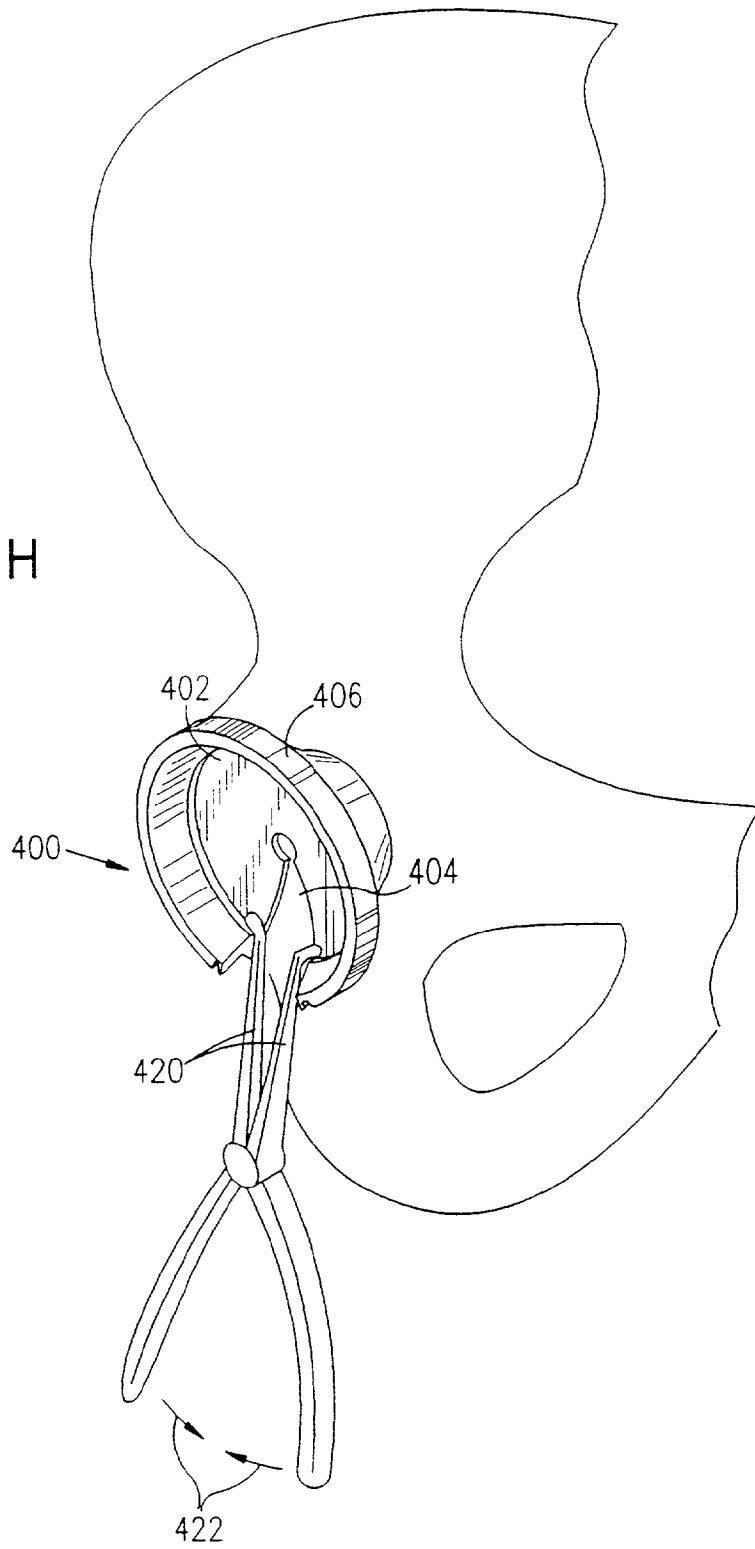

FIG. 18I

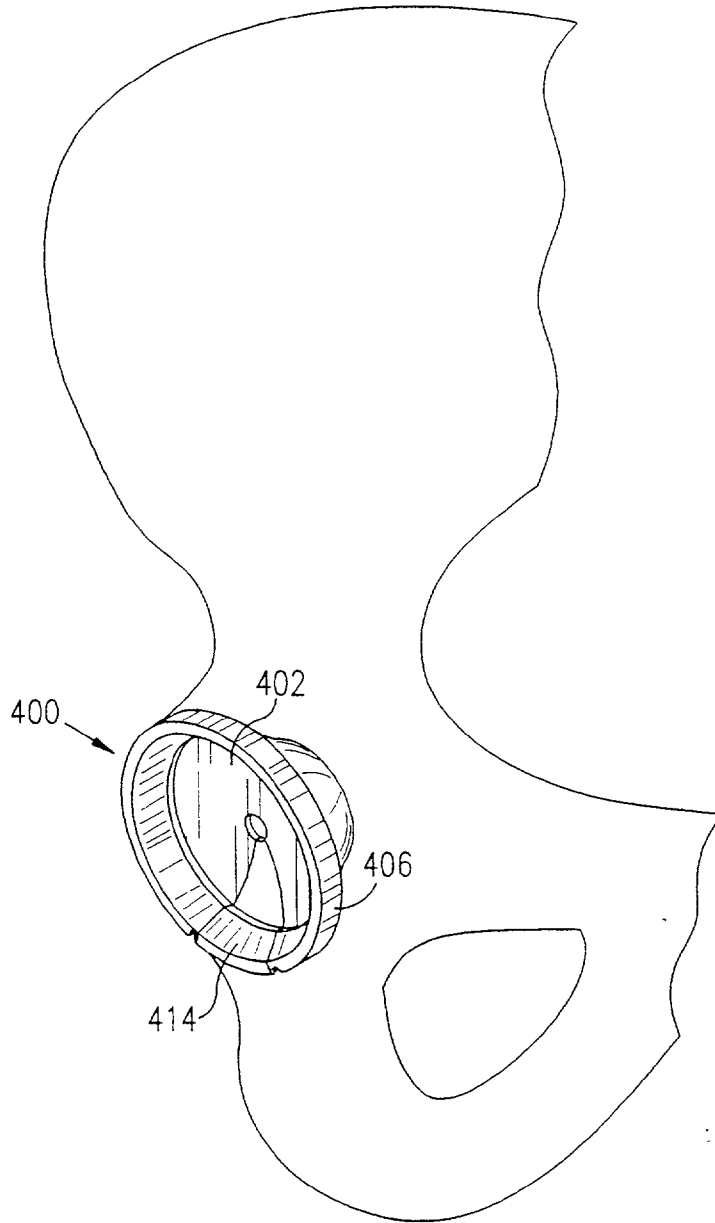

FIG. 18J

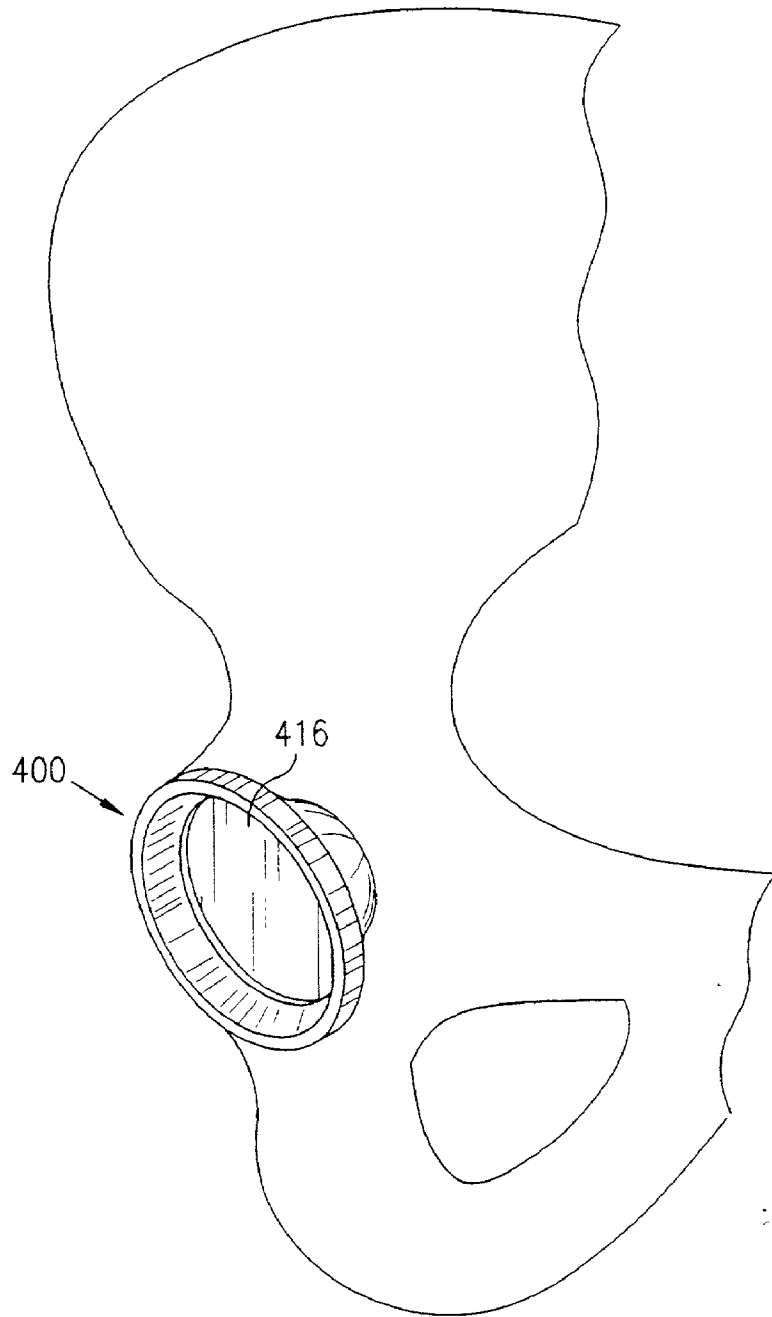

FIG. 18K

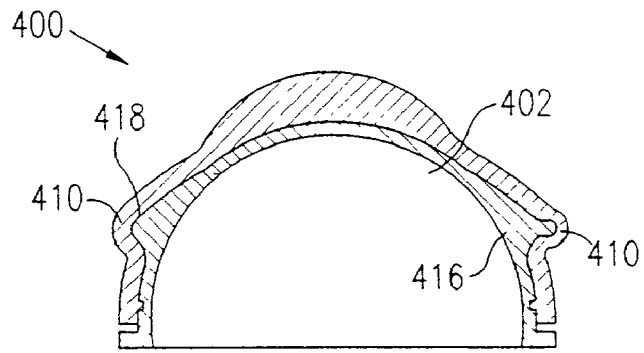
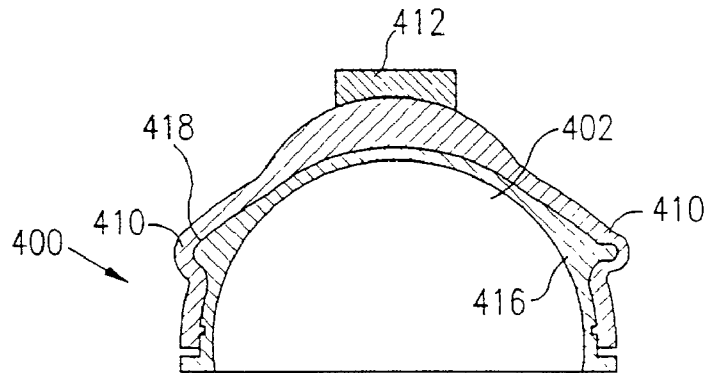

FIG. 18L



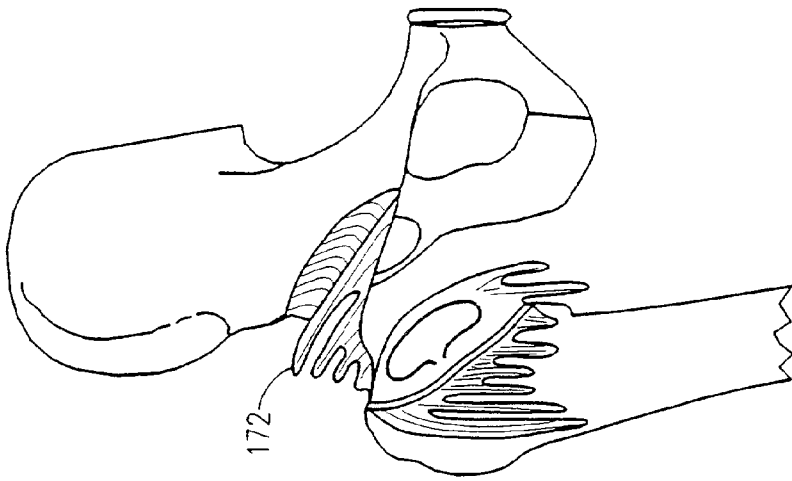

FIG. 19C

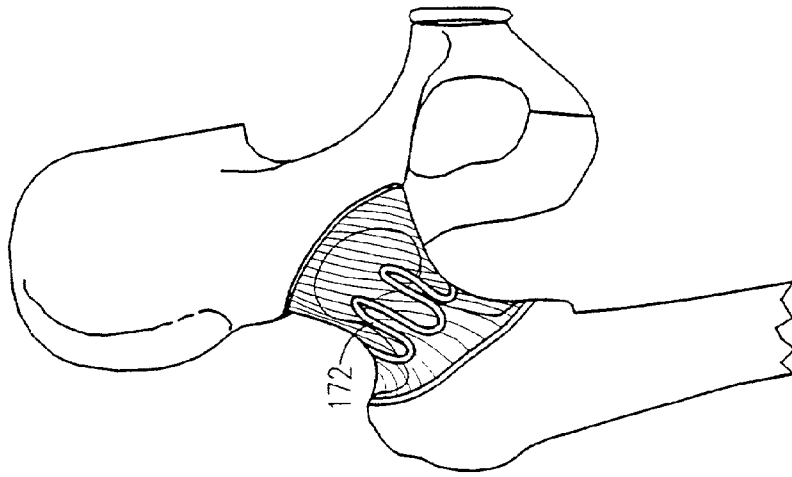

FIG. 19B

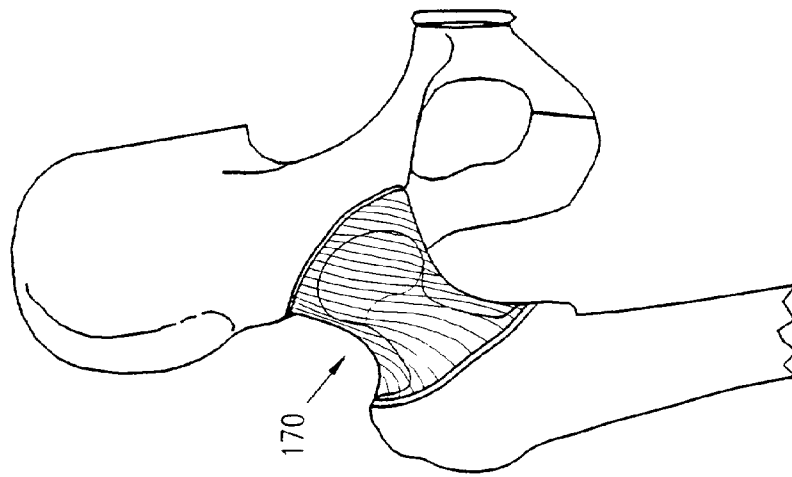

FIG. 19A

FIG. 20

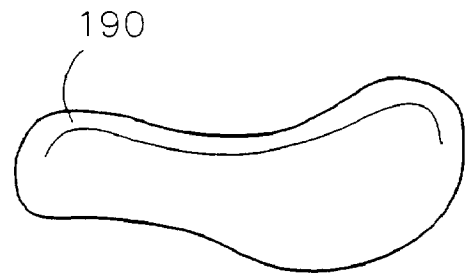
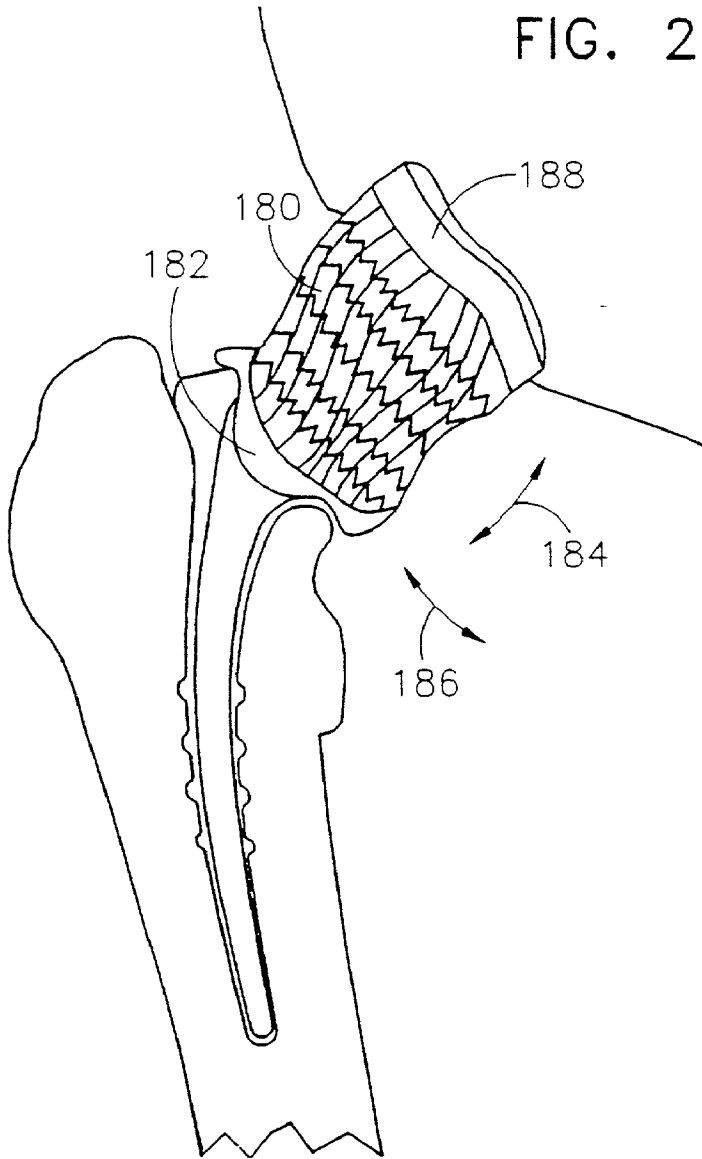
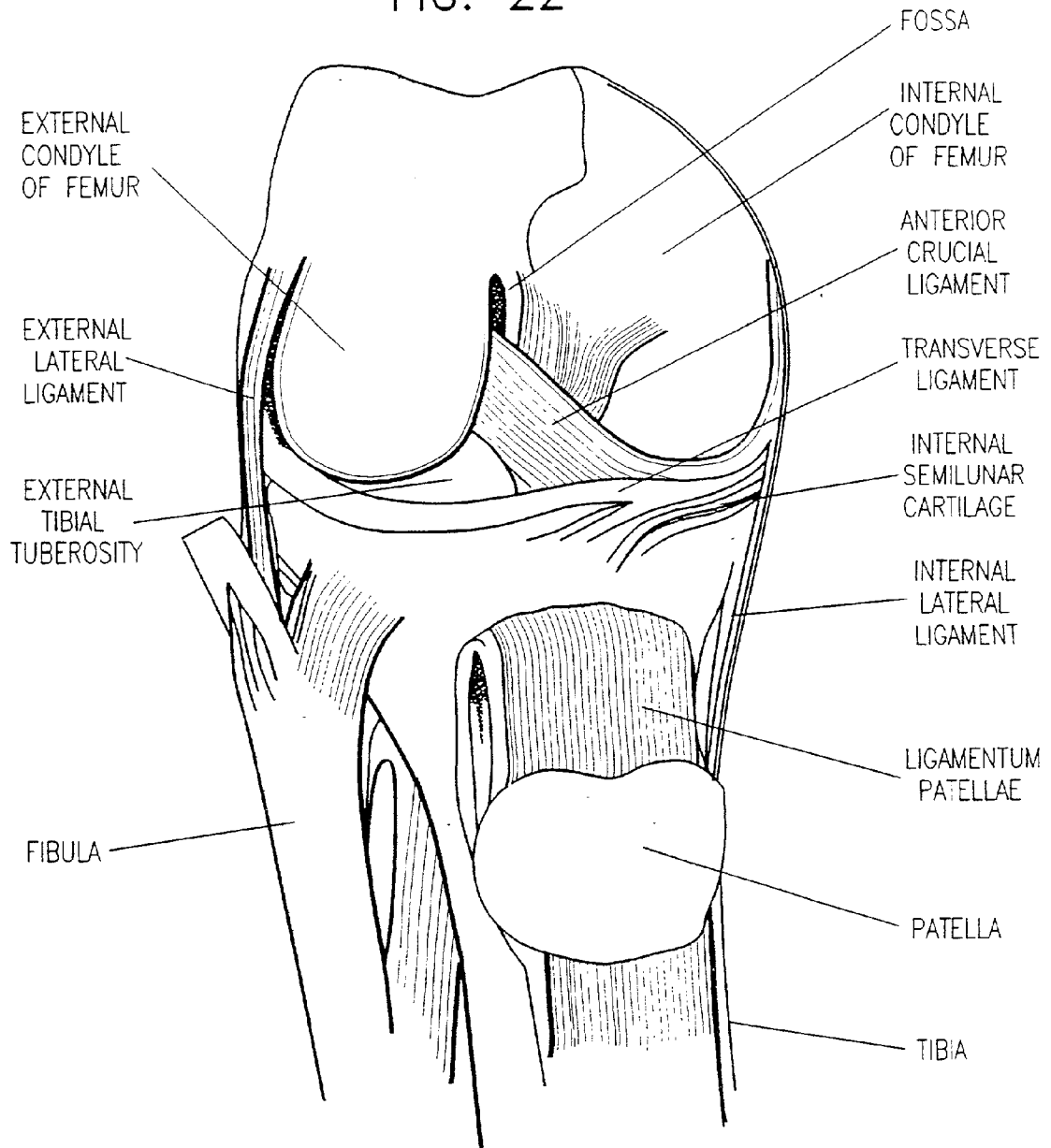

FIG. 21

FIG. 22



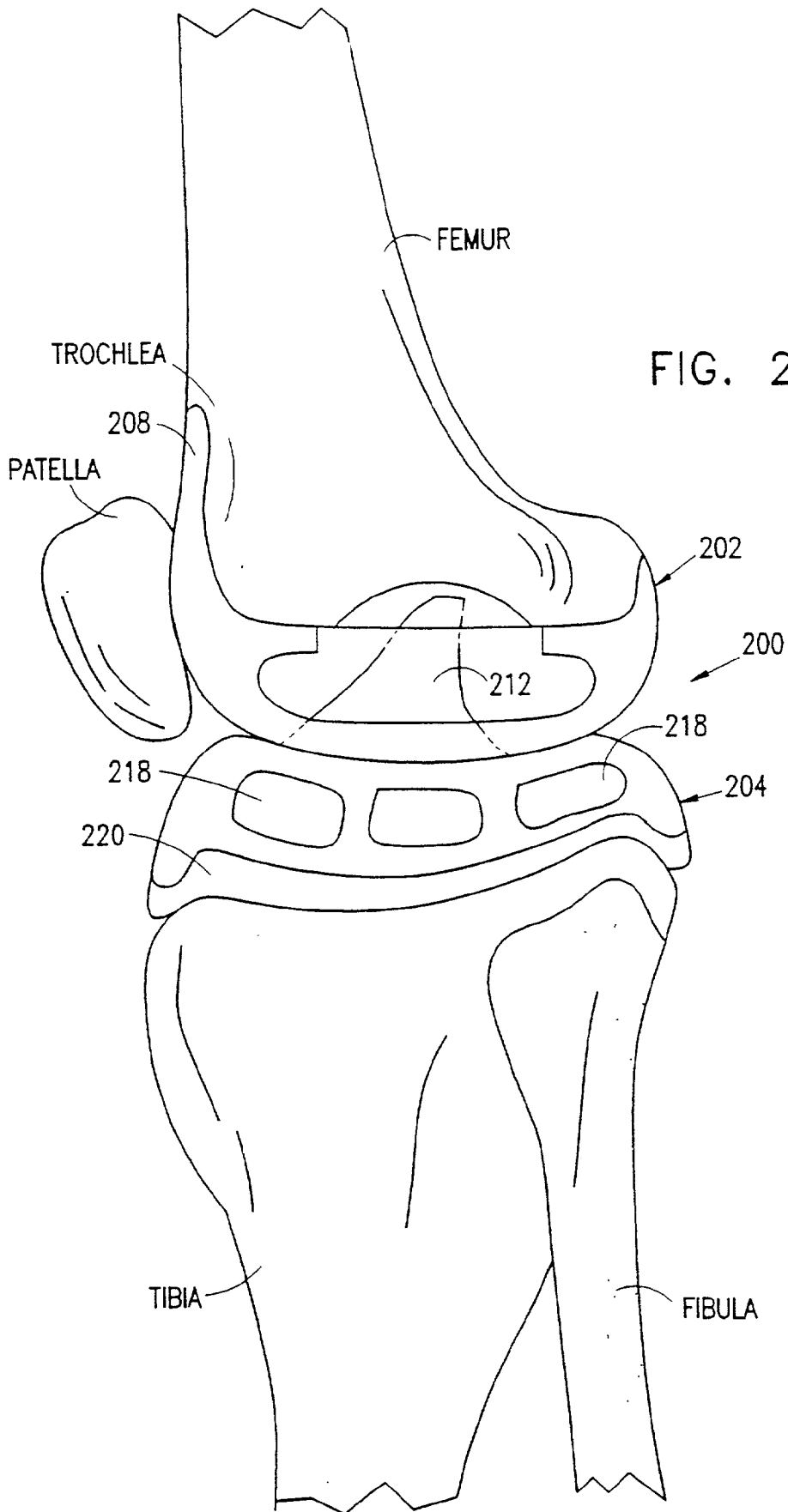

FIG. 24

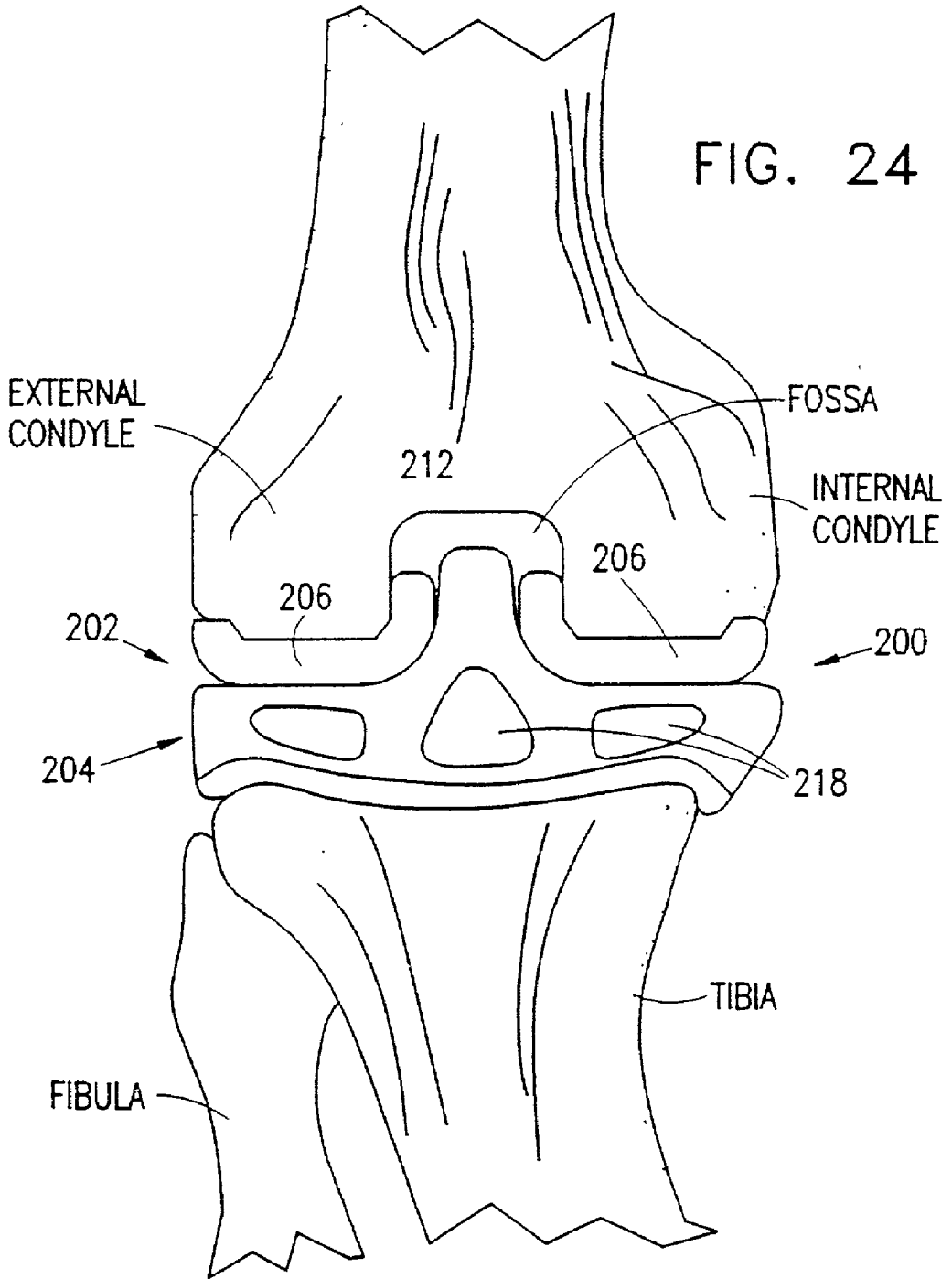

FIG. 25

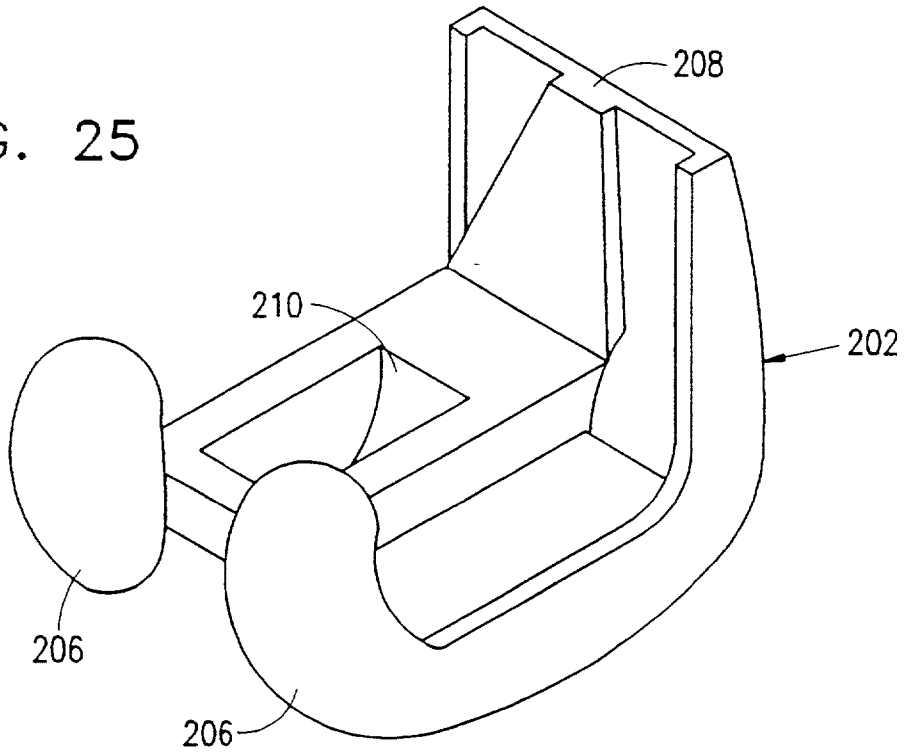
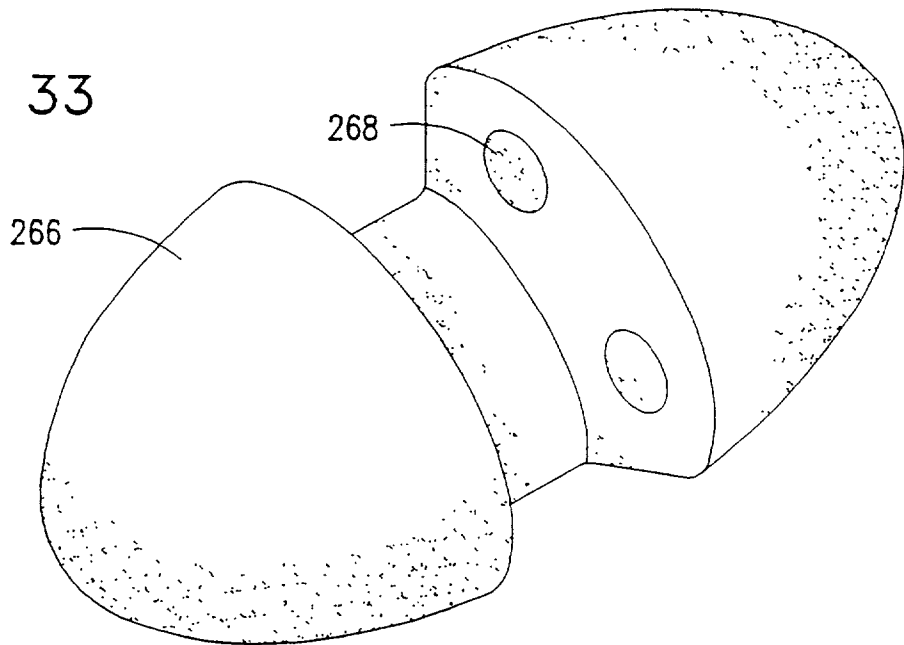

FIG. 33



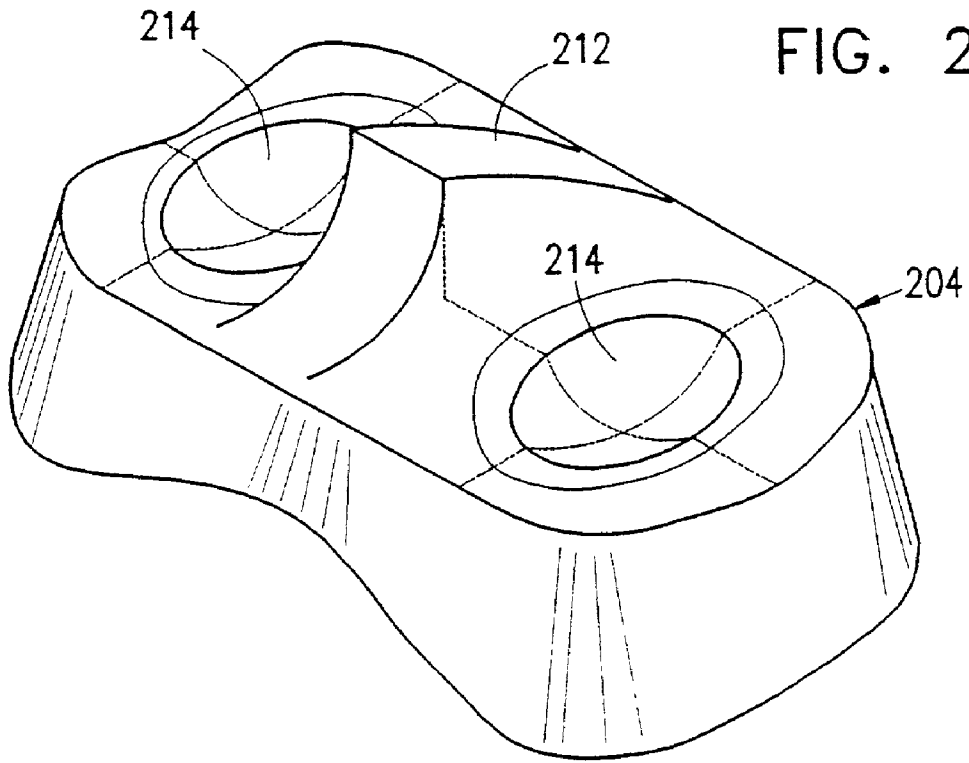
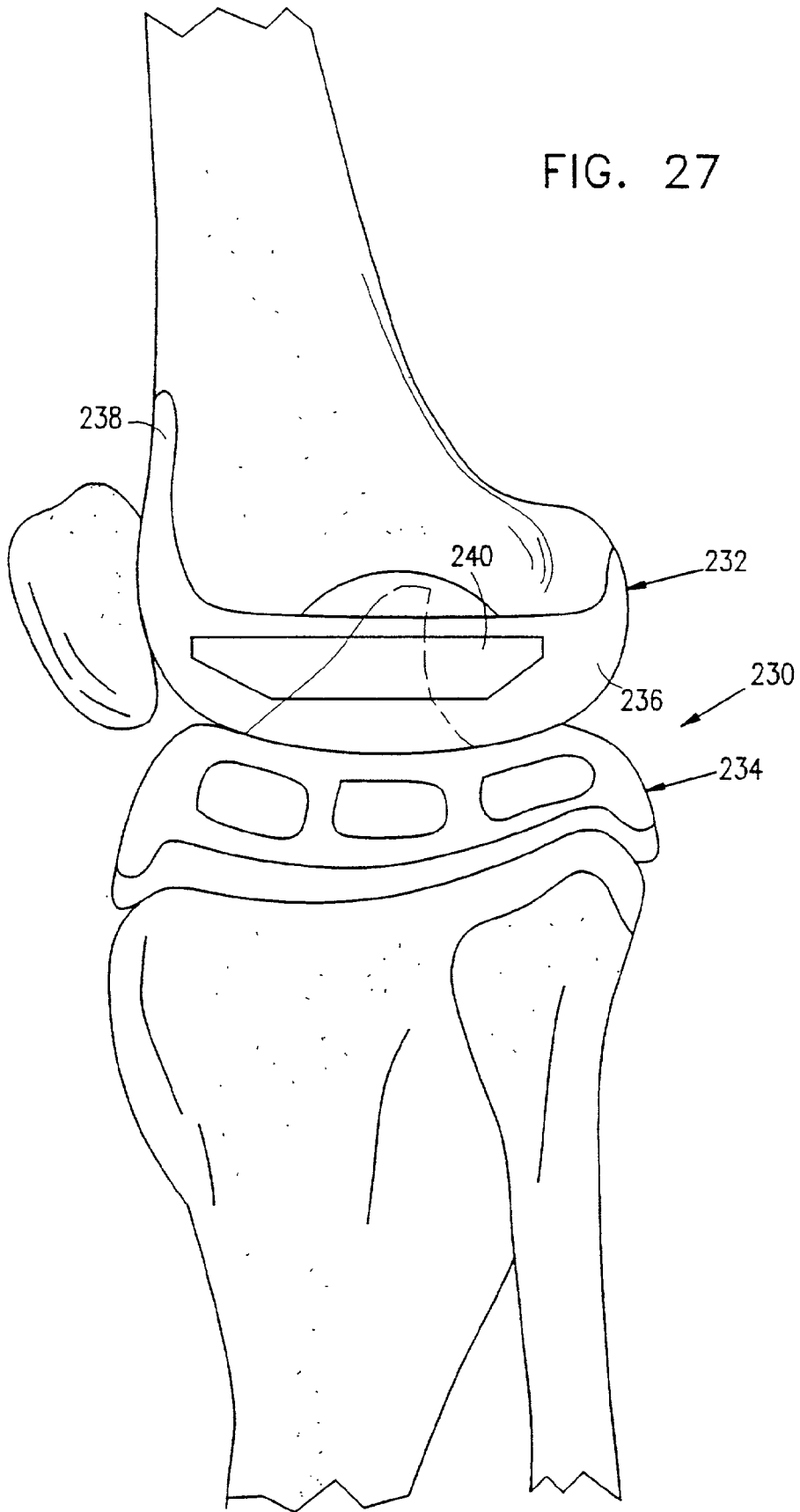

FIG. 27



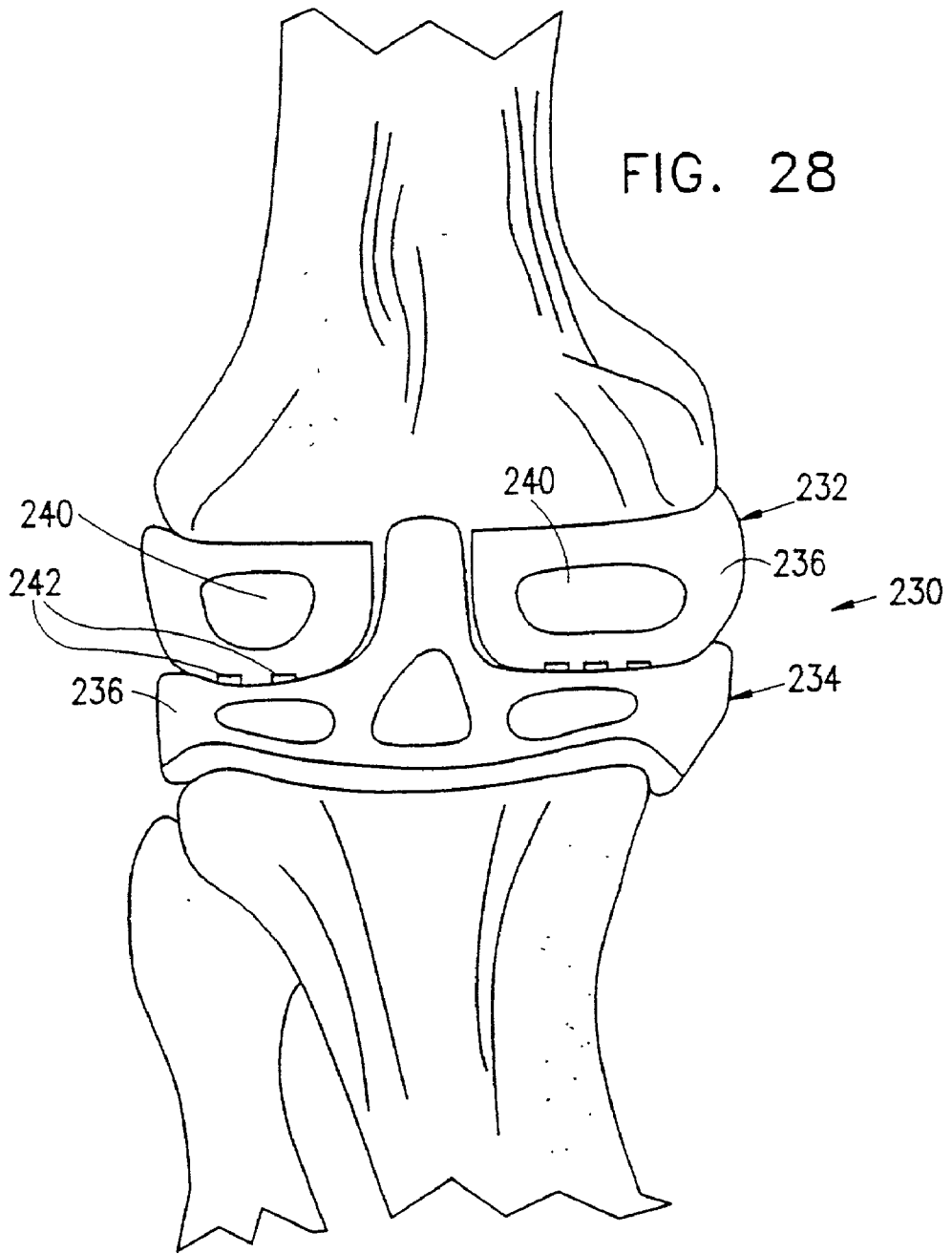

FIG. 29

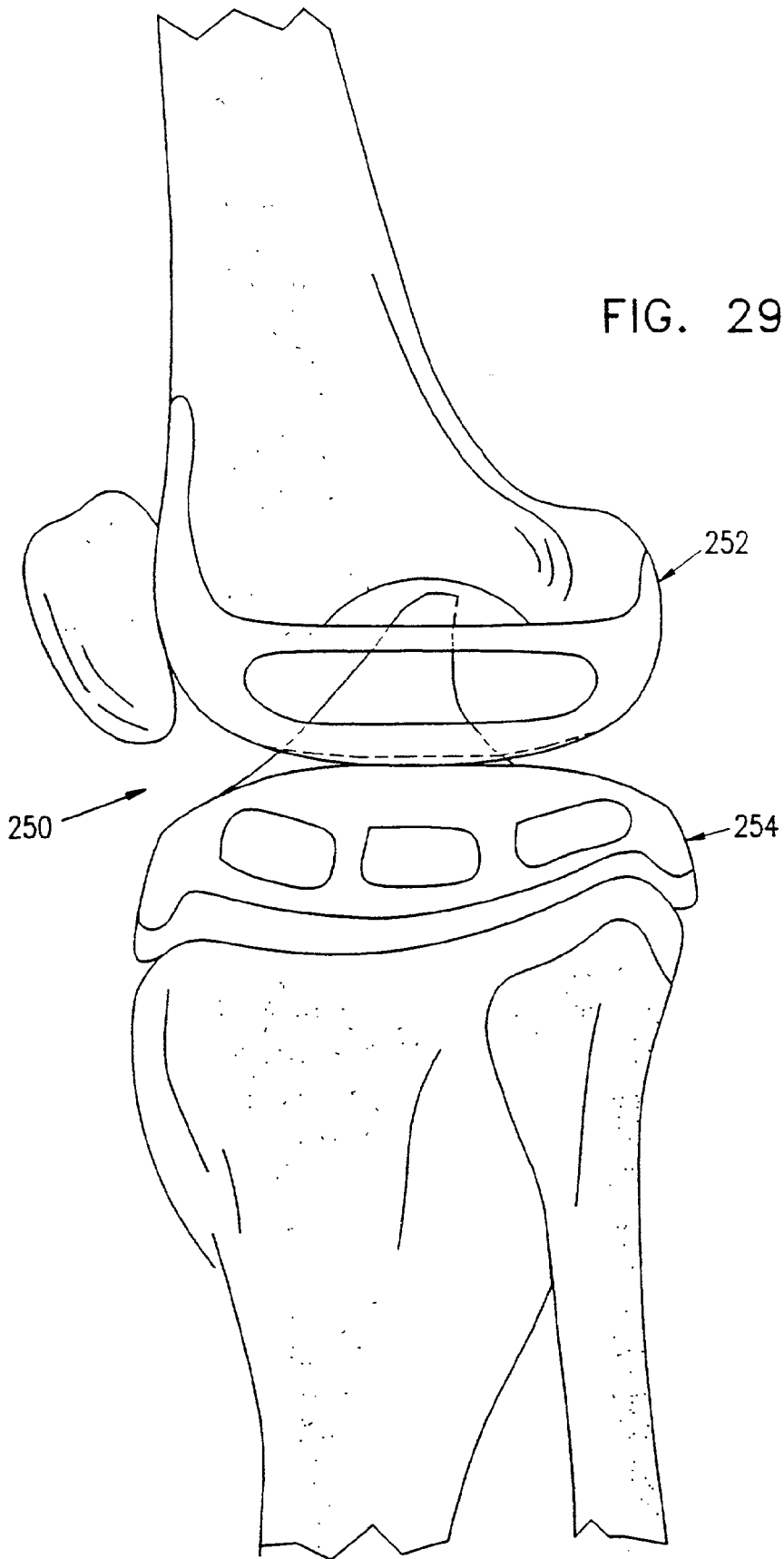

FIG. 30

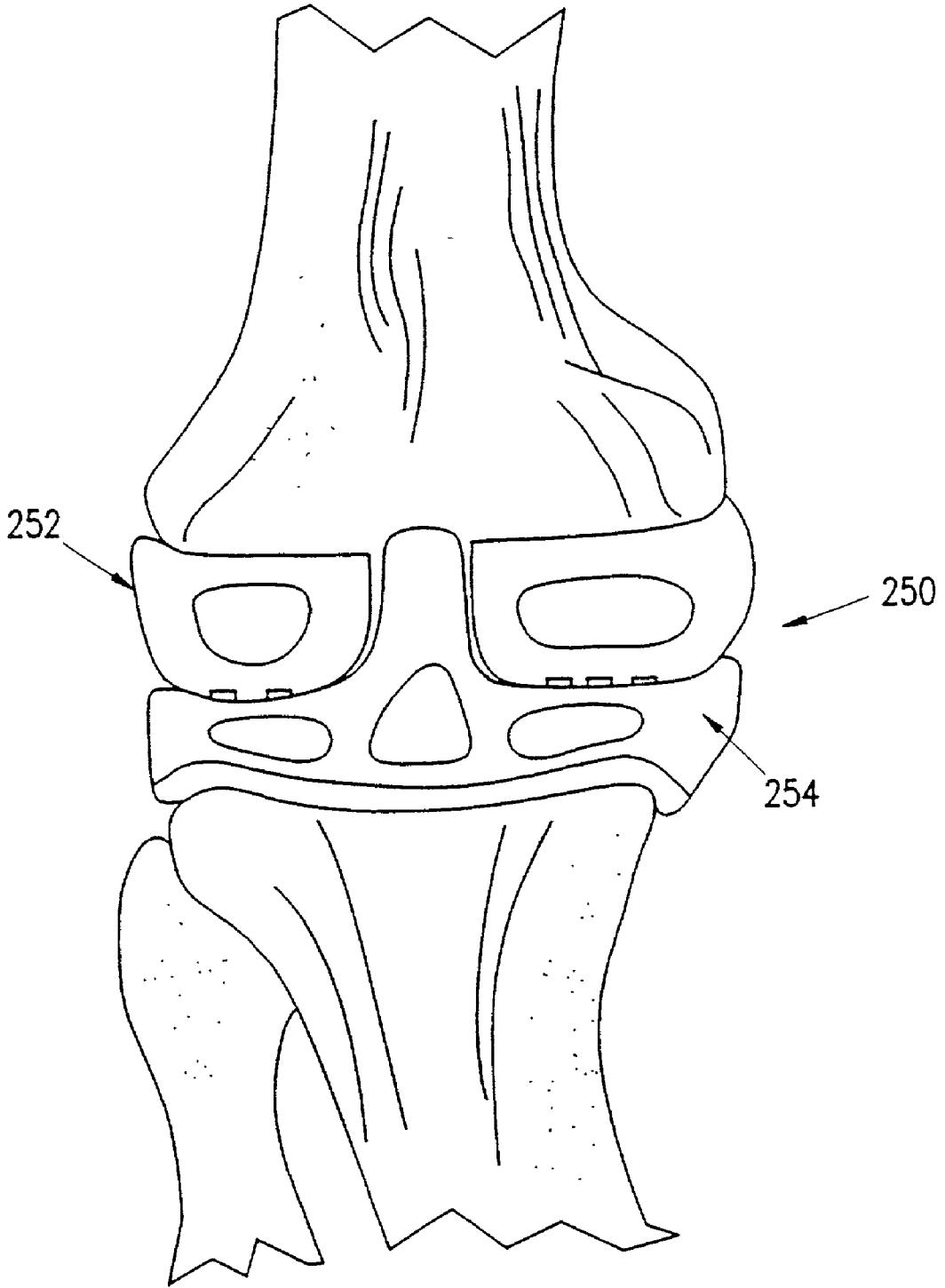
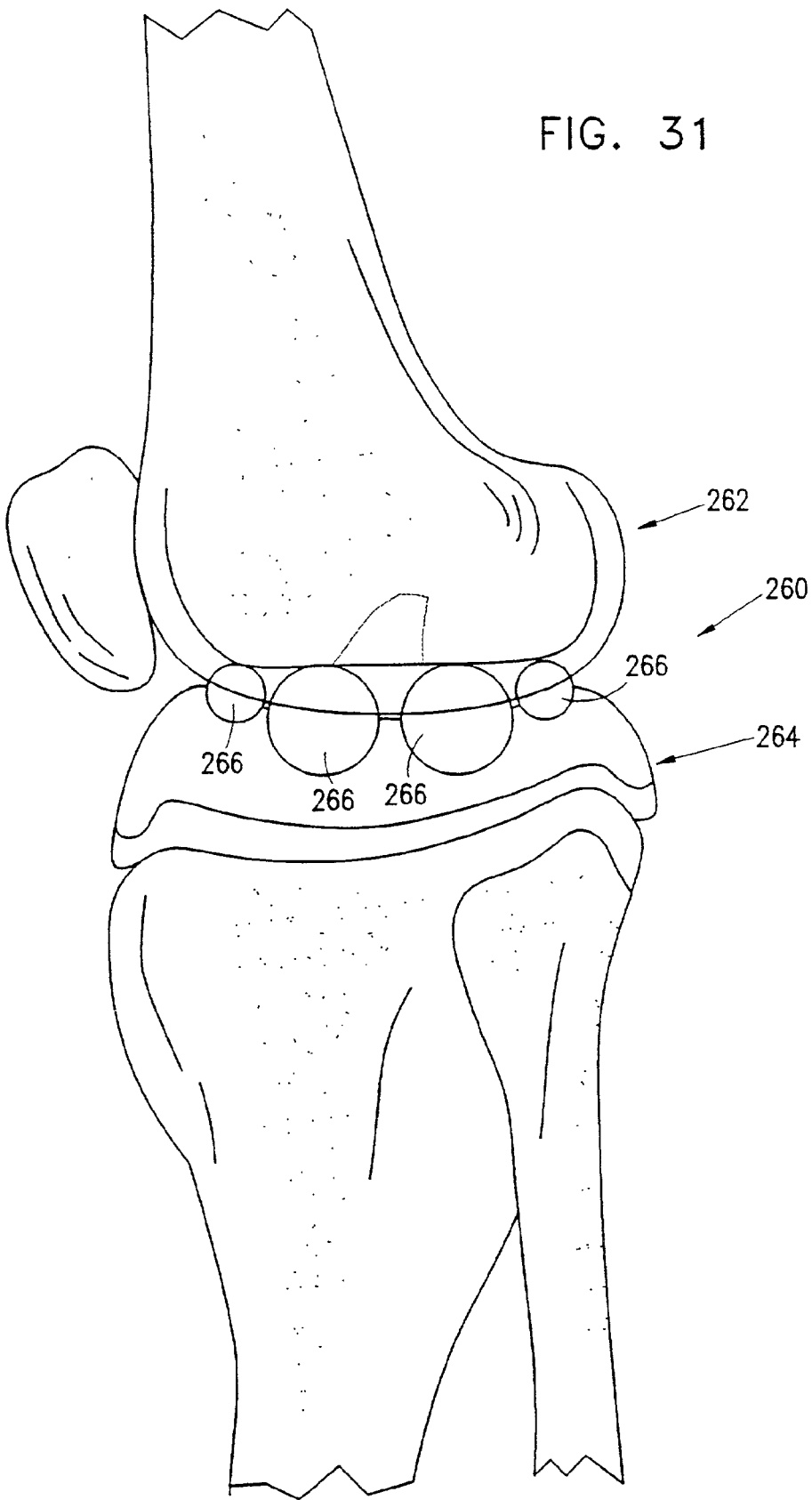

FIG. 31



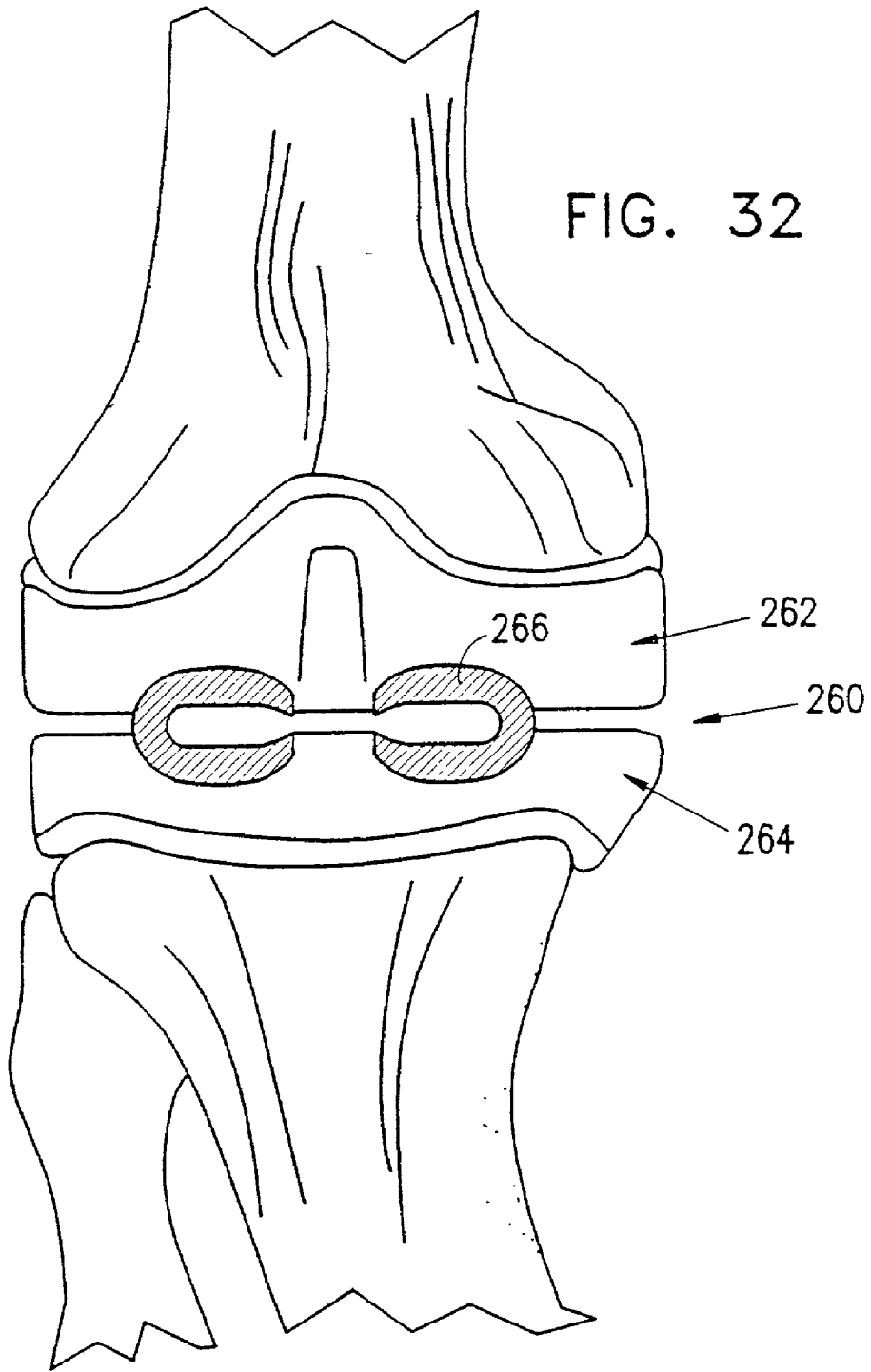

FIG. 35

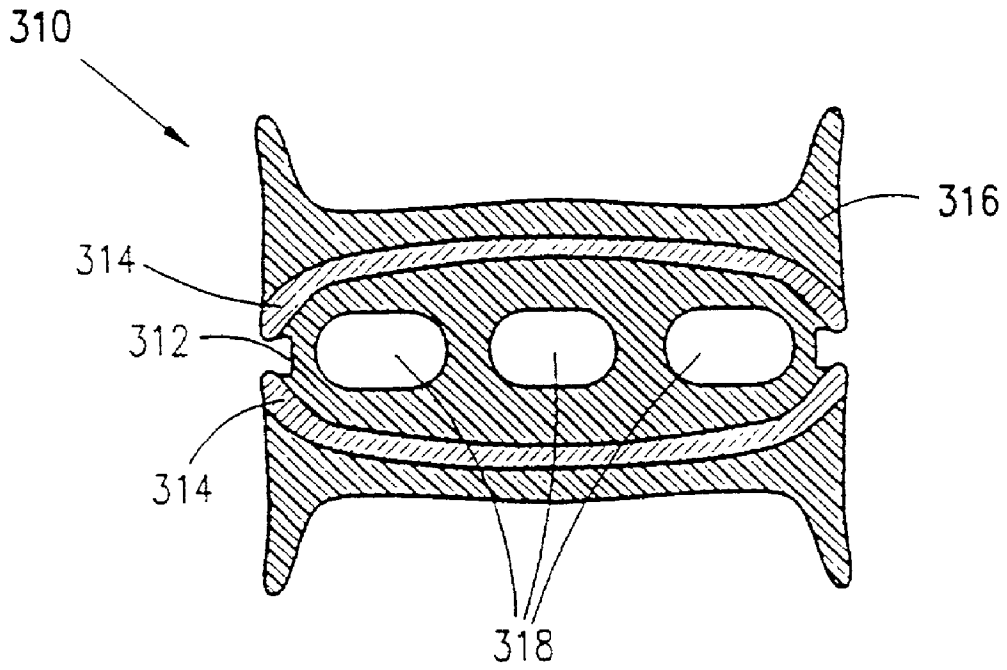
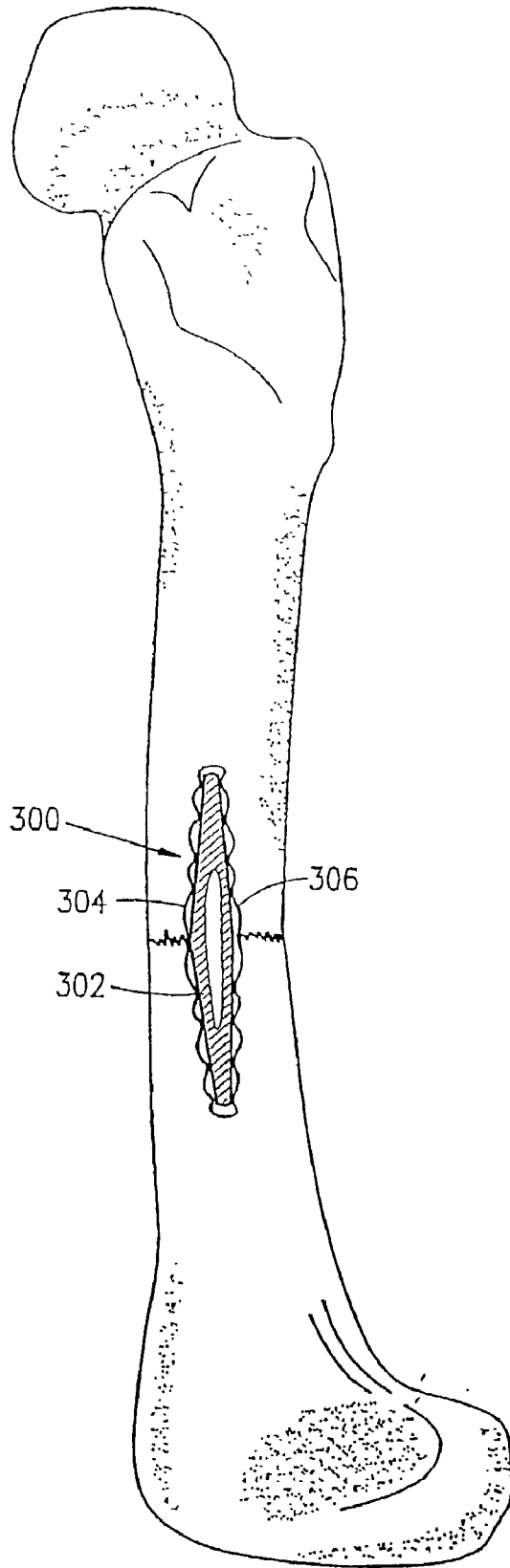

FIG. 34



HIP JOINT PROSTHESES

[0001] The present invention relates to apparatus and methods for joint prosthesis surgery generally.

[0002] Joint prostheses are well known in the art. Generally joint prostheses include a metal portion, typically constructed of steel or titanium, which articulates with a bony portion of the body. Non-articulating portions of the prosthesis are generally fixedly attached to tissue or bone. For example, a hip joint prosthesis of the art generally includes a metallic femoral head which articulates with a portion of the hip bone, and a metallic stem which is fixedly attached to the femur.

[0003] Several problems are associated with prostheses of the art, for example, due to the mismatch between material properties of the prosthesis and bone. The contact between metal and bone may cause fretting wear of the bone. The difference in coefficient of thermal expansion between metal and bone may cause discomfort to the patient, especially during weather changes. The metallic prosthesis provides virtually no shock absorption or damping.

[0004] It is known that a bone grows or regenerates according to the stress which it must bear. The metal prosthesis generally bears a much larger portion of weight than the surrounding bone. The reduced stress on the surrounding bone may tend to contribute to degeneration and recession of the bone, and to create an undesirable gap between the bone and the prosthesis.

[0005] In order to overcome the aforementioned problems, a great variety of prostheses with resilient portions have been proposed and developed. The following U.S. Patents are believed to be representative of the art: U.S. Pat. No. 5,522,904, 5,514,184, 5,514,182, 5,507,836,

5,507,833,	5,507,830,	5,507,823,	5,507,820,	5,507,818,
5,507,814,	5,491,882,	5,489,311,	5,458,651,	5,458,643,
5,448,489,	5,425,779,	5,415,662,	5,405,411,	5,405,403,
5,389,107,	5,387,244,	5,376,125,	5,376,064,	5,370,699,
5,358,525,	5,344,459,	5,336,268,	5,330,534,	5,326,376,
5,316,550,	5,314,494,	5,314,493,	5,314,478,	5,290,314,
5,282,868,	5,222,985,	5,217,499,	5,217,498,	5,201,882,
5,201,881,	5,197,989,	5,197,987,	5,181,925,	5,171,276,
5,156,631,	5,151,521,	5,147,406,	5,146,933,	5,133,763,
5,116,374,	5,108,451,	5,108,446,	5,080,677,	5,049,393,
5,041,140,	5,019,107,	5,002,581,	4,997,447,	4,963,154,
4,963,153,	4,955,919,	4,955,912,	4,950,298,	4,938,773,
4,938,771,	4,936,856,	4,919,678,	4,919,674,	4,908,035,
4,904,269,	4,888,020,	4,822,365,	4,813,962,	4,808,186,
4,795,474,	4,795,470,	4,715,859,	4,664,668,	4,662,889,
4,661,112,	4,570,270,	4,344,193	and 3,875,594.	

[0006] The present invention seeks to provide improved joint prostheses which, inter alia, help overcome the above mentioned problems of the prior art.

[0007] The prostheses provide shock absorption, damping and resiliency. Portions of the prostheses which interface with human tissue are preferably constructed of resilient materials which are compatible with human bone or tissue, such as certain types of polyurethane. Certain portions of the prostheses may be constructed of composite materials whose mechanical or physical properties may be optimized, such as to match properties of the local human bone or tissue. By matching properties of the local bone or tissue, the prosthe-

sis behaves mechanically, structurally and thermally in a manner similar to the local bone or tissue, which helps make the prosthesis more efficient and comfortable.

[0008] An important feature of the prostheses is that they help distribute stresses optimally, thereby stimulating regeneration of bone.

[0009] The present invention is applicable for any joint in which there is free movement, known in technical terms as a true diarthrosis. True diarthroses include:

- [0010] 1. Gliding joints, known as arthrodiads, in which the surfaces of the joint are flat, such as in the carpal bones;
- [0011] 2. Hinge joints, known as ginglymi, such as the knee or elbow;
- [0012] 3. Condylod joints, known as condylarthroses, which allow flexion, extension and lateral movement, but no rotation, such as the wrist, and saddle-shaped joints which allow the same type of movement as condylod joints, but are generally stronger, such as the carpo-metacarpal joint of the thumb;
- [0013] 4. Ball and socket joints, known as enarthroses, such as the hip and the shoulder; and
- [0014] 5. Pivot joints, known as trochoides, which only allow rotation, such as the radio-ulnar joints.

[0015] The present invention will be described in detail hereinbelow with respect to a prosthesis for an enarthrosis, such as the hip joint, and to a prosthesis for a ginglymus, such as the knee joint. It is appreciated, however, that a prosthesis for any true diarthrosis is in the scope of the present invention.

[0016] In a radical departure from the prior art, and in accordance with one embodiment of the present invention, a hip joint prosthesis is provided which includes an artificial femoral head which is not fixedly attached to the femur, but rather articulates with both the femur and the acetabulum. The artificial femoral head is generally spherical and may absorb shocks, provide damping and/or be resilient. A separate, artificial femoral head is easier to insert than the prostheses of the prior art which have a stem.

[0017] In addition, the artificial femoral head may be provided with delimiting rails or grooves which serve to define and limit the movement paths of the femur with respect to the body, if required, and dislocation of the joint is substantially prevented. The delimiting rails or grooves may also serve as bumpers which damp and cushion the femoral head at the limits of its articulation.

[0018] The prostheses of the present invention may also be provided with passageways for fluid, such as synovial fluid. Fluid present in these passageways helps to lubricate the prosthesis and provides viscous damping.

[0019] Since the prostheses of the present invention are resilient, they geometrically adapt themselves to changes in static and dynamic forces borne by the joint. In the case of the hip joint prosthesis of the present invention, for example, normal raising of the thigh does not apply substantial forces on the hip joint, and the resilient hip joint prosthesis allows the freedom of movement of a ball and socket joint with substantially no deformation nor obstruction to movement

due to friction between the prosthesis and human tissue or bone, or between adjacent regions of the prosthesis, such as between the artificial femoral head and an artificial socket.

[0020] In contrast, when the person is standing, the static force of the weight of the person on the hip joint causes the resilient prosthesis to deform somewhat, i.e., to be squashed a certain amount. This deformation provides a relatively larger area for supporting the weight on the joint, thereby reducing pressure on the joint. The deformation also increases the friction force between the prosthesis and human tissue or bone, or between adjacent regions of the prosthesis, such as between the artificial femoral head and an artificial socket. The increased friction is beneficial because it does not hinder the stationary person; on the contrary, the increased friction increases stability of the person.

[0021] The resiliency of the prosthesis is also beneficial during sudden slips or falls. The dynamic and/or static forces due to the sudden movement tend to deform or squash the resilient prosthesis. As described above, the deformation reduces pressure on the joint, reduces danger of the prosthesis detaching from the bone, and increases friction which helps provide stability during the slip or fall.

[0022] There is thus provided in accordance with a preferred embodiment of the present invention, a joint prosthesis including at least a first and a second load carrying member, the first load carrying member being substantially more shock absorbing and resilient than the second load carrying member.

[0023] In accordance with a preferred embodiment of the present invention, at least one of the load carrying members is characterized in having at least one of strength and elasticity generally similar to that of human cartilage.

[0024] There is also provided in accordance with a preferred embodiment of the present invention, a joint prosthesis including a plurality of alternating adjacent portions of substantially rigid and substantially resilient materials.

[0025] There is also provided in accordance with a preferred embodiment of the present invention, a joint prosthesis including a plurality of alternating adjacent first and second portions, the first portion having a substantially rigid configuration and the second portion having a substantially resilient configuration.

[0026] Preferably at least one of the first and the second portions is generally omega shaped. The joint prosthesis may include at least one portion compatible with human tissue. The joint prosthesis may have at least one hollow portion.

[0027] Preferably, any of the joint prostheses includes at least one delimiting rail or groove.

[0028] Preferably, any of the joint prostheses includes at least one passageway for a fluid.

[0029] There is also provided in accordance with a preferred embodiment of the present invention, a hip joint prosthesis including an artificial, spherical femoral head which is adapted to articulate with an acetabulum and an upper portion of a thigh.

[0030] There is also provided in accordance with a preferred embodiment of the present invention, a hip joint prosthesis including an artificial, self-articulating femoral

head, the head being attachable to at least one of an acetabulum and an upper portion of a thigh.

[0031] Preferably, the hip joint prosthesis includes an artificial femoral head which is shock absorbing, provides damping and/or is substantially resilient.

[0032] Preferably, the femoral head has at least one hollow portion.

[0033] Further in accordance with a preferred embodiment of the present invention, the hip joint prosthesis also includes an artificial acetabulum attachable to an innominate bone, the artificial femoral head articulating with the artificial acetabulum.

[0034] Still further in accordance with a preferred embodiment of the present invention, the hip joint prosthesis also includes an artificial femoral socket attachable to a femur, the artificial femoral head articulating with the artificial femoral socket.

[0035] Further in accordance with a preferred embodiment of the present invention, the artificial femoral head includes a device for substantially preventing dislocation of the artificial femoral head from the artificial acetabulum, the artificial femoral socket, or both.

[0036] Preferably the device for substantially preventing dislocation is shock absorbing or resilient.

[0037] Further in accordance with a preferred embodiment of the present invention, the artificial femoral head includes at least one delimiting rail or groove. The delimiting groove may have a different geometrical shape than that of the rail. This permits providing various predetermined ranges and paths of motion.

[0038] Still further in accordance with a preferred embodiment of the present invention, the artificial femoral head has at least one passageway for a fluid.

[0039] Additionally in accordance with a preferred embodiment of the present invention, the hip joint prosthesis includes a sleeve which envelops at least one portion of the prosthesis and which is attachable to at least one of a portion of an innominate bone and a thigh. Preferably the sleeve includes a relatively high strength fabric.

[0040] Further in accordance with a preferred embodiment of the present invention, the artificial femoral socket is adapted to fit substantially snugly with at least one upper portion of a femur.

[0041] Still further in accordance with a preferred embodiment of the present invention, the artificial femoral head includes a plurality of alternating adjacent portions of substantially rigid and substantially resilient materials.

[0042] Additionally in accordance with a preferred embodiment of the present invention, the hip joint prosthesis further includes a stem insertable into a femur.

[0043] Further in accordance with a preferred embodiment of the present invention, the hip joint prosthesis includes an outer layer attachable to a femur, the outer layer including a material compatible with human tissue.

[0044] There is also provided in accordance with a preferred embodiment of the present invention, a knee joint prosthesis including a femoral portion and a tibial portion,

the femoral portion being attachable to a femur and the tibial portion being attachable to a tibia, the femoral portion articulating with the tibial portion, wherein at least one of the femoral portion and the tibial portion is shock absorbing, provides damping or is substantially resilient.

[0045] In accordance with a preferred embodiment of the present invention, the knee joint prosthesis includes a device operative to limit motion of the tibia with respect to the femur.

[0046] Preferably, the device operative to limit motion of the tibia with respect to the femur, is shock absorbing.

[0047] Additionally in accordance with a preferred embodiment of the present invention, the femoral portion is generally convex and the tibial portion is generally concave.

[0048] Alternatively in accordance with a preferred embodiment of the present invention, the femoral portion is generally convex and the tibial portion is generally convex.

[0049] Further in accordance with a preferred embodiment of the present invention, the knee joint prosthesis includes at least one roller element, the femoral portion articulating with the tibial portion via the at least one roller element.

[0050] Preferably, the knee joint prosthesis has at least one fluid passageway.

[0051] There is also provided in accordance with a preferred embodiment of the present invention, a bone fastener including a plurality of alternating adjacent portions of substantially rigid and substantially resilient materials.

[0052] There is also provided in accordance with a preferred embodiment of the present invention, a bone fastener including a plurality of alternating adjacent first and second portions, the first portion having a substantially rigid configuration and the second portion having a substantially resilient configuration.

[0053] There is also provided in accordance with a preferred embodiment of the present invention, a method of incision of a ligament including forming a substantially wave-like incision in the ligament.

[0054] There is also provided in accordance with a preferred embodiment of the present invention, a method of insertion of a hip joint prosthesis including:

[0055] fixedly attaching a first joint element to an upper portion of a femur, the first joint element fitting substantially snugly with the upper portion of the femur;

[0056] fixedly attaching a second joint element to a portion of an innominate bone; and

[0057] inserting an artificial femoral head intermediate the first and the second joint elements, such that the artificial femoral head articulates with at least one of the first and the second joint elements.

[0058] Preferably, one or more natural or artificial ligaments may be used to strengthen the hip joint.

[0059] There is also provided in accordance with a preferred embodiment of the present invention, a method for limiting a range of movement of a hip joint including:

[0060] implanting a hip joint prosthesis comprising at least one delimiting rail and at least one delimiting groove, the at least one delimiting rail articulating with the at least one delimiting groove, such that the at least one delimiting groove limits articulation of the at least one delimiting rail therein.

[0061] The present invention will be understood and appreciated from the following detailed description, taken in conjunction with the drawings in which:

[0062] FIG. 1 is a simplified illustration of a human hip joint;

[0063] FIG. 2 is a simplified illustration of a hip joint prosthesis, constructed and operative in accordance with a preferred embodiment of the present invention;

[0064] FIG. 3 is a partially sectional illustration of the hip joint prosthesis of FIG. 2;

[0065] FIG. 4 is a partially sectional illustration of the hip joint prosthesis of FIG. 2, wherein the femur is rotated laterally;

[0066] FIG. 5 is a partially sectional illustration of the hip joint prosthesis of FIG. 2, wherein the femur is rotated rearwardly;

[0067] FIG. 6 is a simplified pictorial illustration of an artificial femoral head of the hip joint prosthesis of FIG. 2, the femoral head comprising two delimiting rails;

[0068] FIGS. 7A and 7B are simplified illustrations of an artificial femoral head, constructed and operative in accordance with another preferred embodiment of the present invention, articulating with artificial and natural acetabula respectively, and wherein the artificial femoral head has no delimiting rails;

[0069] FIGS. 8A and 8B are simplified illustrations of an artificial femoral head fixedly attached to a stem, constructed and operative in accordance with yet another preferred embodiment of the present invention, articulating with artificial and natural acetabula respectively, and wherein the artificial femoral head has no delimiting rails;

[0070] FIG. 8C is a simplified illustration of an artificial, self-articulating femoral head fixedly attached to a stem and to an acetabulum, constructed and operative in accordance with a preferred embodiment of the present invention;

[0071] FIG. 9A is a simplified pictorial illustration of an artificial femoral head and an artificial acetabulum, constructed and operative in accordance with still another preferred embodiment of the present invention, and wherein the artificial femoral head has one delimiting rail which articulates with the generally elliptically shaped acetabulum;

[0072] FIG. 9B is a simplified sectional illustration of the femoral head of FIG. 9A, taken along lines 9B-9B in FIG. 9A;

[0073] FIG. 9C is a simplified pictorial illustration of a flexible and stable bone connector, constructed and operative in accordance with a preferred embodiment of the present invention;

[0074] FIGS. 9D and 9E are simplified, sectional illustrations of a flexible and stable bone connector stem of a hip joint prosthesis, constructed and operative in accordance

with a preferred embodiment of the present invention, before and after deployment, respectively;

[0075] **FIGS. 9F and 9G** are simplified, sectional illustrations of a flexible and stable bone connector stem of a hip joint prosthesis, constructed and operative in accordance with another preferred embodiment of the present invention, before and after deployment, respectively;

[0076] **FIG. 10** is a simplified sectional illustration of a non-hollow artificial femoral head, constructed and operative in accordance with a preferred embodiment of the present invention;

[0077] **FIG. 11** is a simplified sectional illustration of an artificial femoral head, constructed and operative in accordance with another preferred embodiment of the present invention, and wherein the femoral head comprises a plurality of hollow portions;

[0078] **FIG. 12** is a simplified sectional illustration of an artificial femoral head, constructed and operative in accordance with yet another preferred embodiment of the present invention, and wherein the femoral head comprises a plurality of hollow portions filled with a fluid;

[0079] **FIG. 13** is a simplified sectional illustration of an artificial femoral head, constructed and operative in accordance with still another preferred embodiment of the present invention, and wherein the femoral head comprises a plurality of portions, each portion not necessarily having the same mechanical or physical properties;

[0080] **FIG. 14A** is a simplified sectional illustration of an artificial femoral head, constructed and operative in accordance with another preferred embodiment of the present invention, and wherein the femoral head comprises a protruding delimiting bumper;

[0081] **FIG. 14B** is a simplified sectional illustration of an artificial femoral head, constructed and operative in accordance with yet another preferred embodiment of the present invention, and wherein the femoral head comprises a thin, resilient outer shell and a resilient core;

[0082] **FIG. 15** is a simplified pictorial illustration of an artificial femoral head, constructed and operative in accordance with a preferred embodiment of the present invention, and including delimiting grooves;

[0083] **FIG. 16** is a simplified sectional illustration of an artificial femoral head, constructed and operative in accordance with another preferred embodiment of the present invention, and wherein the femoral head has fluid passageways;

[0084] **FIG. 17** is a simplified sectional illustration of an artificial femoral head, constructed and operative in accordance with yet another preferred embodiment of the present invention;

[0085] **FIGS. 18A and 18B** are simplified pictorial and sectional illustrations respectively of an artificial femoral head, constructed and operative in accordance with another preferred embodiment of the present invention, and wherein the femoral head comprises a plurality of alternating adjacent portions of substantially rigid and substantially resilient materials, **FIG. 18B** being taken along lines **18B-18B** in **FIG. 18A**;

[0086] **FIGS. 18C-18 F** are simplified pictorial illustrations of alternative constructions of a femoral head including a plurality of alternating adjacent portions of substantially rigid and substantially resilient materials;

[0087] **FIG. 18G** is a simplified pictorial illustration of an artificial acetabulum, constructed and operative in accordance with a preferred embodiment of the present invention;

[0088] **FIGS. 18H, 18I and 18J** are simplified illustrations of installing the artificial acetabulum of **FIG. 18G** into a natural acetabulum, in accordance with a preferred embodiment of the present invention;

[0089] **FIGS. 18K and 18L** are simplified sectional illustrations of two artificial acetabula, constructed and operative in accordance with two preferred embodiments of the present invention;

[0090] **FIGS. 19A-19C** are simplified pictorial illustrations of a method of incision of ligaments, such as prior to insertion of a hip joint prosthesis, in accordance with a preferred embodiment of the present invention;

[0091] **FIG. 20** is a simplified pictorial illustration of a sleeve for joining a femoral head with the innominate bone, constructed and operative in accordance with a preferred embodiment of the present invention;

[0092] **FIG. 21** is a simplified sectional illustration of an expandable artificial femoral head, constructed and operative in accordance with a preferred embodiment of the present invention;

[0093] **FIG. 22** is a simplified illustration of a human knee joint;

[0094] **FIGS. 23 and 24** are respective simplified side and front view illustrations of a knee joint prosthesis, constructed and operative in accordance with a preferred embodiment of the present invention;

[0095] **FIG. 25** is a simplified illustration of a femoral portion of the knee joint prosthesis of **FIGS. 23 and 24**;

[0096] **FIG. 26** is a simplified illustration of a tibial portion of the knee joint prosthesis of **FIGS. 23 and 24**;

[0097] **FIGS. 27 and 28** are respective simplified side and front view illustrations of a knee joint prosthesis, constructed and operative in accordance with another preferred embodiment of the present invention;

[0098] **FIGS. 29 and 30** are respective simplified side and front view illustrations of a knee joint prosthesis, constructed and operative in accordance with yet another preferred embodiment of the present invention;

[0099] **FIGS. 31 and 32** are respective simplified side and front view illustrations of a knee joint prosthesis, constructed and operative in accordance with still another preferred embodiment of the present invention;

[0100] **FIG. 33** is a simplified illustration of a roller element included in the knee joint prosthesis of **FIGS. 31 and 32**;

[0101] **FIG. 34** is a simplified, partially sectional illustration of a bone fastener, constructed and operative in accordance with a preferred embodiment of the present invention; and

[0102] FIG. 35 is a simplified, partially sectional illustration of a vertebra replacement, constructed and operative in accordance with a preferred embodiment of the present invention.

[0103] The present invention will now be described in detail with respect to a prosthesis for an enarthrosis, an example being the hip joint, and to a prosthesis for a ginglymus, an example being the knee joint. It is appreciated, however, that a prosthesis for any true diarthrosis is in the scope of the present invention.

[0104] For a better understanding of a hip joint prosthesis, a basic description of the human hip joint is presented here with reference to FIG. 1, which illustrates the hip of the right side of the body. The hip joint is a ball and socket joint, the ball being the femoral head (head of the thigh bone) which articulates with the acetabulum of the innominate bone, known in non-technical terms as the socket of the hip bone.

[0105] The innominate bone in the area of the hip joint is made of three portions: the upper portion is called the ilium, the middle portion is called the pubis and the lower portion is called the ischium. The femoral head is connected to the innominate bone by a plurality of ligaments. The ligaments shown in FIG. 1 are the ilio-femoral ligaments and the pubo-femoral ligament. There is also an ischio-femoral ligament, not seen in FIG. 1. The femoral head articulates with a fibrous rim of the acetabulum called the cotyloid ligament.

[0106] Generally a hip joint replacement of the prior art involves replacing the natural femoral head with a metallic artificial femoral head which is fixedly attached to a stem. The stem is generally inserted in the femur and the femoral head articulates with the acetabulum, if still intact, or some other depression, artificial or natural, in the innominate bone. Some or all of the ilio-femoral, pubo-femoral and ischio-femoral ligaments may be removed to provide access to the femoral head and acetabulum.

[0107] Reference is now made to FIGS. 2 and 3 which illustrate a hip joint prosthesis 10, constructed and operative in accordance with a preferred embodiment of the present invention. In a radical departure from the prior art, hip joint prosthesis 10 comprises a femoral head 12 which is not fixedly attached to the femur, but rather is capable of articulating with both the thigh and the innominate bone. In accordance with a preferred embodiment of the present invention, femoral head 12 may be constructed of a rigid material compatible with human tissue, for example, a metal such as stainless steel, or a structural plastic.

[0108] In accordance with another preferred embodiment of the present invention, artificial femoral head 12 is constructed of a material which is shock absorbing, and additionally or alternatively provides damping, and additionally or alternatively is resilient. An example of such a material is polyurethane or synthetic rubber.

[0109] A resilient artificial femoral head, unlike the prior art, yields upon application of forces and substantially returns to its original shape after such forces are removed.

[0110] Artificial femoral head 12 is preferably, although not necessarily, generally spherical in shape. In accordance with a preferred embodiment of the present invention, and as

shown in FIG. 3, femoral head 12 has a hollow core 14. Hollow core 14, inter alia, adds to the resiliency and shock absorbing characteristics of femoral head 12.

[0111] In accordance with a preferred embodiment of the present invention, hip joint prosthesis 10 also comprises an artificial acetabulum 16 which is preferably fixedly attached to the innominate bone via an acetabulum interface 18. Artificial femoral head 12 articulates with artificial acetabulum 16.

[0112] Additionally in accordance with a preferred embodiment of the present invention, hip joint prosthesis 10 comprises an artificial femoral socket 20 which is preferably fixedly attached to the femur via a stem 22. Alternatively, socket 20 may be attached to the femur without a stem, for example, by bonding. Artificial femoral head 12 articulates with artificial femoral socket 20. Socket 20 is shaped to facilitate this articulation, such as being generally concave. In addition, socket 20 is preferably shaped to overlap, or snugly fit, the upper portion of the natural femur. The generally concave, overlapping shape of artificial femoral socket 20 helps distribute stresses optimally on the femur, thereby stimulating regeneration of bone.

[0113] Socket 20 may overlap and "hug" the upper portion of the femur on the outside surface of the femur. Alternatively or additionally, socket 20 may be configured to fit snugly into an inner surface of the femur.

[0114] It is important to note that socket 20 serves two general tasks, as described above. The first task is articulation with artificial femoral head 12. The second task is fitting snugly with the femur and distributing stresses evenly thereon.

[0115] It is appreciated that in accordance with another preferred embodiment of the present invention, socket 20 may comprise two separate portions each generally dedicated to serving one of the above described tasks. A first portion 20A, generally concave in shape, may be generally dedicated to articulation with artificial femoral head 12. A second portion 20B, generally shaped as a "crown" to hug and snugly fit circumferentially around and on top of the femur, may be generally dedicated to distributing stresses evenly on the femur. This is true of any of the sockets described herein with reference to any of the embodiments of the present invention. The "crown", i.e., second portion 20B, greatly changes the loading conditions of prosthesis 10, decreases stresses exerted on the femur by stem 22, and creates a new and healthier stress distribution on the surrounding bone and tissue. With the support of second portion 20B, stem 22 may have a much smaller section throughout and particularly at its neck.

[0116] Stem 22 preferably includes a core 24 and an outer layer 26, as seen in FIGS. 2 and 3. Outer layer 26 preferably includes one or more ridges 28, which, inter alia, help distribute stresses and help fasten stem 22 to the femur.

[0117] Core 24 of stem 22, artificial acetabulum 16 and artificial femoral socket 20 are preferably constructed of a rigid material, for example, stainless steel or a structural plastic. Alternatively, the rigid material may be a composite material, such as a lay-up of graphite fibers, which may be constructed to have mechanical or physical properties, such as modulus of elasticity or coefficient of thermal expansion, equivalent to that of the local human bone.

[0118] Stem 22 provides excellent three-dimensional anchorage to the bone, and induces three-dimensional loading stress conditions as close as possible to the natural conditions. The improved stress field distribution at the interface between the prosthesis and the bone helps prevent lysis. The stress field set up by the prosthesis inside the bone helps induce regeneration and strengthening of the bone.

[0119] Acetabulum interface 18 and outer layer 26 of stem 22 are preferably made of a resilient material compatible with human tissue, such as polyurethane, which helps distribute stresses optimally, thereby stimulating regeneration of bone. In accordance with a preferred embodiment of the present invention, acetabulum interface 18 and outer layer 26 of stem 22 are constructed of a material, such as polyurethane, which has one or more mechanical and/or physical properties substantially similar to human cartilage.

[0120] Hip joint prosthesis 10 may include a device for facilitating removal as is known in the art, such as a threaded boss or hole (both not shown).

[0121] It may sometimes be desired to limit the number of degrees of freedom of the hip joint or the range of a particular degree of freedom of movement of the femur with respect to the acetabulum, depending on the needs of the patient. It may also be desired to provide safeguards to substantially prevent dislocation of the joint. In accordance with a preferred embodiment of the present invention, apparatus is provided to achieve these goals, as is now described.

[0122] Reference is now made additionally to FIGS. 4-6. In accordance with a preferred embodiment of the present invention, artificial femoral head 12 is provided with an upper delimiting rail 30 and a lower delimiting rail 32. Upper delimiting rail 30 slides in a channel 34 in artificial acetabulum 16. Channel 34 is oriented generally forwards and rearwards with respect to the human body. As seen in FIG. 5, upper delimiting rail 30 slides forwards in channel 34 when the femur is moved backwards. It is appreciated that upper delimiting rail 30 slides backwards in channel 34 when the femur is moved forwards.

[0123] Lower rail 32 slides in a channel 36 in artificial femoral socket 20. As seen in FIG. 4, as the femur is moved laterally away from the body, lower rail 32 slides in channel 36 of socket 20 and butts thereagainst. Upper delimiting rail 30 is similarly constrained to slide in channel 34. Constraining the travel of rails 30 and 32 in channels 34 and 36, respectively, substantially prevents overtravel of the femur and substantially prevents dislocation of artificial femoral head 12 from artificial acetabulum 16 and artificial femoral socket 20. Moreover, since femoral head 12 is preferably constructed of a shock absorbing or resilient material, the butting of rails 30 and 32 against channels 34 and 36, respectively, is substantially cushioned and damped.

[0124] Variations of hip joint prosthesis 10 are possible within the scope of the present invention. Reference is now made to FIGS. 7A and 7B which illustrate an artificial femoral head 40, constructed and operative in accordance with another preferred embodiment of the present invention. Artificial femoral head 40 may be similar in construction and operation to artificial femoral head 12 of FIGS. 2-6. Femoral head 40 differs from femoral head 12 in that femoral head 40 has no delimiting rails. In FIG. 7A, femoral

head 40 is shown articulating with an artificial acetabulum 42. In FIG. 7B, femoral head 40 is shown articulating with a natural acetabulum 44.

[0125] Reference is now made to FIGS. 8A and 8B which illustrate an artificial femoral head 46 fixedly attached to a crown 48, constructed and operative in accordance with yet another preferred embodiment of the present invention. Femoral head 46 and crown 48 may be constructed of a resilient material, such as polyurethane.

[0126] Crown 48 may be attached to an upper portion of the thigh. Alternatively, as shown in FIG. 8A, crown 48 may be attached to a stem 49. Stem 49 may include a core 49A and an outer layer 49B. Core 49A may be of solid construction, and additionally or alternatively, may include at least one hollow portion. Outer layer 49B may be constructed of a material with properties similar to human cartilage.

[0127] In FIG. 8A, femoral head 46 articulates with an artificial acetabulum 50. Femoral head 46 may have an upper delimiting rail (not shown) which articulates with a corresponding groove (not shown) in artificial acetabulum 50. Alternatively, femoral head 46 may have a delimiting groove with which articulates a corresponding rail in artificial acetabulum 50.

[0128] In FIG. 8B, femoral head 46 articulates with a natural acetabulum 52. Femoral head 46 may include a hollow portion (not shown), as described hereinabove for artificial femoral head 12 with respect to FIGS. 2-6.

[0129] Alternatively, in accordance with another preferred embodiment of the present invention, artificial femoral head 46 may be fixedly attached to artificial acetabulum 50. In such an embodiment, artificial femoral head 46 may articulate with crown 48.

[0130] Reference is now made to FIG. 8c which illustrates an artificial, self-articulating femoral head 55 fixedly attached to a stem 56 and to an artificial acetabulum 57, constructed and operative in accordance with a preferred embodiment of the present invention. Femoral head 55 is preferably constructed of a resilient material, such as polyurethane. Artificial acetabulum 57 may have any suitable shape, typically being generally shell-shaped or spherical.

[0131] Articulation of the thigh with the innominate bone is not achieved by articulation of femoral head 55 with artificial acetabulum 57, but rather is achieved by the self-articulation of femoral head 55. "Self-articulation" is defined as the ability of femoral head 55 to permit rotary and translatory motion of the thigh with respect to the innominate bone due to the resilient and elastic properties and configuration of femoral head 55. Stem 56 may comprise an outer layer 58 which may have properties similar to human cartilage.

[0132] Reference is now made to FIGS. 9A and 9B which illustrate an artificial femoral head 60 and an artificial acetabulum 62, constructed and operative in accordance with still another preferred embodiment of the present invention. Artificial femoral head 60 has one delimiting rail 64 which articulates with a generally elliptically shaped recess 66 in artificial acetabulum 62. It is appreciated that this type of rail may be employed in any of the other artificial femoral heads described herein, either as an upper rail or a lower rail or both.

[0133] Artificial femoral head **60** may be provided with one or more fluid passageways **67**, as seen in **FIG. 9A**, for flow therethrough of a fluid (not shown), such as synovial fluid. It is appreciated that any of the artificial femoral heads of the present invention may be provided with fluid passageways. Fluid passageways **67** help lubricate artificial femoral head **60**, and provide damping.

[0134] Reference is now made to **FIG. 9C** which illustrates a flexible and stable bone connector **450**, constructed and operative in accordance with a preferred embodiment of the present invention. Connector **450** preferably includes a hollow, generally tubular portion **452** and a bone interface portion **454**. Interface portion **454** is preferably shaped to snugly fit the inner geometry of the bone into which it is placed. The inner geometry of the bone may be determined by such methods as a computer tomography, and interface portion **454** may then be machined accordingly.

[0135] In accordance with a preferred embodiment of the present invention, interface portion **454** has a fluted shape with a plurality of protruding fins **456**. The fluted shape of interface portion **454** and the hollowness of tubular portion **452** promote bone development and growth after implanting the prosthesis. Connector **450** may be fashioned in a variety of configurations, such as straight, curved, cylindrical or tapered, for example.

[0136] A known problem associated with the repair of broken bones and with the insertion of stems of femoral prostheses into femurs, is that the bone may have a curvature which changes along the length thereof in three dimensions. It is difficult to match the curvature of the stem of the prosthesis to the natural curvature of the bone. In practice, usually a set of standardized connecting pins or prostheses are used and the closest matching prosthesis is selected and further machined or filed in the operating theater to match the measured natural curvature of the femur. Even with this method, gaps are almost inevitable between the prosthesis and the inner bone tissue.

[0137] It is a particular feature of the present invention that connector **450** is sufficiently flexible so that it can be inserted into a bored portion of the bone, such as a femur, and deform to adapt to the changing curvature of the bone, thereby helping to solve the aforementioned problem. Connector **450** is preferably constructed of a material which provides flexibility to permit insertion into the bone, while at the same time providing sufficient structural stability once connector **450** is in place. A suitable material is one having a non-linear, "half-bell-shaped" stress-strain relationship, for example, a plastic such as polyurethane. The material may be reinforced with fibers, whose density and orientation may be selected in accordance with a particular engineering requirement.

[0138] Reference is now made to **FIGS. 9D and 9E** which illustrate a flexible and stable bone connector stem **460** of a hip joint prosthesis, constructed and operative in accordance with a preferred embodiment of the present invention. Stem **460** may be readily employed in any of the femoral prostheses of the present invention.

[0139] Stem **460** is preferably constructed similarly to connector **450**, and preferably includes a fluted elongated portion **462** having a hollow portion **464** and a plurality of protruding fins **466**. A force transfer element **468**, such as a

wire, rod or cable, with a plurality of bulges **470** is preferably disposed in hollow portion **464**. Element **468** may be made of any suitable stiff, biocompatible material, such as DYNEMA.

[0140] Stem **460** is preferably inserted into the femur in the orientation shown in **FIG. 9D**. After insertion, element **468** is then moved generally in the direction of an arrow **472**, thereby causing bulges **470** to deform fluted portion **462**, as seen in **FIG. 9D**, and fix stem **460** firmly in the femur.

[0141] Reference is now made to **FIGS. 9F and 9G** which illustrate a flexible and stable bone connector stem **480** of a hip joint prosthesis, constructed and operative in accordance with another preferred embodiment of the present invention. Stem **480** may also be readily employed in any of the femoral prostheses of the present invention.

[0142] Stem **480** preferably includes a fluted elongated portion **482** in which is disposed a sleeve **484** having a plurality of bulges **486**. Disposed inside sleeve **484** is hollow shaft **488**. Sleeve **484** is arranged for sliding, axial motion with respect to fluted portion **482** and shaft **488**.

[0143] As describe hereinabove for fluted portion **462**, fluted portion **482** is sufficiently flexible so that it can be inserted into a bored portion of a femur and deform to adapt to the changing curvature of the femur.

[0144] Stem **480** is preferably inserted into the femur in the orientation shown in **FIG. 9F**. After insertion, sleeve **484** is then moved generally in the direction of an arrow **490**, thereby causing bulges **486** to deform fluted portion **482**, as seen in **FIG. 9D**, and fix stem **480** firmly in the femur.

[0145] Artificial femoral head **12** shown in **FIGS. 2-6**, has a hollow core **14**. Reference is now made to **FIG. 10** which illustrates a non-hollow artificial femoral head **70**, constructed and operative in accordance with a preferred embodiment of the present invention. Artificial femoral head **70** may include an upper rail **72** and a lower rail **74**.

[0146] Reference is now made to **FIG. 11** which illustrates an artificial femoral head **80**, constructed and operative in accordance with another preferred embodiment of the present invention. Femoral head **80** comprises a plurality of hollow portions **82**.

[0147] Reference is now made to **FIG. 12** which illustrates an artificial femoral head **90**, constructed and operative in accordance with yet another preferred embodiment of the present invention. Femoral head **90** comprises a plurality of hollow portions **92** filled with a fluid, such as synovial fluid. Additionally or alternatively, one or more fluid passageways **94** may be provided. The fluid in portions **92** or passageways **94** may enhance the shock absorbing and damping characteristics of femoral head **90**.

[0148] Reference is now made to **FIG. 13** which illustrates an artificial femoral head **100**, constructed and operative in accordance with still another preferred embodiment of the present invention. Femoral head **100** comprises a plurality of portions **102**, each portion **102** not necessarily having the same mechanical or physical properties. Portions **102** may be used to enhance, to optimize or to customize the shock absorbing and damping characteristics of femoral head **100**.

[0149] Reference is now made to **FIG. 14A** which illustrates an artificial femoral head **110**, constructed and opera-

tive in accordance with another preferred embodiment of the present invention. Femoral head **110** comprises a protruding delimiting bumper **112** instead of a delimiting rail.

[0150] Reference is now made to **FIG. 14B** which illustrates an artificial femoral head **113**, constructed and operative in accordance with yet another preferred embodiment of the present invention. Femoral head **113** comprises a thin, resilient outer shell **114** and a resilient core **115**. Shell **114** may be constructed of DYNEEMA high performance polyethylene fibers, commercially available from DSM, Netherlands. DYNEEMA, particularly in the form of a woven fabric, provides a combination of high strength with excellent shock absorbing and damping characteristics, as well as being biocompatible. Core **115** may also be made of DYNEEMA with properties engineered to meet requirements such as strength or resilience, for example, and may be impregnated with other materials, such as a resin.

[0151] Reference is now made to **FIG. 15** which illustrates an artificial femoral head **120**, constructed and operative in accordance with a preferred embodiment of the present invention. Femoral head **120** includes delimiting grooves **122** which articulate with corresponding rails (not shown) in an artificial acetabulum and an artificial socket (not shown).

[0152] Reference is now made to **FIG. 16** which illustrates an artificial femoral head **130**, constructed and operative in accordance with another preferred embodiment of the present invention. Femoral head **130** has fluid passageways **132** which allow flow therethrough of a fluid, preferably synovial fluid, the natural lubrication fluid of the human body. Fluid passageways **132** may be configured in a variety of orientations, configurations and sizes. Alternatively or additionally, passageways **132** may be provided in an artificial femoral socket **134** or an artificial acetabulum **136**.

[0153] Fluid flowing in fluid passageways **132** may help lubricate femoral head **130**. The presence of fluid in fluid passageways **132** may also enhance the shock absorbing and damping characteristics of femoral head **130**.

[0154] As mentioned above, the ligaments connecting the femur and the innominate bone may be removed in the prior art, before placement of a hip joint prosthesis. This is unfortunate because these ligaments are amongst the strongest ligaments in the body. These ligaments strengthen the joint and help prevent dislocation. Pre-serving some or all of the ligaments is therefore desirable.

[0155] Reference is now made to **FIG. 17** which illustrates an artificial femoral head **140**, constructed and operative in accordance with yet another preferred embodiment of the present invention. Artificial femoral head **140** is preferably relatively small in size, thereby helping to reduce the need for tampering with some of the hip joint ligaments. In this embodiment, femoral head **140** articulates with an artificial acetabulum **142** and an artificial socket **144**. Socket **144** may be attached directly to the femur without a stem, such as by bonding or via a crown (not shown) similar to the crown-shaped portion **20B** described hereinabove with reference to **FIGS. 2 and 3**.

[0156] By eliminating the stem, the need for tampering with or drilling into the femur may also be eliminated. There may be no need to remove the entire natural femoral head, but rather a portion thereof may be preserved. Preserving

part of the femur may simplify the surgical operation and may preserve most of the strength of the bone.

[0157] The need for tampering with some of the ligaments may also be reduced. Indeed, the intact ligaments themselves act together with the prosthesis of **FIG. 17**, because they tend to keep femoral head **140** properly installed. In addition, the embodiment of **FIG. 17** may be more easily and quickly implanted than prostheses having stems.

[0158] Other embodiments of the present invention which address the problem of preserving the hip joint ligaments are described hereinbelow with respect to **FIGS. 19A-21**.

[0159] Reference is now made to **FIGS. 18A and 18B** which illustrate an artificial femoral head **150**, constructed and operative in accordance with another preferred embodiment of the present invention. Femoral head **150** comprises a plurality of alternating adjacent portions **152** and **154** of substantially rigid and substantially resilient materials respectively. The rigid material is preferably a composite material and the resilient material is preferably polyurethane. In accordance with a preferred embodiment of the present invention, femoral head **150** is attached to an artificial acetabulum **156**.

[0160] The material composition and the geometry of the portions **152** and **154** may be optimized to provide the desired rigidity and resiliency. In this manner, femoral head **150** may be constructed as a non-linear spring with multiple spring constants.

[0161] Femoral head **150** may have different rigidity and resiliency for forward-backward motion as opposed to lateral motion. For example, as seen in **FIG. 18B**, adjacent portions **152** and **154** are generally omega-shaped. Such a shape permits relatively easy swinging of the femur forwards and backwards with respect to the body, while at the same time constraining the swinging range to prevent over-travel of the femur. The resiliency of femoral head **150** damps the motion of the femur at the limits of its swing. The omega shape is stiffer in the lateral direction, thus limiting lateral motion of the femur with respect to the body. It is appreciated that femoral head **150** may be alternatively constructed to allow greater freedom of motion laterally than forwards and backwards.

[0162] Reference is now made to **FIGS. 18C and 18D** which show femoral heads **160** and **162** respectively, with adjacent layers **161** and **163** of substantially rigid and substantially resilient materials, respectively, constructed and operative in accordance with an alternative preferred embodiment of the present invention. As shown in **FIGS. 18E and 18F**, femoral heads **160** and **162** may be provided with apertures **164** and **166** respectively, which may, for example, provide a passageway for synovial fluid, nerves, blood vessels, ligaments, tissues, elongated force transmitting members or prosthetic controls. Fluid in apertures **164** and **166** may enhance the damping of femoral heads **160** and **162** respectively.

[0163] It is appreciated that the embodiments of **FIGS. 18A-18F** may be used as hinge or joint elements in other applications where it is desired to provide different rigidity or resiliency in different directions of motion.

[0164] Reference is now made to **FIG. 18G** which illustrates an artificial acetabulum **400**, constructed and operative in accordance with a preferred embodiment of the present invention.

[0165] Artificial acetabulum 400 preferably includes an interface 402 made of a resilient, cartilage-like material, and preferably has a generally triangular cut-out 404. Acetabulum 400 preferably also includes an outer ridge 406 that “snap-fits” into the natural acetabulum socket, thereby substantially fixing artificial acetabulum 400 in the natural socket. The natural acetabulum may have to be drilled, cut or otherwise machined to ensure a proper snap fit so that acetabulum 400 is rigidly held in place. Ridge 406 may be continuous or may be formed of discrete portions that protrude into the natural acetabulum recesses. As seen in FIG. 18G, interface 402 may comprise a deformable, resilient flange 408 with expandable, accordion-like folds. Interface 402 may be one highly deformable piece, or may be slightly deformable, in which case it may fit into the natural acetabulum with a slight “click”.

[0166] It is a particular feature of the present invention that ridge 406 provides shock absorption and positively locks interface 402 into a recess prepared in the natural socket, without any need for screws or adhesive. Interface 402 may comprise one or more layers. The large surface area of interface 402 provides a large load bearing and shock absorbing surface for a femoral head. Interface 402 may itself serve as an articulating surface for a femoral head, in which case the large surface area diminishes fretting and wearing of the articulating surfaces.

[0167] Reference is now made to FIGS. 18K and 18L which illustrate a cross section of interface 402 constructed in accordance with two preferred embodiments of the present invention. In FIG. 18K, it is seen that interface 402 preferably includes a plurality of protrusions 410 for locking interface 402 in recesses prepared in the natural socket. As seen in FIGS. 18G and 18L, interface 402 may also include an “umbilical” protrusion 412 that is configured to fit the natural or restructured “umbilical” recess of the natural acetabulum. This allows reduction of machining of the innominate bone and leaves a stronger bone.

[0168] Acetabulum 400 also preferably includes a locking piece 414 complementary shaped and sized to snugly fit into triangular cut-out 404. Interface 402 together with locking piece 414 may be used as the articulating portion of the prosthesis with the femur. Additionally, there is preferably provided an articulation portion 416 which snaps together with a recess 418 formed in interface 402. Articulation portion 416 may be made of metal, composite material, cartilage-like material, polyurethane or DYNEEMA. Articulation portion 416 may alternatively be attached to interface 402 by means of a bayonet type of connection or simply a press fit without clicking. Articulation portion 416 makes artificial acetabulum 400 into one stable integral assembly which is easily assembled in and removed from the innominate bone.

[0169] Reference is now made to FIGS. 18H, 18I and 18J which illustrate installing artificial acetabulum 400 into a natural acetabulum, in accordance with a preferred embodiment of the present invention. In FIG. 18H, an insertion tool 420 squeezes triangular cut-out 404 inwardly in the direction of arrows 422, to allow insertion of interface 402 into the natural socket. Upon release of insertion tool 420, cut-out 404 springs outwards much in the manner of a retaining ring, thereby pressing interface 402 firmly against and into the natural socket. Prongs of the insertion tool may be placed in prepared recesses or holes in interface 402.

[0170] In FIG. 18I, locking piece 414 is inserted into cut-out 404, thereby completing the shape of acetabulum 400 and firmly locking interface 402 into the natural socket when an articulating head or an additional articulating surface is assembled therewith. In FIG. 18j, articulation portion 416 is snapped together with interface 402, thereby making artificial acetabulum 400 into one integral assembly.

[0171] As mentioned above, the ligaments connecting the femur and the innominate bone may be removed in the prior art, before placement of a hip joint prosthesis. Methods for preserving the hip joint ligaments, or reinforcing or replacing them, are now described.

[0172] Reference is now made to FIGS. 19A-19C which illustrate a method of incision of ligaments, such as prior to insertion of a hip joint prosthesis, in accordance with a preferred embodiment of the present invention. A primary goal of the method of incision is to preserve the ligaments.

[0173] FIG. 19A illustrates a hip joint 170 prior to incision. As seen in FIG. 19B, a wave-like incision 172 may be made, such as with a laser device, in any or all of the ilio-femoral, pubo-femoral and ischio-femoral ligaments. As seen in FIG. 19C, the cut ligaments allow ample room for placement of a hip joint prosthesis (not shown).

[0174] As is known in the art, ligaments generally contract after incision, impairing mending of the ligament tissue. The wave-like shape of incision 172 permits slightly shifting the ligaments so that there is sufficient contact or overlap of the ligaments even after contraction, thereby helping to promote stitching and mending of the ligament tissue.

[0175] Reference is now made to FIG. 20 which illustrates a sleeve 180 for joining a femoral head 182 with the innominate bone, constructed and operative in accordance with a preferred embodiment of the present invention. Sleeve 180 is preferably made of a high strength woven fabric, such as DYNEEMA, polyethylene, nylon or polyurethane. Sleeve 180 preferably comprises filaments with a high elasticity modulus in the longitudinal direction of the ligaments, along an axis 184, and a circumferential stretching weave along an axis 186, generally perpendicular to axis 184, as seen in FIG. 20.

[0176] Sleeve 180 also preferably includes an anchoring band 188 for attaching sleeve 180 to the innominate bone. Anchoring band 188 may be attached to the innominate bone and sleeve 180 may be attached to the femoral head by any suitable means, such as bonding or with mechanical fasteners. Sleeve 180 may replace or assist the natural ligaments of the hip joint. Sleeve 180 may also help in mending of ligament tissue after surgery. All or portions of sleeve 180 may be constructed of a material, such as material used for dissolving sutures, which eventually dissolves after a predetermined period.

[0177] The present invention also provides a hip joint prosthesis which may substantially reduce the need for tampering with the hip joint ligaments. Reference is now made to FIG. 21 which illustrates an expandable artificial femoral head 190, constructed and operative in accordance with a preferred embodiment of the present invention. Femoral head 190 is preferably constructed of a resilient material, such as polyurethane. When expanded, femoral head 190 has substantially the same shape as femoral head 12, described hereinabove with reference to FIGS. 2 and 3.

[0178] In contrast to the prior art, femoral head **190**, before expansion, may be inserted between the existing ligaments with minimum tampering thereof. Femoral head **190** may then be expanded to the desired shape. Femoral head **190** may be inflated by means of a fluid (not shown) introduced, for example, via a thin needle valve (not shown). Alternatively, femoral head **190** may be expanded by introducing therein components of an expandable foam (not shown), which expand inside femoral head **190**.

[0179] The present invention will now be described in detail with respect to a prosthesis for a ginglymus, namely the knee joint. For a better understanding of a knee joint prosthesis, a basic description of the human knee joint is presented here with reference to **FIG. 22**, which illustrates the knee of the right leg.

[0180] The knee is a hinge comprising the internal and external condyles of the femur which articulate with the upper end of the tibia. The femoral condyles are separated by a deep fossa. The upper end of the tibia comprises two tuberosities, the external of which articulates with the head of the fibula.

[0181] The knee also comprises the trochlea of the femur (not shown in **FIG. 22**) which is located forward and upward of the condyles. The patella slides along the trochlea. The patella is shown pulled down in **FIG. 22** in order to show some of the ligaments and cartilage which connect the femur, tibia, fibula and patella. These ligaments and cartilage include, inter alia, the external lateral ligament which connects the external femoral condyle to the fibula, the internal lateral ligament which connects the internal femoral condyle to the tibia, the ligamentum patellae to which is attached the patella, and the transverse ligament and internal semilunar cartilage which are attached to the head of the tibia. The transverse ligament, internal semilunar cartilage and the anterior crucial ligament are attached to the spine (not shown in **FIG. 22**) of the tibia. The spine is a series of elevations on the head of the tibia opposite the fossa between the femoral condyles.

[0182] Reference is now made to **FIGS. 23 and 24** which illustrate a knee prosthesis **200**, constructed and operative in accordance with a preferred embodiment of the present invention. Knee prosthesis **200** comprises an upper or femoral portion **202** and a lower or tibial portion **204**, as seen in **FIGS. 23 and 24**.

[0183] Referring additionally to **FIG. 25**, it is seen that femoral portion **202** preferably comprises two pads **206** upon which rest the internal and external condyles of the femur, as seen in **FIG. 24**, and a trochlear portion **208** which is intermediate the patella and the trochlea, as seen in **FIG. 23**. Pads **206** articulate with tibial portion **204**. As seen in **FIG. 25**, femoral portion **202** also preferably has a socket **210**, whose function is described hereinbelow with reference to tibial portion **204**.

[0184] Referring additionally to **FIG. 26**, it is seen that tibial portion **204** includes an artificial spine **212** which extends into socket **210**. It is appreciated that when the knee flexes, socket **210** restricts the movement of spine **212** therein. Socket **210** and/or spine **212** are preferably constructed of a shock absorbing or resilient material, such that the movement of spine **212** is cushioned at the limits of travel in socket **210**.

[0185] As seen in **FIG. 23**, spine **212** may extend beyond socket **210** into the fossa of the femur. Tibial portion **204** also preferably has two depressions **214** with which pads **206** may articulate. Tibial portion **204** preferably includes a stem **216** for attachment to the tibia. Tibial portion **204** may have one or more hollow portions **218** to increase shock absorption, damping or resiliency.

[0186] As seen in **FIG. 23**, a tibial cushion **220** may be placed intermediate tibial portion **204** and the head of the tibia, tibial cushion **220** preferably being constructed of a material compatible with human tissue, such as polyurethane. In accordance with a preferred embodiment of the present invention, femoral portion **202** may be constructed of a substantially rigid material, such as a composite material, and tibial portion **204** may be constructed of a substantially resilient material, such as polyurethane.

[0187] In accordance with another preferred embodiment of the present invention, femoral portion **202** may be constructed of a substantially resilient material and tibial portion **204** may be constructed of a substantially rigid material.

[0188] In accordance with yet another preferred embodiment of the present invention, femoral portion **202** may be constructed of a substantially resilient material and tibial portion **204** may be constructed of a substantially resilient material.

[0189] It is appreciated that knee prosthesis **200** is operative to absorb static and dynamic shocks.

[0190] It is a particular feature of the present invention that the resiliency of either femoral portion **202** or tibial portion **204** allows the configuration of the contact surfaces between portions **202** and **204** to change according to physical factors, such as load or motion. For example, when bearing loads directed downwards on the tibia, the contact area between portions **202** and **204** becomes relatively large, thereby increasing stability and decreasing pressure on the tibia. When the knee flexes, the contact area is relatively small, which facilitates motion of the tibia with respect to the femur. Femoral portion **202** and tibial portion **204** have different radii of curvature when not exposed to forces. The radii of curvature approach equality when bearing forces directed downwards on the tibia.

[0191] Reference is now made to **FIGS. 27 and 28** which illustrate a knee prosthesis **230**, constructed and operative in accordance with another preferred embodiment of the present invention. Knee prosthesis **230** comprises an upper or femoral portion **232** and a lower or tibial portion **234**, as seen in **FIGS. 27 and 28**. Tibial portion **234** is substantially identical to tibial portion **204** described hereinabove with reference to **FIGS. 23, 24 and 26**.

[0192] Femoral portion **232** preferably comprises two pads **236** upon which rest the internal and external condyles of the femur, as seen in **FIG. 28**, and a trochlear portion **238** which is intermediate the patella and the trochlea, as seen in **FIG. 27**. Pads **236** articulate with tibial portion **234**. Pads **236** preferably have one or more hollow portions **240**, and may have one or more fluid passageways **242**, for permitting flow therethrough of synovial fluid, thereby providing lubrication and enhancing the shock absorbing and damping characteristics of knee prosthesis **230**.

[0193] Femoral portion **232** articulates with tibial portion **234** of knee prosthesis **230** by sliding along the generally

concave surface of tibial portion **234**. Reference is now made to **FIGS. 29 and 30** which illustrate a knee prosthesis **250**, constructed and operative in accordance with another preferred embodiment of the present invention. Knee prosthesis **250** comprises an upper or femoral portion **252** and a lower or tibial portion **254**, as seen in **FIGS. 29 and 30**. Femoral portion **252** is preferably generally convex and articulates with tibial portion **254** by rolling along the generally convex surface of tibial portion **254**.

[**0194**] As described hereinabove with reference to **FIG. 23**, the resiliency of either femoral portion **252** or tibial portion **254** allows the configuration of the contact surfaces between portions **252** and **254** to change according to physical factors, such as load or motion.

[**0195**] Reference is now made to **FIGS. 31 and 32** which illustrate a knee prosthesis **260**, constructed and operative in accordance with another preferred embodiment of the present invention. Knee prosthesis **260** comprises an upper or femoral portion **262** which articulates with a lower or tibial portion **264** by means of one or more roller elements **266**, as seen in **FIGS. 31 and 32**.

[**0196**] Portions **262** and **264** may be substantially rigid and roller elements **266** may be substantially resilient. Conversely, portions **262** and **264** may be substantially resilient and roller elements **266** may be substantially rigid.

[**0197**] Roller elements **266** may permit articulation of femoral portion **262** with tibial portion **264** by means of rolling, sliding, a combination of rolling and sliding, or rolling combined with a deformation of one or more of roller elements **266**. Roller elements **266** may be formed in any shape which provides such rolling and sliding, such as being generally cylindrical in shape. An alternative shape is shown in **FIG. 33**.

[**0198**] At least one fluid passageway **268** may be provided in each roller element **266** for passage therethrough of a fluid, such as synovial fluid, thereby providing lubrication and enhancing the shock absorbing and damping characteristics of knee joint prosthesis **260**.

[**0199**] Alternatively or additionally, each roller element **266** may have at least one hollow portion. Alternatively or additionally, each roller element **266** may comprise a plurality of portions, each portion not necessarily having the same mechanical or physical properties. These portions may be used to enhance, to optimize or to customize the shock absorbing and damping characteristics of the roller element **266**.

[**0200**] Femoral portion **262** may be attached directly to the femoral condyles. Alternatively, as shown in **FIG. 32**, a femoral pad **270** may be placed intermediate femoral portion **262** and the femoral condyles. Femoral pad **270** may be constructed of a material with properties similar to human cartilage, such as polyurethane.

[**0201**] Reference is now made to **FIG. 34** which illustrates a bone fastener **300** for fastening bone fractures, **3** constructed and operative in accordance with a preferred embodiment of the present invention.

[**0202**] Bone fastener **300** preferably includes a core **302** and an outer layer **304**. Outer layer **304** preferably includes one or more ridges **306**, which, inter alia, help distribute stresses and help fasten bone fastener **300** to a bone. Core

302 may be of solid or hollow construction. Bone fastener **300** may have any suitable cross sectional shape, such as circular or elliptical.

[**0203**] In accordance with a preferred embodiment of the present invention, core **302** is preferably constructed of a rigid material, for example, stainless steel or a structural plastic. Alternatively, the rigid material may be a composite material, such as graphite fibers, which may be constructed to have mechanical or physical properties, such as modulus of elasticity or coefficient of thermal expansion, equivalent to that of the local human bone.

[**0204**] Outer layer **304** is preferably made of a resilient material compatible with human tissue, such as polyurethane, which helps distribute stresses optimally, thereby stimulating regeneration of bone. In accordance with a preferred embodiment of the present invention, outer layer **304** is constructed of a material, such as polyurethane, which has one or more mechanical and/or physical properties substantially similar to human cartilage.

[**0205**] Reference is now made to **FIG. 35** which illustrates a vertebra replacement **310**, constructed and operative in accordance with a preferred embodiment of the present invention.

[**0206**] Vertebra replacement **310** preferably includes at least one inner member **312**, at least one intermediate member **314** and at least one outer member **316**. Inner member **312** is preferably constructed of a substantially resilient material and may have one or more hollow portions **318**. Alternatively, portions **318** may be filled with a fluid, such as synovial fluid. Additionally or alternatively, a fluid passageway (not shown) may be provided for fluid flow therethrough, thereby providing lubrication and enhancing the shock absorbing and damping characteristics of vertebra replacement **310**.

[**0207**] Intermediate portion **314** may be less flexible than inner member **312**, and is preferably constructed of a rigid material, for example, stainless steel or a structural plastic. Alternatively, the rigid material may be a composite material, such as graphite fibers, which may be constructed to have mechanical or physical properties, such as modulus of elasticity or coefficient of thermal expansion, equivalent to that of the local human bone.

[**0208**] Outer members **314** are preferably made of a resilient material compatible with human tissue, such as polyurethane, which helps distribute stresses optimally. In accordance with a preferred embodiment of the present invention, outer members **314** may be constructed of a material, such as polyurethane, which has one or more mechanical and/or physical properties substantially similar to human cartilage.

[**0209**] In accordance with a preferred embodiment of the present invention, geometrical data may be provided, such as by computerized tomography, and be used to prepare and select an optimal prosthesis or bone fastener prior to surgery. Data input, such as from the results of computerized tomography, may be used to match the geometry of the prosthesis or bone fastener to the needs of the patient. Either the prosthesis or the bone, or both, may be shaped, such as by computerized machining, using the geometrical data obtained.

[0210] Alternatively, the geometry of a preformed, standard prosthesis may be used to reshape the bone to match the prosthesis. Alternatively, the geometrical data used to reshape the bone may be used generally to form the prosthesis in real time.

[0211] It is appreciated that various features of the invention which are, for clarity, described in the contexts of separate embodiments may also be provided in combination in a single embodiment. Conversely, various features of the invention which are, for brevity, described in the context of a single embodiment may also be provided separately or in any suitable subcombination.

[0212] It will be appreciated by persons skilled in the art that the present invention is not limited to what has been particularly shown and described hereinabove. Rather, the scope of the present invention is defined only by the claims that follow:

1. A joint prosthesis comprising at least a first and a second load carrying member, said first load carrying member being substantially more shock absorbing and resilient than said second load carrying member.

2. A joint prosthesis according to claim 1 and wherein at least one of said first and said second portions is generally omega shaped.

3. A joint prosthesis according to claim 1 or claim 2 and wherein at least one of said load carrying members is characterized in having at least one of strength and elasticity generally similar to that of human cartilage.

4. A hip joint prosthesis comprising a load carrying, spherical femoral head which is adapted to articulate both with an acetabulum and with an upper portion of a thigh.

5. A hip joint prosthesis comprising an artificial, self-articulating, load carrying femoral head, said head being attachable to at least one of an acetabulum and an upper portion of a thigh.

6. A joint prosthesis according to any of the preceding claims and wherein at least one of said load carrying members comprises at least one delimiting rail adapted for moving in a corresponding delimiter groove for controlling movement of said prosthesis.

7. A joint prosthesis according to any of the preceding claims and wherein at least one of said load carrying members has at least one delimiting groove and said prosthesis comprises at least one delimiter rail adapted for moving in said groove for controlling movement of said prosthesis.

8. A hip joint prosthesis comprising an artificial femoral head which articulates with either of an artificial acetabulum and an artificial femoral socket, wherein said artificial femoral head comprises a device for substantially preventing dislocation of said artificial femoral head from either of said artificial acetabulum and said artificial femoral socket.

9. A hip joint prosthesis according to claim 8 and wherein said device for substantially preventing dislocation is shock absorbing.

10. A hip joint prosthesis according to either of claims 8 and 9 and wherein said femoral head has at least one passageway for a fluid.

11. A hip joint prosthesis according to any of claims 8-10 and comprising a sleeve which envelops at least one portion of said prosthesis and which is attachable to at least one of a portion of an innominate bone and a thigh.

12. A hip joint prosthesis according to claim 11 and wherein said sleeve comprises a fabric.

13. A hip joint prosthesis according to claim 12 wherein said fabric comprises a material selected from the group consisting of DYNEEMA, polyethylene, nylon and polyurethane.

14. A hip joint prosthesis according to any of claims 8-13 and wherein said femoral head comprises a plurality of alternating adjacent portions of substantially rigid and substantially resilient materials.

15. A hip joint prosthesis according to any of claims 8-14 and further comprising a stem insertable into a femur.

16. A hip joint prosthesis according to any of claims 8-15 and comprising an outer layer attachable to a femur, said outer layer comprising a material compatible with human tissue.

17. A joint prosthesis comprising at least a first and a second load carrying member, wherein said at least first and second load carrying members are snap fit to each other.

18. A joint prosthesis comprising at least a first load carrying member, wherein said at least first load carrying member is snap fit to at least one of a natural or artificially formed socket in at least one natural or artificial bone element.

19. A crown-shaped prosthesis comprising an element which is configured to hug and snugly fit circumferentially around and on top of a bone and is operative to distribute stresses evenly on said bone.

20. A bone connector comprising an elongate member which is sufficiently flexible to be insertable into a bored portion of a bone and deform to adapt to a changing curvature of said bone, and is structurally stable after being fixed to said bone.

21. An artificial acetabulum comprising a shock absorbing and resilient interface having a cut-out portion and a ridge, said ridge being pressingly fit into a recess of an innominate bone.

22. An artificial acetabulum according to claim 21 and comprising a deformable, resilient flange with expandable, accordion-like folds.

23. An artificial acetabulum according to either of claims 21 and 22 and wherein said interface includes a load bearing and shock absorbing surface for a femoral head.

24. An artificial acetabulum according to any of claims 21-23 and comprising a locking piece complementary shaped and sized to snugly fit into said cut-out.

25. An artificial acetabulum according to any of claims 21-24 and further comprising an articulation portion which snaps together with a recess formed in said interface.

26. A knee joint prosthesis comprising a femoral portion and a tibial portion, said femoral portion being attachable to a femur and said tibial portion being attachable to a tibia, said femoral portion articulating with said tibial portion, wherein at least one of said femoral portion and said tibial portion is load carrying and shock absorbing.

27. A knee joint prosthesis according to claim 26 and comprising a device operative to limit motion of the tibia with respect to the femur.

28. A knee joint prosthesis according to claim 27 and wherein said device operative to limit motion of the tibia with respect to the femur is shock absorbing.

29. A knee joint prosthesis according to any of claims **26-28** and wherein said femoral portion is generally convex and said tibial portion is generally concave, as viewed looking upwards from the tibia.

30. A knee joint prosthesis according to any of claims **26-28** and wherein said femoral portion is generally convex and said tibial portion is generally concave, as viewed looking upwards from the tibia.

31. A knee joint prosthesis according to any of claims **26-29** and comprising at least one roller element, said femoral portion articulating with said tibial portion via said at least one roller element.

32. A knee joint prosthesis according to any of claims **26-31** and having at least one fluid passageway.

33. A bone fastener comprising a plurality of alternating adjacent portions of substantially rigid and substantially resilient materials.

34. A bone fastener comprising a plurality of alternating adjacent first and second portions, said first portion having a substantially rigid configuration and said second portion having a substantially resilient configuration.

35. A method of incision of a ligament comprising forming a substantially wave-like incision in said ligament.

36. A method of insertion of a prosthesis for a hip joint comprising:

fixedly attaching a first joint element to an upper portion of a femur, said first joint element fitting substantially snugly with said upper portion of the femur;

fixedly attaching a second joint element to a portion of an innominate bone; and

inserting an artificial femoral head intermediate said first and said second joint elements, such that said artificial femoral head articulates with at least one of said first and said second joint elements.

37. A method according to claim **36** and comprising using one or more natural ligaments to strengthen said hip joint.

38. A method according to claim **36** and comprising using a one or more artificial ligaments to strengthen said hip joint.

39. A method for limiting a range of movement of a hip joint comprising:

implanting a hip joint prosthesis comprising at least one delimiting rail and at least one delimiting groove, said at least one delimiting rail articulating with said at least one delimiting groove, such that said at least one delimiting groove limits articulation of said at least one delimiting rail therein.

* * * * *