



US 20080134601A1

(19) **United States**
(12) **Patent Application Publication**
Cruz

(10) **Pub. No.: US 2008/0134601 A1**
(43) **Pub. Date: Jun. 12, 2008**

(54) **OFFICE WORKSTATION ASSEMBLY**

Publication Classification

(75) Inventor: **Alexander Cruz**, Castle Rock, CO
(US)

(51) **Int. Cl.**
E04H 1/12 (2006.01)

(52) **U.S. Cl.** **52/236.2**

Correspondence Address:
SCHWEGMAN, LUNDBERG & WOESSNER,
P.A.
P.O. BOX 2938
MINNEAPOLIS, MN 55402

(57) **ABSTRACT**

One example embodiment disclosed herein includes a modular office furniture arrangement wherein the arrangement is circular with desks in each workstation area facing toward the outside circumference of the circle and fixed partition walls extend radially outward from a center of the circular arrangement to provide pie-shaped workstation areas. A sliding partition wall may be provided in some embodiments. The sliding partition wall may slide out of a pocket in the fixed partition wall to provide additional portioning of the workstation areas. The sliding portion may slide to extend vertically in some embodiments and may slide to extend horizontally in other embodiments.

(73) Assignee: **Apaxis Systems, Inc**

(21) Appl. No.: **11/763,981**

(22) Filed: **Jun. 15, 2007**

Related U.S. Application Data

(60) Provisional application No. 60/805,067, filed on Jun. 16, 2006.

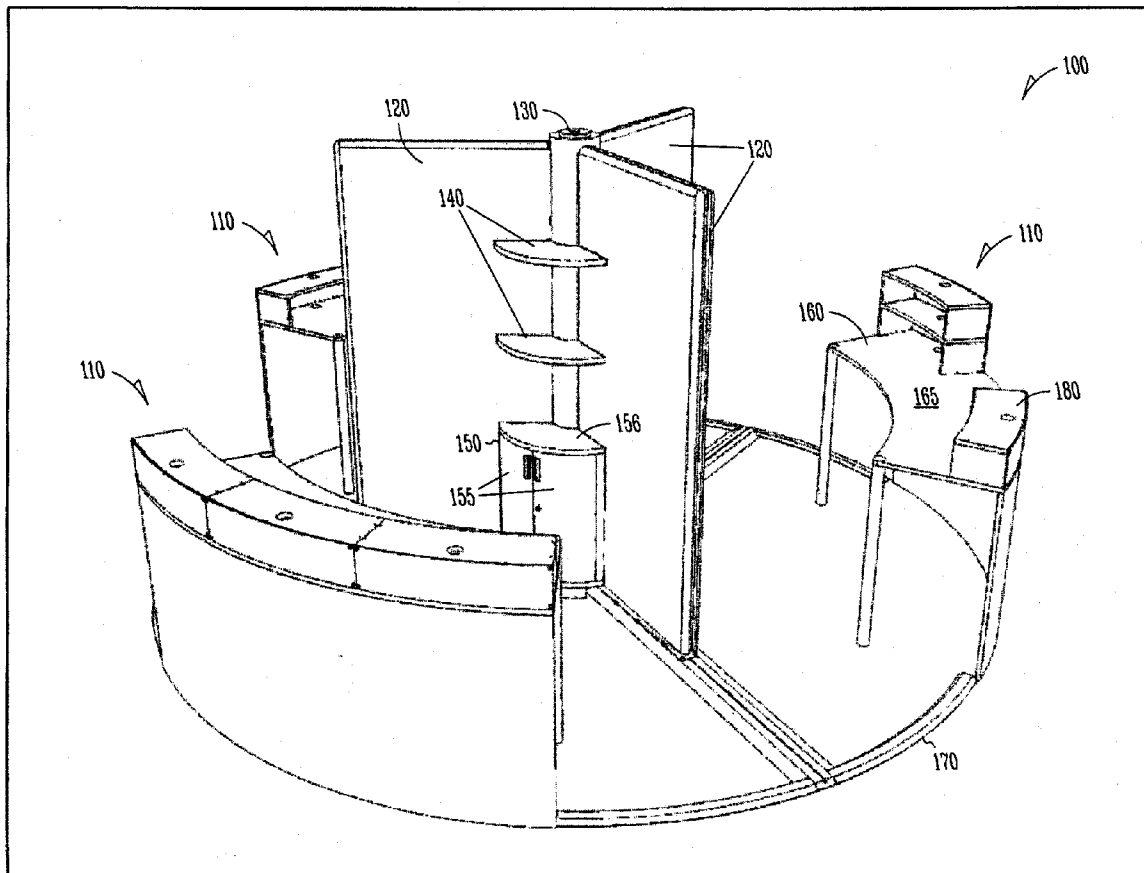

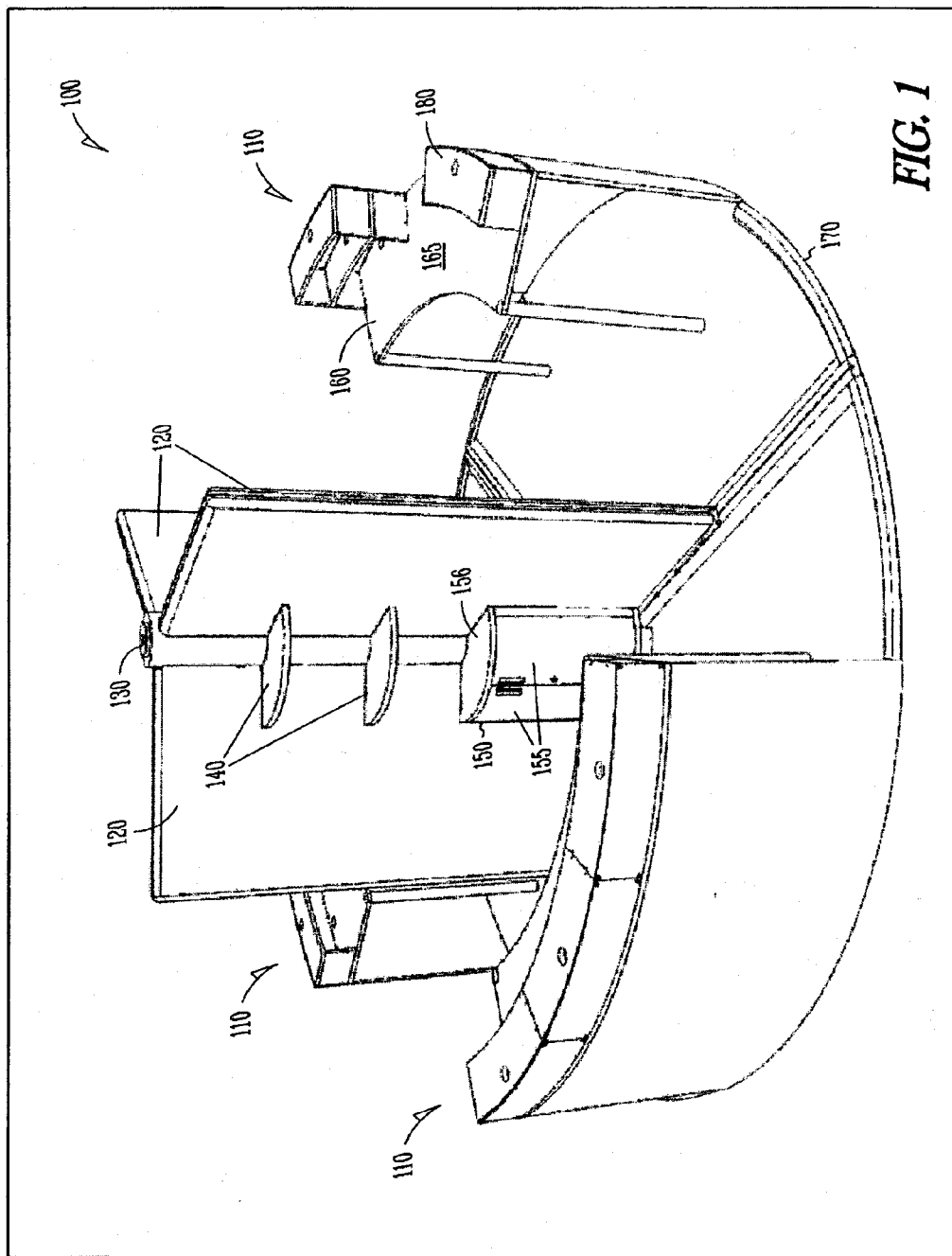

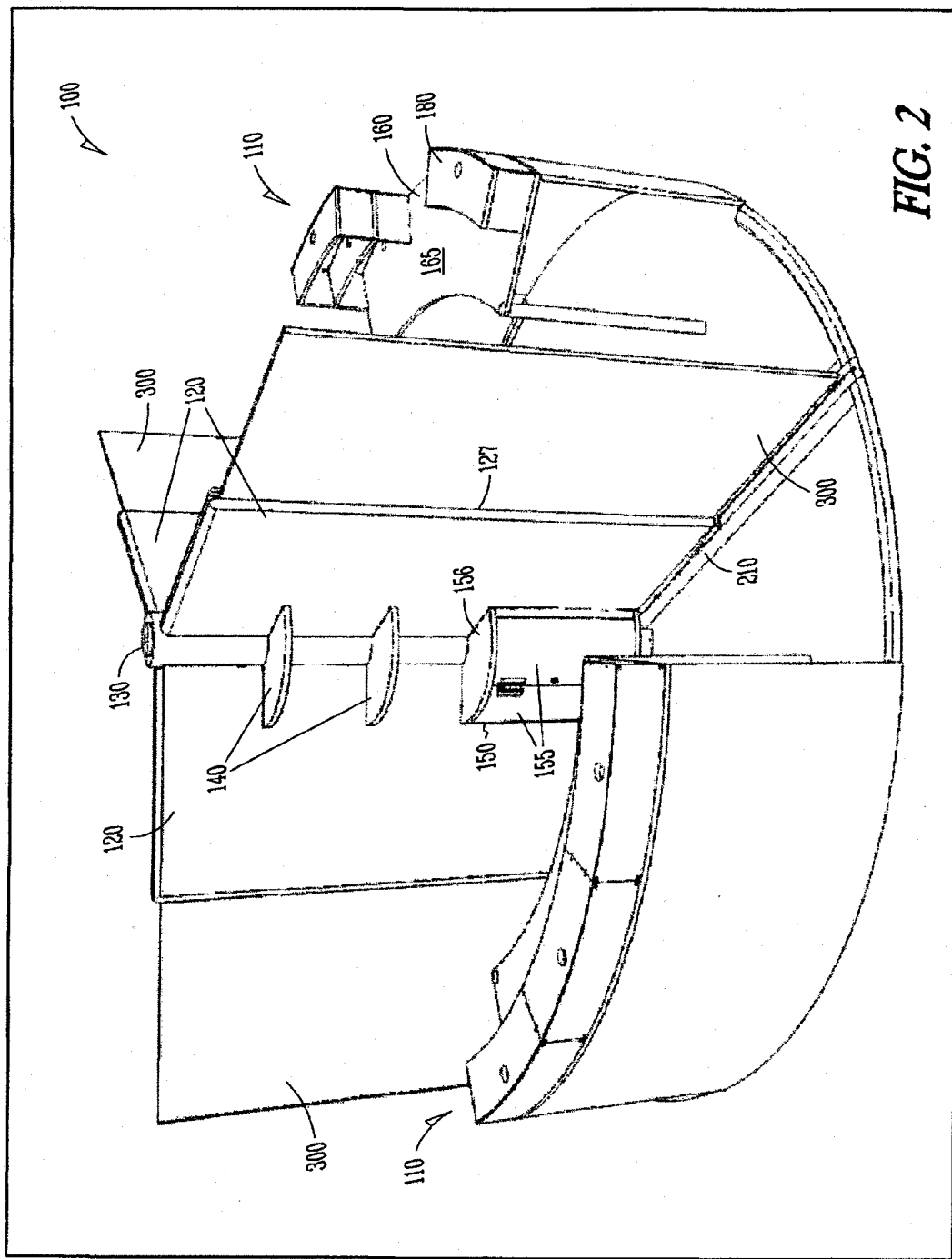

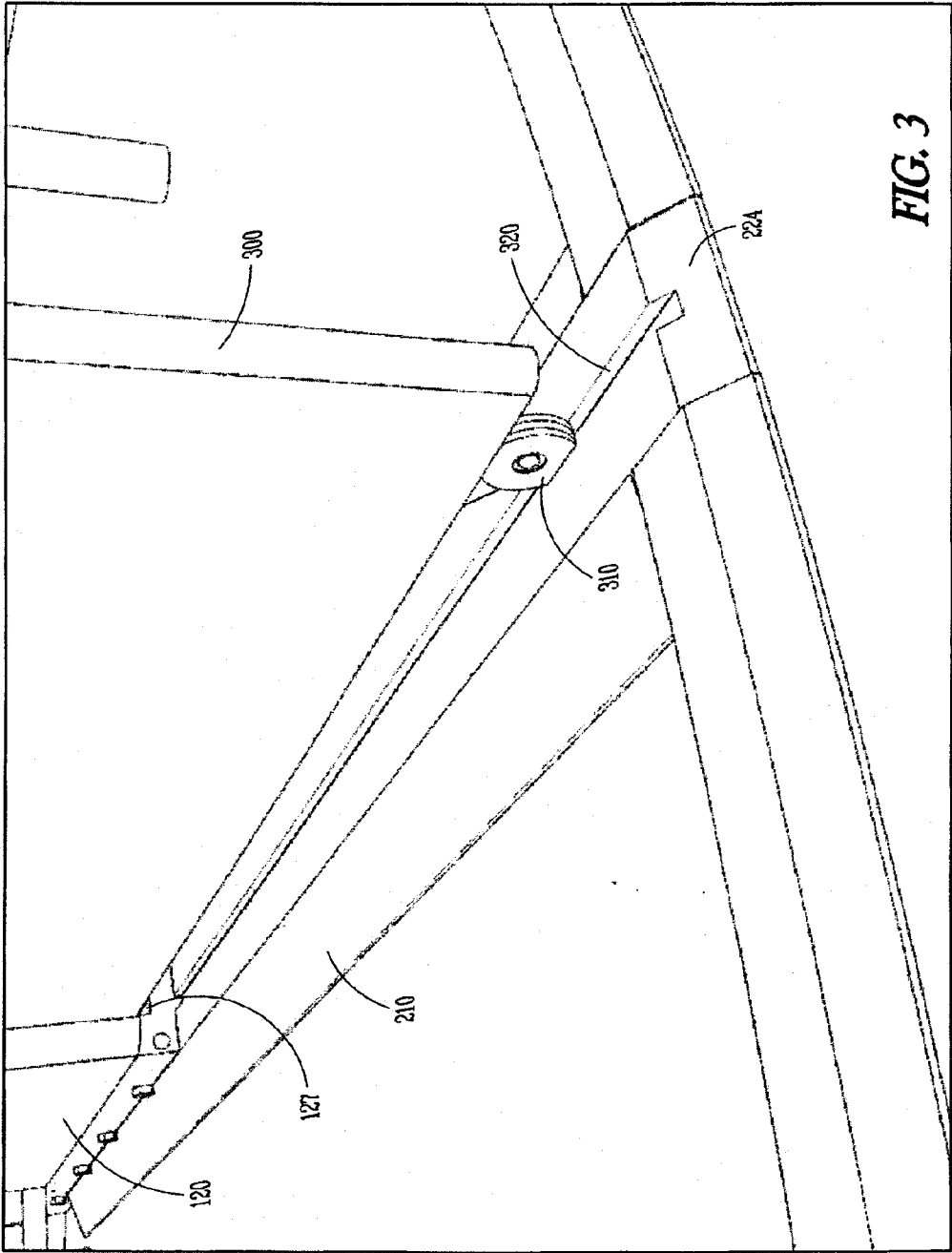

FIG. 3

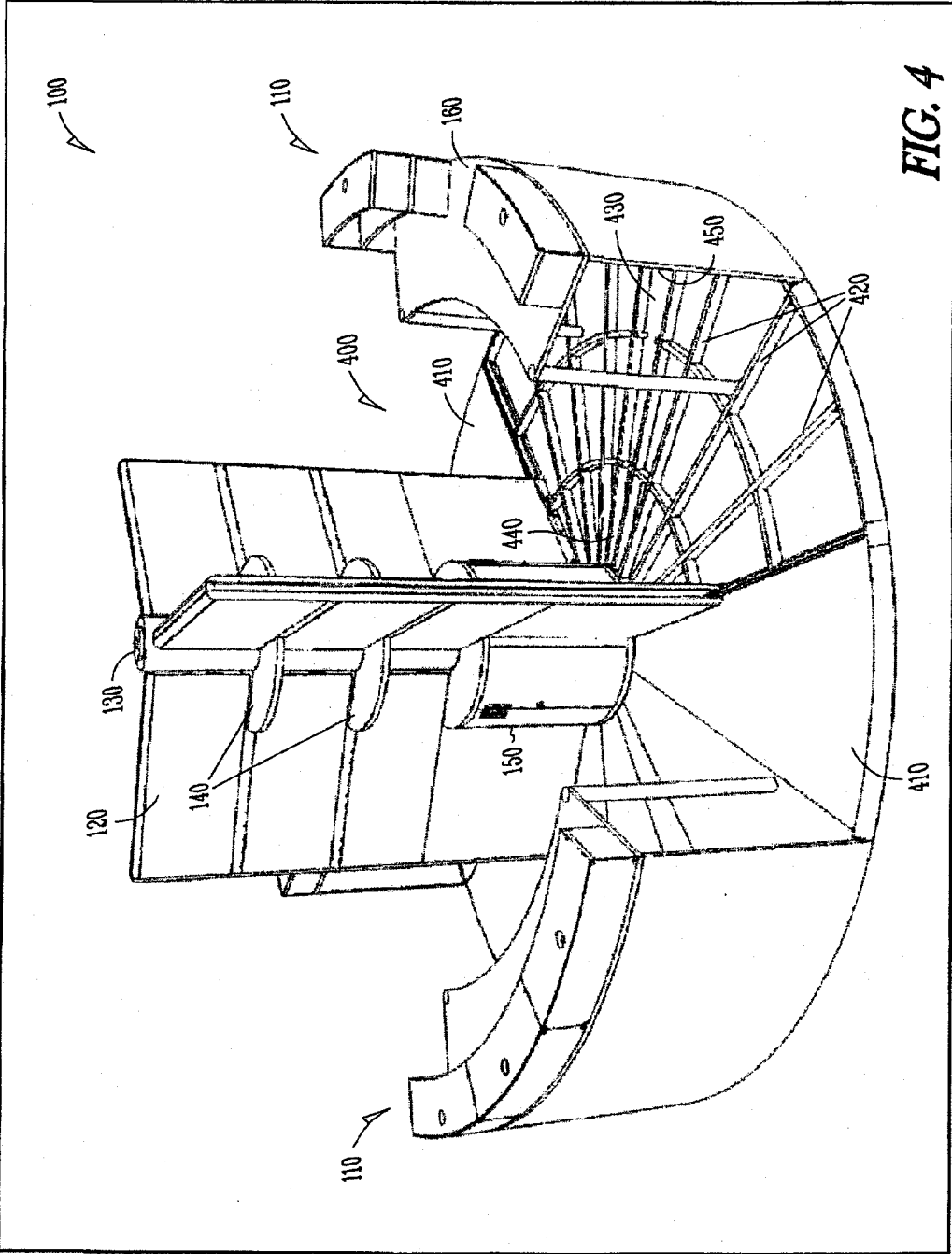
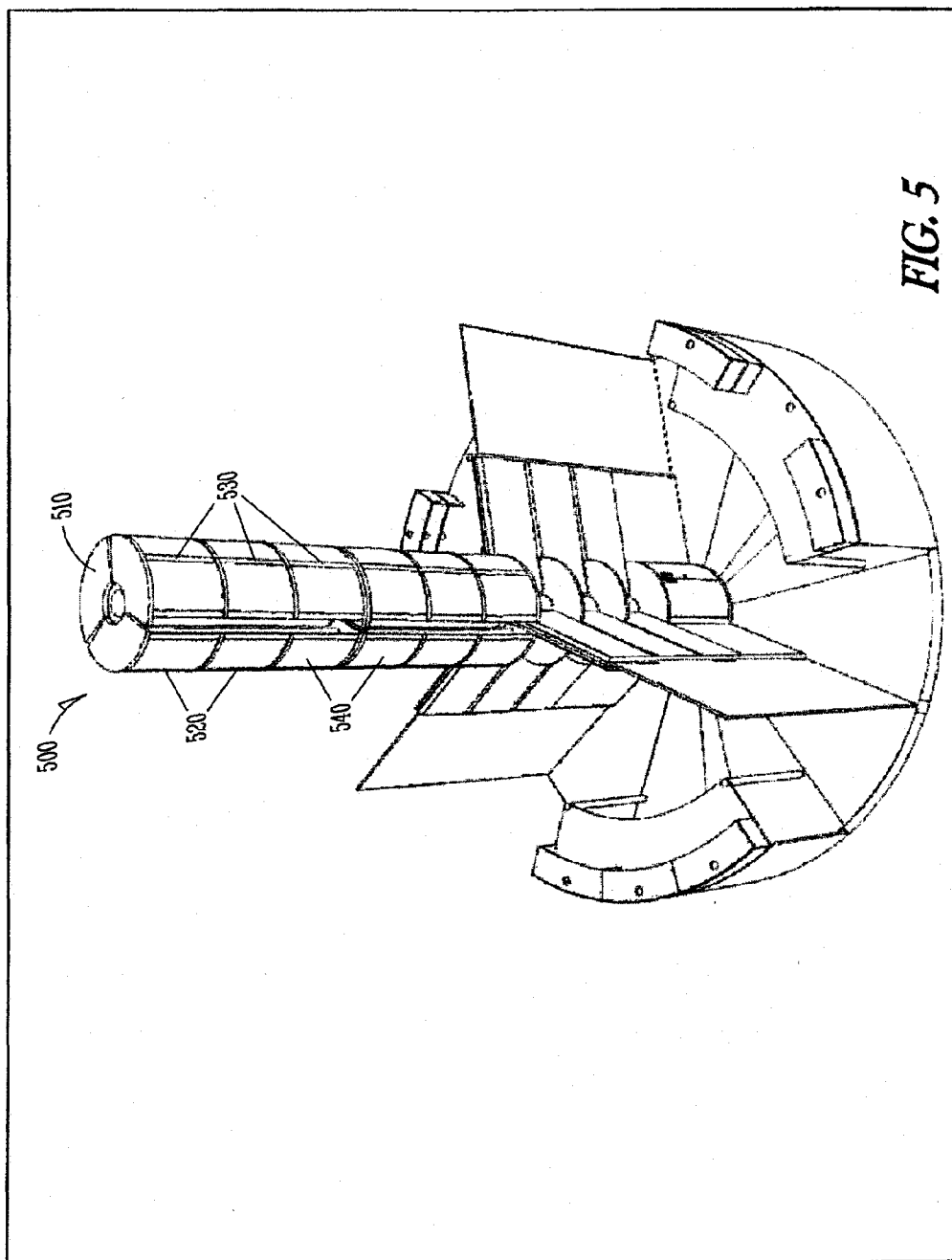

FIG. 4



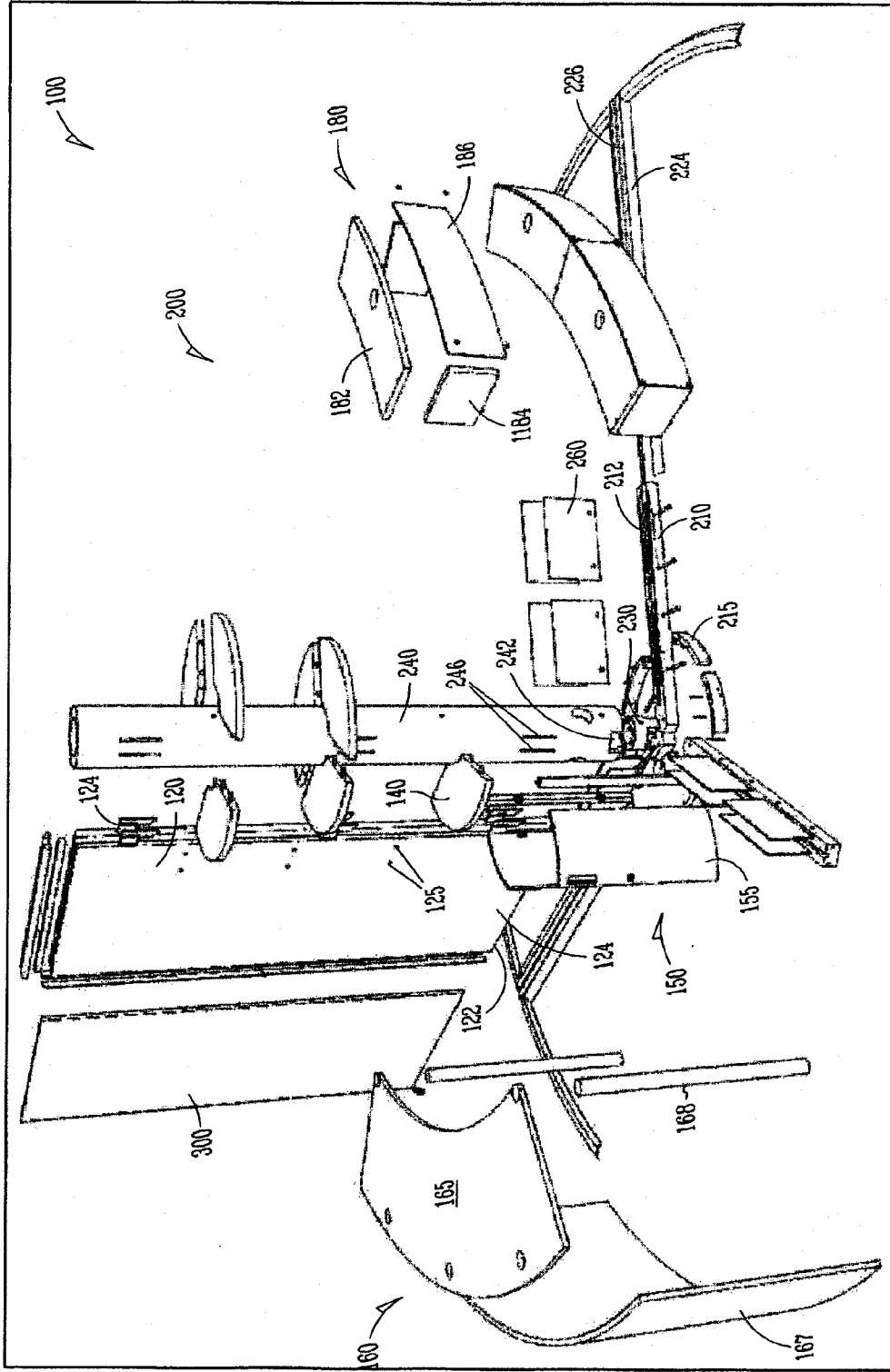
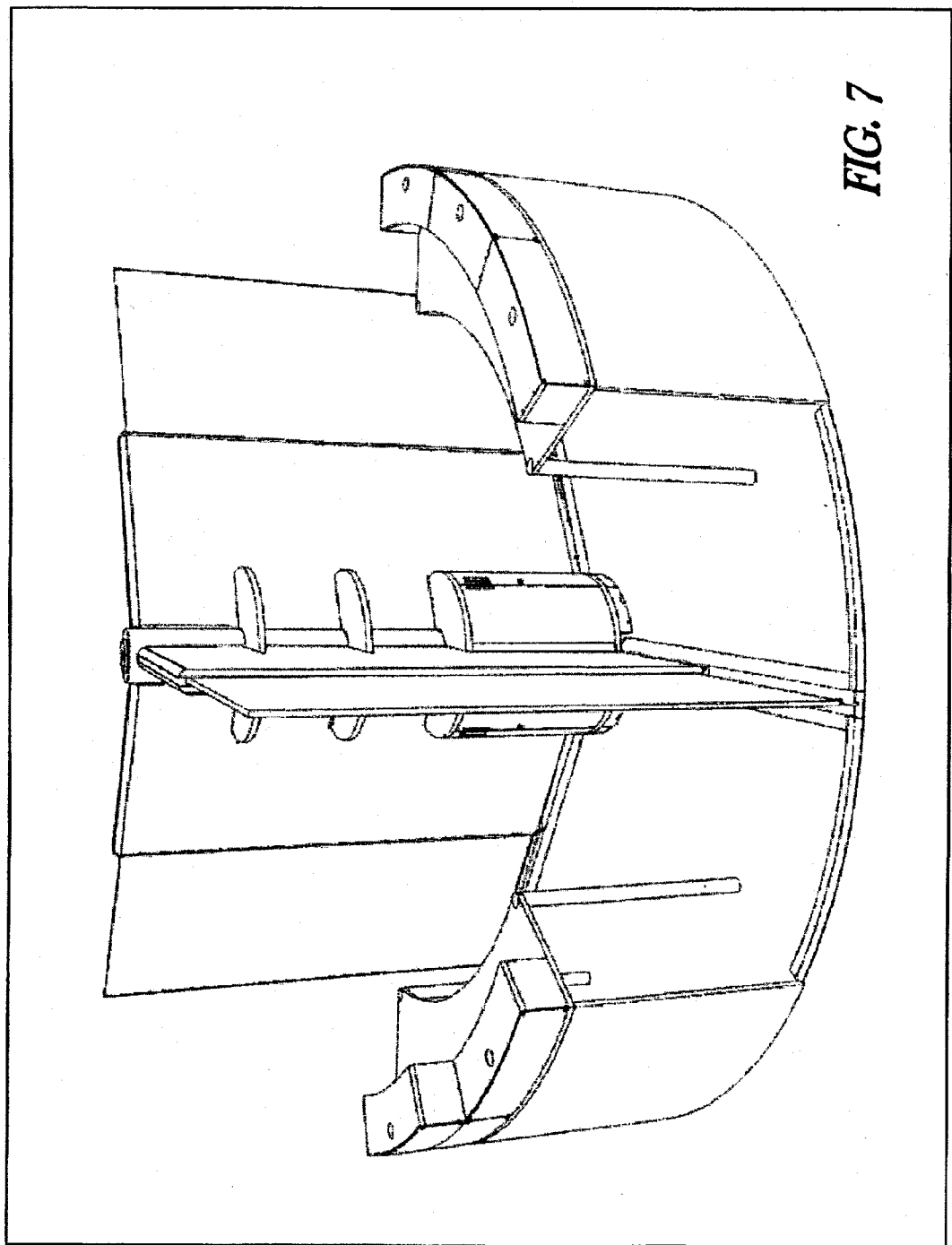
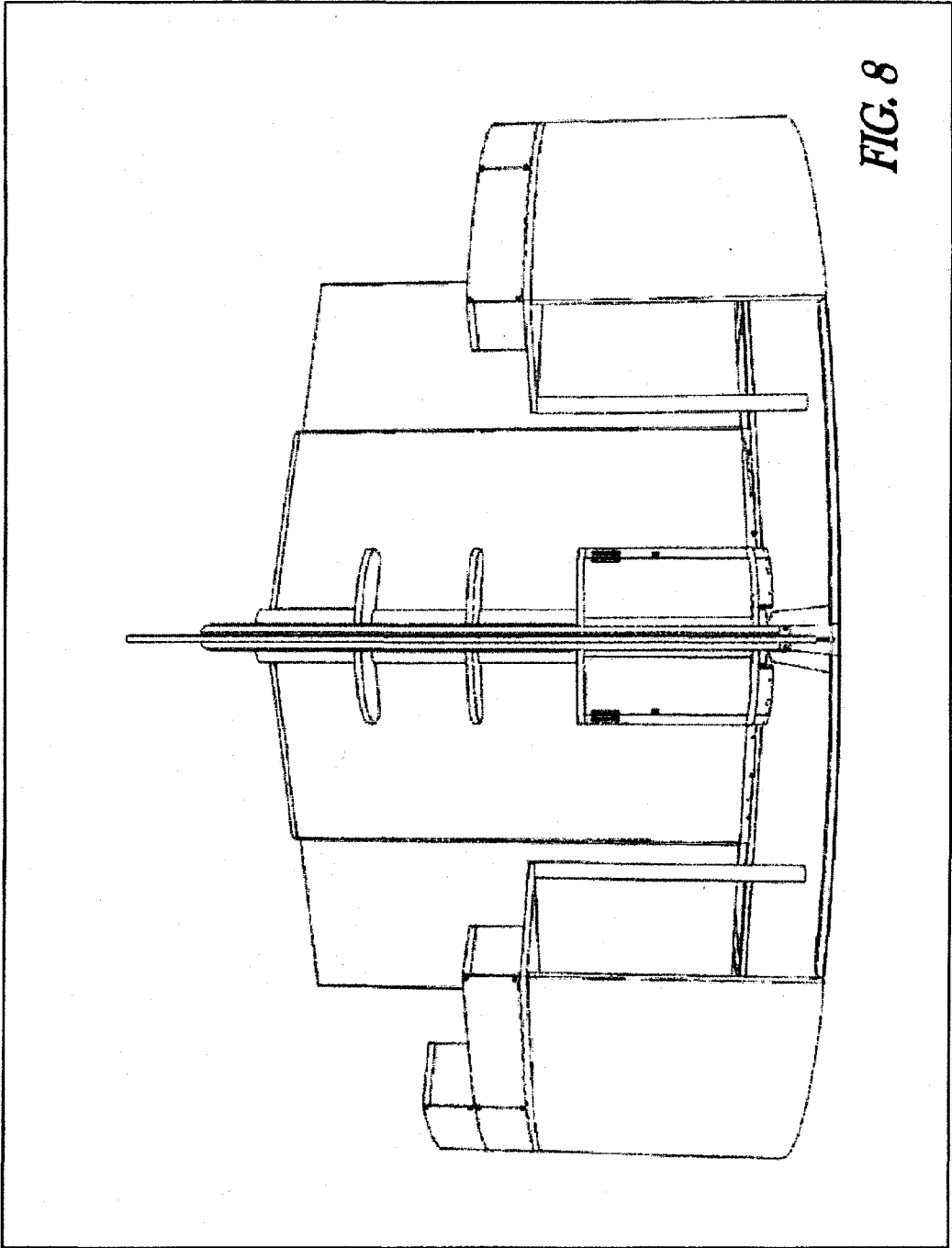
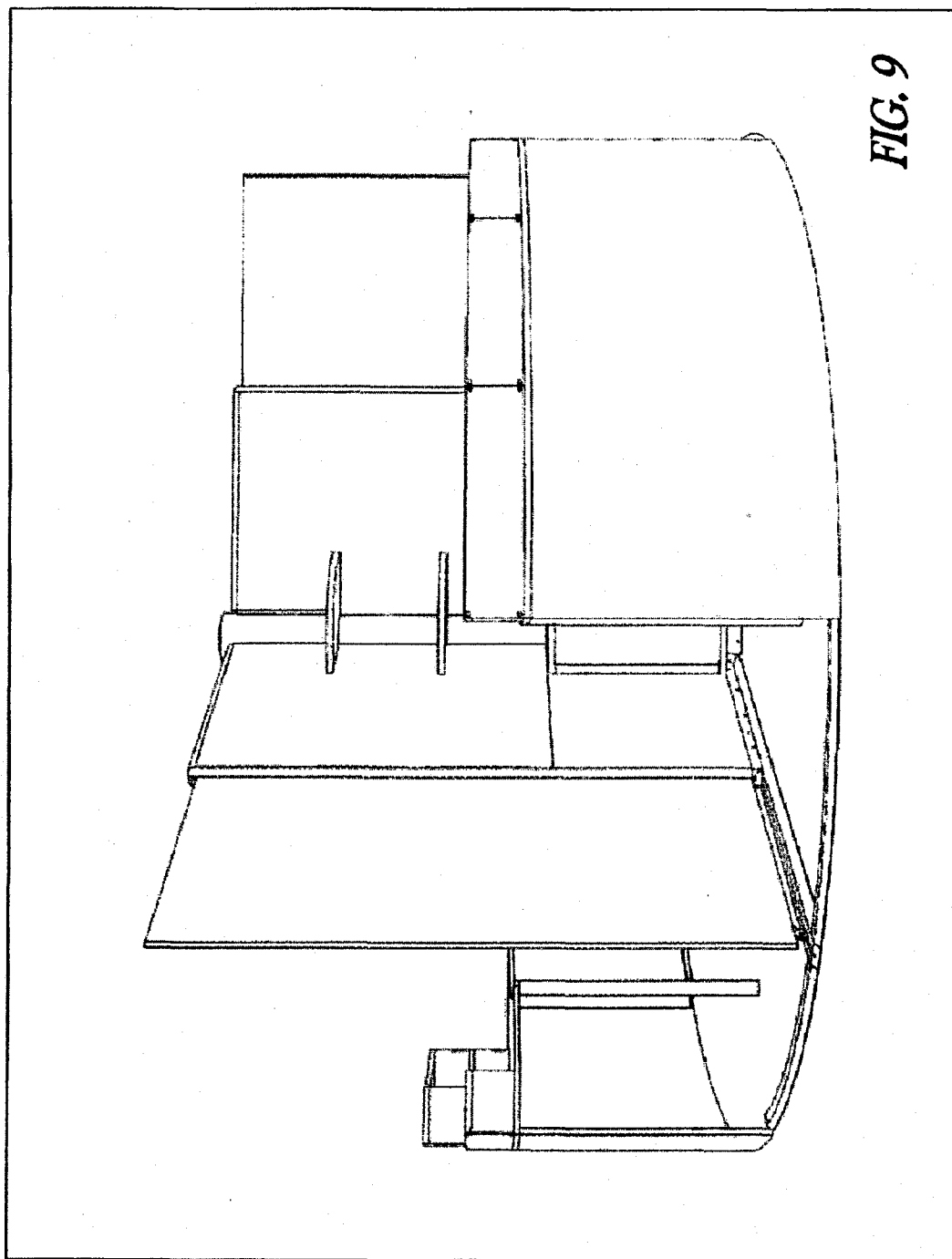
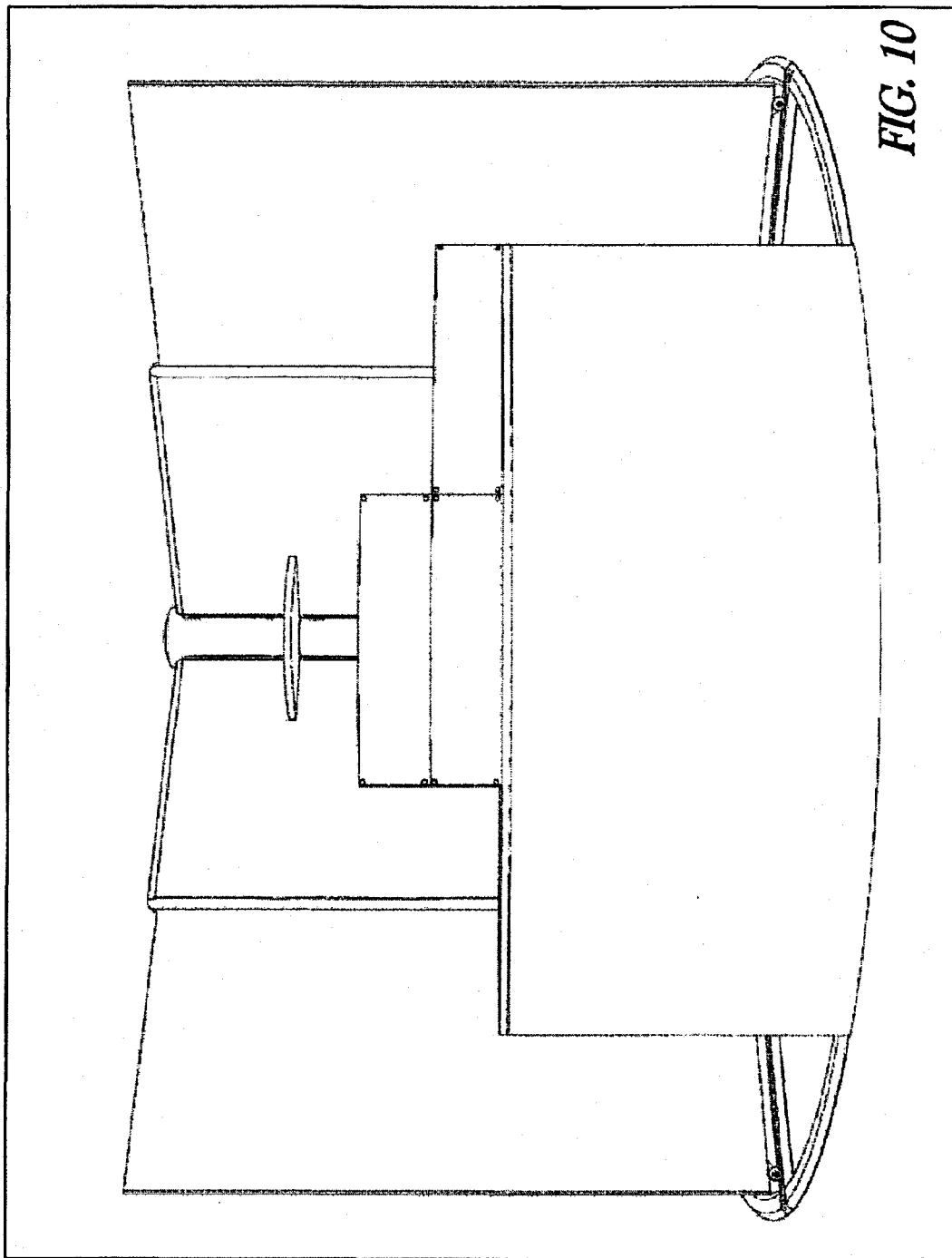

FIG. 6









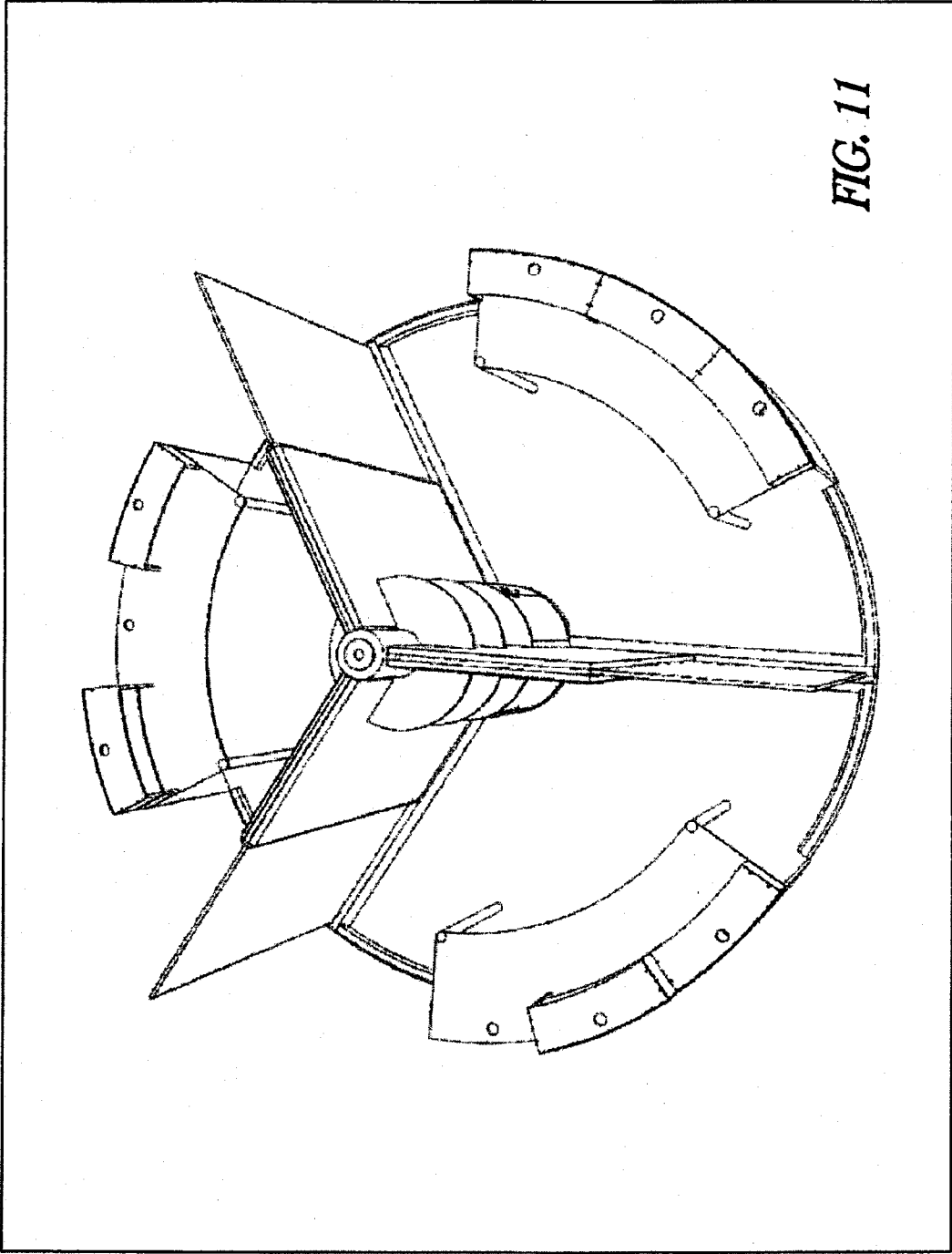

FIG. 11

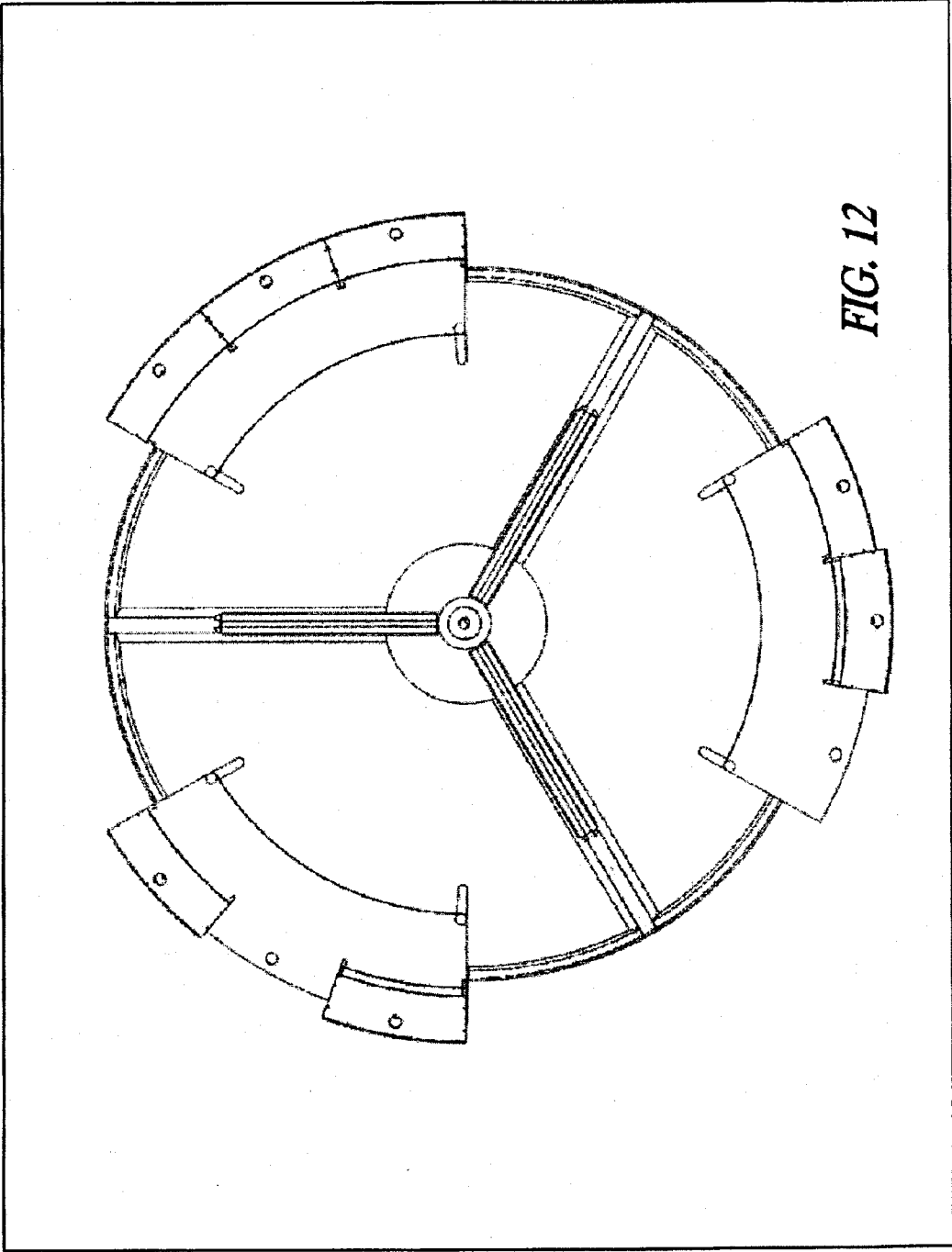
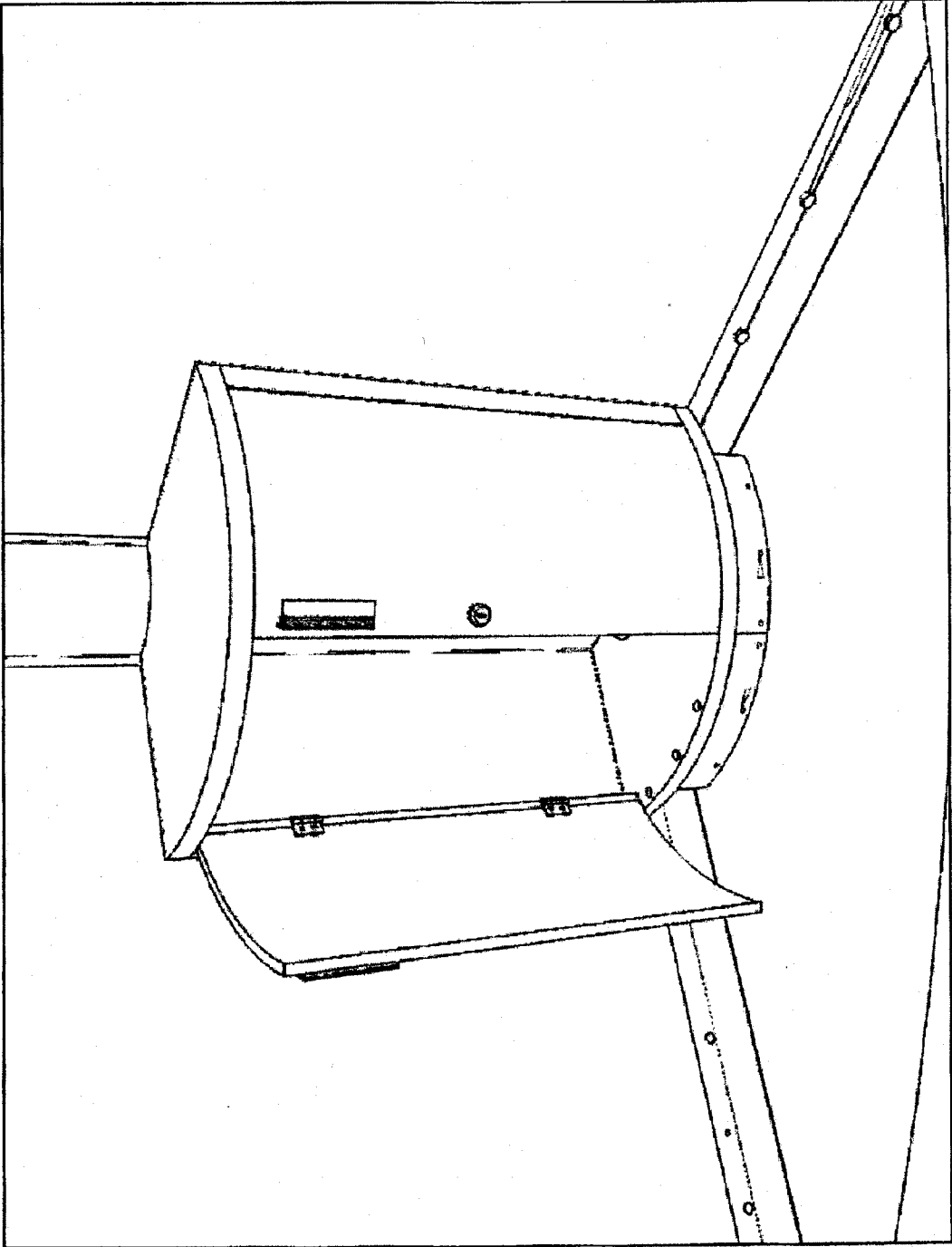
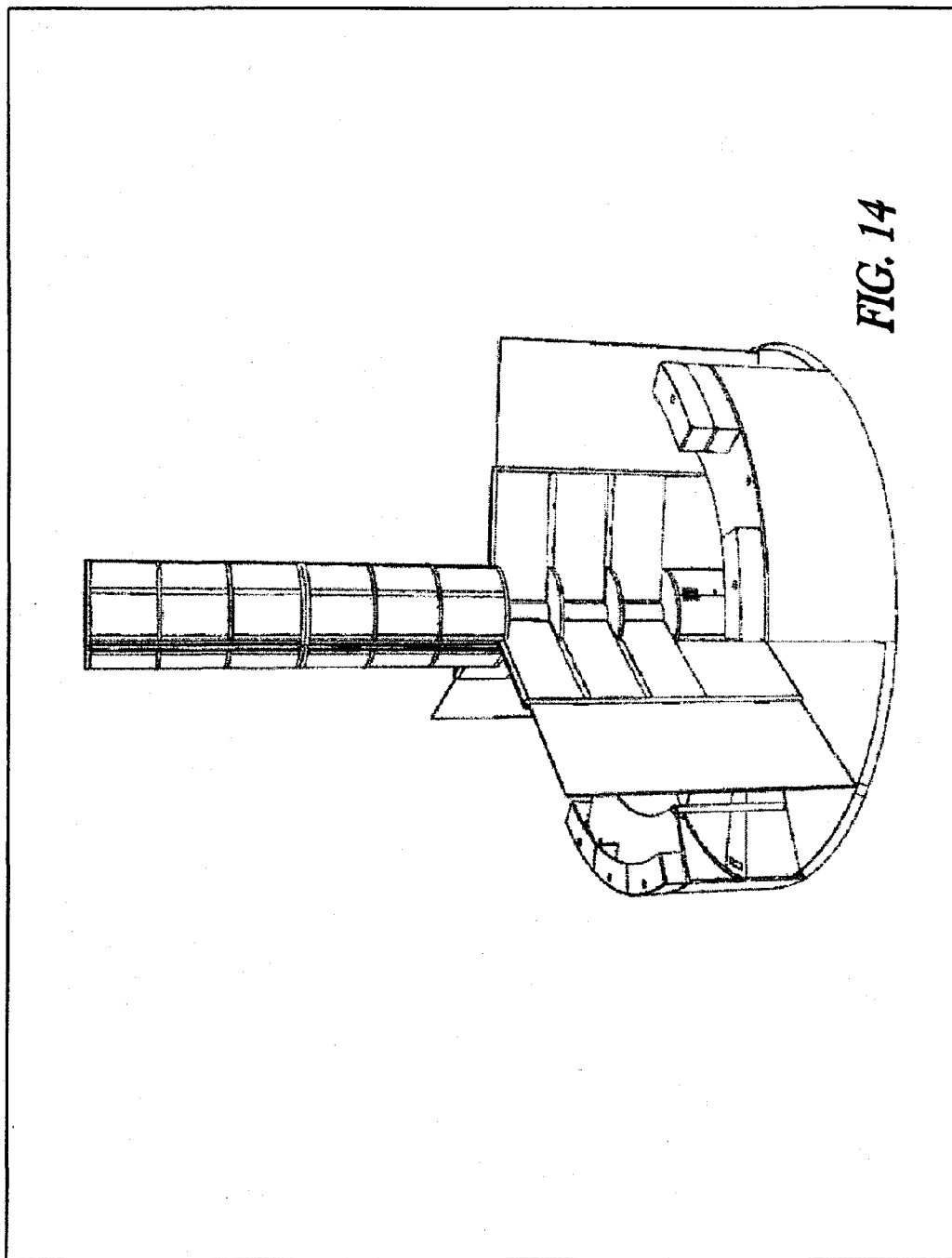
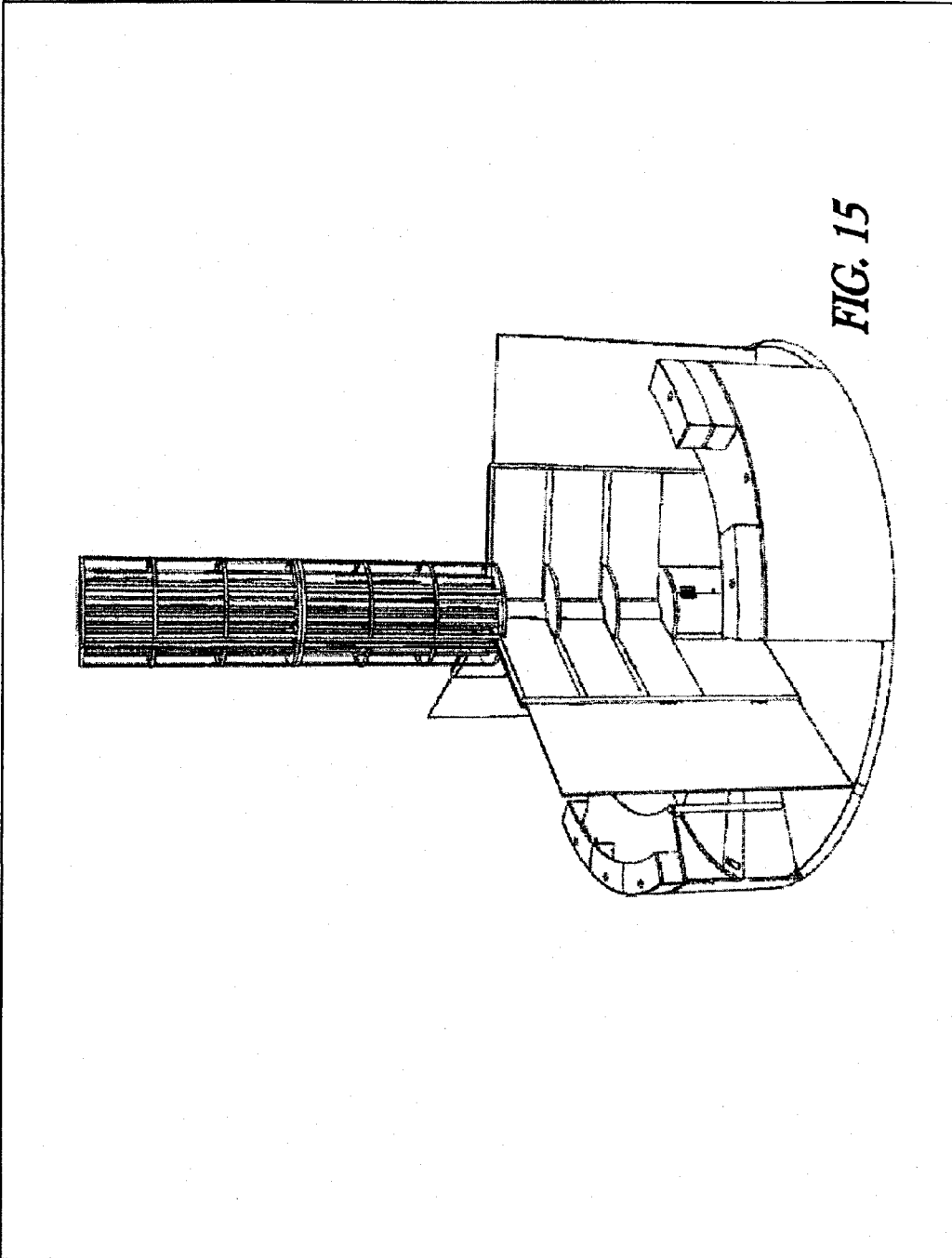

FIG. 12

FIG. 13







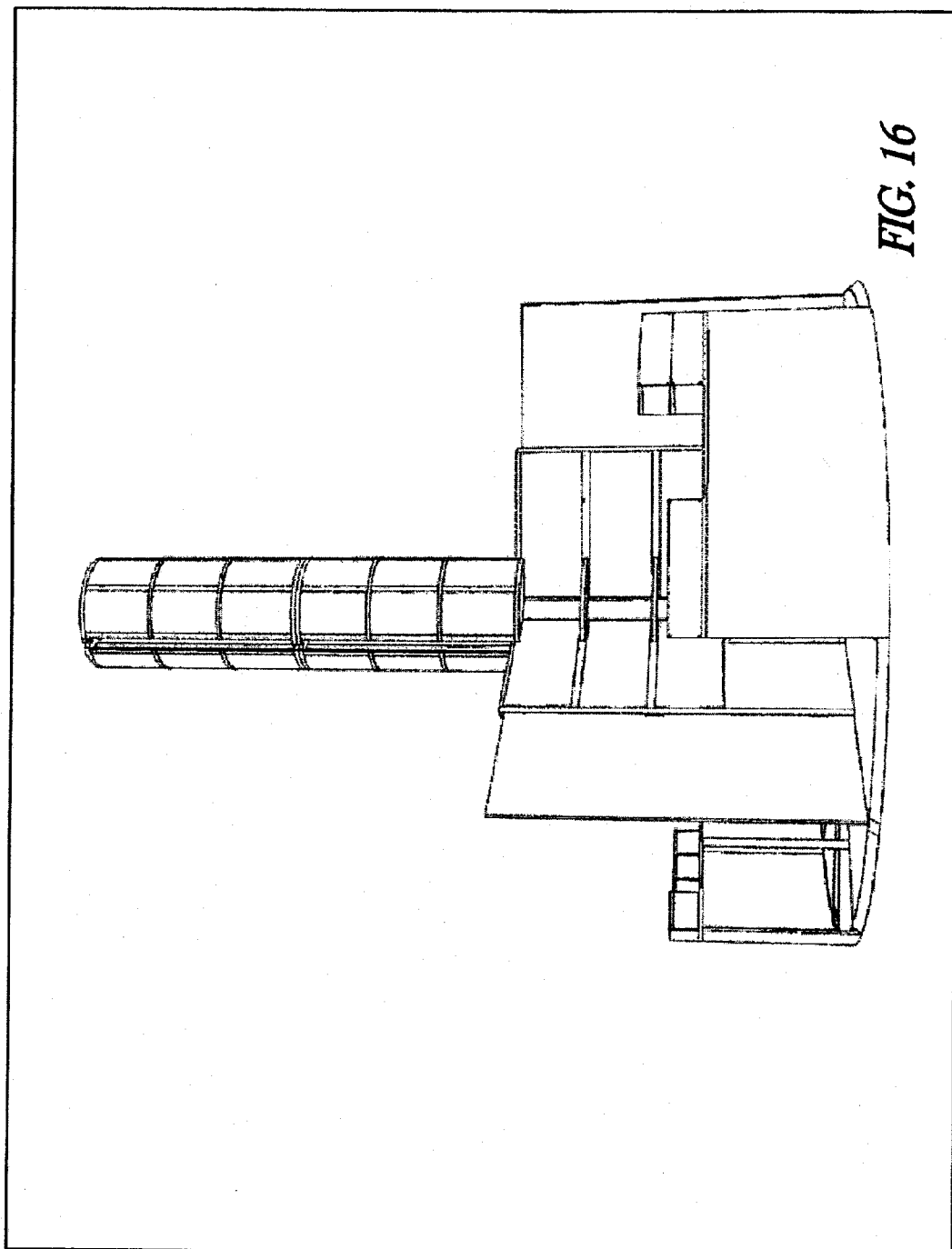

FIG. 16

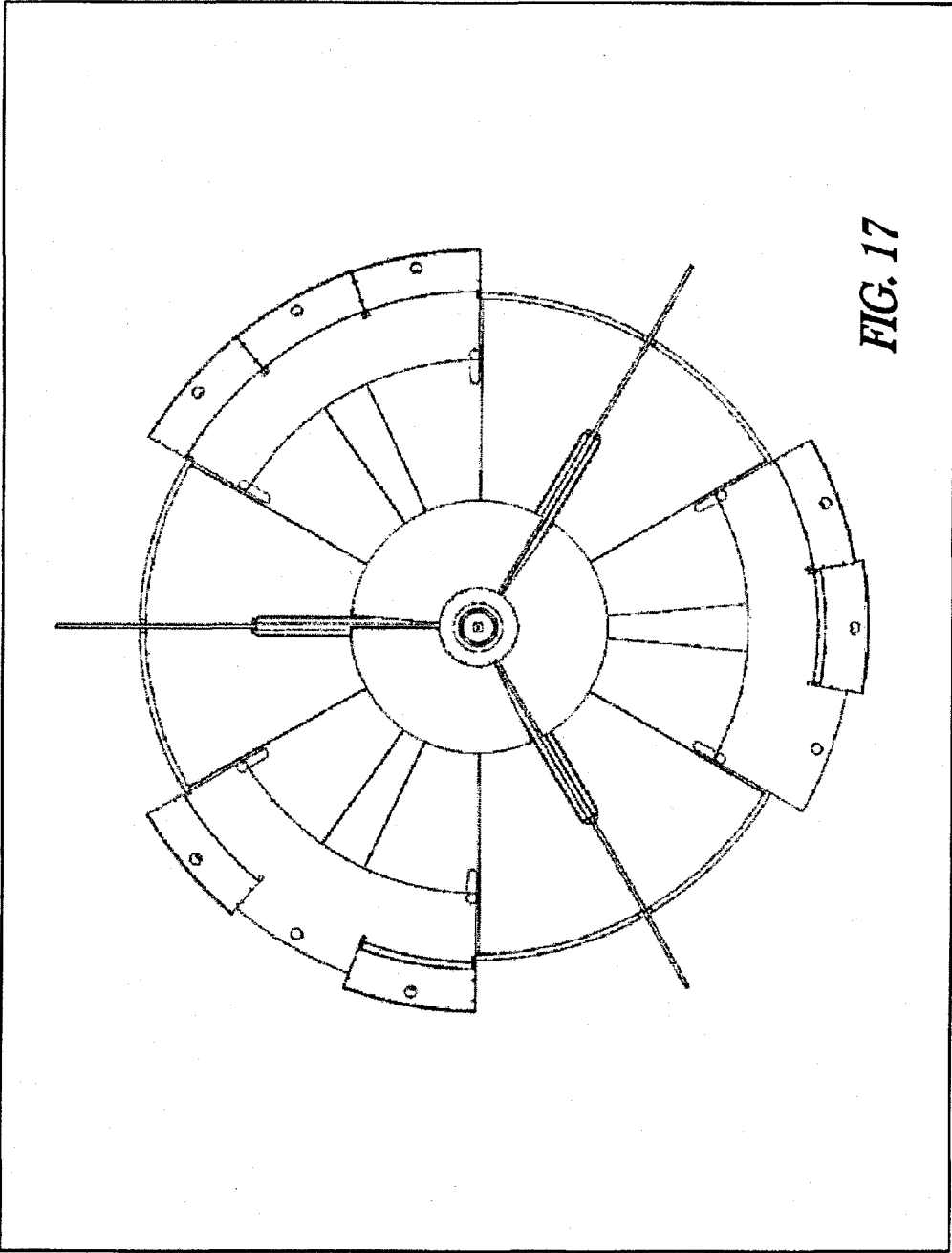
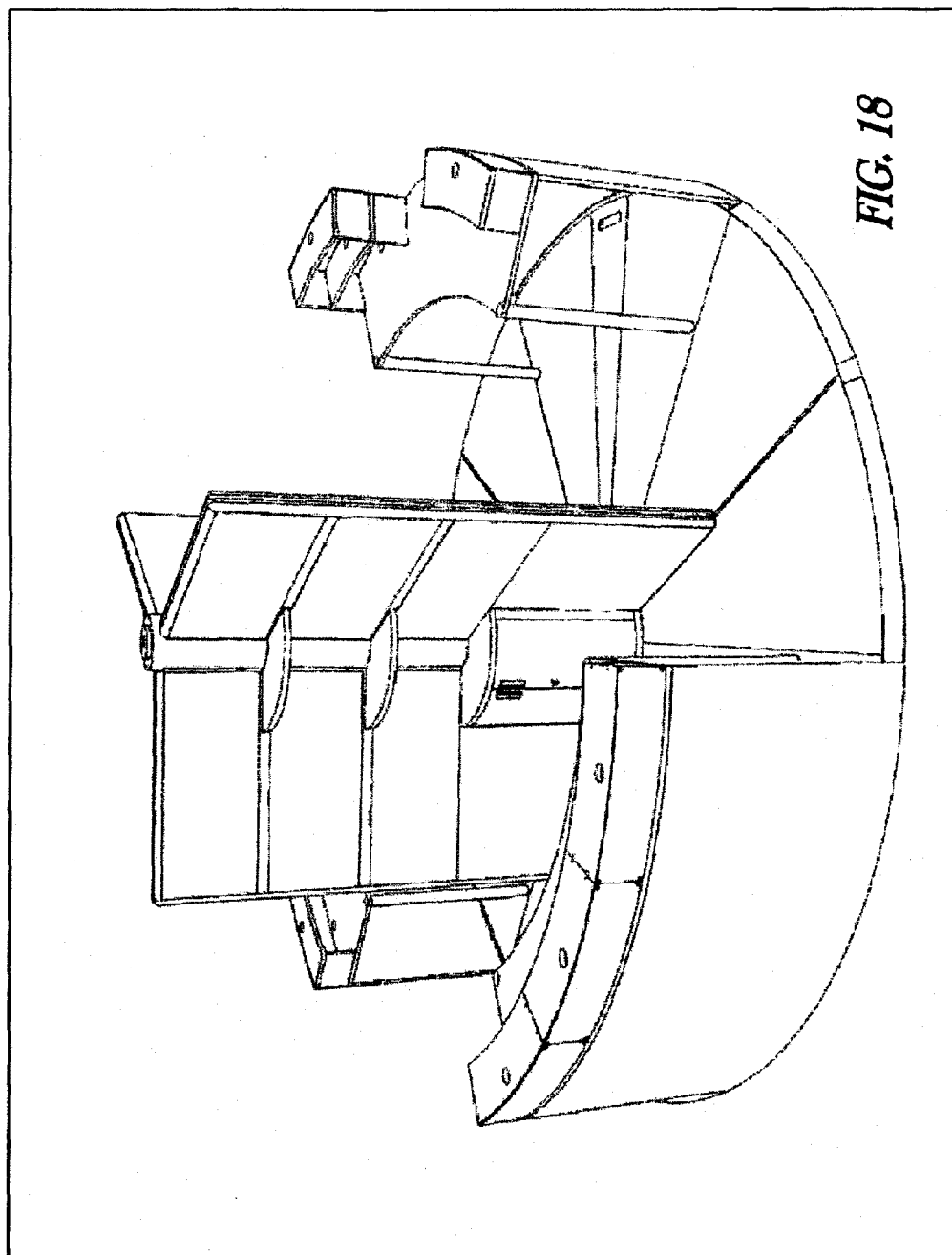
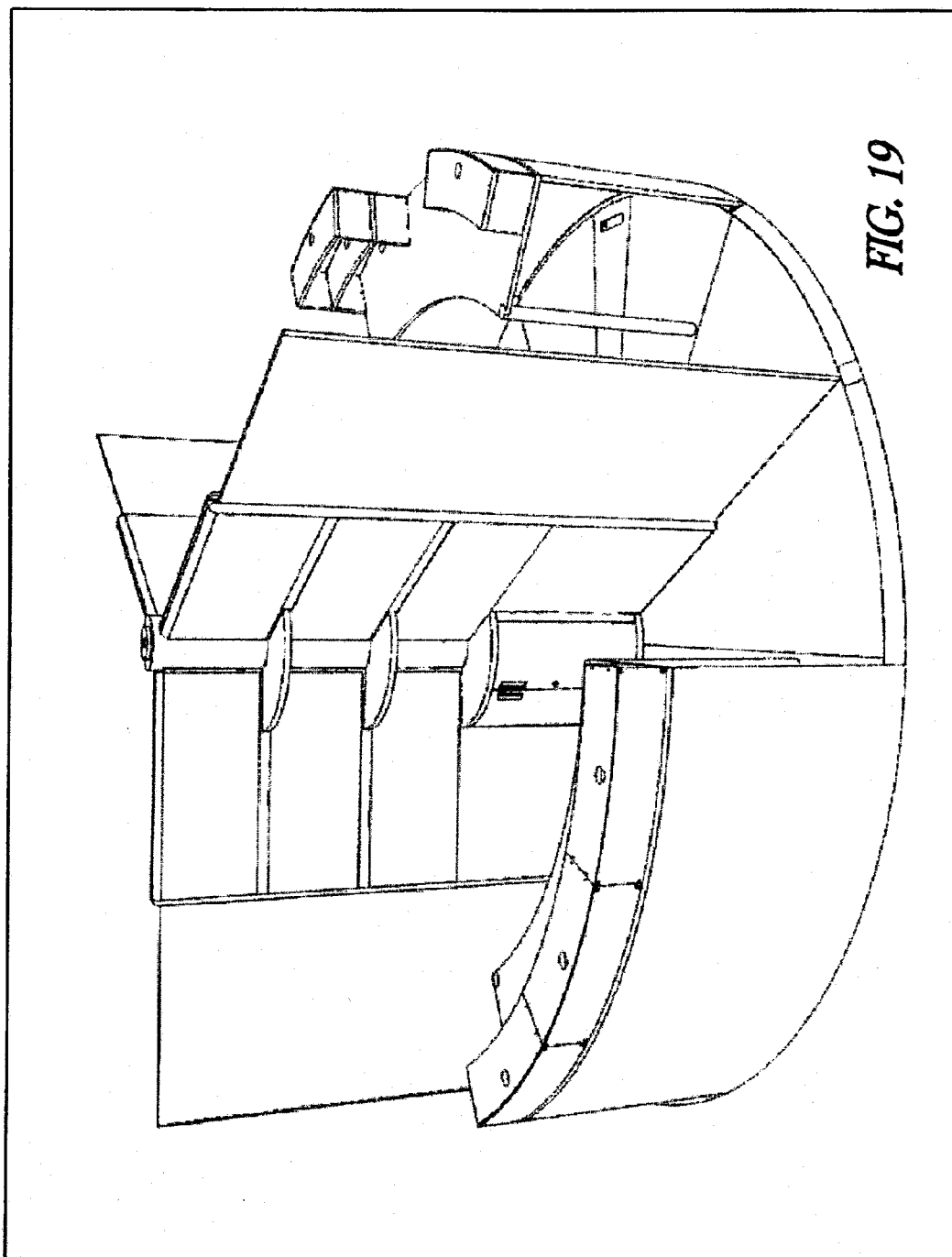

FIG. 17





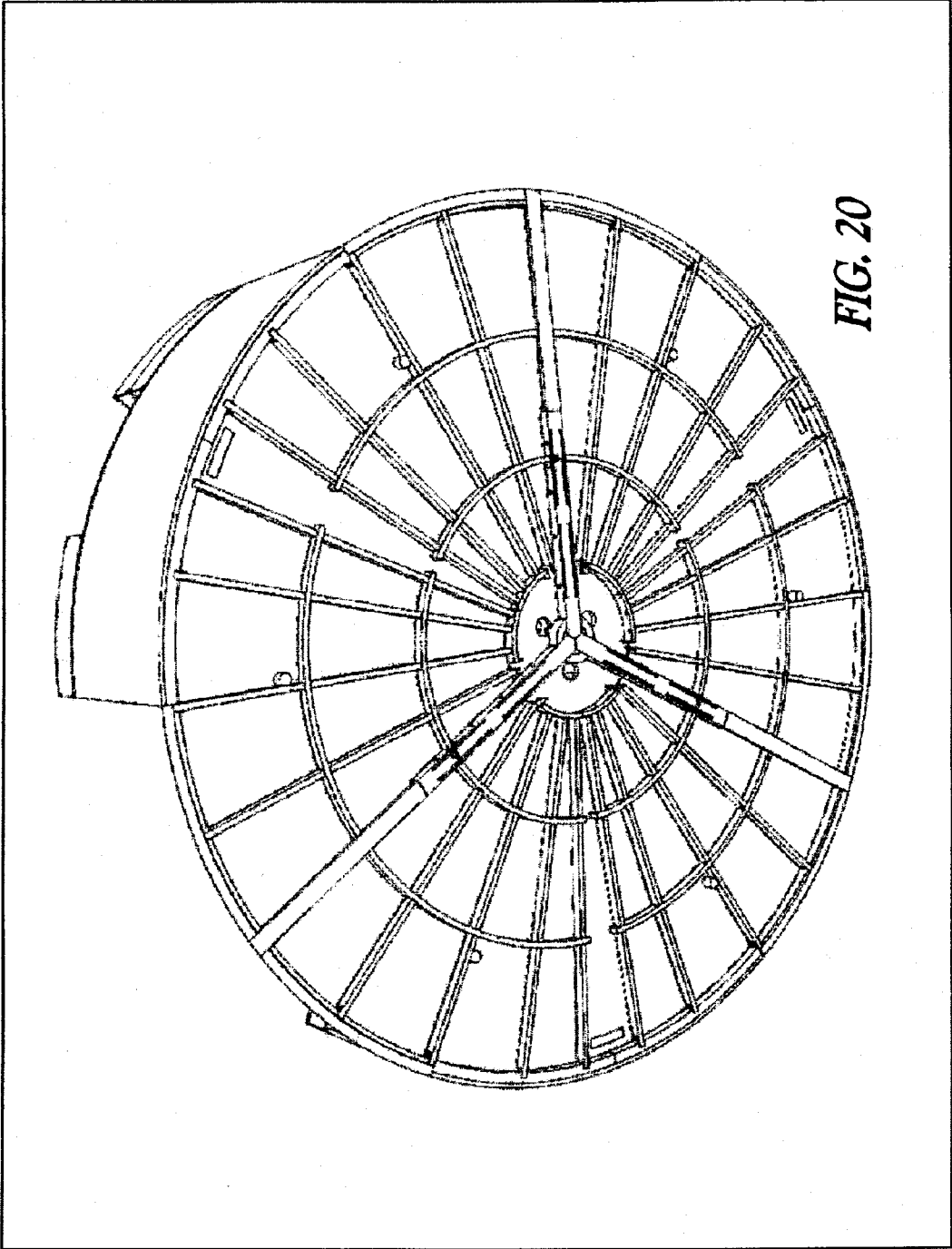

FIG. 21

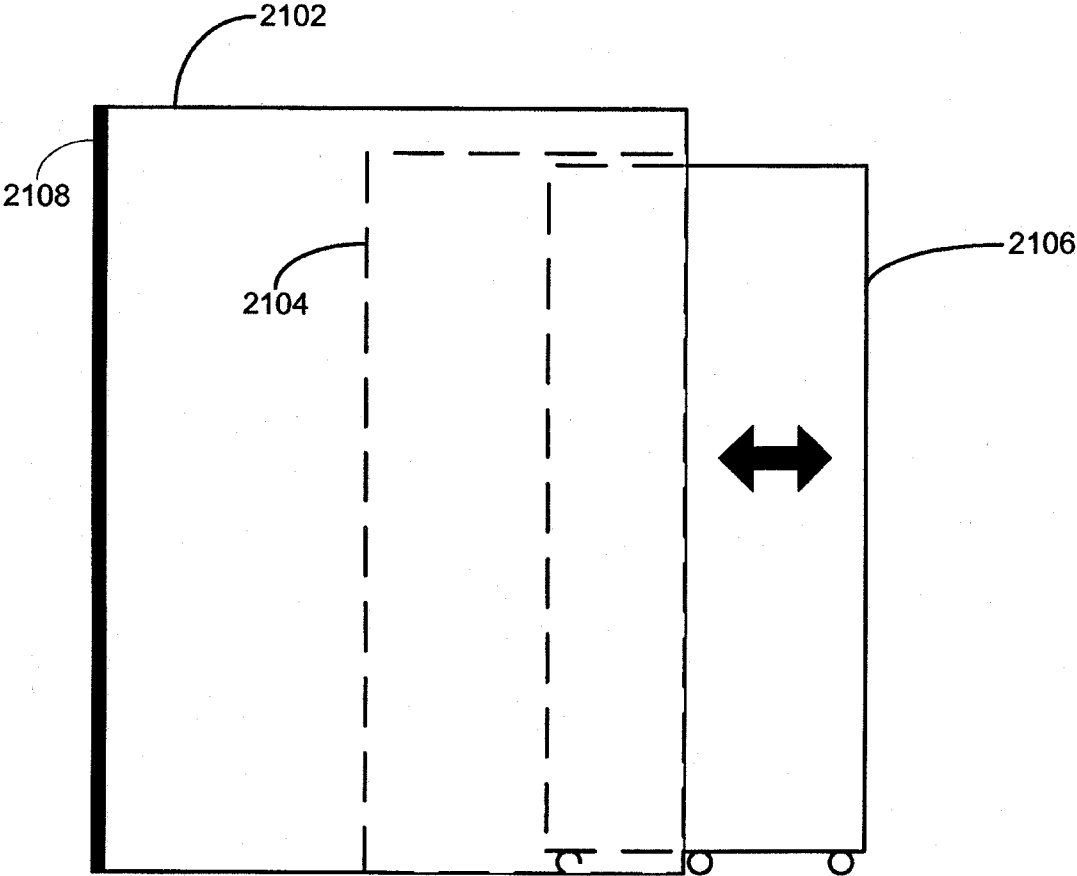

FIG. 22

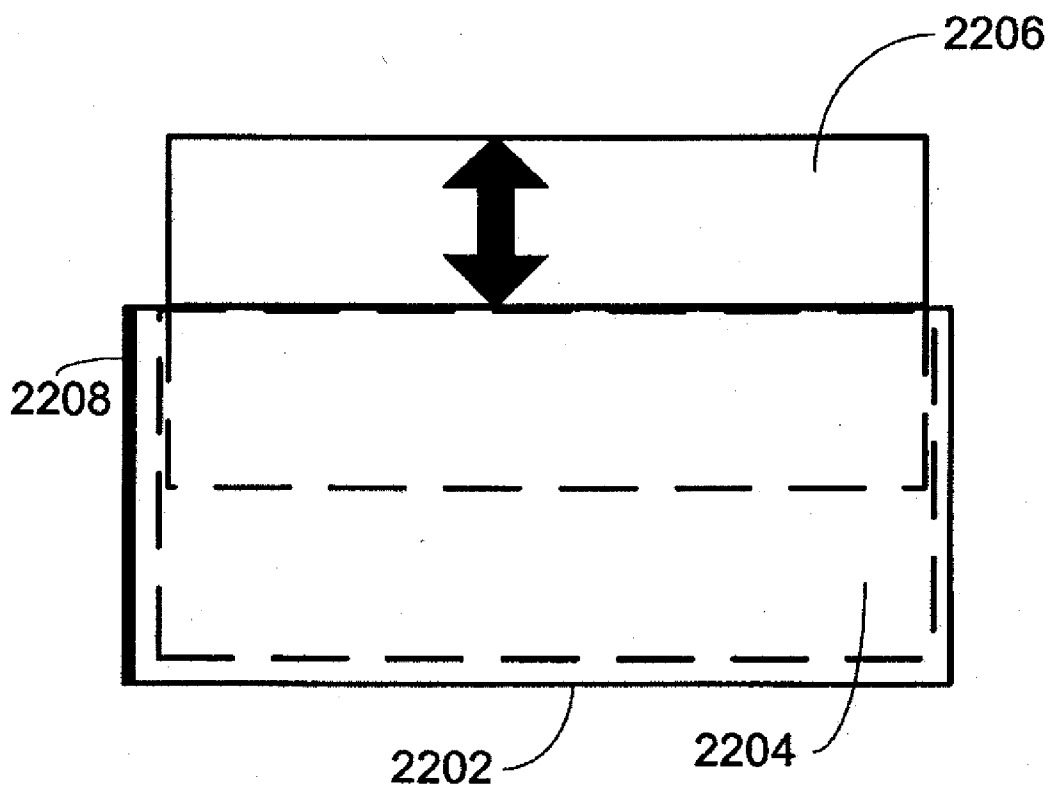
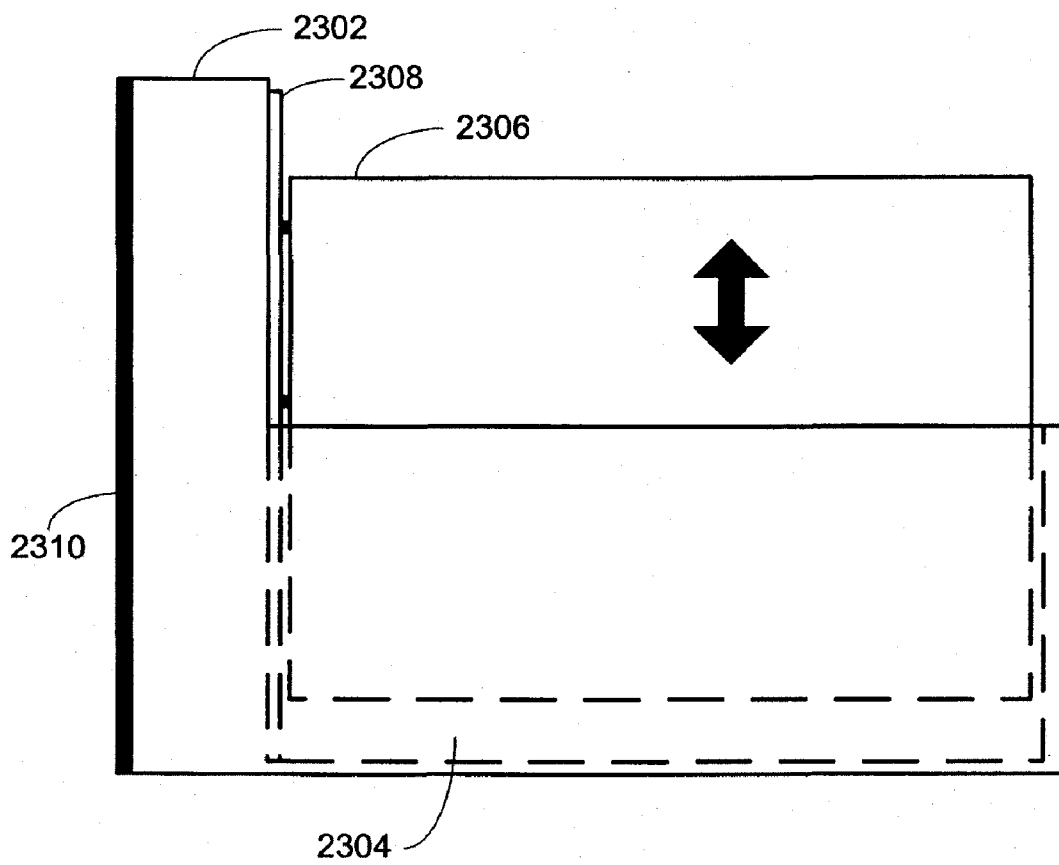

FIG. 23



OFFICE WORKSTATION ASSEMBLY

CROSS-REFERENCE TO RELATED APPLICATIONS

[0001] This application claims the benefit of the filing date of U.S. Provisional Application No. 60/805,067, filed on Jun. 16, 2006, the entire disclosure of which is incorporated herein by reference.

TECHNICAL FIELD

[0002] The subject matter herein relates generally to the field of furniture, and more particularly to modular office furniture.

BACKGROUND

[0003] Modular office furniture, commonly taking the form of "cubicles", is in widespread use throughout the industrialized world. Such cubicles, however, may be cramped and may lack actual if not a feeling of privacy for the occupant. At the same time, other cubicles provide so much privacy that they make occupants feel cramped. Office worker productivity, on the other hand, may be enhanced if the office worker's working environment provides a more psychologically enjoyable space with an efficient arrangement.

SUMMARY

[0004] According to one example embodiment disclosed herein includes a modular office furniture arrangement wherein the arrangement is circular with desks in each workstation area facing toward the outside circumference of the circular area and flexible partition walls. The partition walls in some embodiments extend radially outward from a center of the circular arrangement to provide semi-circular, pie-shaped workstation areas. A sliding partition wall may be provided and slide out of a pocket in the fixed partition wall to provide additional portioning of the workstation areas. The sliding partitions, in various embodiments, may slide in horizontal or vertical directions. In some embodiments including sliding partitions that slide in a vertical direction, the partition wall extends radially outward from the center of the circular arrangement, but only provides half-height walls. These half-height walls include the sliding partition which may be raised and lowered to provide more privacy or more openness. These and various other example embodiments of the inventive subject matter are disclosed herein.

BRIEF DESCRIPTION OF DRAWINGS

- [0005] FIGS. 1-3 illustrate one example embodiment of the inventive subject matter disclosed herein.
- [0006] FIG. 4 illustrates another example embodiment of the inventive subject matter disclosed herein.
- [0007] FIG. 5 illustrates another example embodiment of the inventive subject matter disclosed herein.
- [0008] FIG. 6 is an exploded perspective view of one example embodiment of the inventive subject matter disclosed herein.
- [0009] FIGS. 7-20 illustrate various other views of the embodiments described in FIGS. 1-6.
- [0010] FIG. 21 illustrates a partition wall with a sliding partition that slides horizontally.
- [0011] FIG. 22 illustrates a partition wall with a sliding partition that slides vertically.

[0012] FIG. 23 illustrates a partition wall with a sliding partition that slides vertically.

DETAILED DESCRIPTION

[0013] In the following detailed description of the invention, reference is made to the accompanying drawings which form a part hereof, and in which is shown, by way of illustration, specific embodiments in which the invention may be practiced. In the drawings, like numerals describe substantially similar components throughout the several views. These embodiments are described in sufficient detail to enable those skilled in the art to practice the invention. Other embodiments may be utilized and structural or other changes may be made without departing from the scope of the present invention.

[0014] Referring now to FIGS. 1-3 and 6, there is illustrated an example embodiment of modular office furniture according to the inventive subject matter disclosed herein. A circular modular office furniture arrangement 100 includes three workstation areas 110. Areas 110 are separated by partition walls 120. Partition walls 120 are disposed radially from a center column member 130. Shelves 140 are mounted to the column member 130 and the partition walls 120. A cabinet 150 is also mounted to column member 130 and partition walls 120, and includes a pair of doors 155 and a top 156. A desk (or table) 160 having a work-surface 165 is positioned with an outer edge extending along a circumference 170 of the arrangement 110. Modular desk-top organizers 180 may be positioned on the work-surface 165, or stacked. In one example embodiment, the organizers 180 may include sound insulation foam placed inside them to help minimize ambient and work related sound.

[0015] Referring to FIG. 6, the frame system 200 for the arrangement 100 is illustrated. Floor-stand components include three base members 210, each with a V-shaped end 215 adapted to abut one another at the center point of the frame system 200. In one embodiment, members 210 may be formed of milled metal. Base members 210 are fastened together using a circular collar member 230, which includes three legs 235 that fit between the base members 210 and are sized to extend to the floor underneath the frame. A plurality of through-holes are provided in collar member 230 to extend from the top of the member 230 down into corresponding holes in the base members 210 to allow for the members to be bolted together with nuts and washers on the underside of the members 210, which may include a recess for the same. In addition, in one example embodiment, the frame 200 includes three track members 224 which are joined at an inner end to respective ones of base members 210 and on an outer end to respective ones of arcuate wiring conduits 226 adapted to cover wiring running from the inside of track members 224 through conduits 226 to reach underneath the desks 160. Accordingly wiring may be brought safely from an access point inside the perimeter of the arrangement to a location under the desks 160.

[0016] A center frame member 240 that takes the form of a tubular member in one example embodiment, includes three square notches 242 on the bottom end thereof, and has an inside diameter sized to fit over collar member 230. Through-holes are provided on the bottom of frame member 240 to align with corresponding through holes on collar member 230. Fasteners such as bolts may be passed through the corresponding through holes to fasten the collar member 230 to the center frame member 240. Two arcuate floor mount brack-

ets are further provided and may be fastened to the floor between two of the base members 210. Mounting plates 260 are inserted into corresponding slots 212 in base members 210, and include transverse through-holes arranged to align with corresponding transverse through-holes on base members 210. Fasteners, such as but limited to bolts, may be inserted through the base members 210 and plates 260 to secure them in place.

[0017] According to one example embodiment, partition walls 120 include a slot or recess 122 on the bottom 124 thereof sized to snugly receive the plates 260 and support the walls 120 in a vertical position. In addition, walls 120 include mounting brackets 124 that are sized to fit into corresponding mounting slots 246 in center frame member 240. During assembly of the arrangement 100, walls 120 may be lifted and slid into place with brackets 124 fitting into mounting slots 246, and the slots 122 slid over the mounting plates 260. Shelves 140 include mounting pins or dowels 142 sized to fit snugly into corresponding mounting holes 125 in walls 120 and center frame member 240. Each side of cabinet 150 is mounted to the walls 120 using two door frame members 156 that include hinges 157 connected to doors 155. Top and bottom members of cabinet 150 each include mounting pins or dowels and is mounted to walls 120 and center frame member 240 in the same manner as the shelves 140. Desk 160 may be assembled by fastening the work-surface 165 to a front side 167 and to leg members 168. Modular desk-top organizers 180 may be assembled by fastening top 182, side 184 and front 186 members together, using any suitable fastening system. In one example embodiment, work surface 165 and organizer top 182 include holes through which computer or electrical wiring may be fed.

[0018] According to still another example embodiment, the partition walls 120 include a pocket 127 to receive a sliding partition member 300 which includes wheels or rollers 310 on the bottom thereof to slide in a guide channel 320 formed in base members 210 and track members 224. Sliding partition members 300 may thus be slid or rolled between a stowed position substantially inside the pocket 127 and a fully or partially deployed position. When fully deployed, the sliding partition member 300 may extend to the end of a track member 224, to provide more privacy for an occupant of workstation area 110.

[0019] Referring now to FIGS. 4, there is illustrated an alternate example embodiment 400 of the modular arrangement described with respect to FIGS. 1-10, with the inclusion of a raised floor 400. Raised floor 400 includes a plurality of floor members 410 supported on floor support frame members 420 that may be assembled with fasteners or otherwise fastened together by any suitable means. Frame members 420 include at least one unobstructed path 430 from the inner end 440 of the frame to an outer end 450, to allow for wiring to pass under the floor members 410. In one embodiment, floor members 410 are pie-shaped, but other shapes may be used. Although the embodiment of FIG. 4 includes a raised floor, not all embodiments include a raised floor.

[0020] Referring now to FIG. 5, there is illustrated still other example embodiments wherein lighting fixtures or other devices are mounted in a center mounting tower 500. Tower 500 may include a circular frame structure 510 supporting a plurality of lighting fixtures 520 that may include lighting elements 530 such as fluorescent bulbs. A plurality of

translucent lenses 540 are provided to cover the lighting elements, and may be snap fit into place on the frame 510 or otherwise fastened in place.

[0021] Referring to FIGS. 7-20, there are illustrated various other views of the embodiments of the inventive subject matter including alternate views of the embodiments described above.

[0022] FIG. 21 illustrates a partition wall 2102 with a sliding partition 2106 that slides horizontally. The partition wall 2102 includes a pocket 2104 formed integrally therein. The sliding portion 2106 is operable to slide in and out of the pocket 2104 back and forth in a horizontal direction. The partition wall 2102 also includes a coupling track 2108 or other connection arrangement to connect with other partition walls or other modular office furniture or stationary walls of a structure to form partitioned workspaces, such as cubicles. The partition wall 2102 may be installed to allow a workspace occupant to adjust the workspace size, openness, and privacy.

[0023] FIG. 22 illustrates a partition wall 2202 with a sliding partition 2206 that slides vertically. The partition wall 2202 includes a pocket 2204 formed integrally therein. The sliding portion 2106 is operable to slide up and down in a vertical direction. The partition wall 2202 also includes a coupling track 2208 or other connection arrangement to connect with other partition walls or other modular office furniture or stationary walls of a structure to form partitioned workspaces, such as cubicles. The partition wall 2202 may be installed to allow a workspace occupant to adjust a workspace and sightlines in and out of the workspace for privacy or openness.

[0024] FIG. 23 illustrates a partition wall 2302 with a sliding partition 2306 that slides vertically. The partition wall 2302 includes a vertical portion and a horizontal portion. The horizontal portion includes a pocket formed integrally therein to allow sliding portion 2306 so be moved into and out of sight in a vertical direction. The vertical portion includes a track 2308 that the sliding portion 2306 is guided by. The partition wall 2302 includes a coupling track 2310 or other connection arrangement to connect with other partition walls or other modular office furniture or stationary walls of a structure to form partitioned workspaces, such as cubicles. The partition wall 2302 may be installed to allow a workspace occupant to adjust a workspace and sightlines in and out of the workspace for privacy or openness.

[0025] Thus, as describe above, at least one example embodiment disclosed herein provides a modular office furniture arrangement wherein the arrangement is circular with desks in each workstation area facing toward the outside circumference of the circle and fixed partition walls extend radially outward from a center of the circular arrangement to provide pie-shaped workstation areas. A sliding partition wall may be provided and slide out of a pocket in the fixed partition wall to provide additional portioning of the workstation areas. When the sliding partitions are retracted in the stowed position, the arrangement provides easy access to the adjacent workstation areas, and when fully deployed increase the privacy of the occupant. Further, by placing the desk 160 facing outwardly, the user of the workstation area may enjoy a greater sense of security or comfort as other personnel cannot approach them unexpectedly from the rear.

[0026] According to another example embodiment, the above described parts may be placed into a kit along with instructions for assembly. The kit may be contained in one or more boxes, crates or other container for shipping to the

desired location. According to another example embodiment, the kit further instructions for instructions for assembling the center frame member, the three partition walls and the three desks so that the at least three fixed partition walls extend radially outwardly from the center frame member to partition the assembly into at least three pie-shaped workstation areas, and so that there is at least one desk in each workstation area, wherein the desk has a front portion that faces the circumference of the assembly so that a worker seated at the desk faces away from the center frame member kit.

[0027] According to another example embodiment, various components and members of the furniture arrangement disclosed herein may be formed using aluminum or steel. In one example embodiment, the floor, shelves and desk panels may be made of plywood or laminated particle board. In another embodiment, snap-on wall panels may be made of various fabrics wrapped tightly around aluminum frame. Sound absorbing materials may be used, such as sound absorbing foam or fabric.

[0028] Although specific embodiments have been illustrated and described herein, it will be appreciated by those of ordinary skill in the art that any arrangement which is calculated to achieve the same purpose may be substituted for the specific embodiment shown. This application is intended to cover any adaptations or variations of the present invention. It is to be understood that the above description is intended to be illustrative, and not restrictive. Combinations of the above embodiments, and other embodiments will be apparent to those of skill in the art upon reviewing the above description. The scope of the invention includes any other applications in which the above structures and fabrication methods are used. The scope of the invention should be determined with reference to the appended claims, along with the full scope of equivalents to which such claims are entitled

- 1. Apparatus comprising:
 - a circular assembly having a center frame member and a circumference;
 - at least two fixed partition walls extending radially outwardly from the center frame member to partition the assembly into at least two semi-circular-shaped workstation areas;
 - at least one desk in each workstation area, wherein the desk has a front portion that faces the circumference of the assembly so that a worker seated at the desk faces away from the center frame member.
- 2. Apparatus according to claim 1 further including a sliding partition that extends from a stowed position in a pocket in at least one of the fixed partition walls to a deployed position that is at least partially extended radially outward from the stowed position.
- 3. Apparatus according to claim 1 further including a raised floor extending from the circumference of the assembly to the center.
- 4. Apparatus according to claim 1 further including a lighting fixture assembly extending at least in part upwardly from the center frame member.

5. The apparatus of claim 1, wherein the at least two fixed partition walls include three or more fixed partition walls to partition the assembly into at least three pie-shaped workstation areas.

6. The apparatus of claim 1 further including a sliding partition that raises from a stowed position in a pocket in at least one of the fixed portioned walls to a deployed position that is at least partially extended upward from the stowed position.

7. An office furniture kit comprising:

- a center frame member;
- at least three partition walls adapted to be fastened to the center frame member on an inside end;
- at least three desks each with a arcuate front edge;
- instructions for assembling the center frame member, at least three partition walls, and at least three desks so that the at least three fixed partition walls extend radially outwardly from the center frame member to partition the assembly into at least three pie-shaped workstation areas, and so that there is at least one desk in each workstation area, wherein the desk has a front portion that faces the circumference of the assembly so that a worker seated at the desk faces away from the center frame member.

8. A kit according to claim 7 further including a sliding partition that extends horizontally from a stowed position in a pocket in the fixed partition wall to a deployed position that is at least partially extended radially outward from the stowed position.

9. A kit according to claim 7 further including a sliding partition that raises vertically from a stowed position in a pocket in at least one of the fixed portioned walls to a deployed position that is at least partially extended upward from the stowed position.

10. A kit according to claim 7 further including a raised floor extending from the circumference of the assembly to the center.

11. A kit according to claim 7 further including a lighting fixture assembly extending at least in part upwardly from the center frame member.

12. A modular office furniture partition wall comprising:

- a pocket formed integrally within the modular office furniture partition wall; and
- a sliding partition within the pocket slidable to increase a size of the modular office furniture partition wall.

13. The modular office furniture wall of claim 12, wherein the sliding partition is slidable in a vertical direction.

14. The modular office furniture wall of claim 12, wherein the sliding partition is slidable in a horizontal direction.

15. The modular office furniture wall of claim 12 including a horizontal portion and a vertical portion, wherein:

- the horizontal portion includes the pocket formed integrally therein to house the sliding partition; and
- the vertical portion includes a track extending along a vertical dimension of one side of the vertical portion to guide the sliding portion when deployed vertically from the pocket.

* * * * *