



US00RE48217E

(19) **United States**
(12) **Reissued Patent**
Brekke et al.

(10) **Patent Number:** **US RE48,217 E**
(45) **Date of Reissued Patent:** **Sep. 22, 2020**

(54) **GOLF CLUB**

(71) Applicant: **SUMITOMO RUBBER INDUSTRIES, LTD.**, Kobe (JP)

(72) Inventors: **Dustin J. Brekke**, Fountain Valley, CA (US); **Jeff D. Brunski**, Los Angeles, CA (US); **Matthew R. Daraskavich**, Huntington Beach, CA (US); **Samuel G. Lacey**, Huntington Beach, CA (US); **Nathaniel J. Radcliffe**, Huntington Beach, CA (US); **Brian D. Schielke**, Huntington Beach, CA (US)

(73) Assignee: **SUMITOMO RUBBER INDUSTRIES, LTD.**, Kobe (JP)

(21) Appl. No.: **16/545,314**

(22) Filed: **Aug. 20, 2019**

Related U.S. Patent Documents

Reissue of:

(64) Patent No.: **9,737,769**
Issued: **Aug. 22, 2017**
Appl. No.: **14/597,574**
Filed: **Jan. 15, 2015**

U.S. Applications:

(63) Continuation of application No. 13/541,432, filed on Jul. 3, 2012, now Pat. No. 8,951,142, which is a continuation of application No. 12/711,771, filed on Feb. 24, 2010, now Pat. No. 8,241,139.

(51) **Int. Cl.**
A63B 53/00 (2015.01)
A63B 53/04 (2015.01)
A63B 60/42 (2015.01)
G01B 5/00 (2006.01)

(52) **U.S. Cl.**

CPC **A63B 53/0466** (2013.01); **A63B 60/42** (2015.10); **G01B 5/0023** (2013.01); **A63B 53/00** (2013.01); **A63B 2053/0408** (2013.01)

(58) **Field of Classification Search**

CPC **A63B 53/0466**; **A63B 60/42**; **G01B 5/0023**
See application file for complete search history.

(56) **References Cited**

U.S. PATENT DOCUMENTS

5,608,160 A * 3/1997 Chastonay A63B 60/42
473/292
5,776,008 A * 7/1998 Lundberg A63B 53/10
273/DIG. 23
5,879,241 A * 3/1999 Cook A63B 53/00
473/289

(Continued)

FOREIGN PATENT DOCUMENTS

GB 2425262 A * 10/2006 A63B 53/0466

OTHER PUBLICATIONS

May 25, 2016 Office Action issued in U.S. Appl. No. 14/597,574.
Oct. 31, 2016 Office Action issued in U.S. Appl. No. 14/597,574.
May 18, 2020 Office Action issued in U.S. Appl. No. 16/546,406.

Primary Examiner — David O Reip

(74) *Attorney, Agent, or Firm* — Oliff PLC

(57) **ABSTRACT**

A golf club includes a club head having a volume of greater than about 360 cm³ and a mass less than 200 g. A shaft attachable to the club head has a tip end, a butt end, and a shaft balance point distance, BP_s, as measured from the butt end, of no more than 19 inches. And the golf club has a mass less than 300 g.

11 Claims, 21 Drawing Sheets

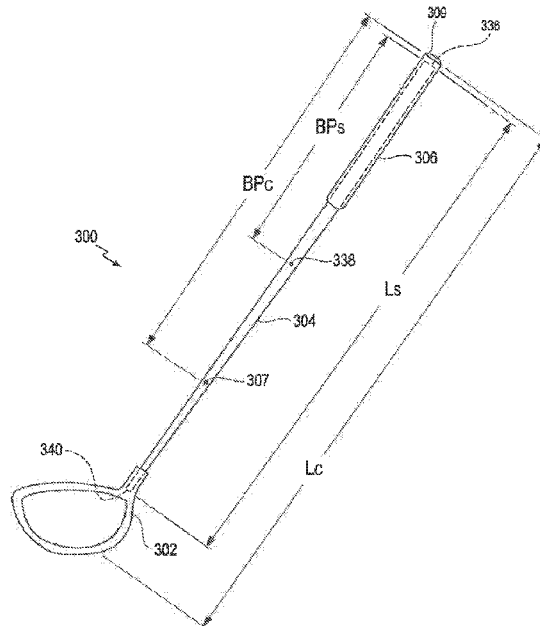

(56)

References Cited

U.S. PATENT DOCUMENTS

6,607,452	B2	8/2003	Helmstetter et al.	
6,767,422	B1	7/2004	Atsumi et al.	
7,326,125	B2 *	2/2008	Moriyama	A63B 53/00 473/292
8,066,583	B2 *	11/2011	Rice	A63B 53/10 473/282
2002/0187853	A1	12/2002	Beach et al.	
2006/0009302	A1 *	1/2006	Oyama	A63B 53/0466 473/282
2007/0004528	A1	1/2007	Hocknell et al.	
2007/0298902	A1	12/2007	Hasegawa	
2010/0041492	A1	2/2010	Rice et al.	

* cited by examiner

FIG. 1

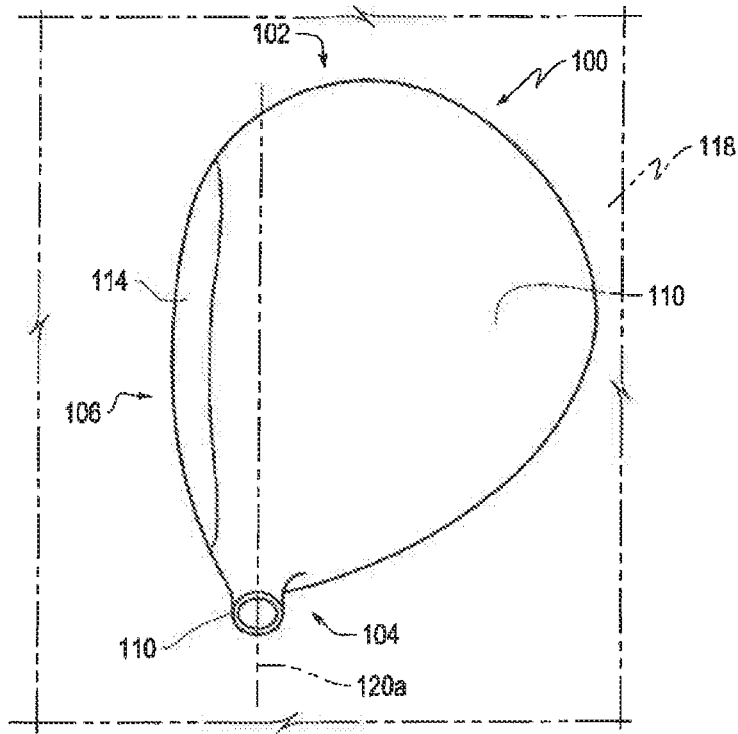
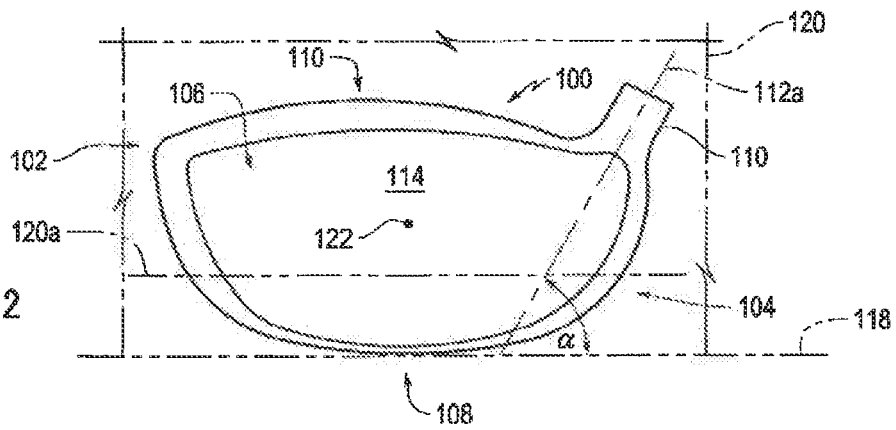
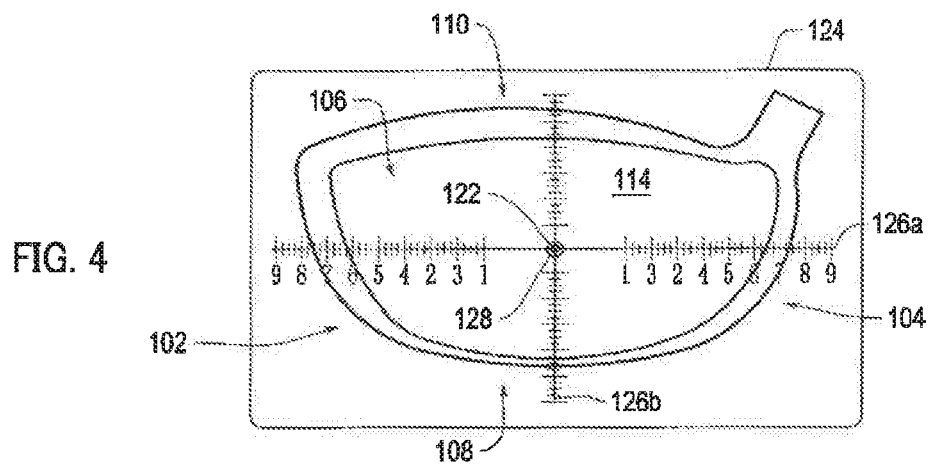
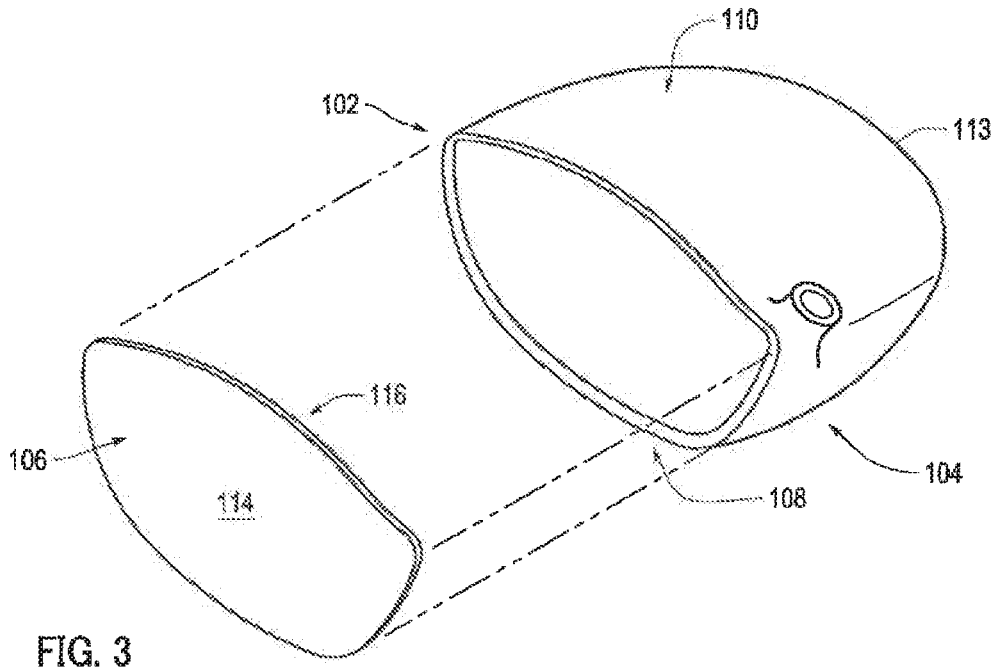
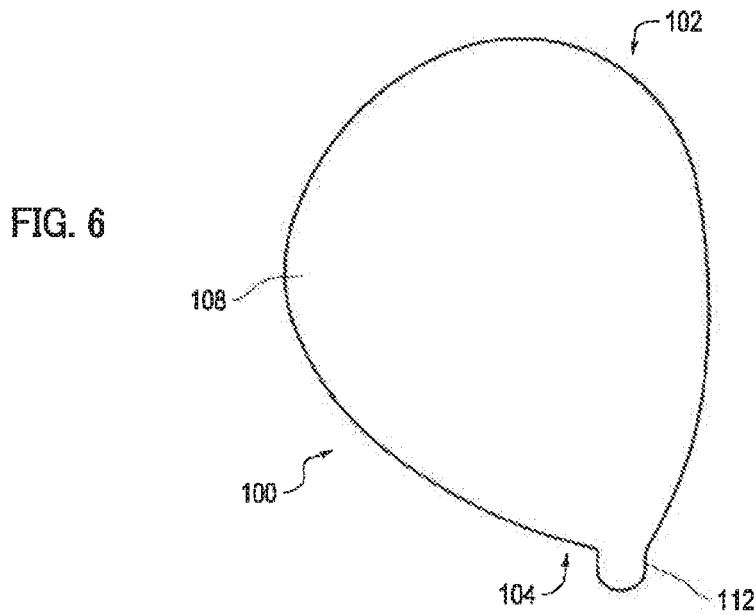
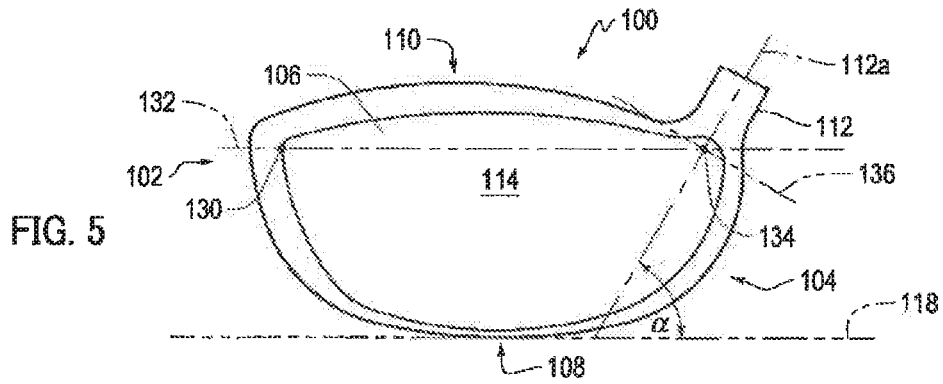

FIG. 2







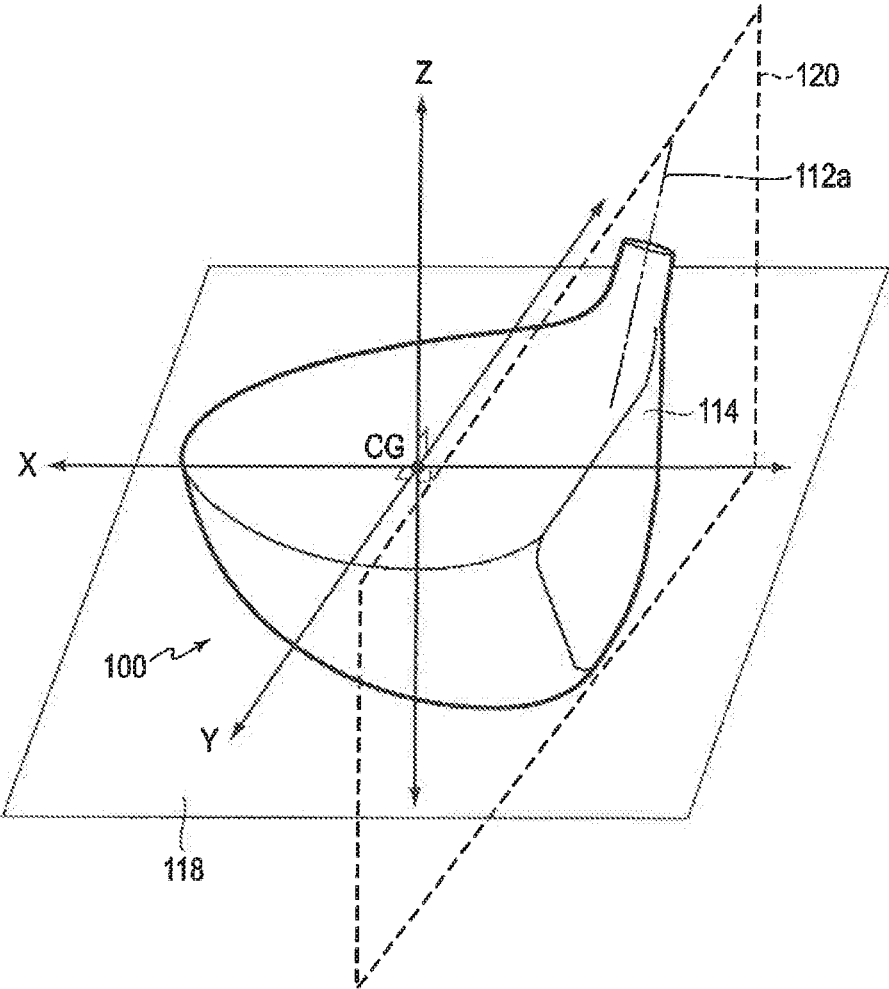

FIG. 7

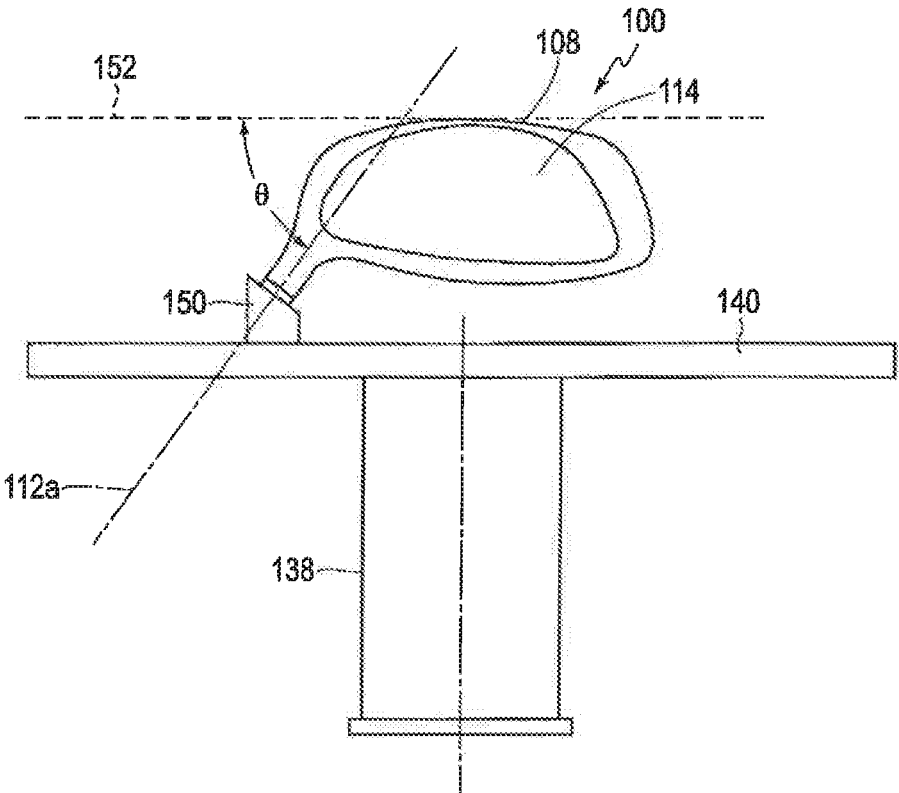

FIG. 8

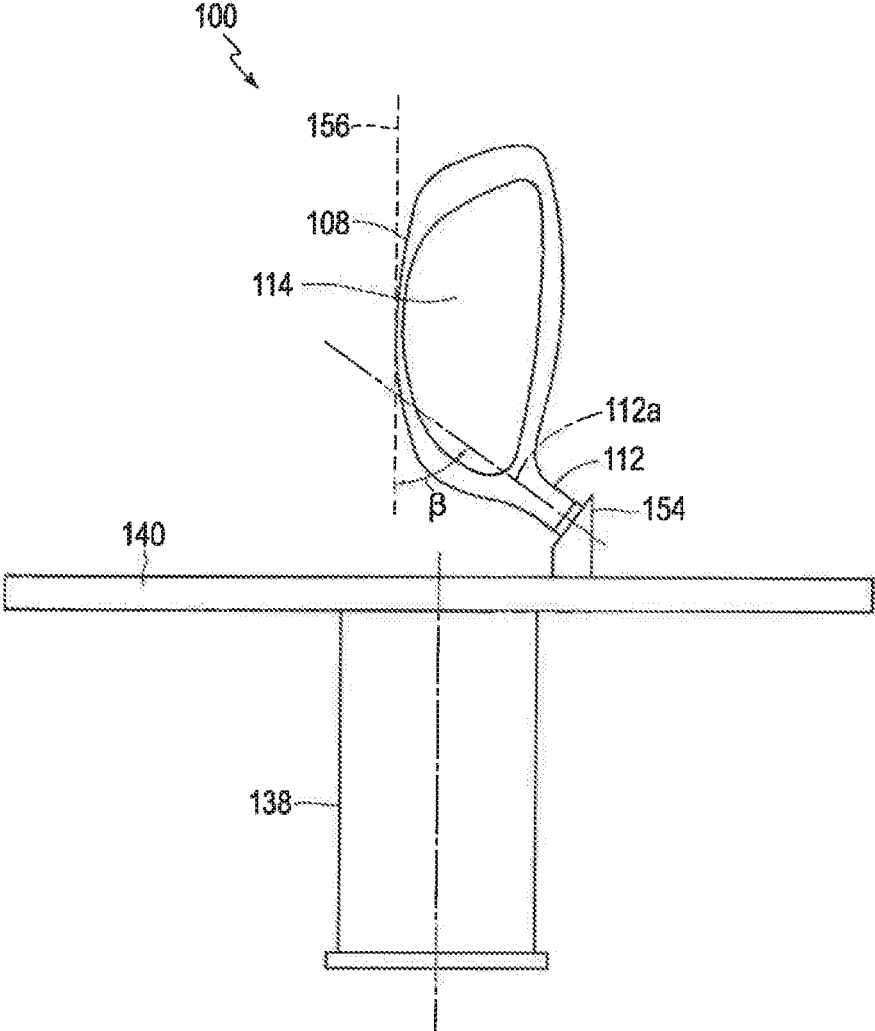

FIG. 9

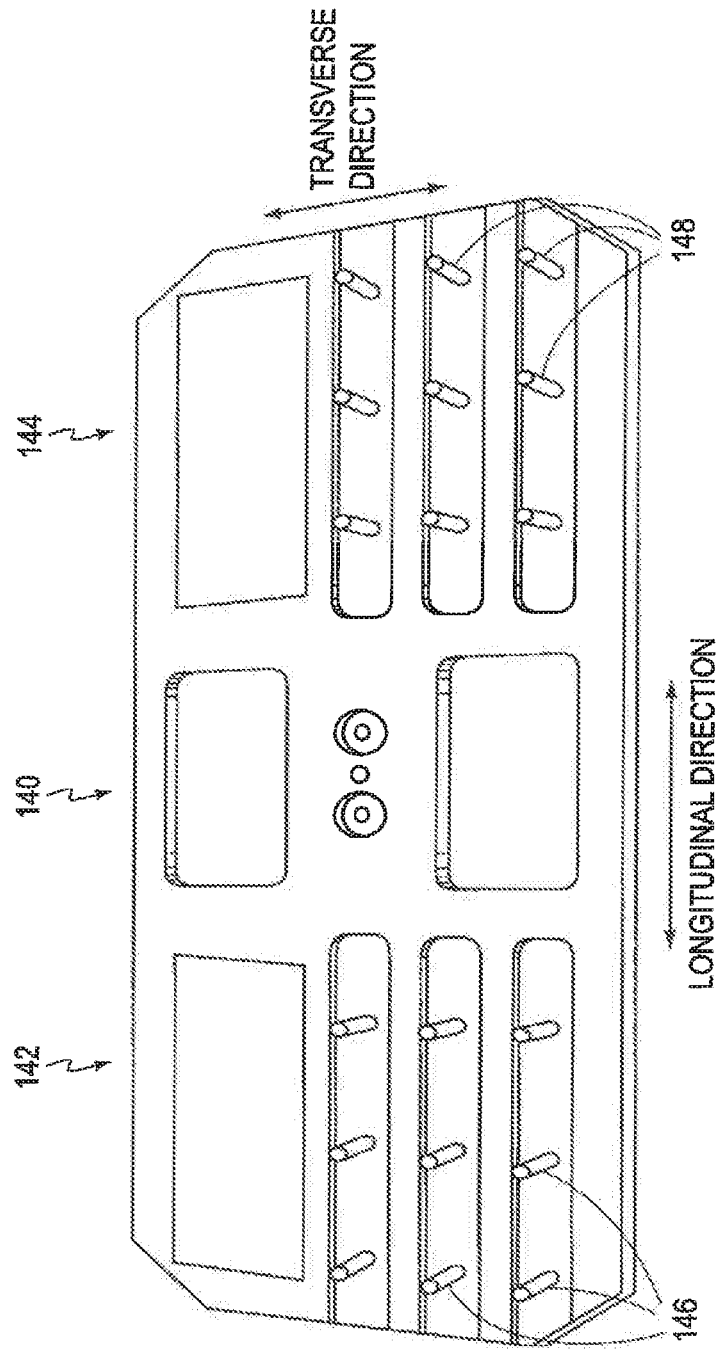

FIG. 10

FIG. 11

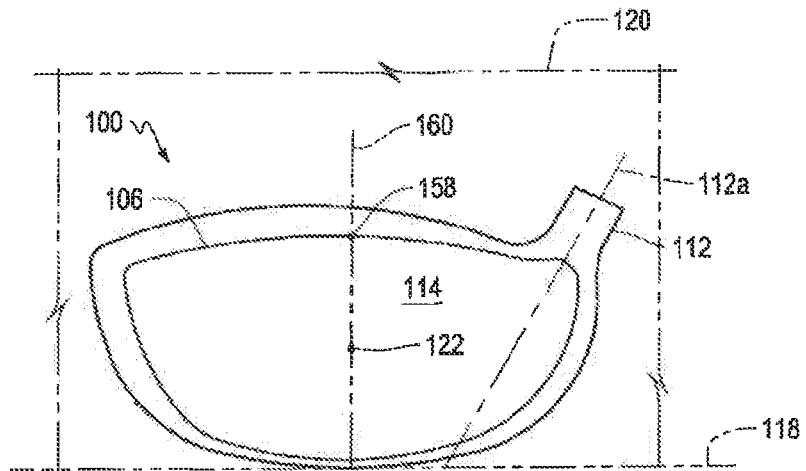

FIG. 12

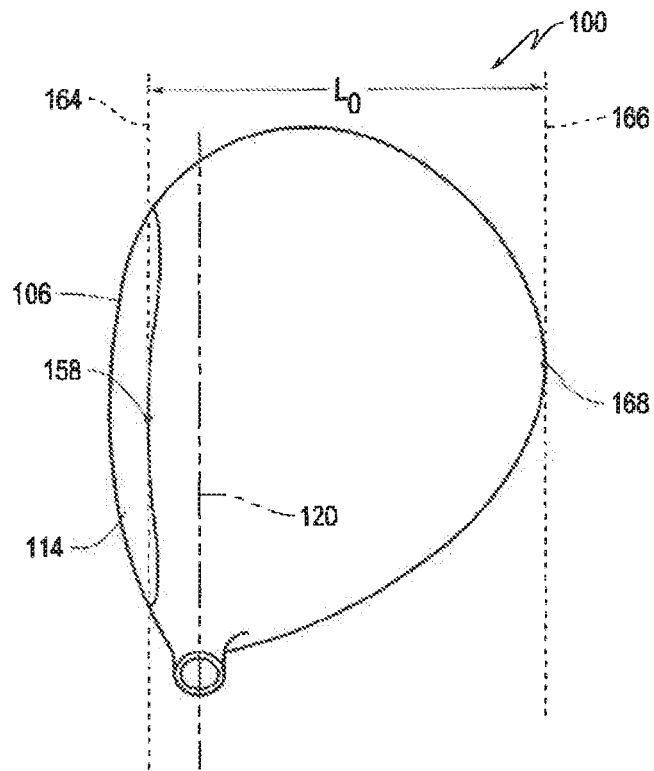
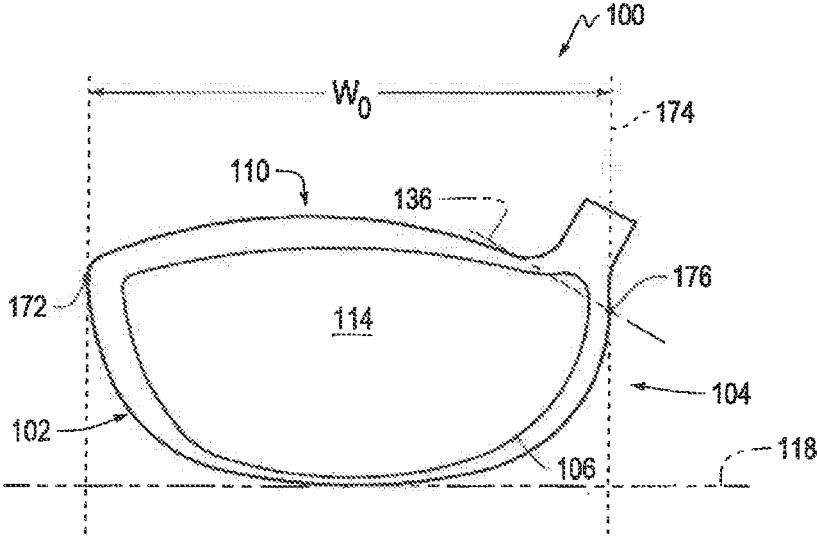

FIG. 13



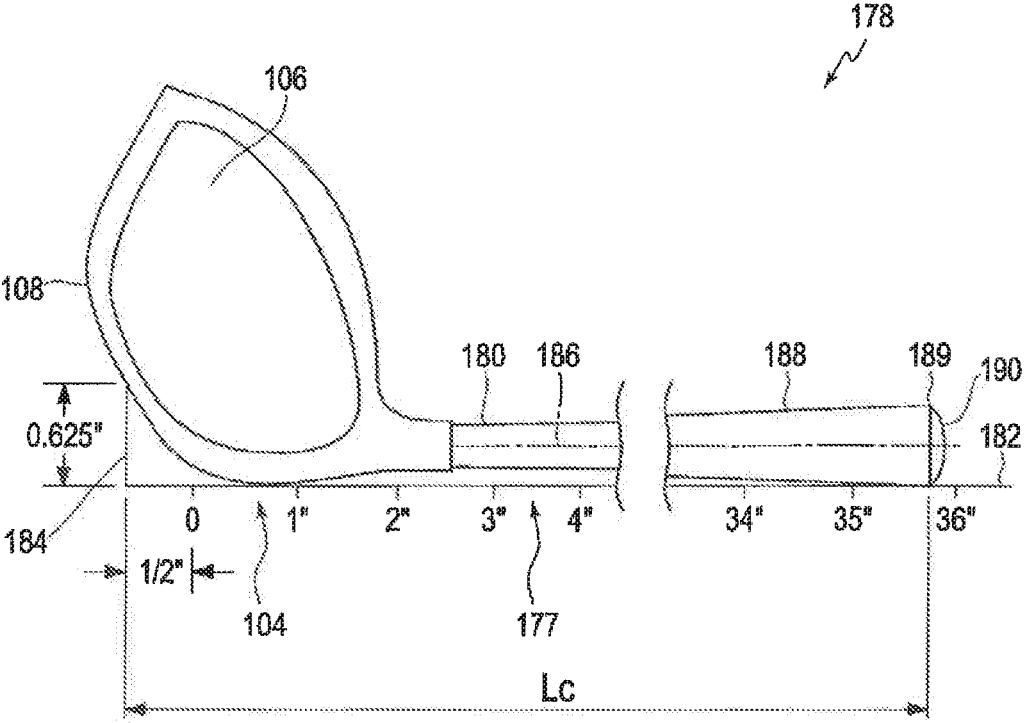

FIG. 14

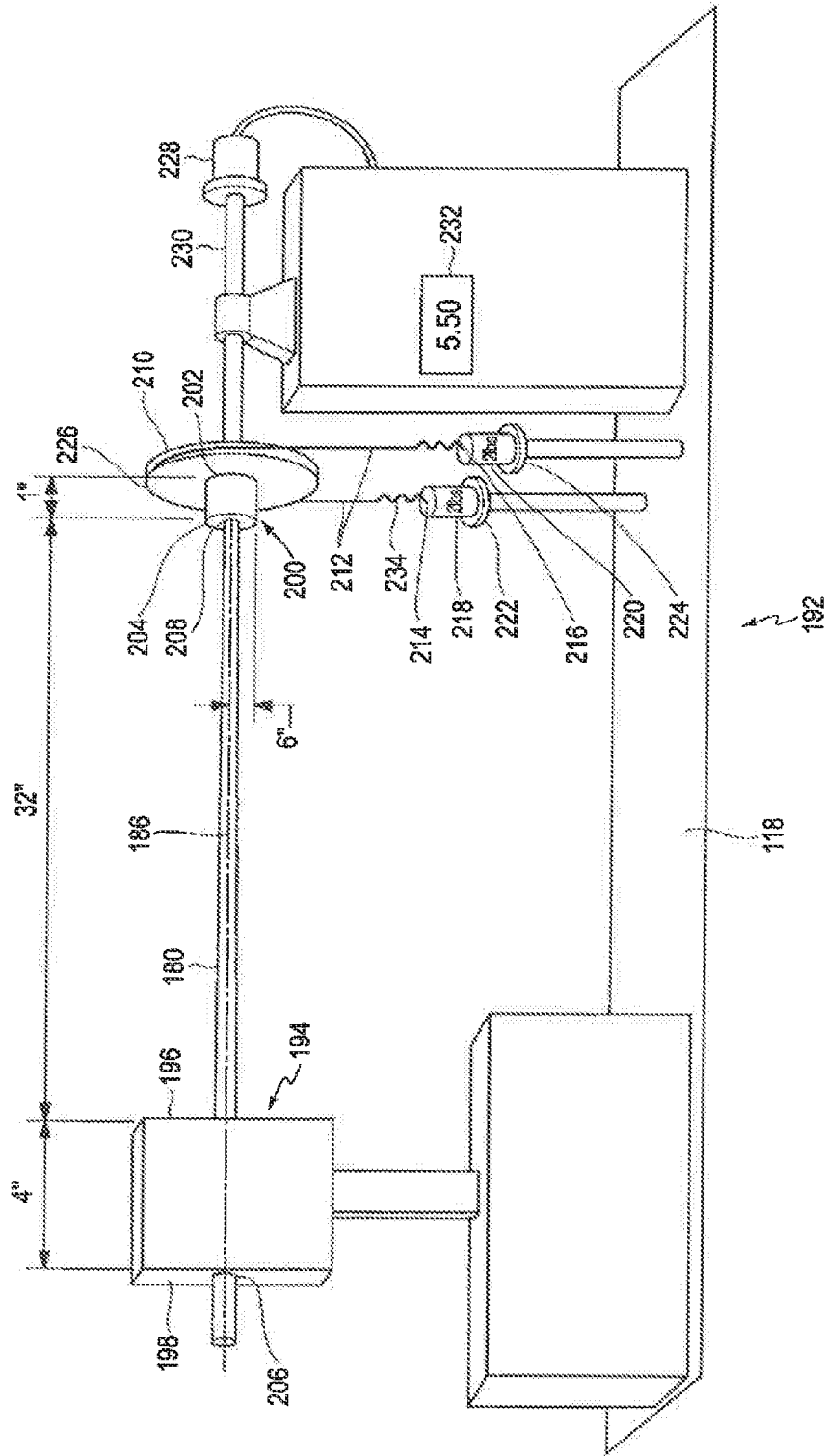

FIG. 15

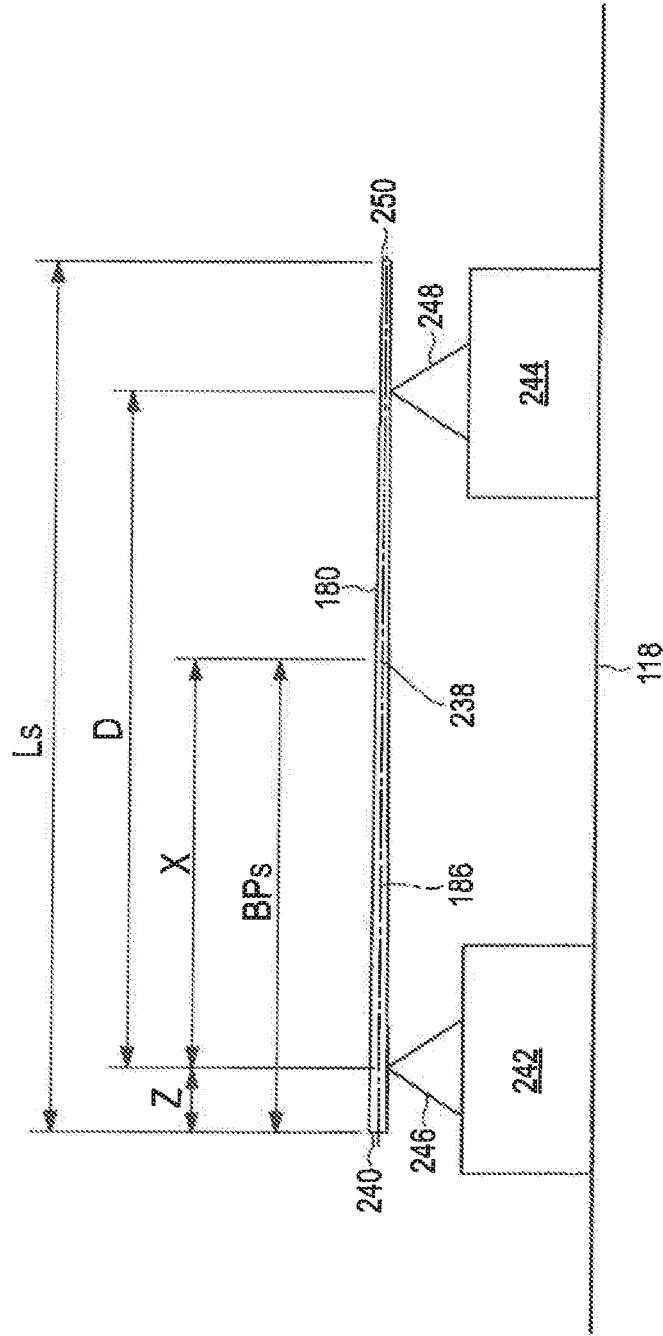

FIG. 16

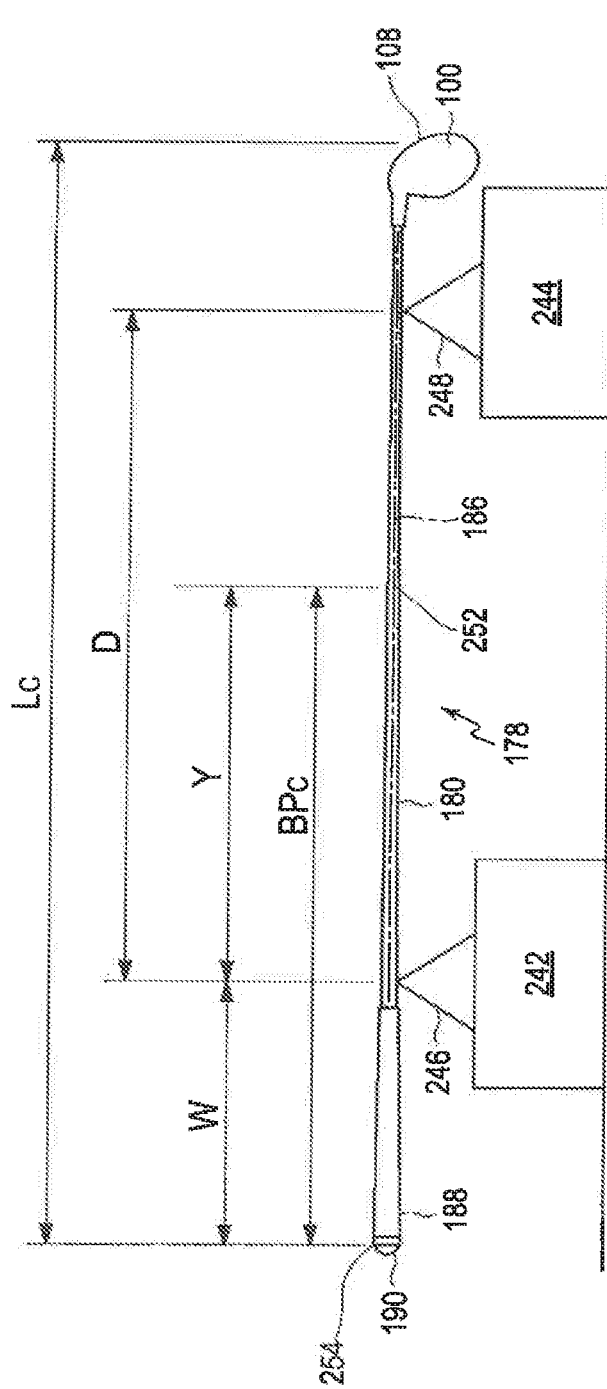

FIG. 17

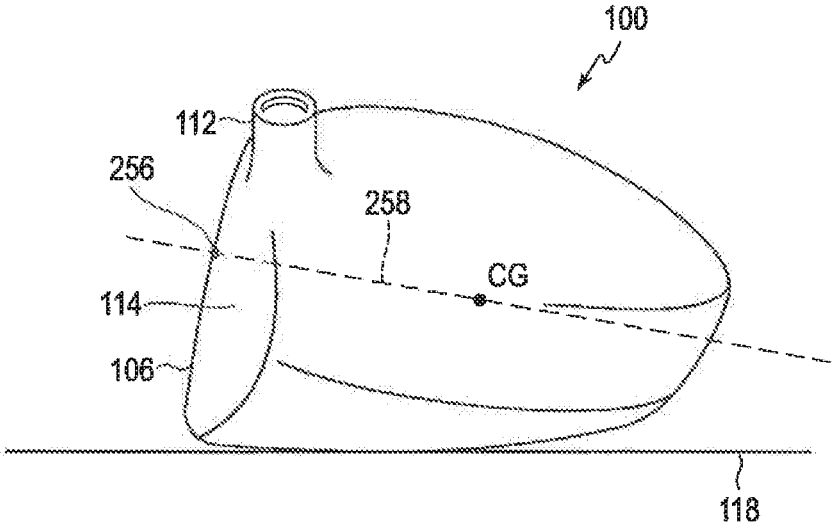

FIG. 18

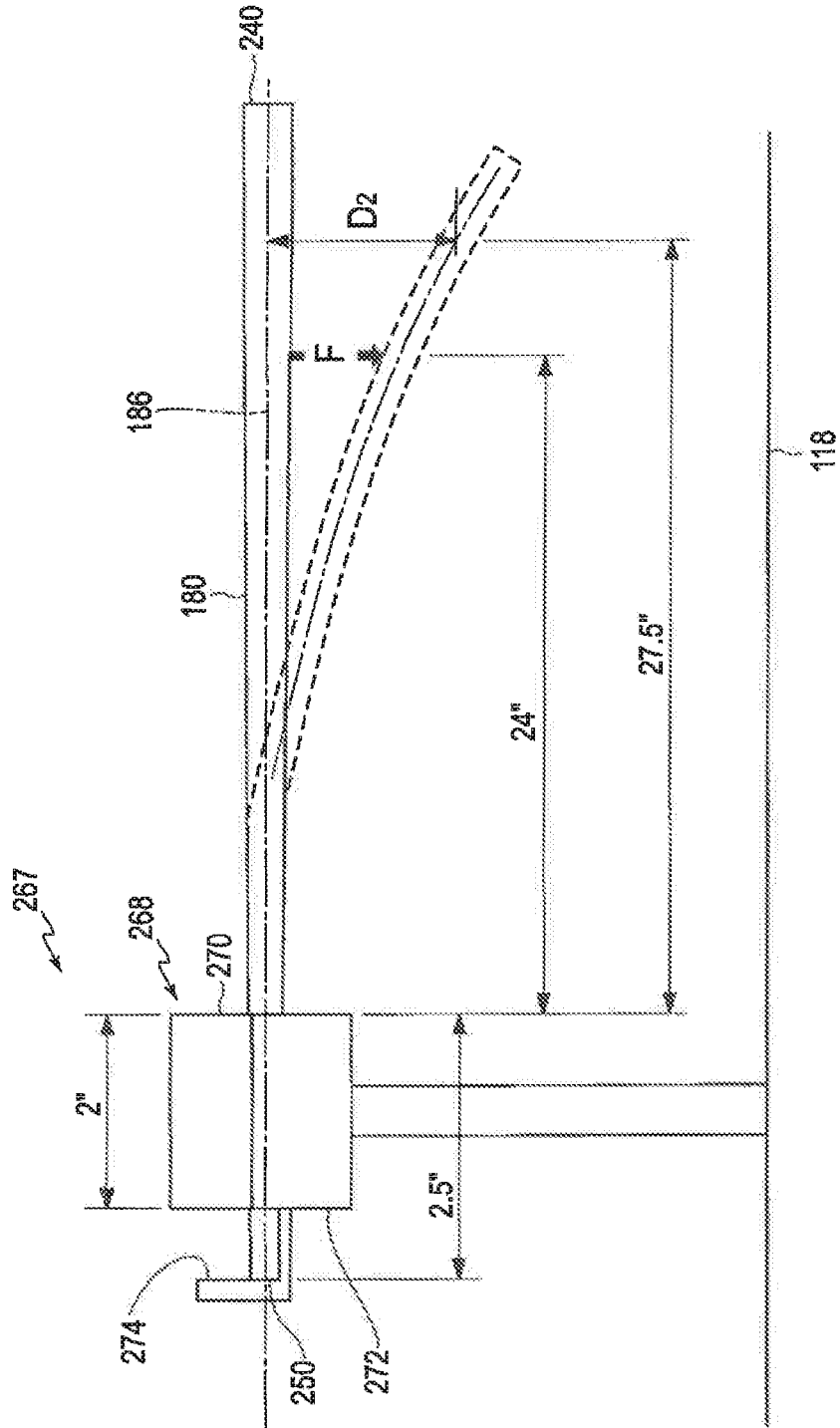

FIG. 20

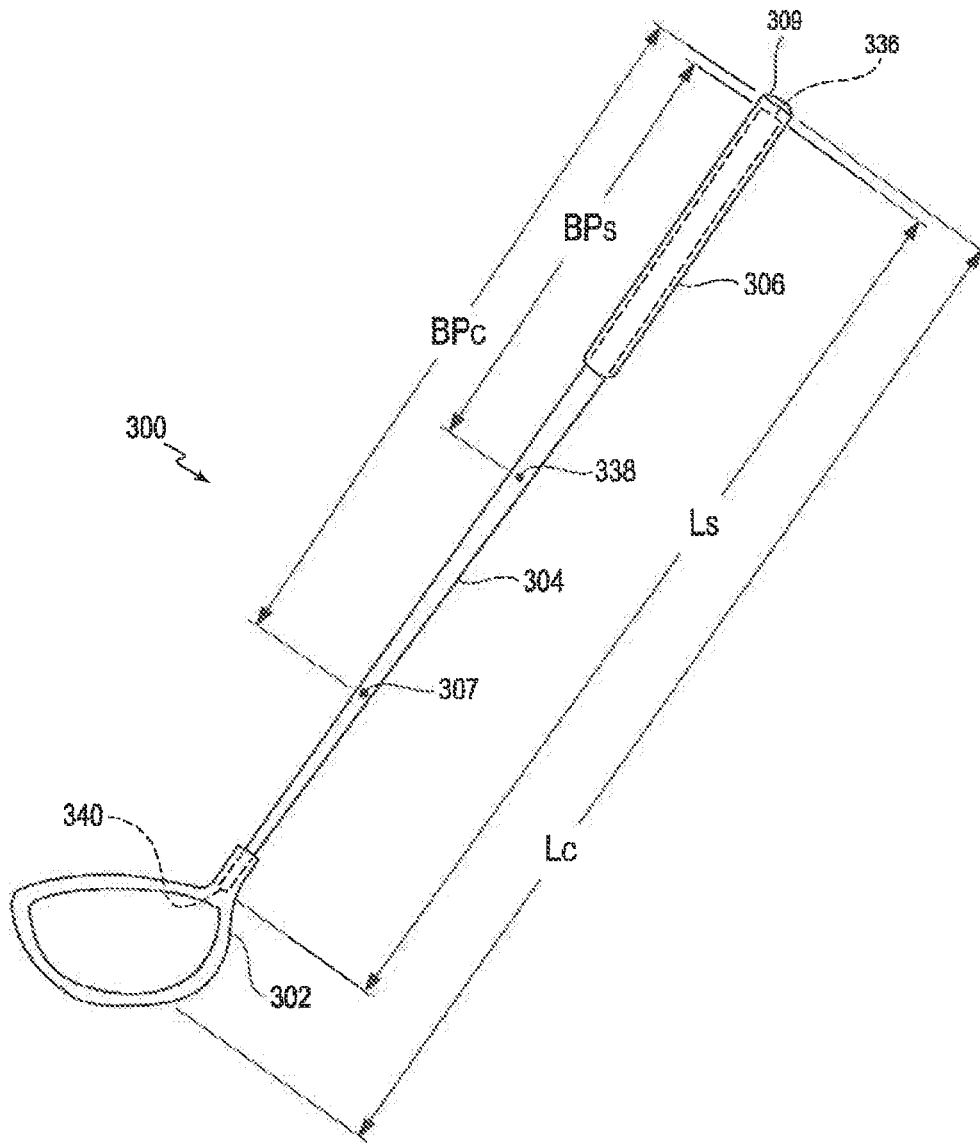

FIG. 21

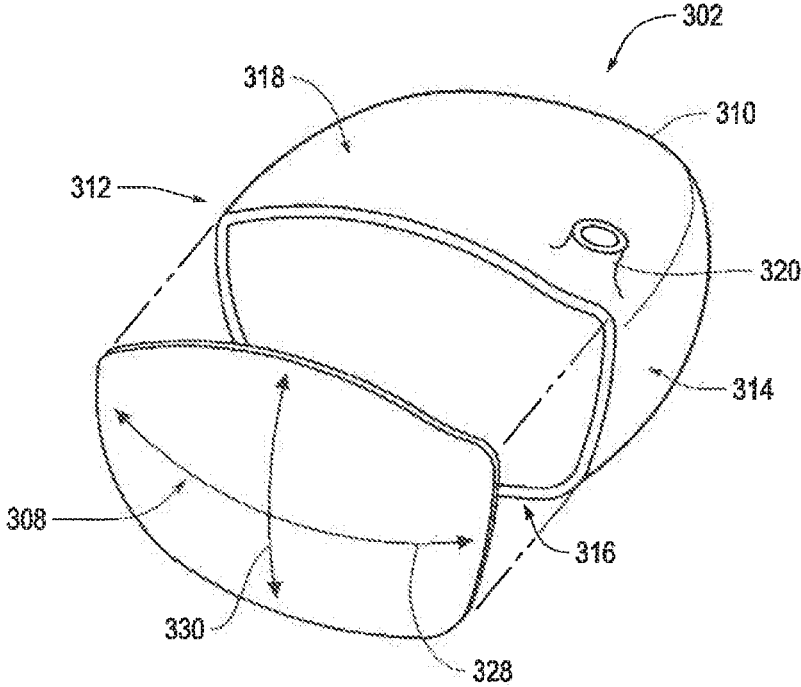

FIG. 22

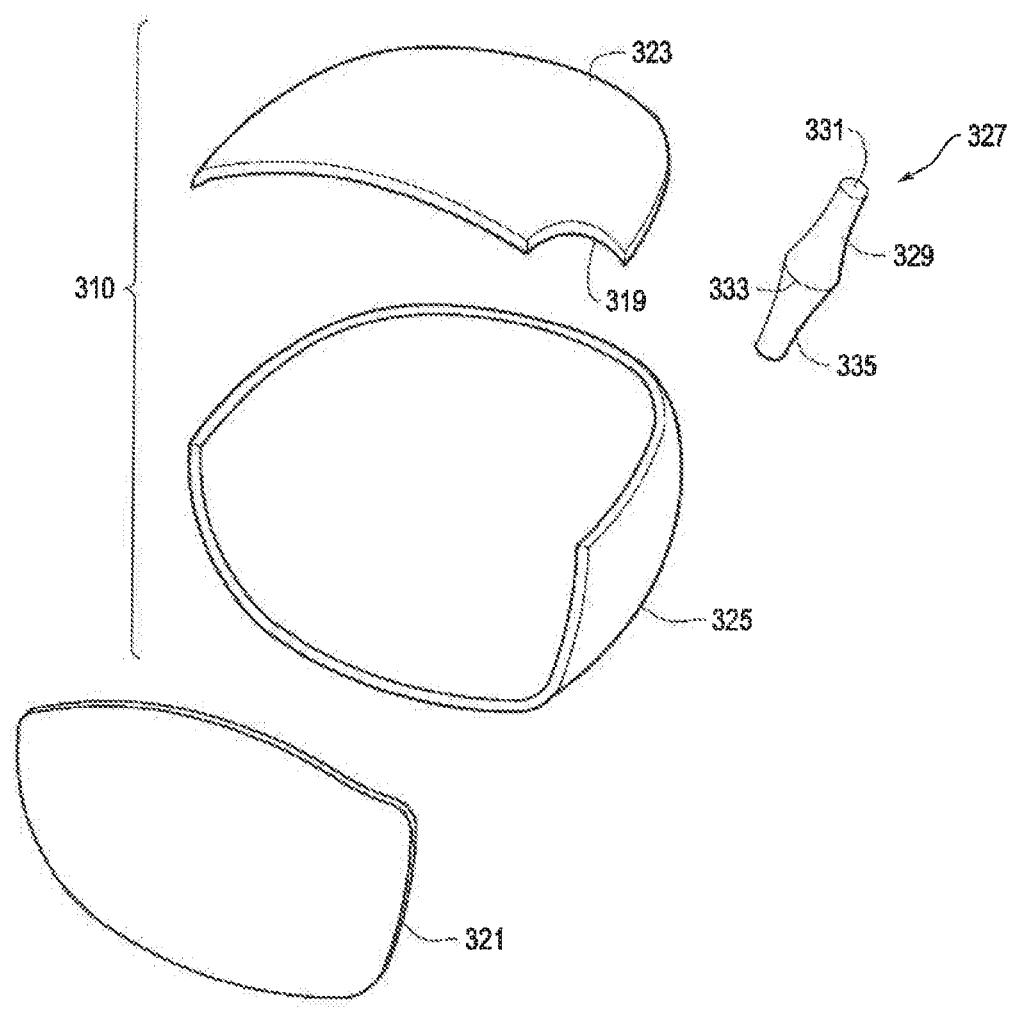

FIG. 23

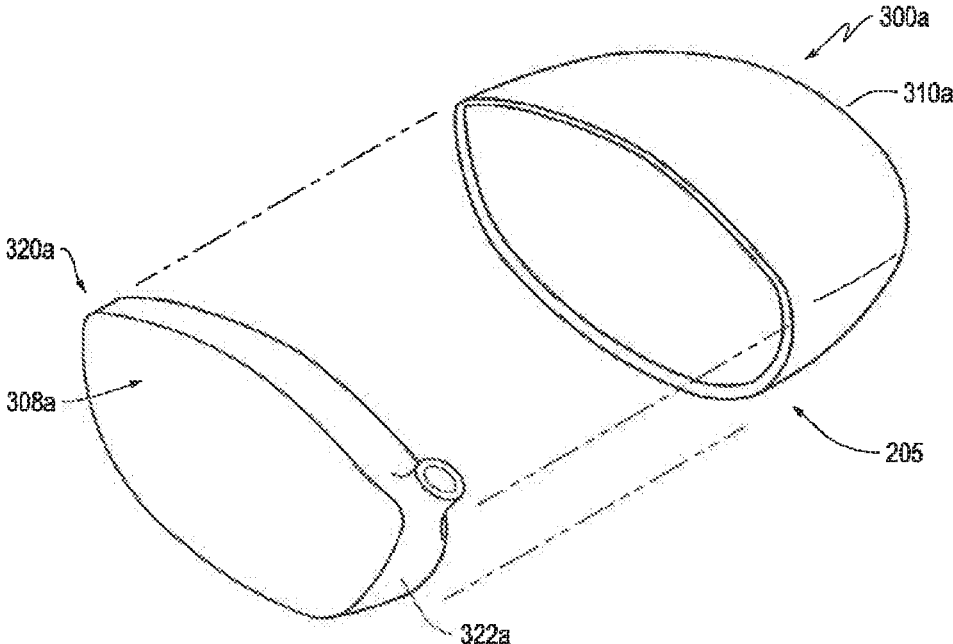

FIG. 24A

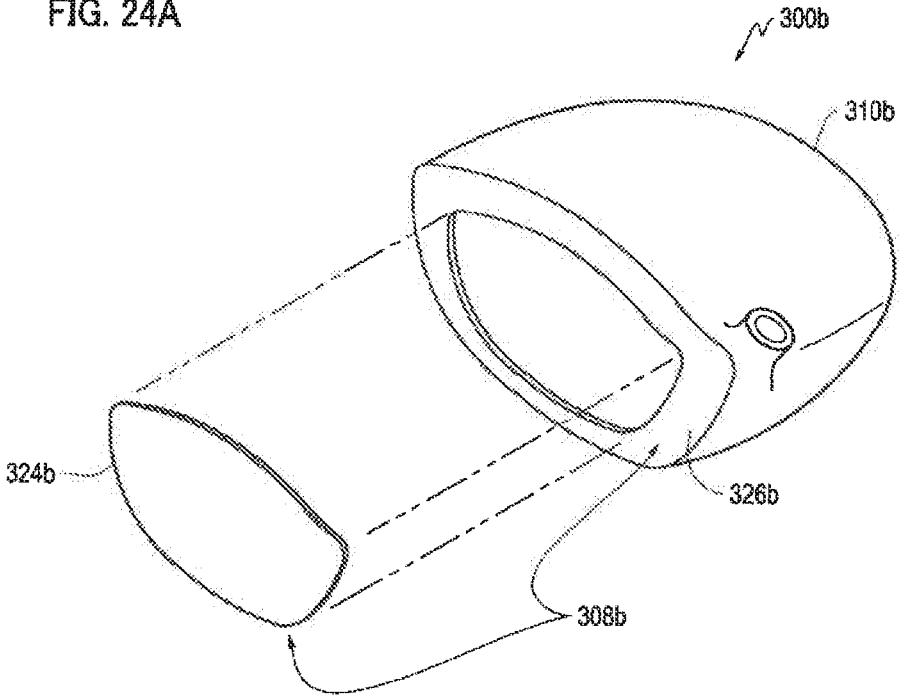

FIG. 24B

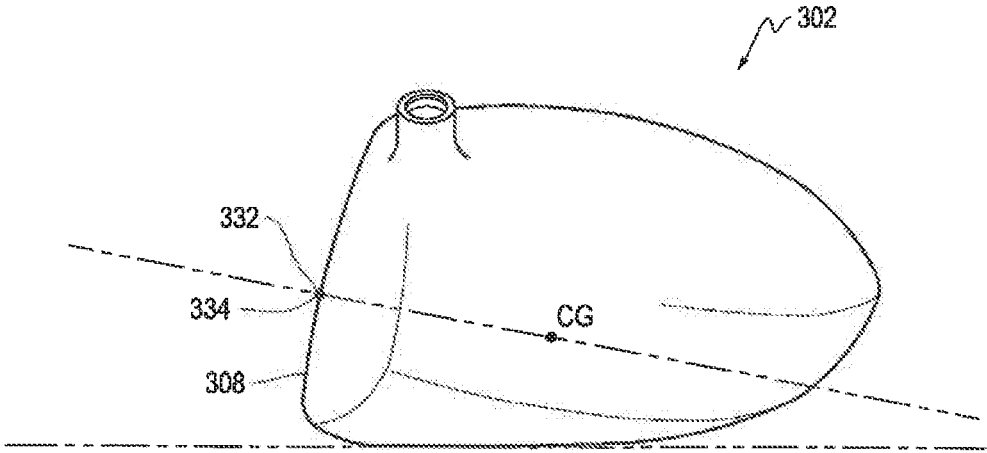

FIG. 25

1

GOLF CLUB

Matter enclosed in heavy brackets [] appears in the original patent but forms no part of this reissue specification; matter printed in italics indicates the additions made by reissue; a claim printed with strikethrough indicates that the claim was canceled, disclaimed, or held invalid by a prior post-patent action or proceeding.

CROSS-REFERENCE TO PRIOR APPLICATIONS

This application is a continuation of U.S. patent application Ser. No. 13/541,432, filed on Jul. 3, 2012, which is in turn a continuation of U.S. patent application Ser. No. 12/711,771, filed on Feb. 24, 2010 and issued as U.S. Pat. No. 8,241,139 on Aug. 14, 2012, the disclosures of which are incorporated herein by reference.

COPYRIGHT AUTHORIZATION

The disclosure below may be subject to copyright protection. The copyright owner has no objection to the facsimile reproduction by anyone of the documents containing this disclosure, as they appear in the Patent and Trademark Office records, but otherwise reserves all applicable copyrights.

BACKGROUND

It is generally known to those skilled in the art of golf club making that the travel distance of a struck golf ball is related to the club-head speed (swing speed) generated at ball impact. Attempting to increase the swing speed by simply making the club longer may negatively affect shot accuracy and ball-travel distance. Alternatively, to increase swing speed, some manufacturers have produced golf clubs having a diminished overall weight. However, these clubs generally have lighter shafts that communicate a vague feel to the player, leading to inconsistent shots and a loss of confidence in the equipment.

SUMMARY

The present invention, in one or more aspects thereof, may advantageously comprise a golf club that delivers increased swing speed, augmented forgiveness on off-center shots, improved ball-launch conditions, a solid feel, and greater ball-travel distance.

In one example, a golf club, according to one or more aspects of the present invention, may have a total club mass less than about 300 g, a swing weight between D0 and D6, a club-head mass less than about 200 g, a club-head volume of at least about 360 cm³, a grip mass less than about 50 g, and a shaft having a tip end, a butt end, and a shaft balance point located no more than 24 inches from the butt end.

In another example, a golf club, according to one or more aspects of the present invention, may include a total club mass less than about 300 g; a club-head mass less than about 200 g; a club-head volume greater than about 360 cm³; a shaft having a tip end, a butt end, a shaft balance point located no more than 24 inches from the tip end, and a torsional displacement angle greater than about 5.5°; and an imaginary coordinate system having an origin coincident with the center of gravity of the club head, the coordinate

2

system having an x-axis, a y-axis, and a z-axis, wherein the club head has a moment of inertia about the z-axis of at least about 4500 g·cm².

In another example, a golf club, according to one or more aspects of the present invention, may include a total club mass less than about 300 g; a club length greater than about 45 inches; a club head having a front portion, a top portion, a bottom portion, a mass less than about 200 g, and a volume of at least about 360 cm³; a club balance point located no more than 35 inches from the butt portion of the grip, wherein a ratio of the distance between the club balance-point and the butt portion of the grip to the club length is greater than 0.76; and a shaft having a tip end, a butt end, a shaft length greater than about 44 inches, and a shaft balance point located no more than 24 inches from the butt end, wherein a ratio of the distance between the shaft balance point and the butt end to the shaft length is less than 0.47.

In yet another example, a golf club, according to one or more aspects of the present invention, may include a total club mass less than about 300 g; a swing weight between D0 and about D6; a club head having a volume greater than about 360 cm³, a face bulge between about 12.5 inches and about 16 inches, and a mass less than about 200 g; a shaft having a tip end, a butt end, a shaft balance point located no more than 24 inches from the tip end, and a mass less than about 55 g; a grip having a mass less than about 40 g; and an imaginary coordinate system having an origin coincident with the center of gravity of the club head, the coordinate system having an x-axis, a y-axis, and a z-axis, wherein the head has a moment of inertia about the z-axis of at least about 4500 g·cm².

In yet another example, a golf club, according to one or more aspects of the present invention, may include a total club mass less than about 300 g; a swing weight between D0 and about D6; a club length greater than about 45 inches; a club head having a face center, a sweet spot, a volume greater than about 360 cm³, and a mass less than about 200 g, wherein the sweet spot is substantially coincident with the face center; a shaft having a mass less than about 50 g; a grip having a mass less than about 40 g; and an imaginary coordinate system having an origin coincident with the center of gravity of the club head, the coordinate system having an x-axis, a y-axis, and a z-axis, wherein the club head has a moment of inertia about the z-axis of at least about 4500 g·cm² and a moment of inertia about the y-axis of at least about 3000 g·cm².

In yet another example, a golf club, according to one or more aspects of the present invention, may include a total club mass less than about 300 g; a club length greater than about 45 inches; a club head having a face center, a sweet spot, a volume greater than about 360 cm³, a face bulge between about 12.5 inches and about 16 inches, and a mass less than about 200 g, wherein the sweet spot is substantially coincident with the face center; a shaft having a tip end, a butt end, a shaft balance point located no more than 24 inches from the butt end, and a torsional displacement angle greater than about 5.5°; a grip having a mass less than about 40 g; and an imaginary coordinate system having an origin coincident with the center of gravity of the club head, the coordinate system having an x-axis, a y-axis, and a z-axis, wherein the head has a moment of inertia about the z-axis of at least about 4500 g·cm².

In yet another example, a golf club, according to one or more aspects of the present invention, may include a total club mass less than about 300 g; a swing weight between D0 and D6; a club length greater than about 45 inches; a club head having a tip end, a butt end, a shaft balance point

located no more than 24 inches from the butt end, and a mass less than about 50 g; a grip having a mass less than about 40 g; and an imaginary coordinate system having an origin coincident with the center of gravity of the club head, the coordinate system having an x-axis, a y-axis, and a z-axis, wherein the club head has a moment of inertia about the z-axis of at least about 4500 g·cm² and a moment of inertia about the y-axis of at least about 3000 g·cm².

These and other features and advantages of the golf club according to the invention in its various aspects, as provided by one or more of the examples described in detail below, will become apparent after consideration of the ensuing description, the accompanying drawings, and the appended claims. The accompanying drawings are for illustrative purposes only and are not intended to limit the scope of the present invention.

BRIEF DESCRIPTION OF THE DRAWINGS

Exemplary implementations of the present invention will now be described with reference to the accompanying drawings, wherein:

FIG. 1 is a top plan view of an exemplary golf club head according to one or more aspects of the present invention.

FIG. 2 is a front elevational view of the golf club head of FIG. 1.

FIG. 3 is an exploded perspective view of the golf club head of FIG. 1.

FIG. 4 is a front elevational view of the golf club head of FIG. 1, wherein a template is applied to the front portion of the golf club head.

FIG. 5 is a front elevational view of the golf club head of FIG. 1.

FIG. 6 is a bottom plan view of the golf club head of FIG. 1.

FIG. 7 is a toe-side perspective view of the golf club head of FIG. 1.

FIG. 8 illustrates an instrument for measuring the primary moment of inertia of the golf-club head of FIG. 1.

FIG. 9 illustrates an instrument for measuring the secondary moment of inertia of the golf-club head of FIG. 1.

FIG. 10 is a perspective view of a jig plate utilized with the measurement instrument shown in FIGS. 8 and 9.

FIG. 11 is a front elevational view of the golf club head of FIG. 1.

FIG. 12 is a top plan view of the golf club head of FIG. 1.

FIG. 13 is a front elevational view of the golf club head of FIG. 1.

FIG. 14 schematically illustrates a device for measuring the length of an exemplary golf club.

FIG. 15 schematically illustrates an instrument for measuring the torsional displacement angle of an exemplary golf shaft.

FIG. 16 schematically illustrates a device for locating the balance point of an exemplary golf shaft.

FIG. 17 schematically illustrates a device for locating the balance point of an exemplary golf club.

FIG. 18 is a heel-side elevational view of the golf club head of FIG. 1.

FIG. 19 schematically illustrates an apparatus for measuring the stiffness of an exemplary shaft in the butt region.

FIG. 20 schematically illustrates an apparatus for measuring the stiffness of an exemplary shaft in the tip region.

FIG. 21 is a front elevational view of an exemplary golf club, according to one or more aspects of the present invention.

FIG. 22 is an exploded perspective view of an exemplary golf club head, according to one or more aspects of the present invention.

FIG. 23 is an exploded perspective view of an exemplary golf club head, according to one or more aspects of the present invention.

FIG. 24A is an exploded perspective view of an exemplary golf club head, according to one or more aspects of the present invention.

FIG. 24B is an exploded perspective view of an exemplary golf club head, according to one or more aspects of the present invention.

FIG. 25 is a heel-side elevational view of the golf club head of FIG. 22.

DETAILED DESCRIPTION

For clarity, the definitions used herein are interpreted with reference to one or more aspects of the invention characterized in relation to FIGS. 1-23 of the drawings. However, those skilled in the art will appreciate that such definitions also apply to same or similar aspects of the invention described throughout the specification in connection with the remaining drawing figures.

As illustrated in FIGS. 1 and 2, a club head 100 may comprise a toe 102, a heel 104, a front portion 106, a bottom portion 108, a top portion 110, and a hosel 112, having a central axis or centerline 112a.

Referring to FIGS. 1 and 3, "front portion", e.g., the front portion 106, as used herein, denotes a portion of a golf club head at least partially delimited by a generally planar front surface 114, suitable for striking a golf ball, and a rear surface 116. Those skilled in the art will appreciate that even though the front surface 114 is referred to as generally planar, in one or more aspects of the invention it may possess parameters of bulge and roll, customary in a wood-type club. Alternatively, the front surface 114 may be essentially flat, as in an iron-type club.

Referring to FIGS. 1 and 2, "reference position", as used herein, denotes a position of the club head where the hosel centerline 112a is oriented at a lie angle α of 60° with respect to a horizontal ground plane 118 and lies in an imaginary vertical hosel plane 120, which contains an imaginary horizontal line 120a, generally parallel to the front surface 114. Unless otherwise indicated, all parameters herein are specified with the club head in the reference position.

Referring to FIGS. 2 and 4, "face center", e.g., a face center 122, as used herein, is located using a template 124, having a coordinate system with a heel-toe axis 126a orthogonal to a top-bottom axis 126b. An aperture 128 is disposed at the origin of the coordinate system and the axes are graduated into evenly spaced increments. The template 124 may be made of a flexible material, e.g., a transparent polymer.

The location of the face center 122 is determined as follows. The template 124 is initially applied to the front surface 114 so that the aperture 128 is approximately in the middle of the front surface 114 and the heel-toe axis 126a is generally parallel to the line 120a. The template is then translated in the heel-toe direction along the front surface 114 until the heel and the toe measurements along the axis 126a at the opposite edges of the front surface 114 have the same absolute value. Once the template 124 is centered with respect to the front surface 114 in the heel-toe direction, the template is translated in the top-bottom direction along the front surface until the measurements along the axis 126b at the opposite edges of the front surface 114 have the same

absolute value. The above sequence is repeated until the absolute value of the heel measurement along axis **126a** is equal to that of the toe measurement and the absolute value of the bottom measurement along axis **126b** is equal to that of the top measurement. A point is then marked on the front surface through the aperture **128** to designate the face center **122**.

A locating template, such as the template **124**, is referenced in the United States Golf Association's Procedure for Measuring the Flexibility of a Golf Clubhead (Revision 2.0, Mar. 25, 2005) and is available from the USGA.

Referring to FIG. 5, "front toe point", e.g., an outer toe point **130**, as used herein, denotes the furthest laterally projecting point of the front surface **114** proximate the toe **102**. An imaginary horizontal plane **132**, passing through the outer toe point **130**, will intersect the hosel centerline **112a** at the point **134**. "Hosel", e.g., the hosel **112**, as used herein, denotes a portion of the club head delimited from the rest of the head by an imaginary plane **136**, normal to the hosel centerline **112a** and containing the point **134**.

Referring to FIG. 1, "top portion", e.g., the top portion **110**, as used herein, denotes the portion of the club head, excluding the front portion **106** and the hosel **112**, visible in a top plan view with the club head in the reference position.

Referring to FIG. 6, "bottom portion", e.g., the bottom portion **108**, as used herein, denotes the portion of the club head, excluding the hosel **112**, visible in a bottom plan view with the club head in the reference position.

FIG. 7 illustrates an imaginary three-dimensional Cartesian coordinate system, having axes x , y , and z , with its origin at the center of gravity CG of the club head **100**, oriented in the reference position. The z -axis is vertical and is parallel to the hosel plane **120**, containing the hosel centerline **112a**. The y -axis is substantially parallel to the hosel plane **120** and is perpendicular to the z -axis. The x -axis is perpendicular to the z -axis and the y -axis.

The moment of inertia I_{zz} about the z -axis (the primary MOI) and the moment of inertia I_{yy} about the y -axis (the secondary MOI) of the club head **100** may be found using the general methodology disclosed in the Procedure for Measuring the Moment of Inertia of Golf Clubheads, Revision 1.0 (Apr. 12, 2006), as specified by the United States Golf Association (USGA) and R&A Rules Limited (R&A), with procedural modifications for measuring I_{yy} discussed below. The USGA Procedure for Measuring the Moment of Inertia of Golf Clubheads and the associated "USGA MOI Calculation.xls" program are herein incorporated by reference in their entirety.

As described in the USGA Procedure for Measuring the Moment of Inertia of Golf Clubheads, a measuring instrument **138** (see FIGS. 8 and 9), e.g., the Moment of Inertia Instrument (Model #MOI-005-104), available from Inertia Dynamics, Inc. of New Hartford, Conn., designed for measuring the moment of inertia of test parts having mass properties and overall dimensions similar to that of a golf club head, may be used to obtain the moment of inertia I_{zz} about the z -axis and the moment of inertia I_{yy} about the y -axis of the golf club head **100**. Referring once again to FIGS. 8 and 9, a horizontal jig plate **140**, described in the USGA Procedure for Measuring the Moment of Inertia of Golf Clubheads, is attached to the measuring instrument **138**, such that the jig plate and the measurement instrument are level.

As shown in FIG. 10, the jig plate **140** has a first side **142** and a second side **144**. The first side **142** includes mounting pins **146** and the second side **144** includes mounting pins **148**. Pins **146** and **148** comprise rows arranged longitudinally with respect to the jig plate and columns arranged transversely with respect to the jig plate.

nally with respect to the jig plate and columns arranged transversely with respect to the jig plate.

For purposes of measuring the primary MOI of the club head **100**, an adapter **150** (FIG. 8) is utilized to orient the club head with respect to the jig plate **140** so that the bottom portion **108** of the club head is facing up and the club head **100** is disposed such that the angle θ between the hosel centerline **112a** and an imaginary horizontal plane **152** is substantially 60° . Furthermore, the front surface **114** of the club head is substantially parallel to the longitudinal rows of mounting pins **146** and **148**. For purposes of measuring the primary MOI of the club head **100**, the pins **146** on the first side **142** of the jig plate **140** are used for right-handed club heads and the pins **148** on the second side **144** of the jig plate **140** are used for left-handed club heads.

For purposes of measuring the secondary MOI of the club head **100**, an adapter **154** (FIG. 9) is utilized to orient the club head with respect to the jig plate **140** so that the bottom portion **108** of the club head is substantially vertical. In other words, the club head **100** is disposed with respect to the jig plate **140** such that the angle β between the hosel centerline **112a** and an imaginary vertical plane **156** is substantially 60° .

Furthermore, as provided in the USGA Procedure for Measuring the Moment of Inertia of Golf Clubheads, the front surface **114** of the club head is substantially parallel to the longitudinal rows of mounting pins **146** and **148**. For purposes of measuring the secondary MOI of the club head **100**, the pins **146** on the first side **142** of the jig plate **140** are used for left-handed club heads and the pins **148** on the second side **144** of the jig plate **140** are used for right-handed club heads.

Referring to FIG. 11, "center apex", e.g., the center apex **158**, as used herein, refers to a point of intersection between an imaginary vertical plane **160** and the top of the front surface **114**, with the club head **100** in the reference position. The plane **160** is oriented substantially perpendicular to the hosel plane **120**, containing the hosel axis **112a**, and passes through the face center **122**.

Referring to FIG. 12, "overall length", e.g., the overall length L_o , as used herein, denotes the shortest horizontal distance between a first imaginary vertical plane **164**, substantially parallel to the hosel plane **120** and passing through the center apex **158**, and a second imaginary vertical plane **166**, that is parallel to the plane **164** and passes through the furthest rearwardly projecting point **168** of the club head **100** in the reference position, opposite the front surface **114**.

Referring to FIG. 13, "overall width", e.g., the overall width W_o , as used herein, denotes the shortest horizontal distance between a first imaginary vertical plane **170**, substantially perpendicular to the hosel plane **120** (see, e.g., FIG. 11) and passing through the furthest laterally projecting point **172** of the toe **102**, and a second imaginary vertical plane **174** that is substantially perpendicular to the hosel plane **120** and passes through the furthest laterally projecting point **176** of the heel **104**, lying in the imaginary plane **136**, described with reference to FIG. 5 above.

A measurement device **177**, schematically illustrated in FIG. 14, is utilized for the purposes of determining the overall length L_o of a golf club **178**, having a shaft **180**. The measurement device **177** comprises a linear measurement scale **182**, graduated, e.g., in inches, and a stop **184**, perpendicular thereto. The stop **184** has a height of approximately 0.625 inches relative to the linear measurement scale and is spaced substantially 0.500 inches in the negative direction from the origin of the linear measurement scale.

To measure club length, the golf club **178** is oriented relative to the measurement device **177** so that, when the linear measurement scale **182** is in a horizontal plane, with the stop **184** projecting vertically upward, the heel **104** and the grip **188** of the golf club are resting on the linear measurement scale **182**, the face portion **106** of the club head is generally vertically oriented, the bottom portion **108** of the club head rests against the stop **184**, and the shaft axis **186** of the golf club is substantially parallel to the linear measurement scale **182**. Once the golf club **178** is properly oriented relative to the measurement device **177**, the club length is read from the linear scale at the edge **189** of the grip cap. Those skilled in the art will appreciate that the length of the grip dome **190** is not included in the club-length measurement.

A measurement instrument **192**, illustrated in FIG. **15**, is utilized for the purpose of determining the torsional displacement angle of the golf club shaft **180**. The measurement instrument **192** comprises a shaft-butt clamp **194**, having a forward surface **196** and a rearward surface **198**, laterally spaced a horizontal distance of 4 inches from the forward surface **196**, and a tip clamp **200**, having a forward surface **202** and a rearward surface **204**, laterally spaced a horizontal distance of 1 inch from the forward surface **202**. The forward surface **196** of the butt clamp **194** is laterally spaced a horizontal distance of 32 inches from the rearward surface **204** of the tip clamp **200**. The butt clamp **194** and the tip clamp **200** include shaft-retaining openings **206** and **208**, respectively, coaxial with the shaft axis **186**. A torque wheel **210**, having a 6 inch ($\frac{1}{2}$ ft) radius, is co-axial with the shaft axis **186** and is fixed to the tip clamp **200**. The torque wheel has a tether **212** secured to the torque wheel **210** using a locking pin **226**. The tether comprises opposing ends **214** and **216**, coupled to mass elements **218** and **220**, respectively, each weighing 2 lb. The mass elements are disposed on support members, e.g., support members **222** and **224**. The opposing ends **214** and **216** of the tether include slack **234** and **236**, respectively. The torque wheel **210** pivots an inclinometer **228**, e.g., the Accustar® I Inclinometer available from Measurement Specialties, Inc. of Hampton, Va., via a rod **230**. The inclinometer is electronically coupled to a readout display **232**, e.g., the Infinity® INFS2 Deflection Meter, available from Newport Electronics, Inc. of Santa Ana, Calif.

The shaft tip is inserted a distance of 1 inch into the shaft-retaining opening **208** of the tip clamp **200**, such that the shaft tip is retained in the opening **208** in a fixed manner, and the clamp **194** positively engages the butt of the shaft, whereby the shaft axis **186** is substantially parallel to the ground plane **118**. To measure the torsional displacement angle of a golf club shaft, the torque wheel **210** is actuated by moving (manually or in an automated manner, e.g., pneumatically) one of the support members away from its respective mass element until slack **234** or **236** at the corresponding end of the tether **212** is taken up completely. A torque of one ft-lb is then applied to the shaft **180** as the torque wheel **210** rotates in either the clockwise or counterclockwise direction, depending on which support member is moved away from its corresponding mass element. The tether **212** includes sufficient slack **234** and **236** at the opposing ends thereof to permit unrestricted angular twisting of the shaft tip relative to the butt portion of the shaft when the shaft **180** is subject to a torque of one ft-lb, produced by one of the mass elements acting on the torque wheel **210**. The torsional displacement angle measured by the inclinometer **238** is displayed on the readout **232**. Preferably, the

torsional displacement angle of the shaft is tested in both the clockwise and counterclockwise directions and an average reading is obtained.

FIG. **16** schematically illustrates a device for locating a balance point **238** of the shaft **180** relative to a butt end **240** of the shaft. The device includes two weight scales **242** and **244** having weight-bearing elements **246** and **248**, respectively, oriented such that the shaft axis **186** is substantially horizontal. The shaft **180** is supported by the weight-bearing element **246** an empirically measured horizontal distance Z from the butt end **240** of the shaft, a known horizontal distance D of 30 inches from the weight-bearing element **248**, and a horizontal distance X from the shaft balance point **238**. Distance X is determined using the equation:

$$X = (M_2 / M_{total})D - Z,$$

where M_2 corresponds to the mass reading of the weight scale **244** and M_{total} corresponds to the sum of mass readings of both scales **242** and **244**. A horizontal distance BP_s between the shaft balance point **238** and the butt end **240** of the shaft **180** is calculated using the following equation:

$$BP_s = Z + X.$$

The horizontal distance between the balance point **238** and a tip end **250** of the shaft **180** is found by subtracting the horizontal distance BP_s from the overall shaft length L_s .

FIG. **17** schematically illustrates a device for locating a balance point **252** of the club **178** relative to the butt end **254** of the grip **188** of the golf club. The device includes the two weight scales **242** and **244** having the weight-bearing elements **246** and **248**, respectively, oriented such that the shaft axis **186** is substantially horizontal. The shaft **180** of the golf club **178** is supported by the weight-bearing element **246** an empirically measured horizontal distance W from the butt portion **254** of the grip **188**, a known horizontal distance D of 30 inches from the weight-bearing element **248**, and a horizontal distance Y from the club balance point **252**. Those skilled in the art will appreciate that the length of the grip dome **190** is not included when measuring the horizontal distance W . Distance Y is obtained using the equation:

$$Y = (M_2 / M_{total})D - W,$$

where M_2 corresponds to the mass reading of the weight scale **244** and M_{total} corresponds to the sum mass readings of both scales **242** and **244**. A horizontal distance BP_c between the club balance point **252** and the butt end **254** of the grip **188** of the golf club **178** is obtained using the following equation:

$$BP_c = W + Y.$$

The horizontal distance between the club balance point **252** and the bottom portion **108** of the golf club head **100** is determined by subtracting the horizontal distance BP_c from the overall club length L_c .

Referring to FIG. **18**, "sweet spot", e.g., the sweet spot **256**, as used herein, refers to the point of intersection between the front surface **114** and an imaginary line **258** that is substantially perpendicular to the front surface **114** and passes through the center of gravity CG of the club head **100**.

FIG. **19** schematically illustrates an apparatus **259** for measuring the bending stiffness of the shaft **180**, with the shaft constrained at the butt region. The apparatus includes a shaft-butt clamp **260**, having an anterior surface **262** and a posterior surface **264**, laterally spaced a horizontal distance of 3 inches from the anterior surface **262**, and a shaft-butt stop **266**, laterally spaced a horizontal distance of 8 inches from the anterior surface **262** of the clamp **260**. The shaft

180 is fixed in the clamp **260**, whereby the butt end **240** of the shaft **180** abuts the stop **266** and the shaft axis **186** is substantially parallel to the ground plane **118**. To measure the bending stiffness in the butt region of the shaft **180**, the shaft is loaded with a mass of 2700 g, whereby a force F is applied to the shaft vertically downward at a horizontal distance of 30 inches from the anterior surface **262**. The force F will displace the central axis of the shaft **180** downward from its neutral position. A deflection D_1 , corresponding to the downward displacement of the shaft axis, is measured at a horizontal distance of 33.5 inches from the anterior surface **262** of the clamp **260** and is inversely proportional to the bending stiffness of the cantilever portion of the shaft **180**.

FIG. **20** schematically illustrates an apparatus **267** for measuring the bending stiffness of the shaft **180**, with the shaft constrained at the tip region. The apparatus includes a shaft-tip clamp **268**, having a front surface **270** and a rear surface **272**, laterally spaced a horizontal distance of 2 inches from the front surface **270**, and a shaft-tip stop **274**, laterally spaced a horizontal distance of 2.5 inches from the front surface **270** of the clamp **268**. The shaft **180** is fixed in the clamp **268**, whereby the tip end **250** of the shaft **180** abuts the stop **274** and the shaft axis **186** is substantially parallel to the ground plane **118**. To measure the bending stiffness in the tip region of the shaft **180**, the shaft is loaded with a mass of 2700 g, whereby a force F is applied to the shaft vertically downward at a horizontal distance of 24 inches from the front surface **270**. The force F will displace the central axis of the shaft **180** downward from its neutral position. A deflection D_2 , corresponding to the downward displacement of the shaft axis, is measured at a horizontal distance of 27.5 inches from the front surface **270** of the clamp **268** and is inversely proportional to the bending stiffness of the cantilever portion of the shaft **180**.

The bulge and roll of a driver club head may be measured using, e.g., the Radius Dial Gauge Type A, available from Chengdu Sharpline Co., Ltd. of Chengdu, China. The bulge and roll of a fairway wood or hybrid club head may be measured using, e.g., the Golf Wood Club Face Radius Gauge, available from The Golfworks, Inc. of Newark, Ohio.

The swing weight of a golf club may be measured using, e.g., The Maltby Design® Golf Club Scale, available from The Golfworks, Inc. of Newark, Ohio.

The term “volume”, as used herein, denotes the volume measured using the method described in the Procedure for Measuring the Club Head Size of Wood Clubs, Revision 1.0, Section 5 (Nov. 21, 2003), as specified by the United States Golf Association (USGA) and the R&A Rules Limited (R&A).

“Discretionary mass”, as used herein, refers to the difference between the target mass of the club head and the minimum structural mass required to form the head.

Referring to FIG. **21**, a golf club **300**, according to one or more aspects of the present invention, includes a head **302**, a shaft **304**, having a tip end **340** and a butt end **336**, and a grip **306**, having a butt portion **309**. The club **300** also includes a club balance point **307** and a shaft balance point **338**. The golf club **300** has a light-weight construction wherein the total mass of the club is less than about 300 g, preferably less than 295 g, more preferably between about 285 g and about 295 g, and most preferably between about 250 g and about 285 g. The light-weight golf club **300** delivers a greater swing speed (i.e., club-head speed) and increased initial ball velocity, promoting extended travel distance of the golf ball. Since players are generally accus-

tomed to a particular club swing weight, or weight distribution, about the club balance point **307**, the swing weight of the light-weight golf club **300** is maintained within a range preferred by the player. Accordingly, the light-weight golf club **300** has a swing weight preferably between D0 and D8, more preferably between D0 and D6, and most preferably between D2 and D5. To maintain the swing weight of the club head **300** within the desired range, the club balance point **307** is preferably located a distance BP_c of no more than 34 inches from the butt portion **309** of the grip **306** and more preferably no more than 35 inches from the butt portion **309**. The golf club **300** may further comprise an overall club length L_c of at least about 45 inches, preferably at least about 46 inches, and more preferably at least about 47 inches, to further increase the club head speed. The ratio of the club balance point distance BP_c from the butt portion **309** to the overall club length L_c may be greater than 0.76, preferably greater than 0.77, and more preferably greater than 0.78. The ratio of the club weight to the club balance point distance BP_c from the butt portion **309** may be no more than 8.5, preferably no more than 8.4, and more preferably no more than 8.3.

As shown in FIGS. **21** and **22**, the golf club head **302**, according to one or more aspects of the present invention, may comprise a front portion **308** and a club head body **310** having a toe **312**, a heel **314**, a bottom portion **316**, a top portion **318**, and a hosel **320**. The front portion **308** may comprise a face plate **321** that is coupled to the club head body **310**, e.g., by mechanical interlocking, welding, brazing, or adhesive bonding. The head body **310** and/or the front portion **308** may comprise a metallic and/or non-metallic material, e.g., stainless steel, titanium, or fiber-reinforced plastic. Preferably, the front portion **308** is formed from a different material than the head body **310**. In other examples, the front portion **308** and the head body **310** may comprise the same material.

As illustrated in FIG. **23**, the club head body **310** may have a multi-piece construction comprising a top plate **323**, a bottom plate **325**, and a hosel member **327**. The top plate **323** may be coupled to the bottom plate **325**, e.g., by mechanical interlocking, welding, or brazing. The top plate **323** may include a curved section **319**, which constitutes a portion of a hosel opening (not shown), when the top plate **323** is coupled to the face plate **321** and the bottom plate **325**. The hosel member **327** may comprise an upper portion **329**, having a shaft opening **331** and a bottom lip **333**, and a lower portion **335** to be entirely inserted into the hosel opening (not shown). The lower portion **335** may be coupled to the face plate **321**, e.g., by mechanical interlocking, welding, brazing, or adhesive bonding. The bottom lip **333** of the hosel may be joined, e.g., by welding, brazing, mechanical interlocking, or adhesive bonding, to at least the top and bottom plate **323** and **325**, and may also be optionally attached to the face plate **321**. The face plate **321**, the top plate **323**, and the bottom plate **325** are preferably formed from metal sheet via a stamping operation to promote greater manufacturing efficiency, lower production costs, and a lighter club weight. Alternatively, the face plate **321**, the top plate **323**, and/or the bottom plate **325** may be formed via a forging and/or casting process. In another example, the top plate **323** may comprise a non-metallic material, such as fiber-reinforced plastic.

Preferably, the face plate **321** has a variable or constant thickness between about 2.00 mm and about 5.00 mm, more preferably, between about 2.25 mm and about 4.00 mm, and, most preferably, between about 2.50 mm and about 3.80 mm. The top plate **323** may have a thickness between about

0.25 mm and about 3.00 mm, preferably, between about 0.25 mm and about 2.00 mm, and, more preferably, between about 0.50 mm and about 1.00 mm. The bottom plate **325** may have a thickness between about 0.50 mm and about 3.00 mm, preferably, between about 0.50 mm and about 2.00 mm, and, more preferably, between about 0.50 mm and about 1.25 mm.

As shown in FIG. **24A**, the golf club, according to one or more aspects of the invention, may include a club head **300a**, having a cup-face portion **320a**, which comprises a front portion **308a** with an annular aft portion **322a**, extending therefrom. The annular aft portion **322a** may be integral with the front portion **308a** and may be coupled to a club head body **310a** via one of the joining methods described above. In another aspect of the present invention, illustrated in FIG. **24B**, the golf club may include a club head **300b**, comprising a front portion **308b**, which has a face insert **324b** and a peripheral portion **326b**, integrally formed with a club head body **310b**. The face insert **324b** and the peripheral portion **326b** may comprise the same or different materials. The face insert **324b** may be coupled to the peripheral portion **326b** via one of the joining methods discussed above.

Referring back to FIG. **21**, the head of the golf club **300** preferably has a mass less than about 205 g, more preferably less than about 200 g, and most preferably between about 190 g and about 200 g. Decreasing the club head mass below 190 g unfavorably lowers the MOI and impact momentum of the club head, leading to a reduction in club-head forgiveness and ball travel distance. A high MOI improves club head performance on off-center hits by reducing slice/hook tendencies. Accordingly, the primary MOI of an exemplary club head may be at least about 4000 g·cm², more preferably at least about 4500 g·cm², and most preferably at least about 5000 g·cm². The secondary MOI of the club head, according to one or more aspects of the present invention, may preferably be at least about 2500 g·cm² and more preferably at least about 3000 g·cm².

As illustrated in FIG. **22**, to compensate for the undesirable spin characteristics (“gear effect”) associated with off-center ball strikes, the front portion **308** of the exemplary club head **302** may include a bulge dimension **328** and a roll dimension **330**. Since the club head **302** has a relatively large MOI, the front portion **308** may incorporate a bulge **328** and a roll **330** of a larger radius; to promote improved shot accuracy. For example, the bulge dimension **328** of the exemplary club head **302** may preferably have a radius of between about 11 inches and about 16 inches, and, more preferably, between about 13 inches and about 15 inches. Similarly, the roll dimension **330** of the exemplary club head **302** may preferably have a radii between about 9 inches and about 15 inches, and, more preferably, between about 11 inches and about 14 inches.

In one example, the club head according one or more aspects of the invention may have an overall width W_o (see FIG. **13**) and/or an overall length L_o (see FIG. **12**) of at least about 3 inches, preferably at least about 4 inches, more preferably at least about 5 inches, and most preferably at least about 5.5 inches. The volume of the club head **302** may be at least about 360 cm³, preferably at least about 400 cm³, more preferably at least about 430 cm³, and most preferably at least about 450 cm³.

Referring to FIG. **25**, the front portion **308** of the exemplary club head **302** includes a face center **332** and a sweet spot **334**. Typically, the face center is located at or near a point on the front portion **308** where maximum face rebound and energy transfer occur at ball impact. The face center is also known as the Coefficient of Restitution (COR) “hot

spot”. The “Coefficient of Restitution” of the face center may be found using the general methodology disclosed in the Procedure for Measuring the Flexibility of a Golf Clubhead, Revision 2.0 (Mar. 25, 2005), as specified by the United States Golf Association (USGA). Preferably, the COR at the face center **332** is at least 0.81 and, more preferably, at least 0.82. The “sweet spot” is the point on the front portion of the club head where no head rotation occurs at ball impact. Since golfers have a natural tendency to strike the golf ball about the face center of the club head, the center of gravity CG of the club head **302** may be beneficially oriented so that the sweet spot **334** of the club head is substantially coincident with the face center **332**. Accordingly, the benefits of increased shot distance, associated with striking the ball at the face center **332**, and improved accuracy, associated with impacting the ball at the “sweet spot” **334**, may be simultaneously realized.

In the light-weight golf club **300** (see FIG. **21**), according to one or more aspects of the present invention, the mass of the shaft **304** is less than about 55 g, preferably less than about 50 g, more preferably less than about 40 g, and most preferably less than about 30 g. Those skilled in the art of golf-club making generally recognize that for the majority of players, the front portion (face) of the club head remains “open” at ball impact, resulting in a tendency to slice the ball. As mass is removed from the shaft **304**, the torsional stiffness of the shaft is reduced, producing a club head that rapidly “closes” at ball impact. A face that is suddenly “closed” just prior to ball impact will increase ball speed, improve shot consistency, and create more draw bias (i.e., remove the fade or slice bias). To realize these benefits, the exemplary shaft **304** may have an torsional displacement angle of at least about 5°, preferably at least about 5.5°, more preferably at least about 6°, and most preferably between about 5° and about 7°.

A reduction in the torsional stiffness of a shaft may produce a golf club that communicates a vague feel to the player, causing inconsistent shots. Accordingly, the bending stiffness in the butt region of the shaft **304**, in one or more aspects of the present invention, may be increased, relative to the bending stiffness in the tip region, to generate a more solid feel in the shaft region proximate the golfer’s hands, thus promoting a tendency to create shaft loading that increases club-head speed and ball-launch angle at impact. One way to improve the bending stiffness in the butt region of the exemplary shaft **304** is to increase the outer diameter of the shaft in the butt region. In one example, a portion of the butt region may have a substantially constant outer diameter between about 0.63 inches and about 0.75 inches, preferably between about 0.65 inches and about 0.73 inches, and more preferably between about 0.65 inches and about 0.69 inches. Alternatively, the increased outer diameter of the butt region may gradually taper from the butt end **336** of the shaft **304** toward the tip. To improve feel even further, the deflection D_1 of the shaft (see FIG. **19**), according to one or more aspects of the present invention, may preferably be between about 50 mm and about 100 mm, more preferably between about 60 mm and about 95 mm, and most preferably between about 70 mm and about 90 mm. The deflection D_2 of the shaft (see FIG. **20**) is preferably between about 70 mm and about 150 mm, more preferably between about 80 mm and about 150 mm, and most preferably between about 90 mm and about 150 mm. The ratio of the deflection D_2 to the deflection D_1 is preferably at least about 1.46, more preferably at least about 1.48, and most preferably at least about 1.50.

13

The length L_s of the shaft, according to one or more aspects of the present invention, is preferably at least about 42 inches, more preferably at least about 43 inches, and most preferably at least about 44 inches. The exemplary shaft **304** preferably has a shaft balance point **338** located a distance BP_s (see FIG. **21**) from the butt portion **309** of the grip that is no more than 24 inches, more preferably no more than 22 inches, and most preferably no more than 19 inches from the butt end **336** of the shaft **304**. To maintain the club swing weight within the preferred range, the ratio of the shaft balance point distance BP_s to the shaft length L_s may be less than 0.47, more preferably less than 0.46, most preferably less than 0.45, and most preferably less than 0.44. The exemplary golf club may have a balance point value $((BP_c/L_c)/(BP_s/L_s))$ of at least about 1.68, preferably at least about 1.70, and more preferably at least about 1.72.

Referring once again to FIG. **21**, the exemplary grip **306**, according to one or more aspects of the present invention, comprises a mass less than 50 g, preferably less than 40 g, more preferably less than 30 g, and most preferably less than 25 g. A light-weight grip increases the swing weight of a golf club. Accordingly, to maintain the swing weight within a preferred range, about 3 g of mass may be removed from the grip for every 1 g of mass removed from the club head. The exemplary light-weight grip **306** further reduces the overall mass of the club head **300** to provide increased swing speed, while maintaining a preferred swing weight and solid feel of the golf club.

In the foregoing specification, the invention has been described with reference to specific exemplary aspects thereof. It will, however, be evident that various modifications and changes may be made thereto without departing from the broader spirit and scope of the invention as set forth in the appended claims. The specification and drawings are, accordingly, to be regarded in an illustrative rather than a restrictive sense.

14

What is claimed is:

1. A golf club comprising:
 - a club head having a volume of greater than about 360 cm³ and a mass less than 200 g;
 - a shaft attachable to the club head having a tip end, a butt end, and a shaft balance point distance, BP_s , as measured from the butt end, of no more than 19 inches; and a golf club mass less than 300 g;
 - an overall club length, L_c ; and
 - a club balance point distance, BPC_c , measured from the butt end of the shaft;
 - wherein a ratio (BPC_c/L_c) is no less than 0.76.
2. The golf club of claim 1, wherein the shaft further comprises a shaft length, L_s , no less than 44 inches.
3. The golf club of claim 1, wherein, respective to an imaginary coordinate system having an x-axis, a y-axis, a z-axis and an origin located at a center of gravity of the club head, the club head has a moment of inertia about the z-axis of at least about 4000 g-cm².
4. The golf club of claim 3, wherein the MOI about the z-axis is about 4500 g-cm².
5. The golf club of claim 1, wherein the mass of the golf club is less than 295 g.
6. The golf club of claim 1, wherein the mass of the golf club is between 285 g and 295 g.
7. The golf club of claim 1, wherein the overall club length, L_c , is no less than 45 inches.
8. The golf club of claim 1, wherein a ratio of the mass of the club head to the club balance point distance, BPC_c , is no greater than 8.5 grams/inch.
9. The golf club of claim 1, wherein the mass of the club head is between 190 g and 200 g.
10. The golf club of claim 1, further comprising a torsional displacement angle of greater than about 5.5°.
11. *The golf club of claim 1, wherein the club head further comprises a fiber-reinforced plastic material.*

* * * * *