



US 20120240754A1

(19) **United States**
(12) **Patent Application Publication**
JAMES

(10) **Pub. No.: US 2012/0240754 A1**
(43) **Pub. Date: Sep. 27, 2012**

(54) **EXPENDED CARTRIDGE CASE RECEIVER**

Publication Classification

(76) Inventor: **William JAMES**, League City, TX (US)

(51) **Int. Cl.**
F41A 35/00 (2006.01)
(52) **U.S. Cl.** **89/33.4**

(21) Appl. No.: **13/411,854**

(57) **ABSTRACT**

(22) Filed: **Mar. 5, 2012**

Disclosed is an expended cartridge case receiver unit which catches and contains cartridge cases ejected clear of a firearm and keeps them from underfoot of the shooter. The receiver unit has a weight bearing surface that allows an ejected cartridge case to pass through it into a case trap portion disposed below it. A plurality of the case receiver units can be arranged in a series with the case trap portion of each receiver unit in communication with the case trap of an adjacent receiver unit in the series.

Related U.S. Application Data

(60) Provisional application No. 61/466,324, filed on Mar. 22, 2011.

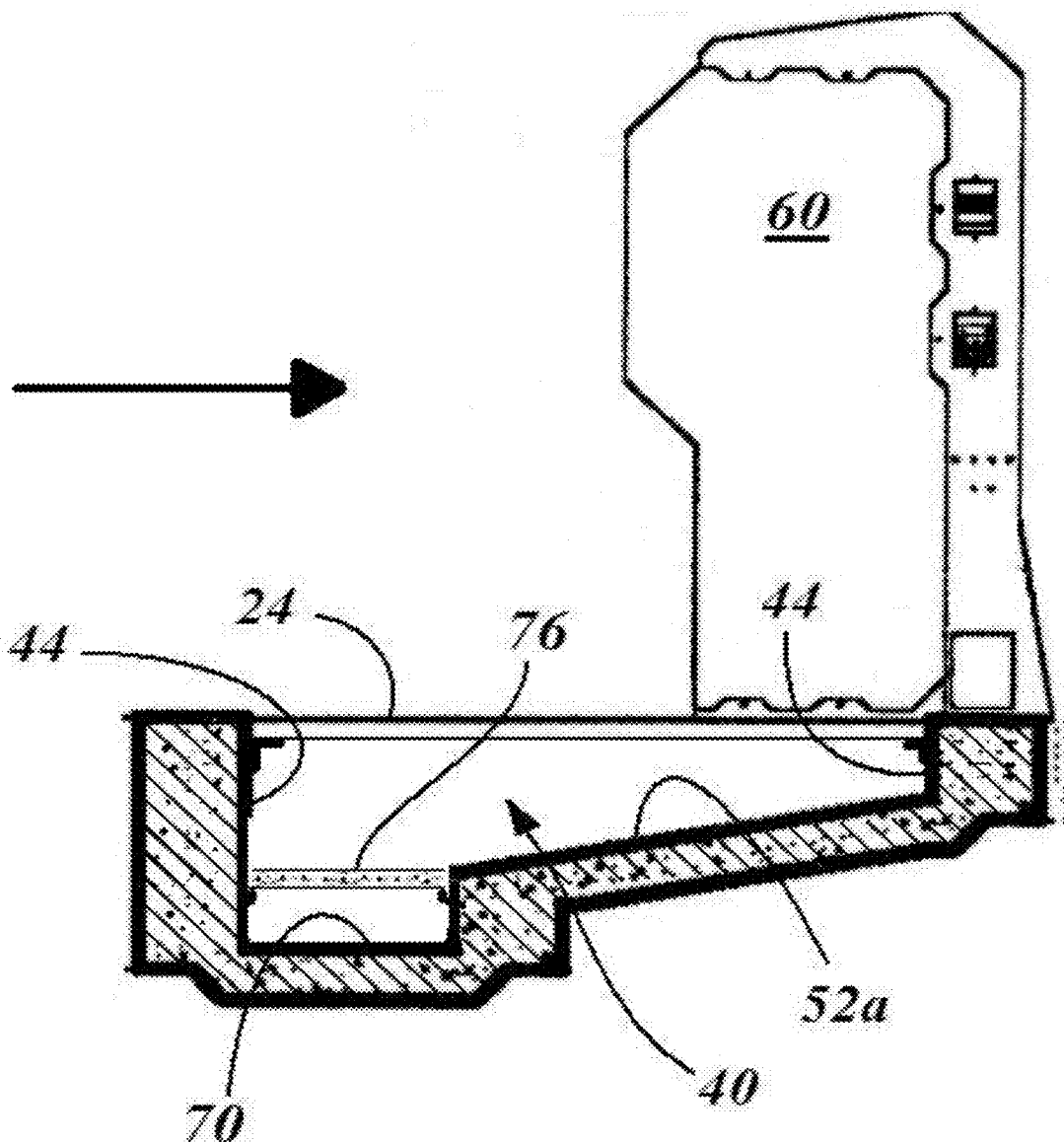

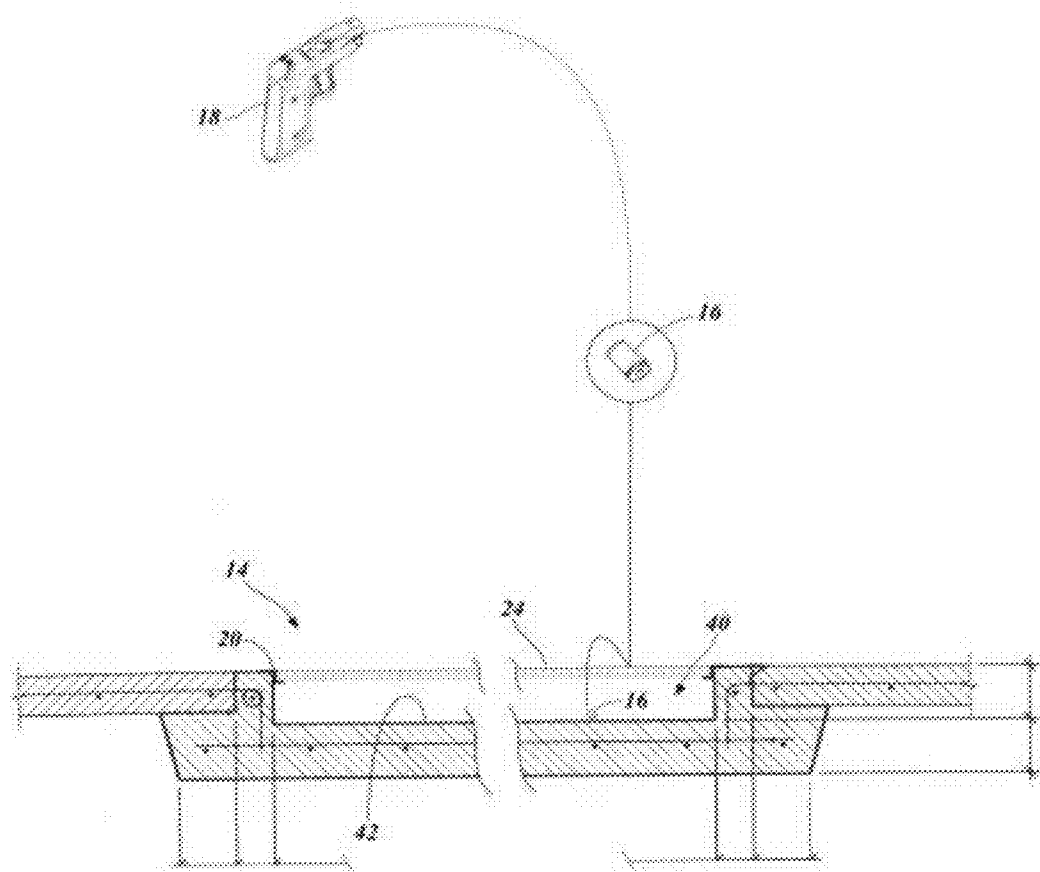

Fig. 1

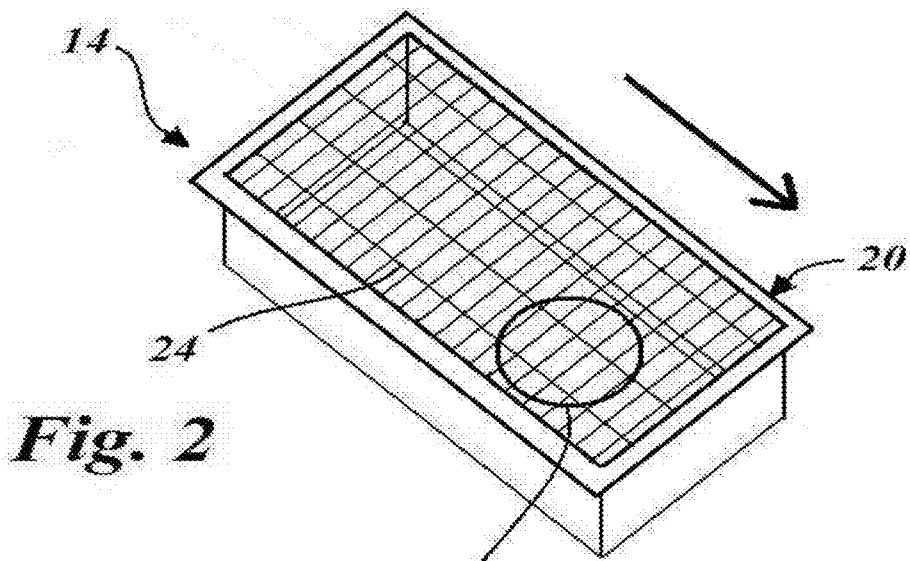

Fig. 2

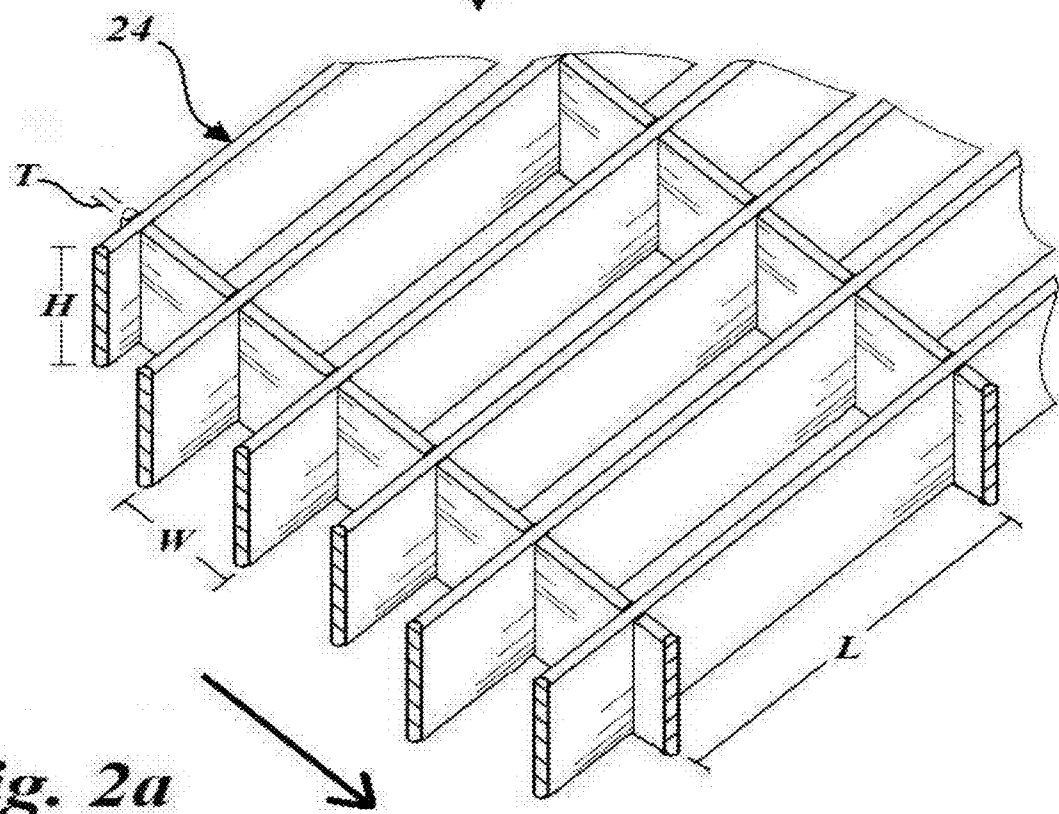
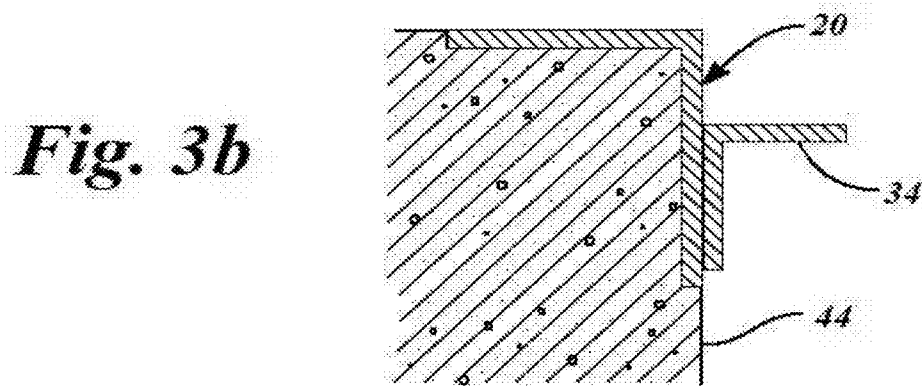
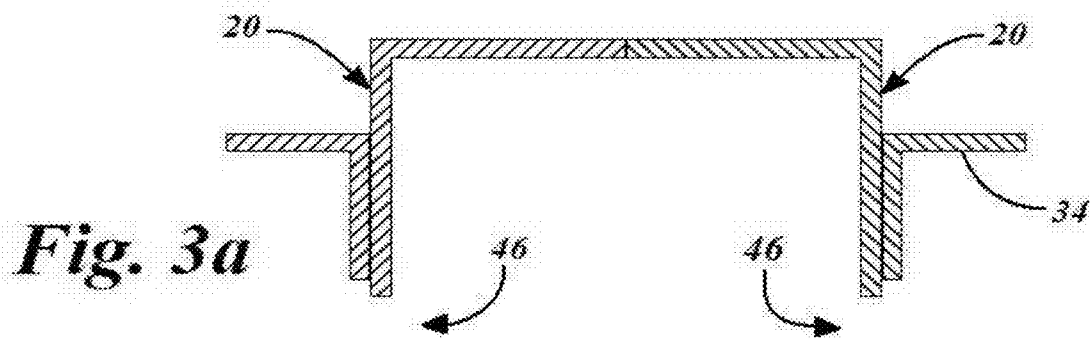
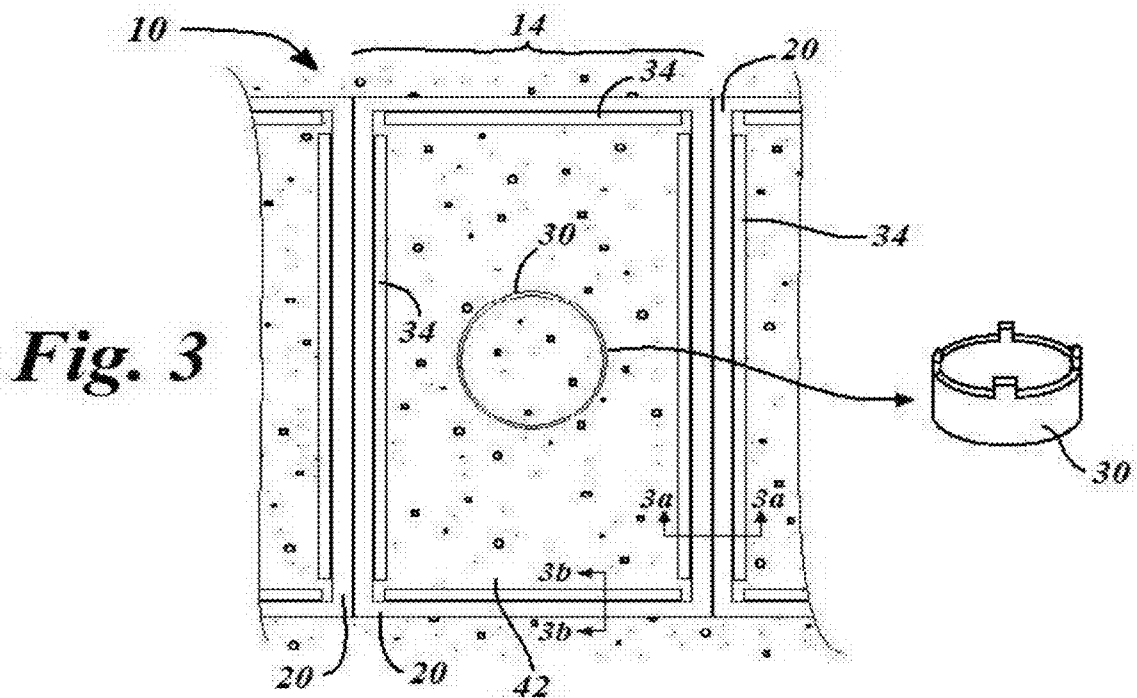

Fig. 2a



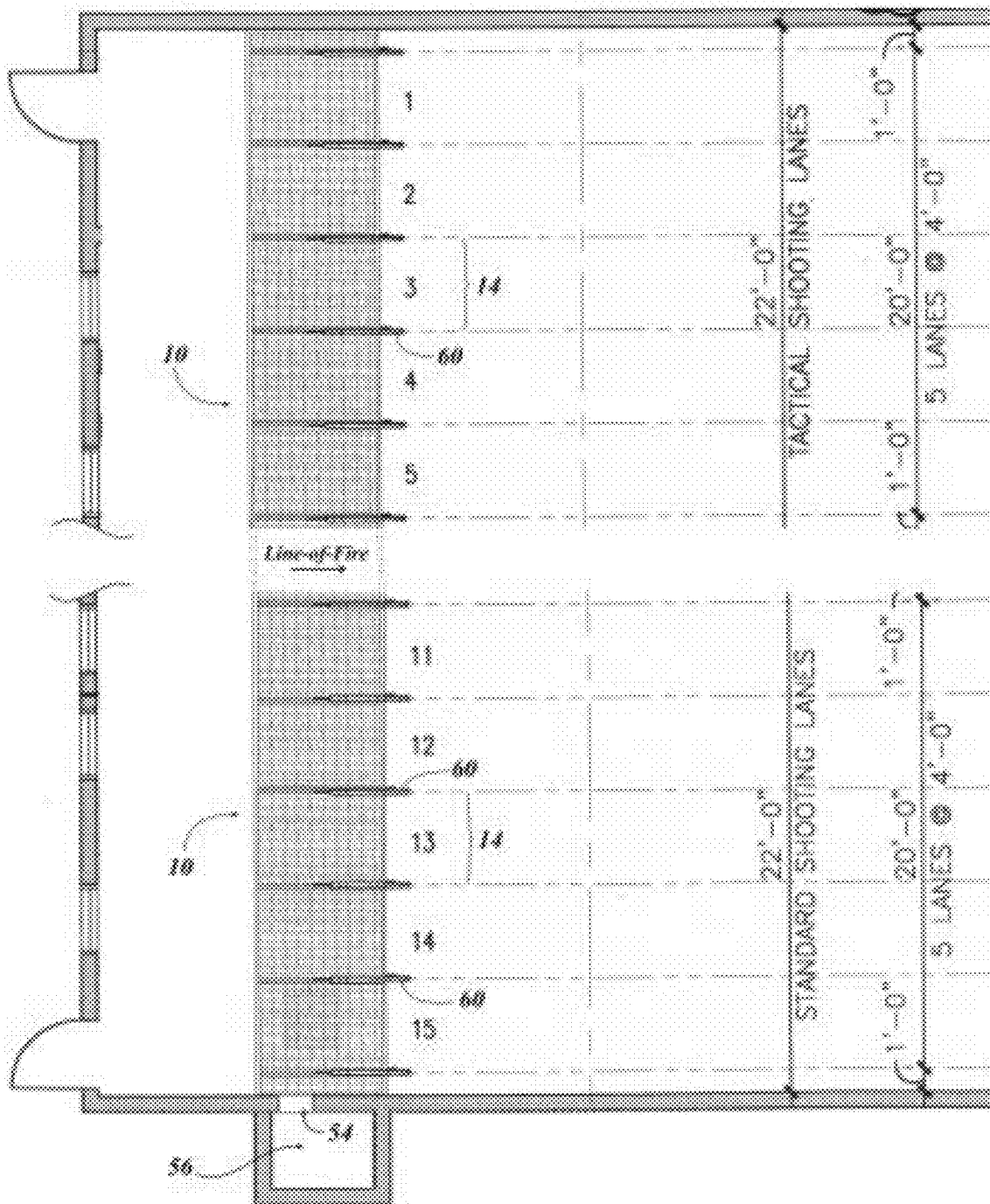

Fig. 4

Fig. 5a

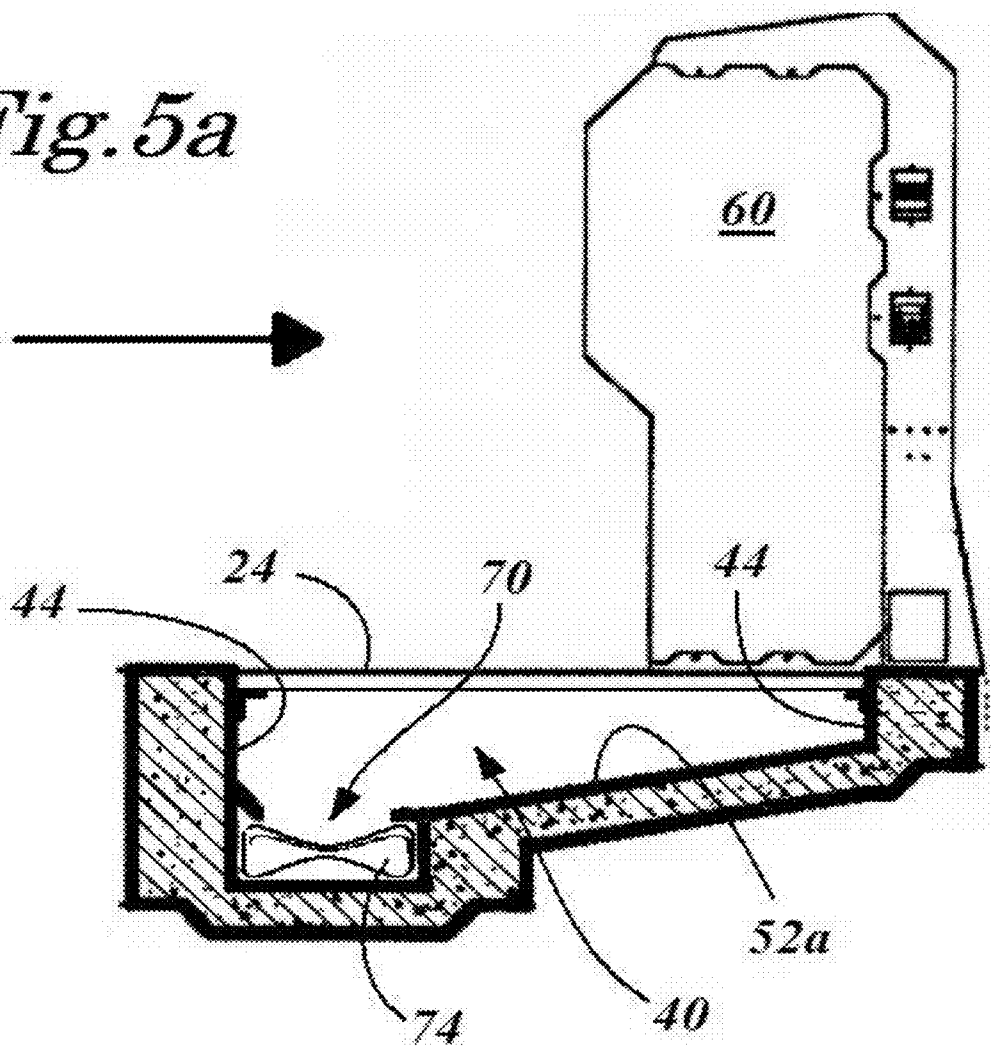
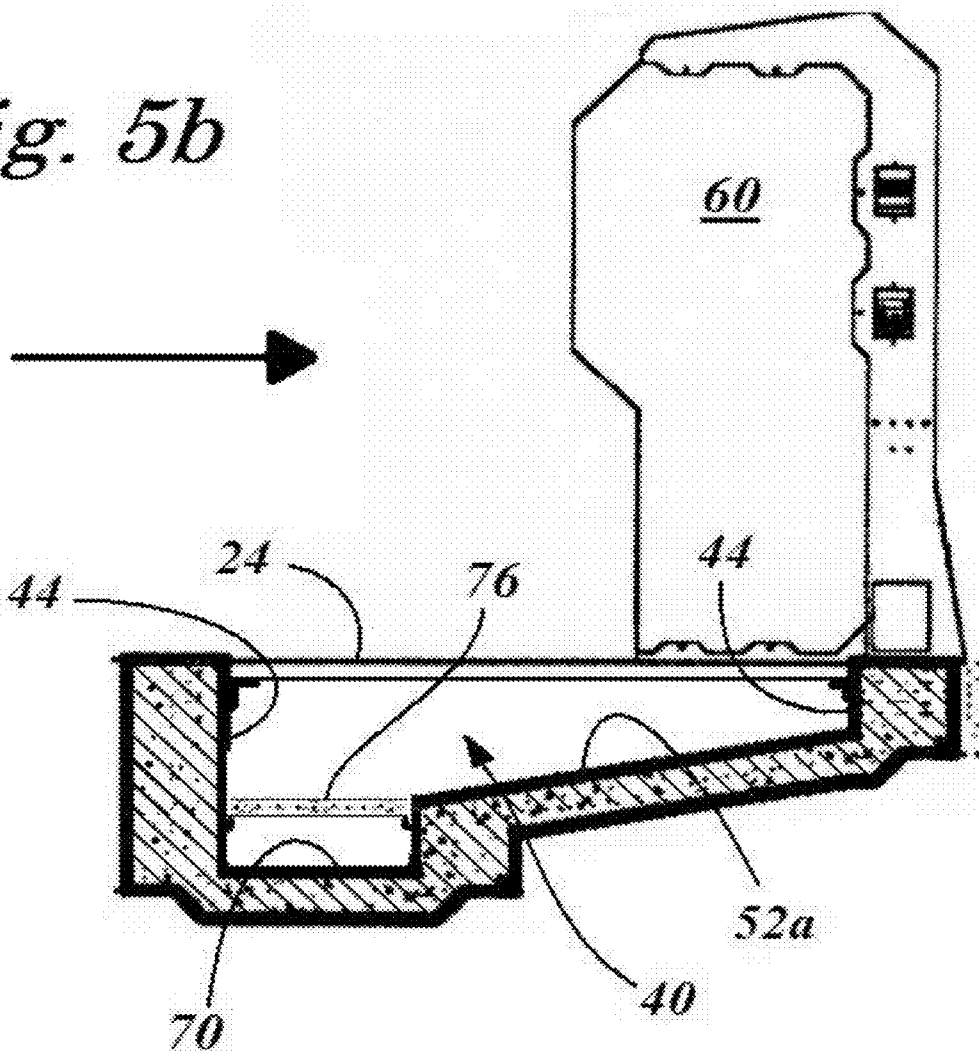

Fig. 5b



EXPENDED CARTRIDGE CASE RECEIVER

[0001] The instant application claims the benefit of prior filed U.S. Provisional Application Ser. No. 61/466,324 of the same title, filed 22 Mar. 2011, to which this application is a US national utility application.

FIELD OF THE INVENTION

[0002] The present invention is in the field of ordinance (Class 89) as related to explosion-operated guns including hand and shoulder firearms. Specifically, the present invention relates to empty shell receivers (Subclass 33.4) to catch spent cartridge cases ejected from a hand or shoulder operated firearm. More specifically, the present invention relates to such empty shell receivers adapted for use in a shooting range.

BRIEF DESCRIPTION OF THE DRAWINGS

[0003] FIG. 1 is cross-sectional view of the present invention illustrating an example of a cartridge case receiver unit and the shell case pass-thru feature of the receiver cover.

[0004] FIGS. 2 and 2a are perspective drawings illustrating a simplified cartridge case receiver unit, showing a receiver trap and a detailed portion of a receiver cover.

[0005] FIG. 3 is a top plan of a series of cartridge case receiver units with their receiver covers removed.

[0006] FIGS. 3a-3b are cross-sectional drawings of features exemplifying construction of the cartridge case receiver units of FIG. 3.

[0007] FIG. 4 is a top plan view of the present invention with the cartridge case receiver illustrated as a series of communicating receiver units (1 to 15) along a shooting range firing line as the invention was practiced in an indoor shooting range.

[0008] FIG. 5a is a cross-sectional view through a trap of a cartridge case receiver unit of FIG. 4 incorporating a sump portion with a conveyer belt.

[0009] FIG. 5b is a cross-sectional view through a trap of a cartridge case receiver unit of FIG. 4 incorporating a drain sump portion.

DESCRIPTION OF THE INVENTION

[0010] The present invention is an expended cartridge case receiver for catching and containing spent cartridge cases after they are ejected clear from a firearm. The present case receiver is specifically intended to trap shell cases ejected from a hand or shoulder operated firearm. Also, the present case receiver is intended to be constructed into the floor structure of an indoor or outdoor pistol/rifle shooting range. Referring now to the drawings, the details of preferred embodiments of the present invention are graphically and schematically illustrated. Like elements in the drawings are represented by like numbers, and any similar elements are represented by like numbers with a different lower case letter suffix.

[0011] The expended cartridge case receiver 10 of the present invention in its preferred embodiment comprises a plurality of individual expended cartridge case receiver units 14, arranged in a series. Each individual cartridge case receiver unit 14 is adapted to catch and contain cartridge cases 16 ejected clear of a firearm 18, while supporting a shooter and the shooter's gear. As exemplified in FIGS. 1 and 2-2a, an

individual cartridge case receiver unit 14 includes: a horizontal platform 20, a receiver cover 24 with a grated cross-section 26, and a cartridge/shell case trap 40. Generally, the shell case trap 40 of a case receiver unit 14 has a box-shaped configuration with a floor 42 that is flat or is inclined—the latter to use gravity to help focus collection of the trapped shell cases 16. In a preferred embodiment, an individual receiver unit 14 defines an individual shooting lane (see FIG. 4).

[0012] The horizontal platform 20 is a weight-bearing surface capable of supporting a shooter and the shooter's gear. A receiver or trap cover 24 is integrated into the platform 20. The receiver/trap cover 24 is a grate or has a grated cross-section 26. The length L and width W dimensions of the openings 28 in the grated cross-section 26 are sufficient to allow an ejected cartridge cases 16 to pass through the platform 20 while supporting the shooter and the shooter's gear. In a preferred embodiment, the openings 28 had a length L of about 4 inches and width W of about 1 inch. The height H and thickness T of the grate 26 is selectable by one of skill in the art to provide the structural integrity necessary to support the weight intended by a user that the platform 20 and receiver cover 24 is to carry. It is preferred that the thickness T be selected to be as small as possible while providing the desired structural integrity for the safety reason set forth below.

[0013] It is to be noted that the asymmetric shape of the trap cover openings 28 and orientation of the openings 28 relative to the line-of-fire (arrow) of the shooting lane are both important. The openings 28 are preferred to have a length L sufficient to allow the length of substantially all shoulder operated firearms to easily fall through the receiver cover 24 of the platform 20, as these types of shell cases have a diameter typically much smaller than their length. A rectangular or oblong opening having a length L of about 3-4 inches is satisfactory for this feature. Additionally, the openings 28 are preferred to have a width W sufficient to allow the length of a .45 ACP caliber cartridge case (~7/8ths of an inch) to fall through the receiver cover 24. Dimensions substantially larger than these may be useful for some special purposes, but generally increasing the dimensions tends to make the quality of the cover's surface less suitable for a shooter to stand on. This is particularly true if the shooter is wearing footwear with a small heel surface. Dimensions substantially smaller than these may improve the quality of the cover surface more suitable for standing, but will increase the occurrence of cases that land on the cover surface and fail to pass through the trap cover 24.

[0014] Another important feature of the trap cover 24 is the orientation of the cover openings 28 relative to the line-of-fire (arrow) of the shooting lane. It was unexpected to find that even heavy duty steel grating of the type generally used for catwalks and other walkways supporting human foot traffic was not suitable unless the opening 28 were specifically oriented in the cartridge case receiver unit 14 relative to the line-of-fire. Specifically, the length L dimension is to be oriented perpendicular to the line-of-fire (arrow) of the shooting lane. This orientation reduces the tendency of the trap cover 24 to give or sag under the weight of one or more shooters moving about on it. This improved cover surface stability is important for the handling of a loaded firearm. Additionally, this orientation allows a wheel chair (or other wheeled device) to be rolled onto the platform 20 without risk of narrow wheels becoming bound along length of the cover openings 28.

[0015] The receiver/trap cover 24 in the preferred embodiment is removable to allow access to the interior of the cartridge/shell case trap 40 below. If it is desired to use a light-weight receiver cover 24 on the platform 20, a cover support 30 (such as the pedestal 30 set on the floor 42 of the cartridge case trap 40 in FIG. 3) may be used to bolster the receiver cover 24 from below. Using a light-weight receiver cover 24 on the platform 20 has the benefit of making the cover itself easier to remove to access the interior of the cartridge trap 40. Also, a cover support 30 is useful when it is intended to place extra-heavy loads on the platform that are beyond the design limit of the receiver cover 24 alone.

[0016] FIG. 3 show a top plan of a cartridge case receiver unit 14 in a series of adjacent case receiver units 14. The receiver covers 24 are removed to illustrate a preferred embodiment of the present invention 10. The figure shows a horizontal platform 20 as a metal framework including cover ledges 34 for supporting the perimeter of the receiver cover 24. In this embodiment, the case trap 40 for catching and containing the ejected cartridge cases 16 was constructed as a concrete catchment disposed below and covered by the grated cross-section 26 of the receiver cover 24. The catchment had solid front and back side walls 44 and in this embodiment a trap floor 42 that was flat. The front and back side walls 44 were perpendicular to the line-of-fire (see arrow, FIG. 3b). In this embodiment, only the cartridge case receiver units 14 at each end of the series of adjacent case receiver units 14 had a solid left or right side wall (not shown). All other case receiver units 14 in the series had left and right side walls 46 open to the adjacent unit 14 (i.e., adjacent units 14 were without a solid side wall at their left and right sides—see FIG. 3a).

[0017] FIG. 4 illustrates a preferred embodiment of the present expended cartridge case receiver 10 for catching and containing spent cartridge cases 16 after they are ejected clear from a firearm 18. In practicing this embodiment, the cartridge case receiver 10 was installed in an existing building as a series of fifteen adjacent cartridge case receiver units 14 to create the firing line of an indoor shooting range. As can be seen in the figure, each cartridge case receiver unit 14 defined the shooting position for an individual shooting lane. The illustrated expended cartridge case receiver 10 supports a plurality of individual shooters and catches and contains cartridge cases 16 ejected from a plurality of firearms 18, allowing the range floor in the vicinity of the firing line to be automatically clear of the hazard of ejected shell cases getting underfoot. Keeping the shooter's work area automatically clear of loose shell cases underfoot is a very important safety feature of the present invention.

[0018] The plurality of expended cartridge case receiver units 14 were arranged in a series with the case trap 40 of each receiver unit 14 in communication with an adjacent case trap 40 along the series. That is to say that adjacent case receiver units 14 were without a solid side wall between them (see FIG. 3a). The case receiver units 14 in this embodiment had a case trap 40 that was about 5.5 inches deep with a flat trap floor 42. The overall dimensions of the platform 20 was about 4 ft. wide and 5.5 ft. long. The receiver cover 24, was about 44 inches wide and 62 inches long and centered within the platform 20. The receiver cover 24 was accomplished using 1 in.x4 in.x1 in. walkway grating. These dimensions, though used quite successfully in the development of the instant embodiment, are merely exemplary. In view of the teaching and illustrations disclosed herein, one of skill in the art can chose other dimensions and materials to successfully practice the expended cartridge case receiver 10 of the present invention.

[0019] Also illustrated in the figure is a holding bin 58 into which the spent cartridge cases 16 collected from the case traps 40 of the individual receiver units 14 can be deposited. In this example, the holding bin 58 is outside the wall of the range and a pass-thru 54 in the range wall connects the interior of the bin 58 with the series of case traps 40 inside the shooting range. As shown in FIG. 5a, the movement of shell cases 16 from the series of adjacent case traps 40 can be accomplished using a conveyer system 74. As shown in the figure, this can be accomplished by adapting the case trap 40 to have an inclined floor 52a. Shell cases 16 passing through the receiver cover 24 are biased by gravity to move toward a sump trough 70 at the low portion of the inclined floor 52a. There the shell cases 16 are directed to fall on to a conveyer belt system 74 in the sump trough 70. The conveyer belt system 74 transports the shell cases 16 to the holding bin 58 and deposits them there for further disposition. Also illustrated in the figure is a baffle panel 60. Baffle panels are used in the art to limit/baffle the sound and concussion wave generated by a gun firing. In the present invention a baffle panel 60 is adapted to provide the added advantage of restricting the path of an ejected shell case to the vicinity of the case receiver unit 14 of the shooter.

[0020] FIG. 5b illustrates a trap of a cartridge case receiver unit 14 incorporating a wet sump trough 70 that serves as a rain water drain with a drain screen 76 to prevent shell cases 16 from entering the sump trough 70. This embodiment of the case receiver unit 14 is useful for practice in outdoor shooting ranges where the shooting lanes are exposed to the weather.

[0021] While the above description contains many specifics, these should not be construed as limitations on the scope of the invention, but rather as exemplifications of one or another preferred embodiment thereof. Many other variations are possible, which would be obvious to one skilled in the art. Accordingly, the scope of the invention should be determined by the scope of the appended claims and their equivalents, and not just by the embodiments.

What is claimed is:

1. An expended cartridge case receiver unit (14) for supporting a shooter and catching and containing cartridge cases (16) ejected clear of a firearm (18), the receiver unit (14) comprising:

- a horizontal platform (20), the platform being a weight-bearing surface capable of supporting a shooter and a shooter's gear;
- a receiver cover (24) integral with the platform (20) and having a grated cross-section (26) to allow an ejected cartridge case (16) to pass through the platform (20) while supporting the shooter and the shooter's gear; and
- a case trap (40) for catching and containing the cartridge case (16) ejected clear of the firearm (18), the case trap (40) disposed below and covered by the grated cross-section (26) of the receiver cover (24).

2. An expended cartridge case receiver (10) for supporting a plurality of shooters and catching and containing cartridge cases (16) ejected clear of a plurality of firearms (18), the case receiver (10) comprising: a plurality of expended cartridge case receiver units (14) of claim 1, arranged in a series and each receiver unit (14) having a case trap (40) in communication with an adjacent case trap (40) along the series.

* * * * *