



INTERNATIONAL APPLICATION PUBLISHED UNDER THE PATENT COOPERATION TREATY (PCT)

(51) International Patent Classification ⁶ : A61B 17/32	A1	(11) International Publication Number: WO 96/11638 (43) International Publication Date: 25 April 1996 (25.04.96)
--	-----------	--

(21) International Application Number: PCT/US95/13130
 (22) International Filing Date: 12 October 1995 (12.10.95)
 (30) Priority Data:
 08/322,680 13 October 1994 (13.10.94) US
 (71) Applicant: FEMRX [US/US]; 1221 Innsbruck Drive, Sunnyvale, CA 94089 (US).
 (72) Inventors: ALDEN, Donald, L.; 1312 Nelson Way, Sunnyvale, CA 94087 (US). KRESCH, Arnold, J.; 4 Horseshoe Bend, Portola Valley, CA 94028 (US). CHRISTIAN, Jeffrey, J.; 608 Curie Drive, San Jose, CA 95123 (US).
 (74) Agents: BARRISH, Mark, D. et al.; Townsend and Townsend and Crew, Stuart Street Tower, 20th floor, One Market Plaza, San Francisco, CA 94105 (US).

(81) Designated States: AL, AM, AT, AU, BB, BG, BR, BY, CA, CH, CN, CZ, DE, DK, EE, ES, FI, GB, GE, HU, IS, JP, KE, KG, KP, KR, KZ, LK, LR, LT, LU, LV, MD, MG, MK, MN, MW, MX, NO, NZ, PL, PT, RO, RU, SD, SE, SG, SI, SK, TJ, TM, TT, UA, UG, UZ, VN, European patent (AT, BE, CH, DE, DK, ES, FR, GB, GR, IE, IT, LU, MC, NL, PT, SE), OAPI patent (BF, BJ, CF, CG, CI, CM, GA, GN, ML, MR, NE, SN, TD, TG), ARIPO patent (KE, MW, SD, SZ, UG).

Published

With international search report.

Before the expiration of the time limit for amending the claims and to be republished in the event of the receipt of amendments.

(54) Title: METHOD AND DEVICE FOR TISSUE RESECTION

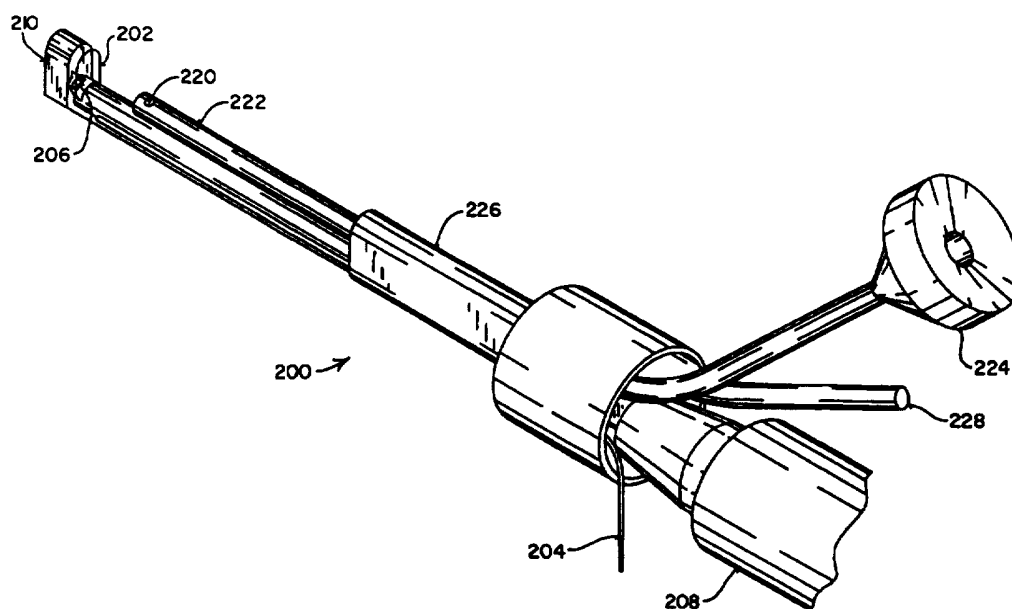

(57) Abstract

The present invention provides a tissue resection device comprising a handle housing (208) having a fluid infusion lumen (228). A shaft is reciprocally mounted to the housing, the shaft having an aperture adjacent to a distal end and a fluid and tissue aspiration lumen extending from the aperture to a proximal end of the shaft. A cutting member (202) is disposed adjacent to the aperture to sever tissue as the shaft is reciprocated, and an imaging mechanism (220) on the housing is oriented toward the cutting member (202), thereby allowing the attending surgeon to optically direct the removal of body cavity tissue. A chopping mechanism (206) is disposed within the lumen of the shaft to reduce the size of tissues passing through the lumen.

FOR THE PURPOSES OF INFORMATION ONLY

Codes used to identify States party to the PCT on the front pages of pamphlets publishing international applications under the PCT.

AT	Austria	GB	United Kingdom	MR	Mauritania
AU	Australia	GE	Georgia	MW	Malawi
BB	Barbados	GN	Guinea	NE	Niger
BE	Belgium	GR	Greece	NL	Netherlands
BF	Burkina Faso	HU	Hungary	NO	Norway
BG	Bulgaria	IE	Ireland	NZ	New Zealand
BJ	Benin	IT	Italy	PL	Poland
BR	Brazil	JP	Japan	PT	Portugal
BY	Belarus	KE	Kenya	RO	Romania
CA	Canada	KG	Kyrgystan	RU	Russian Federation
CF	Central African Republic	KP	Democratic People's Republic of Korea	SD	Sudan
CG	Congo	KR	Republic of Korea	SE	Sweden
CH	Switzerland	KZ	Kazakhstan	SI	Slovenia
CI	Côte d'Ivoire	LI	Liechtenstein	SK	Slovakia
CM	Cameroon	LK	Sri Lanka	SN	Senegal
CN	China	LU	Luxembourg	TD	Chad
CS	Czechoslovakia	LV	Latvia	TG	Togo
CZ	Czech Republic	MC	Monaco	TJ	Tajikistan
DE	Germany	MD	Republic of Moldova	TT	Trinidad and Tobago
DK	Denmark	MG	Madagascar	UA	Ukraine
ES	Spain	ML	Mali	US	United States of America
FI	Finland	MN	Mongolia	UZ	Uzbekistan
FR	France			VN	Viet Nam
GA	Gabon				

METHOD AND DEVICE FOR TISSUE RESECTION

5

10

BACKGROUND OF THE INVENTION

15 This invention relates to a method and device for tissue resection, especially for surgical treatment of the uterus or prostate.

20 Electrocautery has been in use for many years as a general surgical tool, such as for trans-cervical fibroid removal. The uterus is first flooded with a nonconductive fluid, such as sorbitol-mannitol fluid or the like under sufficient pressure to separate the walls of the uterus and render the surgical site suitable for optical fiber observation. This procedure is generally described as uterine cavity distension. During this flooding, an electrocautery surgical tool is inserted into the uterus through the cervix.

25 Electrical current at high voltage settings (typically an alternating current about 750 KHz and 2000-9000 volts) is transmitted from a cutting surface of the surgical instrument to the surgical site. The cutting surface usually consists of a wire or solid shape. The transmission of current to the

30 uterus is monopolar, and the circuit is completed by a conductive path to the power unit through a conductive pad applied to the patient's skin.

35 The electrical current is concentrated at the cutting surface. Heat generated from the resistance of tissue to the flow of electrical current is high enough to vaporize cells near the cutting surface. Thus, a cut is made with very little physical resistance to the cutting motion. Heat from

the cut cauterizes small blood vessels so that visibility and control remain good.

During uterine cavity distension, the same electrical resistance heating may be used at lower power settings to cauterize bleeding tissue and to kill selected areas of the tissue through ablation. Such cautery electrodes can be larger in area so as to treat broader surfaces. Cautery is used in gynecology to ablate the endometrial lining of the uterus. This procedure is often performed using a conductive roller which heats a wide swath of tissue along the inner surface of the uterus.

Electrocautery tools are compact and require a minimum of area in which to work. Since the tool only cuts when the power is turned on, it can be safely maneuvered into small areas. Electrocautery has found broad general application in the treatment of enlarged prostate glands and in the removal of uterine fibroids.

A secondary effect of the removal of tissue, particularly in the area of fibroid removal, is that separated tissue fragments typically remain in the working area and must be periodically flushed or suctioned away to preserve the required visibility necessary for surgery. The clean, well-controlled action of electrocautery is now slowed by this need to remove fragments which obstruct visibility. Therefore, the requirement for intermittent clearing of the surgical site prolongs fibroid removal and other electrosurgical procedures.

It is known that ultrasound can add significant value to tissue resection and ablation procedures. Using high-frequency ultrasound, anatomical landmarks and tissue features can be imaged in depth, which cannot be done by optical instruments. Depth information provides improved guidance and monitoring capabilities. It enables the surgeon to monitor the progress of tissue treatment, and thereby lessens the risk of complications. In addition, the improved visualization provided by ultrasound can help to shorten procedure times.

At the present time as for example during uterine cavity distention, it is not practical to introduce ultrasound probes without considerable complication.

To perform ultrasound measurements during electrocautery, the surgical probes for the electrocautery procedure must first be removed and thereafter, ultrasound introduced. Finally, and after such measurements, surgery can resume with reintroduction of the surgical probes. With such procedures, the surgeon has difficulty returning to the original surgical site. For this reason, ultrasound is not usually utilized for measurement of uterine wall thickness by an intrauterine transducer.

In grandparent U.S. Patent Application Serial No. 08/136,426, the full disclosure of which is incorporated herein by reference, an exemplary resection method and device included a rotating cutting head which chopped resected tissue into morsels, thereby facilitating the evacuation of resected tissue through the electrosurgical probe. Parent U.S. Patent Application Serial No. 08/322,680, which has also been incorporated herein by reference, provided resection methods and devices including both a rotating chopping mechanism and an electrosurgical cutting wire. The electrosurgical cutting wire of the parent application is particularly well-suited for removal of strips of tissue from the uterus, prostate, or other internal body cavities. The rotating chopping mechanism then severs the strips of removed tissue into morsels, allowing the electrosurgical cutting wire and rotating chopping mechanisms to be independently optimized for these two distinct cutting operations. Generally, the strips are directed toward the chopping mechanism by a combination of an endcap and aspiration fluid flow into the chopping mechanism. Preferably, the endcap comprises a wire frame which improves optical visualization beyond the distal end of the probe, but any endcap structure protruding radially from the probe adjacent to the aperture has been found to decrease the cutting depth and increase cutting drag, particularly at the beginning of each cut.

Although the resection methods and devices of the parent and grandparent applications have proven to be highly effective, electrosurgical resection methods could benefit from still further improvements. In a first aspect, although the frame endcap of the parent application provides a substantial improvement in distal optical visualization, some portion of the distal field of view remains blocked by this structure. In a second aspect, the electrosurgical cutting wire and chopping mechanism are most effective on tissues having a surface which is parallel to the probe axis, and it would be beneficial to incorporate some mechanism for treating tissues with surfaces disposed perpendicularly to that axis to facilitate treatment of the entire cavity without resorting to multiple specialized probes, articulation joints, or the like. In a third aspect, it has been discovered that the electrosurgical cutting wire may at times cut larger strips of tissue than are easily accommodated by the chopping mechanism for a given probe diameter. It would therefore be beneficial to increase the throughput of the chopping mechanism without having to decrease the quantity of tissue removed with each pass of the resector probe. Finally, it would be best if such improvements could be provided in a probe having the minimum possible weight and system complexity, utilizing existing operating room power systems to minimize costs, facilitate manipulation of the probe by the attending surgeon, and increase the reliability of the resection apparatus.

SUMMARY OF THE INVENTION

In a first aspect, the present invention provides a tissue resection device comprising a handle housing on which a shaft is mounted, the shaft having an aperture adjacent to a distal end and a fluid and tissue aspiration lumen extending from the aperture to a proximal end of the shaft. A cutting member is disposed adjacent to the aperture to sever tissue as the shaft is reciprocated, and an imaging mechanism on the handle housing is oriented toward the cutting member, thereby allowing the attending surgeon to optically direct the removal of body cavity tissue. A chopping mechanism disposed

within the lumen of the shaft reduces the size of tissues passing through the lumen. Generally, irrigation fluid is supplied through a fluid infusion lumen of the housing, while the shaft and cutting member are reciprocatably mounted to the handle housing.

Typically, the cutting member produces strips of tissue, which the chopping mechanism shears into smaller, more easily aspirated tissue fragments as they enter the aperture. Preferably, the imaging mechanism is distally oriented, and the aperture is radially oriented and extends distally of the cutting member. This arrangement allows the removal of tissue strips in the proximal direction toward a fixed viewpoint, and directs the severed tissue into the aperture, thereby minimizing the danger that the probe will inadvertently cut to a greater depth than is intended, and greatly increasing the safety of the resection procedure. Furthermore, directing tissue with aspiration flow into the radially oriented aperture, rather than resorting to an axially oriented endcap, significantly increases cutting depth and decreases cutting drag.

Preferably, the handle housing comprises a sheath which is removably disposed over the shaft, the infusion lumen extending to a distal end of the sheath adjacent to the imaging mechanism. The sheath thus provides an irrigation flow path directed over the imaging mechanism and toward the cutting member. Such an irrigation flow path washes clean, clear irrigation fluid over the critical portion of the field of view of the resection procedure. Generally, the imaging mechanism comprises an optical lens and fiber-optic image guide, although ultrasound or other imaging modalities may be used in some embodiments.

In a particularly preferred embodiment, the tissue resection device of the present invention includes an electrically conductive distal surface disposed distally of the aperture. At least a portion of the electrically conductive surface is distally oriented.

In work done in connection with the present invention, it has been discovered that a resection probe

having a reciprocable cutting member benefits from an alternative mechanism for treating body cavity tissues having surfaces which are generally proximally oriented relative to the axis of the probe. The electrically conductive surface of the present invention allows ablation of such tissues by sweeping the distal end of the probe against the far end of the body cavity. Such a probe is therefore able to treat a greater portion of the interior tissue of a body cavity, without having to resort to multiple, specialized resection probes. Ideally, at least a portion of the electrically conductive surface is within the field of view of the imaging mechanism, thereby facilitating the optical directing of distal tissue ablation.

In a further aspect, the present invention provides a tissue resection device comprising a shaft having an aperture adjacent to a distal end, and a lumen extending from the aperture to a proximal end of the shaft. A cutting member is disposed adjacent to the aperture, and defines a plurality of lobes which simultaneously removing a plurality of tissue strips from a body cavity. Typically, the cutting member comprises an electrosurgical wire having a plurality of loops. Ideally, the outer perimeter of the cutting member is rounded to facilitate removal of a sheath disposed over the shaft proximally of the aperture.

The invention further provides a method for resecting tissue from a surgical site of an internal body cavity, the method comprising cutting strips of tissue from the surgical site by axially translating a cutting member of a probe. Fluid is aspirated from the surgical site and into a radially oriented aperture on a shaft of the probe so that the strips of tissue enter the aperture. The strips are chopped into tissue fragments as they enter the aperture, which tissue fragments are evacuated through the shaft of the probe. Generally, irrigation fluid flows over an imaging mechanism toward the cutting member while optically imaging the tissue and cutting member through the imaging mechanism, and also while cutting the strips of tissue toward the imaging mechanism. Preferably, the cutting member is translated

proximally relative to the imaging mechanism, thereby allowing the strip of tissue to be cut while optically viewing the procedure from a fixed frame of reference.

5 In some embodiments of the method according to the present invention, tissue which is disposed distally of the distal end of the probe is ablated with a distally oriented electrically conductive surface. Generally, the electrically conductive surface is swept over proximally oriented tissues. Alternatively, the electrically conductive surface is rolled
10 over proximally oriented tissue, the electrically conducted surface comprising a rolling element. The electrically conductive surface may conveniently be mounted to the cutting member by removing the cutting member through a sheath from the body cavity.

15 BRIEF DESCRIPTION OF THE DRAWINGS

Other objects, features and advantages of this surgical instrument and accompanying procedure will become more apparent after referring to the following specification and attached drawings in which:

20 Fig. 1A is a perspective view of the drive housing with probe attached illustrating the housing and probe in partial section for understanding of the operative portions of the instrument;

25 Fig. 1B is a perspective of the drive housing H with probe attached illustrating the housing grasped in the hand of the surgeon (shown in broken lines) demonstrating the surgical instrument manipulation of the rigid probe to dispose the elongate aperture at the surgical site, trigger finger
30 manipulation of the cutting head relative to the viewing fiber and ultrasound transducer, and finger actuated aspiration during surgery;

35 Fig. 2A is a section at the distal end of the probe illustrating the rigid shaft, elongate cutting aperture, infusion lumen, electrocautery cutting head, rotating cutting head driving tube with integral aspiration lumen, viewing optical fiber, and ultrasound transducer;

Fig. 2B is a perspective section similar to Fig. 2A with the cutting head removed, and an obturator in place for instrument insertion;

5 Fig. 3A, 3B and 3C are respective sections of a uterus respectively illustrating the probe with an obturator during insertion for surgery, the instrument with rotating shaft and cutting head being inserted to the probe; and the insertion of the optical fiber for completion of the assembled probe;

10 Fig. 4 is a section similar to the sections of Figs. 3A-3C illustrating the working end of the instrument at an operative site;

Fig. 5 is a section similar to Fig. 2A of an alternate embodiment of the probe here illustrated with a conventional cutting head without ultrasound interrogation;

15 Figs. 6A-6C are differing cutting heads utilized with this instrument;

Fig. 7 is a detail of the probe at the point of attachment to the housing illustrating the disposition of the sieve for capture of the chips or morsels from surgery and illustrating how the disposable probe can be shipped (intact or bent) for compact shape for transport for biopsy of the retained chips or morsels;

20 Fig. 8 is a section along lines 8-8 of Fig. 7 illustrating both the perfusion path and the aspiration path together with the relative locations of the probe, rotating tube, and path for the viewing optical fiber;

Fig. 9 is a schematic perspective view of an alternative tissue resection device according to the principles of the present invention;

30 Fig. 10 is a detailed cut-away side view of an exemplary tissue resection device patterned according to the schematic of Fig. 9;

Fig. 10A is an enlarged cross-sectional view of the distal end of the tissue resection device of Fig. 10.

35 Fig. 11 is a detailed side view of an alternative embodiment of the device of Fig. 10 with an angled electrocautery loop;

Fig. 11A is a front end view of the device of Fig. 11;

Fig. 12 is an alternative embodiment of the device of Fig. 11 employing a wire director for directing removed tissue into the chopping mechanism;

Fig. 12A is a front end view of the device of Fig. 12;

Fig. 13 illustrates an alternative embodiment of the device of Fig. 12 with the optical scope and the ultrasonic transducer being separated;

Fig. 13A is a front end view of the device of Fig. 13; and

Fig. 14 illustrates an exemplary method for resecting tissue from the uterus using the device of Fig. 12.

Fig. 15 is a perspective view of a resection probe according to the principles of the present invention, showing the proximal handle and several of the probe system connections.

Fig. 16 illustrates a resection probe system, including the probe of Fig. 15.

Fig. 17 illustrates the flex drive connection and the aspiration and irrigation flow paths for the probe of Fig. 15.

Fig. 18 illustrates a method of use of the probe of Fig. 15 for trans-cervical fibroid removal from the uterus.

Figs. 19 and 19A illustrate the axial cutting motion of the cutting member and chopping mechanism, and also show the irrigation and aspiration fluid flow paths at the distal end of the probe of Fig. 15.

Figs. 20A through 23B illustrate alternative cutting members for use with the probe of Fig. 15.

Figs. 24 through 27 illustrate distally oriented electrically conductive surfaces for use with the probe of Fig. 15.

DETAILED DESCRIPTION OF THE SPECIFIC EMBODIMENTS

Referring to Fig. 1A, surgical probe P is shown mounted to housing H. In understanding this invention, the probe P will first be discussed with respect to the preferred embodiment of Fig. 2A and 2B. Thereafter, the construction and operation of the probe from drive housing H in the hand of a surgeon will be discussed. Finally, alternate embodiments of the probe and cutting head as well as the capture of chips or morsels from the surgical site within the detachable probe will be set forth.

Referring to Fig. 2A and 2B, probe P is illustrated only at its distal and surgical end. Probe P is rigid having a blunted forward end 14 with an enlarged end 16 for fully accommodating the section of cutting head C. Exposure for surgery of cutting head C occurs at elongate slot 18 with view of the cutting head C during surgery within slot 18 being provided by optical fiber F at the proximal end of the slot. In Fig. 2B, probe P is disclosed occupied by obturator O. It is in this mode that probe P is inserted.

An electrocautery cutting head C is provided. Head C includes electrically conductive cutting edges 20 which are radially exposed from the cutting head C for surgical resection when head C is rotated in the direction of arrow 22. Head C is hollow and communicates to rotating driving tube 30 with interior aspiration lumen 25. An ultrasound transducer T rotates with cutting head C and sends and receives acoustical signals through wire 35. This transducer can measure remaining uterine wall thickness immediately after surgery when head C is in elongate slot 18 drawn proximally or distally of elongate slot 18 or at any intermediate position with respect to the slot.

Cautery alone utilizing probe P can occur. Specifically, by rotating cutting head C opposite to arrow 22, electrocautery cutting heads 20 pass in a blunted and non incisive path over the flesh. Cautery results.

Having generally discussed the construction of the probe, attention can now be directed to handle H.

Referring to Fig. 1A, handle H includes DC motor 40 electrical connections 42-- it being recognized that reversal in motor polarity causes reversal in motor direction. Electrocautery connection is routed via a standard cautery power supply through conduit 41 to a journal bearing connection (see Fig. 1A). Acoustical transducer T (seen in Fig. 2A) at cutting head C sends and receives electrical signals through lead 43. A conventional slip coupling-- not shown-- is provided to wire 35 in tube 30 to lead 43.

Motor 40 is mounted to plate 45 and provides driving rotation at toothed pulley 47. Belt 46 drives toothed pulley 48 which in turn rotates drive tube 30 through quick disconnect coupling 125. This quick disconnect coupling is the point of removable attachment of the probe. (See Fig. 7)

Drive tube 30 is of constant length. Forefinger trigger 50 attaches directly to plate 45 which is mounted for sliding translation interior of handle H. By movement of trigger 50 relative to housing H, corresponding movement of cutting head C occurs along elongate slot 18. Video camera coupler 55 communicates to fiber F having illumination strands for viewing of the applicable surgery.

Referring to Fig. 1A, the fluid circuit for maintaining uterine cavity distention is only illustrated in pertinent part. It is presumed that standard technology will be used to maintain required pressure for uterine cavity distention through inlet conduit 61. Inlet conduit 61 communicates to probe P in the infusion lumen 62. By maintaining a constant pressure sufficient to establish uterine distention, required inflation is maintained in the organ-- here the uterus-- in which the operation occurs.

Referring to Fig. 7, fluid exits the site of the surgery through lumen 25 in rotating tube 30 and passes to chamber 130 where chips or morsels from surgery are captured. Thereafter, aspirated fluid passes through conduit 65 to finger actuated valve 66 and thence to state of the art fluid capture apparatus. As is customary in such procedures, chips or morsels are routed to pathology for investigation including biopsies where required. The instrument may be shipped intact

or be bent (as at shaft 30) for convenience. Disposal can thereafter occur.

Referring to Fig. 1B, the surgical ergonomics of housing H can be appreciated. Taking the case of a right handed surgeon, housing H at bottom surface 70 is held by hand S with thumb 72 opposing the third, fourth and fifth fingers 74, 75 and 76. Forefinger 73 grips trigger 50 and by movement of finger 73 relative to housing H causes inward and outward traverse of cutting head C relative to elongate slot 18 of probe P. Middle finger 74 depresses valve 66 to cause applicable aspiration for example when view from eyepiece 55 indicates obstruction. Thus, flushing of sorbitol-mannitol solution distending the uterus can occur at intermittent and successive intervals as required by the surgical procedure.

Insert of the instrument is easy to understand. Referring to Fig. 3A, probe P with obturator O is inserted to uterus U. Thereafter, obturator O is withdrawn, and housing H with cutting head C threaded (See Fig. 3B). Once this insertion is made, fiber F is thereafter inserted for visualization of the surgical site (See Fig. 3C and the section of Fig. 8). Operative movement of the instrument can thereafter occur as illustrated in Fig. 4.

The instrument in use can be visualized in the uterine section of Fig. 4. Probe P is shown with blunt end 14 within uterine cavity 80. This cavity is flooded with sorbitol-mannitol solution 82 so as to dispose lining L for surgery. In the preferred method, cutting head C is disposed at C'. Under the guidance of fiber F, probe P is maneuvered to surgical site. Assuming resection, cutter head C is drawn proximally of elongate slot 18 in probe P. With the preferred construction illustrated in Fig. 4, three occurrences follow.

First, and starting with cutting head C distally of elongate slot 18, view of the tissue before resection is provided. Secondly, and with traverse of cutting head C, surgical resection occurs. Thirdly, and immediately in the wake of the required resection, acoustical transducer T interrogates uterus U immediately after the surgery.

It will be remembered that evacuation of fluid occurs directly from the cutting edges of cutting head C to rotating tube 30 with its aspiration lumen 25. Accordingly, flushing of chips and morsels is immediate the surgical site 90 with minimal chance for clouding the required view through fiber F.

Referring to Fig. 5, an alternate embodiment of cutting head C" is illustrated. Cutting head C" is hollow, attached to rotating tube 30', and included semi-spherical cutting edges 21. It will be noted that this head does not include acoustical transducer T nor does it include electrocautery. While both these features are preferred, they are not required.

It is to be understood that acoustical interrogation of uterus U immediately after surgery is not trivial. Specifically, and during the illustrated procedure utilizing operating tools and procedures of the prior art, one of the most difficult assignments of the surgeon is not to cut entirely through the uterus. Such cutting causes morbidity such as iatrogenic uterine perforation and can damage nearby body structures such as bowel.

Fortunately, soft tissue organs such as uterus U can be acoustically interrogated for their remaining wall thickness after resection. Thus transducer T can output through conventional acoustical visualizing apparatus the thickness remaining of the organ. Additionally, and with a conventional shaft encoder, an acoustical section or well known "B" scan of the section at the angle of view of the transducer can be displayed. For example, the remaining width when below a predetermined thickness can be utilized with its telltale acoustical signal to trigger an alarm warning the surgeon when remaining thickness is below a set tolerance.

It will be apparent that the tool of this application will admit of a number of differing cutting heads. For example, as indicated in Fig. 6A, it may be desired to have the cutting head end in a V-shaped cutting profile 101. Further and as set forth in Fig. 6B, and with modification to the probe, a rotating U-shape cutter 102 may be required for

distal or end-on access to surgical sites. Finally, and as set forth in Fig. 6C, a flat cutter 103 is shown. It will be realized that this invention will admit of other shapes. Further, the respective cutting heads can either be
5 conventional knives or be provided with suitable paths for electrocautery.

Referring to Fig. 7, the aspiration of fluid from the surgical site together with the trapping of morsels from surgery from the aspirated fluid can be understood. First,
10 perfusion fluid is introduced through conduit 61 into perfusion chamber 100. It then enters probe P.

Viewing Fig. 8 at this juncture can be instructive. Specifically, bearing member 102 with fiber F and rotating tube 30 receiving concavities is placed interior of probe P
15 and extends almost the full length of the lumen within probe P. It includes a lower round aperture 107 which is the surface against which rotating shaft 30 bears. The upper surface forms a saddle which locates and guides the viewing scope F which may be flexible. The remaining interior volume
20 of probe P forms a channel which contains the perfusion fluid. Exit of the fluid occurs through slot 18 and the end of probe P.

Rotating shaft 30 extends completely through chamber 100 and into and through a housing defining chamber 130. Chambers 100 and 130 may be separated by an O-ring (See Fig.
25 7) or other suitable seal. It is in this housing that the morsels from surgery are trapped. Thereafter, shaft 30 terminates at a quick disconnect coupling 125 which couples to a counter part coupling member 126 driven by motor 40. (See
30 Fig. 1B for this detail).

Interior of chamber 130, shaft 30 is provided with an aperture 128. Aperture 128 allows aspirated fluid to be communicated to chamber 130. Aspirated fluid is withdrawn
35 from chamber 130 through conduit 65. Conduit 65 communicates through valve 66 and outflow conduit 67 for the discharge of aspirated fluid. (See Fig. 1B for valve 6 and conduit 67)

Screen 135 divides chamber 130 between aperture 128 (which rotates with shaft 30) and conduit 65. As a

consequence, morsels from surgery are trapped on screen 135. This being the case, the attached probe P when removed from handle H can constitute both a disposable appliance as well as a convenient cartridge 64 for transport of surgical morsels for biopsy. (See Fig. 1A and 7)

As is apparent, the disposable portion of the device may or may not include probe P.

As a known alternative to the cautery illustrated herein, heated fluids can be flowed through the instrument to coagulate the tissue.

The preferred and illustrated application of this design is for trans-cervical fibroid removal, removal of myometrium, and removal of endometrium. Other uses of instruments substantially incorporating this design are listed below:

Intrauterine (Hysteroscopy)

Uterine wall Resection

Endometrial Ablation

Endometrial Resection

Submucous Myoma Resection

Intramural Myoma Resection

Transmural Myoma Resection

Resection of Cervix and Cervical Canal

Kidney Resection (Laparoscopy)

Retroperitoneal

Prostate Resection (Cystoscopy)

Intra-abdominal (Laparoscopy)

Uterine Myomectomy

Ovary Resection

Lung tissue and Tumors (Thoracoscopy)

Measuring Device (Ultrasonic Transducer)

Uterine Wall Thickness

Endometrium Thickness

Prostate Thickness

Intra uterine measurements

Urethra thickness

The above procedures may require relatively minor modifications of the disclosed device.

The invention provides an alternative embodiment of a tissue resection/ablation device 200. The device 200 is illustrated schematically in Fig. 9. While the device 200 is particularly advantageous for trans-cervical fibroid removal, removal of myometrium, and removal of endometrium, the device 200 may find other uses including those previously listed above and further including joint arthroscopy. For purposes of convenience, the device 200 will be described with reference to treatment of the uterus. However, the invention is in no way limited to only this type of application.

The device 200 includes an electrosurgical member 202 that is shown schematically in the form of an arch. The electrosurgical member 202 can conveniently be formed from an electrically conductive wire, metal strip, or the like, and can be fashioned in any shape depending on the particular application. Fashioning in the form of an arch is advantageous when removing fibroid tissue from the uterus because strips of tissue can rapidly be removed by translating the electrosurgical member 202 through the tissue. Current is provided to the electrosurgical member 202 through a wire 204 which is in turn connected to an electrosurgical unit.

When electrosurgically removing tissue using prior art methods, the surgical site within the uterus rapidly fills with debris created from the removed tissue. Removal of this debris becomes imperative to allow the surgeon to maintain a clear view of the operation site. Prior art attempts to remove such debris include "sweeping" away the debris between cutting strokes, and periodically removing the electrosurgical device from the uterus to flush or suction away the debris. In the present invention, the removed tissue is immediately evacuated from the uterus by directing the tissue strips from the electrosurgical member 202 and into a chopping or severing mechanism 206. The chopping mechanism 206 in turn rapidly reduces the size of the tissue strips so that the tissue can be suctioned through the device 200 and removed from the uterus. In this way, tissue removed by the electrosurgical member 202 is evacuated from the surgical site as rapidly as the surgeon can cut the tissue. The amount of debris created

in the uterus is drastically reduced, and the time consuming steps of "sweeping" away tissue or removing the electrosurgical device from the uterus for flushing or suction is eliminated.

5 The tough and gristly nature of fibroid tissue makes it difficult to remove from the uterus with conventional knife-edged instruments. Use of the electrosurgical member 202 has proven to be effective in such removal. However, once removed by the electrosurgical member 202, the fibroid tissue becomes easier to process, and a conventional arthroscopic cutter can be employed to chop or severe the tissue into smaller morsels. Suitable arthroscopic cutters are described in U.S. Patent Nos. 4,274,414 and 4,203,444, the disclosures of which are herein incorporated by reference. Briefly, such cutters include a rotating concentric tube having a shaving port into which the tissue is directed. The rotating blade chops the fibroid tissue into small transportable morsels or chips which can then be removed from the uterus through the concentric tube by suction. Although such cutters are preferred, a variety of different chopping mechanisms can be employed including reciprocating blades, grinders, and the like, a necessary requirement being that the mechanisms chop, severe or reduce the tissue into smaller morsels for evacuation. A motor 208 is provided to rotate the chopping mechanism 206. The motor 208 further includes a vacuum valve and an associated vacuum port for providing suction to remove the chopped tissue from the uterus.

To assist in directing the strips of tissue removed by the electrosurgical member 202 towards the chopping mechanism 206, an end cap 210 is provided just distal to the electrosurgical wire 202. In this way, tissue removed when translating the electrosurgical member 202 is directed by the end cap 210 into the chopping mechanism 206. The chopping mechanism 206 in turn chops the tissue as it is fed from the end cap 210 so that substantially all tissue removed by the electrosurgical member 202 is chopped and removed from the uterus. Operation of suction and motor 208 without electrocautery allows the device 200 to extract loose floating

debris that may have escaped the initial cutting/extraction process.

Visualization of the surgical site while removing tissue can be provided by an ultrasonic transducer 220 disposed near the electrosurgical member 202. The ultrasonic transducer 220 provides information on the thickness of the uterine wall where the fibroid material is being removed. By monitoring uterine wall thickness in this way, removal of fibroid material can be halted before perforating and damaging adjacent structures such as the bowel or bladder. The ultrasonic transducer determines wall thickness as previously described with transducer T. Briefly, a pulse signal is sent through the uterine wall and the time required to receive a return pulse is measured. Based on this measurement, the thickness of the uterine wall can be calculated. This information can be viewed on a conventional oscilloscope screen, or the thickness can be displayed numerically. To map the area of the uterine wall near the area where the desired cut is to be made, a plurality of such measurements are made. Based on this information, the surgeon can estimate the appropriate depth for the entire length of the cut. Instead of displaying the result of each individual measurement on a oscilloscope screen or displaying a numeric value, a "B" scan can be made and entered into a processor to produce a visual image of the uterine wall. The visual image can then be evaluated to determine the appropriate depth for the cut.

The ultrasonic transducer 220 can be used independently of the electrosurgical member 202, e.g., by removing the electrosurgical member 202 or by not actuating it, as a diagnostic tool. When used as a diagnostic device, the transducer 220 is used to map the a body organ from within the organ. For example, the transducer can be positioned within the endometrial cavity of the uterus and actuated to map the endometrial cavity and the uterine wall. In this way, abnormalities in the uterus can be diagnosed.

Visualization of the surgical site during operation of the electrosurgical member 202 can also be provided by a fiber optic scope 222 near the electrosurgical member 202.

The fiber optic scope 222 provides conventional visual feedback through an eyepiece 224 to which a video camera is commonly coupled for display on a video monitor and for creating a tape record of the procedure. The fiber optic scope 222 and the ultrasonic transducer 220 can be used separately or can be used together to provide both conventional optical visualization and ultrasonic visualization of uterine wall thickness.

The tissue resection device 200 will usually be introduced into the cervix through a sheath 226. To facilitate introduction of the sheath 226, an obturator is usually first inserted into the sheath 226. Once the sheath 226 is inserted into the uterus, the obturator is removed from the sheath 226 and the device 200 is inserted into the sheath 226. The sheath 226 provides a working channel through which the electrosurgical member 202, the chopping mechanism 206, the fiber optic scope 222, the ultrasonic transducer 220, and other components of the device 200 can be inserted. When the components of the device 200 are introduced into the sheath 226, a seal is formed between the components of the device 200 and the sheath 226 (see Fig. 10). In this way, irrigation fluid can be applied through an irrigation tube 228 to distend the uterus before tissue removal, and to make up for fluid used in the extraction process.

Referring to Fig. 10, an exemplary embodiment of a tissue resection device will be described. The device of Fig. 10 is patterned after the schematic of Fig. 9. For purposes of convenience, the embodiment shown in Fig. 10 will use the same reference numerals as used to schematically describe the tissue resection device 200 in Fig. 9. The device 200 includes an elongate body 212 having a distal end 214 and a proximal end 216. The elongate body 212 houses the chopping mechanism 206 and holds the electrosurgical member 202 in a fixed position relative to the chopping mechanism 206. To position the elongate body 212 and the fiber optic scope 222 within the sheath 226 (shown cut away to illustrate positioning of the components), a guide 230 is provided within the sheath 226. (For purposes of clarity, the irrigation

lumen 228 and wire 204, which pass through channels in the guide 230, have been omitted.) The guide 230 is slidable within the sheath 226 and also provides a seal between the components and the sheath 226 so that distention pressure can be maintained inside of the uterus during operation. The guide 230 is preferably constructed of plastic, but can alternatively be constructed of a variety of other materials including stainless steel, brass, aluminum, and the like. The guide 230 is preferably permanently fixed to the outside of the elongate member 212 and includes O-rings 232 and 234 for sealing the guide 230 to the sheath 226 and scope 222. The sheath 226 will be preferably constructed of stainless steel which can be sterilized and reused.

The electrosurgical member 202 will preferably comprise an electrosurgical wire that is formed into a loop, an arch, or other suitable geometry. The electrosurgical wire 202 is attached to the outside of the elongate body 212 and is positioned above an aperture 218 in the elongate body 212 which provides access to the chopping mechanism 206. The end cap 210 is fixed to the distal end 214 of the elongate body 212 so that strips of tissue removed by the electrosurgical wire 202 are directed by the end cap 210 into the aperture 218.

An electrically conductive area 236 (or plurality of areas) is provided on the outside surface of the end cap 210 that can be connected to the same electrosurgical unit used to provide current to the electrosurgical wire 202. When actuated, the electrically conductive area 236 can be applied to bleeding tissue to promote coagulation to stop bleeding or can be used for endometrial ablation. When used for ablation, the end cap 210 will preferably be constructed of a ceramic, and the electrically conductive area 236 will preferably be a metallic surface on the cap 210 that is connected by a separate wire to the electrosurgical unit.

The elongate body 212 includes a central lumen 237 extending between the distal end 214 and proximal end 216. Held within the lumen 237 is the chopping mechanism 206. As shown best in Fig. 10A, the chopping mechanism 206 will

preferably include a concentric rotating tube 240 disposed within the lumen 237. A shaving port 238 is formed in the wall of the tube 240 and is generally aligned with the aperture 218 of the elongate body 212. An edge 239 of the shaving port 238 and an edge 241 of the aperture 218 are sharpened so that any tissue drawn through the aperture 218 and shaving port 238 are sheared upon rotation of the concentric tube 240. In Fig. 10A, the rotating tube 240 is shown with the shaving port 238 facing away from the aperture 218. The triangle area TR is an opening between the edges 239 and 241. As the tube 240 is rotated, the edge 239 of the shaving port 238 is translated across the edge 241 of the aperture 218 until the triangle area TR disappears. Any tissue extending through both the shaving port 238 and the aperture 218 is sheared by the edges 239 and 241. Upon each revolution of the tube 240, another morsel of tissue is sheared.

The concentric tube 240 is rotated by the motor 208 (not shown) held within a housing 242. The housing 242 includes vacuum ports for connection to a house vacuum and associated vacuum valves for regulating suction. The suction is applied through the tube 240 thereby allowing the chopped morsels to be evacuating from the uterus.

In an alternative embodiment, the electrosurgical wire 202 can be slidably mounted on the elongate body 212, and a trigger mechanism can be used to axially translate the wire 202 in a smooth and controlled manner along the body 212. In this way, the wire 202 is translated relative to the scope 222.

The eyepiece 224 includes a viewing element 244 and an illumination connector 246. When the illumination connector 246 is attached to a suitable light source, light is provided to the optical fiber within the scope 222. This allows a surgeon to look through the viewing element 244 and visualize the operation site near the electrosurgical member 202. The ultrasonic transducer 220 is disposed on top of the optical scope 222 and is positioned so that its field of view includes the operative area above the electrosurgical

wire 202. In this manner, the operative area where tissue is being removed by the electrosurgical wire 202 can be optically viewed by the scope 222 and the wall thickness can ultrasonically be visualized by the transducer 220. The optical scope 222 is slidably held within the guide 230 so that scope 222 can be axially translated to adjust the viewing area of both the scope 222 and the ultrasonic transducer 220. In an alternative embodiment, the ultrasonic transducer 220 can be provided on a separate instrument that is inserted parallel to the scope.

An important feature of the resection device 200 is that a variety of electrosurgical wire/end cap/chopper configurations can be employed to provide greater flexibility and effectiveness in treatments. One such alternative embodiment is the tissue resection device 200' shown in Figs. 11 and 11A. The tissue resection device 200' is essentially identical to the tissue resection device 200 except for the end cap and the positioning of the electrosurgical wire. In the resection device 200' an electrosurgical wire loop 202' is angled toward the distal end 214 of the elongate body 212, preferably at any angle relative to the elongate body 212. Alternatively, the loop 202' can be angled away from the distal end 214 at any angle. Angling of the wire 202' toward the distal end 214 is advantageous when treating difficult to reach areas such as the top of the uterus. An end cap 210' is correspondingly angled so that the end cap 210' does not interfere with the cutting performance of the wire 202'. As with the previous embodiment, the end cap 210' serves as a director for directing tissue into the chopping mechanism 206.

Referring to Figs. 12 and 12A, a further embodiment 200" of the tissue resection device 200 will be described. The resection device 200" is essentially identical to the tissue resection device 200' described in Fig. 11 except for the configuration of the end cap 210'. In the tissue resection device 200", an end wire 250 is provided at the distal end 214 of the elongate body 212. Use of the end wire 250 is advantageous in that it allows an optical viewing

path for the optical scope 222 beyond the distal end 214 of the device 200". This allows for viewing of the area where the device 200" is being positioned in preparation for a cut. Fig. 12A represents a view from the distal end 248 of device 200". Although the view is partially blocked by the end wire 250 and the electrosurgical wire 202, sufficient space is provided between the wires so that a surgeon can view beyond the distal end 214 when looking through the eyepiece 224. A shell 252 is welded or bonded to the elongate body 212. Along with the end wire 250, the shell 252 serves to direct removed tissue into the chopping mechanism 206. The shell 252 can optionally be provided with electrically conductive areas which can be used to cauterize or thermally ablate tissue as previously described.

As shown in Fig. 12, the ultrasonic transducer 220 is included on the optical scope 222. Alternatively, as shown in Figs. 13 and 13A, ultrasonic transducer 220 can be held in a shaft 260 separate from the optical scope 222. In such a configuration, the optical scope 222 will preferably be a 2 mm optical scope that is aligned with an aperture 256 in the end wire 250 so that optical visualization can occur beyond the distal end 214. Both the shaft 260 and the scope 222 are slidable within the sheath to allow the optical scope 222 and the ultrasonic transducer 220 to be adjusted independently of one another.

Referring to Fig. 14, an exemplary method for using the tissue resection device 200" will be described. Although described in the context of the device 200" for convenience, the method can also be used with the previously described embodiments of the tissue resection device 200 and 200'. Initially, the sheath 226 is inserted into the uterus using an obturator (not shown) as previously described. The obturator is then removed and the device 200" is inserted into the sheath 226. Once a seal is formed between the sheath 226 and the guide 230, fluid is introduced into the uterus 254 for distention. While optically and/or ultrasonically viewing the uterus 254 with the fiber optic scope 222 and/or the ultrasonic transducer 220, current is delivered to the

electrosurgical wire 202 and the wire 202 is translated along the lining of the uterus 254 as indicated by arrow 256. Alternatively, before commencing a cut, the ultrasonic transducer 220 can be actuated to survey and map the thickness of the uterus in the desired treatment area.

5 The wire 202 is translated by sliding the device 200" within the sheath 226. As the wire 202 is translated, strips of tissue are removed and directed to the chopping mechanism 206 by the end wire 250 and shell 252. The removed strips of tissue are then chopped into smaller morsels by the chopping mechanism 206 as previously described. After the completion of the first cut, the surgeon directs the electrosurgical wire 202 to an adjacent area and draws the wire through the fibroid. With the completion of each cut, 10 the wire 202 is repositioned and another cut is begun. The amount of material removed is controlled by the manually maneuvering, e.g., lifting or pivoting, the device 200" to adjust the depth of penetration of the wire 202 into the uterus and by the length of the cutting stroke.

20 In this way, strips of removed tissue are automatically directed into the chopping mechanism 206 for removal from the uterus. This reduces the time and effort normally incurred in removing shavings which block the field of view of the surgeon. Further, since the device does not need to be withdrawn from the uterus 254 to remove the shavings, the task of reorienting the device 200" is eliminated. Fatigue is also reduced which allows the surgeon to perform more precise work.

30 Referring now to Fig. 15, resection probe 310 generally has a proximal end 312 and a distal end 314. A probe shaft 316 supports a cutting member 318 near its distal end. Fiber-optic imaging scope 320 is distally oriented toward cutting member 318, and runs proximally within sheath 35 322.

A probe handle housing 324 includes an actuation handle 326 for axially translating the shaft and cutting member relative to the sheath. An irrigation fluid port 328

and aspiration port 330 provide a continuous flow path for a clear, non-conductive fluid such as sorbitol-mannitol, mannitol, glycine, or the like. Aspiration flow is controlled by an aspiration valve 332, so that the distension pressure may be maintained independently from flow. Electrosurgical connector wires 334 and a flex drive input 336 provide external electrical and mechanical power, minimizing the weight of housing 324. An optical image eyepiece 338 is removably attached to housing 324 to optically direct the resection procedure. Optionally, an ultrasound transceiver may be mounted on the distal end of the probe as is more fully explained above. Such a distal ultrasound transducer may optionally comprise a one- or two-dimensional phased array to allow scanning of the resection tissue independent of any mechanical movement of the transducer probe.

Referring now to Fig. 16, a resection system 340 utilizes the input and output connectors on the housing of probe 310, together with standard stand-alone surgical system components to minimize cost, weight, and fatigue when using probe 310 in a resection procedure. An irrigation supply 341 is connected to irrigation port 328 to provide a continuous flow of irrigation fluid during resection. Preferably, irrigation supply 341 comprises a standard irrigation supply bag suspended above the surgical site to provide a constant pressure gravity feed, allowing distension pressure to be varied simply by changing the height of the irrigation supply. Alternatively, a valve or controlled flow pump may be used to supply irrigation fluid.

In the exemplary embodiment, aspiration, mechanical rotation, and electrosurgical potential are coupled to the shaft through a disposable cartridge 325 on shaft housing 324, the disposable cartridge reciprocating with the shaft as shown. Fluid which leaves aspiration port 330 is directed through a filter canister 342 and then to an aspiration sump 344. Filter 342 removes the solid tissue fragments from the aspiration fluid for analysis. Sump 344 is preferably connected to a standard vacuum supply line to promote the withdrawal of aspiration fluid through the probe. Aspiration

vacuum control is conveniently provided by aspiration valve 332 (see Fig. 15).

Mechanical power is supplied to flex drive input 336 by drive motor 348. Drive motor 348 preferably rotates at least in the range between 500 and 1500 rpm, and typically allows for rotation in either direction, or oscillating rotation back and forth. The chopping mechanism generally shears tissue mechanically, without requiring electrosurgical potential.

Controlled electrosurgical power is supplied through electrosurgical wires 334 to the cutting member by power unit 346. A switch (not shown) allows application of electrosurgical power to instead be directed to a distally oriented conductive surface, as described hereinbelow.

Referring now to Fig. 17, irrigation fluid supplied to irrigation port 328 enters the probe at a sheath coupler 350, and then flows distally through an infusion lumen of sheath 322. The sheath ends proximally of the distal end of shaft 316 so that the irrigation fluid flows outward into the body cavity, generally washing distally over the scope 320 and cutting member 318. The aspiration flow path enters shaft 316 at an aperture 354, also entering a shaving aperture 356 near the distal end of a chopping tube 358. Chopping tube 358 rotates within shaft 316 so that aperture 354 and shaving port 356 shear tissue fragments from the strips which are directed into aperture 354.

The aspiration flow path exits chopping tube 358 at a proximal flow port 360, and flows into an internal cavity of disposable cartridge 325. Flex drive input 336 rotates the chopping tube by means of a drive pin 362. The drive shaft, connector wires, and aspiration hose reciprocate with disposable cartridge 325 and shaft 316, and flex easily to allow manipulation of the probe. An optical image eyepiece adapter 364 is removably mounted to proximal housing 324 with a thumbscrew 368. Optical adapter 364 typically allows connection of an illumination source, video cameras for viewing and/or recording of the resection procedure, and the like.

Referring to Fig. 18, an exemplary method for using resection probe 310 typically comprises trans-cervically introducing sheath 322 into the uterus U. Such insertion is facilitated by use of an obturator. Sheath 322 is preferably rigid, ideally comprising a composite insulating material such as fiberglass or the like. Manipulation of the probe is facilitated by limiting the sheath to a maximum of about 327 Fr (about 9 mm in diameter). Once the sheath is properly positioned, the obturator is removed and the shaft 316, cutting member 318, and the scope 320 are inserted through the shaft and proximal housing 324 is attached to sheath coupling 350.

The probe is manipulated from the proximal housing 324 using articulation handle 326. The surgeon inserts the fingers of one hand through finger handle 370 and inserts the thumb of the same hand through thumb ring 372. Preferably, the fingers are held stationary while the thumb ring extends the shaft and cutting member distally from the sheath. Thumb ring 372 is biased toward the proximal direction, so that removal of strips of tissue actually take place under the assistance of biasing spring 373.

Removal of fibroid tissue from the uterus U begins with the cutting member 318 extended distally from the sheath 322. As illustrated in Fig. 18, the shaft is generally aligned with the tissue to be removed so that proximally actuating thumb ring 372 draws cutting member 318 through the fibroid tissue. The procedure is directed using scope 320, preferably while the scope and sheath are held substantially motionless using finger handle 370. Performing each cut towards the viewing optics helps to avoid inadvertently perforating uterus U, the cutting member defining a maximum depth of the cut. However, proximally oriented tissues 376 cannot easily be cut by such a proximal translation, while limiting the direction of the cut also limits the ability of the probe to remove axially oriented tissue 378 which is near the far end of the cavity.

To allow probe 310 to provide therapy for substantially all fibroid tissues in uterus U, the distal end

of shaft 316 includes a distally oriented electrically
conductive surface 374. Conductive surface 374 is energized
by the same electrosurgical power unit as is used for cutting
member 318. Preferably a switch allows selection of either
5 one the other electrosurgical surfaces. Conductive surface
374 is swept back and forth over proximally oriented fibroid
tissue 376 and adjacent axially oriented tissue 378, ablating
these tissues without cutting or puncturing the wall of the
uterus.

10 In an alternative embodiment of the present method,
the surgeon may manipulate the thumb ring relative to the
finger handle to bring the cutting member 318 to a preferred
distance from scope 320, at which the scope provides the
optimum field of view. The thumb and fingers are then held
15 fixed relative to each other, and the shaft and housing
assemblies are withdrawn proximally from the body cavity.
This provides a longer cutting stroke for cutting member 318,
and decreases the time required for the resection procedure,
particularly when removing tissue from the uterus which is
20 generally axially longer than a single stroke of the handle.

Referring now to Fig. 19, the orientation and flow
of aspiration flow path 380 over the imaging fiber-optics 320
is illustrated. In the exemplary embodiment, the proximal
ends of cutting member 318 are disposed within insulated tubes
25 which are soldered to shaft 316, the tubes and shaft being
insulated with shrink-wrap tubing 382. Optionally, the
shrink-wrap tubing extends distally onto the angled portion of
cutting member 318 to direct the irrigation fluid flow 380
toward the tissue being cut. Regardless, the use of
30 aspiration flow path to direct the strips of tissue into
aperture 354 of shaft 316 leaves the distal end of the shaft
with no protruding structure to interfere with the depth of
tissue being cut, or to obscure the view beyond the distal end
of the shaft. The interaction of shaving port 356 on chopping
35 tube 358 with the aperture 354 of shaft 316 is also clearly
seen. An end view of these features is shown in Fig. 19A.

Figs. 20A and 20B illustrate an alternative cutting
member 384 having a reduced diameter cutting lobe 386. As can

be understood with reference to Fig. 19A, it has been discovered that the cutting member is capable of cutting strips of fibroid tissue which are larger than are easily accommodated by aperture 354 on shaft 316. Reducing the lobe size facilitates the chopping of the strip of tissue and evacuation of tissue from the surgical site. However, reduced diameter lobe 386 also decreases the amount of tissue removed with each pass of cutting member 318, and therefore prolongs the surgical procedure.

Figs. 21A and 21B illustrate a still further alternative cutting member 388 having a loop 390 which defines a loop lobe and a second lobe 392. Each of these two lobes cuts a separate strip of tissue when alternative cutting member 388 is passed through tissue. These two smaller strips of tissue are more easily accommodated by aperture 354 and therefore increase the speed of tissue removal.

As illustrated in Figs. 22A and 22B, still further alternative cutting members are possible. Squared cutting member 394 includes a squared loop 396. Three-lobed cutting member 398 includes a central loop 400. It should be appreciated that more than three lobes may also be used, within the scope of the present invention. In general, rounded corners 402 increase the total amount of tissue which can be removed by a cutting member which must fit within a round shroud, as seen in Fig. 19A. Finally, it will be understood that a variety of angles may be used between the cutting member and the probe shaft. Advantageously, a right angle cutting member as illustrated in Figs. 21A and 21B is in a single focal plane as viewed from the fiber-optic image lens, and therefore helps to ensure accurate optical direction of the resection procedure.

Alternative electrically conductive distal surfaces are illustrated in Figs. 24-27. A rounded conductive surface 410 facilitates sweeping of the distal end of the shaft 316 over proximally oriented tissues to ablate tissues which are not easily accessible to cutting member 318. Rounded conductive surface 410 also extends upward into the fiber-optic imaging field of view, and may be used to cauterize

blood vessels left bleeding by cutting member 318. However, the electrically conductive surface should not protrude upwards so far as to interfere with the cutting depth of cutting member 318. In some embodiments, upward protruding electrically conductive surfaces may be resiliently mounted, for example, on the distal end of a spring wire 415 as shown in Fig. 26, allowing the electrically conductive surface to flex out of the way, thereby avoiding interference with the depth of cut.

10 Ablation of tissue may be further facilitated by forming the electrically conductive surface as a roller. Such a roller may be located adjacent to the shaft 412, or may alternatively comprise a raised roller 414. To avoid interfering with the depth of tissue resection, a detachable raised roller 416 might be mounted on cutting member 318 by removing the shaft and cutting member through sheath 322. This allows the electrosurgical wires which supply power to the cutting member to also power the ablation or coagulation processes using the electrically conductive surface.

15

20 Alternatively, the electrically conductive surface may be mounted on the shaft 316 and may be powered by energizing shaft 316 with the proper electrosurgical current. In some embodiments, the distal end of shaft 316 itself forms the electrically conductive surface. Clearly, it is also possible to provide separate electrical lead wires.

25

Although the foregoing invention has been described in detail by way of illustration and example, for purposes of clarity of understanding, it will be obvious that certain changes and modification may be practiced in the scope of the appended claims.

30

WHAT IS CLAIMED IS:

- 1 1. A tissue resection device comprising:
2 a handle housing;
3 a shaft mounted to the housing, the shaft having a
4 proximal end, a distal end, an aperture adjacent the distal
5 end, and a fluid and tissue aspiration lumen extending from
6 the aperture to the proximal end;
7 a cutting member disposed adjacent to the aperture
8 to sever tissue as the shaft is reciprocated;
9 an imaging mechanism on the housing oriented toward
10 the cutting member; and
11 a chopping mechanism disposed within the lumen of
12 the shaft to reduce the size of tissue passing through the
13 lumen.
2. A tissue resection device as claimed in claim
1, wherein the shaft is reciprocatably mounted to the housing.
- 1 3. A tissue resection device as claimed in claim
2, wherein the aperture extends distally of the cutting
3 member, and wherein the imaging mechanism is distally
4 oriented.
- 1 4. A tissue resection device as claimed in claim
2, wherein the housing comprises a sheath removably mounted
3 over the shaft, wherein a fluid infusion lumen extends through
4 the sheath to a distal end of the sheath adjacent to the
5 imaging mechanism.
- 1 5. A tissue resection device as claimed in claim
2, further comprising an electrically conductive surface
3 disposed distally of the aperture, at least a portion of the
4 electrically conductive surface being distally oriented.
- 1 6. A tissue resection device as claimed in claim
2, wherein the electrically conductive area comprises a
3 rounded surface, and wherein at least a portion the

4 electrically conductive surface is within the field of view of
5 the imaging mechanism.

1 7. A tissue resection device comprising:
2 a shaft having a proximal end, a distal end, an
3 aperture adjacent the distal end, and a fluid and tissue
4 aspiration lumen extending from the aperture to the proximal
5 end;
6 a cutting member disposed adjacent to the aperture,
7 the cutting member having a plurality of lobes which
8 simultaneously remove a plurality of tissue strips; and
9 a chopping mechanism disposed within the lumen of
10 the shaft to reduce the size of tissue passing through the
11 lumen.

1 8. A tissue resection device as claimed in claim 1
2 or 7, wherein the cutting member comprises an electrosurgical
3 wire having at least one loop.

1 9. A tissue resection device as claimed in claim
2 7, further comprising an imaging mechanism reciprocable
3 relative to the shaft, wherein the imaging mechanism is
4 oriented distally toward the cutting member.

1 10. A method for resecting tissue from a surgical
2 site of an internal body cavity, the method comprising:
3 cutting strips of tissue from the surgical site by
4 axially translating a cutting member of a probe;
5 aspirating fluid from the surgical site into a
6 radially oriented aperture on a shaft of the probe so that the
7 strips of tissue enter the aperture; and
8 chopping the strips of tissue into tissue fragments
9 as they enter the aperture and evacuating the tissue fragments
10 through the shaft of the probe.

1 11. A method as claimed in claim 10, further
2 comprising flowing irrigation fluid over an imaging mechanism
3 and toward the cutting member while optically imaging the

4 tissue and cutting member through the imaging mechanism, and
5 also while cutting the strips of tissue toward the imaging
6 mechanism.

1 12. A method as claimed in claim 11, wherein the
2 cutting member is translated proximally relative to the
3 imaging mechanism.

13. A method as claimed in claim 11, wherein the
cutting member and imaging mechanism are translated together
by proximally withdrawing the probe.

1 14. A method as claimed in claim 10, further
2 comprising ablating tissue distally of the distal end of the
3 probe with a distally oriented electrically conductive
4 surface.

1 15. A method as claimed in claim 10, wherein the
2 cutting step comprises simultaneously cutting a plurality of
3 strips of tissue.

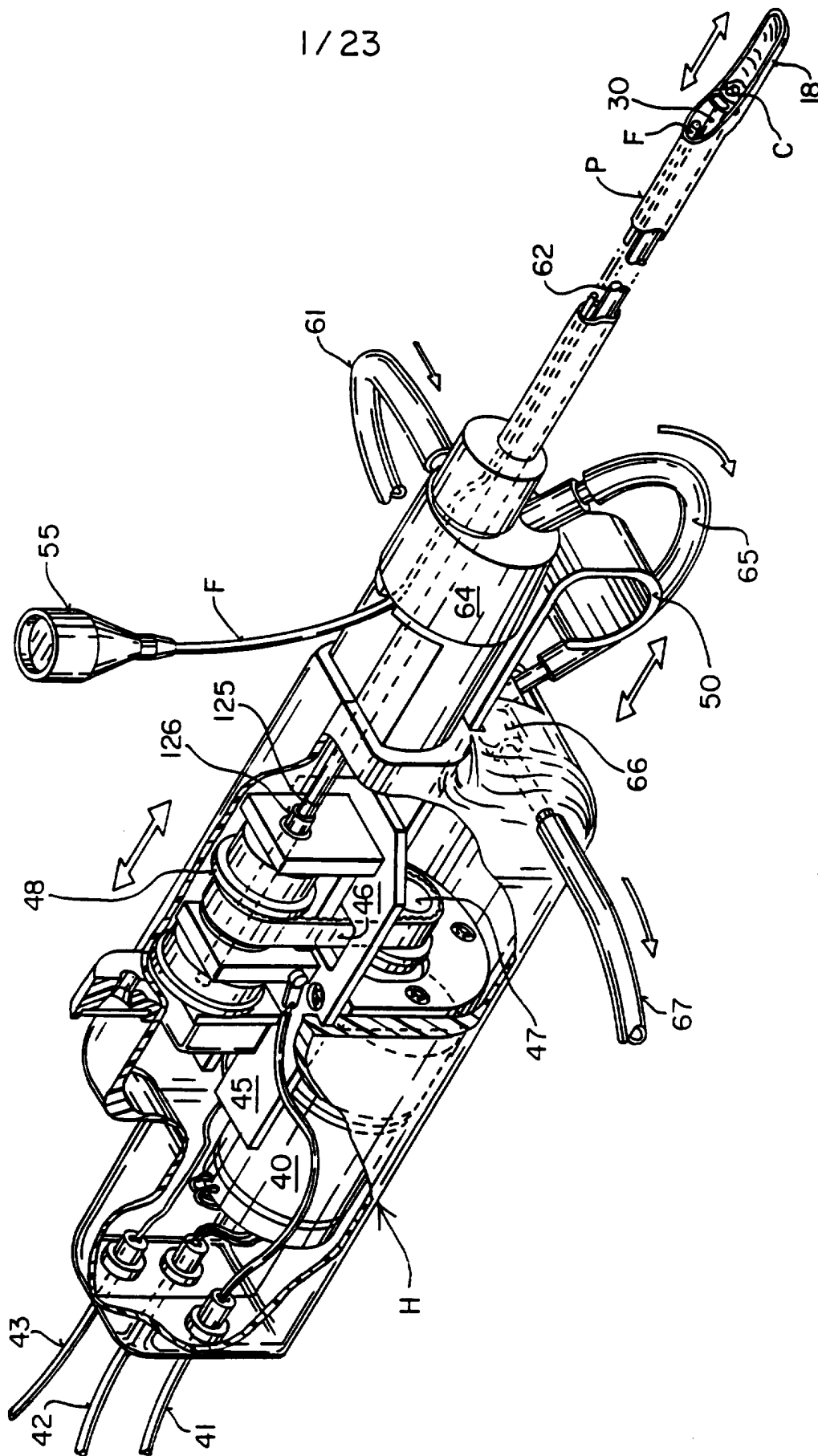

FIG. 1A

2 / 23

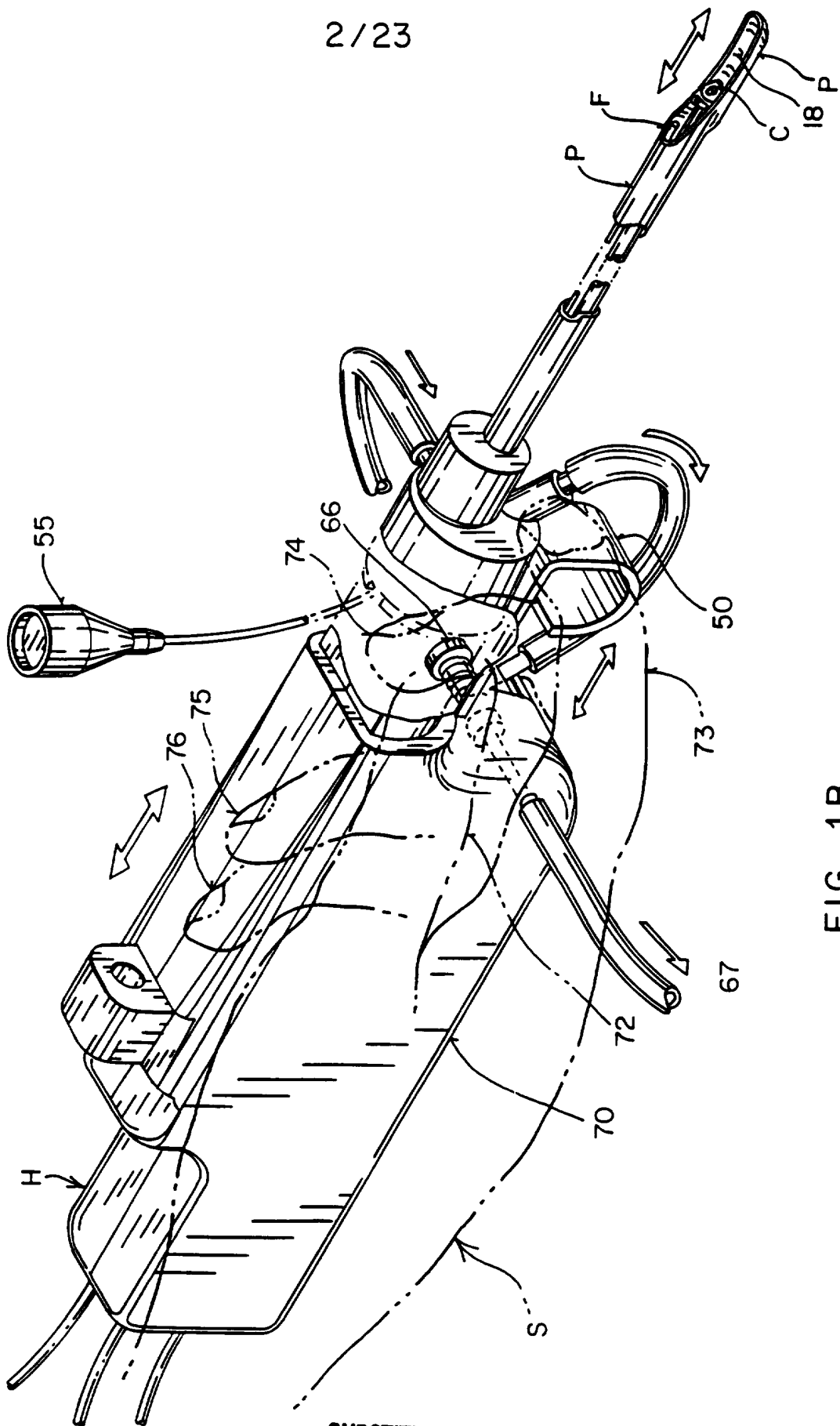

FIG. 1B

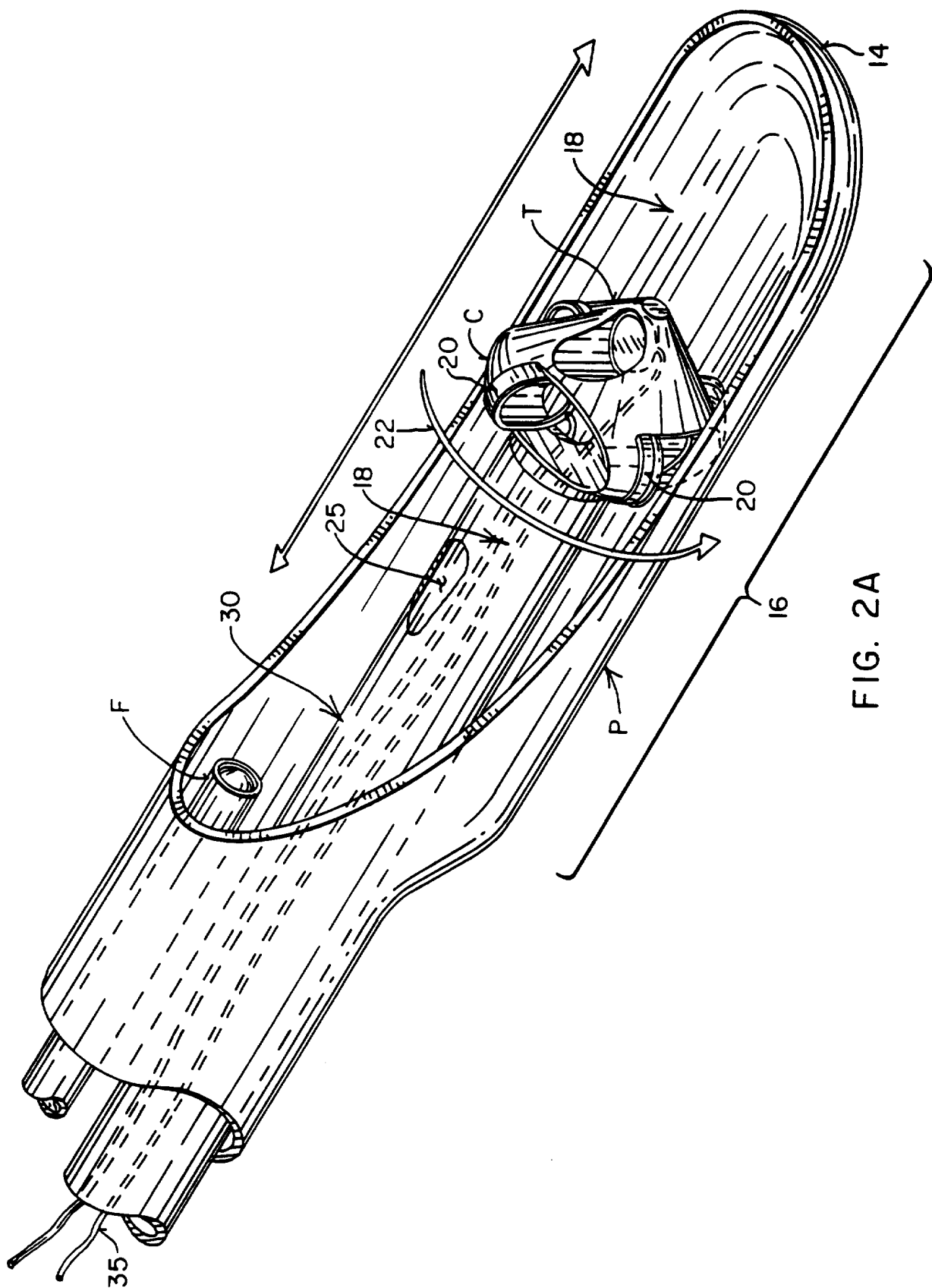

FIG. 2A

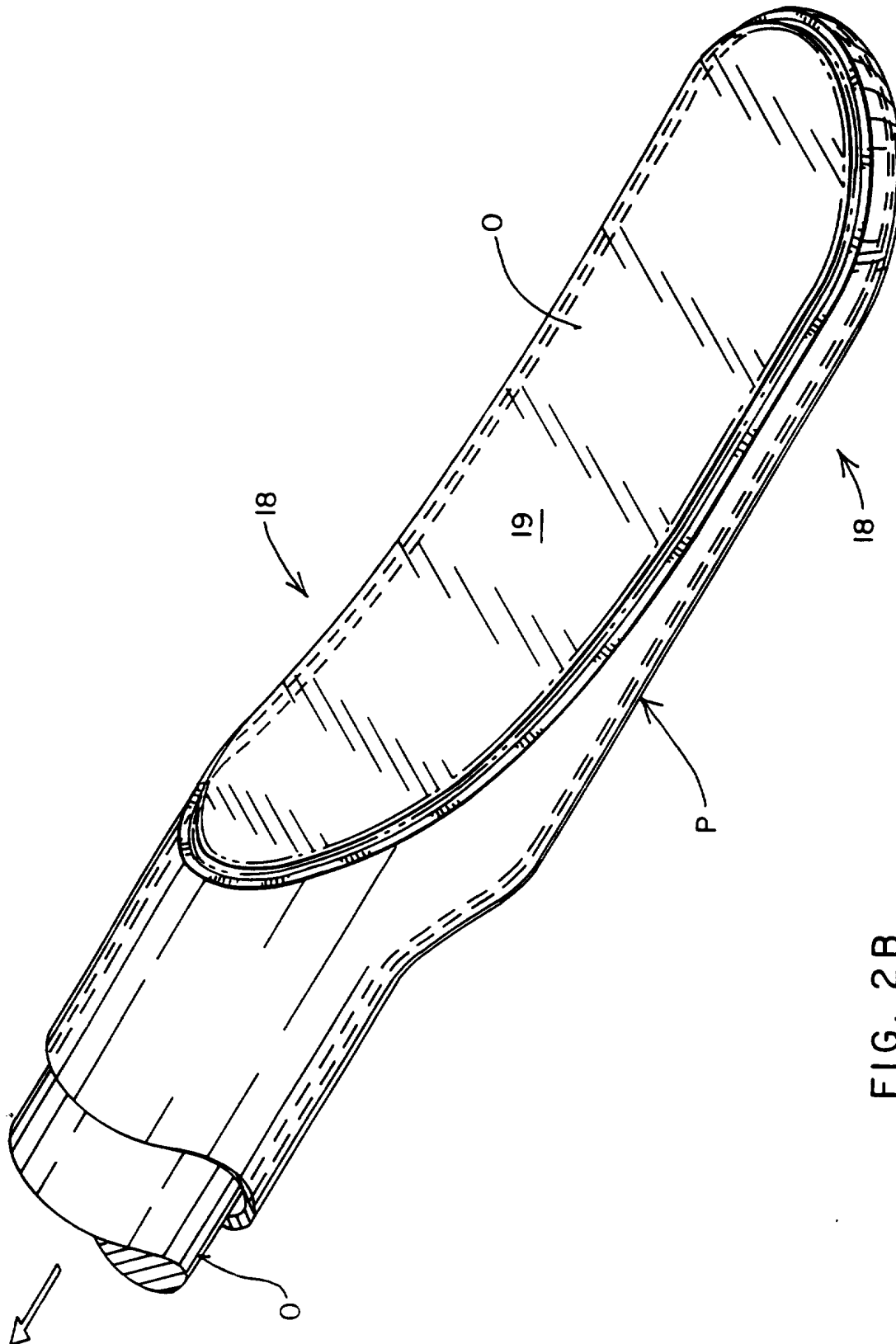

FIG. 2B

5/23

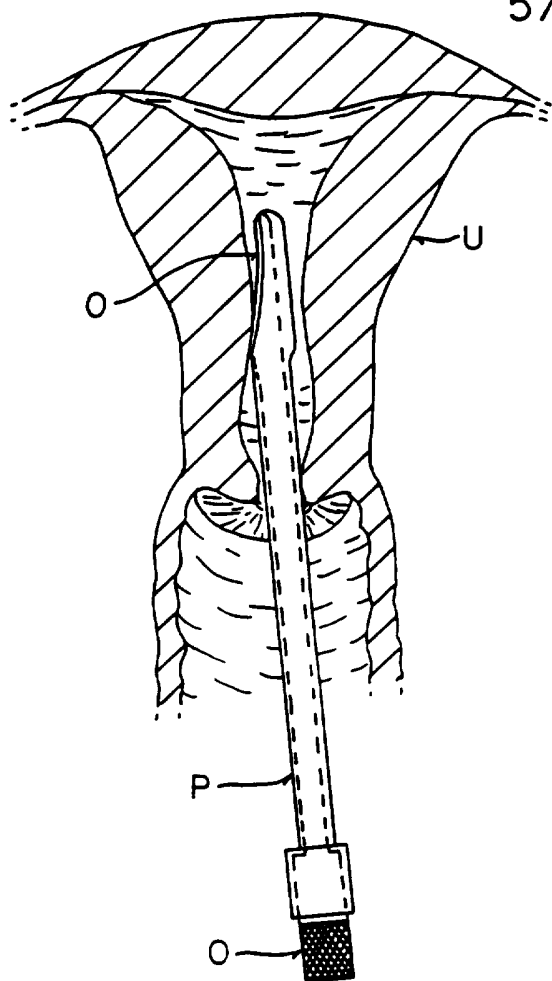

FIG. 3A

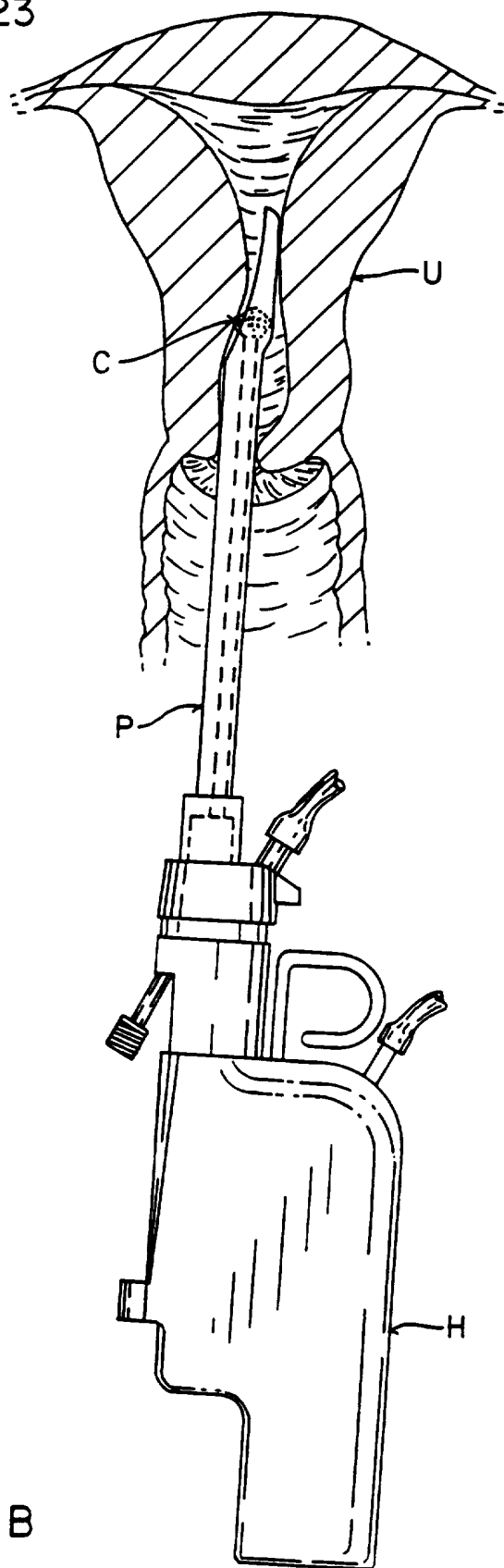

FIG. 3B

6/23

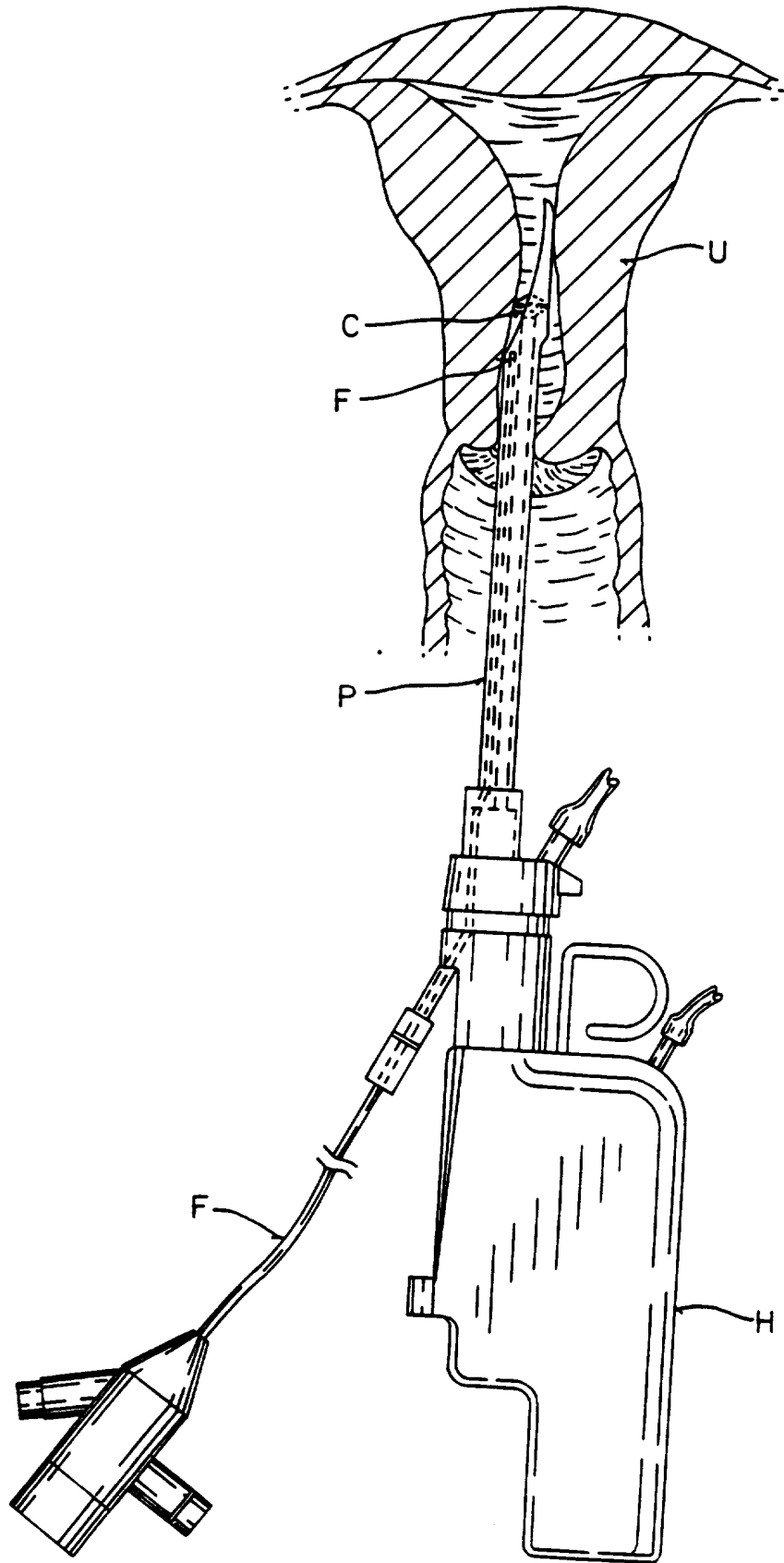

FIG. 3C
SUBSTITUTE SHEET (RULE 26)

7/23

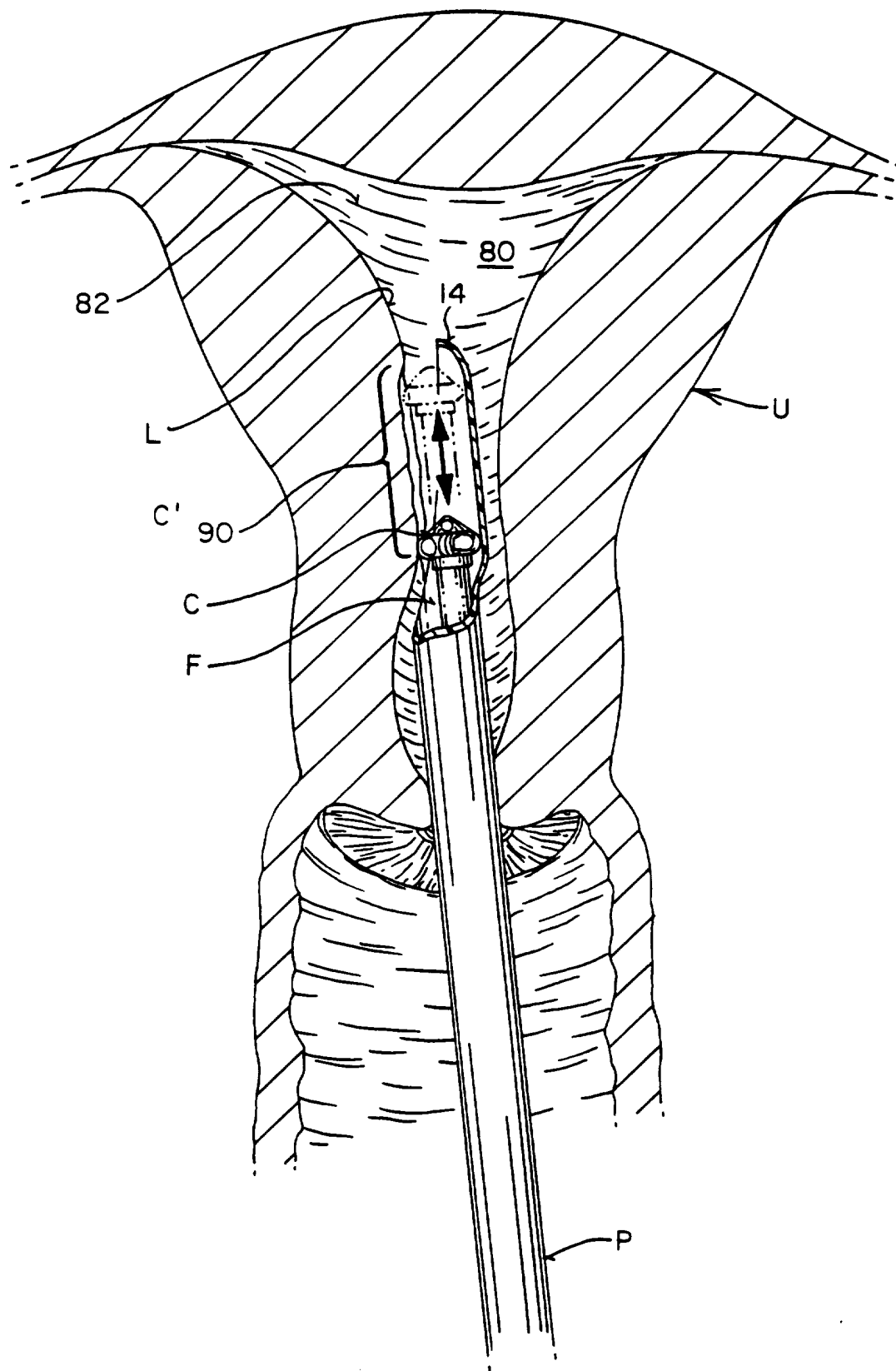

FIG. 4
SUBSTITUTE SHEET (RULE 26)

8/23

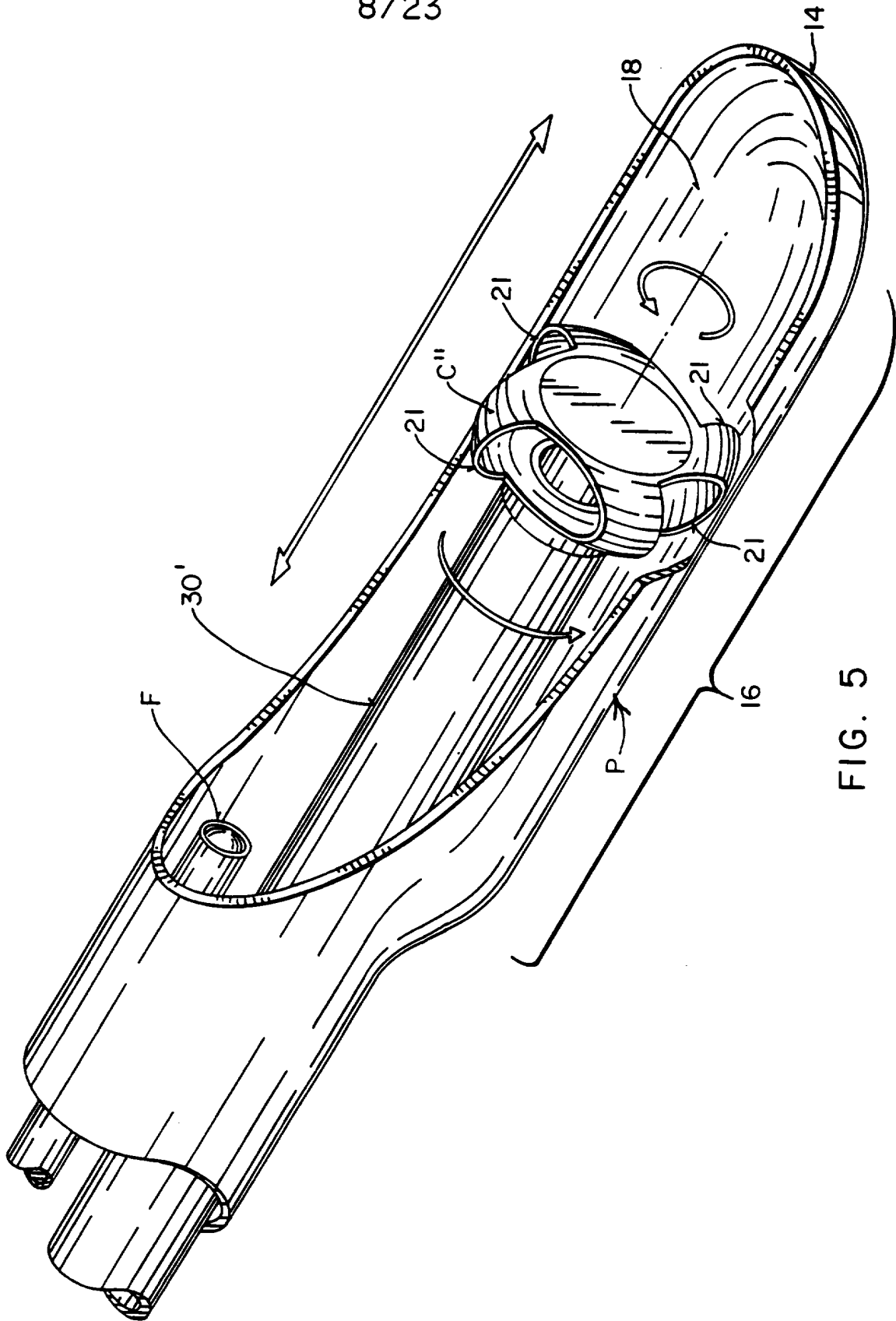
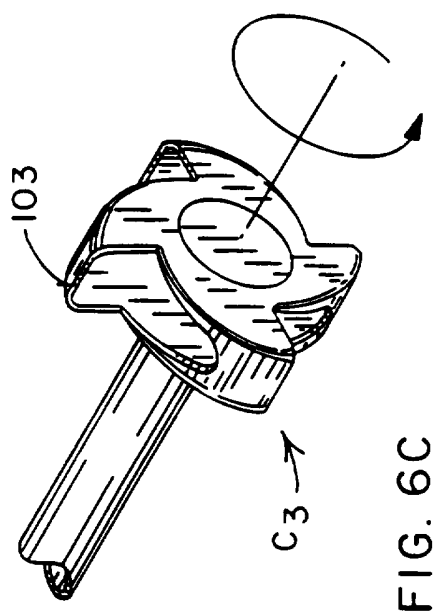
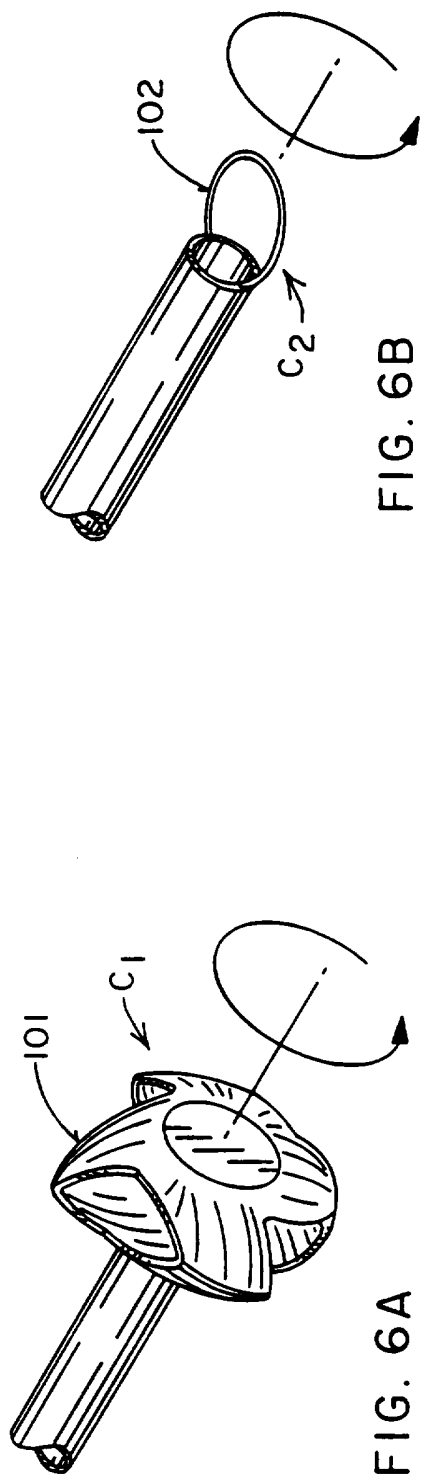
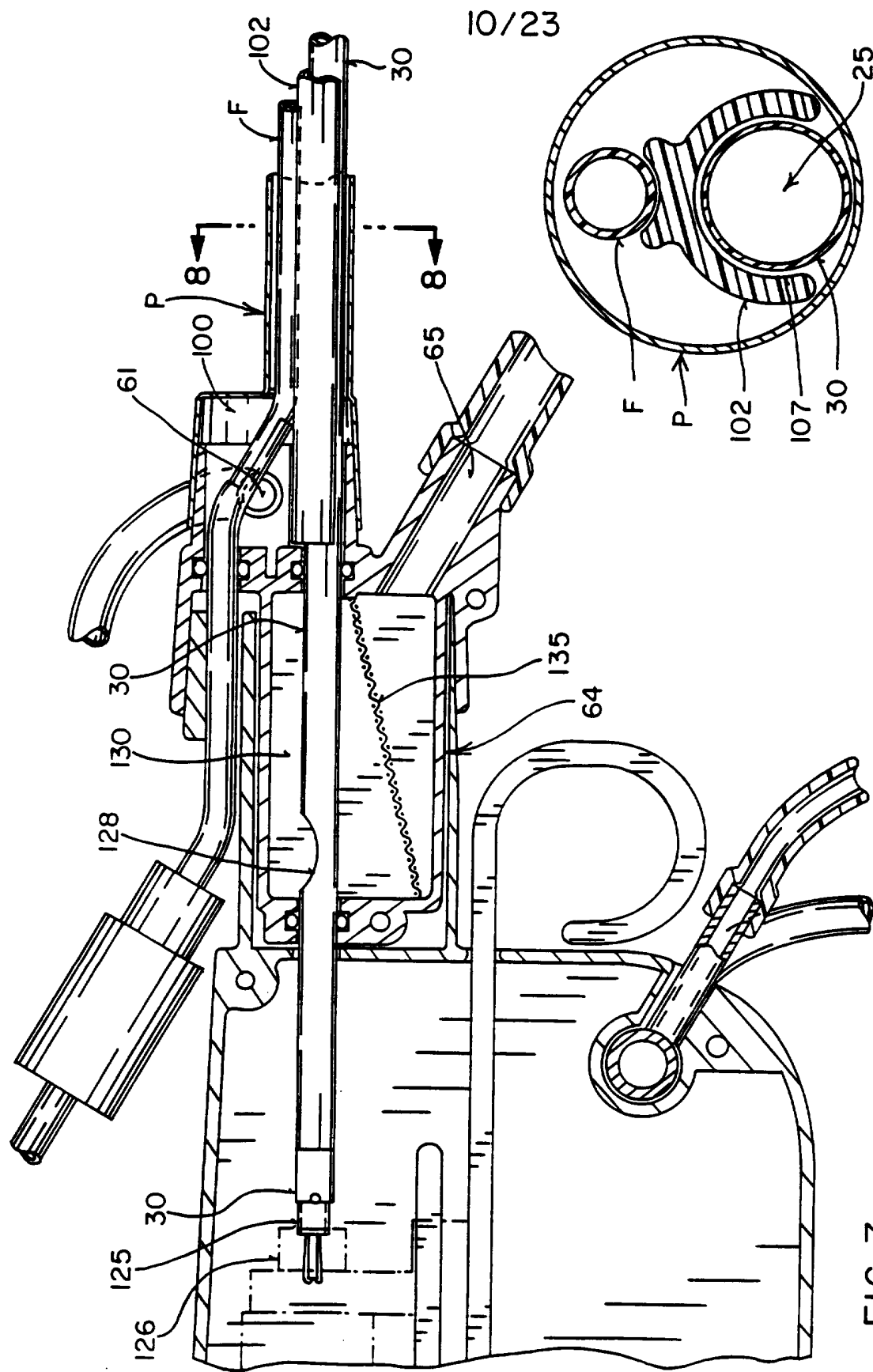

FIG. 5

9/23





10/23

FIG. 8

FIG. 7

11/23

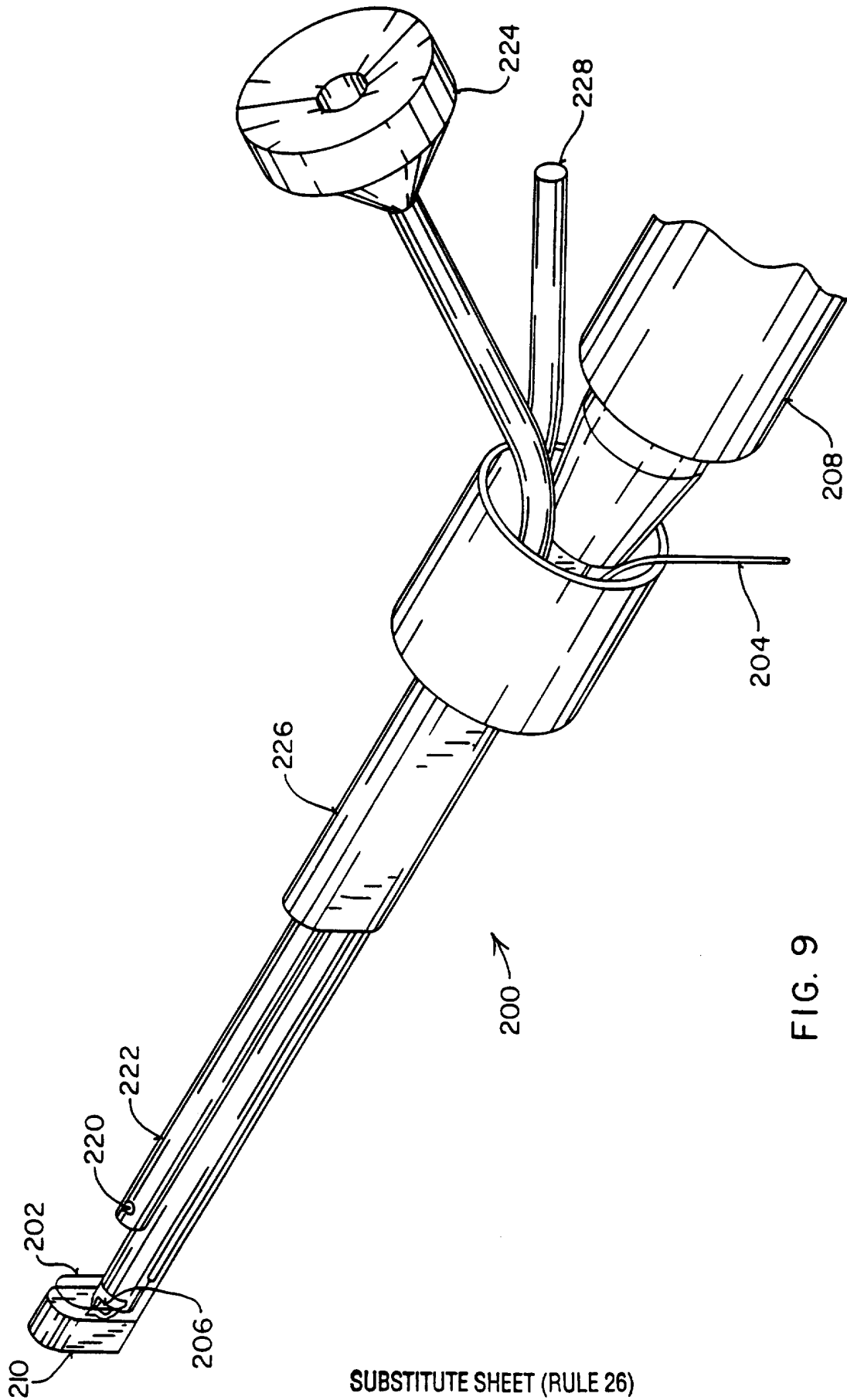

FIG. 9

12/23

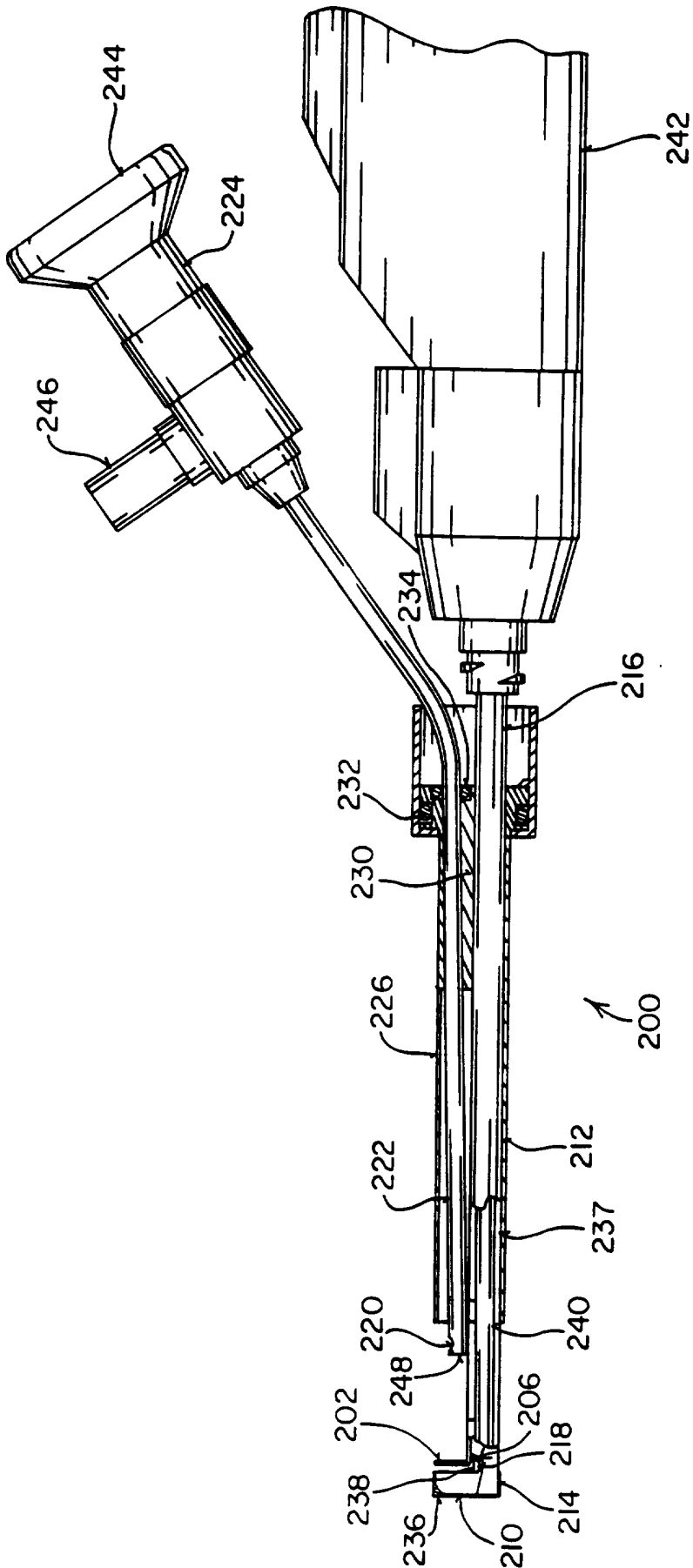

FIG. 10

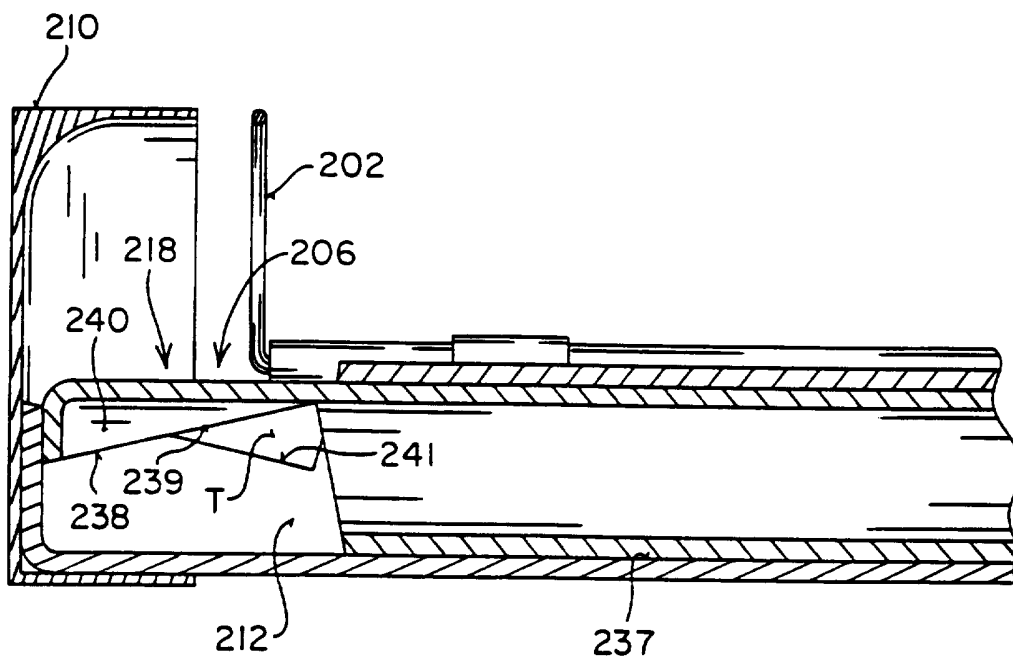

FIG. 10A

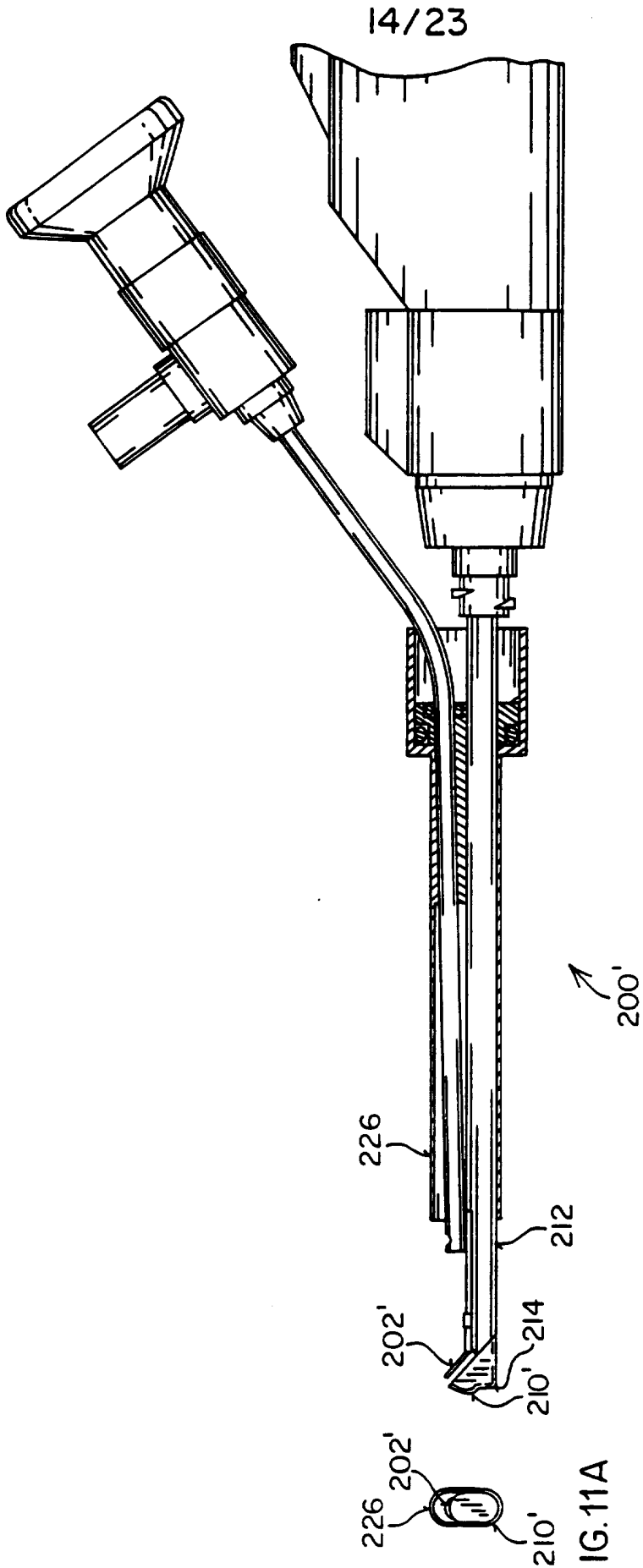

FIG. 11

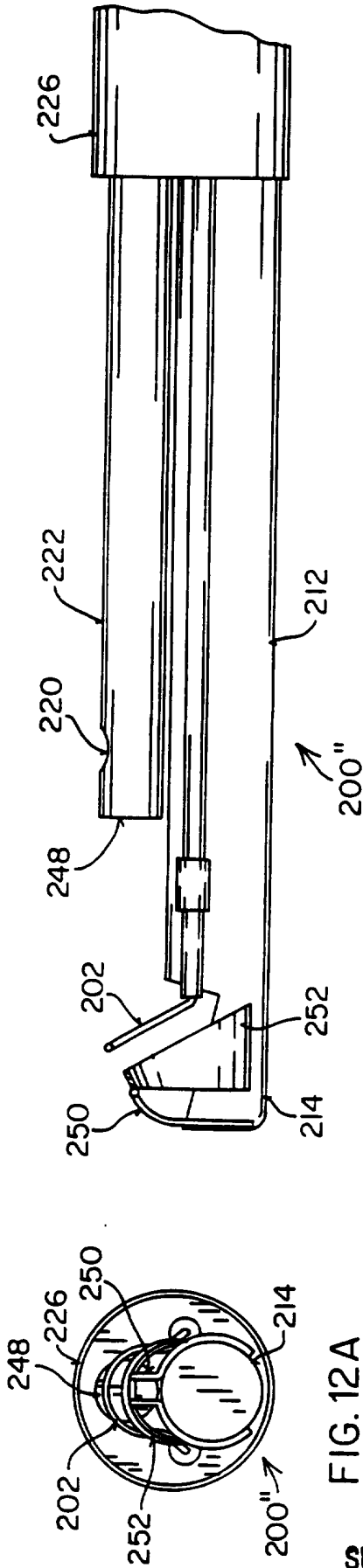

FIG. 12A

FIG. 12

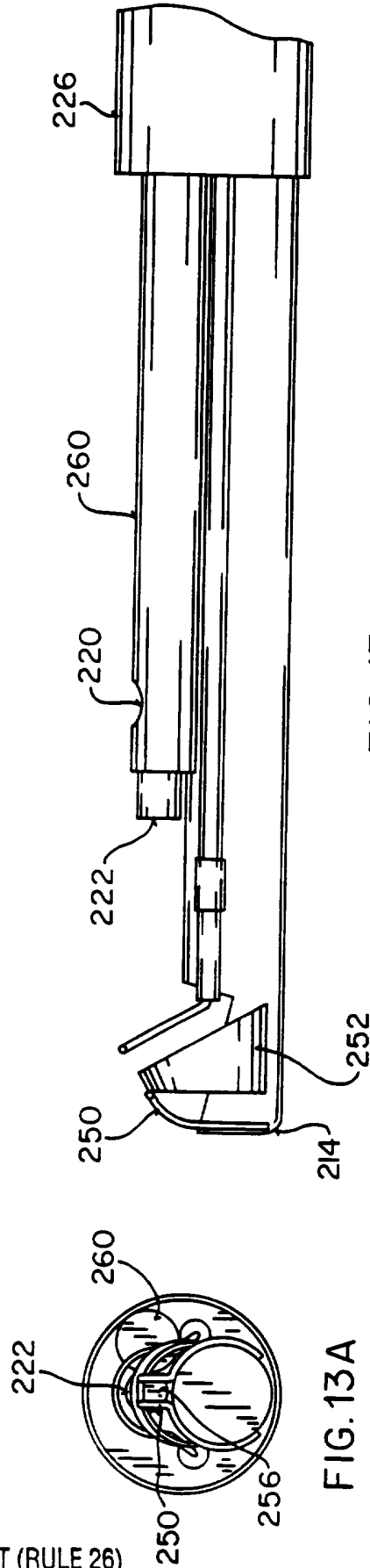

FIG. 13A

FIG. 13

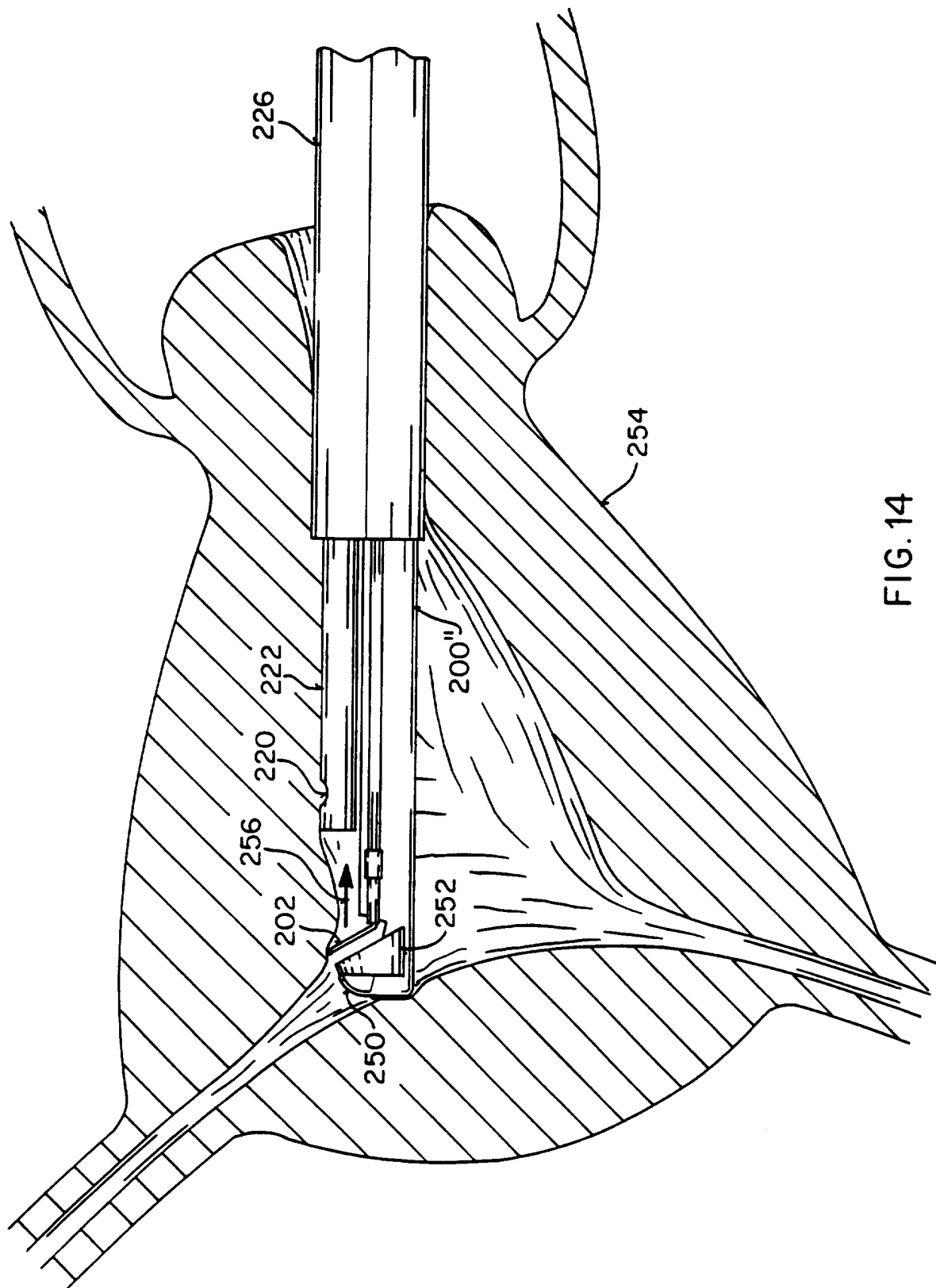

FIG. 14

17/23

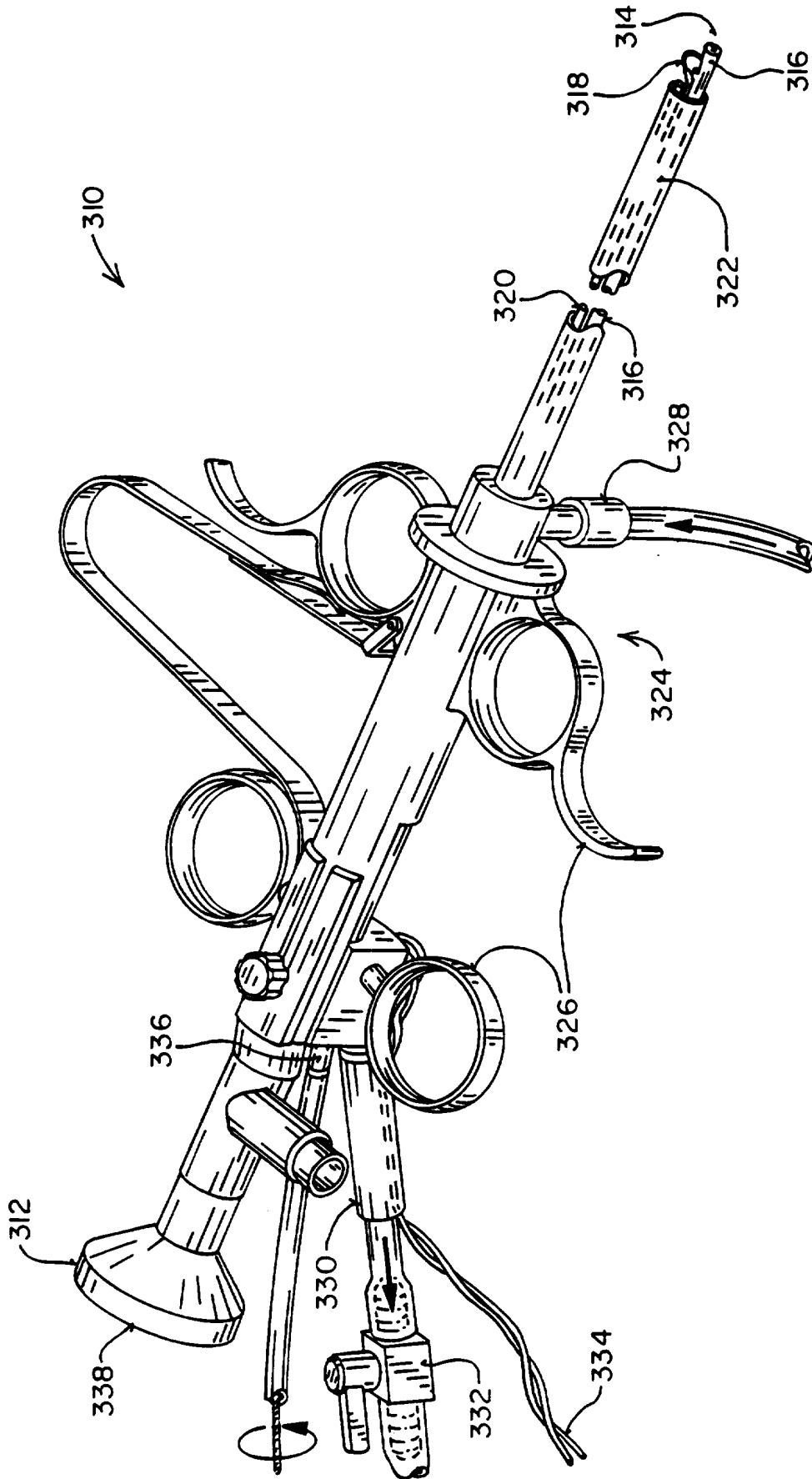

FIG. 15

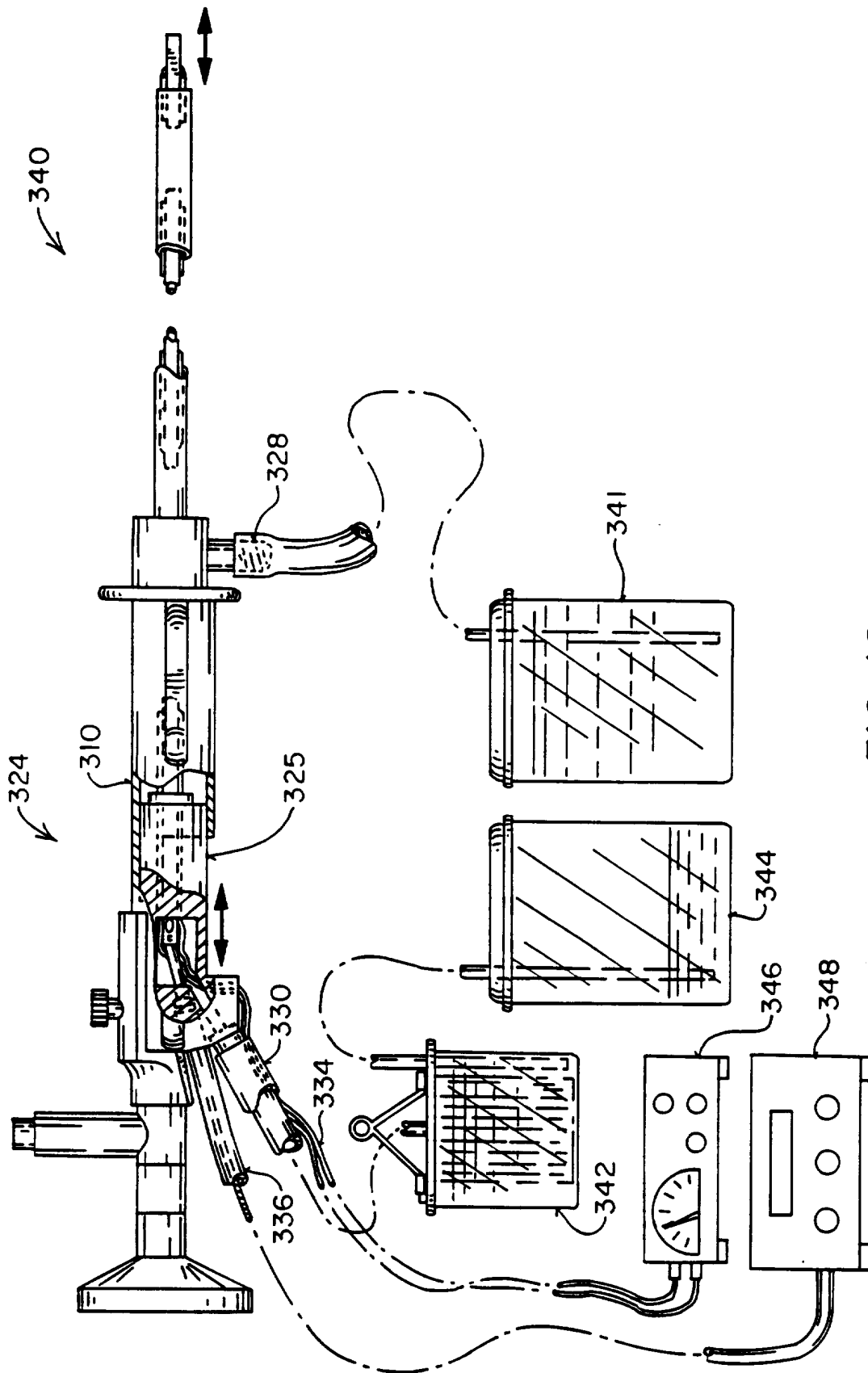

FIG. 16

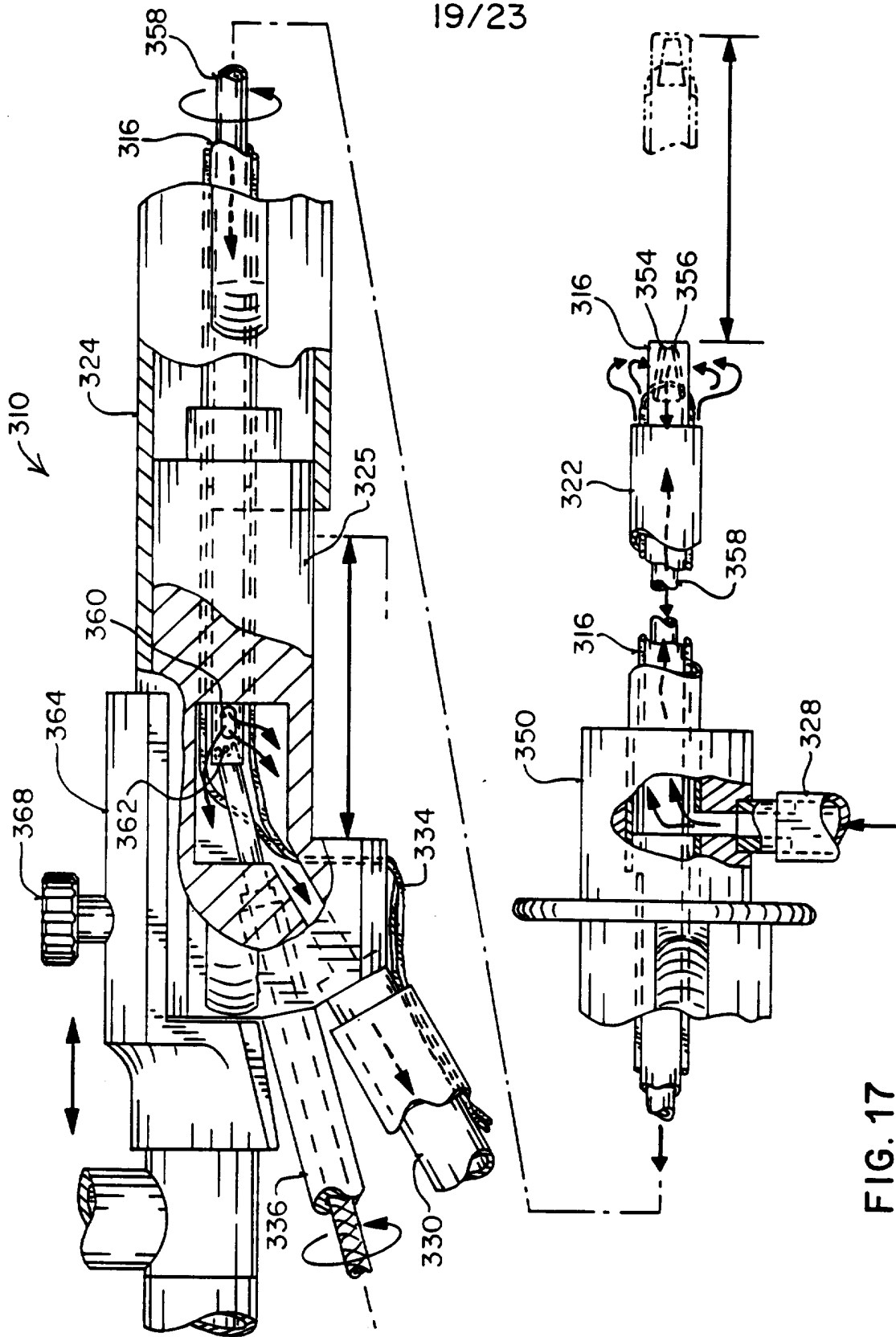

FIG. 17

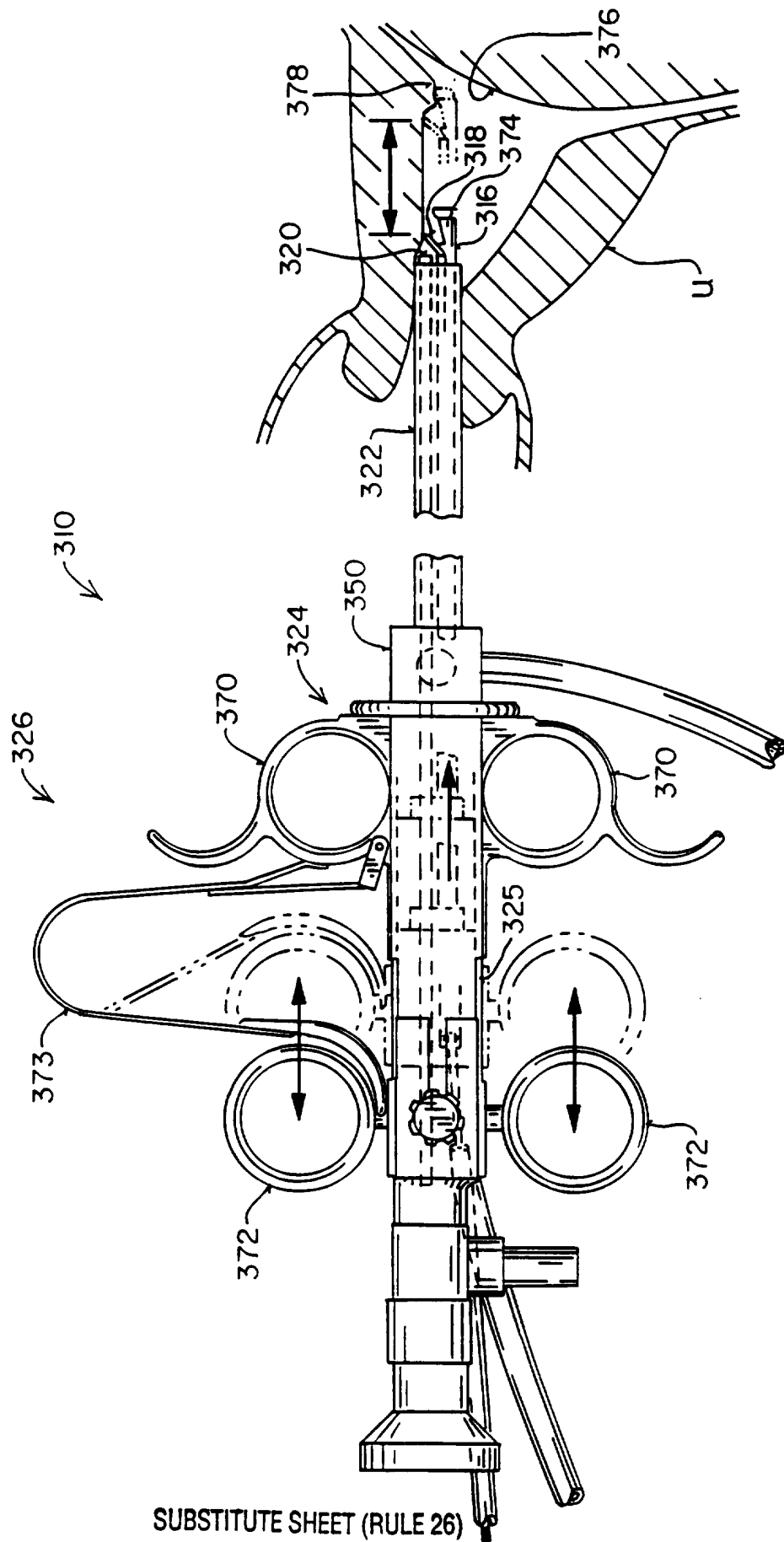

FIG. 18

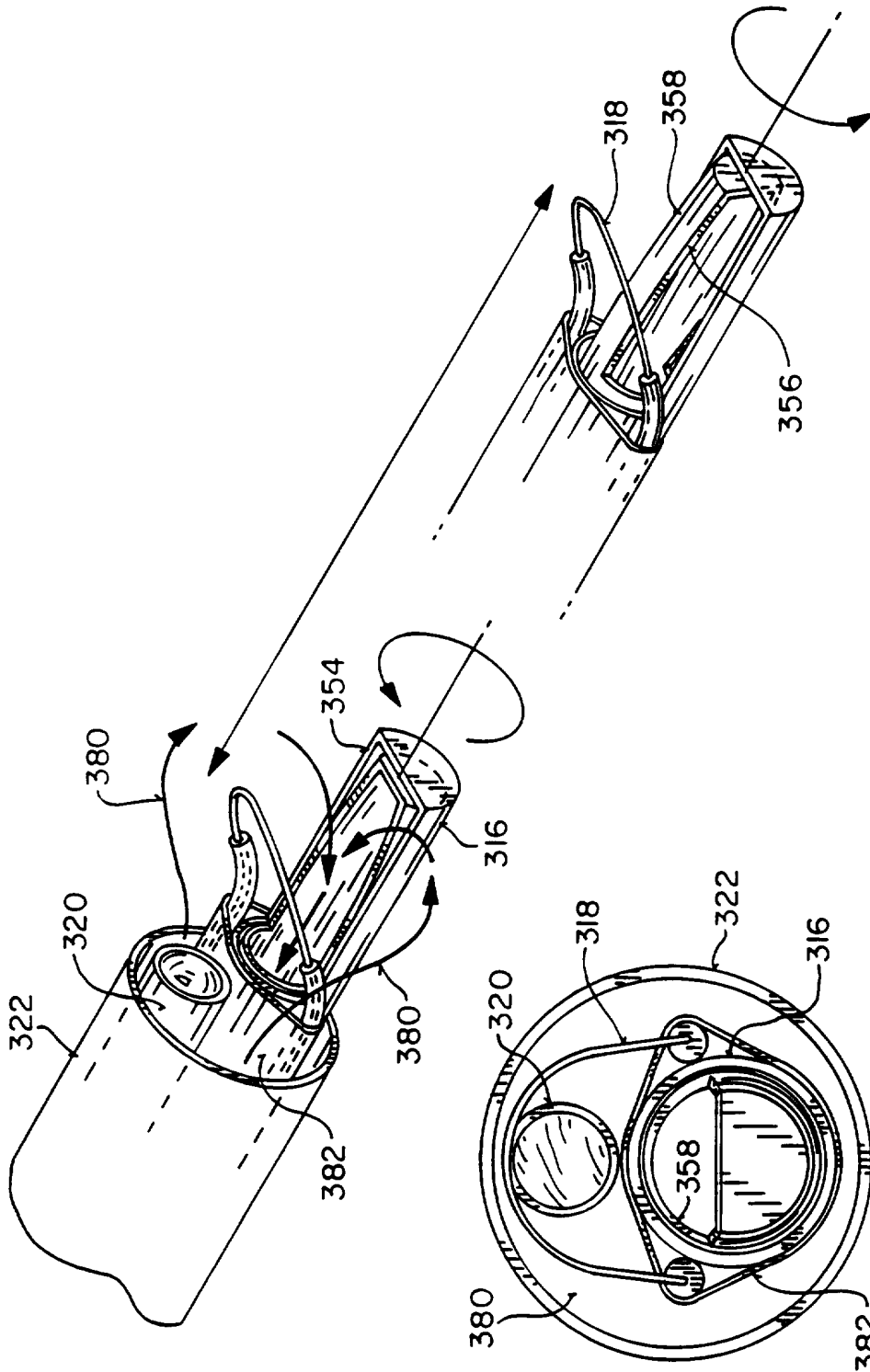

FIG. 19

FIG. 19A



FIG. 21B

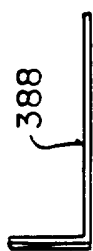

FIG. 21A

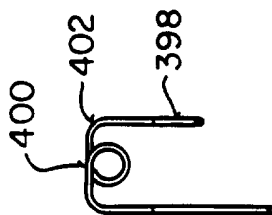

FIG. 23B

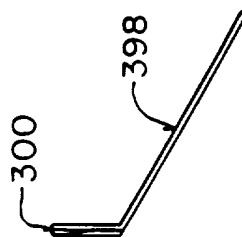

FIG. 23A

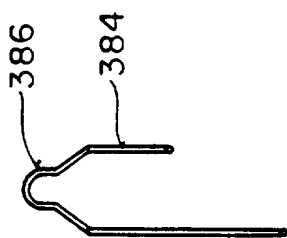

FIG. 20B

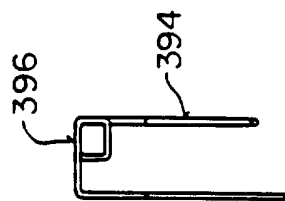

FIG. 22B

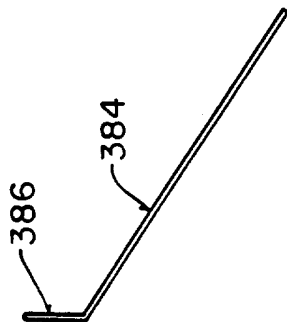

FIG. 20A

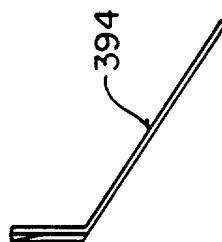

FIG. 22A

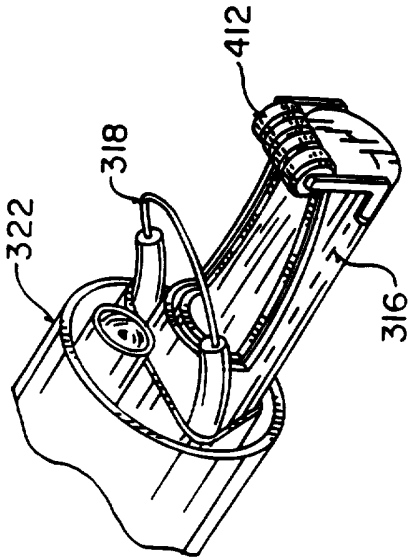

FIG. 25

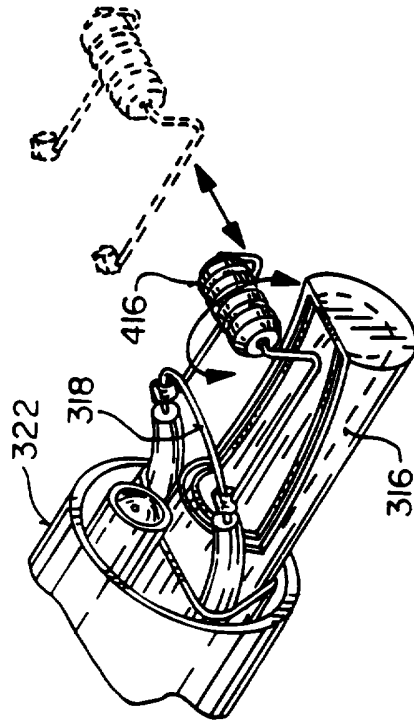

FIG. 27

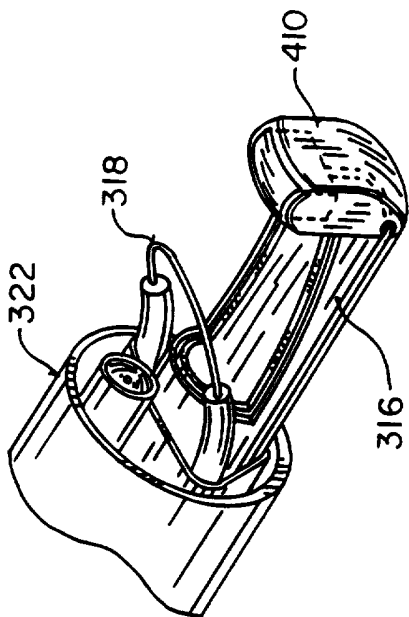

FIG. 24

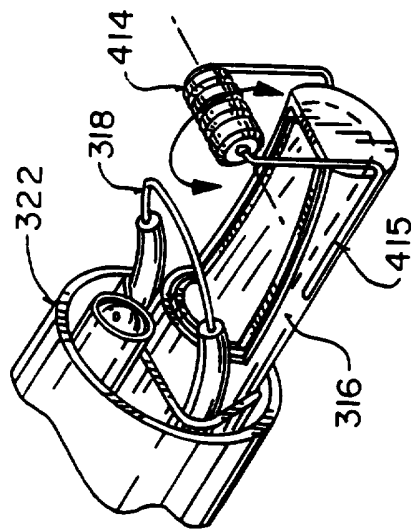

FIG. 26

INTERNATIONAL SEARCH REPORT

International application No.
PCT/US95/13130

A. CLASSIFICATION OF SUBJECT MATTER

IPC(6) :A61B 17/32
US CL :606/41

According to International Patent Classification (IPC) or to both national classification and IPC

B. FIELDS SEARCHED

Minimum documentation searched (classification system followed by classification symbols)

U.S. : 600/104, 105, 160; 604/22; 606/41, 42, 45, 46, 170, 171, 180

Documentation searched other than minimum documentation to the extent that such documents are included in the fields searched
NONE

Electronic data base consulted during the international search (name of data base and, where practicable, search terms used)
NONE

C. DOCUMENTS CONSIDERED TO BE RELEVANT

Category*	Citation of document, with indication, where appropriate, of the relevant passages	Relevant to claim No.
X	US, A, 5,201,731 (HAKKY) 13 April 1993, see whole document.	1-4, 7, 9-13, 15
A, P	US, A, 5,456,689 (KRESCH ET AL.) 10 October 1995, see whole document.	1-15
A, P	US, A, 5,364,395 (WEST, JR.) 15 November 1994, see whole document.	1-15

Further documents are listed in the continuation of Box C. See patent family annex.

* Special categories of cited documents:	"T" later document published after the international filing date or priority date and not in conflict with the application but cited to understand the principle or theory underlying the invention
"A" document defining the general state of the art which is not considered to be part of particular relevance	"X" document of particular relevance; the claimed invention cannot be considered novel or cannot be considered to involve an inventive step when the document is taken alone
"E" earlier document published on or after the international filing date	"Y" document of particular relevance; the claimed invention cannot be considered to involve an inventive step when the document is combined with one or more other such documents, such combination being obvious to a person skilled in the art
"L" document which may throw doubts on priority claim(s) or which is cited to establish the publication date of another citation or other special reason (as specified)	"&" document member of the same patent family
"O" document referring to an oral disclosure, use, exhibition or other means	
"P" document published prior to the international filing date but later than the priority date claimed	

Date of the actual completion of the international search
08 FEBRUARY 1996

Date of mailing of the international search report
06 MAR 1996

Name and mailing address of the ISA/US
Commissioner of Patents and Trademarks
Box PCT
Washington, D.C. 20231

Authorized officer *Michael Peffley*
MICHAEL PEFFLEY

Facsimile No. (703) 305-3230

Telephone No. (703) 308-4305