

(19) World Intellectual Property Organization  
International Bureau



(43) International Publication Date  
15 February 2001 (15.02.2001)

PCT

(10) International Publication Number  
**WO 01/11721 A1**

(51) International Patent Classification<sup>7</sup>: **H01Q 5/00**

(21) International Application Number: PCT/SE00/01543

(22) International Filing Date: 4 August 2000 (04.08.2000)

(25) Filing Language: English

(26) Publication Language: English

(30) Priority Data:  
9902878-9 11 August 1999 (11.08.1999) SE

(71) Applicant (for all designated States except US): **ALLGON AB** [SE/SE]; Antennvägen 6, S-187 80 Täby (SE).

(72) Inventor; and

(75) Inventor/Applicant (for US only): **RUTFORS, Tomas** [SE/SE]; Störängsvägen 16, S-184 31 Åkersberga (SE).

(74) Agent: **EHRNER & DELMAR PATENTBYRÅ AB**; Box 103 16, Gumshornsgatan 7, S-100 55 Stockholm (SE).

(81) Designated States (*national*): AE, AG, AL, AM, AT, AT (utility model), AU, AZ, BA, BB, BG, BR, BY, BZ, CA, CH, CN, CR, CU, CZ, CZ (utility model), DE, DE (utility model), DK, DK (utility model), DM, DZ, EE, EE (utility model), ES, FI, FI (utility model), GB, GD, GE, GH, GM, HR, HU, ID, IL, IN, IS, JP, KE, KG, KP, KR, KR (utility model), KZ, LC, LK, LR, LS, LT, LU, LV, MA, MD, MG, MK, MN, MW, MX, MZ, NO, NZ, PL, PT, RO, RU, SD, SE, SG, SI, SK, SK (utility model), SL, TJ, TM, TR, TT, TZ, UA, UG, US, UZ, VN, YU, ZA, ZW.

(84) Designated States (*regional*): ARIPO patent (GH, GM, KE, LS, MW, MZ, SD, SL, SZ, TZ, UG, ZW), Eurasian patent (AM, AZ, BY, KG, KZ, MD, RU, TJ, TM), European patent (AT, BE, CH, CY, DE, DK, ES, FI, FR, GB, GR, IE, IT, LU, MC, NL, PT, SE), OAPI patent (BF, BJ, CF, CG, CI, CM, GA, GN, GW, ML, MR, NE, SN, TD, TG).

Published:

— With international search report.

For two-letter codes and other abbreviations, refer to the "Guidance Notes on Codes and Abbreviations" appearing at the beginning of each regular issue of the PCT Gazette.

(54) Title: SMALL SIZED MULTIPLE BAND ANTENNA

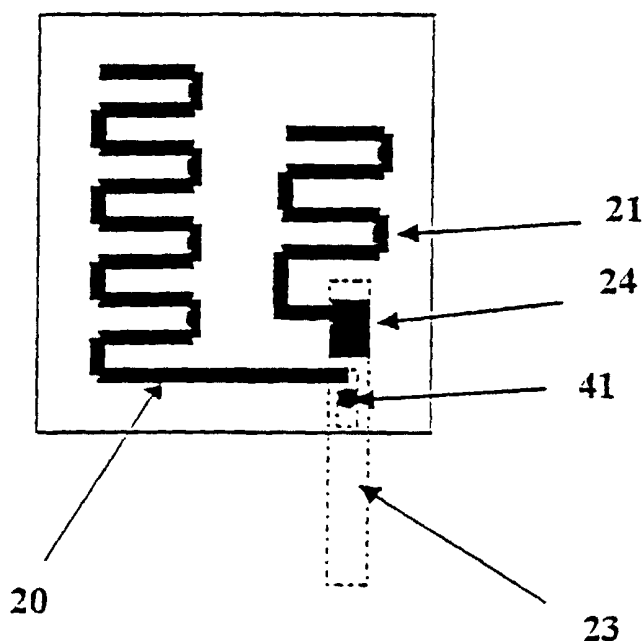

(57) Abstract: A multiple frequency band antenna, comprising at least two antenna elements (10, 11, 20, 21, 60) connected via an antenna feeding network to a radio frequency source/receiver, said antenna elements being operable in at least two non-overlapping frequency bands. The antenna feeding network comprises means for connection to the radio frequency source/receiver, means for direct electrical connection to a feed-end portion of a first antenna element (10, 20) being operable in a lowermost frequency band, and means for capacitive coupling (24, 90) to a feed-end portion of at least a second antenna element being operable in a frequency band which is higher than said lowermost frequency band. Further, the capacitive coupling being dimensioned to provide a relatively high impedance for frequencies in said lowermost frequency band and a relatively low impedance for frequencies in said higher frequency band.

WO 01/11721 A1

## SMALL SIZED MULTIPLE BAND ANTENNA

The present invention relates to a multiple frequency band antenna according to the introductory portion of claim 1.

5 Specifically, the invention concerns a multiple frequency band antenna with a feeding network, which requires one of the antenna elements to be connected to the radio frequency source/receiver via a capacitive element.

10 A general problem when two antenna radiators being situated in close proximity to each other is the strong inter-coupling between them, and this problem is enhanced further when the radiators are directly electrically connected to each other. This inter-coupling reduces the efficiency and the bandwidth  
15 of the antenna elements. As a reduction of the size of an antenna element only, gives rise to a reduction of the relative bandwidth, the problem for a multiple band antenna, constituted by small antenna elements situated in close proximity to each other, is severe. Providing each antenna  
20 element with separate external circuitry for connection the radio frequency source/receiver is a possible solution, but adds further components to the system and the need for separate handling of these, which adds to the cost of the multiple band antenna. A method for integrating a feeding  
25 network, including a capacitive element connecting the antenna element operable at the higher frequency band with the radio frequency source/receiver, with the antenna elements without need for any additional components or steps in the manufacturing process has been lacking.

30

Capacitive or inductive coupling between antenna elements in a multiple band antenna has been described in several patent

documents, a recent example of which is WO 99/26314 (Moteco  
AB, P.O. Box 910, S-391 29 Kalmar, Sweden). This document  
discloses a dual-band antenna with two fixed antenna elements  
for the stand-by position, and two extendable antenna elements  
5 for the talk positions. Each of the antenna elements for the  
stand-by position, and each of the antenna elements for the  
talk positions, are capacitively/inductively coupled to each  
other, respectively. This coupling is realised by partially or  
fully overlapping of the larger diameter antenna element  
10 around the smaller diameter antenna element. The coupling  
takes place along the antenna elements, or a portion thereof,  
and the capacitive coupling cannot be dimensioned separately  
as an independent parameter, but changing the extent of  
capacitive coupling by changing the extent of overlap between  
15 the antenna elements, or changing the design of the antenna  
elements, will also affect the radio frequency properties of  
the antenna elements.

WO 98/49747 (Galtronics Ltd, P.O. Box 1589, 14115 Tiberias,  
20 Israel) discloses a dual-band antenna constituting two antenna  
elements, the two antenna elements being operable at two  
distinct frequencies. The two antenna elements are in each of  
the embodiments described as linear antenna elements, either  
rod-shaped or helix shaped, and the two antenna elements are  
25 situated in line with each other, one on top of the other. The  
two antenna elements are capacitively coupled to each other,  
and in each of the embodiments described this is achieved by  
positioning the top end of the lower element in close  
proximity with the lower end of the upper element, or by  
30 partially overlapping the upper portion of the lower element  
with the lower portion of the upper element. The method is  
suitable when the height of the dual-band antenna is not of

great importance, and it is therefore not well suited for small sized antenna means.

5 An object of the invention is to provide a feeding network for multiple band antennas that avoids the problems related to coupling between the individual antenna elements that are directly electrically connected to each other. Further objects are to provide a feeding network which provides for coupling to the radio frequency source/receiver, and which may be  
10 integrated with the antenna, and which may therefore be manufactured without any manufacturing steps in addition to those needed for producing the antenna elements and the structure supporting these, thus giving a feeding network that is low cost and rigid.

15

These and other objects are attained by an antenna means with a feeding network according to the characterising portion of claim 1. The feeding network avoids the problems that occur when the antenna elements are directly electrically connected  
20 to each other by providing capacitive coupling to the second antenna element, and by choosing the capacitance of the capacitive element such that, at the frequency at which the lowest band element is operable, the impedance of the capacitance is high. This effectively decouples the higher  
25 band element from the lower band element, thus reducing problems occurring as a result of the coupling between the elements. This simplifies the construction of an antenna with two small antenna elements being situated in close proximity to each other, where the problem of coupling between the  
30 elements due to electromagnetic effects is already present. The feeding network is of course also advantageous when the elements are not small and closely spaced, although the feeding network is particularly advantageous for small

antennas such that, at the frequency at which the lowest band element is operable, the impedance of the capacitive coupling is high. Accordingly, it has turned out that coupling the second antenna element capacitively to the feeding network, as described by the present invention, increases the bandwidth of the lower frequency band, and it may also increase the overall efficiency of the multiple band antenna.

When dimensioning the capacitance of the capacitive element, the aspect of impedance matching to the radio frequency source/receiver may also be taken into consideration. This gives an additional degree of freedom when designing a multiple band antenna element. If the feeding network including the capacitive element is manufactured as an integral part of the antenna means, this may reduce the number of additional components needed in the radio frequency source/receiver for impedance matching, while still keeping the manufacturing cost for the feeding network low.

Extending the feeding network to an embodiment with more than two antenna elements needs careful dimensioning of the capacitive elements of the feeding network. When operating the antenna at a certain frequency, at which a particular antenna element is operable, the impedance of the capacitors connecting all higher frequency antenna elements to the feeding network, should be so high that it effectively disconnects them from the feeding network. The ratio of the capacitances of two capacitive elements connecting two antenna elements operable at two consecutive frequencies, should preferably be of the order of one to ten. Of course, the optimal ratio for a particular design of an antenna varies from case to case.

The feeding network also provides for electrical connection to the radio frequency source/receiver via a feed end portion of the particular antenna element. The feeding network is designed for an optimal electrical connection to the radio frequency source/receiver , for optimal radio frequency properties, which may include taking impedance matching to the radio frequency source/receiver into consideration, and mechanical durability and rigidity. If the feeding portion of the feeding network, and the rest of the feeding network, can be manufactured as an integral part of the antenna means, this is an additional advantage.

## BRIEF DESCRIPTION OF THE DRAWINGS

15

Fig. 1 is a side view of an antenna according to a first embodiment of the invention, with two helix antenna elements and a feeding network;

20 Fig. 2 is a planar view of a second element of the antenna with two meander antenna elements, and a feeding network;

Fig. 3 is a planar view of a third embodiment, likewise with two meander antenna elements and a feeding network;

25

Fig. 4 is a side view of the antenna elements and the feeding network illustrated in fig. 3;

30 Fig. 5 is a planar view of a fourth embodiment, with first and second antenna elements situated on both sides of a substrate;

Fig. 6 is a planar view of a fifth embodiment with a multi-layer substrate and three meander antenna elements;

Fig. 7 shows a sixth embodiment with two antenna elements;

5

Fig. 8 shows the embodiment of fig. 7 from above, in its folded condition;

Fig. 9 shows a seventh embodiment with two antenna elements, where the capacitive coupling is realised with a discrete capacitor.

10

## DESCRIPTION OF PREFERRED EMBODIMENTS

15

The first embodiment shown in figure 1 includes two helix antenna elements 10, 11 nested inside each other, where the feeding network is constituted by the coil necks 12, 13 of the two elements. The smaller diameter coil neck 13 is situated inside the larger coil neck 12, and the two coil necks 12, 13 are mechanically fixed with respect to each other by means of a dielectric substance 14, which also provides capacitive coupling between the two coil necks 12, 13, situated in the volume between the two coil necks 12, 13. The outer coil neck 12 is directly electrically connected to the radio frequency source/receiver.

20

25

The second embodiment (fig. 2) comprises two meander antenna elements 20, 21 situated on an upper surface of a substrate. The feeding network is provided with a means in the form of a tongue or a spring 23 for electrical connection to the radio frequency source/receiver, and the capacitive element 24 used

30

for capacitive coupling to the second antenna element, is situated on the same surface as the antenna elements 20, 21. In this case, the capacitive coupling means 24 of the feeding network is provided by two portions of the feeding network which extend in parallel to each other at a close mutual distance.

In the third embodiment, shown in fig. 3, first 20 and second meander antenna elements 21 are likewise situated on the upper surface of a substrate, while the feeding network has portions situated on both the upper and the lower surface and has means for capacitive coupling 24 through the substrate to a feed end portion of the second antenna element, means for direct electrical connection to a feed end portion of the first antenna element, and means for electrical connection to the radio frequency source/receiver. The upper and the lower portions of the feeding network are electrically connected with a conducting portion 41 extending through the substrate.

Fig. 4 is a side view of the third embodiment illustrated in fig. 3, where the second antenna element 21, connected to the means for capacitive coupling 24 to the feeding network through the substrate 40, is shown on the upper side of the substrate 40. Only the feed-end of the first antenna element 20 is shown in this figure. Also shown is a conductive portion 41 of the feeding network extending through the substrate.

Fig. 5 shows a fourth embodiment with the first meander antenna element 20 situated on the upper surface of a substrate, and the second antenna element 21 situated on the lower side. The feeding network extends on both sides of the substrate, and an upper conductive layer portion of the feeding network and a lower conductive layer portion of the



feeding network are electrically connected to each other via a capacitive element 24. The upper conductive layer portion of the feeding network also comprises a feed-end portion 50.

5 Fig. 6 shows a fifth embodiment with a multi-layer substrate having three meander antenna elements 20, 60, 21 situated on the upper surface of an upper substrate, between the upper and lower substrates, and on the lower surface of the lower substrate, respectively. As shown in the figure, the size of  
10 the capacitive elements 61, 62, and the corresponding values of the capacitances, differs between the two antenna elements 60, 21 being capacitively coupled to the feeding network. The ratio of the capacitances can thus be set by selecting the size of each capacitive element 61, 62, and these capacitances  
15 should preferably be set such that only one of the elements at a time is strongly coupled to the source. As a rough estimate, a ratio of 1:10 would suffice, but this ratio, and the absolute values of the capacitances, may vary depending on the actual design of the multi-band antenna element. It should be  
20 set such that, at the frequency at which the lowest band element 20 is operable, the impedance of both the capacitances is high. At the frequency, at which the middle band element 60 is operable, the impedance of the capacitive element, coupling the element 21 operable at the highest frequency, is high.

25 Fig. 7 shows a sixth embodiment with two antenna elements 20, 21 located on one side of a flexible substrate, intended for achieving a capacitive coupling from the feeding network through the substrate to the second antenna element by folding  
30 the substrate such that the substrate extends circumferentially more than one full turn and the two extended conductive areas 24 are positioned on top of each other, with one layer of the substrate situated there between. The antenna

element, which is preferably flat during the initial manufacturing process, may be folded around a suitable frame 80 (shown in fig. 8) in a second processing step, or it may be folded using some other method that guarantees a high  
5 precision in the positioning of the two conductive areas 24 with respect to each other. A particular advantage of this embodiment is that only one conductive layer is needed for the meander antenna elements and the feeding network, and no additional components or steps in the manufacturing process  
10 are needed. Still, upon completion, the antenna has a small size. Fig. 8 shows the embodiment of fig. 7 from above, in its folded condition.

The seventh embodiment, shown in fig. 9, comprises two meander  
15 antenna elements 20, 21 situated on an upper surface of a substrate, as in the second embodiment. The capacitive element, realized in the above embodiments as an integral part of the feeding network, is in this embodiment provided by a separate discrete capacitor 90. An advantage of this  
20 embodiment is that the capacitance can be set to any desired value, without using an disproportionately large part of the substrate surface. A disadvantage of this embodiment however, as compared to the previous embodiments, is the need for additional steps in the manufacturing process.

25  
Although the invention has been described in conjunction with a number of preferred embodiments, it is to be understood that various modifications may still be made without departing from the scope of the invention as defined by the appended claims.  
30 One such possible modification is applying the feeding network, as described in the present invention, to multiple band antennas constituted by antenna elements which are neither of helix nor of meander type, but of some other shape,

such as whip antennas, or applying it to multiple band antennas constituted by combinations of different types of antenna elements, or to combinations of multiple band antennas with fixed and retractable portions.

## CLAIMS

1. A multiple frequency band antenna, comprising at least two antenna elements connected via an antenna feeding network to a radio frequency source/receiver, said antenna elements being operable in at least two non-overlapping frequency bands, **characterised in** that
- 5
- said antenna feeding network comprises means for connection to the radio frequency source/receiver, means for direct electrical connection to a feed-end portion of a first antenna element being operable in a lowermost frequency band, and means for capacitive coupling (24) to a feed-end portion of at least a second antenna element being operable in a frequency band which is higher than said lowermost frequency band,
  - said capacitive coupling being dimensioned to provide a relatively high impedance for frequencies in said lowermost frequency band and a relatively low impedance for frequencies in said higher frequency band.
- 10
- 15
- 20
2. The multiple frequency band antenna according to claim 1, **characterised in** that said at least two antenna elements are situated side-by-side in close proximity to each other.
- 25
3. The multiple frequency band antenna according to claim 1, **characterised in** that said at least two antenna elements are nested inside each other.
- 30

4. The multiple frequency band antenna according to any one of claims 1 through 3, **characterised in** that said at least two antenna elements are helix antenna elements.

5 5. The multiple frequency band antenna according to claim 4, **characterised in** that

- said antenna feeding network comprises at least two concentric coil necks (12, 13) being nested inside each other constituting the feed-end portions of said helix antenna elements,
  - 10 - said coil necks being capacitively coupled to each other through a dielectric medium (14), and
  - one of said coil necks (12, 13) being directly electrically connected to said radio frequency source/receiver.
- 15

6. The multiple frequency band antenna according to any one of claims 1 through 3, **characterised in** that

- said at least two antenna elements are meander antenna elements,
- 20 - each in the form of a conductive layer on a substrate.

7. The multiple frequency band antenna according to claim 6, **characterised in** that said at least two meander antenna elements are located on the same side of said substrate.

25

8. The multiple frequency band antenna according to claim 7, **characterised in** that said means for connection to the radio frequency source/receiver is located on the opposite side of said substrate.

30

9. The multiple frequency band antenna according to claim 6, **characterised in** that

- said at least two antenna elements are located on opposite sides of said substrate,
- 5 - said second antenna element being capacitively coupled to said feeding network through the substrate.

10. The multiple frequency band antenna according to claim 7, **characterised in** that said substrate extends circumferentially more than one full turn, such that said second antenna element is capacitively coupled to said feeding network through the substrate.

15 11. The multiple frequency band antenna according to any of claims 6, through 9, **characterised in** that the portion of said feeding network providing capacitive coupling between the antenna elements is provided by a discrete capacitor (90).

20 12. The multiple frequency band antenna according to any of claims 6, through 9, **characterised in** that said means for connection to the radio frequency source/receiver comprises a conductive portion extending through the substrate to said first element.

25 13. A mobile telephone having an antenna according to any one of the preceding claims.

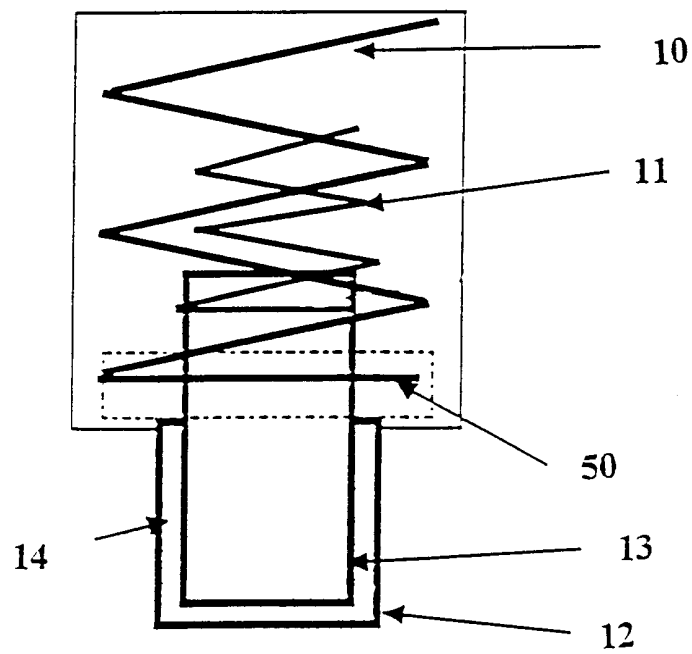

Fig. 1





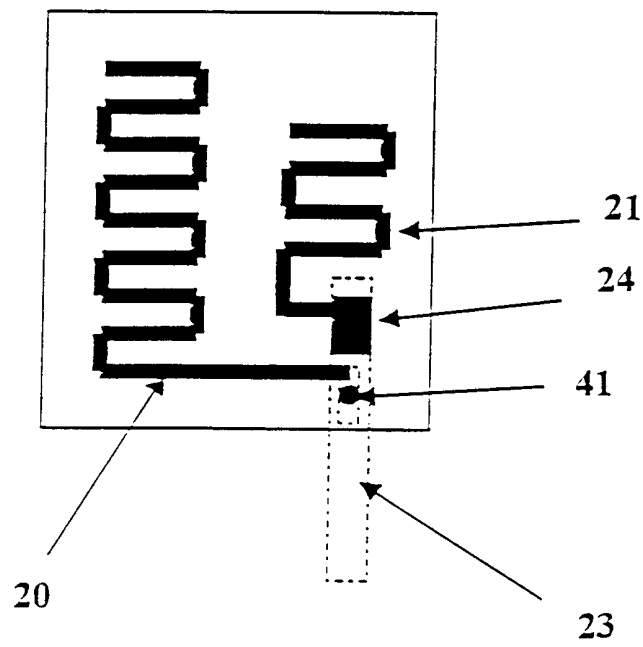

Fig. 3

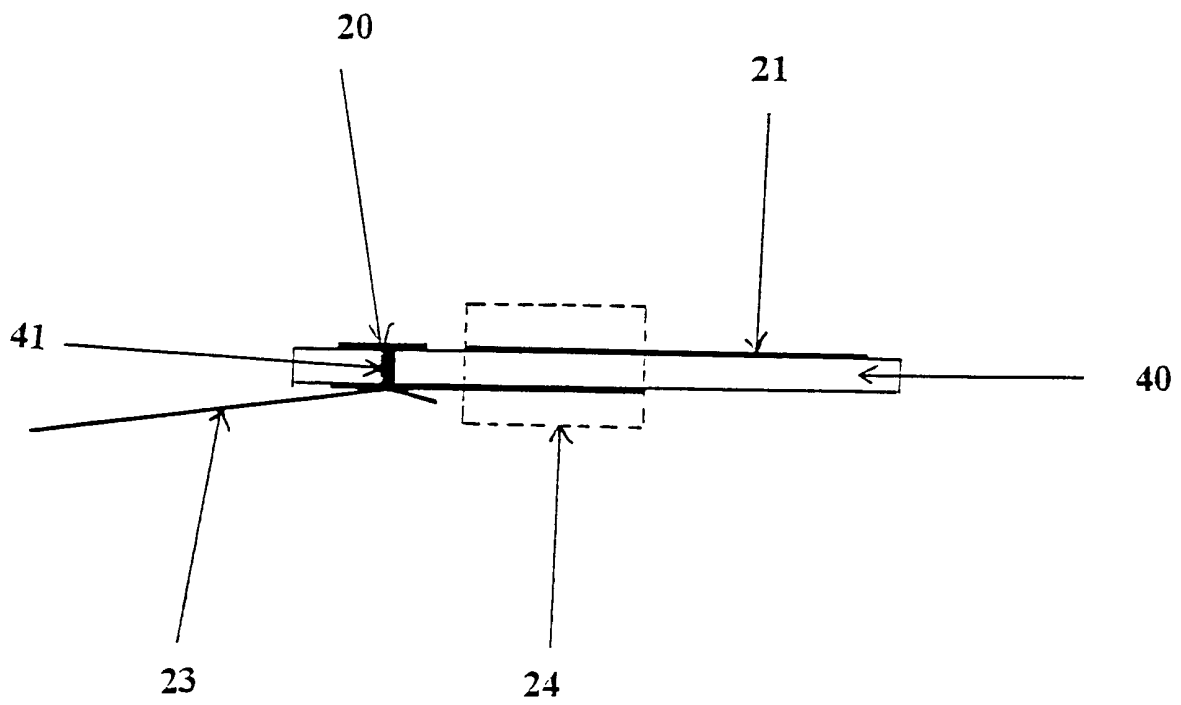

Fig. 4

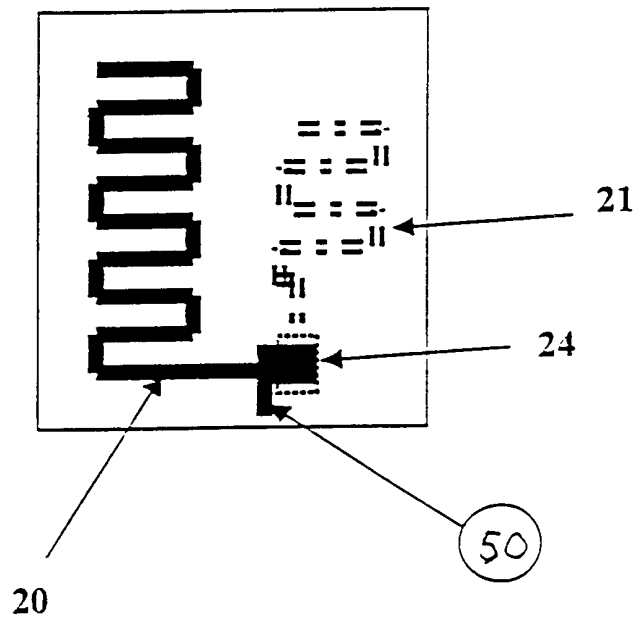

Fig. 5

6/9

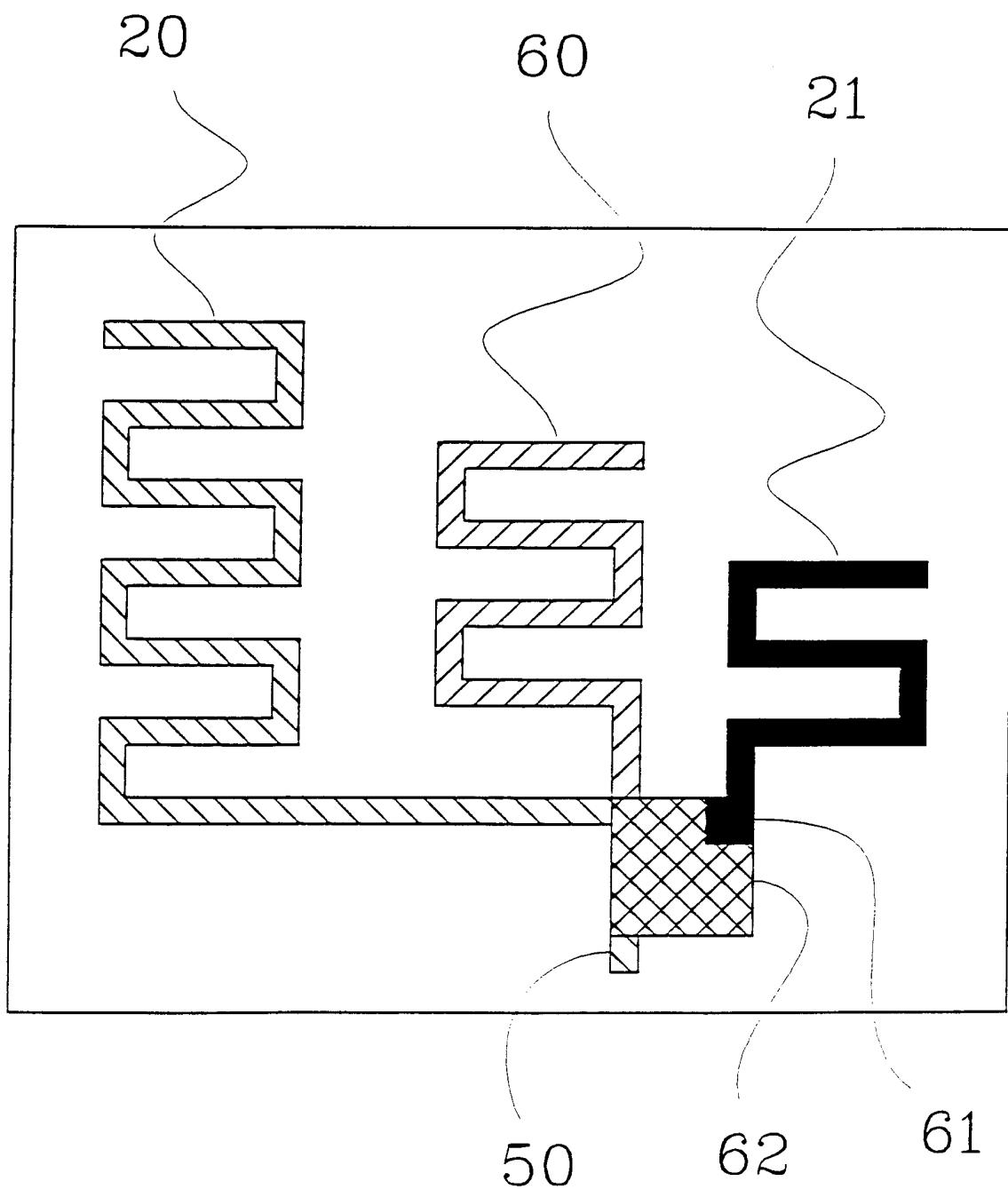

Fig. 6

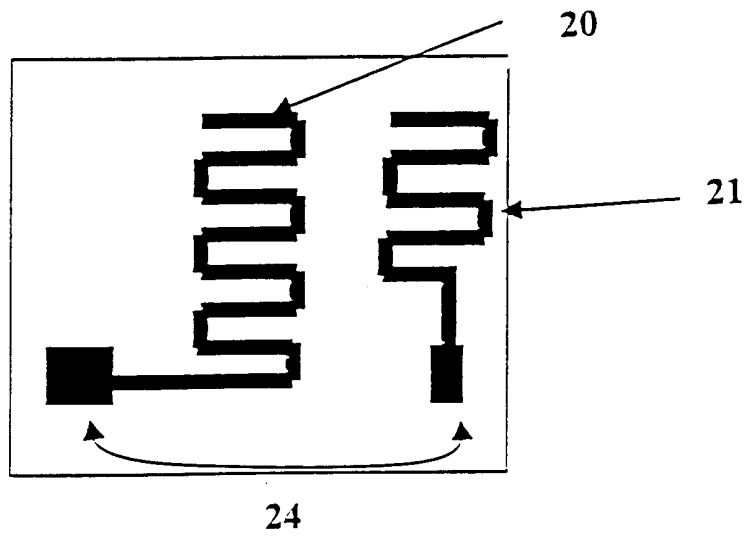

Fig. 7

8/9

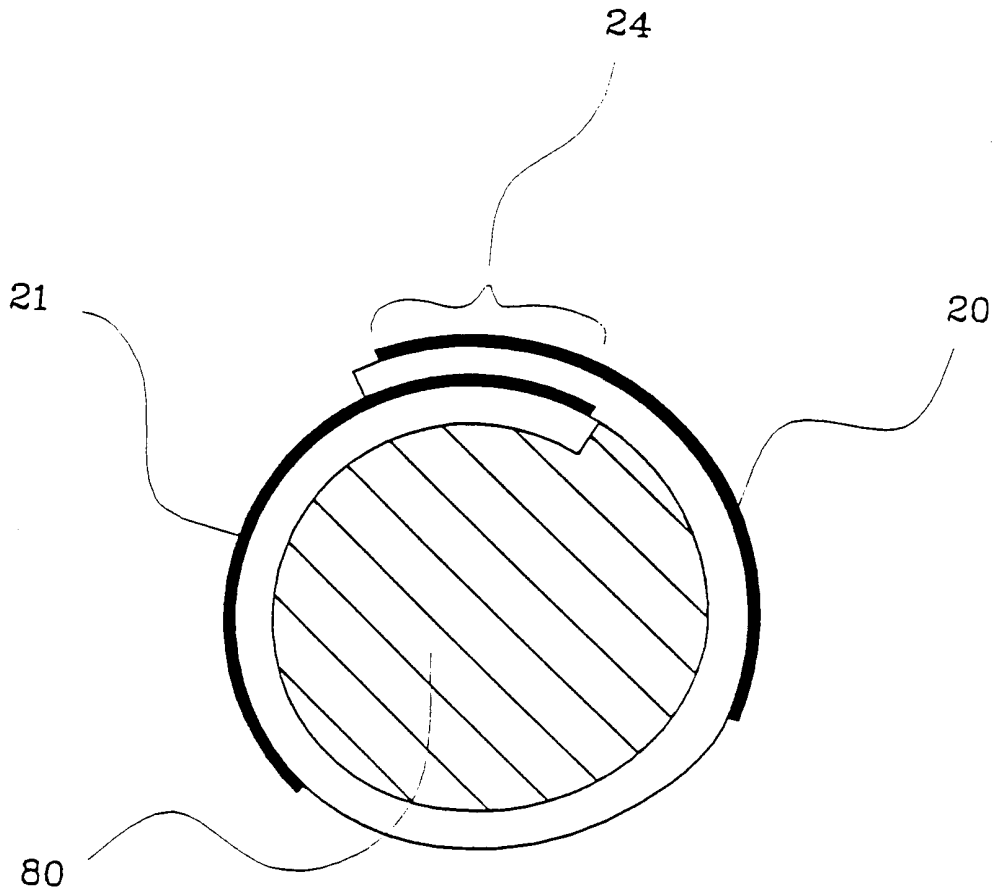

Fig. 8

9/9

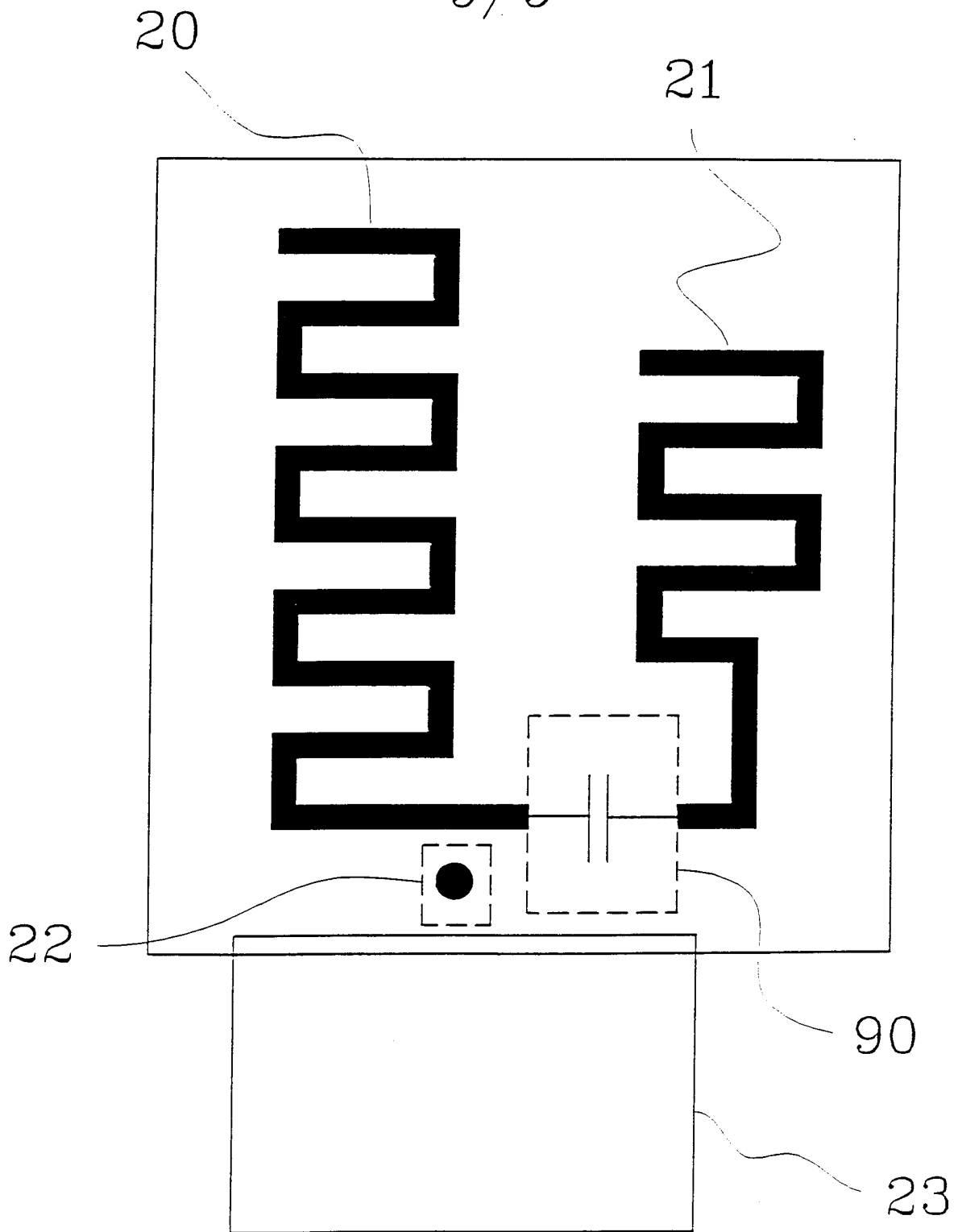

Fig. 9

## INTERNATIONAL SEARCH REPORT

International application No.

PCT/SE 00/01543

## A. CLASSIFICATION OF SUBJECT MATTER

IPC7: H01Q 5/00

According to International Patent Classification (IPC) or to both national classification and IPC

## B. FIELDS SEARCHED

Minimum documentation searched (classification system followed by classification symbols)

IPC7: H01Q

Documentation searched other than minimum documentation to the extent that such documents are included in the fields searched

SE,DK,FI,NO classes as above

Electronic data base consulted during the international search (name of data base and, where practicable, search terms used)

## C. DOCUMENTS CONSIDERED TO BE RELEVANT

Category*	Citation of document, with indication, where appropriate, of the relevant passages	Relevant to claim No.
A	WO 9629756 A1 (MINNESOTA MINING AND MANUFACTURING COMPANY), 26 Sept 1996 (26.09.96), abstract --	1-13
A	WO 9849747 A1 (GALTRONICS LTD.), 5 November 1998 (05.11.98), cited in the application --	1-13
A	WO 9926314 A1 (MOTECO AB), 27 May 1999 (27.05.99), cited in the application -- -----	1-13

 Further documents are listed in the continuation of Box C.
  See patent family annex.

\* Special categories of cited documents:

"A" document defining the general state of the art which is not considered to be of particular relevance

"E" earlier application or patent but published on or after the international filing date

"L" document which may throw doubts on priority claim(s) or which is cited to establish the publication date of another citation or other special reason (as specified)

"O" document referring to an oral disclosure, use, exhibition or other means

"P" document published prior to the international filing date but later than the priority date claimed

"T" later document published after the international filing date or priority date and not in conflict with the application but cited to understand the principle or theory underlying the invention

"X" document of particular relevance: the claimed invention cannot be considered novel or cannot be considered to involve an inventive step when the document is taken alone

"Y" document of particular relevance: the claimed invention cannot be considered to involve an inventive step when the document is combined with one or more other such documents, such combination being obvious to a person skilled in the art

"&" document member of the same patent family

Date of the actual completion of the international search

7 November 2000

Date of mailing of the international search report

16.11.00

Name and mailing address of the ISA/

Swedish Patent Office  
Box 5055, S-102 42 STOCKHOLM  
Facsimile No. +46 8 666 02 86

Authorized officer

Rune Bengtsson/AE  
Telephone No. +46 8 782 25 00



## INTERNATIONAL SEARCH REPORT

Information on patent family members

03/10/00

International application No.

PCT/SE 00/01543

WO	9629756	A1	26/09/96	AU	696840	B	17/09/98
				AU	5174896	A	08/10/96
				BR	9607695	A	07/07/98
				CA	2213848	A	26/09/96
				EP	0815613	A	07/01/98
				JP	11502386	T	23/02/99
-----							
WO	9849747	A1	05/11/98	AU	7076798	A	24/11/98
				IL	120737	D	00/00/00
				US	6075488	A	13/06/00
-----							
WO	9926314	A1	27/05/99	SE	513368	C	04/09/00
				SE	9704167	A	10/06/99
-----							