

(19) World Intellectual Property Organization  
International Bureau



(43) International Publication Date  
13 June 2002 (13.06.2002)

PCT

(10) International Publication Number  
WO 02/47059 A1

- (51) International Patent Classification<sup>7</sup>: G09G 3/10
- (74) Agent: MARCOU, George; Kilpatrick Stockton LLP, 607 Fourteenth St., N.W., Suite 900, Washington, DC 20005 (US).
- (21) International Application Number: PCT/US01/42807
- (22) International Filing Date: 26 October 2001 (26.10.2001)
- (81) Designated States (*national*): AE, AG, AL, AM, AT, AU, AZ, BA, BB, BG, BR, BY, BZ, CA, CH, CN, CO, CR, CU, CZ, DE, DK, DM, DZ, EC, EE, ES, FI, GB, GD, GE, GH, GM, HR, HU, ID, IL, IN, IS, JP, KE, KG, KP, KR, KZ, LC, LK, LR, LS, LT, LU, LV, MA, MD, MG, MK, MN, MW, MX, MZ, NO, NZ, PH, PL, PT, RO, RU, SD, SE, SG, SI, SK, SL, TJ, TM, TR, TT, TZ, UA, UG, UZ, VN, YU, ZA, ZW.
- (25) Filing Language: English
- (26) Publication Language: English
- (30) Priority Data: 09/697,345 27 October 2000 (27.10.2000) US
- (71) Applicant: SCIENCE APPLICATIONS INTERNATIONAL CORPORATION [US/US]; 10260 Campus Point Drive, San Diego, CA 92121 (US).
- (84) Designated States (*regional*): ARIPO patent (GH, GM, KE, LS, MW, MZ, SD, SL, SZ, TZ, UG, ZW), Eurasian patent (AM, AZ, BY, KG, KZ, MD, RU, TJ, TM), European patent (AT, BE, CH, CY, DE, DK, ES, FI, FR, GB, GR, IE, IT, LU, MC, NL, PT, SE, TR), OAPI patent (BF, BJ, CF, CG, CI, CM, GA, GN, GQ, GW, ML, MR, NE, SN, TD, TG).
- (72) Inventors: GEORGE, Edward, Victor; 28460 North Bay Road, Lake Arrowhead, CA 92352 (US). JOHNSON, Roger, Laverne; 82 McNeill Avenue, Encinitas, CA 92024 (US). GREEN, Albert, Myron; 7574 Woodstown Drive, Springfield, VA 22153 (US). WYETH, Newell, Convers; 3234 Hickory Drive, Oakton, VA 22124-2209 (US).
- Published: — with international search report

[Continued on next page]

(54) Title: A METHOD AND SYSTEM FOR ENERGIZING A MICRO-COMPONENT IN A LIGHT-EMITTING PANEL

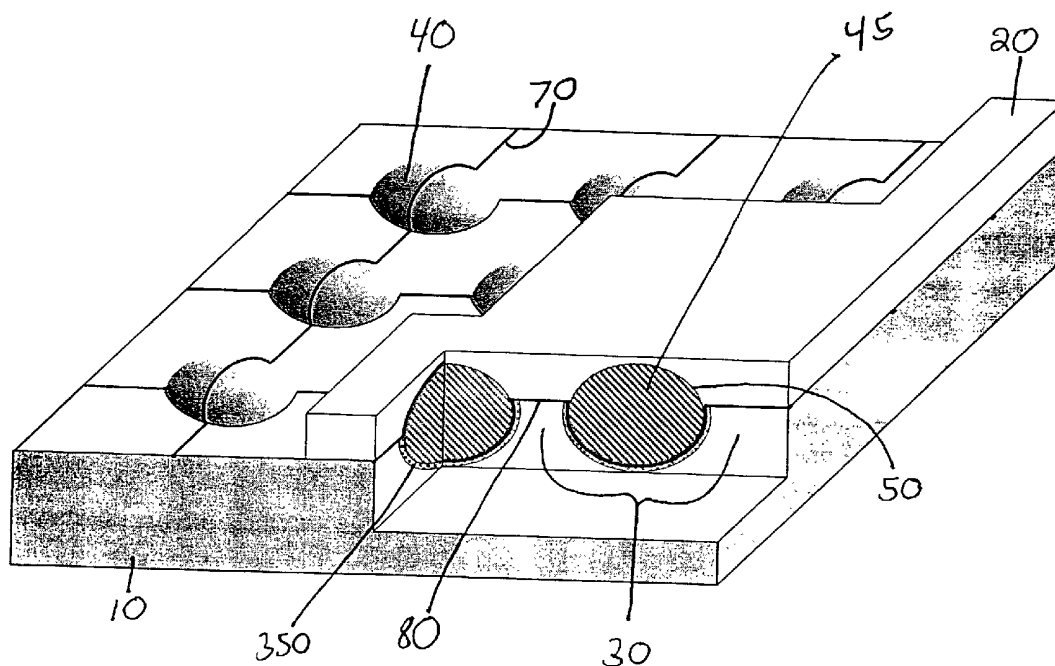

(57) Abstract: An improved light-emitting panel having a plurality of micro-components (40) sandwiched between two substrates (10, 20) is disclosed. Each micro-component (40) contains a gas or gas-mixture (45) capable of ionization when a sufficiently large voltage is supplied across the micro-component (40) via at least two electrodes. An improved method of energizing a micro-component is also disclosed.



WO 02/47059 A1



— *before the expiration of the time limit for amending the claims and to be republished in the event of receipt of amendments*

*For two-letter codes and other abbreviations, refer to the "Guidance Notes on Codes and Abbreviations" appearing at the beginning of each regular issue of the PCT Gazette.*

**A METHOD AND SYSTEM FOR ENERGIZING A MICRO-COMPONENT  
IN A LIGHT-EMITTING PANEL**

**CROSS-REFERENCE TO RELATED APPLICATIONS**

5           The following applications filed on the same date as the present application are herein incorporated by reference: *A Socket for Use with a Micro-Component in a Light-Emitting Panel* (Attorney Docket Number 203692); *A Micro-Component for Use in a Light-Emitting Panel* (Attorney Docket Number 203690); *A Method for Testing a Light-Emitting Panel and the Components Therein* (Attorney Docket Number 203686); and *A Light-Emitting Panel and*  
10 *Method of Making* (Attorney Docket Number 203694).

**BACKGROUND OF THE INVENTION**

**FIELD OF THE INVENTION**

15           The present invention is directed to a light-emitting panel and methods of fabricating the same. The present invention further relates to a method and system for energizing micro-components in a light-emitting panel.

**DESCRIPTION OF RELATED ART**

20           In a typical plasma display, a gas or mixture of gases is enclosed between orthogonally crossed and spaced conductors. The crossed conductors define a matrix of cross over points, arranged as an array of miniature picture elements (pixels), which provide light. At any given pixel, the orthogonally crossed and spaced conductors function as opposed plates of a capacitor, with the enclosed gas serving as a dielectric. When a sufficiently large voltage is applied, the gas at the pixel breaks down creating free electrons that are drawn to the positive  
25 conductor and positively charged gas ions that are drawn to the negatively charged conductor. These free electrons and positively charged gas ions collide with other gas atoms causing an avalanche effect creating still more free electrons and positively charged ions, thereby creating plasma. The voltage level at which this ionization occurs is called the write voltage.

-2-

Upon application of a write voltage, the gas at the pixel ionizes and emits light only briefly as free charges formed by the ionization migrate to the insulating dielectric walls of the cell where these charges produce an opposing voltage to the applied voltage and thereby extinguish the ionization. Once a pixel has been written, a continuous sequence of light emissions can be produced by an alternating sustain voltage. The amplitude of the sustain waveform can be less than the amplitude of the write voltage, because the wall charges that remain from the preceding write or sustain operation produce a voltage that adds to the voltage of the succeeding sustain waveform applied in the reverse polarity to produce the ionizing voltage. Mathematically, the idea can be set out as  $V_s = V_w - V_{wall}$ , where  $V_s$  is the sustain voltage,  $V_w$  is the write voltage, and  $V_{wall}$  is the wall voltage. Accordingly, a previously unwritten (or erased) pixel cannot be ionized by the sustain waveform alone. An erase operation can be thought of as a write operation that proceeds only far enough to allow the previously charged cell walls to discharge; it is similar to the write operation except for timing and amplitude.

Typically, there are two different arrangements of conductors that are used to perform the write, erase, and sustain operations. The one common element throughout the arrangements is that the sustain and the address electrodes are spaced apart with the plasma-forming gas in between. Thus, at least one of the address or sustain electrodes is located within the path the radiation travels, when the plasma-forming gas ionizes, as it exits the plasma display. Consequently, transparent or semi-transparent conductive materials must be used, such as indium tin oxide (ITO), so that the electrodes do not interfere with the displayed image from the plasma display. Using ITO, however, has several disadvantages, for example, ITO is expensive and adds significant cost to the manufacturing process and ultimately the final plasma display.

The first arrangement uses two orthogonally crossed conductors, one addressing conductor and one sustaining conductor. In a gas panel of this type, the sustain waveform is applied across all the addressing conductors and sustain conductors so that the gas panel maintains a previously written pattern of light emitting pixels. For a conventional write operation, a suitable write voltage pulse is added to the sustain voltage waveform so that the combination of the write pulse and the sustain pulse produces ionization. In order to write an individual pixel independently, each of the addressing and sustain conductors has an individual

selection circuit. Thus, applying a sustain waveform across all the addressing and sustain conductors, but applying a write pulse across only one addressing and one sustain conductor will produce a write operation in only the one pixel at the intersection of the selected addressing and sustain conductors.

5           The second arrangement uses three conductors. In panels of this type, called coplanar sustaining panels, each pixel is formed at the intersection of three conductors, one addressing conductor and two parallel sustaining conductors. In this arrangement, the addressing conductor orthogonally crosses the two parallel sustaining conductors. With this type of panel, the sustain function is performed between the two parallel sustaining conductors and the addressing is done  
10 by the generation of discharges between the addressing conductor and one of the two parallel sustaining conductors.

The sustaining conductors are of two types, addressing-sustaining conductors and solely sustaining conductors. The function of the addressing-sustaining conductors is twofold: to achieve a sustaining discharge in cooperation with the solely sustaining conductors; and to fulfill  
15 an addressing role. Consequently, the addressing-sustaining conductors are individually selectable so that an addressing waveform may be applied to any one or more addressing-sustaining conductors. The solely sustaining conductors, on the other hand, are typically connected in such a way that a sustaining waveform can be simultaneously applied to all of the solely sustaining conductors so that they can be carried to the same potential in the same instant.

20           Numerous types of plasma panel display devices have been constructed with a variety of methods for enclosing a plasma forming gas between sets of electrodes. In one type of plasma display panel, parallel plates of glass with wire electrodes on the surfaces thereof are spaced uniformly apart and sealed together at the outer edges with the plasma forming gas filling the cavity formed between the parallel plates. Although widely used, this type of open display  
25 structure has various disadvantages. The sealing of the outer edges of the parallel plates and the introduction of the plasma forming gas are both expensive and time-consuming processes, resulting in a costly end product. In addition, it is particularly difficult to achieve a good seal at the sites where the electrodes are fed through the ends of the parallel plates. This can result in gas leakage and a shortened product lifecycle. Another disadvantage is that individual pixels are

not segregated within the parallel plates. As a result, gas ionization activity in a selected pixel during a write operation may spill over to adjacent pixels, thereby raising the undesirable prospect of possibly igniting adjacent pixels. Even if adjacent pixels are not ignited, the ionization activity can change the turn-on and turn-off characteristics of the nearby pixels.

5           In another type of known plasma display, individual pixels are mechanically isolated either by forming trenches in one of the parallel plates or by adding a perforated insulating layer sandwiched between the parallel plates. These mechanically isolated pixels, however, are not completely enclosed or isolated from one another because there is a need for the free passage of the plasma forming gas between the pixels to assure uniform gas pressure throughout the panel.

10          While this type of display structure decreases spill over, spill over is still possible because the pixels are not in total electrical isolation from one another. In addition, in this type of display panel it is difficult to properly align the electrodes and the gas chambers, which may cause pixels to misfire. As with the open display structure, it is also difficult to get a good seal at the plate edges. Furthermore, it is expensive and time consuming to introduce the plasma producing gas

15          and seal the outer edges of the parallel plates.

          In yet another type of known plasma display, individual pixels are also mechanically isolated between parallel plates. In this type of display, the plasma forming gas is contained in transparent spheres formed of a closed transparent shell. Various methods have been used to contain the gas filled spheres between the parallel plates. In one method, spheres of varying sizes

20          are tightly bunched and randomly distributed throughout a single layer, and sandwiched between the parallel plates. In a second method, spheres are embedded in a sheet of transparent dielectric material and that material is then sandwiched between the parallel plates. In a third method, a perforated sheet of electrically nonconductive material is sandwiched between the parallel plates with the gas filled spheres distributed in the perforations.

25          While each of the types of displays discussed above are based on different design concepts, the manufacturing approach used in their fabrication is generally the same. Conventionally, a batch fabrication process is used to manufacture these types of plasma panels. As is well known in the art, in a batch process individual component parts are fabricated separately, often in different facilities and by different manufacturers, and then brought together

for final assembly where individual plasma panels are created one at a time. Batch processing has numerous shortcomings, such as, for example, the length of time necessary to produce a finished product. Long cycle times increase product cost and are undesirable for numerous additional reasons known in the art. For example, a sizeable quantity of substandard, defective, or useless fully or partially completed plasma panels may be produced during the period between detection of a defect or failure in one of the components and an effective correction of the defect or failure.

This is especially true of the first two types of displays discussed above; the first having no mechanical isolation of individual pixels, and the second with individual pixels mechanically isolated either by trenches formed in one parallel plate or by a perforated insulating layer sandwiched between two parallel plates. Due to the fact that plasma-forming gas is not isolated at the individual pixel/subpixel level, the fabrication process precludes the majority of individual component parts from being tested until the final display is assembled. Consequently, the display can only be tested after the two parallel plates are sealed together and the plasma-forming gas is filled inside the cavity between the two plates. If post production testing shows that any number of potential problems have occurred, (e.g. poor luminescence or no luminescence at specific pixels/subpixels) the entire display is discarded.

### BRIEF SUMMARY OF THE INVENTION

Preferred embodiments of the present invention provide a light-emitting panel that may be used as a large-area radiation source, for energy modulation, for particle detection and as a flat-panel display. Gas-plasma panels are preferred for these applications due to their unique characteristics.

In one form, the light-emitting panel may be used as a large area radiation source. By configuring the light-emitting panel to emit ultraviolet (UV) light, the panel has application for curing, painting, and sterilization. With the addition of a white phosphor coating to convert the UV light to visible white light, the panel also has application as an illumination source.

In addition, the light-emitting panel may be used as a plasma-switched phase array by configuring the panel in at least one embodiment in a microwave transmission mode. The panel

is configured in such a way that during ionization the plasma-forming gas creates a localized index of refraction change for the microwaves (although other wavelengths of light would work). The microwave beam from the panel can then be steered or directed in any desirable pattern by introducing at a localized area a phase shift and/or directing the microwaves out of a specific aperture in the panel

5  
10 Additionally, the light-emitting panel may be used for particle/photon detection. In this embodiment, the light-emitting panel is subjected to a potential that is just slightly below the write voltage required for ionization. When the device is subjected to outside energy at a specific position or location in the panel, that additional energy causes the plasma forming gas in the specific area to ionize, thereby providing a means of detecting outside energy.

15 Further, the light-emitting panel may be used in flat-panel displays. These displays can be manufactured very thin and lightweight, when compared to similar sized cathode ray tube (CRTs), making them ideally suited for home, office, theaters and billboards. In addition, these displays can be manufactured in large sizes and with sufficient resolution to accommodate high-definition television (HDTV). Gas-plasma panels do not suffer from electromagnetic distortions and are, therefore, suitable for applications strongly affected by magnetic fields, such as military applications, radar systems, railway stations and other underground systems.

20 According to one general embodiment of the present invention, a light-emitting panel is made from two substrates, wherein one of the substrates includes a plurality of sockets and wherein at least two electrodes are disposed. At least partially disposed in each socket is a micro-component, although more than one micro-component may be disposed therein. Each micro-component includes a shell at least partially filled with a gas or gas mixture capable of ionization. When a large enough voltage is applied across the micro-component the gas or gas mixture ionizes forming plasma and emitting radiation.

25 In an embodiment of the present invention, the plurality of sockets include a cavity that is patterned in the first substrate and at least two electrodes adhered to the first substrate, the second substrate or any combination thereof.

In another embodiment, the plurality of sockets include a cavity that is patterned in the first substrate and at least two electrodes that are arranged so that voltage supplied to the



electrodes causes at least one micro-component to emit radiation throughout the field of view of the light-emitting panel without the radiation crossing the electrodes.

In another embodiment, a first substrate comprises a plurality of material layers and a socket is formed by selectively removing a portion of the plurality of material layers to form a cavity and disposing at least one electrode on or within the material layers.

In another embodiment, a socket includes a cavity patterned in a first substrate, a plurality of material layers disposed on the first substrate so that the plurality of material layers conform to the shape of the socket and at least one electrode disposed within the material layers.

In another embodiment, a plurality of material layers, each including an aperture, are disposed on a substrate. In this embodiment, the material layers are disposed so that the apertures are aligned, thereby forming a cavity.

Other embodiments are directed to methods for energizing a micro-component in a light-emitting display using the socket configurations described above with voltage provided to at least two electrodes causing at least one micro-component at least partially disposed in the cavity of a socket to emit radiation.

Other features, advantages, and embodiments of the invention are set forth in part in the description that follows, and in part, will be obvious from this description, or may be learned from the practice of the invention.

20

### **BRIEF DESCRIPTION OF THE DRAWINGS**

The foregoing and other objects, features and advantages of this invention will become more apparent by reference to the following detailed description of the invention taken in conjunction with the accompanying drawings, wherein:

25 FIG. 1 depicts a portion of a light-emitting panel showing the basic socket structure of a socket formed from patterning a substrate, as disclosed in an embodiment of the present invention.

FIG. 2 depicts a portion of a light-emitting panel showing the basic socket structure of a socket formed from patterning a substrate, as disclosed in another embodiment of the present invention.

FIG. 3A shows an example of a cavity that has a cube shape.

FIG. 3B shows an example of a cavity that has a cone shape.

5

FIG. 3C shows an example of a cavity that has a conical frustum shape.

FIG. 3D shows an example of a cavity that has a paraboloid shape.

10 FIG. 3E shows an example of a cavity that has a spherical shape.

FIG. 3F shows an example of a cavity that has a cylindrical shape.

FIG. 3G shows an example of a cavity that has a pyramid shape.

15

FIG. 3H shows an example of a cavity that has a pyramidal frustum shape.

FIG. 3I shows an example of a cavity that has a parallelepiped shape.

20 FIG. 3J shows an example of a cavity that has a prism shape.

FIG. 4 shows the socket structure from a light-emitting panel of an embodiment of the present invention with a narrower field of view.

25 FIG. 5 shows the socket structure from a light-emitting panel of an embodiment of the present invention with a wider field of view.

FIG. 6A depicts a portion of a light-emitting panel showing the basic socket structure of a socket formed from disposing a plurality of material layers and then selectively removing a portion of  
30 the material layers with the electrodes having a co-planar configuration.

FIG. 6B is a cut-away of FIG. 6A showing in more detail the co-planar sustaining electrodes.

5 FIG. 7A depicts a portion of a light-emitting panel showing the basic socket structure of a socket formed from disposing a plurality of material layers and then selectively removing a portion of the material layers with the electrodes having a mid-plane configuration.

FIG. 7B is a cut-away of FIG. 7A showing in more detail the uppermost sustain electrode.

10 FIG. 8 depicts a portion of a light-emitting panel showing the basic socket structure of a socket formed from disposing a plurality of material layers and then selectively removing a portion of the material layers with the electrodes having an configuration with two sustain and two address electrodes, where the address electrodes are between the two sustain electrodes.

15 FIG. 9 depicts a portion of a light-emitting panel showing the basic socket structure of a socket formed from patterning a substrate and then disposing a plurality of material layers on the substrate so that the material layers conform to the shape of the cavity with the electrodes having a co-planar configuration.

20 FIG. 10 depicts a portion of a light-emitting panel showing the basic socket structure of a socket formed from patterning a substrate and then disposing a plurality of material layers on the substrate so that the material layers conform to the shape of the cavity with the electrodes having a mid-plane configuration.

25 FIG. 11 depicts a portion of a light-emitting panel showing the basic socket structure of a socket formed from patterning a substrate and then disposing a plurality of material layers on the substrate so that the material layers conform to the shape of the cavity with the electrodes having an configuration with two sustain and two address electrodes, where the address electrodes are between the two sustain electrodes.

FIG. 12 shows an exploded view of a portion of a light-emitting panel showing the basic socket structure of a socket formed by disposing a plurality of material layers with aligned apertures on a substrate with the electrodes having a co-planar configuration.

5 FIG. 13 shows an exploded view of a portion of a light-emitting panel showing the basic socket structure of a socket formed by disposing a plurality of material layers with aligned apertures on a substrate with the electrodes having a mid-plane configuration.

10 FIG. 14 shows an exploded view of a portion of a light-emitting panel showing the basic socket structure of a socket formed by disposing a plurality of material layers with aligned apertures on a substrate with electrodes having a configuration with two sustain and two address electrodes, where the address electrodes are between the two sustain electrodes.

15 **DETAILED DESCRIPTION OF THE PREFERRED EMBODIMENTS**  
**OF THE INVENTION**

As embodied and broadly described herein, the preferred embodiments of the present invention are directed to a novel light-emitting panel. In particular, preferred embodiments are directed to light-emitting panels and to a web fabrication process for manufacturing light-emitting panels.  
20

Figs. 1 and 2 show two embodiments of the present invention wherein a light-emitting panel includes a first substrate 10 and a second substrate 20. The first substrate 10 may be made from silicates, polypropylene, quartz, glass, any polymeric-based material or any material or combination of materials known to one skilled in the art. Similarly, second substrate 20 may be  
25 made from silicates, polypropylene, quartz, glass, any polymeric-based material or any material or combination of materials known to one skilled in the art. First substrate 10 and second substrate 20 may both be made from the same material or each of a different material. Additionally, the first and second substrate may be made of a material that dissipates heat from

the light-emitting panel. In a preferred embodiment, each substrate is made from a material that is mechanically flexible.

The first substrate 10 includes a plurality of sockets 30. The sockets 30 may be disposed in any pattern, having uniform or non-uniform spacing between adjacent sockets. Patterns may include, but are not limited to, alphanumeric characters, symbols, icons, or pictures. Preferably, the sockets 30 are disposed in the first substrate 10 so that the distance between adjacent sockets 30 is approximately equal. Sockets 30 may also be disposed in groups such that the distance between one group of sockets and another group of sockets is approximately equal. This latter approach may be particularly relevant in color light-emitting panels, where each socket in each group of sockets may represent red, green and blue, respectively.

At least partially disposed in each socket 30 is at least one micro-component 40. Multiple micro-components may be disposed in a socket to provide increased luminosity and enhanced radiation transport efficiency. In a color light-emitting panel according to one embodiment of the present invention, a single socket supports three micro-components configured to emit red, green, and blue light, respectively. The micro-components 40 may be of any shape, including, but not limited to, spherical, cylindrical, and aspherical. In addition, it is contemplated that a micro-component 40 includes a micro-component placed or formed inside another structure, such as placing a spherical micro-component inside a cylindrical-shaped structure. In a color light-emitting panel according to an embodiment of the present invention, each cylindrical-shaped structure holds micro-components configured to emit a single color of visible light or multiple colors arranged red, green, blue, or in some other suitable color arrangement.

In its most basic form, each micro-component 40 includes a shell 50 filled with a plasma-forming gas or gas mixture 45. Any suitable gas or gas mixture 45 capable of ionization may be used as the plasma-forming gas, including, but not limited to, krypton, xenon, argon, neon, oxygen, helium, mercury, and mixtures thereof. In fact, any noble gas could be used as the plasma-forming gas, including, but not limited to, noble gases mixed with cesium or mercury. One skilled in the art would recognize other gasses or gas mixtures that could also be used. While a plasma-forming gas or gas mixture 45 is used in a preferred embodiment, any other material capable of providing luminescence is also contemplated, such as an electro-luminescent material, organic light-emitting diodes (OLEDs), or an electro-phoretic material.

There are a variety of coatings 300 and dopants that may be added to a micro-component 40 that also influence the performance and characteristics of the light-emitting panel. The coatings 300 may be applied to the outside or inside of the shell 50, and may either partially or fully coat the shell 50. Alternatively, or in combination with the coatings and dopants that may be added to a micro-component 40, a variety of coatings 350 may be disposed on the inside of a socket 30. These coatings 350 include, but are not limited to, coatings used to convert UV light to visible light, coatings used as reflecting filters, and coatings used as band-gap filters.

A cavity 55 formed within and/or on the first substrate 10 provides the basic socket 30 structure. The cavity 55 may be any shape and size. As depicted in Figs. 3A-3J, the shape of the cavity 55 may include, but is not limited to, a cube 100, a cone 110, a conical frustum 120, a paraboloid 130, spherical 140, cylindrical 150, a pyramid 160, a pyramidal frustum 170, a parallelepiped 180, or a prism 190.

The size and shape of the socket 30 influence the performance and characteristics of the light-emitting panel and are selected to optimize the panel's efficiency of operation. In addition, socket geometry may be selected based on the shape and size of the micro-component to optimize the surface contact between the micro-component and the socket and/or to ensure connectivity of the micro-component and any electrodes disposed within the socket. Further, the size and shape of the sockets 30 may be chosen to optimize photon generation and provide increased luminosity and radiation transport efficiency. As shown by example in Figs. 4 and 5, the size and shape may be chosen to provide a field of view 400 with a specific angle  $\theta$ , such that a micro-component 40 disposed in a deep socket 30 may provide more collimated light and hence a narrower viewing angle  $\theta$  (Fig. 4), while a micro-component 40 disposed in a shallow socket 30 may provide a wider viewing angle  $\theta$  (Fig. 5). That is to say, the cavity may be sized, for example, so that its depth subsumes a micro-component deposited in a socket, or it may be made shallow so that a micro-component is only partially disposed within a socket.

In an embodiment for a light-emitting panel, a cavity 55 is formed, or patterned, in a substrate 10 to create a basic socket shape. The cavity may be formed in any suitable shape and size by any combination of physically, mechanically, thermally, electrically, optically, or chemically deforming the substrate. Disposed proximate to, and/or in, each socket may be a variety of enhancement materials 325. The enhancement materials 325 include, but are not

limited to, anti-glare coatings, touch sensitive surfaces, contrast enhancement coatings, protective coatings, transistors, integrated-circuits, semiconductor devices, inductors, capacitors, resistors, control electronics, drive electronics, diodes, pulse-forming networks, pulse compressors, pulse transformers, and tuned-circuits.

5           In another embodiment of the present invention for a light-emitting panel, a socket 30 is formed by disposing a plurality of material layers 60 to form a first substrate 10, disposing at least one electrode either on or within the material layers, and selectively removing a portion of the material layers 60 to create a cavity. The material layers 60 include any combination, in whole or in part, of dielectric materials, metals, and enhancement materials 325. The  
10   enhancement materials 325 include, but are not limited to, anti-glare coatings, touch sensitive surfaces, contrast enhancement coatings, protective coatings, transistors, integrated-circuits, semiconductor devices, inductors, capacitors, resistors, control electronics, drive electronics, diodes, pulse-forming networks, pulse compressors, pulse transformers, and tuned-circuits. The placement of the material layers 60 may be accomplished by any transfer process,  
15   photolithography, sputtering, laser deposition, chemical deposition, vapor deposition, or deposition using ink jet technology. One of general skill in the art will recognize other appropriate methods of disposing a plurality of material layers. The cavity 55 may be formed in the material layers 60 by a variety of methods including, but not limited to, wet or dry etching, photolithography, laser heat treatment, thermal form, mechanical punch, embossing, stamping-  
20   out, drilling, electroforming or by dimpling.

          In another embodiment of the present invention for a light-emitting panel, a socket 30 is formed by patterning a cavity 55 in a first substrate 10, disposing a plurality of material layers 65 on the first substrate 10 so that the material layers 65 conform to the cavity 55, and disposing at least one electrode on the first substrate 10, within the material layers 65, or any combination  
25   thereof. The cavity may be formed in any suitable shape and size by any combination of physically, mechanically, thermally, electrically, optically, or chemically deforming the substrate. The material layers 60 include any combination, in whole or in part, of dielectric materials, metals, and enhancement materials 325. The enhancement materials 325 include, but are not limited to, anti-glare coatings, touch sensitive surfaces, contrast enhancement coatings, protective  
30   coatings, transistors, integrated-circuits, semiconductor devices, inductors, capacitors, resistors,

control electronics, drive electronics, diodes, pulse-forming networks, pulse compressors, pulse transformers, and tuned-circuits. The placement of the material layers 60 may be accomplished by any transfer process, photolithography, sputtering, laser deposition, chemical deposition, vapor deposition, or deposition using ink jet technology. One of general skill in the art will  
5 recognize other appropriate methods of disposing a plurality of material layers on a substrate.

In another embodiment of the present invention for a method of making a light-emitting panel including a plurality of sockets, a socket 30 is formed by disposing a plurality of material layers 66 on a first substrate 10 and disposing at least one electrode on the first substrate 10, within the material layers 66, or any combination thereof. Each of the material layers includes a  
10 preformed aperture 56 that extends through the entire material layer. The apertures may be of the same size or may be of different sizes. The plurality of material layers 66 are disposed on the first substrate with the apertures in alignment thereby forming a cavity 55. The material layers 66 include any combination, in whole or in part, of dielectric materials, metals, and enhancement materials 325. The enhancement materials 325 include, but are not limited to, anti-glare  
15 coatings, touch sensitive surfaces, contrast enhancement coatings, protective coatings, transistors, integrated-circuits, semiconductor devices, inductors, capacitors, resistors, diodes, control electronics, drive electronics, pulse-forming networks, pulse compressors, pulse transformers, and tuned-circuits. The placement of the material layers 66 may be accomplished by any transfer process, photolithography, sputtering, laser deposition, chemical deposition, vapor deposition, or  
20 deposition using ink jet technology. One of general skill in the art will recognize other appropriate methods of disposing a plurality of material layers on a substrate.

In the above embodiments describing four different methods of making a socket in a light-emitting panel, disposed in, or proximate to, each socket may be at least one enhancement material. As stated above the enhancement material 325 may include, but is not limited to, anti-  
25 glare coatings, touch sensitive surfaces, contrast enhancement coatings, protective coatings, transistors, integrated-circuits, semiconductor devices, inductors, capacitors, resistors, control electronics, drive electronics, diodes, pulse-forming networks, pulse compressors, pulse transformers, and tuned-circuits. In a preferred embodiment of the present invention the enhancement materials may be disposed in, or proximate to each socket by any transfer process,  
30 photolithography, sputtering, laser deposition, chemical deposition, vapor deposition, deposition



using ink jet technology, or mechanical means. In another embodiment of the present invention, a method for making a light-emitting panel includes disposing at least one electrical enhancement (e.g. the transistors, integrated-circuits, semiconductor devices, inductors, capacitors, resistors, control electronics, drive electronics, diodes, pulse-forming networks, pulse compressors, pulse transformers, and tuned-circuits), in, or proximate to, each socket by suspending the at least one electrical enhancement in a liquid and flowing the liquid across the first substrate. As the liquid flows across the substrate the at least one electrical enhancement will settle in each socket. It is contemplated that other substances or means may be use to move the electrical enhancements across the substrate. One such means may include, but is not limited to, using air to move the electrical enhancements across the substrate. In another embodiment of the present invention the socket is of a corresponding shape to the at least one electrical enhancement such that the at least one electrical enhancement self-aligns with the socket.

The electrical enhancements may be used in a light-emitting panel for a number of purposes including, but not limited to, lowering the voltage necessary to ionize the plasma-forming gas in a micro-component, lowering the voltage required to sustain/erase the ionization charge in a micro-component, increasing the luminosity and/or radiation transport efficiency of a micro-component, and augmenting the frequency at which a micro-component is lit. In addition, the electrical enhancements may be used in conjunction with the light-emitting panel driving circuitry to alter the power requirements necessary to drive the light-emitting panel. For example, a tuned-circuit may be used in conjunction with the driving circuitry to allow a DC power source to power an AC-type light-emitting panel. In an embodiment of the present invention, a controller is provided that is connected to the electrical enhancements and capable of controlling their operation. Having the ability to individual control the electrical enhancements at each pixel/subpixel provides a means by which the characteristics of individual micro-components may be altered/corrected after fabrication of the light-emitting panel. These characteristics include, but are not limited to, luminosity and the frequency at which a micro-component is lit. One skilled in the art will recognize other uses for electrical enhancements disposed in, or proximate to, each socket in a light-emitting panel.

The electrical potential necessary to energize a micro-component 40 is supplied via at least two electrodes. The electrodes may be disposed in the light-emitting panel using any

technique known to one skilled in the art including, but not limited to, any transfer process, photolithography, sputtering, laser deposition, chemical deposition, vapor deposition, deposition using ink jet technology, or mechanical means. In a general embodiment of the present invention, a light-emitting panel includes a plurality of electrodes, wherein at least two electrodes are adhered to the first substrate, the second substrate or any combination thereof and wherein the electrodes are arranged so that voltage applied to the electrodes causes one or more micro-components to emit radiation. In another general embodiment, a light-emitting panel includes a plurality of electrodes, wherein at least two electrodes are arranged so that voltage supplied to the electrodes cause one or more micro-components to emit radiation throughout the field of view of the light-emitting panel without crossing either of the electrodes.

In an embodiment where the sockets 30 each include a cavity patterned in the first substrate 10, at least two electrodes may be disposed on the first substrate 10, the second substrate 20, or any combination thereof. In an embodiment for a method of energizing a micro-component, the electrodes may be disposed either before the cavity is formed or after the cavity is formed. In exemplary embodiments as shown in Figs. 1 and 2, a sustain electrode 70 is adhered on the second substrate 20 and an address electrode 80 is adhered on the first substrate 10. In a preferred embodiment, at least one electrode adhered to the first substrate 10 is at least partly disposed within the socket (Figs. 1 and 2).

In an embodiment where the first substrate 10 includes a plurality of material layers 60 and the sockets 30 are formed within the material layers, at least two electrodes may be disposed on the first substrate 10, disposed within the material layers 60, disposed on the second substrate 20, or any combination thereof. In one embodiment, as shown in Fig. 6A, a first address electrode 80 is disposed within the material layers 60, a first sustain electrode 70 is disposed within the material layers 60, and a second sustain electrode 75 is disposed within the material layers 60, such that the first sustain electrode and the second sustain electrode are in a co-planar configuration. Fig. 6B is a cut-away of Fig. 6A showing the arrangement of the co-planar sustain electrodes 70 and 75. In another embodiment, as shown in Fig. 7A, a first sustain electrode 70 is disposed on the first substrate 10, a first address electrode 80 is disposed within the material layers 60, and a second sustain electrode 75 is disposed within the material layers 60, such that the first address electrode is located between the first sustain electrode and the second sustain

electrode in a mid-plane configuration. Fig. 7B is a cut-away of Fig. 7A showing the first sustain electrode 70. In this mid-plane configuration, the sustain function will be performed by the two sustain electrodes much like in the co-planar configuration and the address function will be performed between at least one of the sustain electrodes and the address electrode. It is believed that energizing a micro-component with this arrangement of electrodes will produce increased luminosity. As seen in Fig. 8, in a preferred embodiment of the present invention, a first sustain electrode 70 is disposed within the material layers 60, a first address electrode 80 is disposed within the material layers 60, a second address electrode 85 is disposed within the material layers 60, and a second sustain electrode 75 is disposed within the material layers 60, such that the first address electrode and the second address electrode are located between the first sustain electrode and the second sustain electrode. This configuration completely separates the addressing function from the sustain electrodes. It is believed that this arrangement will provide a simpler and cheaper means of addressing, sustain and erasing, because complicated switching means will not be required since different voltage sources may be used for the sustain and address electrodes. It is also believed that by separating the sustain and address electrodes so different voltage sources may be used to provide the address and sustain functions, a lower or different type of voltage source may be used to provide the address or sustain functions.

In an embodiment where a cavity 55 is patterned in the first substrate 10 and a plurality of material layers 65 are disposed on the first substrate 10 so that the material layers conform to the cavity 55, at least two electrodes may be disposed on the first substrate 10, at least partially disposed within the material layers 65, disposed on the second substrate 20, or any combination thereof. In an embodiment for a method of energizing a micro-component, electrodes formed on the first substrate may be disposed either before the cavity was patterned or after the cavity was patterned. In one embodiment, as shown in Fig. 9, a first address electrode 80 is disposed on the first substrate 10, a first sustain electrode 70 is disposed within the material layers 65, and a second sustain electrode 75 is disposed within the material layers 65, such that the first sustain electrode and the second sustain electrode are in a co-planar configuration. In another embodiment, as shown in Fig. 10, a first sustain electrode 70 is disposed on the first substrate 10, a first address electrode 80 is disposed within the material layers 65, and a second sustain electrode 75 is disposed within the material layers 65, such that the first address electrode is

located between the first sustain electrode and the second sustain electrode in a mid-plane configuration. In this mid-plane configuration, the sustain function will be performed by the two sustain electrodes much like in the co-planar configuration and the address function will be performed between at least one of the sustain electrodes and the address electrode. It is believed that energizing a micro-component with this arrangement of electrodes will produce increased luminosity. As seen in Fig. 11, in a preferred embodiment of the present invention, a first sustain electrode 70 is disposed on the first substrate 10, a first address electrode 80 is disposed within the material layers 65, a second address electrode 85 is disposed within the material layers 65, and a second sustain electrode 75 is disposed within the material layers 65, such that the first address electrode and the second address electrode are located between the first sustain electrode and the second sustain electrode. This configuration completely separates the addressing function from the sustain electrodes. It is believed that this arrangement will provide a simpler and cheaper means of addressing, sustain and erasing, because complicated switching means will not be required since different voltage sources may be used for the sustain and address electrodes. It is also believed that by separating the sustain and address electrodes so different voltage sources may be used to provide the address and sustain functions a lower or different type of voltage source may be used to provide the address or sustain functions.

In an embodiment where a plurality of material layers 66 with aligned apertures 56 are disposed on a first substrate 10 thereby creating the cavities 55, at least two electrodes may be disposed on the first substrate 10, at least partially disposed within the material layers 65, disposed on the second substrate 20, or any combination thereof. In one embodiment, as shown in Fig. 12, a first address electrode 80 is disposed on the first substrate 10, a first sustain electrode 70 is disposed within the material layers 66, and a second sustain electrode 75 is disposed within the material layers 66, such that the first sustain electrode and the second sustain electrode are in a co-planar configuration. In another embodiment, as shown in Fig. 13, a first sustain electrode 70 is disposed on the first substrate 10, a first address electrode 80 is disposed within the material layers 66, and a second sustain electrode 75 is disposed within the material layers 66, such that the first address electrode is located between the first sustain electrode and the second sustain electrode in a mid-plane configuration. In this mid-plane configuration, the sustain function will be performed by the two sustain electrodes much like in the co-planar

configuration and the address function will be performed between at least one of the sustain electrodes and the address electrode. It is believed that energizing a micro-component with this arrangement of electrodes will produce increased luminosity. As seen in Fig. 14, in a preferred embodiment of the present invention, a first sustain electrode 70 is disposed on the first substrate 10, a first address electrode 80 is disposed within the material layers 66, a second address electrode 85 is disposed within the material layers 66, and a second sustain electrode 75 is disposed within the material layers 66, such that the first address electrode and the second address electrode are located between the first sustain electrode and the second sustain electrode. This configuration completely separates the addressing function from the sustain electrodes. It is believed that this arrangement will provide a simpler and cheaper means of addressing, sustain and erasing, because complicated switching means will not be required since different voltage sources may be used for the sustain and address electrodes. It is also believed that by separating the sustain and address electrodes so different voltage sources may be used to provide the address and sustain functions a lower or different type of voltage source may be used to provide the address or sustain functions.

Other embodiments and uses of the present invention will be apparent to those skilled in the art from consideration of this application and practice of the invention disclosed herein. The present description and examples should be considered exemplary only, with the true scope and spirit of the invention being indicated by the following claims. As will be understood by those of ordinary skill in the art, variations and modifications of each of the disclosed embodiments, including combinations thereof, can be made within the scope of this invention as defined by the following claims.

**CLAIMS**

What is claimed is:

- 1           1.     A light-emitting panel comprising:  
2           a first substrate;  
3           a second substrate opposed to the first substrate;  
4           a plurality of sockets, wherein each socket of the plurality of sockets comprises a cavity  
5           and wherein the cavity is patterned in the first substrate;  
6           a plurality of micro-components, wherein at least one micro-component of the plurality of  
7           micro-components is at least partially disposed in each socket; and  
8           at least two electrodes, wherein the at least two electrodes are adhered to the first  
9           substrate, the second substrate or any combination thereof, and wherein the at least two  
10          electrodes are arranged so that voltage supplied to the at least two electrodes causes one or more  
11          micro-components to emit radiation.
  
- 1           2.     The light-emitting panel of claim 1, wherein the at least two electrodes comprise  
2           one or more address electrodes and one or more sustain electrodes, and wherein at least one  
3           address electrode is traverse to at least one sustain electrode.
  
- 1           3.     The light-emitting panel of claim 1, wherein the at least two electrodes comprise  
2           one or more address electrodes and one or more sustain electrodes, and wherein at least one  
3           address electrode or at least one sustain electrode is at least partially disposed in the cavity.
  
- 1           4.     The light-emitting panel of claim 1, wherein each socket comprises at least one  
2           enhancement material, wherein the at least one enhancement material is disposed in or proximate  
3           to each socket, and wherein the at least one enhancement material is selected from a group  
4           consisting of transistors, integrated-circuits, semiconductor devices, inductors, capacitors,  
5           resistors, control electronics, drive electronics, diodes, pulse forming networks, pulse  
6           compressors, pulse transformers, and tuned-circuits.

1           5.       The light-emitting panel of claim 4, further comprising a controller, wherein the  
2 controller selectively controls the operation of at least one enhancement material to adjust at least  
3 one characteristic of the micro-component.

1           6.       A light-emitting panel comprising:  
2           a first substrate;  
3           a second substrate opposed to the first substrate;  
4           a plurality of sockets, wherein each socket of the plurality of sockets comprises a cavity  
5 and wherein the cavity is patterned in the first substrate;  
6           a plurality of micro-components, wherein at least one micro-component of the plurality of  
7 micro-components is at least partially disposed in each socket; and  
8           a plurality of electrodes, wherein at least two electrodes of the plurality of electrodes are  
9 arranged so that voltage supplied to the at least two electrodes causes one or more micro-  
10 components to emit radiation throughout the field of view of the light-emitting panel without  
11 crossing the at least two electrodes.

1           7.       The light-emitting panel of claim 6, wherein the at least two electrodes comprise  
2 one or more address electrodes and one or more sustain electrodes, and wherein at least one  
3 address electrode is traverse to at least one sustain electrode.

1           8.       The light-emitting panel of claim 6, wherein the at least two electrodes comprise  
2 one or more address electrodes and one or more sustain electrodes, and wherein at least one  
3 address electrode or at least one sustain electrode is at least partially disposed in the cavity.

1           9.       The light-emitting panel of claim 6, wherein each socket comprises at least one  
2 enhancement material, wherein the at least one enhancement material is disposed in or proximate  
3 to each socket, and wherein the at least one enhancement material is selected from a group  
4 consisting of transistors, integrated-circuits, semiconductor devices, inductors, capacitors,  
5 resistors, control electronics, drive electronics, diodes, pulse forming networks, pulse  
6 compressors, pulse transformers, and tuned-circuits.

1           10.    The light-emitting panel of claim 9, further comprising a controller, wherein the  
2 controller selectively controls the operation of at least one enhancement material to adjust at least  
3 one characteristic of the micro-component.

1           11.    A light-emitting panel comprising:  
2           a first substrate comprising a plurality of material layers;  
3           a second substrate opposed to the first substrate;  
4           a plurality of sockets, wherein each socket comprises a cavity and wherein the cavity is  
5 formed by selectively removing a portion of the material layers;  
6           a plurality of micro-components, wherein at least one micro-component of the plurality of  
7 micro-components is at least partially disposed in each socket; and  
8           a plurality of electrodes, wherein at least one electrode of the plurality of electrodes is  
9 disposed on or within the material layers.

1           12.    The light-emitting panel of claim 11, wherein each socket further comprises a first  
2 address electrode, a first sustain electrode and a second sustain electrode, such that the first  
3 sustain electrode and the second sustain electrode are disposed in a co-planar configuration.

1           13.    The light-emitting panel of claim 11, wherein each socket further comprises a first  
2 address electrode, a first sustain electrode and a second sustain electrode, such that the first  
3 address electrode is disposed in a mid-plane configuration.

1           14.    The light-emitting panel of claim 11, wherein each socket further comprises a first  
2 address electrode, a second address electrode, a first sustain electrode, and a second sustain  
3 electrode, such that the first address electrode and the second address electrode are disposed  
4 between the first sustain electrode and the second sustain electrode.

1           15.    The light-emitting panel of claim 11, wherein each socket comprises at least one  
2 enhancement material, wherein the at least one enhancement material is disposed in or proximate  
3 to each socket, and wherein the at least one enhancement material is selected from a group



4 consisting of transistors, integrated-circuits, semiconductor devices, inductors, capacitors,  
5 resistors, control electronics, drive electronics, diodes, pulse forming networks, pulse  
6 compressors, pulse transformers, and tuned-circuits.

1 16. The light-emitting panel of claim 15, further comprising a controller, wherein the  
2 controller selectively controls the operation of at least one enhancement material to adjust at least  
3 one characteristic of the micro-component.

1 17. A light-emitting panel comprising:  
2 a first substrate;  
3 a second substrate opposed to the first substrate;  
4 a plurality of sockets, wherein each socket of the plurality of sockets comprises  
5 a cavity, wherein the cavity is patterned in the first substrate, and  
6 a plurality of material layers, wherein the plurality of material layers are disposed  
7 on the first substrate such that the plurality of material layers conform to the shape of the cavity  
8 of each socket;  
9 a plurality of micro-components, wherein at least one micro-component of the plurality of  
10 micro-components is at least partially disposed in each socket; and  
11 a plurality of electrodes, wherein at least one electrode of the plurality of electrodes is  
12 disposed within the material layers.

1 18. The light-emitting panel of claim 17, wherein each socket further comprises a first  
2 address electrode, a first sustain electrode and a second sustain electrode, such that the first  
3 sustain electrode and the second sustain electrode are disposed in a co-planar configuration.

1 19. The light-emitting panel of claim 17, wherein each socket further comprises a first  
2 address electrode, a first sustain electrode and a second sustain electrode, such that the first  
3 address electrode is disposed in a mid-plane configuration.

1           20.    The light-emitting panel of claim 17, wherein each socket further comprises a first  
2 address electrode, a second address electrode, a first sustain electrode, and a second sustain  
3 electrode, such that the first address electrode and the second address electrode are disposed  
4 between the first sustain electrode and the second sustain electrode.

1           21.    The light-emitting panel of claim 17, wherein each socket comprises at least one  
2 enhancement material, wherein the at least one enhancement material is disposed in or proximate  
3 to each socket, and wherein the at least one enhancement material is selected from a group  
4 consisting of transistors, integrated-circuits, semiconductor devices, inductors, capacitors,  
5 resistors, control electronics, drive electronics, diodes, pulse forming networks, pulse  
6 compressors, pulse transformers, and tuned-circuits.

1           22.    The light-emitting panel of claim 21, further comprising a controller, wherein the  
2 controller selectively controls the operation of at least one enhancement material to adjust at least  
3 one characteristic of the micro-component.

1           23.    A method for energizing a micro-component in a light-emitting panel, comprising  
2 the steps of:  
3           providing a first substrate;  
4           patterning a cavity in the first substrate;  
5           disposing at least one electrode in or proximate to the cavity;  
6           at least partially disposing at least one micro-component in the cavity, such that the at  
7 least one micro-component is in electrical contact with the at least one electrode; and  
8           providing a voltage to at least two electrodes causing the at least one micro-component to  
9 emit radiation.

1           24.    A method for energizing a micro-component in a light-emitting panel, comprising  
2 the steps of:

3 forming a first substrate by disposing a plurality of material layers, wherein the step of  
4 disposing the plurality of material layers, comprises the step of disposing at least one electrode  
5 on or within the material layers;  
6 selectively removing a portion of the material layers to form a cavity;  
7 at least partially disposing at least one micro-components in the cavity, such that the at  
8 least one micro-component is in electrical contact with the at least one electrode; and  
9 providing a voltage to at least two electrodes causing the at least one micro-component to  
10 emit radiation.

1 25. The method of claim 24, wherein the step of disposing at least one electrode  
2 comprises the steps of:  
3 disposing a first address electrode between a first material layer and a second material  
4 layer; and  
5 disposing a first sustain electrode and a second sustain electrode between the second  
6 material layer and a third material layer.

1 26. The method of claim 24, wherein the step of disposing at least one electrode  
2 comprises the steps of:  
3 disposing a first sustain electrode between a first material layer and a second material  
4 layer;  
5 disposing a first address electrode between the second material layer and a third material  
6 layer; and  
7 disposing a second sustain electrode between the third material layer and a fourth material  
8 layer.

1 27. The method of claim 24, wherein the step of disposing at least one electrode  
2 comprises the steps of:  
3 disposing a first sustain electrode between a first material layer and a second material  
4 layer;

5 disposing a first address electrode between the second material layer and a third material  
6 layer;  
7 disposing a second address electrode between the third material layer and a fourth  
8 material layer; and  
9 disposing a second sustain electrode between the fourth material layer and a fifth material  
10 layer.

1 28. The method of claim 24, further comprising the step of disposing at least one  
2 enhancement material on or within the plurality of material layers and wherein the at least one  
3 enhancement material is selected from a group consisting of transistors, integrated-circuits,  
4 semiconductor devices, inductors, capacitors, resistors, control electronics, drive electronics,  
5 diodes, pulse forming networks, pulse compressors, pulse transformers, and tuned-circuits.

1 29. A method for energizing a micro-component in a light-emitting panel, comprising  
2 the steps of:  
3 providing a first substrate;  
4 patterning a cavity in the first substrate;  
5 disposing a plurality of material layers on the first substrate so that the plurality of  
6 material layers conform to the shape of the cavity, wherein the step of disposing the plurality of  
7 material layers, comprises the step of disposing at least one electrode on or within the material  
8 layers;  
9 at least partially disposing at least at least one micro-components in the cavity, such that  
10 the at least one micro-component is in electrical contact with the at least one electrode; and  
11 providing a voltage to at least two electrodes causing the at least one micro-component to  
12 emit radiation.

1 30. The method of claim 29, wherein the step of disposing at least one electrode  
2 comprises the steps of:  
3 disposing a first address electrode between the first substrate and a first material layer;  
4 and

5 disposing a first sustain electrode and a second sustain electrode between the first  
6 material layer and a second material layer.

1 31. The method of claim 29, wherein the step of disposing at least one electrode  
2 comprises the steps of:  
3 disposing a first sustain electrode between the first substrate and a first material layer;  
4 disposing a first address electrode between the first material layer and a second material  
5 layer; and  
6 disposing a second sustain electrode between the second material layer and a third  
7 material layer.

1 32. The method of claim 29, wherein the step of disposing at least one electrode  
2 comprises the steps of:  
3 disposing a first sustain electrode between the first substrate and a first material layer;  
4 disposing a first address electrode between the first material layer and a second material  
5 layer;  
6 disposing a second address electrode between the second material layer and a third  
7 material layer; and  
8 disposing a second sustain electrode between the third material layer and a fourth material  
9 layer.

1 33. The method of claim 29, further comprising the step of disposing at least one  
2 enhancement material on or within the plurality of material layers and wherein the at least one  
3 enhancement material is selected from a group consisting of transistors, integrated-circuits,  
4 semiconductor devices, inductors, capacitors, resistors, control electronics, drive electronics,  
5 diodes, pulse forming networks, pulse compressors, pulse transformers, and tuned-circuits.

1 34. A light-emitting panel comprising:  
2 a first substrate;

-28-

3 a plurality of material layers disposed on the first substrate, wherein each material layer of  
4 the plurality of material layers comprises an aperture;  
5 a second substrate opposed to the first substrate;  
6 a plurality of sockets, wherein each socket comprises a cavity and wherein the cavity is  
7 formed by aligning the apertures of the plurality of material layers;  
8 a plurality of micro-components, wherein at least one micro-component of the plurality of  
9 micro-components is at least partially disposed in each socket; and  
10 a plurality of electrodes, wherein at least one electrode of the plurality of electrodes is  
11 disposed on or within the material layers.

1 35. The light-emitting panel of claim 34, wherein each socket further comprises a first  
2 address electrode, a first sustain electrode and a second sustain electrode, such that the first  
3 sustain electrode and the second sustain electrode are disposed in a co-planar configuration.

1 36. The light-emitting panel of claim 34, wherein each socket further comprises a first  
2 address electrode, a first sustain electrode and a second sustain electrode, such that the first  
3 address electrode is disposed in a mid-plane configuration.

1 37. The light-emitting panel of claim 34, wherein each socket further comprises a first  
2 address electrode, a second address electrode, a first sustain electrode, and a second sustain  
3 electrode, such that the first address electrode and the second address electrode are disposed  
4 between the first sustain electrode and the second sustain electrode.

1 38. The light-emitting panel of claim 34, wherein each socket comprises at least one  
2 enhancement material, wherein the at least one enhancement material is disposed in or proximate  
3 to each socket, and wherein the at least one enhancement material is selected from a group  
4 consisting of transistors, integrated-circuits, semiconductor devices, inductors, capacitors,  
5 resistors, control electronics, drive electronics, diodes, pulse forming networks, pulse  
6 compressors, pulse transformers, and tuned-circuits.

1           39.    The light-emitting panel of claim 35, further comprising a controller, wherein the  
2 controller selectively controls the operation of at least one enhancement material to adjust at least  
3 one characteristic of the micro-component.

1           40.    A method for energizing a micro-component in a light-emitting panel, comprising  
2 the steps of:  
3           providing a first substrate;  
4           disposing a plurality of material layers on the first substrate, wherein each material layer  
5 of the plurality of material layers comprises an aperture, and wherein the step of disposing the  
6 plurality of material layers comprises the steps of  
7           aligning the apertures of each material layer so that when the plurality of material  
8 layers are disposed on the first substrate the apertures form a cavity, and  
9           disposing at least one electrode on or within the material layers;  
10          at least partially disposing at least one micro-component in the cavity, such that the at  
11 least one micro-component is in electrical contact with the at least one electrode; and  
12          providing a voltage to at least two electrodes causing the at least one micro-component to  
13 emit radiation.

1           41.    The method of claim 40, wherein the step of disposing at least one electrode  
2 comprises the steps of:  
3           disposing a first address electrode between a first material layer and a second material  
4 layer; and  
5           disposing a first sustain electrode and a second sustain electrode between the second  
6 material layer and a third material layer.

1           42.    The method of claim 40, wherein the step of disposing at least one electrode  
2 comprises the steps of:  
3           disposing a first sustain electrode between a first material layer and a second material  
4 layer;

5 disposing a first address electrode between the second material layer and a third material  
6 layer; and  
7 disposing a second sustain electrode between the third material layer and a fourth material  
8 layer.

1 43. The method of claim 40, wherein the step of disposing at least one electrode  
2 comprises the steps of:  
3 disposing a first sustain electrode between a first material layer and a second material  
4 layer;  
5 disposing a first address electrode between the second material layer and a third material  
6 layer;  
7 disposing a second address electrode between the third material layer and a fourth  
8 material layer; and  
9 disposing a second sustain electrode between the fourth material layer and a fifth material  
10 layer.

1 44. The method of claim 40, further comprising the step of disposing at least one  
2 enhancement material on or within the plurality of material layers and wherein the at least one  
3 enhancement material is selected from a group consisting of transistors, integrated-circuits,  
4 semiconductor devices, inductors, capacitors, resistors, control electronics, drive electronics,  
5 diodes, pulse forming networks, pulse compressors, pulse transformers, and tuned-circuits.



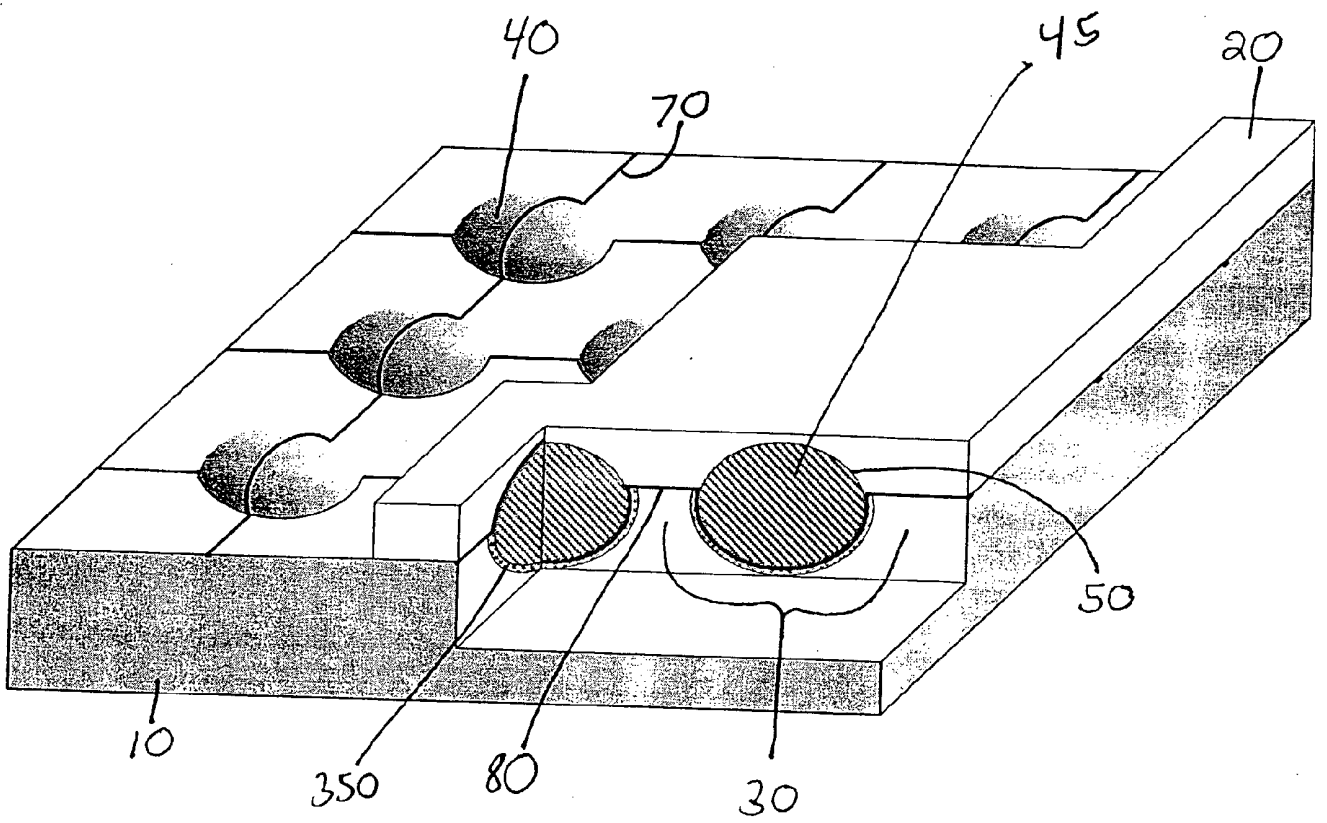

Fig. 1

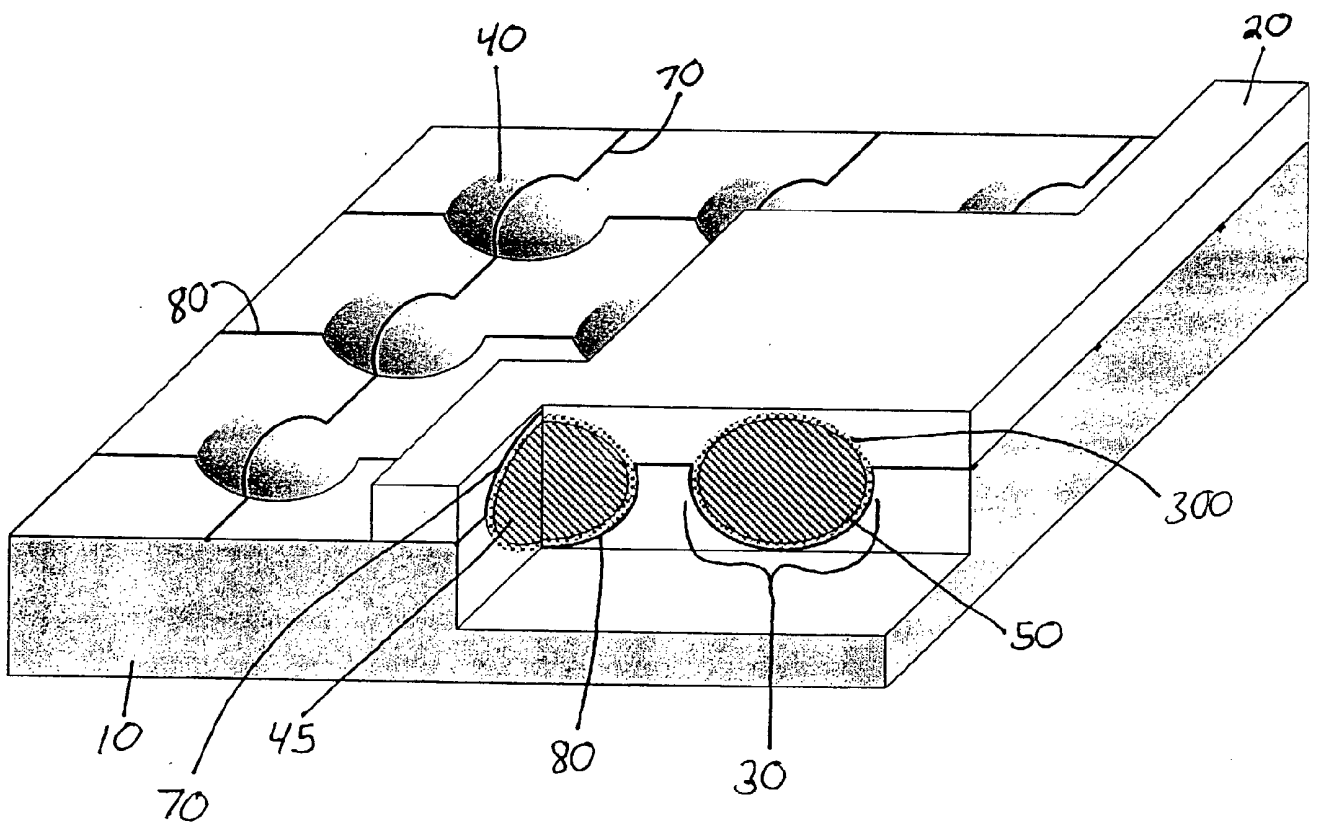

Fig. 2

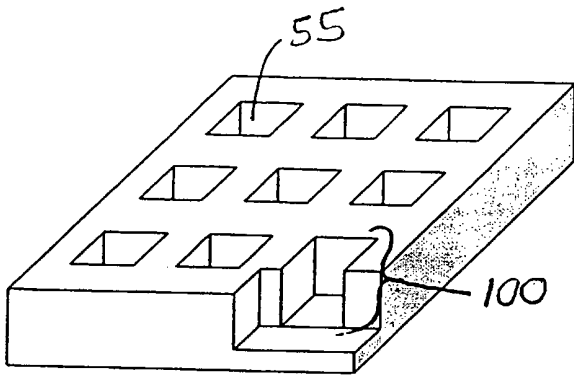

Fig. 3A

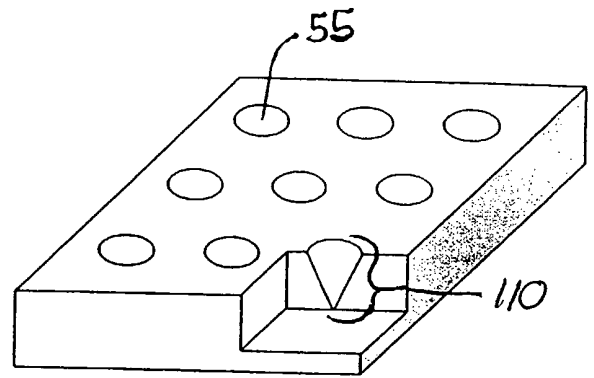

Fig. 3B

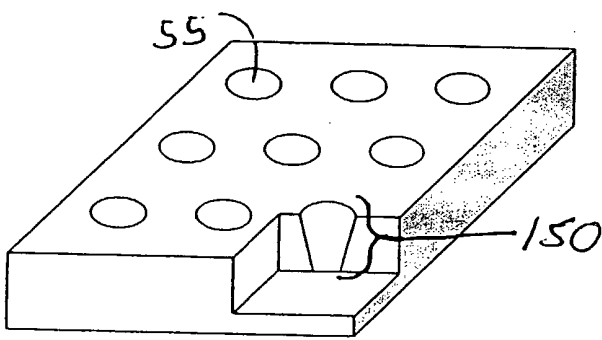

Fig. 3C

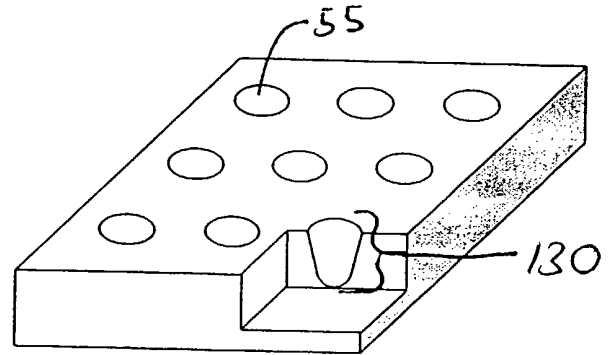

Fig. 3D

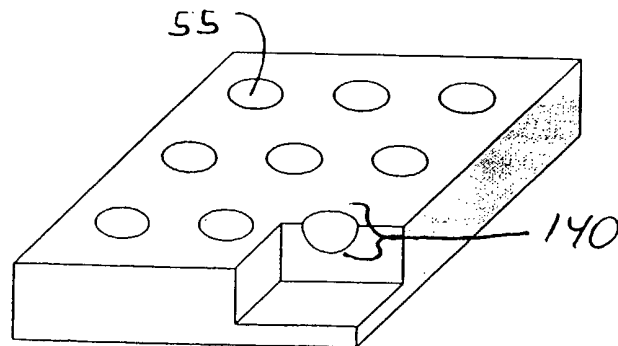

Fig. 3E

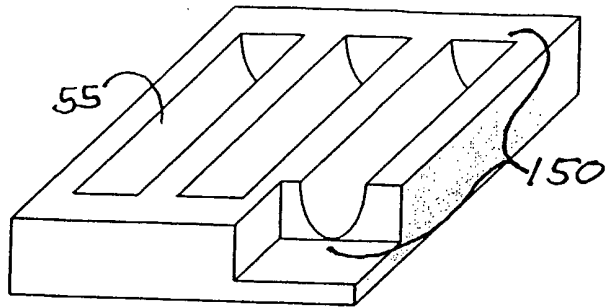

Fig. 3F

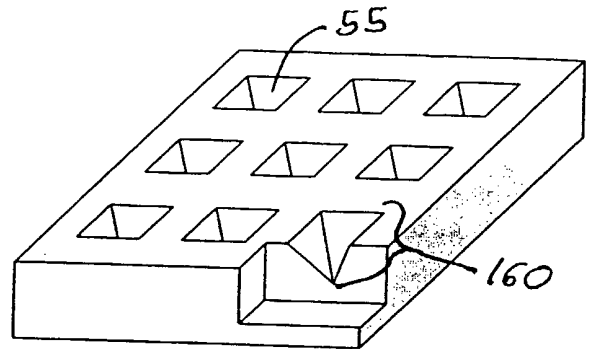

Fig. 3G

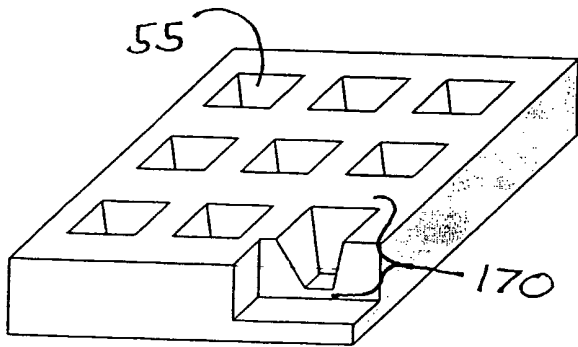

Fig. 3H

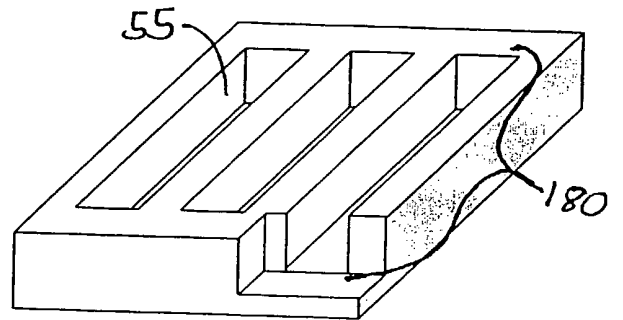

Fig. 3I

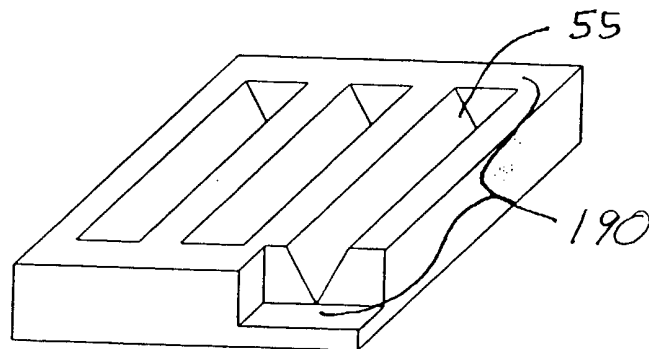

Fig. 3J

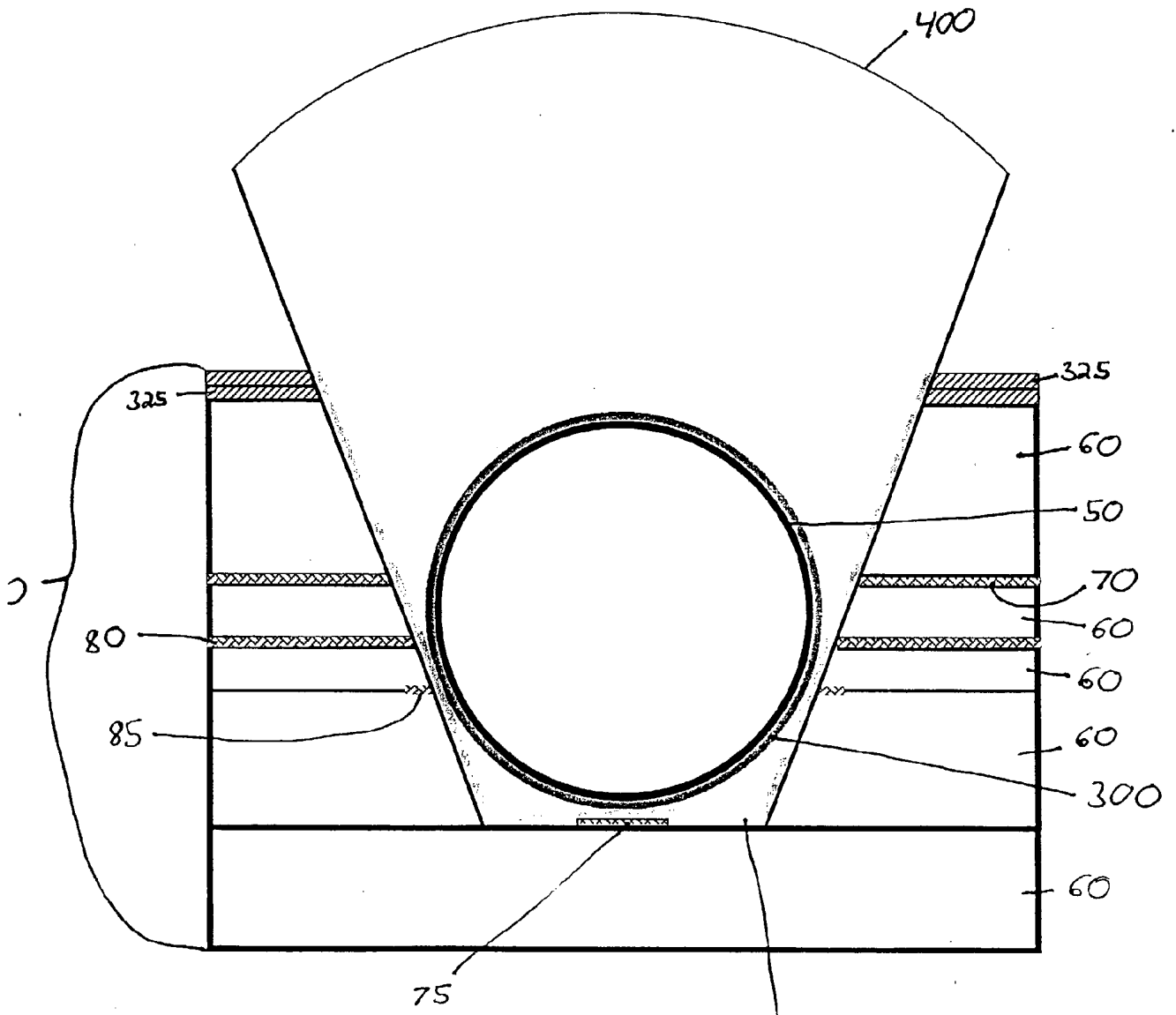

Fig. 4

350

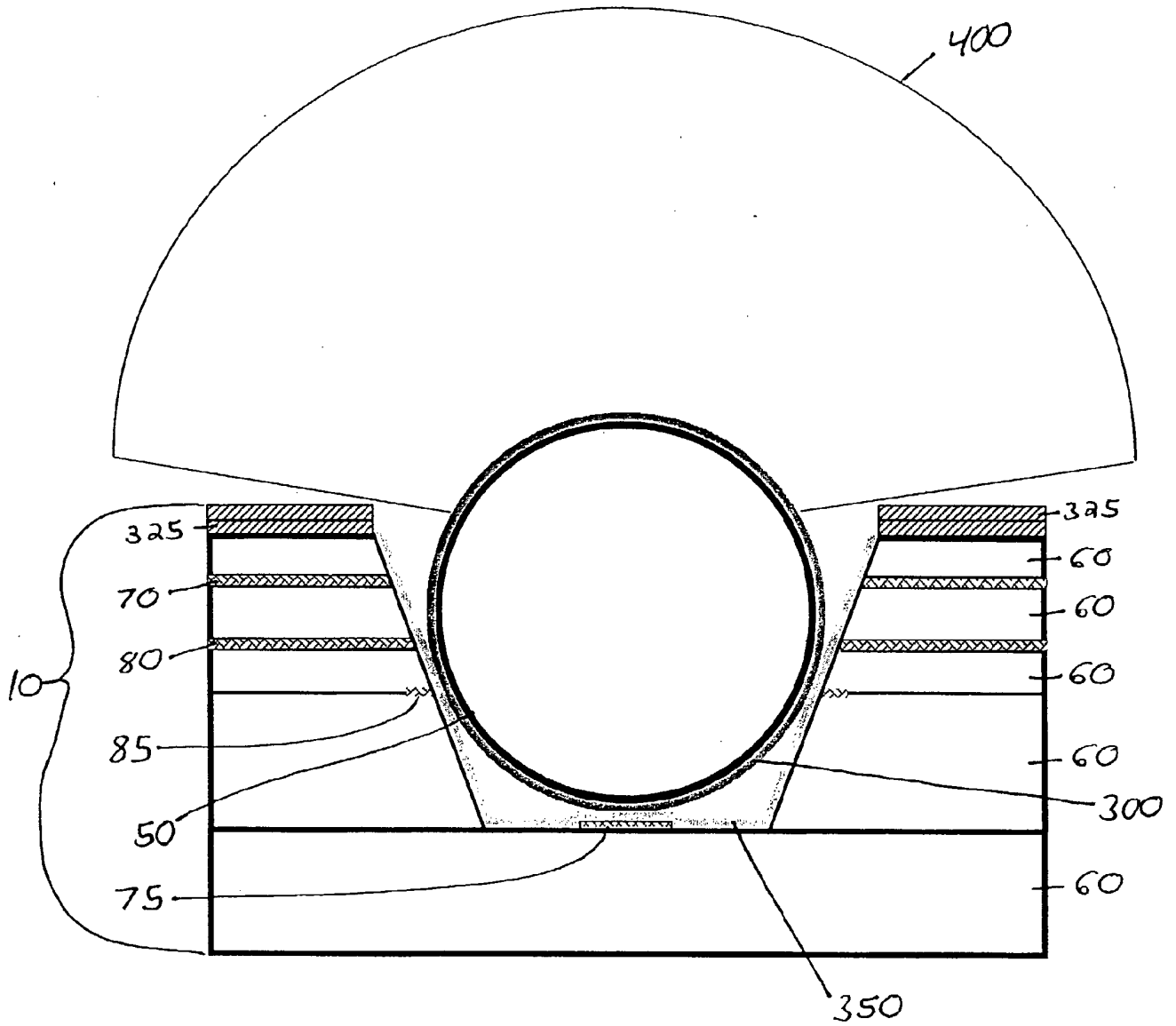

Fig. 5.

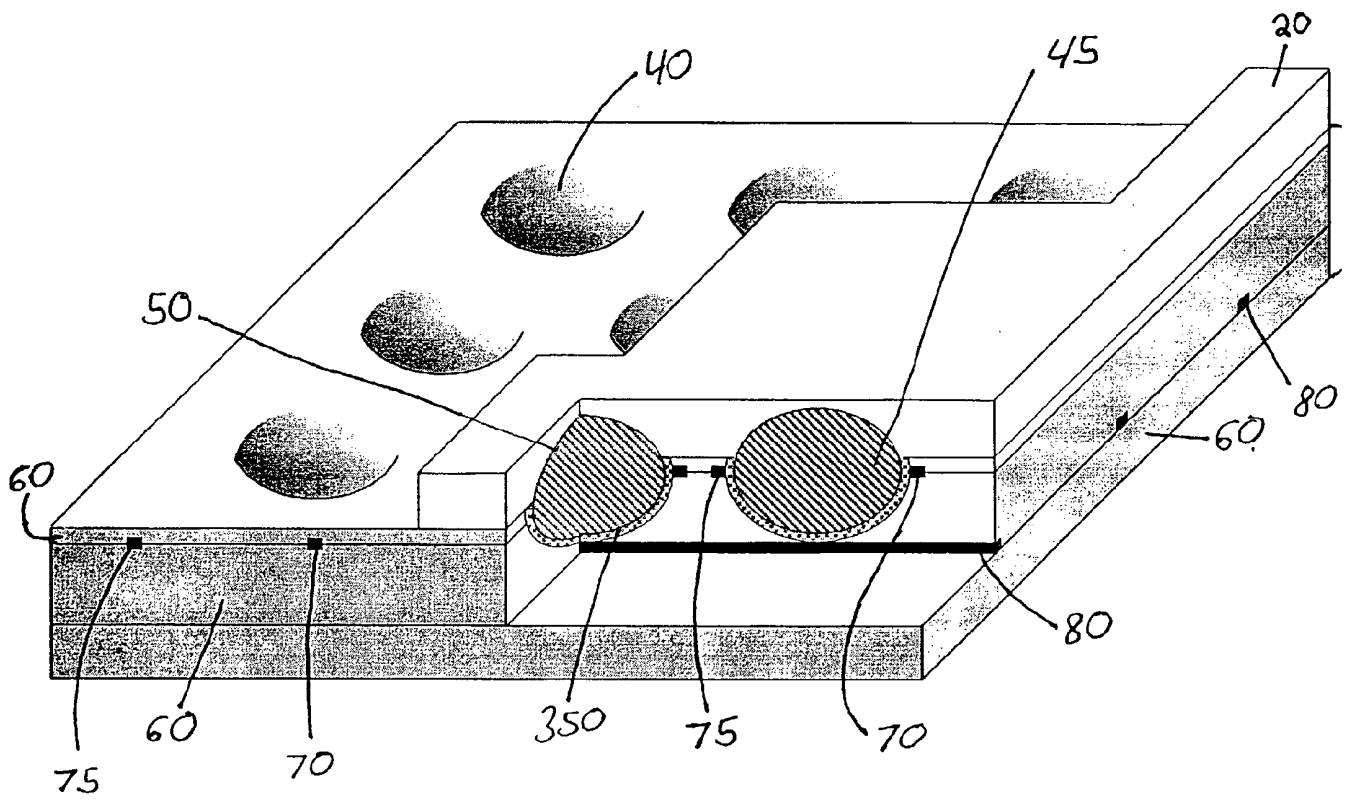
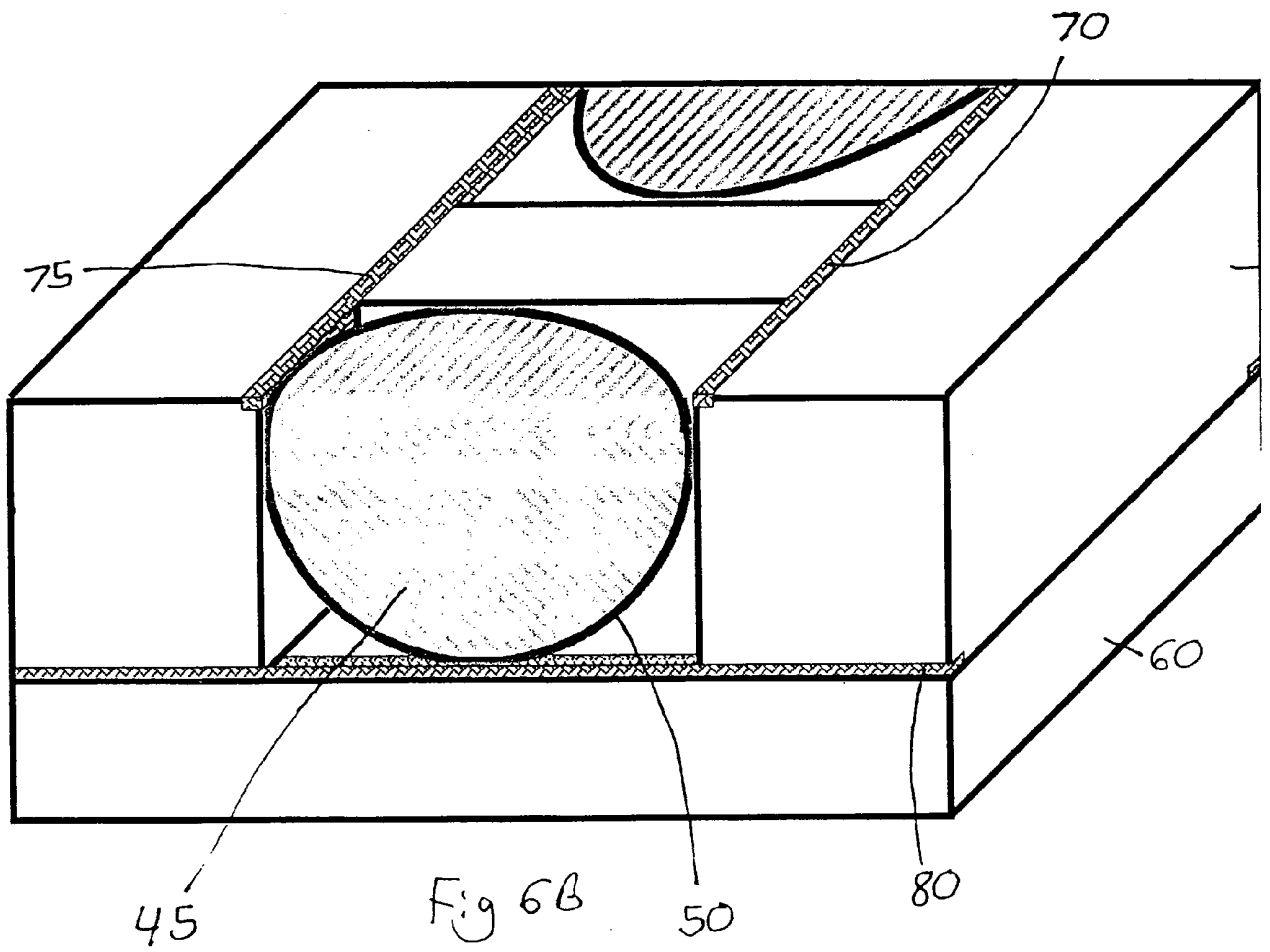

Fig. 6A





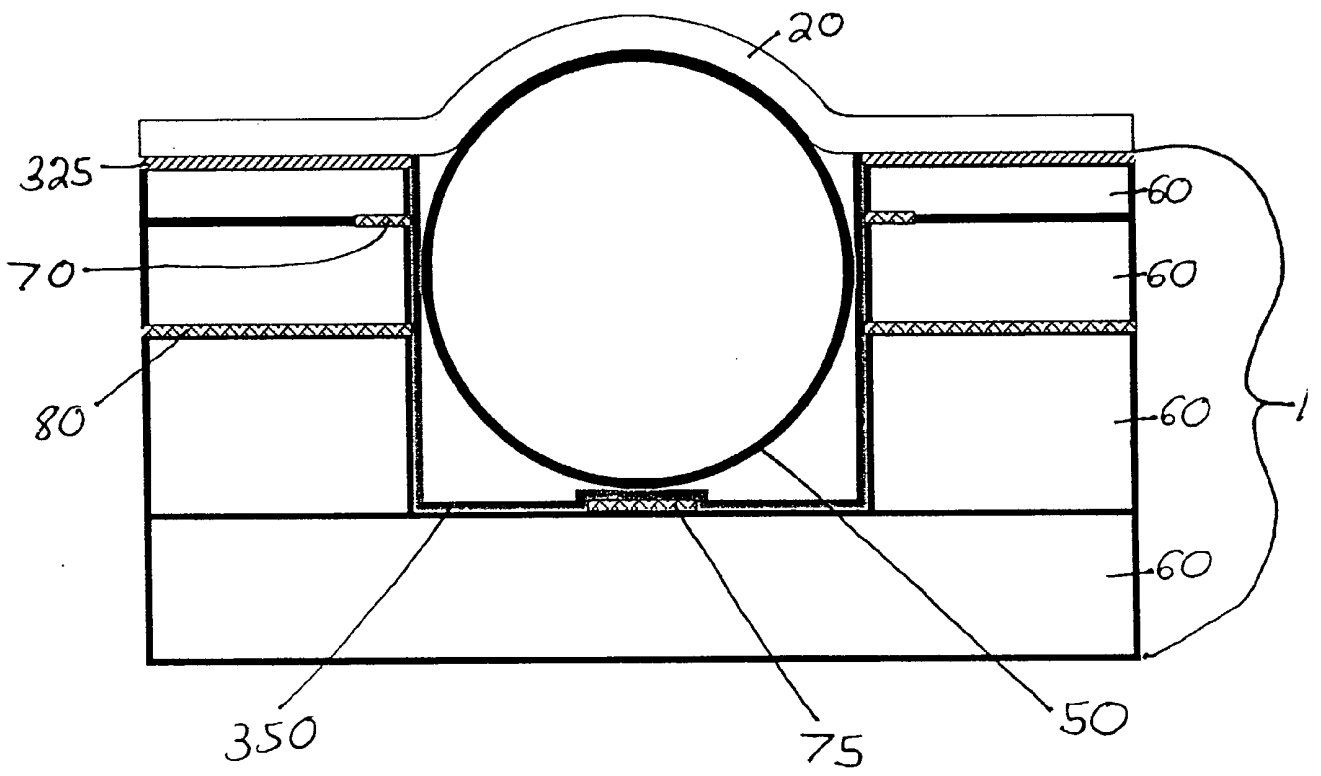

Fig. 7A

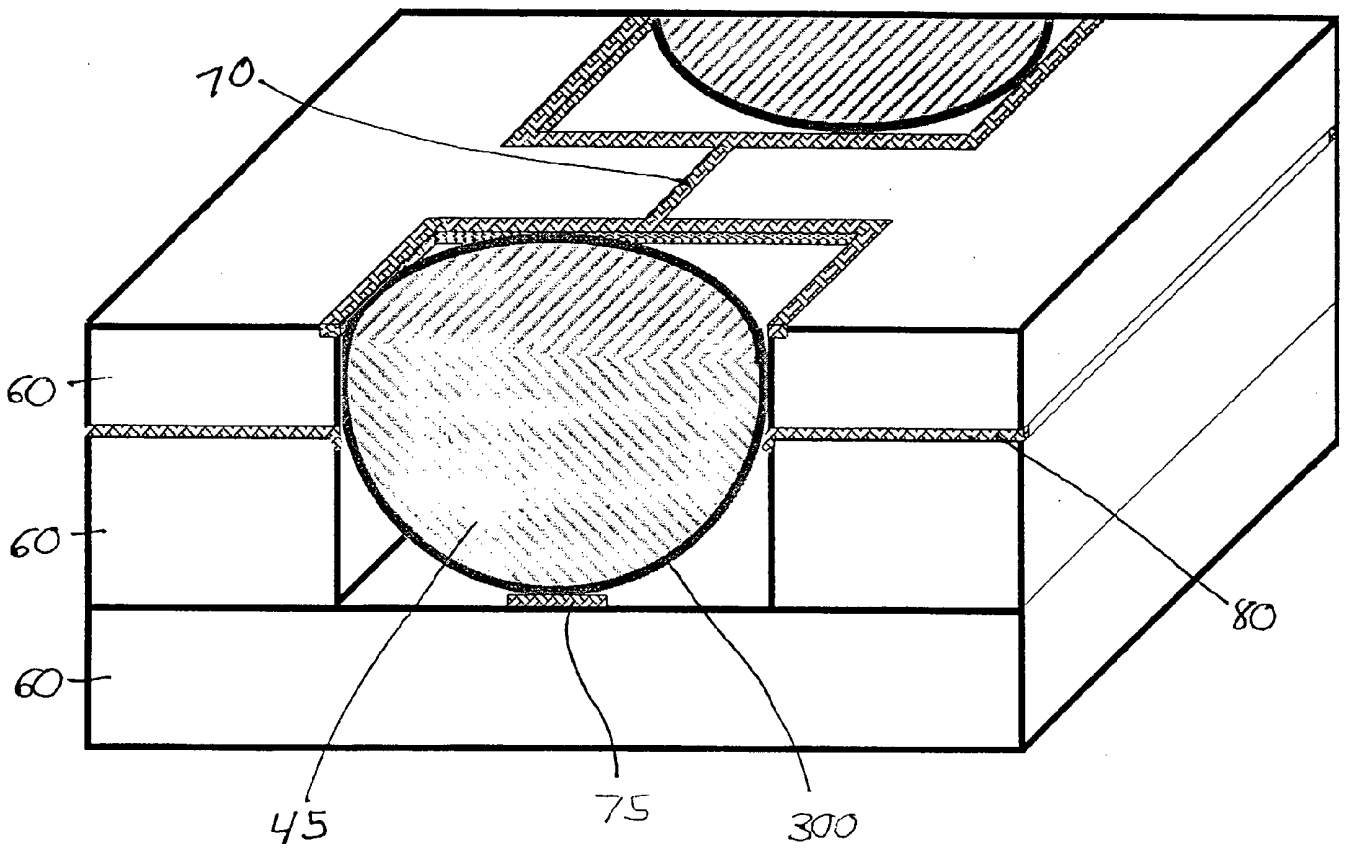

Fig. 7B

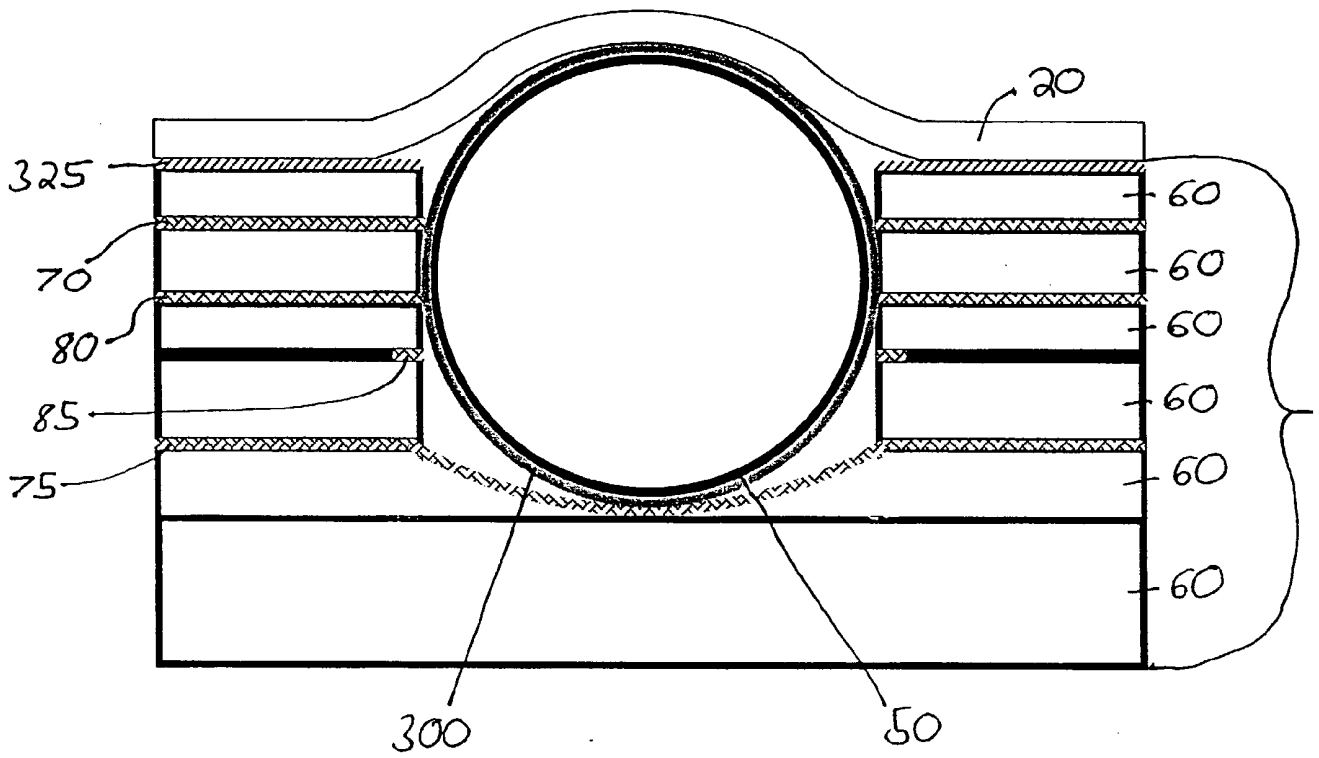

Fig. 8

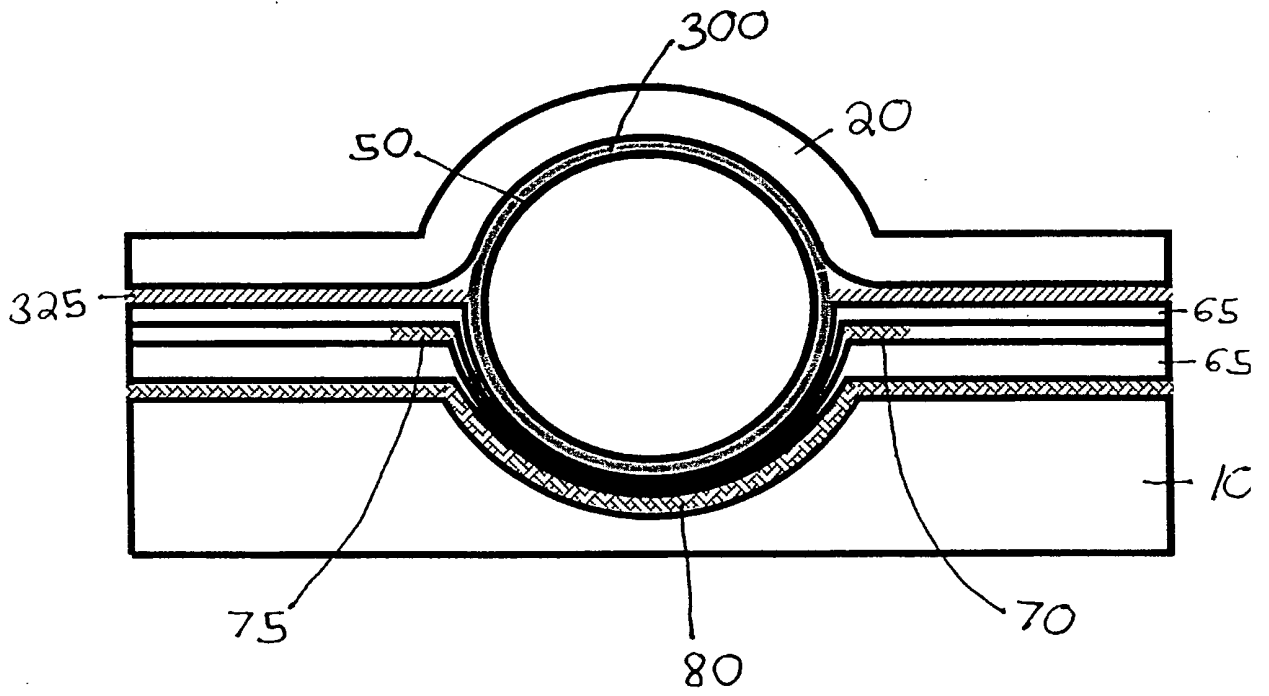

Fig. 9

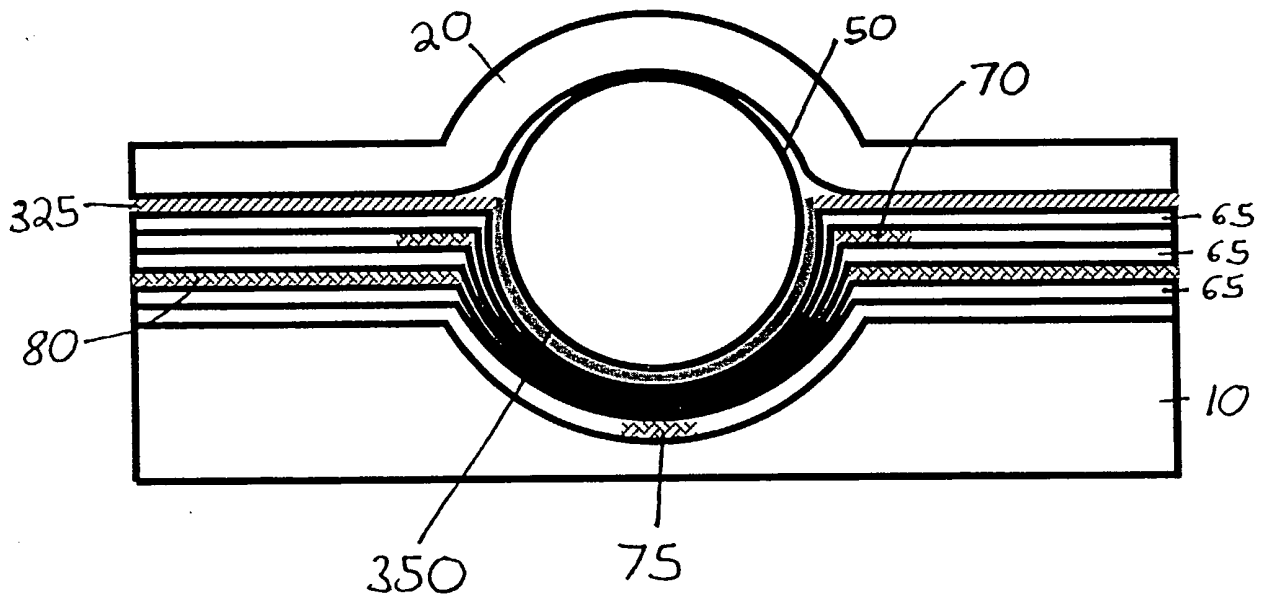

Fig. 10

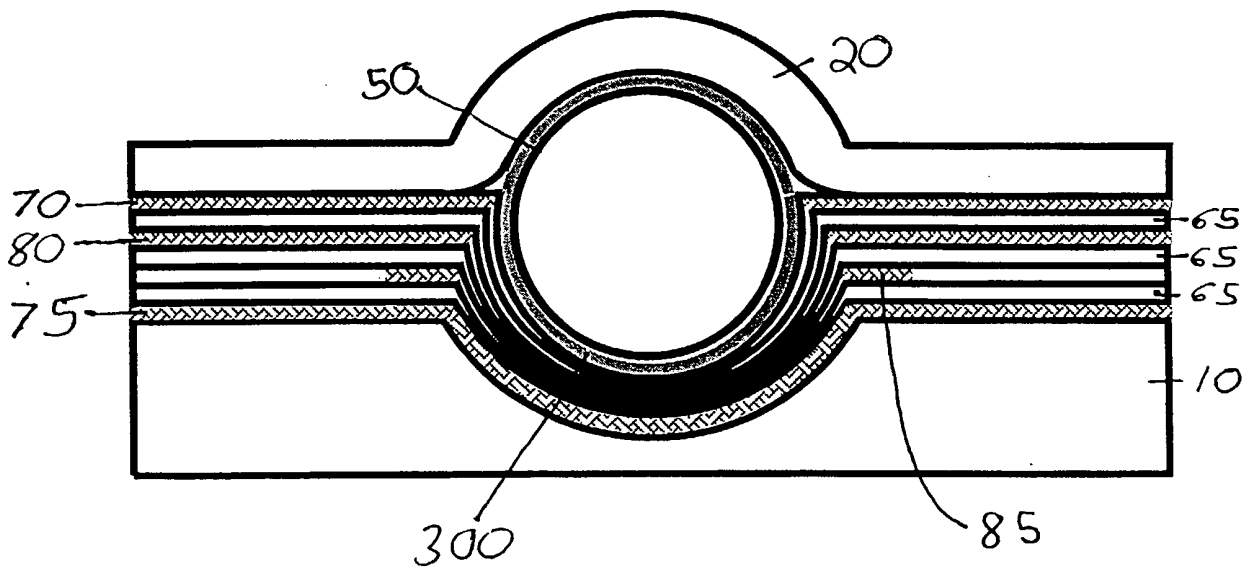

Fig. 11

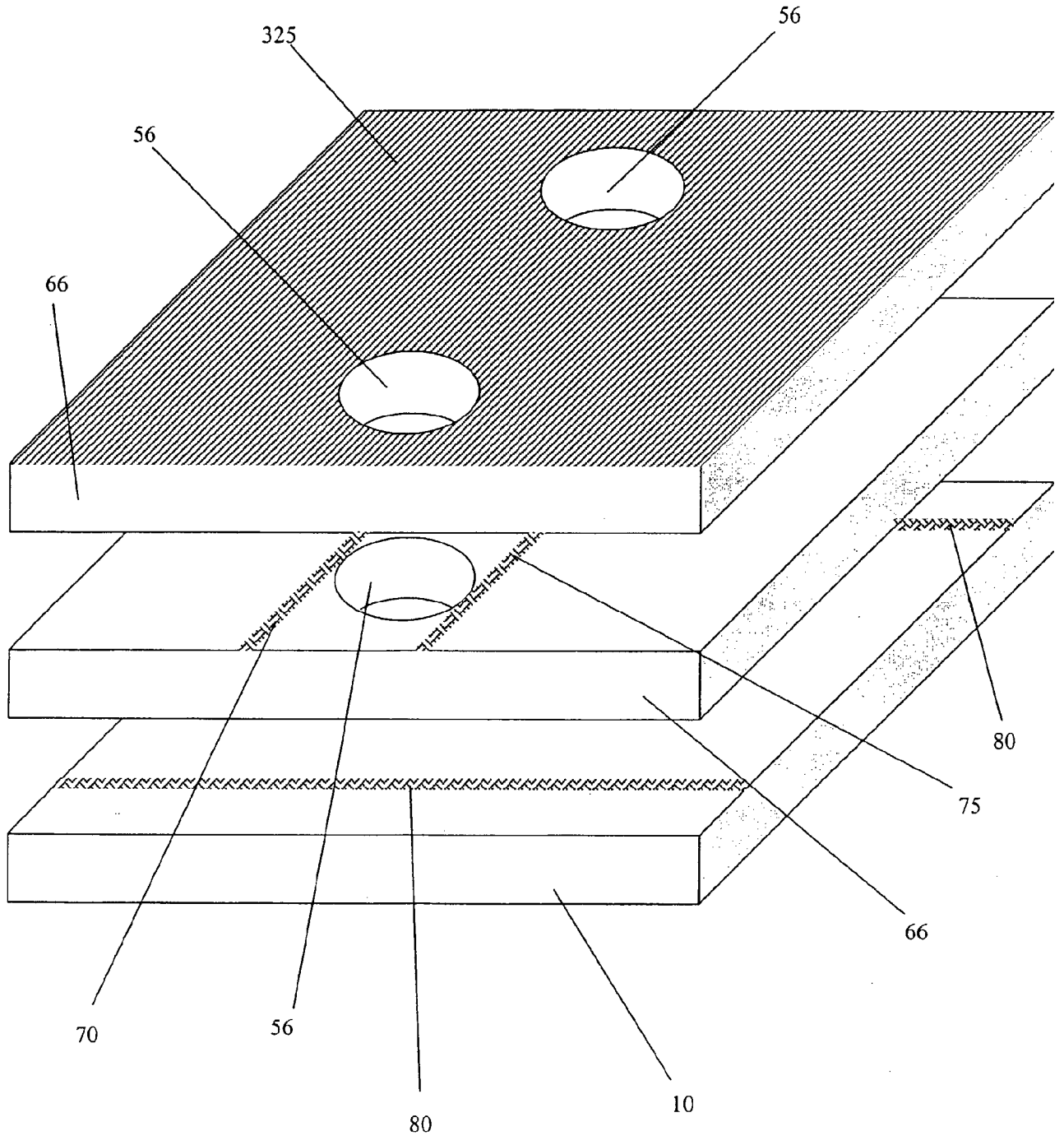

Fig. 12

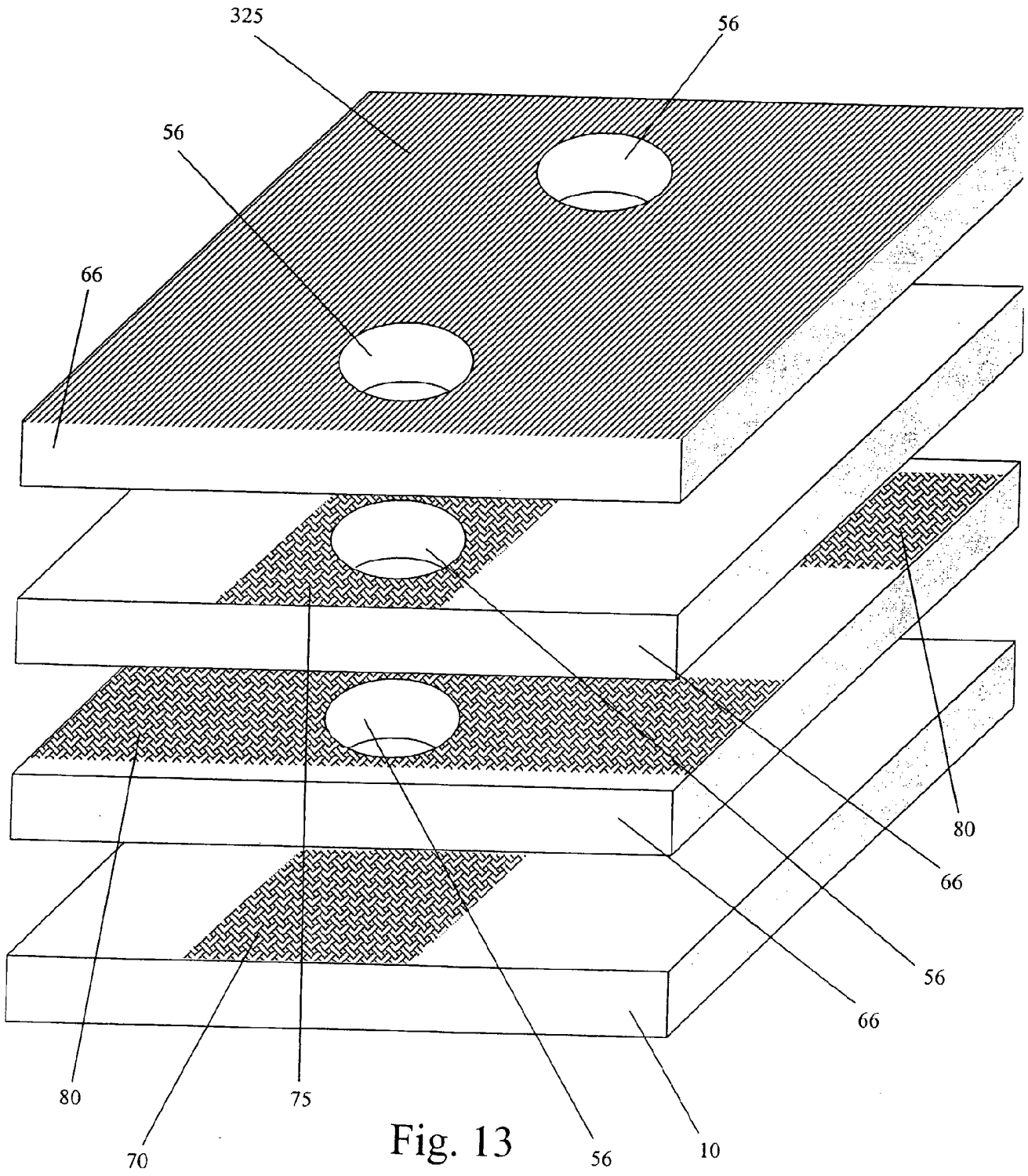

Fig. 13



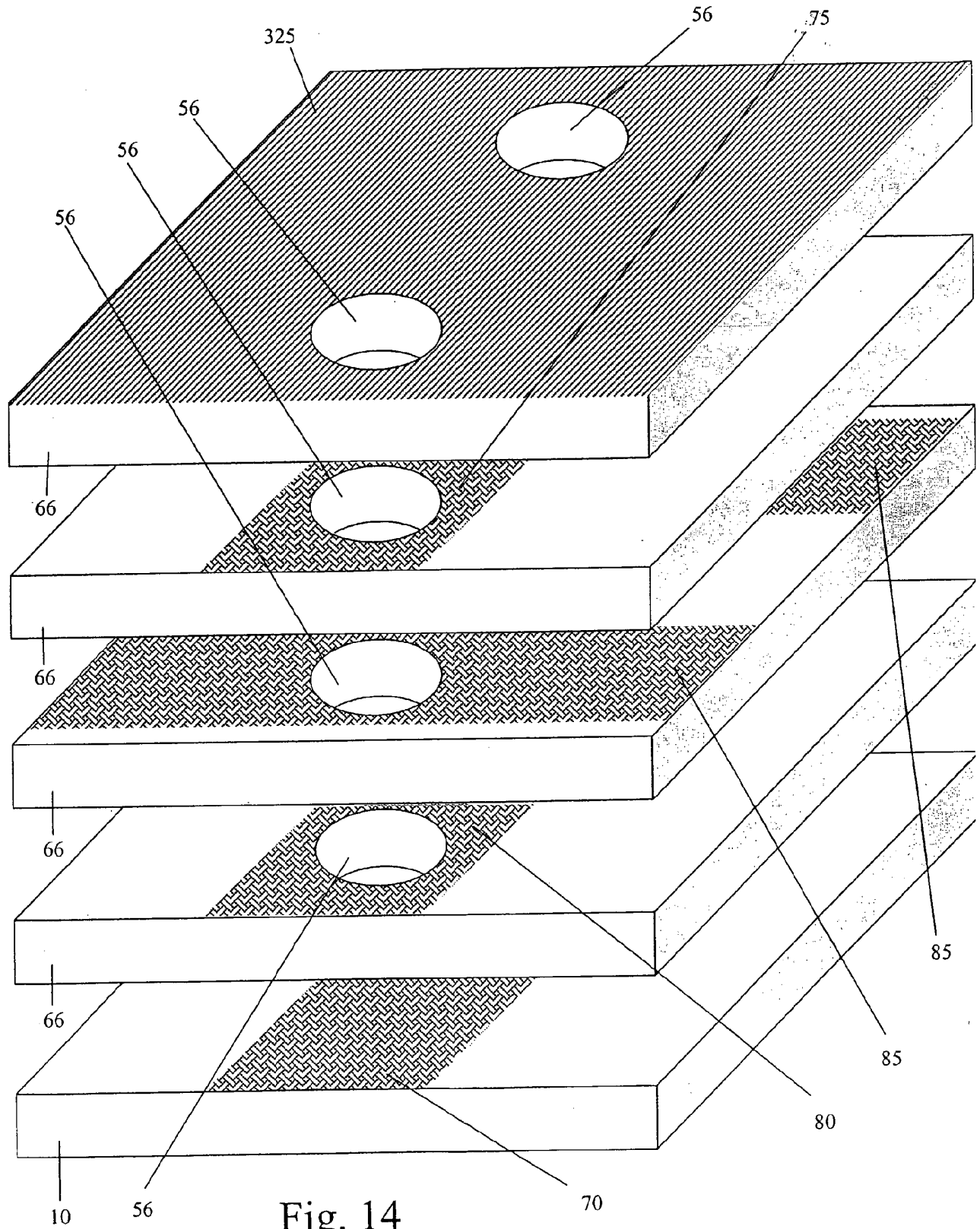

Fig. 14

INTERNATIONAL SEARCH REPORT

International application No.  
PCT/US01/42807

A. CLASSIFICATION OF SUBJECT MATTER

IPC(7) :G09G 3/10; H01G 1/00  
US CL :Please See Extra Sheet.

According to International Patent Classification (IPC) or to both national classification and IPC

B. FIELDS SEARCHED

Minimum documentation searched (classification system followed by classification symbols)

U.S. : 315/169.3, 312, 324; 313/484, 485, 491, 502, 506; 445/24, 26, 27, 29, 33

Documentation searched other than minimum documentation to the extent that such documents are included in the fields searched  
none

Electronic data base consulted during the international search (name of data base and, where practicable, search terms used)

EAST text search: light emitting panel, substrates or films or layers, cavity, socket, electrodes, sustain, address

C. DOCUMENTS CONSIDERED TO BE RELEVANT

Category*	Citation of document, with indication, where appropriate, of the relevant passages	Relevant to claim No.
X	US 4,563,617 A (DAVIDSON) 07 January 1986, (07/01/86) see figures 1-4; col. 5, lines 38-66; col. 11, lines 56-67.	1-24, 28-29, 33-40, 44
A	US 6,130,655 A (LAMMERS) 10 October 2000, (10/10/00) see entire document.	1-44

Further documents are listed in the continuation of Box C.  See patent family annex.

*	Special categories of cited documents:	"T"	later document published after the international filing date or priority date and not in conflict with the application but cited to understand the principle or theory underlying the invention
"A"	document defining the general state of the art which is not considered to be of particular relevance	"X"	document of particular relevance; the claimed invention cannot be considered novel or cannot be considered to involve an inventive step when the document is taken alone
"E"	earlier document published on or after the international filing date	"Y"	document of particular relevance; the claimed invention cannot be considered to involve an inventive step when the document is combined with one or more other such documents, such combination being obvious to a person skilled in the art
"L"	document which may throw doubts on priority claim(s) or which is cited to establish the publication date of another citation or other special reason (as specified)	"Z"	document member of the same patent family
"O"	document referring to an oral disclosure, use, exhibition or other means		
"P"	document published prior to the international filing date but later than the priority date claimed		

Date of the actual completion of the international search 01 MAY 2002	Date of mailing of the international search report 20 MAY 2002
--	---

Name and mailing address of the ISA/US  
Commissioner of Patents and Trademarks  
Box PCT  
Washington, D.C. 20231  
Facsimile No. (703) 305-3230

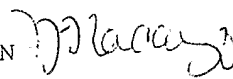
Authorized officer  
THUY VINH TRAN   
Telephone No. (703) 308-4856

# INTERNATIONAL SEARCH REPORT

International application No.

PCT/US01/42807

## A. CLASSIFICATION OF SUBJECT MATTER:

US CL :

315/169.3, 312, 324; 313/484, 485, 491, 502, 506; 445/24, 26, 27, 29, 33

## BOX I. OBSERVATIONS WHERE CLAIMS WERE FOUND UNSEARCHABLE

2. Where no meaningful search could be carried out, specifically:

The controller claimed in the claims 5, 16, 22, and 39 is neither described in the specification nor the drawings of the claimed invention. Such a missing description may cause misunderstandings about the configuration of the device with respect to the other devices/components and its functions as well.

# INTERNATIONAL SEARCH REPORT

International application No.

PCT/US01/42807

## Box I Observations where certain claims were found unsearchable (Continuation of item 1 of first sheet)

This international report has not been established in respect of certain claims under Article 17(2)(a) for the following reasons:

1.  Claims Nos.:  
because they relate to subject matter not required to be searched by this Authority, namely:
  
2.  Claims Nos.: 5, 16, 22, and 39  
because they relate to parts of the international application that do not comply with the prescribed requirements to such an extent that no meaningful international search can be carried out, specifically:  
  
Please See Extra Sheet.
  
3.  Claims Nos.:  
because they are dependent claims and are not drafted in accordance with the second and third sentences of Rule 6.1(a).

## Box II Observations where unity of invention is lacking (Continuation of item 2 of first sheet)

This International Searching Authority found multiple inventions in this international application, as follows:

1.  As all required additional search fees were timely paid by the applicant, this international search report covers all searchable claims.
2.  As all searchable claims could be searched without effort justifying an additional fee, this Authority did not invite payment of any additional fee.
3.  As only some of the required additional search fees were timely paid by the applicant, this international search report covers only those claims for which fees were paid, specifically claims Nos.:
  
4.  No required additional search fees were timely paid by the applicant. Consequently, this international search report is restricted to the invention first mentioned in the claims; it is covered by claims Nos.:

Remark on Protest

The additional search fees were accompanied by the applicant's protest.

No protest accompanied the payment of additional search fees.