

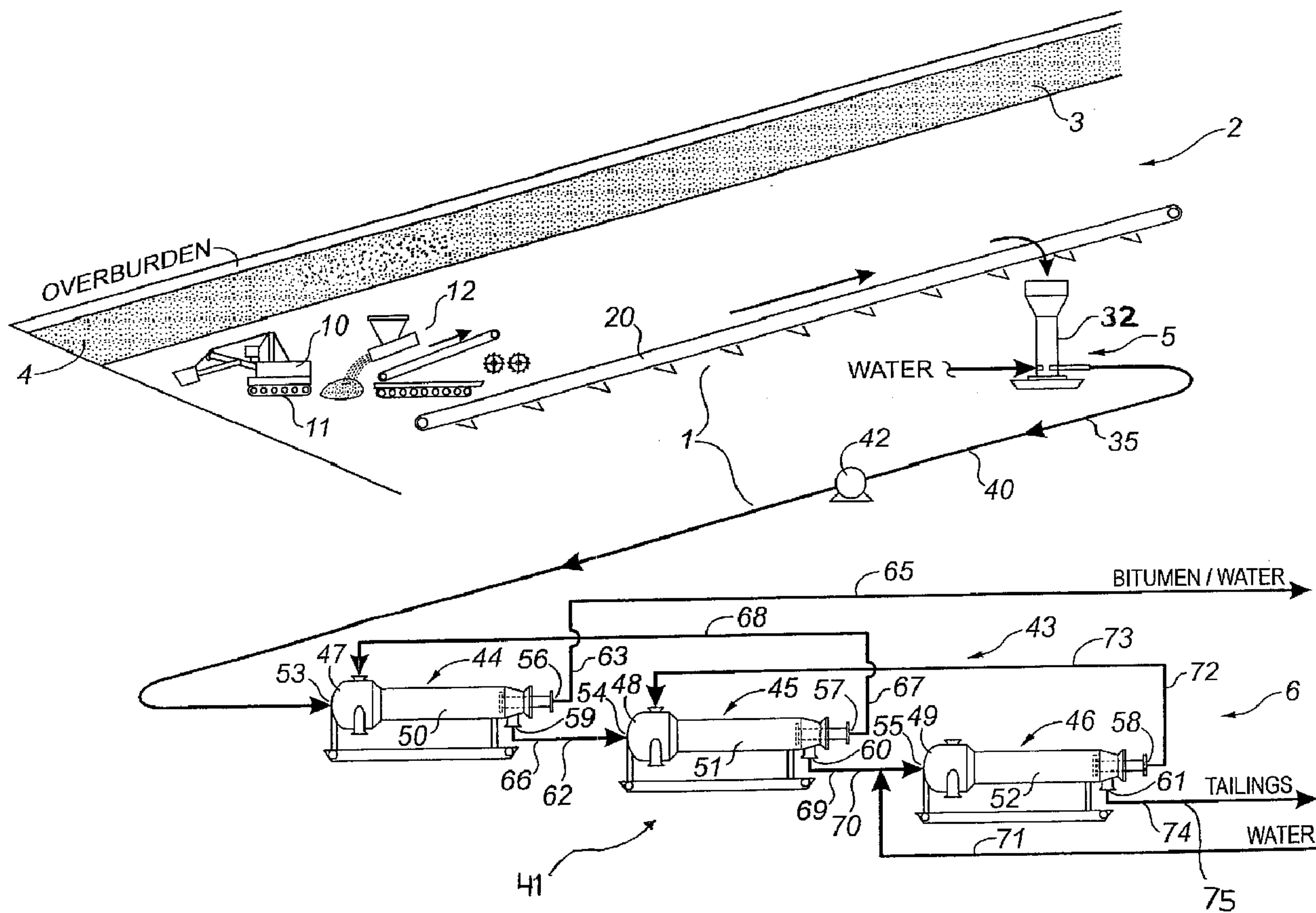

(22) Date de dépôt/Filing Date: 2003/12/18  
(41) Mise à la disp. pub./Open to Public Insp.: 2005/06/18  
(45) Date de délivrance/Issue Date: 2008/04/08

(51) Cl.Int./Int.Cl. *E21C 41/26* (2006.01),  
*E02F 7/00* (2006.01)  
(72) Inventeurs/Inventors:  
CYMERMAN, GEORGE, CA;  
COWARD, JULIAN, CA;  
MCTURK, JIM, CA  
(73) Propriétaires/Owners:  
CANADIAN OIL SANDS LIMITED, CA;  
CANADIAN OIL SANDS LIMITED PARTNERSHIP, CA;  
...  
(74) Agent: BENNETT JONES LLP

(54) Titre : TRAITEMENT DE SABLES PETROLIFERES SUR PLACE  
(54) Title: AT THE MINE SITE OIL SANDS PROCESSING



(57) Abrégé/Abstract:

A process line comprising a combination of mobile and relocatable equipment units is provided at an oil sand mine site. The process line may comprise: a mobile shovel; a mobile bin and double roll crusher; a relocatable conveyor belt extending along the

(73) **Propriétaires(suite)/Owners(continued):**PETRO-CANADA OIL AND GAS, CA; MURPHY OIL COMPANY LTD., CA; NEXEN INC., CA; MOCAL ENERGY LIMITED, JP; IMPERIAL OIL RESOURCES, CA; CONOCOPHILLIPS OILSANDS PARTNERSHIP II, CA

(57) **Abrégé(suite)/Abstract(continued):**

mine face; a relocatable slurry preparation assembly, such as a secondary crusher and jet pump; a pipeline; and a relocatable desanding circuit of separators. The process line conducts the following steps: mining the oil sand; crushing it to conveyable size; conveying it to a slurry preparation location; further crushing it to slurring size and mixing it with heated water to produce a pumpable, aerated oil sand slurry; transporting and conditioning the slurry in the pipeline; desanding it to produce a product comprising bitumen and water and tailings; depositing tailings in a retention facility; and removing the product from the mine site in a pipeline.

**"AT THE MINE SITE OIL SANDS PROCESSING"****ABSTRACT OF THE DISCLOSURE**

1  
2  
3 A process line comprising a combination of mobile and relocatable  
4 equipment units is provided at an oil sand mine site. The process line may  
5 comprise: a mobile shovel; a mobile bin and double roll crusher; a relocatable  
6 conveyor belt extending along the mine face; a relocatable slurry preparation  
7 assembly, such as a secondary crusher and jet pump; a pipeline; and a  
8 relocatable desanding circuit of separators. The process line conducts the  
9 following steps: mining the oil sand; crushing it to conveyable size; conveying  
10 it to a slurry preparation location; further crushing it to slurring size and  
11 mixing it with heated water to produce a pumpable, aerated oil sand slurry;  
12 transporting and conditioning the slurry in the pipeline; desanding it to  
13 produce a product comprising bitumen and water and tailings; depositing  
14 tailings in a retention facility; and removing the product from the mine site in a  
15 pipeline.

1                   **"AT THE MINE SITE OIL SANDS PROCESSING"**

2                   **FIELD OF THE INVENTION**

3                   The present invention relates to a system, located at a mine site, for  
4 mining oil sand, slurring it and desanding the slurry to produce a pipelineable  
5 stream of bitumen, fines and water.

6  
7                   **BACKGROUND OF THE INVENTION**

8                   Oil sand from the Fort McMurray region of Alberta has now been  
9 commercially surface mined and processed for about 40 years, to extract and  
10 recover the contained bitumen.

11                  The initial technique used can broadly be described as follows:

- 12                  • excavating oil sand;
- 13                  • crushing the as-mined oil sand, which contains large lumps and  
14 rocks, in stages, to a size which can be slurried and pumped;
- 15                  • mixing the crushed oil sand with heated water and, optionally,  
16 caustic or other process aids, to produce a slurry. In the course of  
17 mixing and subsequent pipelining, lumps are ablated, bitumen is  
18 liberated from the oil sand and is dispersed into the water phase, air  
19 bubbles are entrained and bitumen droplets coalesce and are  
20 aerated (the sum of these results is referred to as 'conditioning');
- 21                  • temporarily retaining the conditioned slurry under quiescent  
22 conditions in a large gravity separation vessel (referred to as the  
23 'PSV') – during this separation or flotation step, the sand settles and  
24 is removed as an underflow, together with some bitumen and water,



1 and the aerated bitumen, contaminated with water and solids,  
2 including fines, rises and is recovered as a froth;

3 • optionally, withdrawing watery middlings from the PSV and treating  
4 the middlings in induced air flotation cells to recover contained  
5 bitumen as a contaminated froth while rejecting water and solids as  
6 an underflow;

7 • processing the PSV underflow to recover contained bitumen as  
8 froth while rejecting water and solids (together with small amounts of  
9 contained residual bitumen) as an underflow;

10 • discarding the various water and solids underflows as tailings into  
11 retention areas; and

12 • combining and cleaning the froth streams in means such as  
13 centrifuges to remove residual water and solids and produce  
14 relatively clean bitumen ready for upgrading.

15 In selecting and developing the detailed steps, conditions and  
16 equipment units that embody this broadly described system, it needs to be  
17 appreciated that many factors have an influence in arriving at the final  
18 implementation. Some of these factors are:

19 • The oil sand is erosive and tacky and the throughput of oil sand is  
20 large. A typical circuit or process line, involving process steps and  
21 equipment units, might process 8000 tonnes of oil sand per hour.  
22 So the equipment used needs to facilitate processing this scale of  
23 throughput of erosive, tacky material;

- 1           • The oil sand contains clays that affect processing detrimentally and  
2           the composition of the oil sand varies on an on-going basis,  
3           particularly with respect to bitumen and clay contents. It is therefore  
4           desirable to provide a system that is amenable to oil sands blending;
- 5           • The system involves a line of sequential equipment units and steps.  
6           Therefore, periodic upsets along the processing line can create  
7           problems both upstream and downstream. It follows that surge  
8           capabilities and inventory supply along the line are therefore  
9           desirable, together with the feasibility of bypassing units if required;
- 10          • The mining operations can be remote from the gravity separation  
11          and cleaning process operations and this separation usually  
12          increases steadily as mining proceeds. So a system adapted to  
13          cope with on-going variation in separation is desirable;
- 14          • The bitumen constitutes only a small fraction of the oil sand. The  
15          main component is sand. The sand is, of course, without value and  
16          thus there is incentive to separate it out of the slurry at the first  
17          opportunity and deposit it as fill in the mine pit. So a system which is  
18          amenable to this end is desirable; and
- 19          • Of course it is desirable that the recovery of bitumen be maximized  
20          and the loss of bitumen with the tailings minimized.

21           In the early embodiments of these facilities, the as-mined oil sand was  
22           transported on belt conveyors from the mine sites to central processing  
23           plants. However, the conveyors, often stretching for miles, were expensive  
24           and difficult to operate. Later it was found feasible to crush and mix the oil



1 sand with heated water at the mine site and then pump the resulting slurry  
2 through a pipeline directly to a remote PSV. Today, this type of operation is  
3 being implemented as new mining areas are developed. At the applicants'  
4 facility, this scheme more specifically involves:

- 5 • advancing a mobile shovel along the mine face to excavate oil sand and  
6 load it into large trucks which haul the as-mined oil sand some distance to  
7 a double roll crusher;
- 8 • dumping the as-mined oil sand into a hopper feeding the double roll  
9 crusher, which crushes the oil sand to conveyable size (i.e. -24 inches);
- 10 • delivering the crushed ore to a surge pile using a belt conveyor;
- 11 • gravity feeding oil sand from the surge pile to another belt conveyor and  
12 delivering it to the top end of a mixer tower. The mixer tower incorporates  
13 a downwardly descending arrangement of a slurry mixer, a slurry screen  
14 and a pump box. In the course of moving down through the tower  
15 elements, the oil sand is mixed with heated water in the mixer to form the  
16 slurry and the slurry is then screened to remove oversize. The screened  
17 slurry is received in the pump box and the oversize is dumped on the  
18 ground for removal or is transferred to a secondary tower where similar  
19 operations are repeated on the oversize; and
- 20 • then pumping the slurry in the pump box through a pipeline to a PSV  
21 located at a processing plant remote from the mine site.

22 However, the trucks constitute a significant portion of material handling  
23 cost and the distance they must travel becomes greater as the mine face  
24 moves away from the mixer tower.

1 Thus there exists a need for a different combination of processing steps  
2 and equipment units, which eliminates or reduces reliance on trucks and  
3 which can better cope with the gradual advance of the mine face.

4

5

#### **SUMMARY OF THE INVENTION**

6 The phrase "mine site", as used herein, means an area of land  
7 presently undergoing strip mining to excavate oil sand and which has one or  
8 more mine faces and one or more tailings retention facilities, which may be  
9 dike-enclosed areas or mined-out pits.

10 The adjective 'mobile', as used herein, is intended to indicate that  
11 equipment is mounted on driven tracks or the like for on-going advancement  
12 over terrain.

13 The adjective 'relocatable', as used herein, is intended to indicate that  
14 equipment is of a transportable size and on skids or the like, or can be readily  
15 disassembled into transportable sections, whereby it is stationary when  
16 operating but it is feasible to periodically move it from location to location,  
17 perhaps every few months.

18 The term "unit", as used herein, is intended to mean a single piece of  
19 equipment or an assembly of pieces of equipment, which functions to perform  
20 one or more defined steps such as crushing and/or mixing.

21 In accordance with one embodiment of the invention, a process line  
22 comprising a combination of operatively connected mobile and relocatable  
23 equipment units is provided at a mine site. The process line functions to



1 excavate oil sand and produce a stream of pumpable, aerated, aqueous oil  
2 sand slurry. More particularly, the process line comprises:

- 3 • a mobile excavating means for advancing along a mine face and  
4 excavating oil sand;
- 5 • a mobile sizing means for advancing along behind the excavating  
6 means, receiving the oil sand and comminuting it to conveyable size;
- 7 • a relocatable first conveyor means, preferably extending along the  
8 mine face, for receiving the once comminuted oil sand from the sizing  
9 means and conveying it to a slurry preparation location;
- 10 • a relocatable slurry preparation means, at said location, for mixing the  
11 oil sand with heated water and producing a pumpable, aerated,  
12 aqueous oil sand slurry; and
- 13 • a first pipeline means for receiving the slurry and pumping and  
14 transporting it while simultaneously conditioning it, whereby said means  
15 produces a stream of slurry amenable for desanding and delivers it to a  
16 desanding location.

17 In one preferred feature of this embodiment of the process line, a  
18 lengthy first conveyor means, extending along the mine face, permits the  
19 slurry preparation means to remain stationary for a period of time, while  
20 coupling it for oil sand supply with the mobile and advancing excavating and  
21 sizing means.

22 In another feature of this embodiment, the slurry is moved through a  
23 pipeline, while on the mine site, to condition it in preparation for desanding.

1 In another aspect of the described embodiment, a process is provided  
2 comprising the steps of:

- 3 • excavating oil sand progressively along a mine face;
- 4 • comminuting the oil sand to conveyable size;
- 5 • conveying the comminuted oil sand along the mine face to a slurry  
6 preparation location on the mine site;
- 7 • mixing the oil sand with heated water at the slurry preparation  
8 location and producing a pumpable, aerated, aqueous oil sand  
9 slurry; and
- 10 • transporting the slurry through a pipeline from the slurry  
11 preparation location to a desanding location.

12 In an optional extension of the previously described process and  
13 process line, a relocatable desanding means is connected with the first  
14 pipeline means at the desanding location. The desanding means functions to  
15 receive the slurry and separate liquid and sand components of the slurry. It  
16 produces a desanded product, mainly consisting of bitumen, fines and water,  
17 and tailings, which mainly consists of sand, fines and water.

18 The desanding means preferably comprises a circuit of separators,  
19 arranged in series and operating countercurrently, wherein the underflow (or  
20 heavy fraction output) of one separator is fed to the next separator, the  
21 underflow of the last separator is tailings and the overflow (or lighter fraction  
22 output) of the first separator goes to a product pipeline, which transports it  
23 from the mine site, while the overflow of each following separator is recycled  
24 to the preceding separator.

1 It is a feature of the desanding circuit that subjecting separator  
2 underflow to secondary separation improves the probability of recovering  
3 contained bitumen.

4 The underflow of the last separator may be discarded into a dike-  
5 enclosed retention area or mined-out pit or otherwise processed as described  
6 below.

7 In a preferred embodiment, a plurality of such process lines are  
8 employed at the same mine site. As a consequence it is possible to transfer  
9 oil sand ore or slurry between process lines to cope with upsets or equipment  
10 repairs.

11

12

### **DESCRIPTION OF THE DRAWINGS**

13 Figure 1 is a schematic showing the process line for excavating,  
14 conveying and preparing a pipelineable slurry;

15 Figure 2 is a schematic showing the process line at a mine site having  
16 mineable oil sand and employing the steps of: excavating oil sand; conveying  
17 it; mixing it with water to form a slurry; transporting and conditioning the slurry;  
18 and desanding it to produce desanded product and tailings;

19 Figure 3 is a schematic similar to Figure 2 but showing an inclined  
20 settler substituted for a cycloseparator in the desanding circuit;

21 Figure 4 is a schematic showing a plurality of process lines at a mine  
22 site, wherein in one process line a bucket wheel excavator is substituted for a  
23 shovel, and further showing a tailings retention facility and a thickener for  
24 concentrating fine solids from the tailings;



1 Figure 5 is a perspective view of a rotary digester, which may be used  
2 in the process line to form the slurry;

3 Figure 6 is a view similar to Figure 5, showing part of the drum wall  
4 broken away to display internal lifters;

5 Figure 7 is a side view of a cycloseparator, which may be used in the  
6 desanding circuit showing the internal section of the vortex finder in dotted  
7 lines; and

8 Figure 8 is a sectional side view showing an inclined settler.

9

### 10 **DESCRIPTION OF THE PREFERRED EMBODIMENT**

11 A process line 1 in accordance with the invention comprises a series of  
12 operatively connected processing units located at a mine site 2. The mine  
13 site 2 is positioned on a body of mineable oil sand 3, such as exists in the Fort  
14 McMurray region of Alberta. The mine site 2 has one or more mine faces 4, a  
15 slurry preparation location 5, a desanding location 6 and a tailings retention  
16 facility 7. As the mine faces 4 advance, one or both of the locations 5,6 will  
17 periodically advance as well. As shown in Figure 4, a plurality of process  
18 lines 1 may be in use on the mine site 2.

19 In the preferred embodiment (as shown in Figures 1 and 2), each  
20 process line 1 comprises:

- 21 • A mobile mining shovel 10, which is mounted on driven tracks  
22 11. The shovel 10 is positioned at the mine face 4 for  
23 excavating the oil sand 3. It is operative to advance along the  
24 mine face 4. Otherwise stated, the shovel 10 provides mobile

1 excavating means for advancing along the mine face 4 and  
2 excavating oil sand 3;

- 3 • A mobile sizing unit 12 which comprises a surge bin 13, an  
4 apron feeder 16, a double roll crusher 14, and a conveyor and  
5 belt wagon 15. The sizing unit 12 is mounted on one or more  
6 platforms 17, each supported on drive tracks 18.

7 In operation the shovel 10 dumps oil sand 3 into the  
8 surge bin 13. The apron feeder 16 feeds oil sand 3 from the bin  
9 13 to the crusher 14. The crusher 14 comminutes the  
10 excavated oil sand 3 to a size that is conveyable on a belt  
11 conveyor, for example to -24 inch. The feed conveyor 19  
12 deposits the oil sand 3 onto the conveyor and belt wagon 15  
13 which feeds the adjacent mine face conveyor belt 20.

14 In summary, the sizing unit 12 provides mobile sizing  
15 means for advancing along behind the excavating means,  
16 receiving excavated oil sand and comminuting it to conveyable  
17 size;

- 18 • An elongate, relocatable conveyor belt 20 which extends along  
19 the mine face 4. The conveyor belt 20 receives the oil sand 3  
20 from the feed conveyor 19 and conveys it to a surge pile 21  
21 located at the slurry preparation location 5.

22 In summary, a relocatable first conveyor means receives  
23 the oil sand 3 from the sizing means, conveys it to the slurry  
24 preparation location 5 and delivers it thereto;

- 1           • A relocatable slurry preparation unit 25 positioned at the slurry  
2 preparation location 5. The unit 25 comprises the surge pile 21,  
3 a feed conveyor 26, a hopper 27, a feed conveyor 29, a double  
4 roll crusher 30, a feed conveyor 31, a hopper 32, a jet pump 33  
5 and a source 34 of heated water.

6           In operation, oil sand 3 is fed from the surge pile 21 by  
7 the feed conveyor 26 into the hopper 27 and fed by the  
8 conveyor 29 to the crusher 30. The sum of these actions is  
9 referred to collectively as utilizing the oil sand. The crusher 30  
10 comminutes the oil sand to pumpable size, typically –4 inches.  
11 A conveyor 31 feeds the crushed oil sand 3 into the gravity feed  
12 hopper 32 of the jet pump 33. The hopper 32 dispenses the oil  
13 sand 3 into the jet pump 33, where it is entrained into a jet of  
14 motive heated water. A source 34 supplies the water to the jet  
15 pump 33. The jet pump 33 mixes the oil sand 3 and water, while  
16 entraining air, to produce a pumpable, aerated, aqueous oil  
17 sand slurry 35.

18           In summary, there is provided relocatable slurry  
19 preparation means, at the slurry preparation location 5, for  
20 utilizing the oil sand 3 delivered thereto, further comminuting it to  
21 pumpable size and mixing it with heated water to produce a  
22 pumpable, aerated, aqueous oil sand slurry 35;



- 1           • A slurry pipeline 40 which is connected with the outlet of the jet  
2           pump 33 and extends to the desanding location 41. The  
3           pipeline 40 may include one or more slurry pumps 42.

4                     In the course of being pumped through the pipeline 40,  
5           the slurry stream 35 is mixed and conditioned.

6                     In summary, there is provided a first pipeline means,  
7           connected with the slurry preparation means, for receiving the  
8           slurry 35, transporting it while simultaneously conditioning it, and  
9           delivering it to the desanding location 6 for desanding;

- 10           • A relocatable desanding circuit 43, which is positioned at the  
11           desanding location 6 and is connected with the downstream end  
12           of the slurry pipeline 40.

13                     The desanding circuit 43 comprises a series of  
14           countercurrently operating separators. More particularly, the  
15           separators used are centrifugal cyclo separators 44, 45, 46, one  
16           of which is shown in Figure 7. The cyclo separators 44, 45, 46  
17           are, respectively, generally cylindrical, hollow vessels 47, 48, 49  
18           having internal chambers 50, 51, 52, tangential inlets 53, 54, 55  
19           at the upstream end and central vortex finder outlets 56, 57, 58  
20           and peripheral outlets 59, 60, 61 at the downstream ends.

21                     The slurry stream 35 is pumped from the pipeline 40 into  
22           the tangential inlet 53 of the first cyclo separator 44 (shown in  
23           Figure 2). The slurry spins as it advances longitudinally through  
24           the vessel chamber 50. The heavier fraction (mainly sand, fines

1 and some water and bitumen) concentrates outwardly and  
2 leaves the vessel chamber 50 as an underflow stream 62  
3 through the peripheral outlet 59. The lighter fraction (mainly  
4 bitumen, fines and water) concentrates inwardly and leaves the  
5 vessel chamber 50 as a central overflow stream 63 through the  
6 vortex finder outlet 56. The first separator overflow stream 63 is  
7 fed as desanded product to a product pipeline 65 which  
8 transports it from the mine site 2 to a remote processing plant  
9 (not shown). The first separator underflow stream 62 is fed  
10 through outlet 59 and line 66 to the inlet 54 of the second  
11 separator 45. The same type of centrifugal separation occurs in  
12 the second separator chamber 51. The overflow stream 67 from  
13 the second separator chamber 51 is recycled through line 68 to  
14 the inlet 53 of the first cycloseparator 44. The underflow stream  
15 69 from the second cycloseparator 45 is fed through the line 70  
16 to the inlet 55 of the third cycloseparator 46. Water may also be  
17 added as required through line 71 to the inlet 55 of the third  
18 cycloseparator 46, as the underflow stream, 69 may need  
19 dilution. The overflow stream 72 from the third cycloseparator  
20 46 is recycled through line 73 to the inlet 54 of the second  
21 cycloseparator 45. The underflow stream 74 from the third  
22 cycloseparator 46 is removed through the line 75 as tailings.

23 In summary, there is provided relocatable desanding  
24 means, at the desanding location and connected with the first

1 pipeline means, for receiving the slurry and separating liquid and  
2 sand components of the slurry to produce separate streams of  
3 desanded product and tailings;

- 4 • Means are provided for depositing the tailings at the retention  
5 facility 7 (see Figure 4). In the preferred embodiment, a mobile  
6 boom 80, carrying a cyclone 81 at its upper end, is positioned  
7 alongside the retention facility. The line 74 feeds the stream  
8 of tailings to the cyclone 81, which separates the tailings  
9 components to produce an underflow stream 82, mainly  
10 comprising sand and some water, and an overflow stream 83,  
11 mainly comprising water and fine solids (clay). The underflow  
12 stream 82 is deposited on the beach 84 of the retention facility  
13 7. The overflow stream 83 is conveyed through a line 85 to a  
14 thickener 86. The thickener 86 separates the cyclone overflow  
15 components to produce a paste-like underflow stream 87, which  
16 is deposited in the mined out pit, and a water stream 88 which  
17 may be recycled to the desanding circuit 43.

#### 18 Variants

19 It is to be understood that applicants contemplate that a person skilled  
20 in the art may substitute units without significantly affecting the way in which  
21 the process line 1 works.

22 For example:

- 23 • A bucketwheel excavator 90, shown in Figure 4, may be  
24 substituted for the shovel 10;



- 1           • A rotary digester 91, shown in Figures 5, 6, may be substituted  
2           for the jet pump 33. The digester 91 is capable of processing  
3           larger lumps of oil sand and thus may not require a secondary  
4           crusher 30.

5           The digester 91 is a rotatable drum 92 having internal  
6           lifters 93, drive means 94, a trommel screen 95 and crawlers  
7           108. The oil sand and water are fed into a feed box 96 via feed  
8           conveyor 110 and are tumbled within the drum 92 to mix them  
9           and condition the produced slurry. The screen 95 removes  
10          oversize which oversize is removed via reject chute 104. The  
11          screened slurry drops into pump box 106 and pumped through  
12          pipeline 40 by pump 97; and

- 13          • an inclined plate separator 100, shown in Figure 8, may be  
14          substituted for a cycloseparator.

15          The slurry is fed into the bottom inlet 99 of the separator 100 from  
16          pipeline 40. The sand separates and drops along the internal plates 101 and  
17          is withdrawn through the outlet 102. The water, some bitumen and fine solids  
18          leave through the top outlet 103.

19          The scope of the invention is defined by the claims now following.

1           **THE EMBODIMENTS OF THE INVENTION IN WHICH AN EXCLUSIVE**  
2           **PROPERTY OR PRIVILEGE IS CLAIMED ARE DEFINED AS FOLLOWS:**

3  
4           1. A process line for producing an oil sand slurry at a mine site having  
5           mineable oil sand, a mine face, a slurry preparation location and a desanding  
6           location, comprising the following individual units of equipment serially  
7           associated with one another within the mine site:

8                 mobile excavating means for advancing along the mine face and  
9           excavating oil sand;

10                mobile sizing means for advancing along behind the excavating means,  
11           receiving excavated oil sand and comminuting the excavated oil sand to  
12           conveyable size;

13                relocatable first conveyor means for receiving the oil sand from the sizing  
14           means, conveying the oil sand to the slurry preparation location and delivering  
15           the oil sand thereto;

16                relocatable slurry preparation means, at the slurry preparation location, for  
17           producing a pumpable, aerated, aqueous oil sand slurry, comprising a jet pump  
18           for mixing the oil sand with heated water, a hopper for feeding the oil sand to the  
19           jet pump and means for supplying heated water to the jet pump; and

20                first pipeline means, connected with the slurry preparation means, for  
21           receiving the slurry, transporting the slurry while simultaneously conditioning the  
22           slurry and delivering the conditioned slurry to the desanding location for  
23           desanding;

1       whereby each individual unit of equipment is capable of independently moving  
2       closer to the mine face when the mine face recedes and the need arises for that  
3       individual unit of equipment to do so.

4  
5               2. The process line as set forth in claim 1 wherein the first conveyor  
6       means is a belt conveyor extending along the mine face.

7  
8               3. A process line for producing desanded product, comprising bitumen  
9       and water, and tailings, comprising sand and water, at a mine site having  
10      mineable oil sand, a mine face, a slurry preparation location and a desanding  
11      location, the following individual units of equipment serially associated with one  
12      another within the mine site:

13              mobile excavating means for advancing along the mine face and  
14      excavating oil sand;

15              mobile sizing means for advancing along behind the excavating means,  
16      receiving excavated oil sand and comminuting the oil sand to conveyable size;

17              relocatable first conveyor means for receiving the oil sand from the sizing  
18      means, conveying the oil sand to the slurry preparation location and delivering  
19      the oil sand thereto;

20              relocatable slurry preparation means, at the slurry preparation location, for  
21      producing a pumpable, aerated, aqueous oil sand slurry, comprising a jet pump  
22      for mixing the oil sand with heated water, a hopper for feeding the oil sand to the  
23      jet pump and means for supplying heated water to the jet pump;



1 first pipeline means, connected with the slurry preparation means, for  
2 receiving the slurry, transporting the slurry while simultaneously conditioning the  
3 slurry and delivering the slurry to the desanding location; and

4 relocatable desanding means, at the desanding location and connected  
5 with the first pipeline means, receiving the slurry and separating liquid and sand  
6 components of the slurry to produce separate streams of desanded product and  
7 tailings;

8 whereby each individual unit of equipment is capable of independently moving  
9 closer to the mine face when the mine face recedes and the need arises for that  
10 individual unit of equipment to do so.

11  
12 4. The process line as set forth in claim 3 comprising:

13 a product pipeline, connected with the desanding means, for transporting  
14 the desanded product stream from the mine site.

15  
16 5. The process line as set forth in claim 4 wherein the mine site has a  
17 tailings retention facility and comprising:

18 means, connected with the desanding means, for depositing tailings at the  
19 retention facility.

20  
21 6. The process line as set forth in claim 3, 4 or 5 wherein the desanding  
22 means comprises:

1 a series of countercurrently operating separators for progressively treating  
2 slurry to separate bitumen from sand.

3  
4 7. The process line set forth in claim 3, 4 or 5 wherein:  
5 the first conveyor means extends along the mine face; and  
6 the desanding means comprises a series of countercurrently operating  
7 separators for progressively treating slurry to separate bitumen from sand.

8  
9 8. The process line of claim 1, 2, 3, 4, 5, 6 or 7 wherein:  
10 the sizing means comprises a surge bin for receiving and dispensing  
11 excavated oil sand, a double roll crusher for comminuting the dispensed oil sand  
12 and means for conveying the dispensed oil sand from the surge bin to the  
13 crusher.

14  
15 9. A process line for producing an oil sand slurry at a mine site having  
16 mineable oil sand, a mine face, a slurry preparation location and a desanding  
17 location, comprising the following individual units of equipment serially  
18 associated with one another within the mine site:

19 mobile excavating means for advancing along the mine face and  
20 excavating oil sand;

21 mobile sizing means for advancing along behind the excavating means,  
22 receiving excavated oil sand and comminuting the excavated oil sand to  
23 conveyable size;

1           relocatable first conveyor means for receiving the oil sand from the sizing  
2 means, conveying the oil sand to the slurry preparation location and delivering  
3 the oil sand thereto;

4           relocatable slurry preparation means, at the slurry preparation location, for  
5 producing a pumpable, aerated, aqueous oil sand slurry, comprising a rotary  
6 digester, means for receiving oil sand from the first conveyor means and feeding  
7 the oil sand to the rotary digester and means for supplying heated water to the  
8 rotary digester; and

9           first pipeline means, connected with the slurry preparation means, for  
10 receiving the slurry, transporting the slurry while simultaneously conditioning the  
11 slurry and delivering the conditioned slurry to the desanding location for  
12 desanding;

13 whereby each individual unit of equipment is capable of independently moving  
14 closer to the mine face when the mine face recedes and the need arises for that  
15 individual unit of equipment to do so.

16  
17           10. A process line for producing desanded product, comprising bitumen  
18 and water, and tailings, comprising sand and water, at a mine site having  
19 mineable oil sand, a mine face, a slurry preparation location and a desanding  
20 location, comprising the following individual units of equipment serially  
21 associated with one another within the mine site:

22           mobile excavating means for advancing along the mine face and  
23 excavating oil sand;



1 mobile sizing means for advancing along behind the excavating means,  
2 receiving excavated oil sand and comminuting the oil sand to conveyable size;

3 relocatable first conveyor means for receiving the oil sand from the sizing  
4 means, conveying the oil sand to the slurry preparation location and delivering  
5 the oil sand thereto;

6 relocatable slurry preparation means, at the slurry preparation location, for  
7 producing a pumpable, aerated, aqueous oil sand slurry, comprising a rotary  
8 digester, means for receiving oil sand from the first conveyor means and feeding  
9 the oil sand to the rotary digester and means for supplying heated water to the  
10 rotary digester;

11 first pipeline means, connected with the slurry preparation means, for  
12 receiving the slurry, transporting the slurry while simultaneously conditioning the  
13 slurry and delivering the conditioned slurry to the desanding location; and

14 relocatable desanding means, at the desanding location and connected  
15 with the first pipeline means, for receiving the conditioned slurry and separating  
16 liquid and sand components of the slurry to produce separate streams of  
17 desanded product and tailings;

18 whereby each individual unit of equipment is capable of independently moving  
19 closer to the mine face when the mine face recedes and the need arises for that  
20 individual unit of equipment to do so.

21  
22 11. The process line of claim 9 or 10 wherein the first conveyor means is  
23 a belt conveyor extending along the mine face.

1

2

12. The process line as set forth in claim 10 or 11 wherein the desanding means comprises:

3

4

a series of countercurrently operating separators for progressively treating slurry to separate bitumen from sand.

5

6

7

13. The process line as set forth in claim 10, 11 or 12 comprising:

8

a product pipeline, connected with the desanding means, for transporting the desanded product stream from the mine site.

9

10

11

14. The process line as set forth in claim 13 wherein the mine site has a tailings retention facility and comprising:

12

13

means, connected with the desanding means, for depositing tailings at the retention facility.

14

15

16

15. The process line as set forth in claim 6, 7 or 12 wherein at least one separator is cycloseparator.

17

18

19

16. The process line as set forth in claim 6, 7 or 12 wherein at least one separator is an inclined plate settler.

20

21

22

17. The process line as set forth in claim 1 or 3 wherein the slurry preparation means further comprises a surge means for receiving and dispensing

23

1 oil sand from the first conveyor means, a double roll crusher for comminuting the  
2 oil sand, means for conveying oil sand from the surge means to the double roll  
3 crusher and means for conveying oil sand from the double roll crusher to the  
4 hopper.



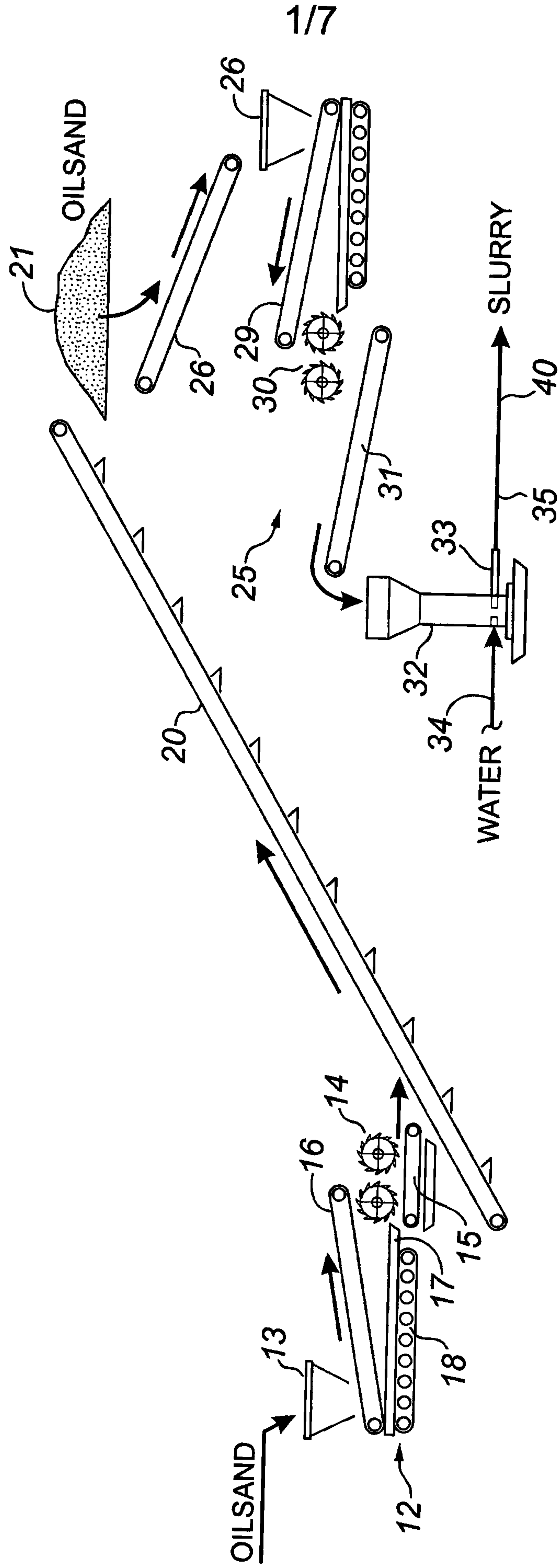

FIG. 1

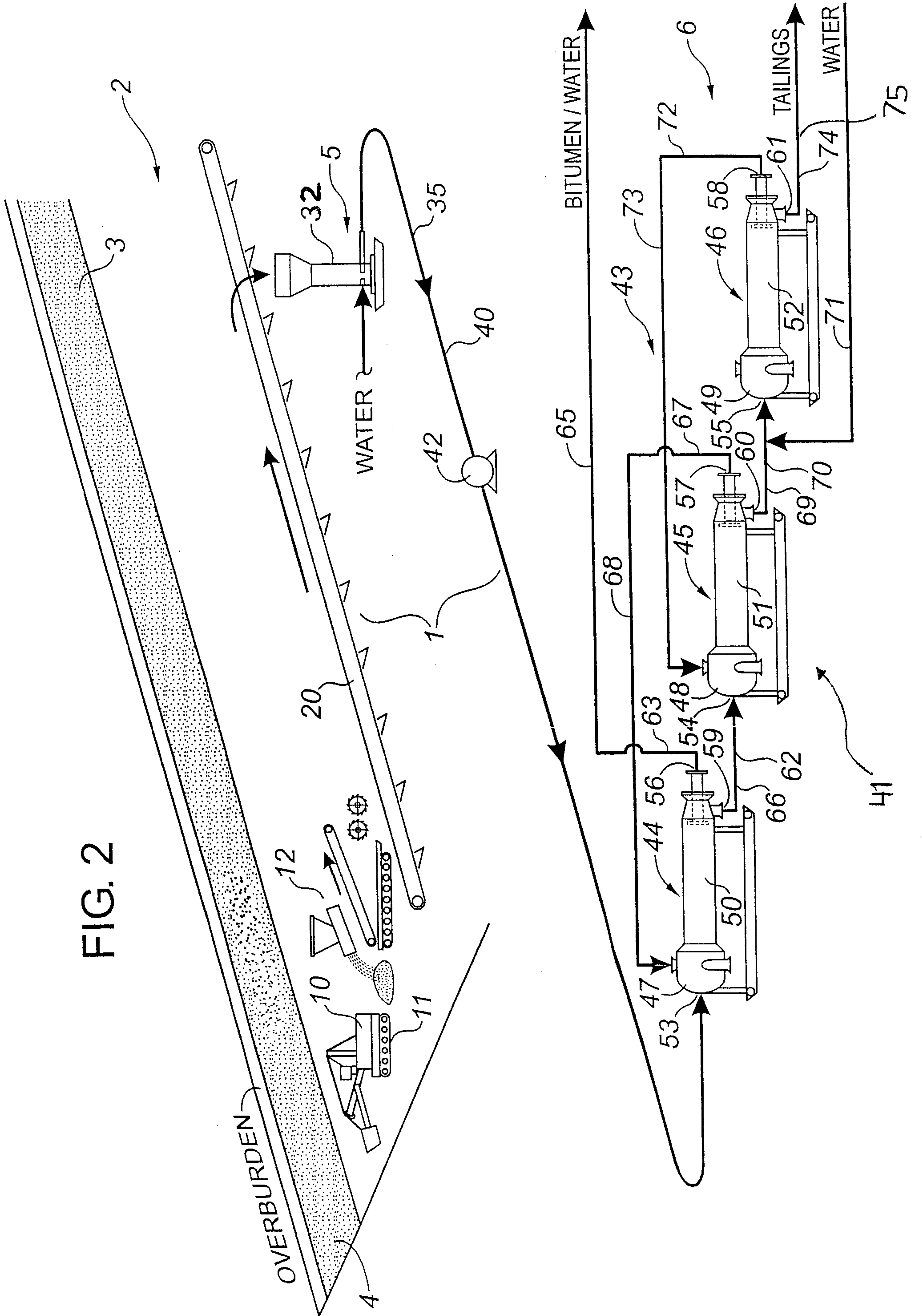
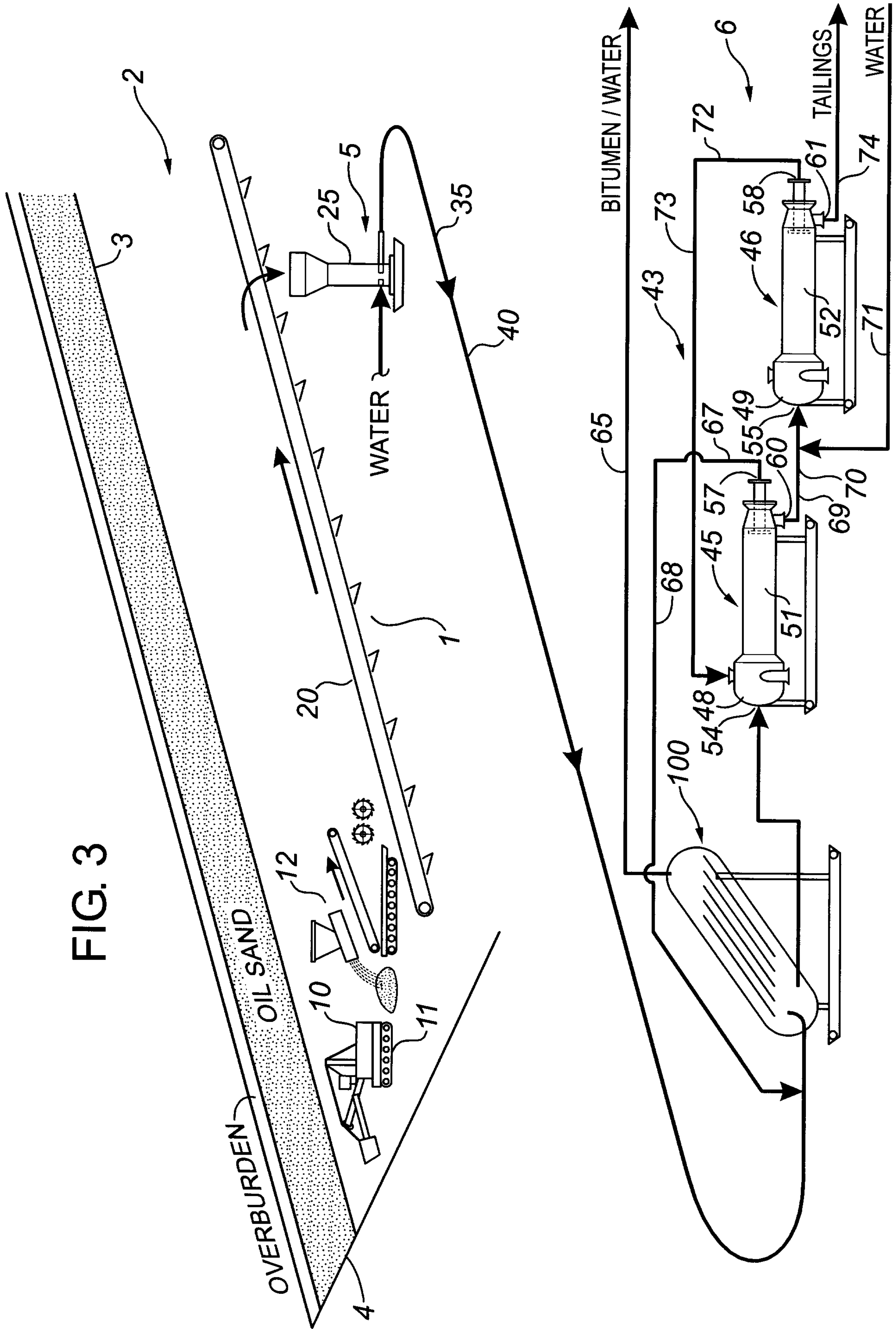

FIG. 3





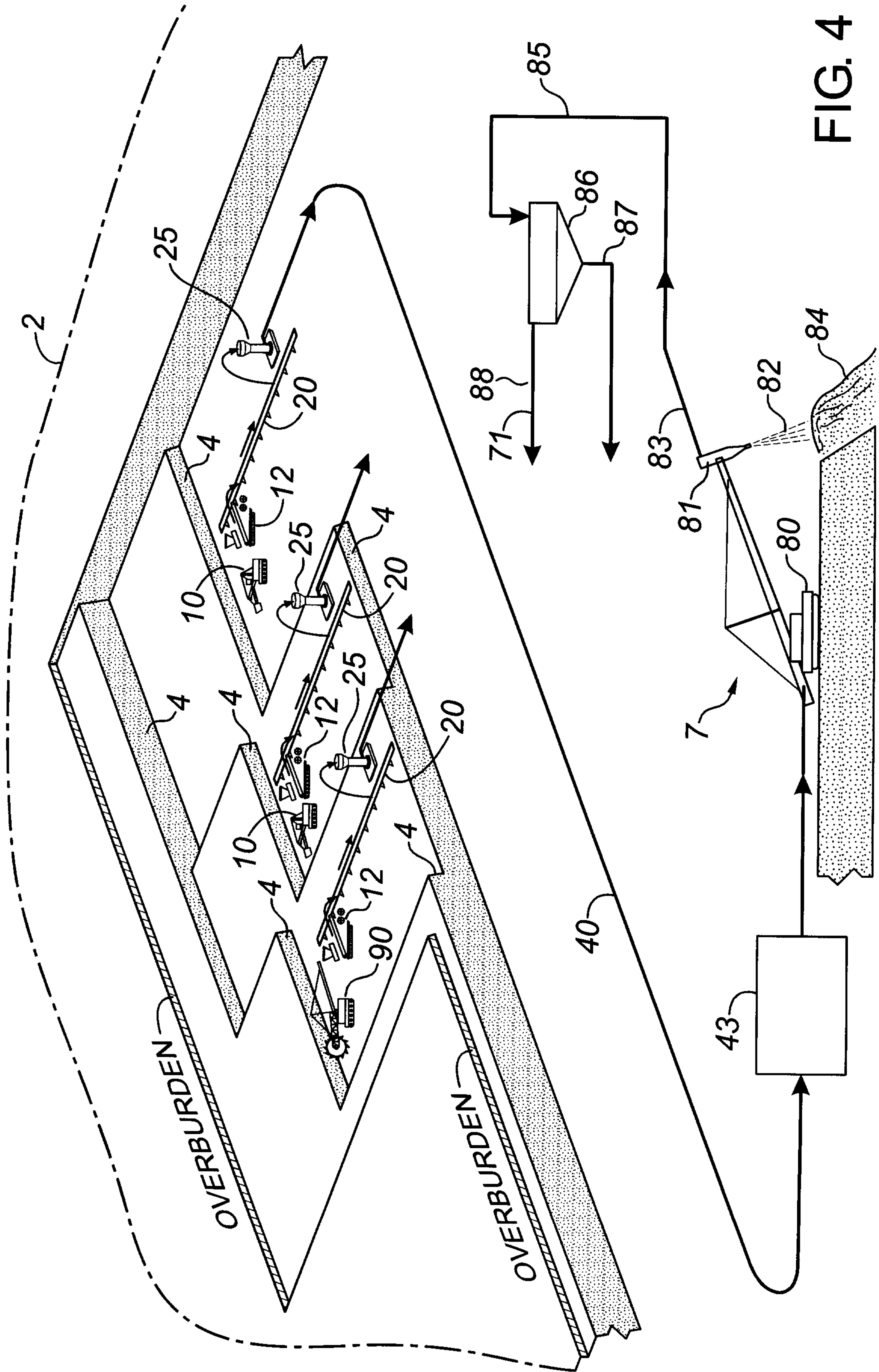

FIG. 4

5/7

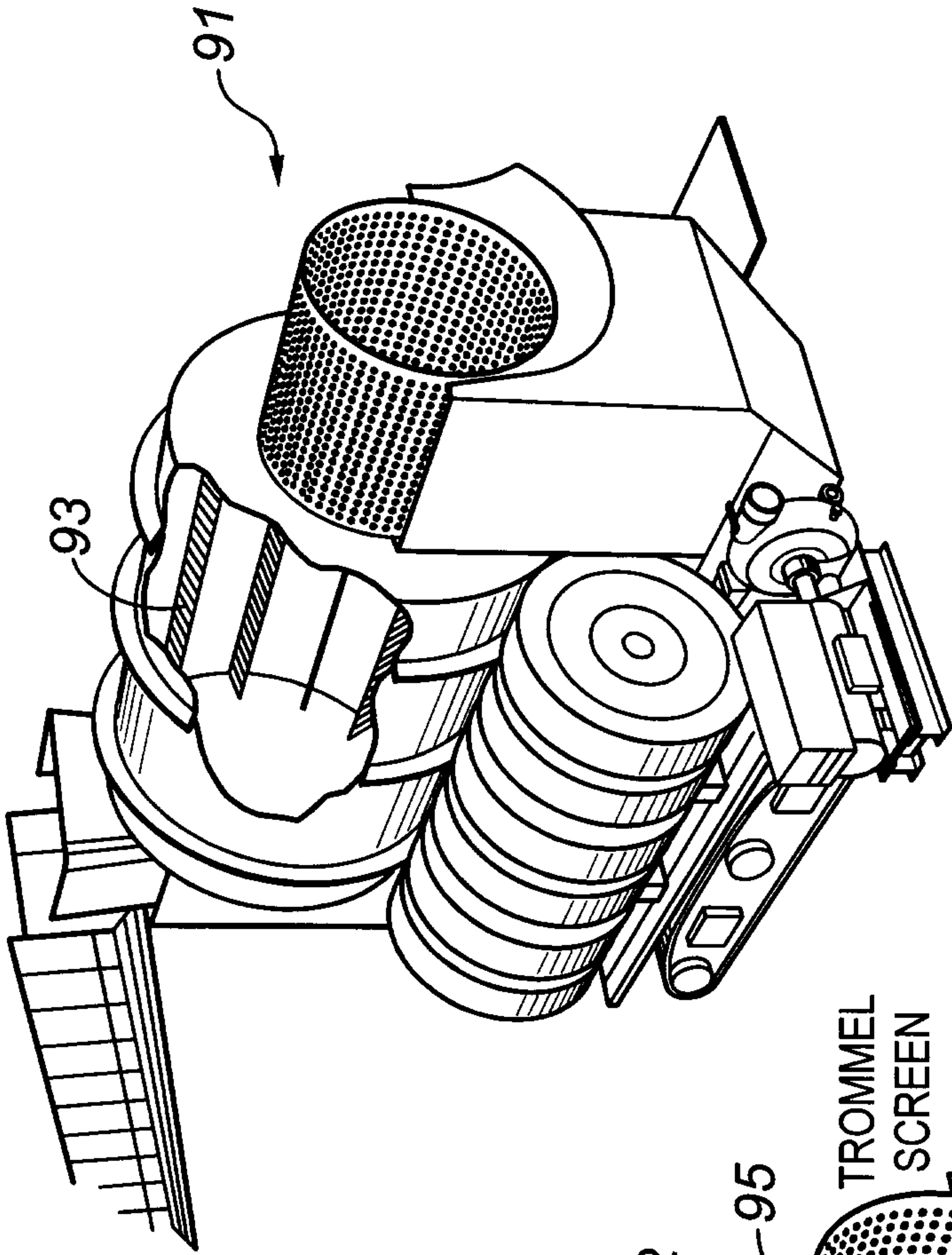

FIG. 6

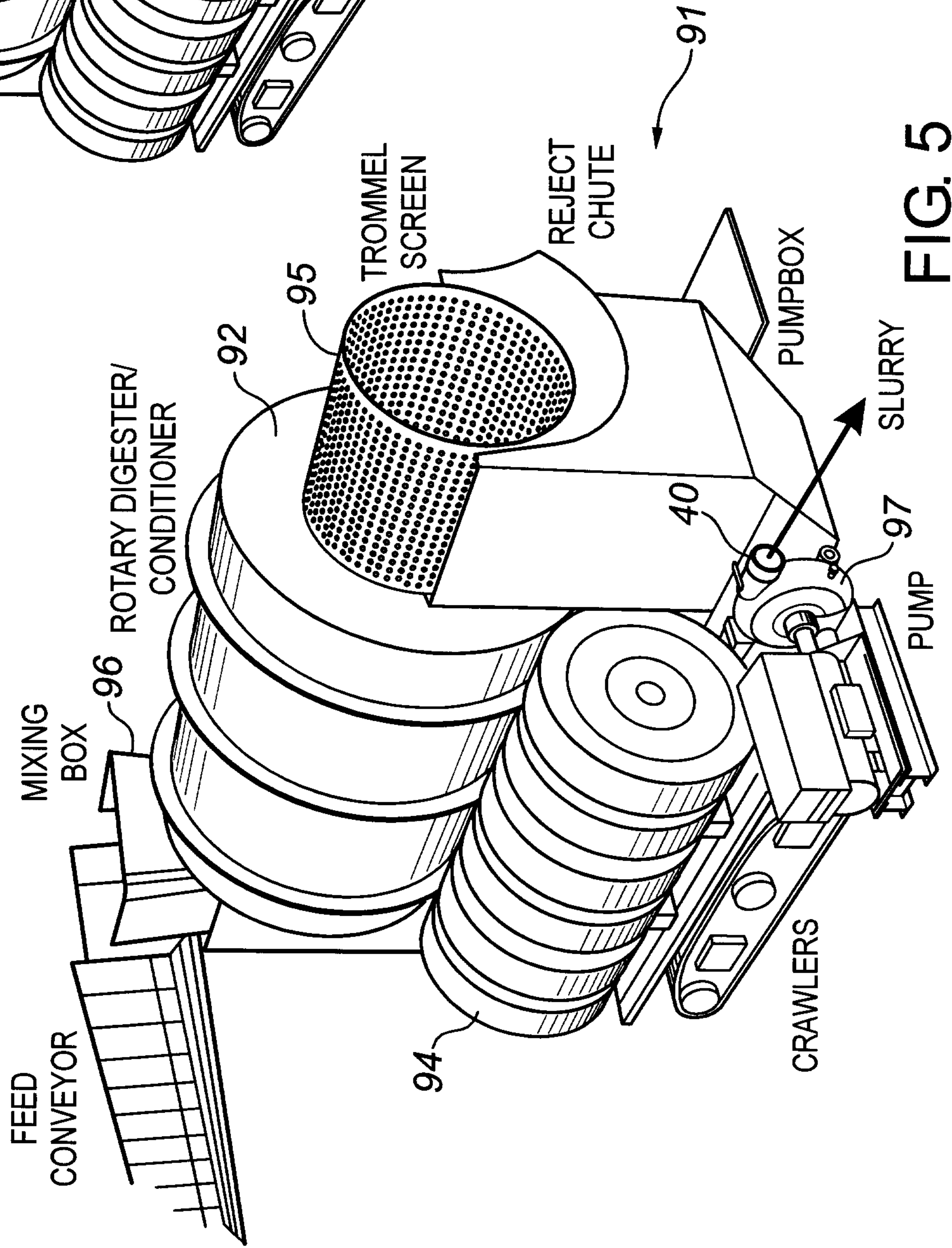

FIG. 5

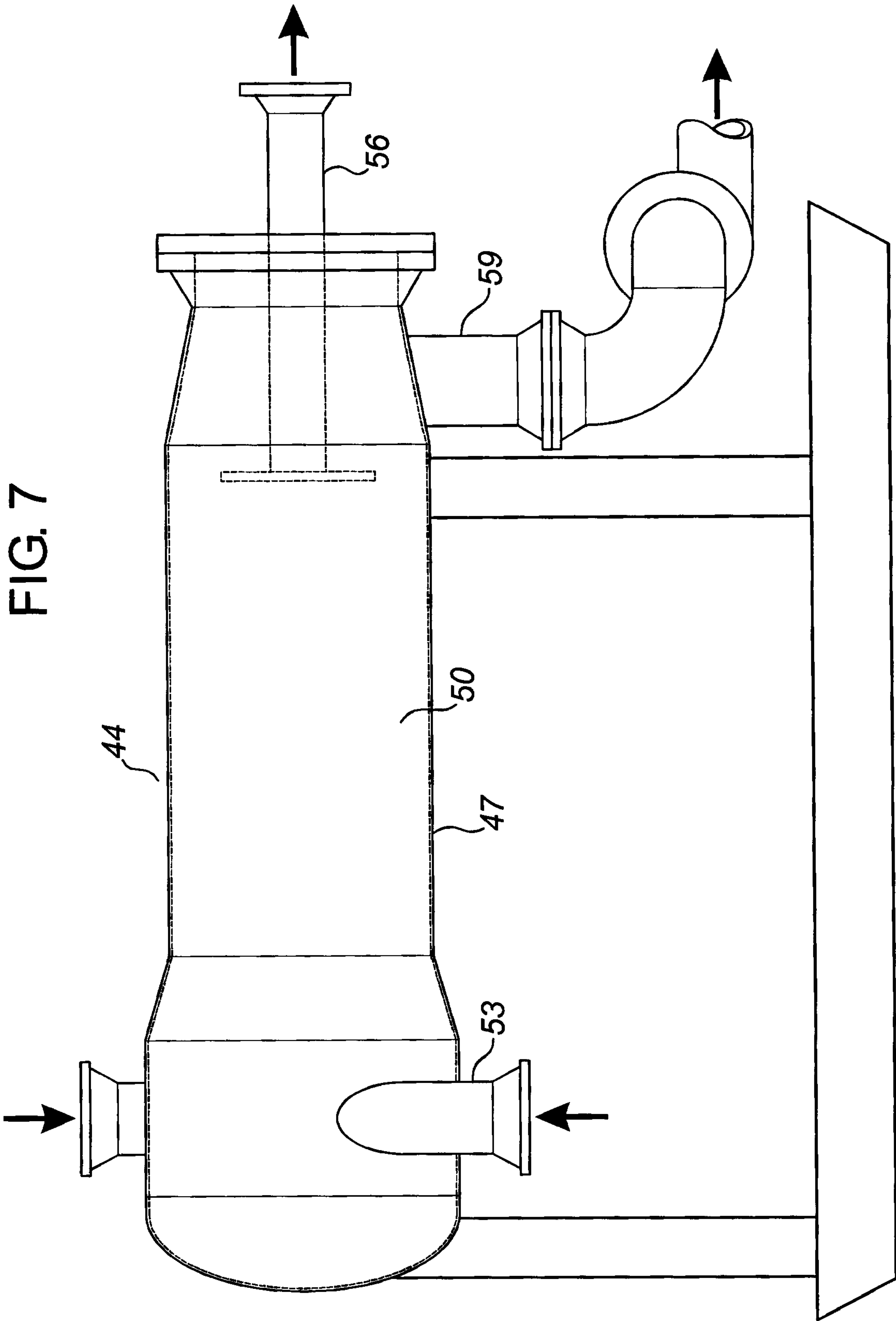



FIG. 8

