



INTERNATIONAL APPLICATION PUBLISHED UNDER THE PATENT COOPERATION TREATY (PCT)

<p>(51) International Patent Classification ⁵ : A61M 25/00, B28B 3/20 B29C 47/00</p>	<p>A1</p>	<p>(11) International Publication Number: WO 93/23105 (43) International Publication Date: 25 November 1993 (25.11.93)</p>
<p>(21) International Application Number: PCT/US93/04370 (22) International Filing Date: 10 May 1993 (10.05.93) (30) Priority data: 07/881,422 11 May 1992 (11.05.92) US (71) Applicant: AMERICAN INTERVENTIONAL TECHNOLOGIES, INC. [US/US]; 1999 Parker Court, Suite E, Stone Mountain, GA 30087 (US). (72) Inventors: BROWN, Joe, E. ; 5157 Parkview Court, Lilburn, GA 30247 (US). PURSLEY, Matt, D. ; Route 4, Box 4219-A, Dawsonville, GA 30534 (US). CLARK, D., Joe ; 6198 Rotondo Place, Norcross, GA 30093 (US).</p>		<p>(74) Agent: HINKLE, James, A.; 390 Crogan Street, N.W., Suite 300, Lawrenceville, GA 30245 (US). (81) Designated States: CA, JP, European patent (AT, BE, CH, DE, DK, ES, FR, GB, GR, IE, IT, LU, MC, NL, PT, SE). Published <i>With international search report. Before the expiration of the time limit for amending the claims and to be republished in the event of the receipt of amendments.</i></p>
<p>(54) Title: REINFORCED CATHETER AND METHOD OF MANUFACTURING</p>		
<p>(57) Abstract</p> <p>A high torque, thin walled guiding catheter (1) has resilient reinforcement material (8, 23, 29, 70, 73) integrally spiraled or braided into monolithic walls (21) of flexible material. A solid lubricant, also referred to as dry lubricant, comprised of either special fluorine containing materials or polymeric organic silicon compounds is embedded into interior and exterior wall surfaces of the catheters. Smooth interior walls (11) are channeled (10) to decrease friction resistance, to trap resistance particles and to dissipate friction heat in the high ratio of surface area to cross-sectional area of small catheters. Number of spirals or braids of reinforcement strands per unit of length, number of layers of strands of the catheters, catheter diameter and progressiveness thereof are designedly different for separate portions of particular catheters. Catheter tips (6) are weldable immediately adjacent to select density of strands of reinforcement material. Perfusion ports are weldable where desired. Directional bends (7) are positioned selectively at distal ends (5) of the catheters (1). Methods for manufacture and modification with co-extrusion, miniature milling and welding while maintaining structural integrity with monolithic wall structure are described.</p>		

FOR THE PURPOSES OF INFORMATION ONLY

Codes used to identify States party to the PCT on the front pages of pamphlets publishing international applications under the PCT.

AT	Austria	FR	France	MR	Mauritania
AU	Australia	GA	Gabon	MW	Malawi
BB	Barbados	GB	United Kingdom	NL	Netherlands
BE	Belgium	GN	Guinea	NO	Norway
BF	Burkina Faso	GR	Greece	NZ	New Zealand
BG	Bulgaria	HU	Hungary	PL	Poland
BJ	Benin	IE	Ireland	PT	Portugal
BR	Brazil	IT	Italy	RO	Romania
CA	Canada	JP	Japan	RU	Russian Federation
CF	Central African Republic	KP	Democratic People's Republic of Korea	SD	Sudan
CG	Congo	KR	Republic of Korea	SE	Sweden
CH	Switzerland	KZ	Kazakhstan	SK	Slovak Republic
CI	Côte d'Ivoire	LI	Liechtenstein	SN	Senegal
CM	Cameroon	LK	Sri Lanka	SU	Soviet Union
CS	Czechoslovakia	LU	Luxembourg	TD	Chad
CZ	Czech Republic	MC	Monaco	TG	Togo
DE	Germany	MG	Madagascar	UA	Ukraine
DK	Denmark	ML	Mali	US	United States of America
ES	Spain	MN	Mongolia	VN	Viet Nam
FI	Finland				

Reinforced Catheter and Method of Manufacturing

Technical Field of the Invention.

The present invention relates generally to the field of catheters.
5 More particularly it relates to guiding catheters having torque transmittal guidance walls that are flexible linearly but not circumferentially and that are neither collapsible nor kinkable. It is particularly suited as a vascular catheter.

Background Art.

Vascular catheters and some other types of catheters requiring remote
10 guidance of insertion from outside of a patient have fine spiralled or braided metallic or non-metallic strands of reinforcement material in thin cylindrical walls of flexible catheter tubing. The catheter body must (a) contain fluid pressures up to 1,000 psi, (b) transmit rotational torque accurately from a proximal end outside of a patient to a distal end inside of the patient, (c) prevent collapse, kinking or
15 alteration of conveyance area of the catheter, (d) convey electrical current or sound wave energy from end-to-end of the catheter and yet, (e) flex sufficiently not to injure bodily tissues. Diagnostic instrumentation, traceable fluids, medicine and body fluids must be conveyed through the catheter lumen effectively. Total diameter of the catheter tubing, however, is often less than one-tenth of an inch.

20 Guidance of such catheters within vascular and other body channels is achieved usually by selectively slight rotation of the catheter with a small handle at the proximal end. At the distal end near a non-injurious tip of the catheter inside of the patient, there is generally a curved directional bend. The slight rotation of the catheter points this directional bend precisely in a desired circumferential
25 direction at a particular position of confluence or other physical condition of the

2.

body lumens or channels. This directs or guides insertional advancement of the catheter into desired body channels or lumens. Other guidance means employ unbent catheters in combination with various steerable tips.

5 A variety of problems have occurred with these small guiding catheters and related components previously. One problem has been a tendency of reinforcement strands to separate from polymer or various flexible materials from which the body of the catheter tubing is constructed. This destroys rotational torque transmittal capacity and leaves the catheter subject to kinking, collapse and general failure of its design requirements.

10 Another problem has been insufficient lubricity of inside catheter walls for conveyance of instrumentation, liquids and slurries of diagnostic and medicinal materials with low viscosity. Outside walls of catheters also have had inadequate lubricity for passage in and out of relatively small body channels.

15 Another problem has been inadequately resilient directional bends at distal ends of catheters. Some have been too rigid. Others have been the opposite without sufficient resilience memory to regain a directional curve after being straightened or bent differently in various portions of body channels.

20 A relatively common problem has been incapacity of a catheter having sufficient linear flexibility to convey rotational torque between a reinforced catheter body and a desirably flexible or soft catheter tip.

Still another problem has been incapacity of previous catheters to be drilled or welded to form side apertures referred to as perfusion ports. The walls of present catheters delaminate, separate and fail from heat of either drilling or welding.

25 Solving these and other problems has inspired this invention.

Different but pertinent catheter technology is described in the following patent documents.

	<u>NATION</u>	<u>NUMBER</u>	<u>DATE</u>	<u>NAME</u>
	European	O 421 650 A1	Apr. 10, 1991	Frassica
5	U.S.	4,764,324	Aug. 16, 1988	Burnham
	U.S.	4,676,229	Jun. 30, 1987	Krasnicki et al
	U.S.	4,577,543	Mar. 25, 1986	Wilson
	U.S.	4,531,943	Jul. 30, 1985	Van Tassel et al
	U.S.	4,425,919	Jan. 17, 1984	Alston, Jr. et al
10	U.S.	3,924,632	Dec. 9, 1975	Cook
	U.S.	3,498,286	Mar. 3, 1970	Polanyi et al

The Frassica European Patent taught rolled layers of polymeric film interspersed with reinforcement materials and various instrumentation elements. High versatility of construction was a main feature of that patent. A wide variety of features could be provided at various portions of the catheter body. Problems, however, were tendency of the layers to separate, large diameter, ridges at linear and circumferential joints and high production cost to achieve variations. Also different from this invention, it could not be customized by mere programming of most of its features into a production process.

The Burnham Patent taught a single extrusion method based on tensioning reinforcement strands being wound around heat softened thermoplastic catheter walls to draw the strands radially into the walls after they were formed. Different from this invention, however, it was not a process that applied catheter wall material inside and outside of the reinforcement strands during a simultaneous co-extrusion and strand winding process to form monolithic walls with tightly woven reinforcement strands. It had no solid lubrication in its walls. There was no wall interruption or channelling for friction reduction. Its reinforcement was not sufficiently variable linearly. There was no means for welding tips in close proximity

to torque transmittal reinforcement strands to transmit torque effectively or to prevent tips from coming off inside of patients. Nor was there means for providing profusion ports and other features without destroying structural integrity of the catheter.

5 The Krasnicki et al Patent described an endoscope biopsy channel with a lubricous inner layer bounded by high strength wire helically wound around it. A soft outer layer provided protection against injury of tissue. Flexible material filled space between wire strands and between the lubricous inner wall and the soft outer wall. That catheter was not producible with sufficiently small diameters and
10 thin walls. Separate walls inside and outside of helical windings consume too much space for small diameter production or for space efficient large diameter catheters.

 The Wilson Patent taught a method to form what it referred to as a monolithic construction of cannulae that could be used for a catheter.
15 Reinforcement strands were wound around the outside of a catheter tube that was then heated to cause the strands to adhere to the outside of the tube. In an optional subsequent step of the method, an additional layer of material was extruded onto the outside of the reinforcement strands. Unlike this invention, however, that method was not a simultaneous co-extrusion and wrapping process
20 that formed a more integrated monolithic wall with less likelihood of separation. There was no solid lubricant at surfaces nor friction reduction channels between solid lubricant surfaces. There was no method for attaching integral tips nor providing profusion ports without destroying structural integrity.

 The Van Tassel et al Patent taught the attachment of a soft balloon like tip
25 to ends of catheters. But it was not a method that could be used for attachment to reinforced walls because it required step cutting of the catheter wall.

5.

The Alston, Jr. et al Patent positioned flat wire braiding between layers of material. This required thick walls in proportion to diameter of catheters. Separation of the layers was problematic for thin walls with that type of construction. It was not a monolithic type of wall taught by this invention.

5 The Cook Patent employed conventional sandwiching of fiberglass woven roving between plastic layers of tubing. Walls were far too thick for the conveyance efficiency required for current medical practices.

10 The Polanyi et al Patent combined a wide variety of catheter features in a catheter wall. But the constructional form was far too thick and the cost of construction too high in comparison to present catheters. It was one of the first catheters to utilize fiber optics, but in forms that have been superseded with smaller and more efficient fiber optics and diagnostic equipment made possible with this invention. Its walls and linear components would separate if made sufficiently thin for current catheter applications.

15 Disclosure of Invention.

In accordance with the present invention, it is contemplated that one objective of this invention is to provide a catheter with a high ratio of torque transmittal capacity from end-to-end for accurate and reliable rotational positioning of a guiding tip at a distal end of the catheter.

20 Another objective is to provide selective resilience and circumferential torque transmission at different linear portions of a catheter.

Another objective is to provide high lubricity of both inside and outside peripheral surfaces of a catheter.

Another objective is to provide perfusion ports at select portions of a catheter without weakening torque transmission, cylindrical integrity, structural integrity, flexibility or resilience of a catheter.

5 Another objective is to provide a catheter having thinner walls and a smaller outside diameter in proportion to inside diameter than present catheters.

Another objective is to provide a soft and smooth catheter tip immediately at the distal end of either progressively decreased or continued reinforcement density of a catheter.

10 Yet another objective of this invention is to provide methods for constructing catheters having characteristics provided by this invention.

This invention accomplishes the above and other objectives with a catheter having strands of resilient reinforcement material integrally spiraled or braided into monolithic walls of flexible material. A solid lubricant, also referred to as dry lubricant, comprised of either special fluorine containing materials or polymeric organic silicon compounds is embedded into interior and exterior wall surfaces of the catheters. Smooth interior walls are channeled to decrease friction resistance, to trap resistance particles and to dissipate friction heat in the high ratio of surface area to cross-sectional area of small catheters. Number of spirals or braids of reinforcement strands per unit of length, number of layers of strands of the catheters, catheter diameter and progressiveness thereof are designedly different for separate portions of particular catheters. Catheter tips are weldable immediately adjacent to select density of strands of reinforcement material. Perfusion ports are weldable where desired. Directional bends are positional selectively at distal ends of the catheters. Methods for manufacture and modification with co-extrusion, miniature milling and welding while maintaining structural integrity with monolithic wall structure are described.

15

20

25

Other objects, advantages and capabilities of the invention will become apparent from the following description taken in conjunction with the accompanying drawings showing preferred embodiments of the invention.

Brief Description of the Drawings.

5 Figure 1 is a cutaway side view of a luer and proximal end section of a catheter using this invention;

 Figure 2 is a distal end and tip of a catheter using this invention;

 Figure 3 is a cutaway sectional view of a catheter with reinforced monolithic walls in an embodiment of this invention;

10 Figure 4 is a cutaway side view of prior art using layered rather than monolithic walls;

 Figure 5 is a cutaway side view of a monolithic wall with a ridged inside wall in an embodiment of this invention. It is positioned immediately beside the prior art which is so labeled for ease of comparison;

15 Figure 6 is a layout of co-extrusion construction of this invention. Stages of construction of the catheter in select embodiments are related to co-extrusion steps with phantom lines;

 Figure 7 is a section of etched mandrel of an in place type employed for particular spiral or opposite direction spiral embodiments of this invention;

20 Figure 8 is a section of a catheter that has been formed on the Figure 7 mandrel;

Figure 9 is a side view of a mandrel of the sliding type showing rotatable spiral forming and opposite direction spiral forming appendages;

Figure 10 is a front view of the Figure 9 illustration;

5 Figure 11 is a cutaway sectional view of a catheter being formed on an in place heat expandable mandrel that is being heated from the outside to heat expand the mandrel and force inside walls of the catheter between reinforcement strands to form friction reduction channels in the inside walls;

10 Figure 12 is a sectional view of a catheter with varied density of reinforcement wrapping at select portions of catheters, such as at the distal end where a tip is attachable;

Figure 13 is a distal end view of a catheter showing reinforcement strands projecting from the catheter walls, particularly if heat were applied for purposes such as welding on a catheter tip without the manufacturing methods taught by this invention;

15 Figure 14 is a side view of a distal end of a catheter that has been stress relief cut selectively for relieving tension of reinforcement strands at a portion of the distal end to be heat welded to a catheter tip;

Figure 15 is a cutaway side view of a distal end of a catheter welded to a catheter tip;

20 Figure 18 is an alternative method of precision heating of the distal end of the catheter and the tip to achieve the final weld shown in Figure 15 in a remote location with great precision;

Figure 16 is a cutaway side view of a subsequent step of inside diameter surfacing welding and smooth welding of the catheter end and tip while heat is being dissipated at the outside diameter to avoid overheating of their matrices;

5 Figure 17 is a cutaway side view of a subsequent step of outside diameter surface welding and smooth welding of the catheter end and tip while heat is being dissipated with a cooling fluid at the inside diameter to avoid overheating their matrices;

10 Figure 19 is a cross-sectional end view of a cryogenically cooled clamping means in relationship to a cutting tool for forming a perfusion port without distorting structural integrity of the catheter;

Figure 20 is a layout illustration of a reinforcement strand being electrostatically coated with select materials in a fluidized bath as the reinforcement strand is being wrapped onto a catheter;

15 Figure 21 is a cross-sectional layout view of welding circumferential sections of a catheter to a tip progressively or sequentially in steps;

Figure 22 is an end view of a multiple strand reinforcement line with a large core member for select transmission of fluid, light or current; and

Figure 23 is an end view of a multiple strand reinforcement line with a uniform diameter core.

20 Best Mode of Carrying Out the Invention.

A catheter with thin monolithic torque transmittal walls and manufacturing methods for the same, wherein a catheter 1 is provided with a handle 2 and a standard internally coned luer connector 3 at a proximal end 4 of the catheter 1.

10,

Referring to Figures 1 and 2, a distal end 5 of the catheter 1 has a catheter tip 6. The distal end 5 of the catheter can have a directional bend 7. The catheter 1 can be steered directionally by circumferentially positioning of the directional bend 7 with handle 2. This points the tip 6 into particular body lumens at their confluence with other body lumens and directs it also into particular portions of body lumens as desired by a practitioner.

In order to point the directional bend 7 precisely in a desired direction at a particular distance of entry of the catheter, it is essential that the catheter 1 not be flexible circumferentially. Yet it must be highly flexible linearly to follow body lumens without injuring them. Also to avoid bodily injury, the catheter tip 6 must be soft and pliable. Circumferential inflexibility is referred to as torque transmission because rotational torque of the handle is transferable directly to the tip 6, even though the catheter 1 may be flexed in various curves of body lumens. In addition, the directional bend must have linear flexibility, resilience and curvature adjustable to particular body conditions. Meeting these requirements with a thin walled catheter having a diameter of a tenth of an inch or less and being able to pass diagnostic instrumentation and fluids through them without rupturing them with frictional resistance have been technical problems that have been solved along with other problems by this invention.

Referring now to Figure 3, reinforcement strands 8 are embedded in a monolithic wall 9 of a catheter 1. Monolithic describes a wall 9 formed without layers of embedding spiralled or cross spiralled strands in the wall. To accomplish this, the wall 9 is co-extruded from inside and outside of the strands while the material for the wall 9 is molten and fusible with the strands 8 included in it. The effect is the same as single extrusion of a monolithic wall with strands mixed in it as effectively as if the circum-ferential strands were particles in a hardenable liquid mixture. There are no layers to separate.

Some walls have been referred to previously as being monolithic when outer layers have been applied after inner layers have hardened and reinforcement strands applied. Arguably, such a layering condition may be monolithic if bonding of the second layer is adequate. However, in the extremely small sizes involved, there is not sufficient area for multiple layers or for their effective bonding. Making walls thin enough to maximize use of space and still have adequate torque transmission and linear flexibility does not allow multiple layers that are effectively bonded to inside and outside diameters of spiralled reinforcement. If prior multiple layering can be termed monolithic, then this invention has a higher grade of monolithic walls.

Friction reduction channels 10 are provided between bore surfaces 11 of a catheter bore 12. Bore ridges 11 decrease surface area of contact of instrumentation inserted in the catheter bore 12. In addition, the material with which the catheter 1 is constructed is impregnated with fluorine containing or silicon containing material for a solid lubrication effect.

Prior art is shown in Figure 4 with an inside layer 13, a reinforcement layer 14 and an outside layer 15 applied later. This demonstrates a structure of prior art that has been referred to as being monolithic.

Immediately next to it for comparison, Figure 5 demonstrates reinforcement strands 8, in optionally a plurality of layers, embedded in a monolithic wall 9. Friction reduction channels 10 and bore surfaces 11 can be shaped selectively with the methods provided by this invention. In this illustration, the bore surfaces 11 are smooth welded flat between friction reduction channels 10.

Reference is made now to Figure 6, which comprises an entire page on its side and reading from left to right. At the top of the sideways page is a layout of a co-extrusion method 16 of this invention. At the bottom of the page are cross sections of stages of production 17 of a catheter 1. The stages of production 17

are referenced to particular steps of the co-extrusion method 16 by phantom lines. The stages of production 17 are production forms of the catheter 1 at the indicated steps of the co-extrusion method 16, subject to variation for different embodiments of the catheter 1 and of the co-extrusion method 16.

5 Starting at the top left corner is a mandrel 18, which is shown in cross section 19 at the bottom of the page. This mandrel 18 is representative of a variety of well-known mandrels and mandrel systems that could be employed with this invention. It is also representative of particular mandrels explained by this invention. Following the mandrel 18 is a first extrusion die 20 which extrudes a
10 first portion of the catheter wall 21. A first wrapper 22 is employed to wrap one or more strands of inside reinforcement 23 onto the outside diameter of the first portion of the catheter wall 21. There can be one or more strands of inside reinforcement 23 which is shown with six strands being wrapped simultaneously. Then a second extrusion die 24 is employed to extrude a second portion of
15 catheter wall 21. The second portion of the wall 21 becomes an indistinguishable, monolithic, fused addition to the catheter wall 21. The form of the catheter after the first extrusion die is a first stage catheter tube 25. It would be useable for some applications but not for the purposes intended by this invention. After wrapping the first stage catheter tube 25 with reinforcement material 23, there
20 is no useable form of catheter because the reinforcement material is exposed in an unacceptable manner for medical purposes. After extrusion by the second extrusion die, however, there is a viable catheter referred to as a second stage catheter tube 26. The second stage catheter tube 26 can be provided with friction reduction channels 10 in accordance with the type of mandrel 18 and related practices being employed. Because the process could be terminated at
25 this point for some embodiments of this invention, a first terminal 27 is illustrated by break lines in the catheter wall 21.

The co-extrusion method 16 can be continued by maintaining molten heat of the catheter wall 21 and employing a second wrapper 28 for adding a second
30 layer of reinforcement material 29 to the catheter wall 21. Then a third extrusion

die 30 is employed to extrude additional molten catheter material in fused relationship to the existing catheter wall 21. The fused molten catheter wall 21 becomes thicker with the additional molten material added and with the additional reinforcement wrapped onto it. After further molten deposit by the third extrusion die 30, a third stage catheter tube 31 is formed. This is a more advanced embodiment of the invention. A second terminal 32 is shown to indicate optional termination of the co-extrusion method at this point. There can be additional wrappers and extrusion dies as long as there is a means for maintaining molten heat sufficient for fusion of the material added to the previous catheter material.

Another desirable co-extrusion step for some applications is to employ a linear positioner 33 to position linear diagnostic, spring or other linear components 34 and then cover them with additional material extruded with a fourth extrusion die 35. This function can be accomplished either before the second wrapper 28 or after the third extrusion die 30. The sequence of the second wrapper 28 and the linear positioner 33 would be reversed. This would cause the second layer of reinforcement material 29 to secure the linear components 34 in the catheter wall 21. When positioned after the third extrusion die 30, linear components 34 can be pressured against the outside of reinforcement material 29 while being covered with additional catheter material to comprise a fourth stage catheter tube 36.

Referring to Figures 7 and 8, an in place mandrel 37 with etched spiral channels 38 and optional opposite direction spiral channels 39 can be employed to form reciprocally spiralled ridges 40 and 41 in a formed channel catheter tube 42. After the in place mandrel 37 is removed by disintegration or other means, ridge peaks 43 form inside walls of the catheter tube 42 with low friction resistance to passage of instrumentation through the bore 12. With solid lubrication in the catheter material, friction resistance is particularly low.

Referring to Figures 9 and 10, a sliding mandrel 44 with rotatable channel forming knob 45 and oppositely rotatable channel forming knob 46 as options can be employed to form inside diameters of catheters 1. The sliding mandrel can be any desired length which does not cause excessive friction. Heat can be added through the mandrel 44 in addition to being added externally. Rotation of the knobs 45 and 46 can be provided through a forward axle 47 having appropriate internal gearing for opposite rotation.

Referring to Figure 11, a heat source 48 at the outside periphery of catheter walls 21 can be employed to cause a molten state of the walls 21 and to cause heat expansion of heat expandable in place mandrel 49. Expansion of the heat expandable mandrel 49 against the molten catheter walls 21 forces the walls 21 to deform outward radially and to form friction reduction channels 10 at sides of inside reinforcement strands 23. A slight increase in outside diameter of the walls 21 can result to compensate for outward travel in the formation of the friction reduction channels 10. Bore surfaces 11 are formed as spiralled ridges between the friction reduction channels 10.

Referring to Figure 12, reinforcement strands 8 can be spiral wrapped and counter spiral wrapped onto the outside periphery of catheter walls 21. The spiral wrapping can be less dense at particular portions, such as at the distal end where a tip is attached.

Referring to Figures 13 and 14, heating of a distal end 5 of the catheter walls 21 to weld on a catheter tip 6 can cause the catheter material to soften and allow ends of reinforcement strands 8 to protrude as illustrated in Figure 13. To avoid this and to cause a reliable weld of a tip 6 to a distal end 5 of a catheter 1, catheter walls 21 are stress relief cut with selective wedge cuts 50 and linear cuts 51. This isolates circumferential pressure of the reinforcement strands 8 from a cut section of a distal end of walls 21.

In Figure 15, a catheter tip 6 that is welded to a distal end 5 of catheter walls 21 shows portions of the tip 6 extended into the linear cuts 50. To accomplish this without melting the matrix of the distal end 5 of the catheter walls 21 and without melting the tip 6, however, requires special methods.

5 Figure 18 shows an iron, or other suitable metal, receptor disk 52 located at some predetermined precise point within a stainless steel welding mandrel 53 for transferring heat to a limited area at the relief cut distal end 5 of the catheter walls 21 and a butt end 54 of the tip 6. Heat is applied, by any suitable means, only at the receptor disk 52 which extends only about one-half of the
10 length of the stress relief cuts 50 and 51 and an approximately equal length of the tip 6 from its butt end 54. This provides a preliminary weld, leaving the other one-half of the relief cuts 55 unwelded. An inside surface weld and an outside surface weld with heat dissipation at opposite surfaces respectively are employed to finish the process of welding the tip 6 to the distal end 5 of the catheter 1.

15 Figure 16 shows the inside surface welding step of welding the tip 6 to the distal end 5 of the walls 21. A welding mandrel 56 is employed to apply heat to a slightly longer length of the walls 21 and the tip 6 at their inside diameter. Simultaneously, heat is dissipated through a cooling sheath 57 or other heat sink in heat conductive relationship to the outside of the walls 21 and the tip 6.

20 Figure 17 shows the outside surface welding step of welding the tip 6 to the distal end 5 of the walls 21. An outside circumferential welder 58 is employed to apply welding heat to the outside peripheries of walls 21 and tip 6 while heat is being dissipated directly by a coolant such as cryogenic nitrogen supplied through a coolant tube 59.

25 Referring to Figure 19, perfusion ports can be constructed in walls 21 with a cutting or punching tool 60 without destroying structural integrity of either the catheter material or reinforcement strands when friction heat from a cutting process is dissipated from the walls 21 adequately. This is accomplished with a

clamp block 61 having coolant channels 62 at each side and a cooling enclosure 63 at the outside periphery of the walls 21 which are positional in a clamp enclosure 64. After flowing in through the coolant channels 62 and around a portion of the walls 21 in the cooling enclosure 63, coolant then passes through a cutting enclosure 65. This directs the coolant lastly in contact with the cutting tool 60.

Referring to Figure 20, reinforcement strands 8 to be wrapped onto a mandrel 18 as either inside reinforcement 23 or second layer reinforcement 29 can be coated with bonding material while being wrapped. This is accomplished by passing the strands 8 through a fluidized powder bed 66 and applying electrostatic charge through a charger 67.

Referring to Figure 21, a series of axial welds or a continuously rotating weld at the outside periphery of walls 21 can be employed to prevent melting of the entire walls at any time. This is accomplished by positioning a welding heat source 68 at a portion of the outside periphery of walls 21. Then the welding heat source 68 is rotated for either a series of axial welds or rotated continuously as indicated by broken line illustrations. Heat can be dissipated through a fluid or solid cooling medium 69 inside of the walls 21.

Referring to Figure 22, reinforcement strands 8 can be wound into lines 70 with multiple strands. The principles applicable are similar to those employed in cable winding because the materials have similar characteristics although the sizes are much smaller. Single strands can be as small in diameter as 0.010 inches, about the size of a human hair. The smaller in diameter, the more flexible a strand can be and still provide strength when there are multiple strands wound together like a cable or yarn. Like cable technology also, a center core 71 can be larger than other strands 72. A wide variety of alternative lines 70 can be provided. The center core can be a glass fiber for fiber optics, a separate catheter lumen or a copper wire for current conductivity, for example.

Referring to Figure 23, all of the reinforcement strands 8 in a uniform strand line 73 can be the same diameter. Either or all of the strands can be of a type to provide some diagnostic function such as light conductance and current conductance for internal television. When used only for resilience to provide high torque transmission, small strands of metal, glass or synthetic material wound into cable are superior to single larger strands. In addition to providing greater strength, resilience and flexibility, they also allow catheter material flow and set between strands. This results in high bonding strength in the ultra thin, high torque walls of catheters constructed in accordance with the teachings of this invention.

Various modifications may be made of the invention without departing from the scope thereof and it is desired, therefore, that only such limitations shall be placed thereon as are imposed by the prior art and which are set forth in the appended claims.

WHAT IS CLAIMED IS:

1. A catheter having:

strands of reinforcement material embedded in monolithic catheter walls of flexible material;

- 5 solid lubricant material on inside and outside peripheral surfaces of the catheter walls; and

friction reduction channels in the inside peripheral surfaces of the catheter walls.

- 10 2. A catheter according to claim 1 wherein the reinforcement material is resilient with a structural memory.

3. A catheter according to claim 2 wherein the reinforcement material is a single strand positioned in the monolithic catheter walls in select helical relationship to linear axis of the catheter.

- 15 4. A catheter according to claim 1 wherein the reinforcement material is a plurality of layers of single resilient strands positioned concentrically with alternately oppositely spiralled strands stacked circumferentially within the monolithic catheter walls.

- 20 5. A catheter according to claim 1 wherein the reinforcement material is a plurality of single resilient strands braided in oppositely spiralled relationship within the monolithic walls.

6. A catheter according to claim 1 wherein the reinforcement material is a multiple strand resilient line positioned in the monolithic catheter walls in select helical relationship to linear axis of the catheter.

5 7. A catheter according to claim 1 wherein the reinforcement material is a plurality of layers of multiple strand resilient lines positioned concentrically with the layers of oppositely spiralled multiple strand resilient lines stacked circumferentially within the monolithic catheter walls.

10 8. A catheter according to claim 1 wherein the reinforcement material is a plurality of multiple strand resilient lines spiral braided in oppositely spiralled relationship within the monolithic walls.

9. A catheter according to claim 1 wherein the reinforcement material is a single strand of resilient material positioned in the monolithic catheter walls in select density of helical spirals per linear distance within the catheter.

15 10. A catheter according to claim 1 wherein the reinforcement material is a plurality of layers of single resilient strands positioned concentrically with alternately oppositely spiralled strands stacked circumferentially within the monolithic catheter walls and having select density of helical spirals per linear distance within the catheter.

20 11. A catheter according to claim 1 wherein the reinforcement material is a plurality of single resilient strands spiral braided in oppositely spiralled relationship within the monolithic walls and having select density of helical spirals per linear distance within the catheter.

12. A catheter according to claim 1 wherein the reinforcement material is a multiple strand resilient line positioned in the monolithic catheter walls in select helical relationship to linear axis of the catheter and having select density of helical spirals per linear distance within the catheter.
- 5 13. A catheter according to claim 1 wherein the reinforcement material is a plurality of layers of multiple strand resilient lines positioned concentrically with alternately oppositely spiralled multiple strand resilient lines stacked circumferentially within the monolithic catheter walls and having select density of helical spirals per linear distance within the catheter.
- 10 14. A catheter according to claim 1 wherein the reinforcement material is a plurality of multiple strand resilient lines braided in oppositely spiralled relationship within the monolithic walls and having select density of helical spirals per linear distance within the catheter.
- 15 15. A catheter according to claim 1 wherein the reinforcement material is a single strand of resilient material positioned in the monolithic catheter walls in select variation of density of helical spirals per linear distance within the catheter.
- 20 16. A catheter according to claim 1 wherein the reinforcement material is a plurality of layers of single resilient strands positioned concentrically with alternately oppositely spiralled strands stacked circumferentially within the monolithic catheter walls and having select variation of density of helical spirals per linear distance within the catheter.

17. A catheter according to claim 1 wherein the reinforcement material is a plurality of single resilient strands spiral braided in oppositely spiralled relationship within the monolithic walls and having select variation of density of helical spirals per linear distance within the catheter.
- 5 18. A catheter according to claim 1 wherein the reinforcement material is a multiple strand resilient line positioned in the monolithic catheter walls in select helical relationship to linear axis of the catheter and having select variation of density of helical spirals per linear distance within the catheter.
- 10 19. A catheter according to claim 1 wherein the reinforcement material is a plurality of layers of multiple strand resilient lines positioned concentrically with alternately oppositely spiralled multiple strand resilient lines stacked circumferentially within the monolithic catheter walls and having select variation of density of helical spirals per linear distance within the catheter.
- 15 20. A catheter according to claim 1 wherein the reinforcement material is a plurality of multiple strand resilient lines braided in oppositely spiralled relationship within the monolithic walls and having select variation of density of helical spirals per linear distance within the catheter.
- 20 21. A catheter according to claim 1 wherein the reinforcement material is select strands of resilient material positioned in select spiralled relationship within the monolithic walls and further comprising:
linear reinforcement members positioned in the monolithic walls.

22. A catheter according to claim 21 wherein the linear reinforcement members are resilient.

23. A catheter according to claim 1 wherein the reinforcement material is select strands of resilient material positioned in select spiralled relationship within the monolithic walls and further comprising:

linear diagnostic communication members positioned in the monolithic walls.

24. A catheter according to claim 23 and further comprising:

linear reinforcement members positioned in the monolithic walls.

25. A catheter according to claim 24 wherein the linear reinforcement members are resilient.

26. A catheter according to claim 1 wherein the reinforcement material is select strands of resilient material positioned in select spiralled relationship within the monolithic walls and further comprising:

at least one perfusion port positioned selectively in a wall of the catheter.

27. A catheter according to claim 1 wherein the reinforcement material is select strands of resilient material positioned in select spiralled relationship within the monolithic walls and further comprising:

at least one stress relief cut in a distal end of the catheter; and

5 a tip welded to the distal end of the catheter.

28. A catheter according to claim 27 wherein density of spirals of the reinforcement material is decreased selectively in proximity of the distal end of the catheter.

29. A catheter according to claim 28 and further comprising:

10 at least one linear member in the monolithic wall proximate the distal end of the catheter.

30. A catheter according to claim 29 wherein the at least one linear member is selectively bendable to provide a bendable tip section of the catheter.

15 31. A catheter according to claim 29 wherein the at least one linear member is selectively resilient and bendable in a desired resilient curve to provide a curved resilient tip of the catheter.

32. A catheter according to claim 1 wherein the solid lubricant is a fluorine containing material.

33. A catheter according to claim 1 wherein the solid lubricant is a polymeric organic silicon material.

34. A catheter according to claim 1 wherein the friction reduction channels are helical voids between catheter material containing solid lubricant on helical reinforcement members at inside peripheral surfaces of the catheter.

35. A catheter according to claim 1 wherein the friction reduction channels are opposite directional helical voids between braided solid lubricant covered opposite directional helical reinforcement members at inside peripheral surfaces of the catheter.

36. A catheter according to claim 1 wherein the friction reduction channels are helical voids in solid lubricant covered catheter material at inside peripheral surfaces of the catheter.

37. A catheter according to claim 1 wherein the friction reduction channels are opposite directional helical voids in solid lubricant covered catheter material at inside peripheral surfaces of the catheter.

38. A method for producing a catheter having strands of reinforcement material embedded in monolithic catheter walls of flexible material; solid lubricant material on inside and outside peripheral surfaces of the catheter walls; and friction reduction channels in the inside peripheral surfaces of the catheter walls; such method comprising a co-extrusion process having the following steps:

25,

sequentially positioning a mandrel, a first extrusion die, a wrapper and a second extrusion die fluidly downstream from a feed hopper and related extrusion machinery;

5

forming a first stage catheter tube on the mandrel at the first extrusion die;

wrapping reinforcement material onto outside peripheral walls of the first stage catheter tube;

forming friction reduction channels in inside walls of the catheter;

10

maintaining select molten state heat of the first stage catheter tube proximate the second extrusion die;

15

co-extruding a second stage catheter tube with the first stage catheter tube by fusing the first stage catheter tube and the second stage catheter tube at select fusion heat level with the reinforcement material embedded in molten catheter material from both the first stage catheter tube and the second stage catheter tube in a monolithic catheter wall formed thereby.

39. A method according to claim 38 and further comprising:

20

positioning at least one channel forming appendage on a first rotatable mandrel member fluidly downstream from a lead portion of the mandrel and rotating the first rotatable mandrel member selectively in one direction of rotation to form a helical friction reduction channel in the inside wall of the catheter as the catheter is being extruded.

40. A method according to claim 39 and further comprising:

5 positioning at least one channel forming appendage on a second rotatable mandrel member fluidly downstream from the first rotatable mandrel member and rotating the second rotatable mandrel member selectively in an opposite direction of rotation from the first rotatable mandrel member to form opposite directional helical friction reduction channels in the inside wall of the catheter as the catheter is being co-extruded.

10 41. A method according to claim 38 wherein wrapping reinforcement material is select helical wrapping of select resilient strands onto outside peripheral walls of the first stage catheter tube.

42. A method according to claim 38 wherein wrapping reinforcement material onto outside peripheral walls of the first stage catheter tube is braid wrapping of reinforcement strands in opposite directional helical coils.

15 43. A method according to claim 38 wherein the friction reduction channels are formed by stressing the reinforcement strands inward radially while maintaining select heat in the catheter wall and enlarging effective diameter of the mandrel such that friction reduction channels are formed between reinforcement material that is thinly coated with catheter material and solid lubricant as the
20 catheter is being co-extruded.

44. A method according to claim 38 and further comprising:

sequentially positioning a second wrapper and a third extrusion die fluidly downstream from the second extrusion die;

5

wrapping a select second reinforcement member selectively onto outside peripheral walls of the second stage catheter with the second wrapper;

maintaining select molten state heat of the second stage catheter tube proximate the third extrusion die;

10

co-extruding a third stage catheter tube and the second stage catheter tube by fusing the second stage catheter tube and the third stage catheter tube at a select fusion heat level with the second reinforcement material embedded in molten catheter material of both the second stage catheter tube and the third stage catheter tube in a monolithic catheter wall formed thereby.

15

45. A method according to claim 38 wherein the reinforcement material is a reinforcing fiber and further comprising:

passing the fiber through a select fluidized powder bed in which the fiber is coated with the fluidized powder by means of an electrostatic charge;

20

applying the coated fiber onto the mandrel; and

fusing the coating of the fiber into a catheter wall by means of an external heat source to form a monolithic catheter while the fiber is being applied.

46. A method according to claim 38 and further comprising:

positioning a linear material insertion member fluidly downstream from a
last extrusion die following a last wrapper;

5 positioning a linear material cover extrusion die downstream from the
linear material insertion member;

positioning select linear material on the outside periphery of a last stage
catheter; and

10 co-extruding a linear material cover of catheter material onto the last
stage catheter while maintaining a select molten state heat of the
last stage catheter.

47. A method according to claim 38 and further comprising:

axially stress relief cutting a distal end of a catheter selectively linearly; and

welding a catheter tip to the distal end of the catheter.

48. A method according to claim 38 and further comprising:

15 axially cutting a distal end of a catheter with selective linear stress relief
cuts;

butting a pre-cut end of the catheter tip concentrically against a stress
relief cut distal end of the catheter on a supporting mandrel;

applying welding heat to a select end portion of the stress relief cut distal end of the catheter and to a select end portion of the end of the catheter tip that is butted against the distal end of the catheter;

5 applying abutment pressure to the catheter tip against the distal end of the catheter while the welding heat is being applied to cause molten material of the catheter tip to flow into stress relief cuts in the distal end of the catheter;

10 preventing melt level heat from penetrating beyond the stress relief cuts in the catheter and beyond a select welding distance in the catheter tip; and

smooth welding interior and exterior surfaces of a weld section of the distal end of the catheter and catheter tip.

15 49. A method according to claim 48 wherein inside peripheral welding of the catheter tip to the distal end of the catheter is accomplished by applying welding heat through a mandrel at the inside periphery of the distal end of the catheter and the pre-cut end of the catheter tip while heat is being dissipated through a cooling medium at the outside periphery of the distal end of the catheter and the pre-cut end of the catheter tip.

20 50. A method according to claim 48 wherein outside peripheral welding of the catheter tip to the distal end of the catheter is accomplished by applying welding heat to a sheath at the outside periphery of the distal end of the catheter and of the pre-cut end of the catheter tip while heat is being dissipated through a cooling medium being passed through the inside of the catheter and through the inside of the catheter tip.

51. A method according to claim 48 wherein a series of axial welds are performed to prevent destruction of a matrix of the catheter and catheter tip from heat when being welded together, such series of axial welds being accomplished by applying welding heat to select outside peripheral portions of the catheter and catheter tip while passing a cooling medium through an inside lumen of the catheter and catheter tip and then applying heat to different outside peripheral portions of the catheter and catheter tip while passing a cooling medium through the inside lumen of the catheter and catheter tip repeatedly until the entire circumferential surface of the catheter and the catheter tip have been welded together without at any time melting an entire circumferential portion of the catheter and catheter tip being welded.

52. A method according to claim 48 and further comprising:

affixing an iron receptor disk to a distal end of a hollow mandrel made of stainless steel;

15 positioning the iron receptor disk proximate an inside peripheral portion of the distal end of the catheter and catheter tip to be welded;

applying select radio frequency current to the iron receptor disk; and

dissipating heat from the outside periphery of the catheter and catheter tip.

53. A method according to claim 38 and further comprising:

5 milling at least one perfusion port in a wall of the catheter while passing a cryogenic fluid about exterior peripheral surfaces of a select portion of the catheter being milled and about a cutter tool with which the at least one perfusion port is being milled.

54. A method according to claim 53 wherein the cryogenic fluid is passed through an aperture in a clamp block in which the catheter is being held, through an adjoining aperture at an outside peripheral surface of a portion of the catheter being milled and through a further adjoining aperture through which the cutter tool is being inserted for milling the at least one perfusion port.

10

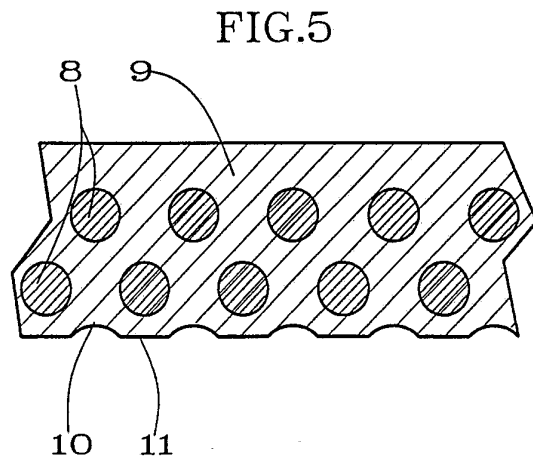
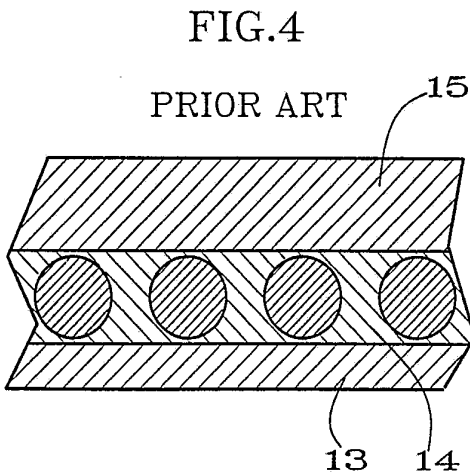
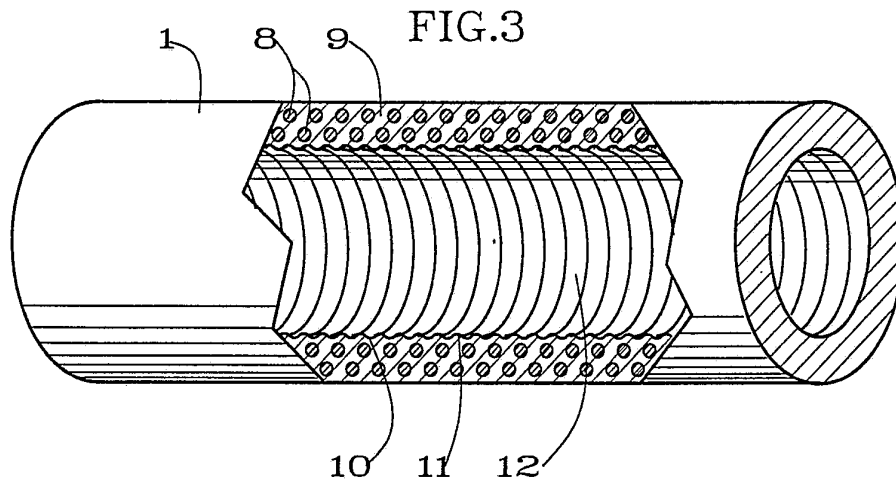
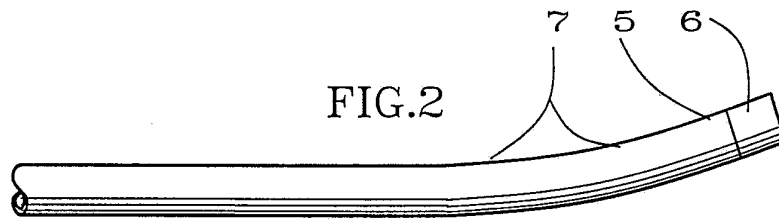
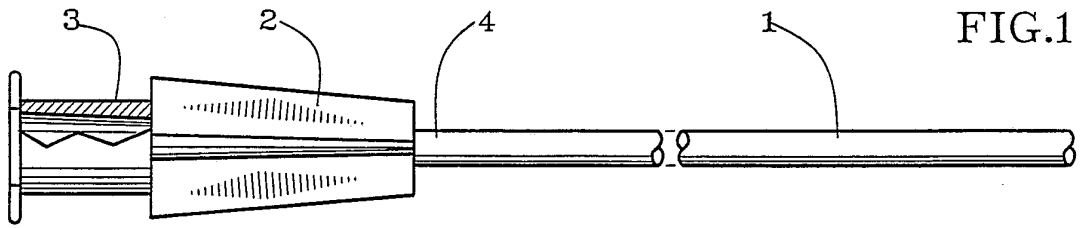

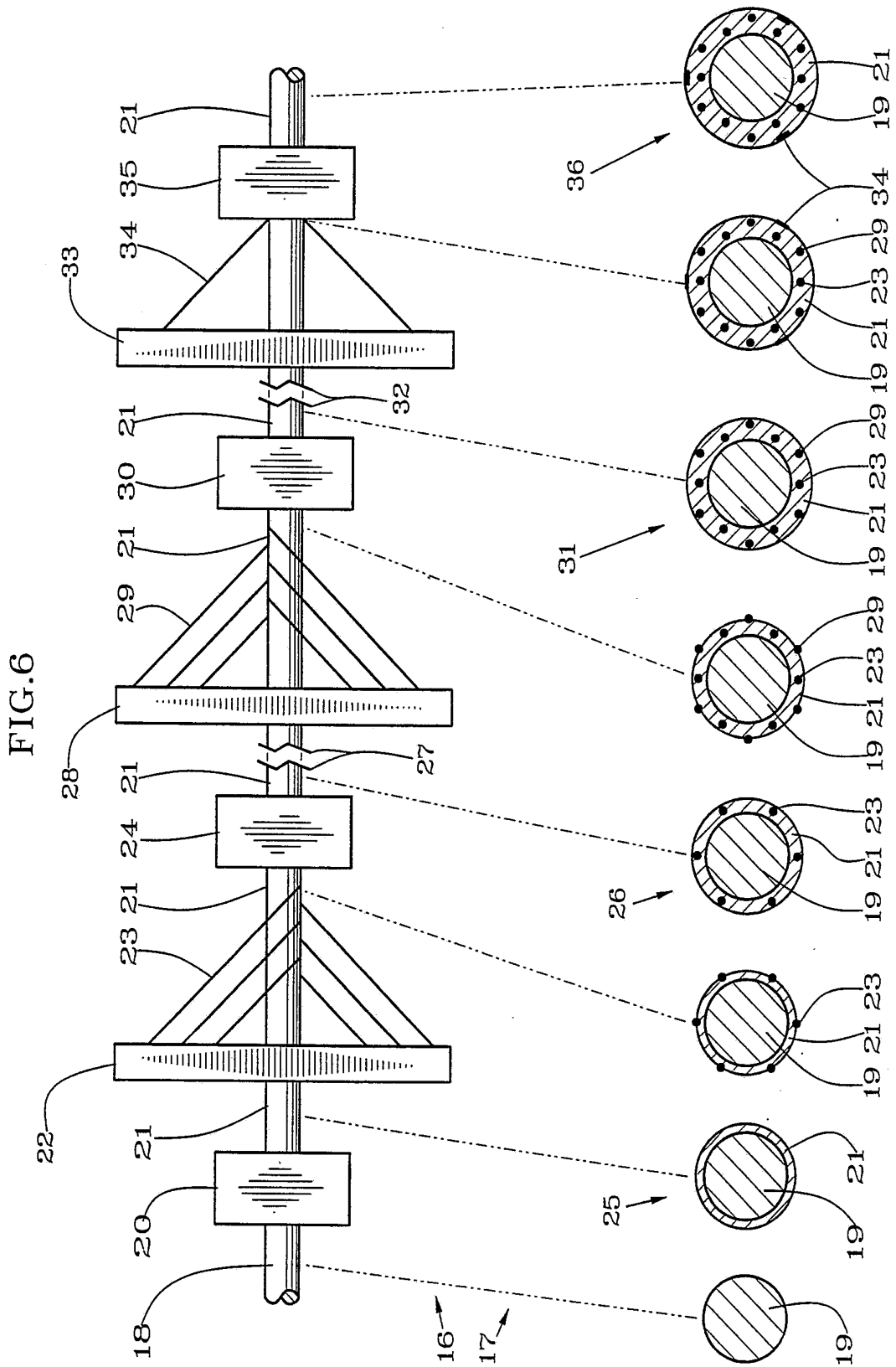

FIG.7

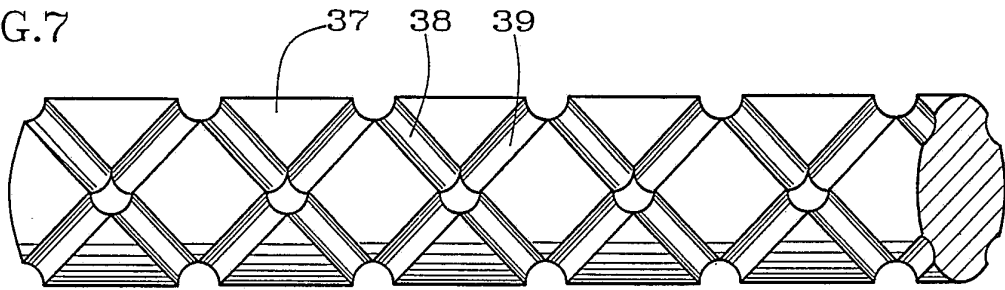

FIG.8

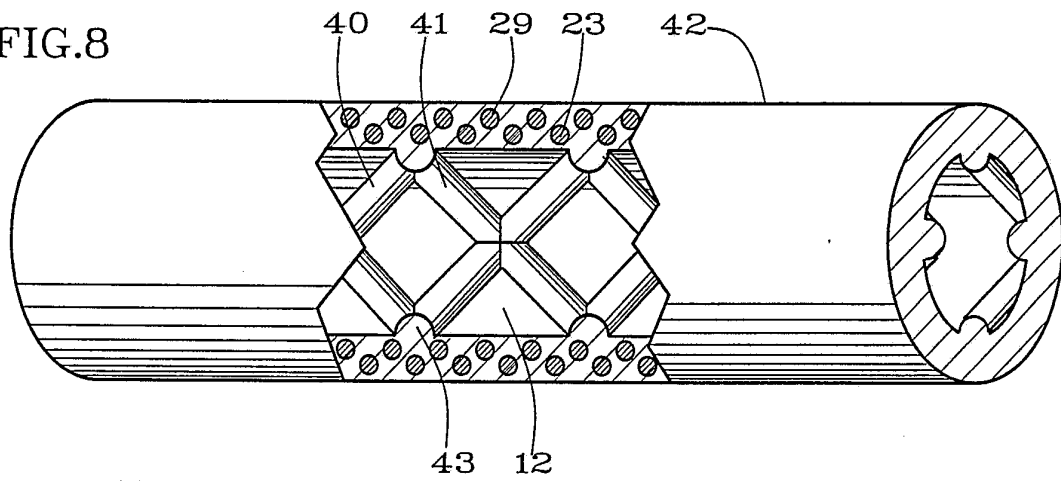

FIG.9

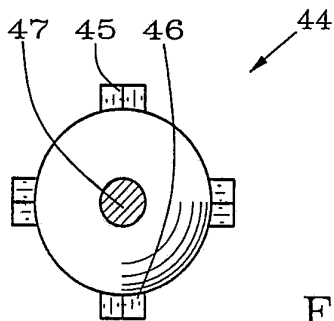
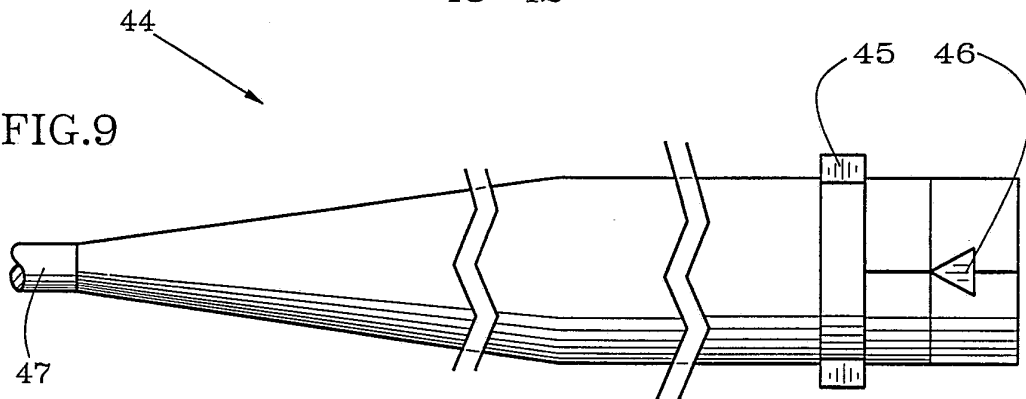

FIG.10

FIG.11

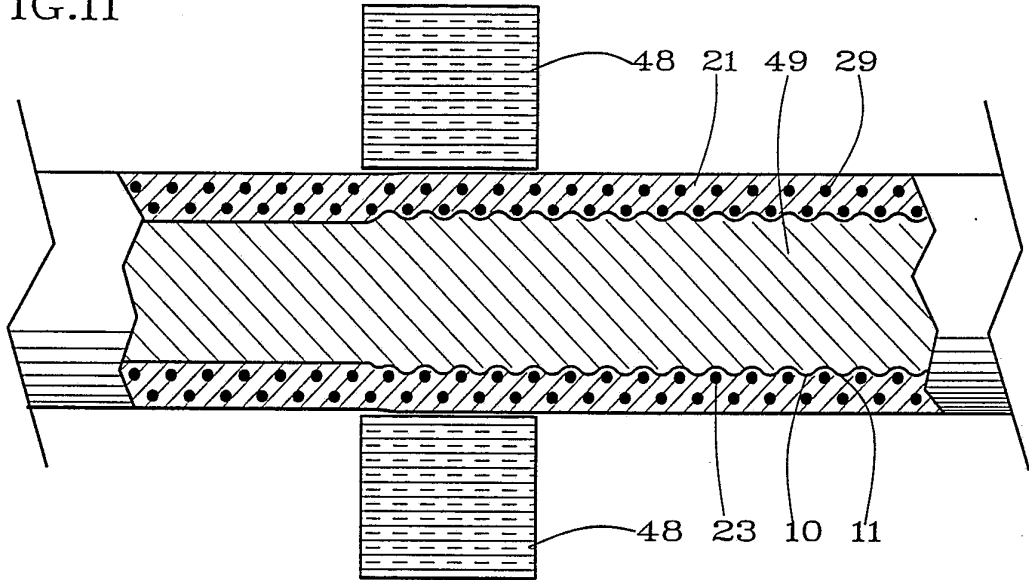

FIG.12

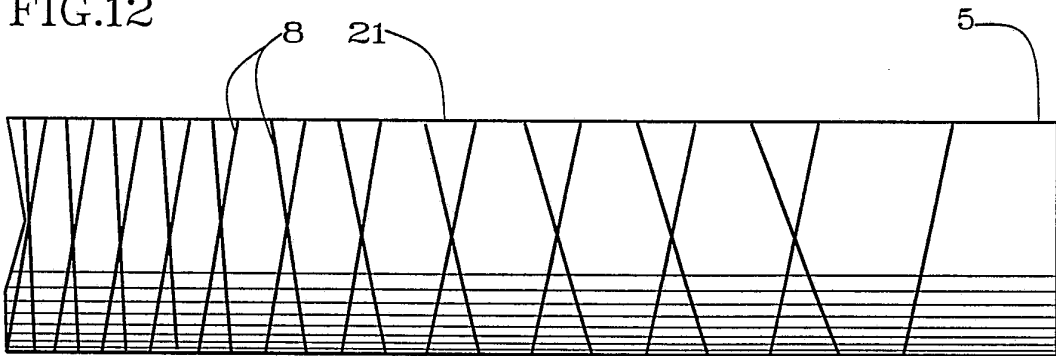

FIG.13

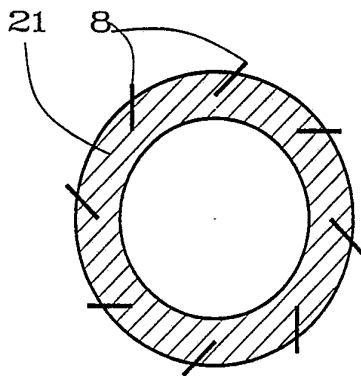

FIG.14

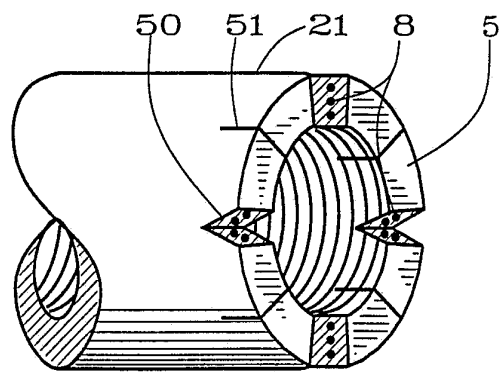

FIG.15

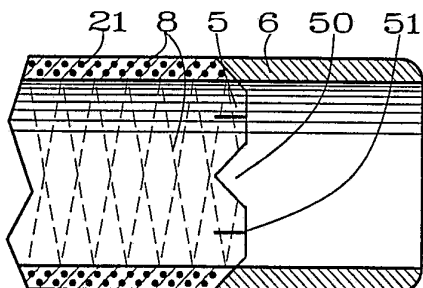

FIG.18

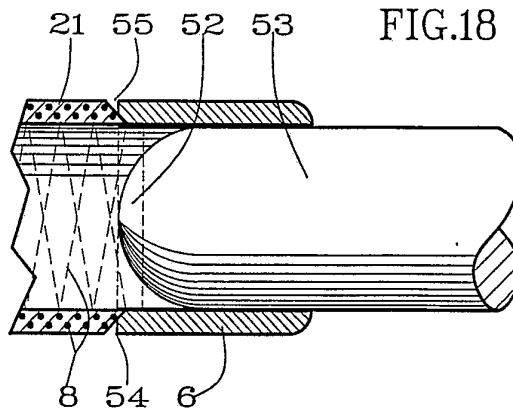

FIG.16

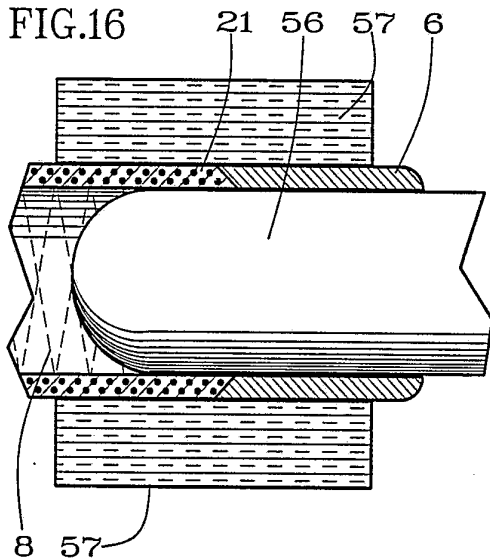

FIG.17

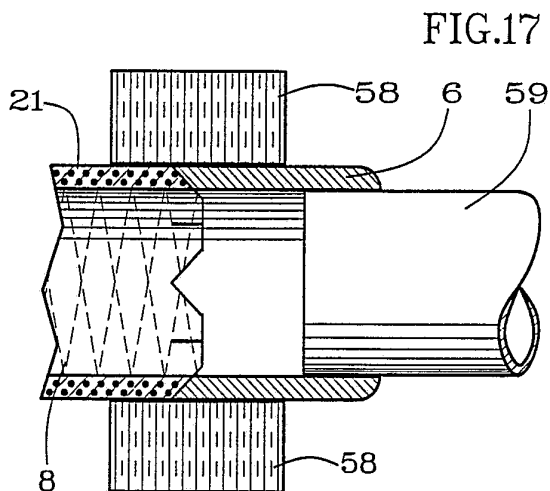
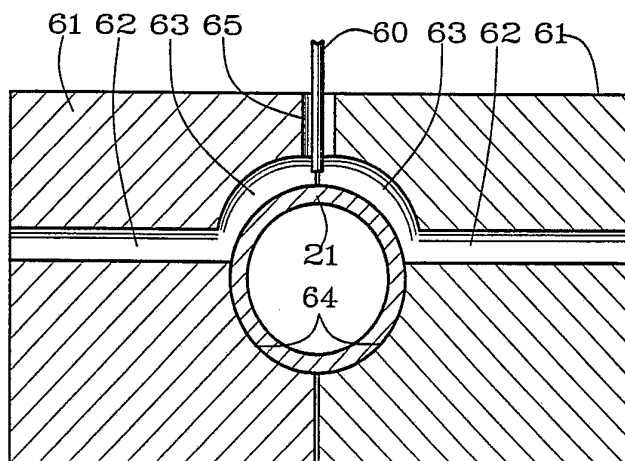

FIG.19



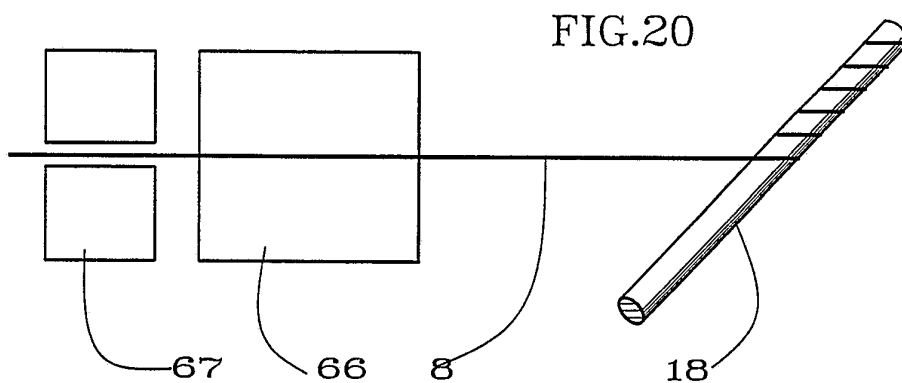
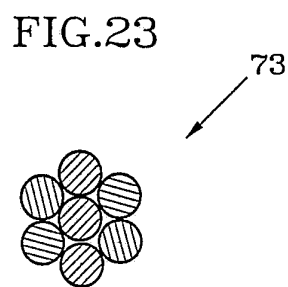
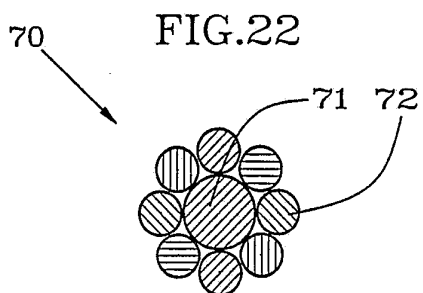
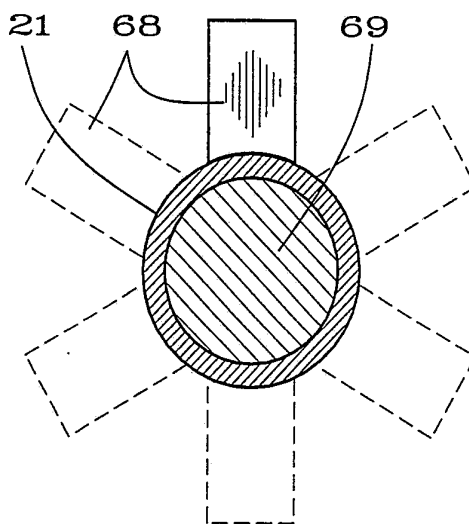

FIG.21



INTERNATIONAL SEARCH REPORT

International application No.
PCT/US93/04370

A. CLASSIFICATION OF SUBJECT MATTER

IPC(5) : A61M 25/00; B28B 3/20; B29C 47/00
US CL : 604/282; 264/176.1

According to International Patent Classification (IPC) or to both national classification and IPC

B. FIELDS SEARCHED

Minimum documentation searched (classification system followed by classification symbols)

U.S. : 604/282; 264/176.1, 264, 280, 281, 265

Documentation searched other than minimum documentation to the extent that such documents are included in the fields searched

Electronic data base consulted during the international search (name of data base and, where practicable, search terms used)

C. DOCUMENTS CONSIDERED TO BE RELEVANT

Category*	Citation of document, with indication, where appropriate, of the relevant passages	Relevant to claim No.
X - Y	US, A, 4,705,511 (Kocak) 10 November 1982, see figures 1 and 2.	1-3, 9, 15, 32, 34 and 36 ----- -- 4-8, 10-14, 16-28, 33
Y	US, A, 3,416,531 (Edwards) 17 December 1968, see entire document.	4, 5, 9-11, 15-17, 26, 27 and 33
Y	US, A, 2,268,321 (Flynn) 30 December 1941, see entire document.	6, 7, 8, 12-14, and 18-22

Further documents are listed in the continuation of Box C. See patent family annex.

<p>* Special categories of cited documents:</p> <p>"A" document defining the general state of the art which is not considered to be part of particular relevance</p> <p>"E" earlier document published on or after the international filing date</p> <p>"L" document which may throw doubts on priority claim(s) or which is cited to establish the publication date of another citation or other special reason (as specified)</p> <p>"O" document referring to an oral disclosure, use, exhibition or other means</p> <p>"P" document published prior to the international filing date but later than the priority date claimed</p>	<p>"T" later document published after the international filing date or priority date and not in conflict with the application but cited to understand the principle or theory underlying the invention</p> <p>"X" document of particular relevance; the claimed invention cannot be considered novel or cannot be considered to involve an inventive step when the document is taken alone</p> <p>"Y" document of particular relevance; the claimed invention cannot be considered to involve an inventive step when the document is combined with one or more other such documents, such combination being obvious to a person skilled in the art</p> <p>"&" document member of the same patent family</p>
---	---

Date of the actual completion of the international search
26 July 1993

Date of mailing of the international search report

24 SEP 1993

Name and mailing address of the ISA/US
Commissioner of Patents and Trademarks
Box PCT
Washington, D.C. 20231

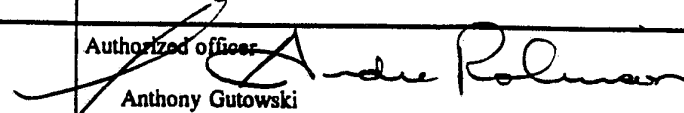
Authorized officer 
Anthony Gutowski

Facsimile No. NOT APPLICABLE

Telephone No. (703) 308-2980

INTERNATIONAL SEARCH REPORT

International application No.
PCT/US93/04370

C (Continuation). DOCUMENTS CONSIDERED TO BE RELEVANT

Category*	Citation of document, with indication, where appropriate, of the relevant passages	Relevant to claim No.
Y	US, A, 5,057,092 (Webster, Jr.) 15 October 1991, see entire document.	5, 11, 17, 21 and 22
Y	US, A, 3,498,286 (Polanyi et al.) 03 March 1970, see entire document.	23-25
Y	US, A, 5,037,404 (Gold et al.) 06 August 1991, see entire document.	28
Y	US, A, 3,890,976 (Bazell et al.) 24 June 1975, see figure 12.	27