

(19) World Intellectual Property Organization
International Bureau



(43) International Publication Date
7 December 2000 (07.12.2000)

PCT

(10) International Publication Number
WO 00/74260 A1

- (51) International Patent Classification⁷: **H04B 7/005** Holstlaan 6, NL-5656 AA Eindhoven (NL). **BAKER, Matthew, P., J.**; Prof. Holstlaan 6, NL-5656 AA Eindhoven (NL).
- (21) International Application Number: PCT/EP00/04217
- (22) International Filing Date: 8 May 2000 (08.05.2000) (74) Agent: **TANGENA, Antonius, G.**; Internationaal Octrooibureau B.V., Prof. Holstlaan 6, NL-5656 AA Eindhoven (NL).
- (25) Filing Language: English
- (26) Publication Language: English (81) Designated States (national): CN, IN, JP, KR.
- (30) Priority Data: (84) Designated States (regional): European patent (AT, BE, CH, CY, DE, DK, ES, FI, FR, GB, GR, IE, IT, LU, MC, NL, PT, SE).
9912289.7 26 May 1999 (26.05.1999) GB
9915571.5 2 July 1999 (02.07.1999) GB
- (71) Applicant: **KONINKLIJKE PHILIPS ELECTRONICS N.V.** [NL/NL]; Groenewoudseweg 1, NL-5621 BA Eindhoven (NL). **Published:**
— With international search report.
- (72) Inventors: **MOULSLEY, Timothy, J.**; Prof. Holstlaan 6, NL-5656 AA Eindhoven (NL). **HUNT, Bernard**; Prof.

For two-letter codes and other abbreviations, refer to the "Guidance Notes on Codes and Abbreviations" appearing at the beginning of each regular issue of the PCT Gazette.

(54) Title: CLOSED LOOP POWER CONTROL IN A RADIO COMMUNICATION SYSTEM

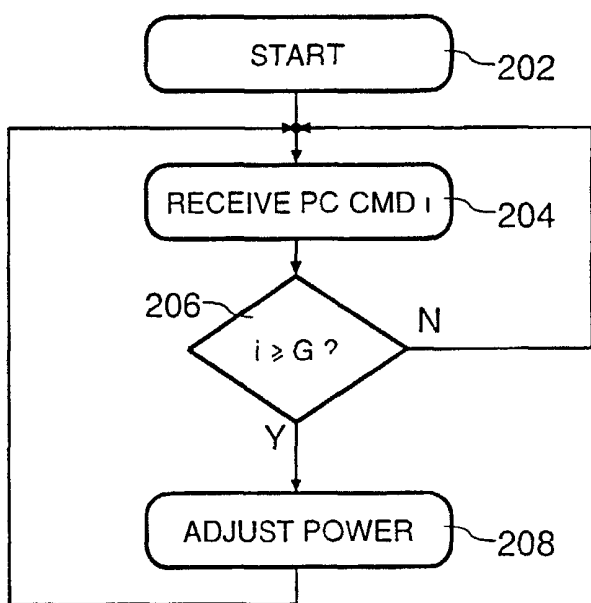

(57) Abstract: In a radio communication system having a primary station and a plurality of secondary stations, the power of uplink and downlink channels between the primary station and a secondary station is controlled in a closed loop manner by each station transmitting power control commands to the other station. In response to these commands the receiving station adjusts its output power in steps. By combining a plurality of received power control commands before adjusting its output power the receiving station may emulate the ability to use a smaller power control step size than its minimum, thereby improving performance under certain channel conditions. In one embodiment when the required power control step size is less than the minimum step size of a particular station, that station processes a group of power control commands to determine whether to adjust its output power by its minimum step size. In an alternative embodiment the power control step size is fixed when the combining algorithm is used. The invention is applicable to power control in both primary and secondary stations.



WO 00/74260 A1

DESCRIPTION
**CLOSED LOOP POWER CONTROL IN A RADIO COMMUNICATION
SYSTEM**

5 Technical Field

The present invention relates to a radio communication system and further relates to a secondary station for use in such a system and to a method of operating such a system. While the present specification describes a system with particular reference to the emerging Universal Mobile Telecommunication
10 System (UMTS), it is to be understood that such techniques are equally applicable to use in other mobile radio systems.

Background Art

There are two basic types of communication required between a Base Station (BS) and a Mobile Station (MS) in a radio communication system. The
15 first is user traffic, for example speech or packet data. The second is control information, required to set and monitor various parameters of the transmission channel to enable the BS and MS to exchange the required user traffic.

In many communication systems one of the functions of the control
20 information is to enable power control. Power control of signals transmitted to the BS from a MS is required so that the BS receives signals from different MS at approximately the same power level, while minimising the transmission power required by each MS. Power control of signals transmitted by the BS to a MS is required so that the MS receives signals from the BS with a low error
25 rate while minimising transmission power, to reduce interference with other cells and radio systems. In a two-way radio communication system power control may be operated in a closed or open loop manner. In a closed loop system the MS determines the required changes in the power of transmissions from the BS and signals these changes to the BS, and vice versa. In an open
30 loop system, which may be used in a TDD system, the MS measures the received signal from the BS and uses this measurement to determine the required changes in the transmission power.

An example of a combined time and frequency division multiple access system employing power control is the Global System for Mobile communication (GSM), where the transmission power of both BS and MS transmitters is controlled in steps of 2dB. Similarly, implementation of power control in a system employing spread spectrum Code Division Multiple Access (CDMA) techniques is disclosed in US-A-5 056 109.

In considering closed loop power control it can be shown that for any given channel conditions there is an optimum power control step size which minimises the required E_b/N_0 (energy per bit / noise density). When the channel changes very slowly the optimum step size can be less than 1dB, since such values are sufficient to track changes in the channel while giving minimal tracking error. As the Doppler frequency increases, larger step sizes give better performance, with optimum values reaching more than 2dB. However, as the Doppler frequency is further increased there comes a point where the latency (or update rate) of the power control loop becomes too great to track the channel properly and the optimum step size reduces again, perhaps to less than 0.5dB. This is because the fast channel changes cannot be tracked so all that is needed is the ability to follow shadowing, which is typically a slow process.

Because the optimum power control step size can change dynamically it may improve performance if the BS instructs the MS which value of power control step size it should use in uplink transmissions to the BS. An example of a system which may use such a method is the UMTS Frequency Division Duplex (FDD) standard, where power control is important because of the use of CDMA techniques. Although improved performance can be obtained by having a small minimum step size, for example 0.25dB, this will significantly increase the cost of a MS. However, if a MS does not have to implement the minimum step size then it may not be able to implement the step size requested by the BS.

Disclosure of Invention

An object of the present invention is to enable accurate power control without requiring all mobile stations to implement the same minimum power control step size.

According to a first aspect of the present invention there is provided a
5 radio communication system comprising a primary station and a plurality of secondary stations, the system having a communication channel between the primary station and a secondary station, one of the primary and secondary stations (the transmitting station) having means for transmitting power control
10 commands to the other station (the receiving station) to instruct it to adjust its output transmission power in steps, wherein the receiving station has combining means for processing a plurality of power control commands to determine whether to adjust its output power.

According to a second aspect of the present invention there is provided a primary station for use in a radio communication system having a
15 communication channel between the primary station and a secondary station, the primary station having means for adjusting its output transmission power in steps in response to power control commands transmitted by the secondary station, wherein combining means are provided for processing a plurality of power control commands to determine whether to adjust its output power.

According to a third aspect of the present invention there is provided a
20 secondary station for use in a radio communication system having a communication channel between the secondary station and a primary station, the secondary station having means for adjusting its transmission power in steps in response to power control commands transmitted by the primary
25 station, wherein combining means are provided for processing a plurality of power control commands to determine whether to adjust its output power.

According to a fourth aspect of the present invention there is provided a method of operating a radio communication system comprising a primary
30 station and a plurality of secondary stations, the system having a communication channel between the primary station and a secondary station, the method comprising one of the primary and secondary stations (the transmitting station) transmitting power control commands to the other station

(the receiving station) to instruct it to adjust its power in steps, wherein the receiving station processes a plurality of power control commands to determine whether to adjust its output transmission power.

The present invention is based upon the recognition, not present in the prior art, that emulation of small power control step sizes by a MS can provide good performance.

Brief Description of Drawings

Embodiments of the present invention will now be described, by way of example, with reference to the accompanying drawings, wherein:

Figure 1 is a block schematic diagram of a radio communication system;

Figure 2 is a flow chart illustrating a method in accordance with the present invention for performing power control in a secondary station;

Figure 3 is a graph of the received E_b/N_0 in dB required for a bit error rate of 0.01 against the power control step size used in dB for a MS moving at 300 km per hour; and

Figure 4 is a graph of the received E_b/N_0 in dB required for a bit error rate of 0.01 against the power control step size used in dB for a MS moving at 1 km per hour.

Modes for Carrying Out the Invention

Referring to Figure 1, a radio communication system which can operate in a frequency division duplex or time division duplex mode comprises a primary station (BS) 100 and a plurality of secondary stations (MS) 110. The BS 100 comprises a microcontroller (μ C) 102, transceiver means (Tx/Rx) 104 connected to radio transmission means 106, power control means (PC) 107 for altering the transmitted power level, and connection means 108 for connection to the PSTN or other suitable network. Each MS 110 comprises a microcontroller (μ C) 112, transceiver means (Tx/Rx) 114 connected to radio transmission means 116, and power control means (PC) 118 for altering the transmitted power level. Communication from BS 100 to MS 110 takes place on a downlink channel 122, while communication from MS 110 to BS 100 takes place on an uplink channel 124.

In a UMTS FDD system data is transmitted in 10ms frames each having 15 time slots. The BS 100 transmits one power control command (consisting of two bits) per slot, where bits 11 (referred to hereinafter for simplicity as a value of 1) requests the MS 110 to increase its power and bits 00 (referred to hereinafter as 0) requests the MS 110 to decrease its power. Changes in the required power control step size are notified separately over a control channel.

In a system according to the present invention this behaviour is modified when the MS 110 is requested to implement a power control step size smaller than the smallest of which it is capable. In this situation the MS 110 takes no action unless it receives a series of identical power control commands, thereby emulating the performance of a MS 110 having more precise power control.

Consider for example the case where the requested step size is 0.5dB and the minimum step size implemented by the MS 110 is 1dB. The MS 110 processes power control commands in pairs and only changes its output power if both commands are equal. Hence if the received commands are 11 the power is increased, if they are 00 the power is decreased, and if they are either 10 or 01 the power is not changed. It is advantageous to align the comparison with the transmission of frames, hence to combine the power control commands transmitted in slots 1 and 2 of a frame, then the commands transmitted in slots 3 and 4, and so on.

Similarly, if the requested step size is 0.25dB and the minimum step size is 1dB the MS 110 processes power control commands four at a time, and only changes its output power if all four commands are equal. Hence the power is increased if the received commands are 1111, decreased if they are 0000, and unchanged otherwise. Again it is advantageous to align the comparison with the frame transmission, combining the commands transmitted in slots 1 to 4, then the commands transmitted in slots 5 to 8 and so on.

Combining the commands received in three or five slots is particularly advantageous in the UMTS embodiment being considered because it maintains alignment with a frame of 15 slots. However, the method is not restricted to such a system. Consider a general case where the minimum step

size implemented by the MS 110 is S and the step size requested by the BS 100 is R . In this case the power control commands may be combined in groups of G , where $G=S/R$.

Figure 2 illustrates a method of emulating smaller power control steps than the minimum of the MS 110. The method starts, at 202, with the MS 110 determining G , the number of commands to be combined in a group and setting a received power control command counter i to zero. At 204 the MS 110 receives a power control command and increments the counter i . Next, at 206, the value of i is compared with G . If i is less than G then the received command is stored and the MS 110 waits to receive the next command. Otherwise the required number of power control commands have been received and the MS 110 determines, at 208, if it should adjust its power based on the received power control commands. Once this has been done the counter i is reset to zero (if i is equal to G) or to one (if i is greater than G , which will happen if G is not integer) and the MS 110 waits to receive the next power control command.

In an alternative embodiment, instead of combining power control commands in groups of G the MS 110 keeps a running total of the requested power change and makes a change once the total requested power change reaches its minimum step size. For example, if the requested step size is 0.25dB and the minimum step size is 1dB the sequence of received commands 11010111 would result in the power being increased by 1dB. The MS 110 then subtracts the step actually implemented from the running total of the requested power change. However, such a scheme is more complex to implement (since it requires maintaining a running total of the requested power change) and it appears to provide only a minimal improvement to the performance of the method.

In a variation of this alternative embodiment, the MS 110 uses a soft decision method in keeping a running total of the requested power change, instead of taking a hard decision on each individual power control command. Each power control command is weighted by a function of the amplitude of the received signal for that command, as a measure of the likelihood of the MS

110 having correctly interpreted the command, before being added to the running sum. For example, the sequence 11010111011 might, once weighted, correspond to the sequence of requested power changes 0.8 0.3 -0.3 0.4 -0.1 0.5 0.9 0.8 -0.4 0.7 0.5 (in units of 0.25dB). This sequence has a running sum
5 of 4.1 which would trigger the MS 110 to execute an upwards step of 1dB and to reduce the running sum to 0.1. This variation should provide a slight improvement in the performance of the method.

Two simulations have been carried out to illustrate the effectiveness of the method according to the present invention. These examine the
10 performance of a MS 110 having a minimum step size of 1dB compared with that of a MS 110 having a minimum step size of 0.25dB. The simulations make a number of idealising assumptions:

- there is a 1 slot delay in the power control loop;
- there is no channel coding;
- 15 • there is perfect channel estimation by the receiver;
- equalisation in the receiver is carried out by a perfect RAKE receiver;
- no control channel overhead is included in the E_b/N_0 figures;
- there is a fixed error rate in the transmission of power control commands; and
- 20 • the channel is modelled as a simple N-path Rayleigh channel.

The first simulation relates to a rapidly changing channel, with a MS 110 moving at 300km per hour in a single path Rayleigh channel with an error rate for the power control commands of 0.01. Figure 3 is a graph of the received E_b/N_0 in dB required for an uplink bit error rate of 0.01 against the power
25 control step size used in dB. The solid line indicates results for a MS 110 having a minimum power control step size of 0.25dB or less, while the dashed line indicates results for a MS 110 having a minimum step size of 1dB which combines power control bits in groups of two or four to emulate 0.5dB and 0.25 dB power control step sizes respectively.

30 In this situation the best performance is obtained for small step sizes of less than 1dB. Emulation of 0.25dB and 0.5dB steps results in a small implementation loss of only about 0.05dB, compared to about 0.6dB if no

emulation is performed, demonstrating the usefulness of the emulation method. Increasing the error rate of the power control commands to 0.1 produces a general degradation of about 0.2dB in the received E_b/N_0 , but the performance of the MS 110 with emulated small steps remains close to that of the MS 110 with direct implementation of small steps.

The second simulation relates to a slowly changing channel, with a MS 110 moving at 1km per hour in a six path Rayleigh channel with a error rate for the power control commands of 0.01. Figure 4 is a graph of received E_b/N_0 in dB required for a uplink bit error rate of 0.01 against the power control step size used in dB. The lines in the graph are identified in the same way as for Figure 3.

In this situation there is a small advantage in using power control steps of less than 1dB. As with the first simulation, the results obtained using emulated small steps are very close to those with direct implementation of small steps.

In a further application of this method the value of G may be set to a value other than S/R if it is considered to be advantageous for reasons such as reducing the effect of errors in the interpretation of the transmitted power control commands (for example by averaging over a greater time period). In some circumstances a MS 110 might therefore choose to use a step size larger than the minimum which it is capable of implementing.

The detailed description above relates to a system where the BS 100 transmits power control commands separately from instructions to the MS 110 to set its power control step size. However, the present invention is suited for use in a range of other systems. In particular, it can be used in any system in which there is a variable power control step size and in which the BS 100 instructs the MS 110 to use a particular value for this step. It can also be used in systems in which the power control step size is fixed, or at least fixed while a power control step size emulation method is being used. Instead of the BS 100 instructing the MS 110 to use a particular step size, that to be used could also be determined by negotiation between the BS 100 and MS 110.

Further, although the description above relates to emulation of power control step sizes by a MS 110, such a method could equally well be employed in a BS 100 for controlling the power of the downlink transmission.

5 From reading the present disclosure, other modifications will be apparent to persons skilled in the art. Such modifications may involve other features which are already known in radio communication systems, and which may be used instead of or in addition to features already described herein.

10 In the present specification and claims the word "a" or "an" preceding an element does not exclude the presence of a plurality of such elements. Further, the word "comprising" does not exclude the presence of other elements or steps than those listed.

Industrial Applicability

The present invention is applicable to a range of radio communication systems, for example UMTS.

CLAIMS

1. A radio communication system comprising a primary station and
5 a plurality of secondary stations, the system having a communication channel
between the primary station and a secondary station, one of the primary and
secondary stations (the transmitting station) having means for transmitting
power control commands to the other station (the receiving station) to instruct
10 it to adjust its output transmission power in steps, wherein the receiving station
has combining means for processing a plurality of power control commands to
determine whether to adjust its output power.

2. A primary station for use in a radio communication system having
a communication channel between the primary station and a secondary
15 station, the primary station having means for adjusting its output transmission
power in steps in response to power control commands transmitted by the
secondary station, wherein combining means are provided for processing a
plurality of power control commands to determine whether to adjust its output
power.

20 3. A secondary station for use in a radio communication system
having a communication channel between the secondary station and a primary
station, the secondary station having means for adjusting its transmission
power in steps in response to power control commands transmitted by the
25 primary station, wherein combining means are provided for processing a
plurality of power control commands to determine whether to adjust its output
power.

30 4. A secondary station as claimed in claim 3, characterised in that
means are provided for selecting one of a plurality of available power control
step sizes in response to commands issued by the primary station, and in that

the combining means are operative if the required step size is less than its minimum available step size.

5 5. A secondary station as claimed in claim 4, characterised in that means are provided for processing a group of power control commands together, the size of the group being determined by the minimum available step size and the required step size.

10 6. A secondary station as claimed in claim 5, characterised in that the size of the group is equal to the ratio between the minimum available step size and the required step size.

15 7. A secondary station as claimed in claim 3, characterised in that the combining means are operative in response to commands issued by the primary station to process a group of power control commands together and in that the size of the group is predetermined.

20 8. A secondary station as claimed in claim 7, characterised in that the power control step size is predetermined.

25 9. A method of operating a radio communication system comprising a primary station and a plurality of secondary stations, the system having a communication channel between the primary station and a secondary station, the method comprising one of the primary and secondary stations (the transmitting station) transmitting power control commands to the other station (the receiving station) to instruct it to adjust its power in steps, wherein the receiving station processes a plurality of power control commands to determine whether to adjust its output transmission power.

30 10. A method as claimed in claim 9, characterised by the transmitting station instructing the receiving station to use a particular power control step

size, and by the receiving station combining power control commands if the required step size is less than the minimum available step size.

5 11. A method as claimed in claim 10, characterised by the receiving station processing a group of power control commands together, and determining the size of the group depending on the minimum available step size and the required step size.

10 12. A method as claimed in claim 11, characterised by the size of the group being equal to the ratio between the minimum available step size and the required step size.

15 13. A method as claimed in claim 9, characterised by the receiving station processing a group of power control commands together in response to commands issued by the transmitting station and by the size of the group being predetermined.

20 14. A method as claimed in claim 13, characterised by the power control step size being predetermined.

25 15. A method as claimed in any one of claims 9 to 14, characterised by transmissions on the channel taking place in frames and by the groups of power control commands having predetermined positions with respect to the start of each frame.

16. A method as claimed in claim 15, characterised by the size of the group being exactly divisible into the number of power control commands transmitted in a frame.

1/2

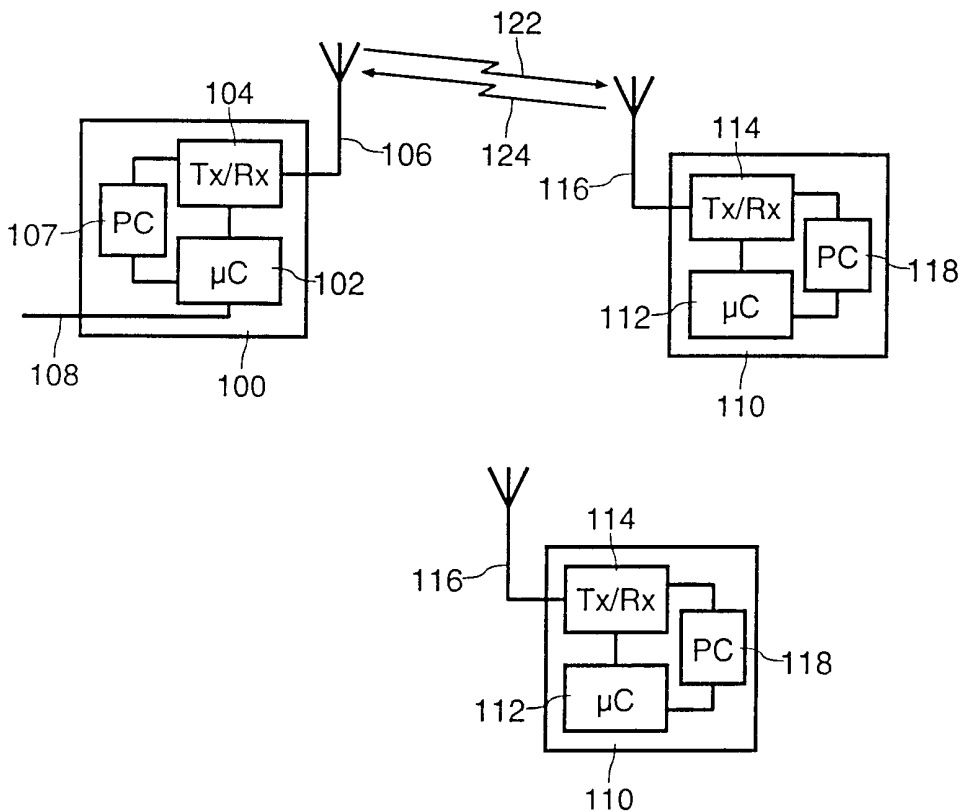

FIG. 1

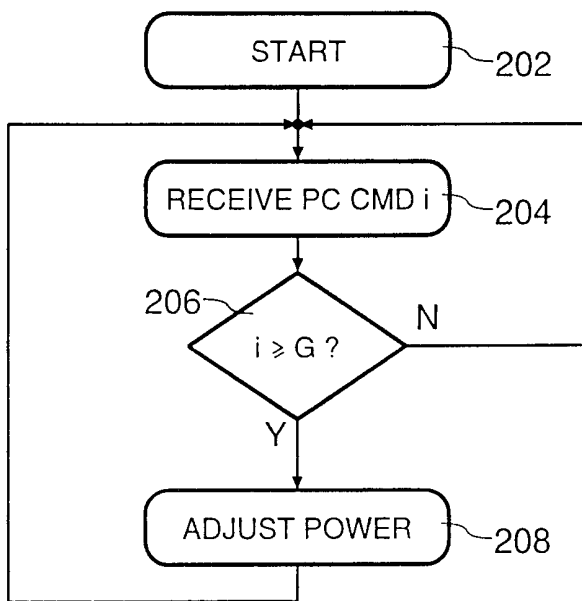

FIG. 2

2/2

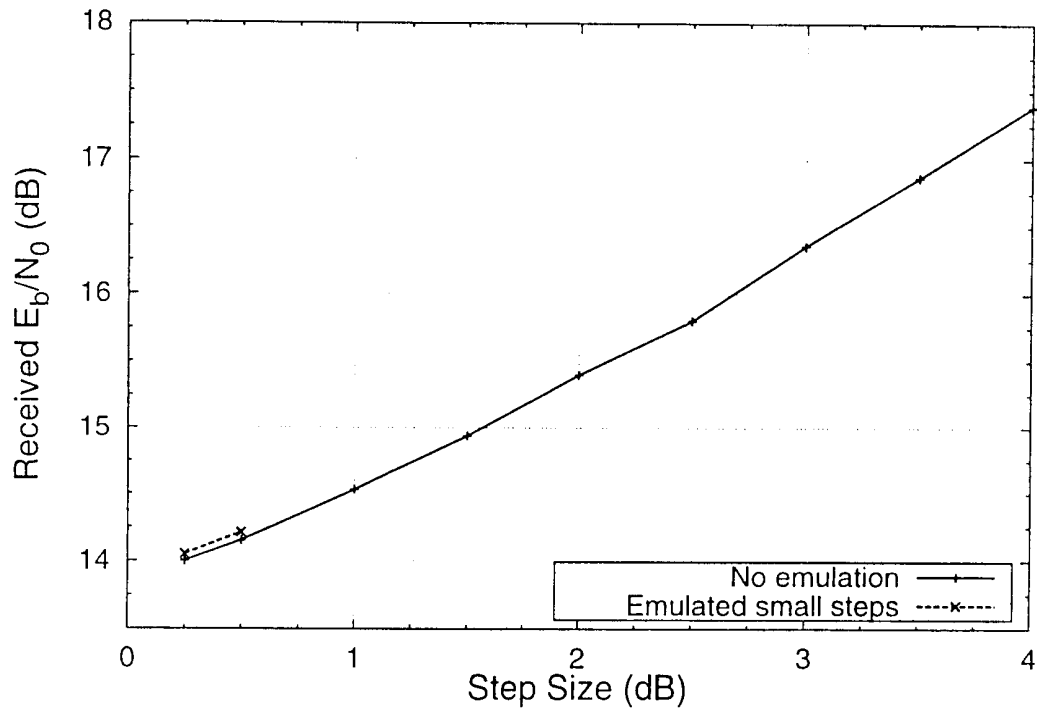

FIG. 3

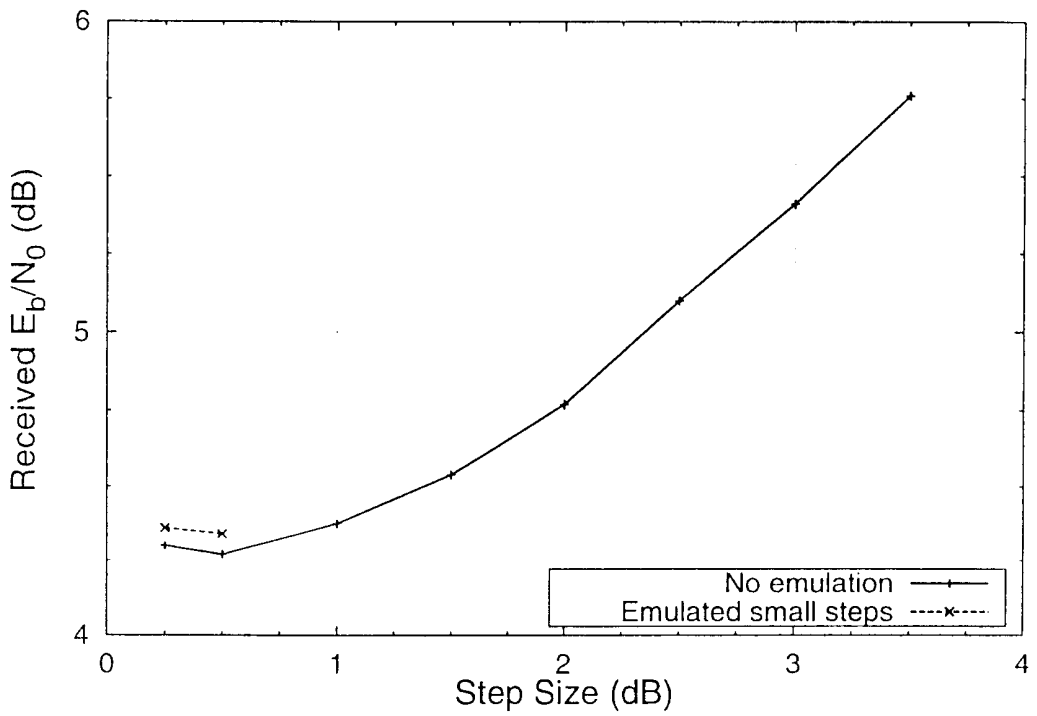

FIG. 4

INTERNATIONAL SEARCH REPORT

International Application No

PCT/EP 00/04217

A. CLASSIFICATION OF SUBJECT MATTER
IPC 7 H04B7/005

According to International Patent Classification (IPC) or to both national classification and IPC

B. FIELDS SEARCHED

Minimum documentation searched (classification system followed by classification symbols)

IPC 7 H04B

Documentation searched other than minimum documentation to the extent that such documents are included in the fields searched

Electronic data base consulted during the international search (name of data base and, where practical, search terms used)

EPO-Internal, INSPEC, PAJ

C. DOCUMENTS CONSIDERED TO BE RELEVANT

Category °	Citation of document, with indication, where appropriate, of the relevant passages	Relevant to claim No.
X	WO 97 26716 A (NOKIA MOBILE PHONES LTD ;NOKIA TELECOMMUNICATIONS OY (FI); SAARIO) 24 July 1997 (1997-07-24)	1-3,7-10
A	abstract page 3, line 31 -page 5, line 3 page 5, line 20 -page 9, line 3 claims 1-8	4-6
A	--- US 5 818 820 A (ANDERSON GARY B ET AL) 6 October 1998 (1998-10-06) column 8, line 65 -column 11, line 28 column 1, line 50 -column 2, line 54 --- -/--	1-3,9

Further documents are listed in the continuation of box C.

Patent family members are listed in annex.

° Special categories of cited documents :

- *A* document defining the general state of the art which is not considered to be of particular relevance
- *E* earlier document but published on or after the international filing date
- *L* document which may throw doubts on priority claim(s) or which is cited to establish the publication date of another citation or other special reason (as specified)
- *O* document referring to an oral disclosure, use, exhibition or other means
- *P* document published prior to the international filing date but later than the priority date claimed

- *T* later document published after the international filing date or priority date and not in conflict with the application but cited to understand the principle or theory underlying the invention
- *X* document of particular relevance; the claimed invention cannot be considered novel or cannot be considered to involve an inventive step when the document is taken alone
- *Y* document of particular relevance; the claimed invention cannot be considered to involve an inventive step when the document is combined with one or more other such documents, such combination being obvious to a person skilled in the art.
- *Z* document member of the same patent family

Date of the actual completion of the international search

8 August 2000

Date of mailing of the international search report

22/08/2000

Name and mailing address of the ISA

European Patent Office, P.B. 5818 Patentlaan 2
NL - 2280 HV Rijswijk
Tel. (+31-70) 340-2040, Tx. 31 651 epo nl,
Fax: (+31-70) 340-3016

Authorized officer

Gkeli, M

INTERNATIONAL SEARCH REPORT

International Application No
PCT/EP 00/04217

C.(Continuation) DOCUMENTS CONSIDERED TO BE RELEVANT		
Category °	Citation of document, with indication, where appropriate, of the relevant passages	Relevant to claim No.
A	<p>PATENT ABSTRACTS OF JAPAN vol. 1998, no. 10, 31 August 1998 (1998-08-31) & JP 10 126337 A (MITSUBISHI ELECTRIC CORP), 15 May 1998 (1998-05-15) abstract</p> <p>-----</p>	1-3,9

INTERNATIONAL SEARCH REPORT

Information on patent family members

International Application No

PCT/EP 00/04217

Patent document cited in search report	Publication date	Patent family member(s)	Publication date
WO 9726716 A	24-07-1997	FI 960276 A AU 716337 B AU 1446197 A EP 0815656 A JP 11506891 T NO 974312 A	20-07-1997 24-02-2000 11-08-1997 07-01-1998 15-06-1999 18-11-1997
US 5818820 A	06-10-1998	US 6088590 A CA 2186031 A EP 0763300 A IL 113059 A JP 9510844 T WO 9526094 A US 5671219 A US 5648955 A US 5768264 A US 6021333 A US 6005856 A US 5787076 A	11-07-2000 28-09-1995 19-03-1997 26-01-1999 28-10-1997 28-09-1995 23-09-1997 15-07-1997 16-06-1998 01-02-2000 21-12-1999 28-07-1998
JP 10126337 A	15-05-1998	US 5924043 A	13-07-1999