

(19) World Intellectual Property Organization
International Bureau



(43) International Publication Date
3 July 2008 (03.07.2008)

PCT

(10) International Publication Number
WO 2008/079258 A1

- (51) International Patent Classification:
H01Q 11/12 (2006.01)
- (21) International Application Number:
PCT/US2007/025994
- (22) International Filing Date:
19 December 2007 (19.12.2007)
- (25) Filing Language: English
- (26) Publication Language: English
- (30) Priority Data:
11/641,041 19 December 2006 (19.12.2006) US
- (71) Applicant (for all designated States except US): **BAE SYSTEMS INFORMATION AND ELECTRONIC SYSTEMS** [US/US]; Integration Inc., P.O.Box 868, NHQ01-719, Nashua, NH 03061-0868 (US).
- (72) Inventor; and
- (75) Inventor/Applicant (for US only): **APOSTOLOS, John, T.** [US/US]; 232 New Road, Lyndeborough, NH 03082 (US).

- (74) Agent: **LONG, Daniel, J.**; Bae Systems Information And Electronic Systems, Integration Inc., P.O.Box 868, NHQ01-719, Nashua, NH 03061-0868 (US).
- (81) Designated States (unless otherwise indicated, for every kind of national protection available): AE, AG, AL, AM, AT, AU, AZ, BA, BB, BG, BH, BR, BW, BY, BZ, CA, CH, CN, CO, CR, CU, CZ, DE, DK, DM, DO, DZ, EC, EE, EG, ES, FI, GB, GD, GE, GH, GM, GT, HN, HR, HU, ID, IL, IN, IS, JP, KE, KG, KM, KN, KP, KR, KZ, LA, LC, LK, LR, LS, LT, LU, LY, MA, MD, ME, MG, MK, MN, MW, MX, MY, MZ, NA, NG, NI, NO, NZ, OM, PG, PH, PL, PT, RO, RS, RU, SC, SD, SE, SG, SK, SL, SM, SV, SY, TJ, TM, TN, TR, TT, TZ, UA, UG, US, UZ, VC, VN, ZA, ZM, ZW.
- (84) Designated States (unless otherwise indicated, for every kind of regional protection available): ARIPO (BW, GH, GM, KE, LS, MW, MZ, NA, SD, SL, SZ, TZ, UG, ZM, ZW), Eurasian (AM, AZ, BY, KG, KZ, MD, RU, TJ, TM), European (AT, BE, BG, CH, CY, CZ, DE, DK, EE, ES, FI, FR, GB, GR, HU, IE, IS, IT, LT, LU, LV, MC, MT, NL, PL,

[Continued on next page]

(54) Title: VEHICULAR MULTIBAND ANTENNA

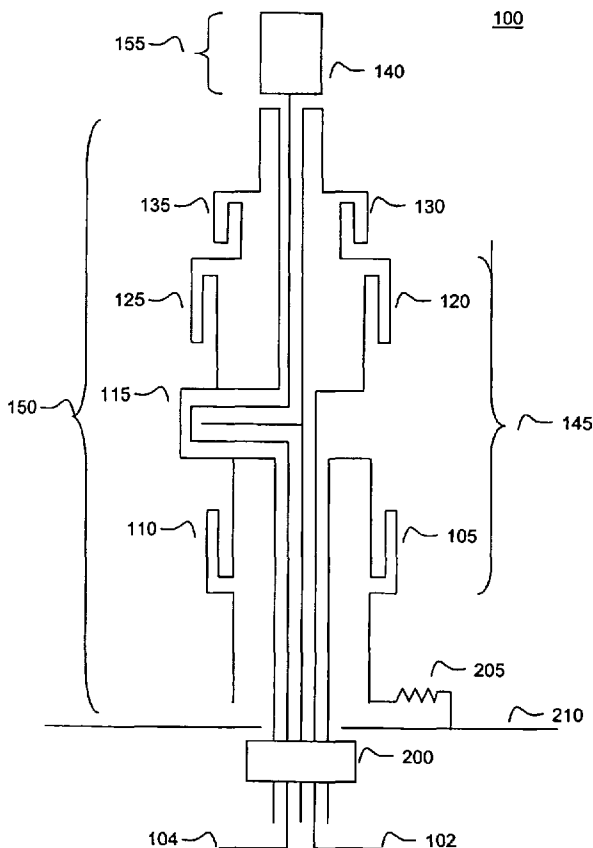

(57) Abstract: A coaxial antenna is implemented that combines a VHF and UHF antenna on a common radiating element. The antenna may further include a satellite antenna that, together with the VHF/UHF antenna fits into a whip antenna footprint.

WO 2008/079258 A1



PT, RO, SE, SI, SK, TR), OAPI (BF, BJ, CF, CG, CI, CM,
GA, GN, GQ, GW, ML, MR, NE, SN, TD, TG).

— *before the expiration of the time limit for amending the
claims and to be republished in the event of receipt of
amendments*

Published:

— *with international search report*

VEHICULAR MULTIBAND ANTENNA

CROSS REFERENCE TO RELATED APPLICATIONS:

This patent application is related to a co-pending patent application filed on the same day as the present application, having the title "Vehicular Multiband Antenna" and the applicant John T. Apostolos.

FIELD OF THE INVENTION:

The present invention relates generally to antennas and, more particularly, to a compact antenna that is capable of transmitting and receiving signals in multiple bands and of being mounted on a vehicle to facilitate communications.

BACKGROUND OF THE INVENTION:

Communication antennas, including communications antennas for vehicles, are generally adapted to receive and/or transmit and receive signals in a particular frequency range. The antennas are sized and configured in order to optimize efficiency at particular frequency ranges.

VHF, UHF and satellite antennas have conventionally been implemented in separate antenna structures. For example, receiving satellite antennas have generally been implemented with a dish type antenna structure while VHF and UHF antennas have generally been implemented as monopole or dipole antennas and sometimes as dipole array structures. UHF antennas have also been implemented as dish antennas. To miniaturize the size of antennas, meander line loaded antennas are known and are exemplified by U.S. Patent Nos. 5,790,080; 6,323,814; 6,373,440; 6,373,446; 6,480,158; 6,492,953; 6,404,391 and 6,590,593, assigned to the assignee hereof and incorporated herein by reference. However, notwithstanding various

antenna design techniques, conventional, VHF and UHF and satellite antennas have generally not been combined into a single antenna structure.

For example, military, law enforcement and even commercial vehicles may be required to be equipped with communications devices to permit operators to exchange information with a variety of different information services, command and control or dispatch centers, GPS and other information. Therefore, it is not uncommon for such vehicles to include multiple, separate antennas, each designed to communicate efficiently at a particular frequency range or a few frequency ranges.

There is a need, however, for an antenna that is capable of transmitting in the VHF, UHF and satellite frequency ranges using a shared radiating element. There is a further need for a combined antenna to assume a standard footprint, such as a co-axial whip antenna, that may be implemented and fitted onto existing vehicles. There is still a further need for a combined antenna capable of efficient operation in the following four frequency bands: 30 – 88 MHz, 108 – 156 MHz, 225 – 450 MHz and 1350 – 1550 and 1650 – 1850 MHz that fits into the form factor of a 30 - 88 MHz whip antenna.

SUMMARY OF THE INVENTION:

According to the present invention, a coaxial antenna is implemented that combines a VHF and UHF antenna on a common radiating element. The antenna may further include a satellite antenna that, together with the VHF/UHF antenna fits into a whip antenna footprint.

According to one embodiment of the invention, a coaxial antenna capable of operating in at least two different frequency ranges includes radiating elements and chokes. The radiating elements are capable of operating in a first frequency range of interest and the chokes limit the

operating efficiency of at least portions of the radiating elements at the second frequency range. The choked portions of the radiating elements are not excited efficiently at the second frequency range of interest and therefore create two different effective antenna configurations for the different frequency ranges handled by the antenna. The first frequency range may be lower than or greater than the second frequency range. Embodiments of antennas according to the present invention may include transmitting antennas, receiving antennas or antennas that transmit and receive signals.

According to additional embodiments of the present invention, communication with the antenna at the first and second frequency ranges may occur through a common conductor and the common conductor may form at least part of the radiating elements capable of operating at the first and second frequency ranges. In addition the common conductor may be a shielded conductor, such as a coaxial cable. The first and second frequency ranges may comprise frequency ranges in the UHF and VHF frequency bands, respectively.

According to still other embodiments of the invention, the antenna may further include a second conductor capable of carrying a third frequency range. In this configuration, the common conductor and second conductor may enter the base of the antenna and the second conductor may be coupled to an antenna element, which may be a satellite antenna, at the top end of the antenna for operation in the third (and even additional) frequency ranges. The third frequency range may include a L band frequency range or other frequency ranges, including those used for satellite communication.

According to one embodiment of the invention, an antenna according to the present invention is configured to have similar overall dimensions as the Army's AS3900A whip antenna and operate at 30 – 88 MHz and 108 – 156 MHz in the first frequency range; 225 – 450

MHz in the second frequency range; and 1350 – 1550 and 1650 – 1850 MHz in the third frequency range.

BRIEF DESCRIPTION OF THE FIGURES:

The above described features and advantages of the present invention will be more fully appreciated with reference to the accompanying detailed description and figures, in which:

Figure 1 depicts a coaxial antenna for multi band operation according to an embodiment of the present invention.

Figure 2 depicts an illustrative voltage standing wave ratio (VSWR) pattern for a half size model of an antenna as shown in Figure 1.

Figure 3 depicts an illustrative graph the peak measured gain from 0 to 15 degrees of elevation angle in the VHF band.

Figure 4 depicts an illustrative graph of the peak measured gain from 0 to 70 degrees of elevation angle in the UHF band.

Figures 5a - 5d depict illustrative elevation patterns over the VHF / UHF bands at frequencies of 30 MHz, 160 MHz, 300 MHz and 450 MHz respectively. These graphs generally depict good elevation coverage from 0 to 180 degrees, with notches in the gain around 90 degrees.

Figure 6 depicts a coaxial antenna for multi band operation according to another embodiment of the present invention.

Figure 7 depicts a coaxial antenna for multi band operation according to another embodiment of the present invention.

Figure 8 depicts an illustrative matching network that may be implemented at the antenna base to couple the UHF sleeve to, for example, a ground plane.

Figure 9 depicts an illustrative matching network that may be implemented at the VHF/UHF signal input.

DETAILED DESCRIPTION:

According to the present invention, a coaxial antenna is implemented that combines a VHF and UHF antenna on a common radiating element. The antenna may further include a satellite antenna that, together with the VHF/UHF antenna fits into a whip antenna footprint. The antenna uses a common feed for the UHF/VHF antenna and a separate feed for the satellite antenna.

Figure 1 depicts an electrical cross section of electrical elements within an antenna 100 according to an embodiment of the present invention. Referring to Figure 1, the antenna 100 is a co-axial antenna that that may be suited to a variety of uses, including mounting on a vehicle or a structure. The antenna 100 may be elongated and fit within a whip antenna footprint. In addition, according to one embodiment of the invention, the antenna 100 may be a whip antenna of approximately 96 inches in length and be footprint compatible with the vehicular antenna designated ASS3900A by the U.S. Army. In such a configuration, the antenna may operate in four bands, and specifically 30-88 MHz, 108-156 MHz, 225-450 MHz and 1350-1550, 1650-1850 MHz. It will be understood that this preferred configuration is only one implementation of a multi-band antenna according to the present invention, and that other frequencies of operation

and footprints may be implemented according to the description and considerations provided herein.

Referring to Figure 1, the antenna 100 has three sections and a feed at its base: a satellite antenna section 155, a VHF section 150 and a UHF section 145. The antenna is fed at its base by a UHF/VHF feed 102 and a satellite feed 104. The satellite section 155 includes a satellite antenna 140. The satellite antenna 140 is generally positioned at the top of the antenna structure to facilitate extra terrestrial communication. The satellite antenna may be any convenient type or size satellite antenna depending on the application, frequencies of interest, footprint and other antenna requirements. The satellite may include, for example, a dish antenna, a quadrifiler helix antenna or asymmetric dipole antenna, among others. According to one embodiment of the invention, the satellite antenna is a L band satellite antenna that operates in the frequency ranges 1350-1550 and 1650-1850 MHz.

The satellite antenna 140 is fed through the antenna structure by the L band satellite feed 104. The feed 104 traverses the length of the antenna structure 100 from its base to the satellite antenna 104. According to one embodiment of the invention, the feed comprises a transmission line, such as a coaxial cable or other shielded conductor, that passes through the UHF/VHF feed 102 by rotation around a ferrite loaded coil. This coil may be used to resonate the VHF portion of the antenna at low end frequencies. The shields of the L-band and VHF/UHF conductors may be coupled together along their length and are electrically coupled to the lower portions of the UHF/VHF antenna structure portions 145 and 150.

The lower VHF/UHF antenna portions 145 and 150, according to one embodiment of the invention, are coupled at one end to the shields and may be coupled at the other end to a ground plane, through a resistive element, for example through a 50 ohm shunt resistor. However, it will

be understood that other values may be used. In general, the shunt resistor, together with other elements of the antenna structure, provides a distributed loss function at lower frequencies.

The upper portions of the VHF/UHF antenna structure and the 145 and 150 are coupled to the central conductor of the VHF/UHF feed. This central conductor carries a multiplexed VHF/UHF signal that is received via the antenna or that is fed to the antenna for transmission over the VHF/UHF feed. In this configuration, the VHF antenna comprises a centrally fed coaxial antenna that has an electrical length represented by the length of the portion 150. At the same time, the UHF portion of the combined antenna structure is implemented along a portion of the length of the VHF antenna, namely the portions identified as 145. The VHF antenna structure includes along its electrical length chokes 105, 110; 120, 125 and 130, 135. The chokes may be implemented in any convenient manner. According to one embodiment of the invention, the chokes may be implemented as cylindrical versions of strip meanderline transmission lines with high and low impedance sections. In this embodiment, the coaxial chokes are cylinders of revolution of the meanderline structure seen in the cross section of Figure 1. Other examples of chokes include strip meanderlines and coaxial meanderlines. The chokes are used to allow lower frequency VHF signals to propagate along the full length of the antenna structure between the base and the chokes 130, 135 while the UHF signals are confined to the portion between 105 and 120. The chokes are pictured as appearing on the left and right side of the antenna structure. However, it will be understood that due to the coaxial nature of the antenna, chokes 105 and 110 (and the other choke pairs as shown) may be implemented as a single choke in this configuration.

Figure 2 depicts an illustrative voltage standing wave ratio (VSWR) pattern for a half size model of an antenna as shown in Figure 1. The illustrative graph depicts VSWR taken at frequencies from 60 to 900 MHz. The frequency axes were scaled by 1/2 to show what the

performance would be in the 30 to 450 MHz range. The half size model has a total length of 48 inches (diameter 0.625) and the UHF/VHF section is 42 inches (diameter 0.625). The full size model has a total length of 96 inches (diameter 1.25) and the UHF/VHF section is 84 inches (diameter 1.25). The VSWR of the antenna shows a variation in the VSWR of between 2.5 to about 1.5 between 30 MHz and 450 MHz.

A ferrite element 165 may be implemented at the base of the antenna so that the VHF/UHF conductors and the L-band conductors are wound around the base. The base (not shown) is generally used for mounting and to facilitate making electrical connection to the ground plane and to the VHF/UHF and L-band feeds.

According to one embodiment of the invention, the full length of the multi band antenna is utilized for frequencies less than 160 MHz. Losses in the chokes, together with losses in the ferrite elements shown and the resistive element results in diminished efficiency at low frequencies. The efficiency of the VHF antenna at 30 MHz is about 25 % and the total length of the multi-band antenna, from the base to the L band antenna is approximately 96 inches.

Figures 3 - 5 depict illustrative graphs of the antenna configured over a 10 foot by 10 foot ground plane. All of the frequencies in the graphs are scaled by 1/2. The data was actually taken from 60 to 320 MHz for VHF and 460 to 900 MHz for UHF. Figure 3 depicts an illustrative graph the peak measured gain from 0 to 15 degrees of elevation angle in the VHF band. Referring to Figure 3, the peak antenna gain over the range from 0 to 15 degrees ranges from -6 dbmp to -2 dbmp at 150 Mhz. The gain drops to about -4 dbmp at 160 MHz.

Figure 4 depicts an illustrative graph of the peak measured gain from 0 to 60 degrees of elevation angle in the UHF band. Because of the size of the ground plane and the height of the active UHF portion of the antenna, there are lobes in the elevation pattern with 3 - 6 db of extra

gain over that in free space. Referring to Figure 4, the peak gain appears around 410 MHz and the low at 310 MHz.

Figures 5a - 5d depict illustrative elevation patterns over the VHF / UHF bands at frequencies of 30 MHz, 160 MHz, 300 MHz and 450 MHz respectively. These graphs generally depict good elevation coverage from 0 to 180 degrees, with notches in the gain around 90 degrees.

During operation, the multi-band antenna may be positioned on a ground plane, for example on a surface of a vehicle. The feeds of the L-band and VHF/UHF band antenna are then coupled to a transceiver to transmit and receive signals via the multi-band antenna in frequencies of interest. The VHF/UHF signals for transmission via the multi-band antenna are multiplexed onto the VHF/UHF feed for transmission. The L band satellite signal is transmitted onto the L-band feed. The VHF signals on the VHF/UHF feed are radiated by the antenna along the electrical length of the antenna between the base and the chokes 130, 135. The UHF signals on the VHF/UHF feed are radiated by the antenna along the electrical length of the antenna between the chokes 105, 110 and 120, 125. The L-band signals traverse the length of the antenna structure and reach the L-band antenna where they are transmitted by the L-band antenna.

When receiving signals, the electrical length of the antenna between the base and the chokes 130, 135 receive signals and which are electrically coupled to the VHF/UHF feed that transverse the feed to the receiver which de-multiplexes the VHF signal from the UHF signal. UHF signals are received along the electrical length of the antenna between the chokes 105, 110 and 120, 125, are electrically coupled to the VHF/UHF feed and are demultiplexed from the VHF signals by a receiver. Similarly, L band signals are received by the L band antenna and coupled to the receiver via the L band feed.

Figure 6 depicts a multi-band feed antenna 600 according to another embodiment of the present invention. This embodiment is similar to the embodiment depicted in Figure 1. Referring to Figure 6, the antenna is a coaxial antenna that includes VHF and UHF portions 640 and 645 and a L band antenna 660. The antenna includes shielded conductors 605 and 610 that respectively are coupled to the antenna 600 at its base to allow the communication of signals between the antenna and transceiver equipment. The shielded conductors 605 and 610 may be any type of shielded conductor, including coaxial cable. The shielded conductors 605 and 610 may be wrapped around a ferrite loaded coil according to one embodiment of the invention as discussed above with reference to Figure 1. The shields 630 of the conductors 605 and 610 may be electrically coupled together as shown. In addition, the central conductor of the VHF/UHF shielded conductor may be coupled as shown to the lower VHF/UHF portion of the antenna structure as shown, while the shields 630 may be coupled to the upper VHF/UHF portion of the antenna structure as shown. In this configuration, the VHF/UHF antenna feed is located in the approximate middle of the VHF/UHF antenna portions between the portion fed by the central conductors and the other portion fed by the conductor shields. The L band central conductor passes through the shields and is coupled at upper end of the antenna to a L band antenna 660. According to this embodiment, the ground plane is coupled to the shields at the base. The coaxial chokes may be coaxial meanderline chokes as described above or any other choke element for confining frequencies of interest between the chokes lower chokes in one frequency band and between the base and the upper chokes in another frequency band, for example the UHF and VHF frequency bands according to a preferred embodiment of the invention. It will be understood, however, that the chokes for any embodiments may be adjusted to change the frequencies of interest for which the different portions of the antenna are effectively active.

Figure 7 depicts a multi-band antenna 700 according to another embodiment of the present invention. Referring to Figure 7, the antenna 700 is a coaxial antenna with a base on the left side of the figure and an upper end at the right side of the figure. At the base of the antenna, signals are provided to and from the antenna 700 via a VHF/UHF shielded conductor 705 and via a L band shielded conductor 710. The antenna 700 of Figure 7 may have the same overall dimensions as an antenna according to Figures 1 or 6 and may operate in any number of frequency ranges, including the VHF, UHF and L band frequency ranges described above.

Similar to the antennas of Figures 6, the shields of the L band and VHF/UHF conductors are coupled together. The shields may be further coupled to the VHF stub 715, which is coaxial and capacitively coupled to ground. The VHF/UHF central conductor is coupled to the VHF/UHF antenna 722, which is in turn coupled to the VHF stub 715 through a choke 735, which may be a meanderline choke or any other type choke as described above that provides the appropriate division between two frequency ranges, in a preferred case the VHF/UHF frequencies described above. In addition, a UHF sleeve 730 may be coupled to the base of the VHF stub. The UHF sleeve may be further coupled to the ground plane 712 through a matching network 714 that may have the same or approximately the same parameters as a matching network implemented as an input to the VHF/UHF conductors 705. In this configuration, the VHF/UHF feed 720 is approximately at the center of the antenna 700 as shown between the lower and upper portions of the antenna.

The upper portion of the antenna may include a break region 725. The break region is a region of the antenna that may be separated, and generally includes blind mate connectors and mating threading to allow upper and lower antenna portions to be screwed together to create both mechanical and electrical connections to permit, for example, the L band signals to pass through

the break region. The shields from the conductors 705 and 710 are coupled to the upper VHF/UHF antenna portion 732, which are further coupled to an upper VHF stub 734 through a choke 735. The choke 735 matches the choke implemented in the lower portion of the antenna. In one embodiment, the meanderline chokes may include a cut off frequency at 225 MHz. This acts as a low pass filter. In addition, the outer conductor of the L band conductor may be shorted to the upper VHF stub 734 as shown. In addition, the at the upper end of the antenna 700, the L band conductor (and shields) passes the upper VHF stub and through L band sleeves. The shields of the L band conductor then form part of a L band dipole at the upper end and the L band central conductor is coupled to an L band antenna 760 at the upper end of the antenna. Such a configuration may be implemented to realize a 96 inch coaxial antenna, in a preferred embodiment, that radiates in the frequency ranges identified above.

Figure 8 depicts an illustrative matching network that may be implemented at the antenna base to couple the UHF (or other frequency of interest) sleeve to, for example, a ground plane. Such a network may include, for example, a 250 ohm resistive element 810 that is series coupled to a 12 pf capacitor element 820 and a 0.2 micro henry inductor element 830.

Figure 9 depicts an illustrative matching network that may be implemented at the VHF/UHF signal input (or input for signals at other frequencies of interest) to facilitate coupling to a VHF/UHF conductor within the antenna. Referring to Figure 9, the network includes a 20pf capacitor element 920 through which the VHF/UHF signals are carried. In addition, a 10pf capacitor element 910 and a 1 micro henry inductor element 930 may be coupled in parallel to ground.

While particular embodiments of the invention have been shown and described, it will be understood that changes may be made to those embodiments without departing from the spirit

and scope of the invention. For example, while particular frequency ranges and VHF, UHF and L band frequencies have been described, it will be understood that frequencies outside of these frequency ranges may be implemented according to the present invention.

CLAIMS:

What is claimed is

1. A coaxial antenna capable of operating in at least two different frequency ranges, comprising:
 - radiating elements capable of operating in a first frequency range of interest;
 - chokes that limit the operating efficiency of at least portions of the radiating elements at the second frequency range; and
 - wherein the choked portions of the radiating elements are not capable of efficient operation at the second frequency range of interest.
2. The coaxial antenna according to claim 1, wherein the first frequency range is lower than the second frequency range.
3. The coaxial antenna according to claim 1, wherein the first frequency range is higher than the second frequency range.
4. The coaxial antenna according to claim 1, wherein the antenna is capable of use for at least one of transmitting and receiving at each of the frequency ranges.
5. The coaxial antenna according to claim 1, wherein the communication with the antenna at the first and second frequency ranges occurs through a common conductor.

6. The coaxial antenna according to claim 5, wherein the common conductor forms at least part of the radiating elements capable of operating at the first and second frequency ranges.
7. The coaxial antenna according to claim 5, wherein first and second frequency ranges comprise frequency ranges in the UHF and VHF frequency bands, respectively.
8. The coaxial antenna according to claim 5, wherein the common conductor is a shielded conductor.
9. The coaxial antenna according to claim 5, wherein the common conductor is a coaxial cable.
10. The coaxial antenna according to claim 5,
further comprising a second conductor capable of carrying a third frequency range; and
wherein the antenna includes a base end and a top end, the common conductor and second conductor enter the base and the second conductor is coupled to an antenna element at the top end of the antenna.
11. The coaxial antenna according to claim 10, wherein the third frequency range is associated with the L band frequency range.
12. The coaxial antenna according to claim 10, wherein the antenna element comprises a satellite antenna.

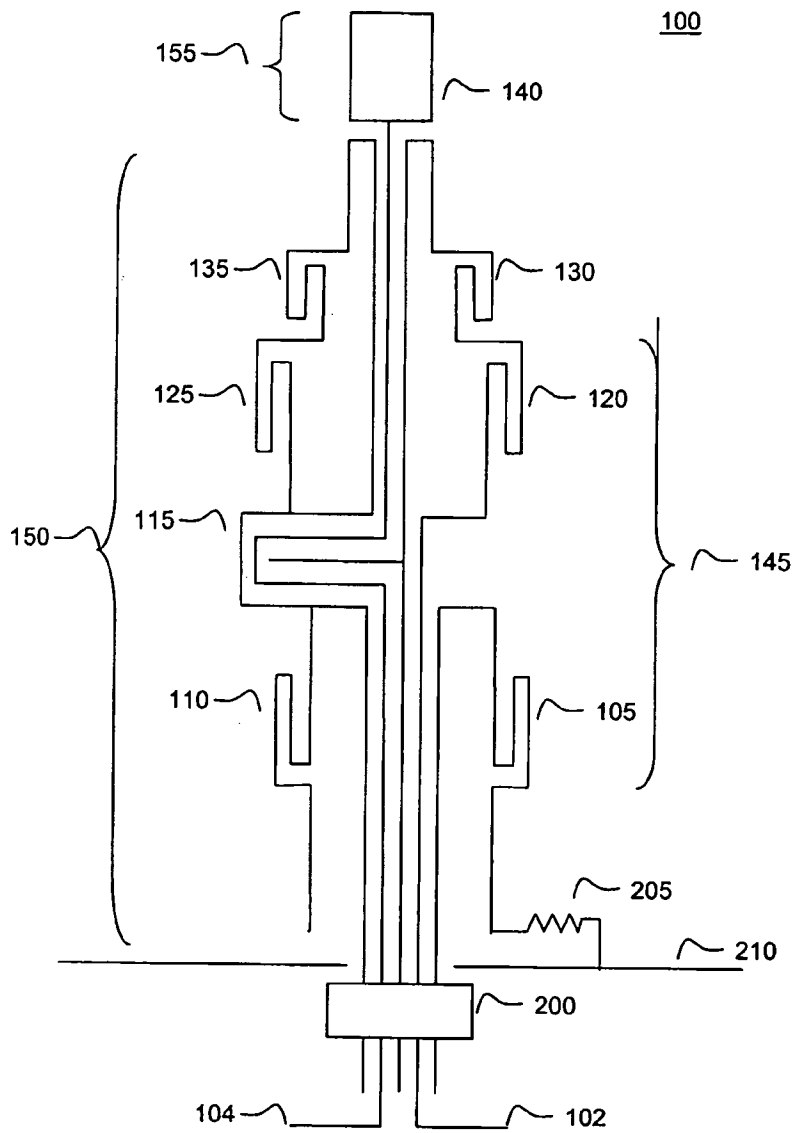

FIGURE 1

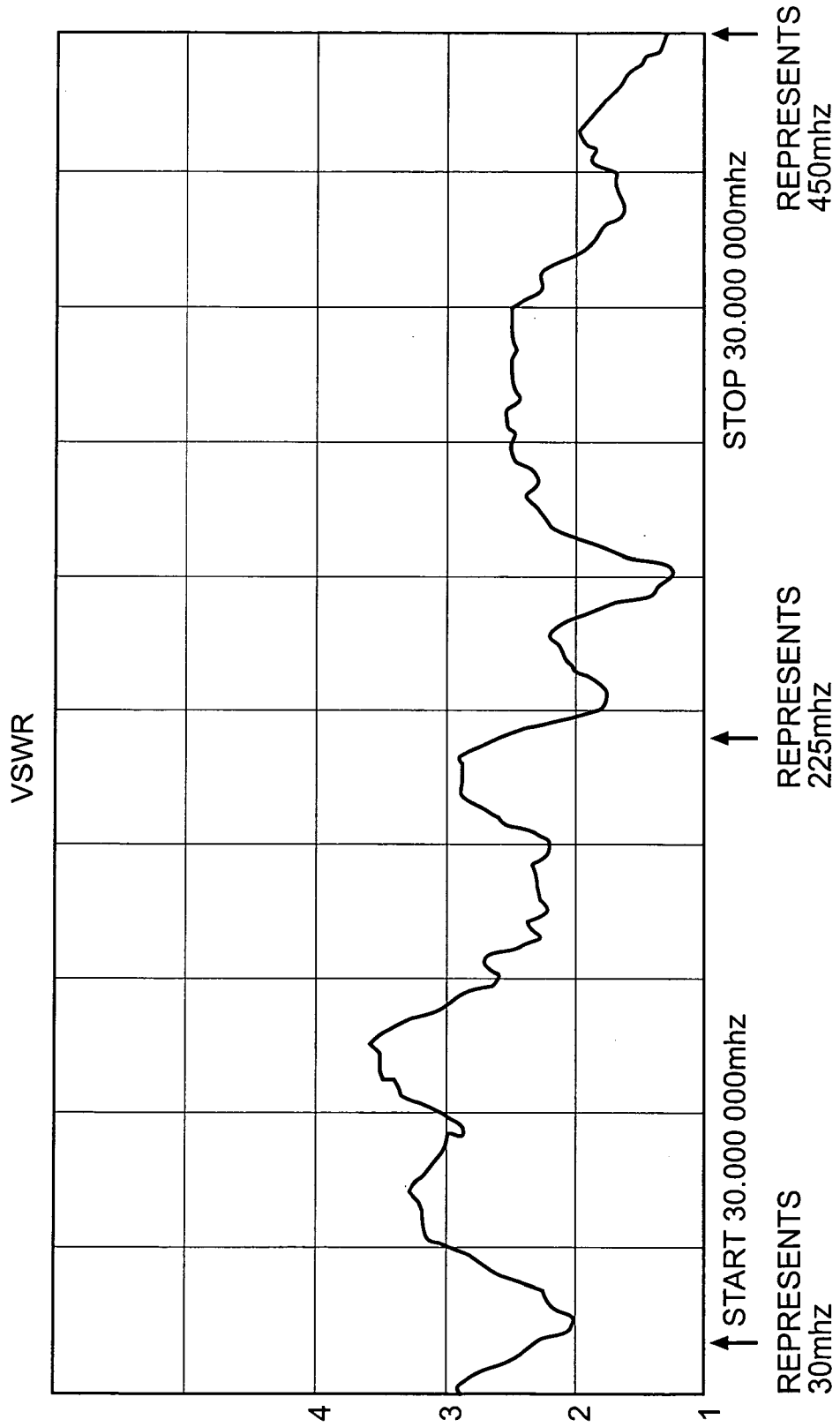

FIG. 2

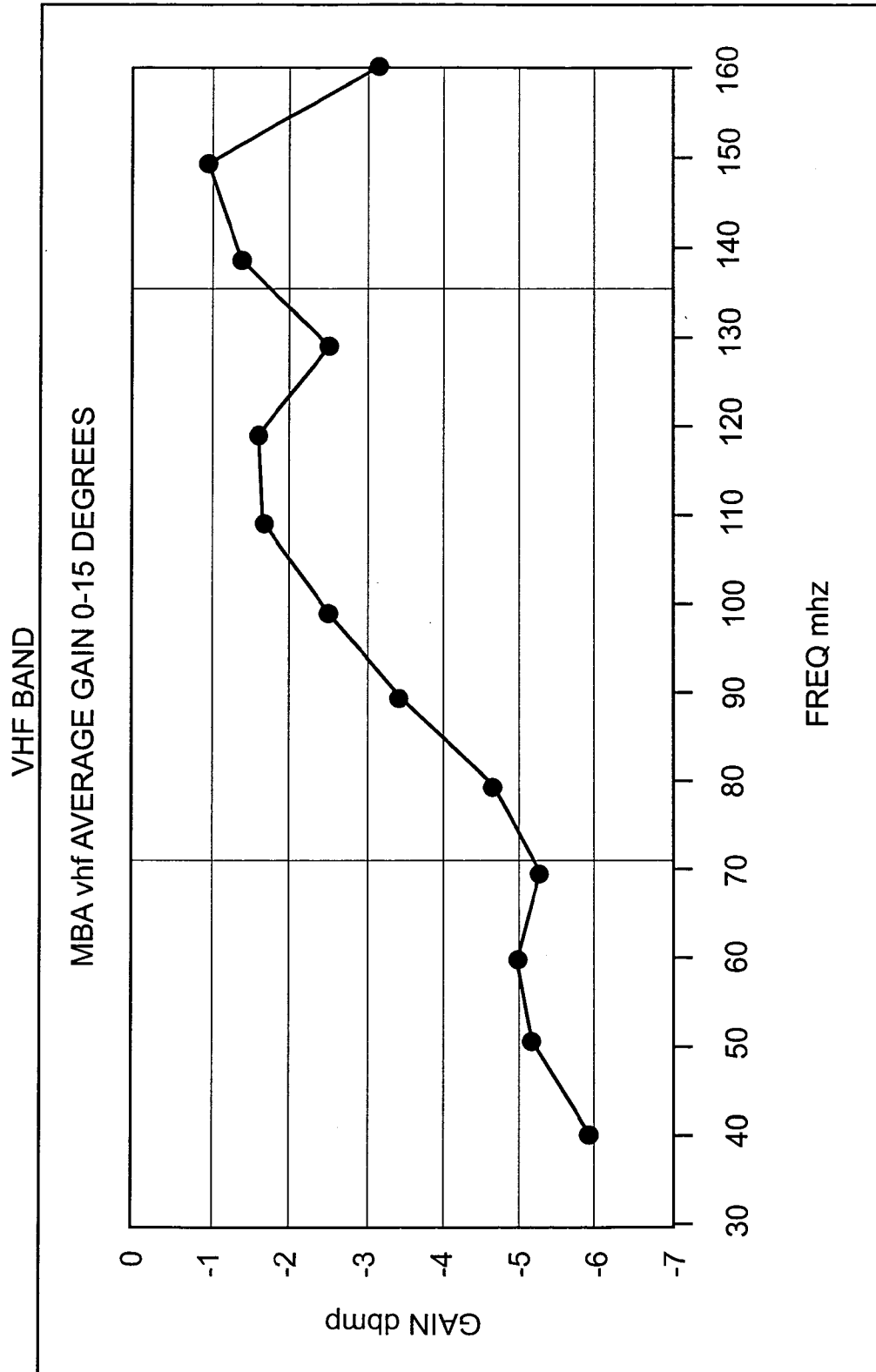

FIG. 3

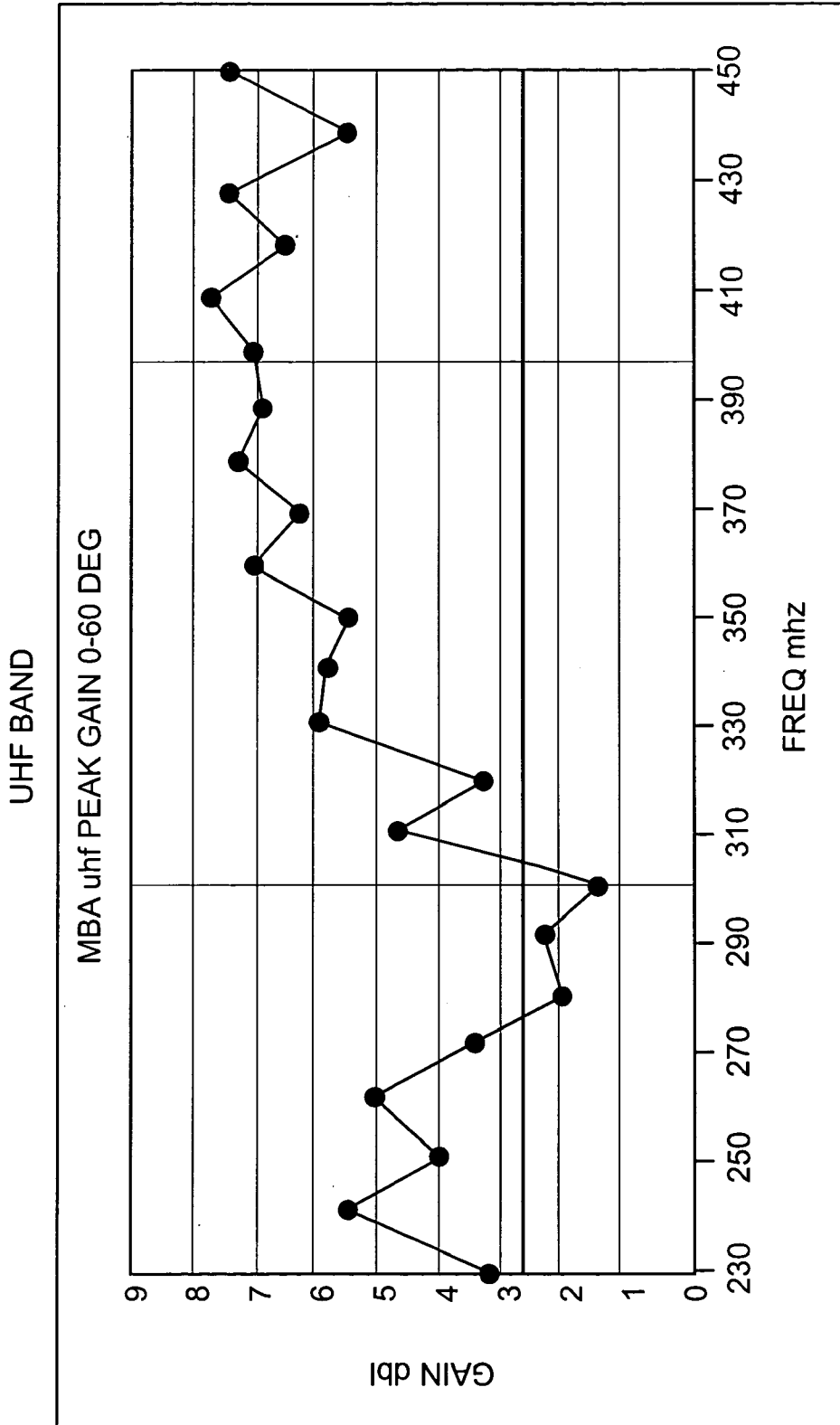

FIG. 4

FIGURE 5A

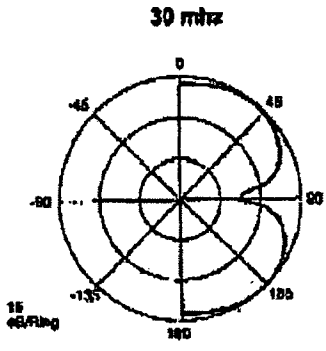
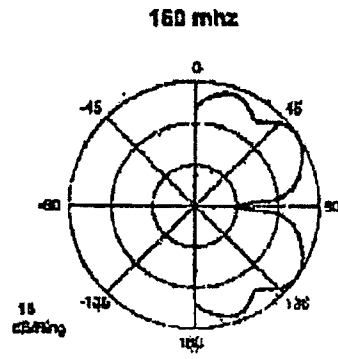

FIGURE 5B



300 mhz

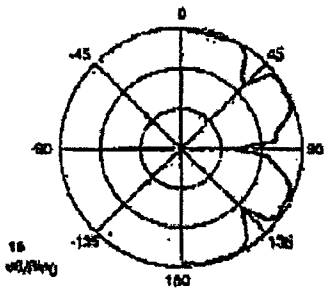

FIGURE 5C

450 MHz

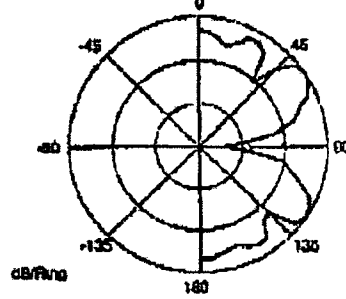

FIGURE 5D

FIGURE 6

600

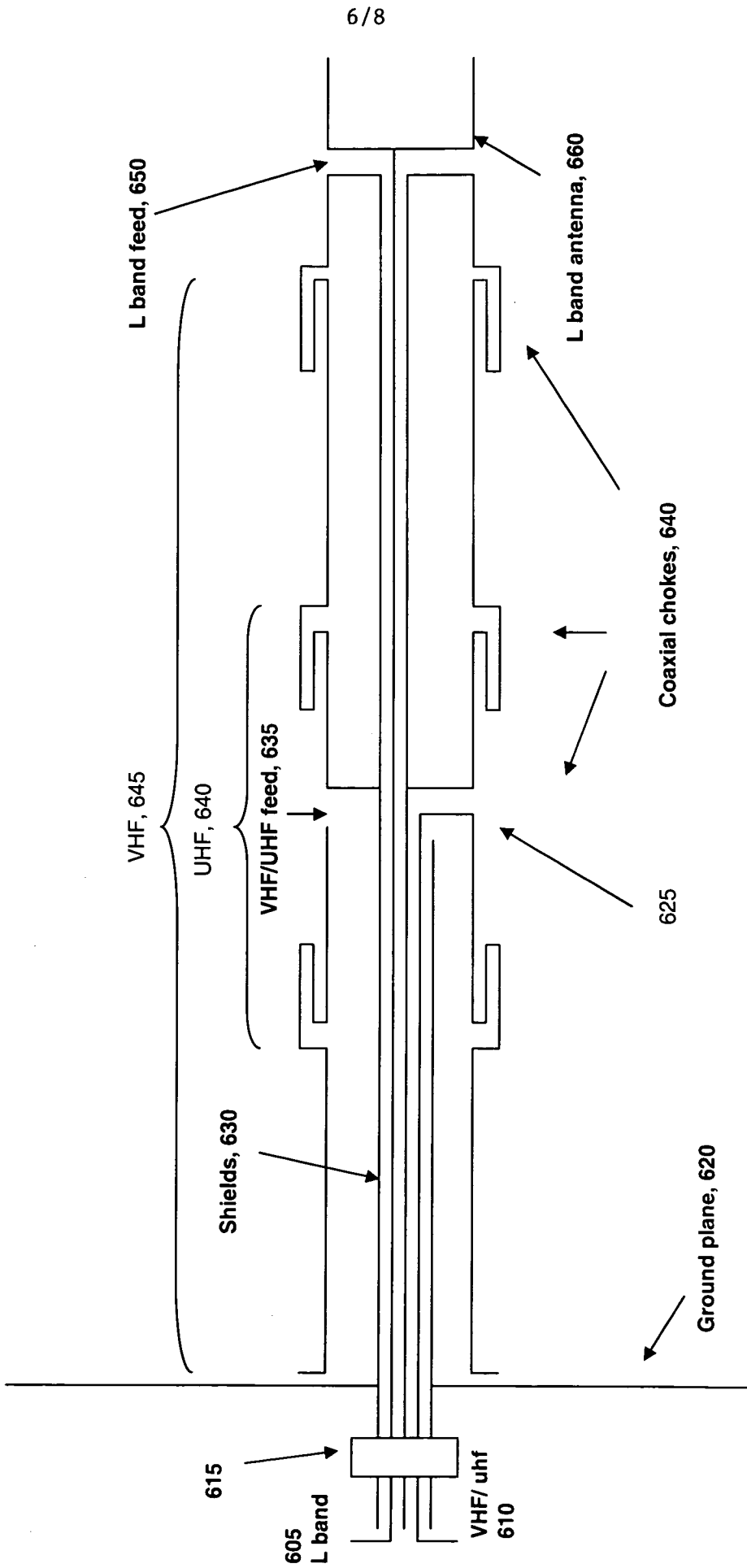
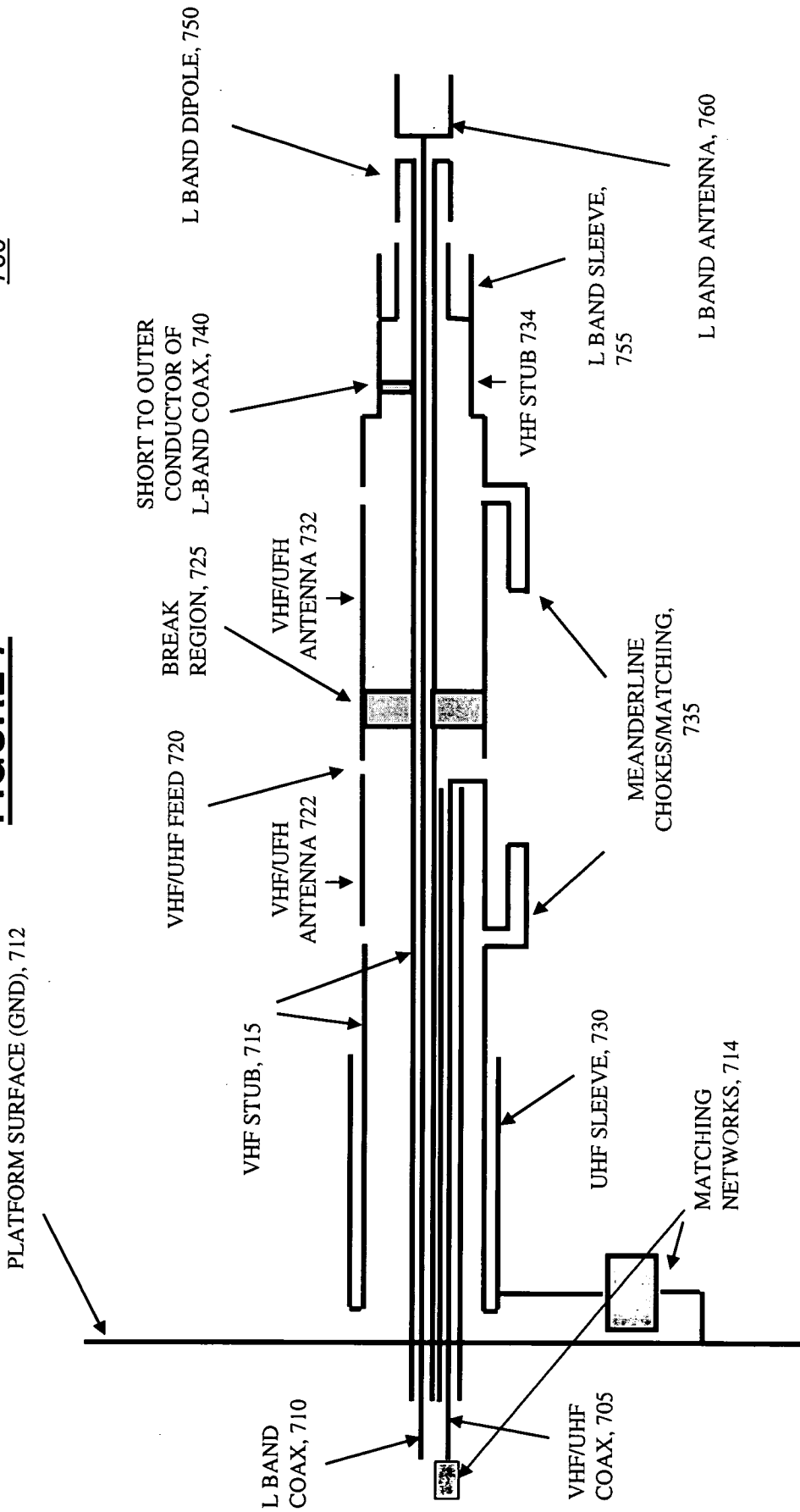

FIGURE 7

700



ANTENNA ELEMENT BASE

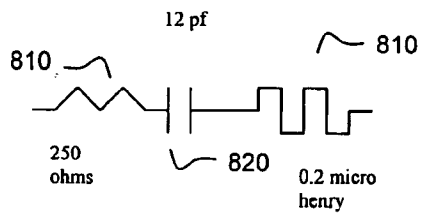

FIGURE 8

VHF/UHF INPUT(705)

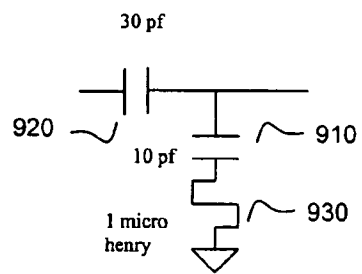

FIGURE 9

INTERNATIONAL SEARCH REPORT

International application No.

PCT/US07/25994

A. CLASSIFICATION OF SUBJECT MATTER

IPC(8) - H01Q 11/12 (2008.04)

USPC - 343/774

According to International Patent Classification (IPC) or to both national classification and IPC

B. FIELDS SEARCHED

Minimum documentation searched (classification system followed by classification symbols)

IPC(8) - H01Q 11/12 (2008.04)

USPC - 343/774

Documentation searched other than minimum documentation to the extent that such documents are included in the fields searched

Electronic data base consulted during the international search (name of data base and, where practicable, search terms used)

MicroPatent

C. DOCUMENTS CONSIDERED TO BE RELEVANT

Category*	Citation of document, with indication, where appropriate, of the relevant passages	Relevant to claim No.
X	US 6,967,626 B2 (APOSTOLOS) 22 November 2005 (22.11.2005) Entire Document.	1-10
Y		11-12
Y	US 6,606,069 B2 (KITAMURA et al) 12 August 2003 (12.08.2003) Entire Document.	11-12
A	US 2005/0225496 A1 (APOSTOLOS et al) 13 October 2005 (13.10.2005) Entire Document.	1-12

Further documents are listed in the continuation of Box C.

* Special categories of cited documents:

"A" document defining the general state of the art which is not considered to be of particular relevance

"E" earlier application or patent but published on or after the international filing date

"L" document which may throw doubts on priority claim(s) or which is cited to establish the publication date of another citation or other special reason (as specified)

"O" document referring to an oral disclosure, use, exhibition or other means

"P" document published prior to the international filing date but later than the priority date claimed

"T" later document published after the international filing date or priority date and not in conflict with the application but cited to understand the principle or theory underlying the invention

"X" document of particular relevance; the claimed invention cannot be considered novel or cannot be considered to involve an inventive step when the document is taken alone

"Y" document of particular relevance; the claimed invention cannot be considered to involve an inventive step when the document is combined with one or more other such documents, such combination being obvious to a person skilled in the art

"&" document member of the same patent family

Date of the actual completion of the international search

16 April 2008

Date of mailing of the international search report

02 MAY 2008

Name and mailing address of the ISA/US

Mail Stop PCT, Attn: ISA/US, Commissioner for Patents
P.O. Box 1450, Alexandria, Virginia 22313-1450

Facsimile No. 571-273-3201

Authorized officer:

Blaine R. Copenheaver

PCT Helpdesk: 571-272-4300
PCT OSP: 571-272-7774

