



(19) **United States**

(12) **Patent Application Publication**
Van Dam et al.

(10) **Pub. No.: US 2009/0143759 A1**

(43) **Pub. Date: Jun. 4, 2009**

(54) **METHODS, DEVICES, KITS AND SYSTEMS FOR DEFUNCTIONALIZING THE CYSTIC DUCT**

Publication Classification

(76) Inventors: **Jacques Van Dam**, San Carlos, CA (US); **J. Craig Milroy**, Palo Alto, CA (US); **R. Matthew Online**, Redwood City, CA (US)

(51) **Int. Cl.**
A61M 31/00 (2006.01)
A61M 25/10 (2006.01)
A61B 17/22 (2006.01)
A61B 18/02 (2006.01)
A61B 18/04 (2006.01)
A61B 18/18 (2006.01)
A61H 1/00 (2006.01)
A61B 17/03 (2006.01)

(52) **U.S. Cl.** **604/500**; 604/288.04; 604/96.01; 606/127; 606/21; 606/27; 606/41; 601/2; 606/213

Correspondence Address:
WILSON SONSINI GOODRICH & ROSATI
650 PAGE MILL ROAD
PALO ALTO, CA 94304-1050 (US)

(21) Appl. No.: **12/277,338**

(22) Filed: **Nov. 25, 2008**

(57) **ABSTRACT**

The application discloses devices, systems, kits and methods for treating biliary disease. Devices comprise, for example, a component configurable for deployment between within a cystic duct of a patient which has a proximal end and a distal end. In some embodiments, a lumen may also extend there-through.

Related U.S. Application Data

(60) Provisional application No. 60/991,682, filed on Nov. 30, 2007, provisional application No. 61/033,368, filed on Mar. 3, 2008.

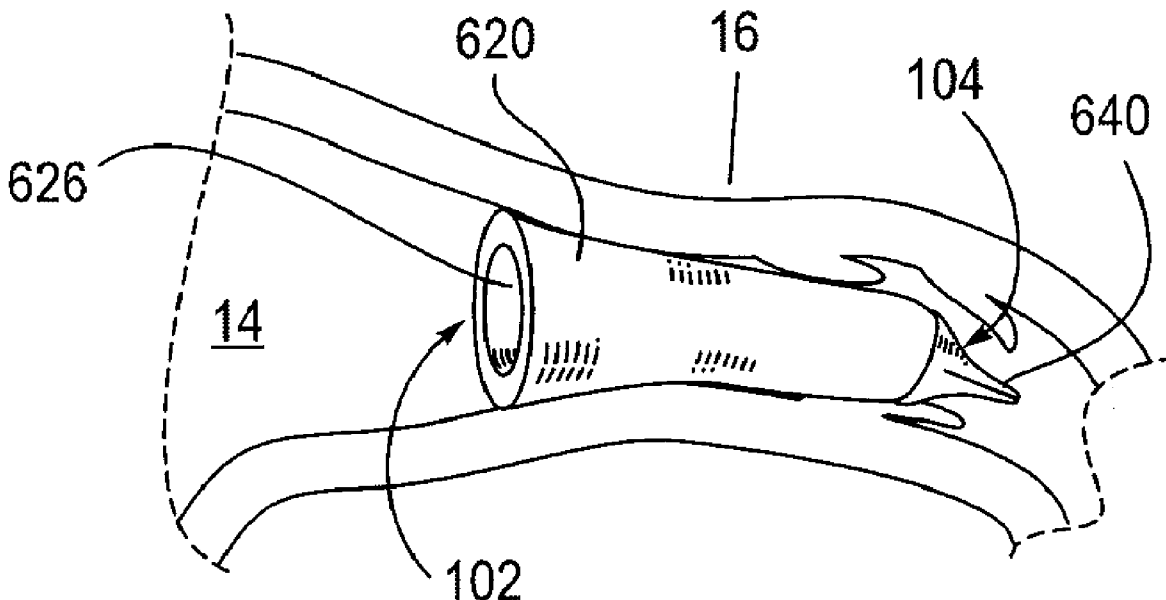

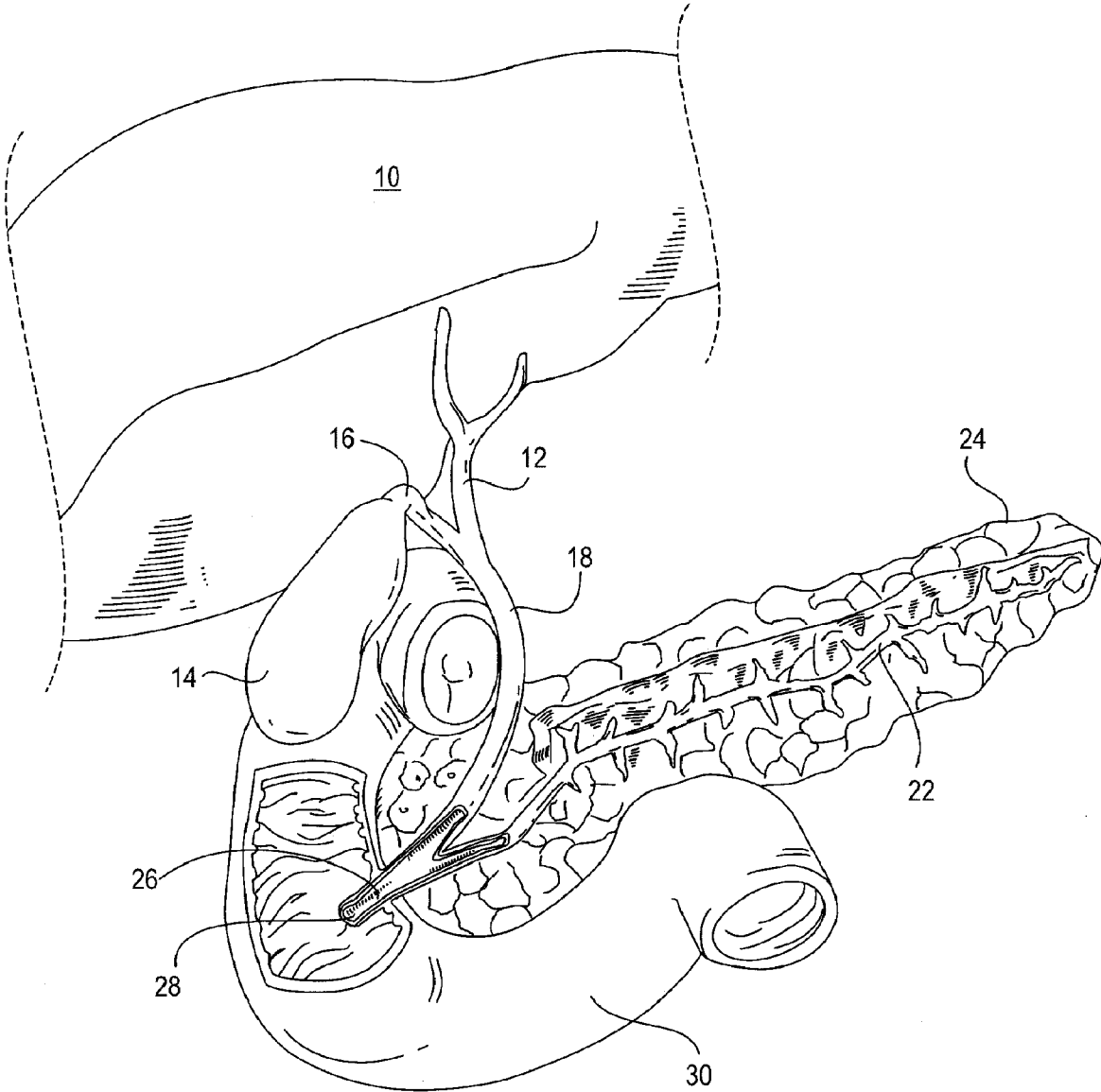

FIG. 1

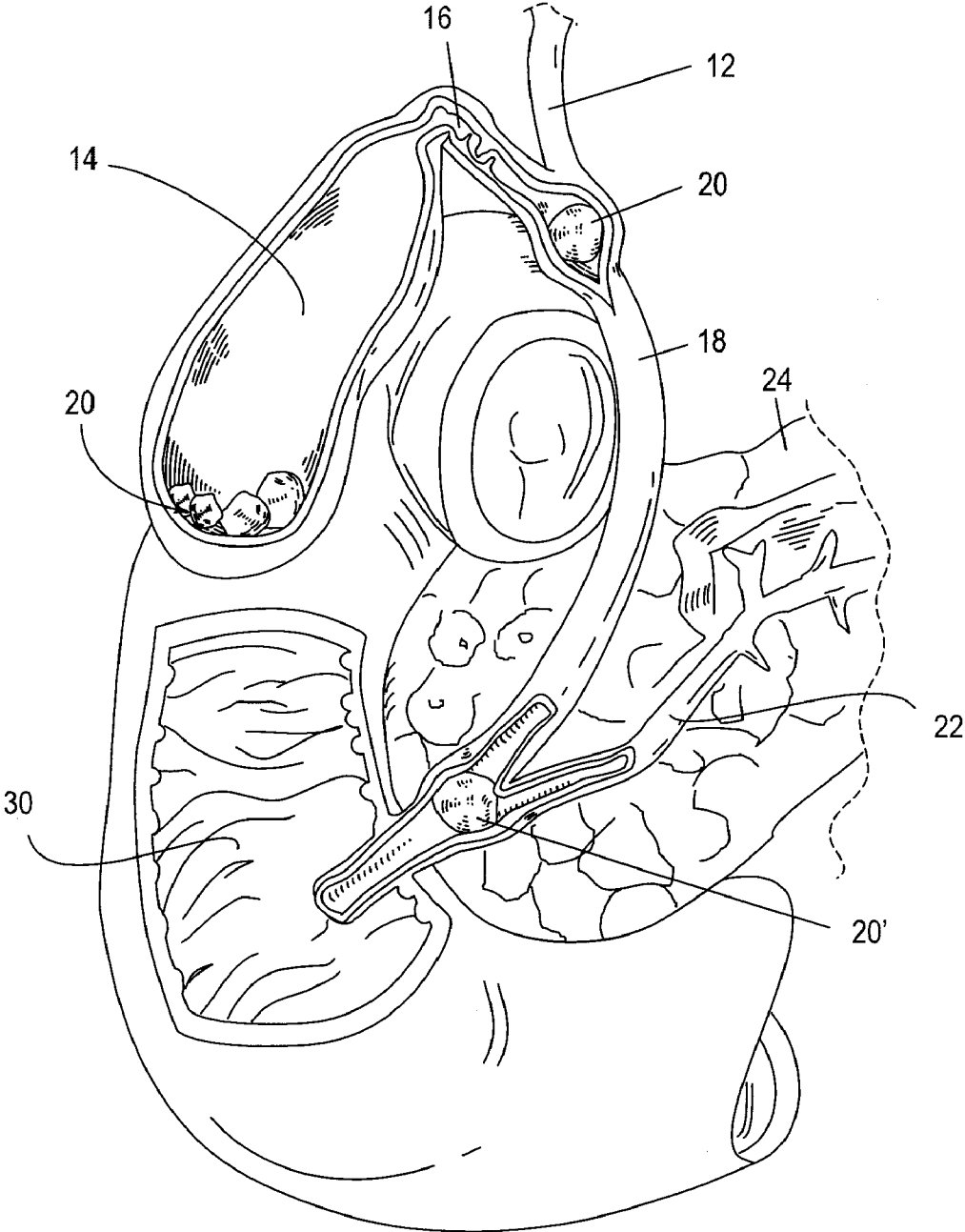

FIG. 2

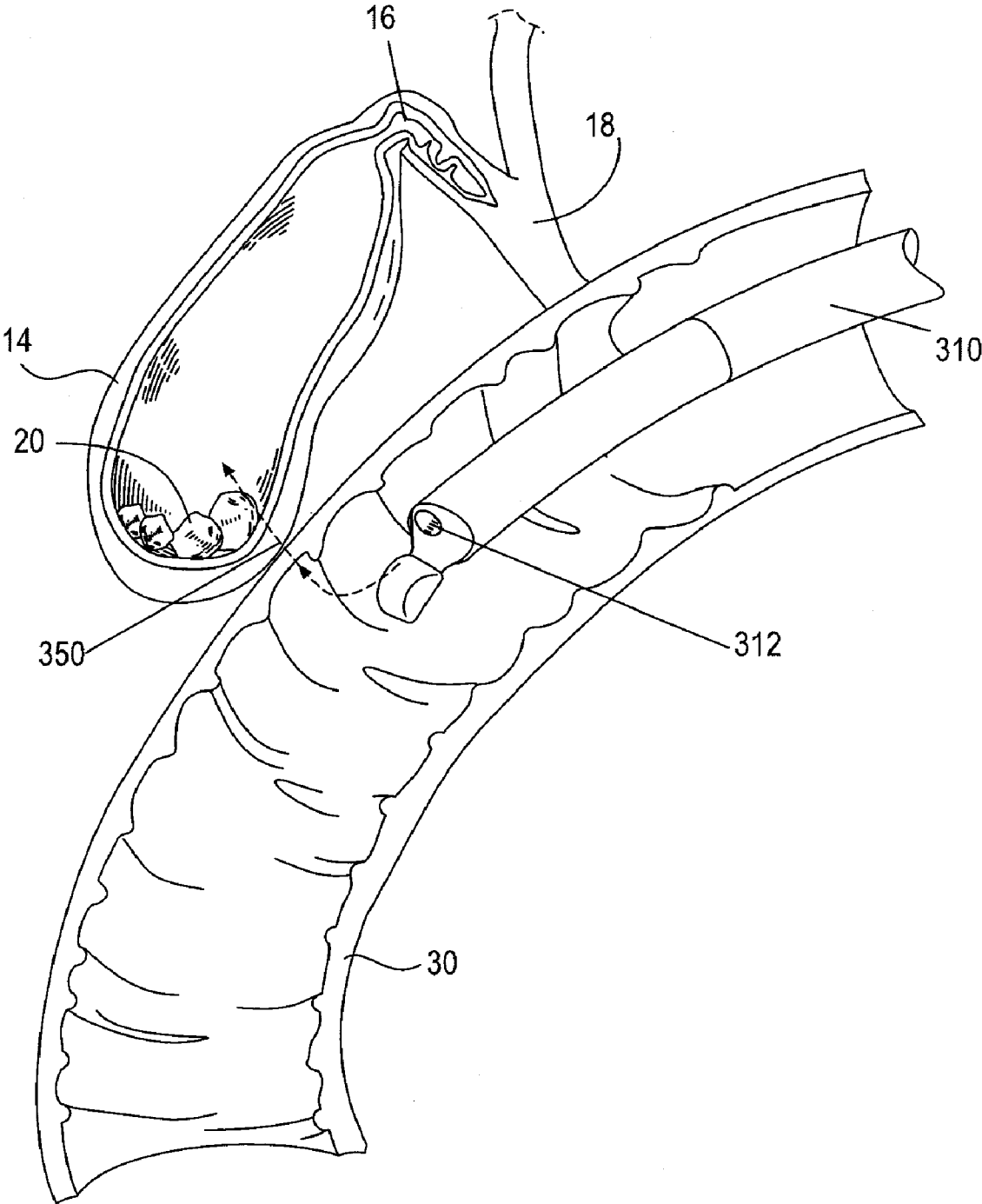

FIG. 3

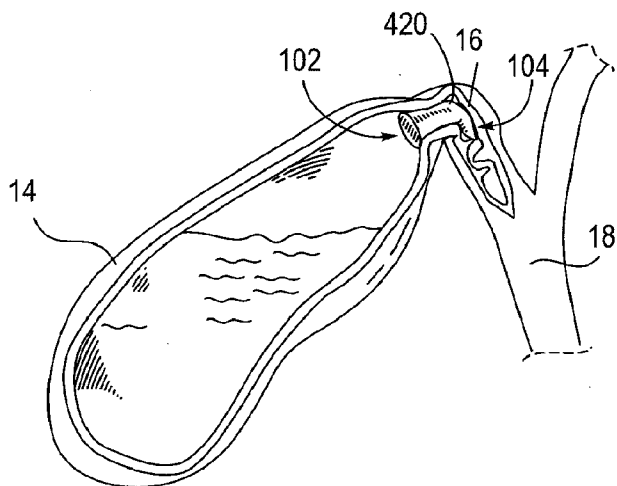

FIG. 4A

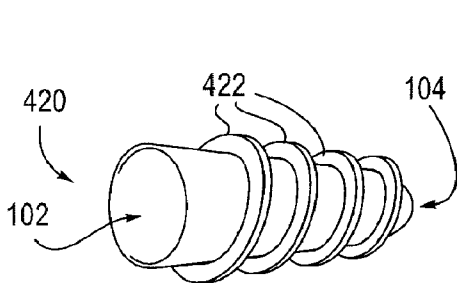

FIG. 4B

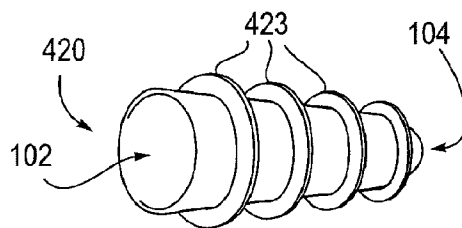

FIG. 4C

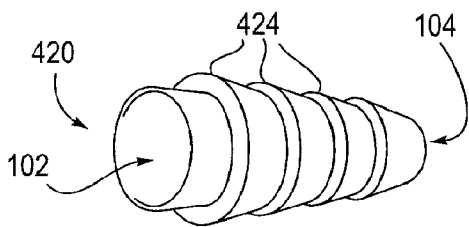

FIG. 4D

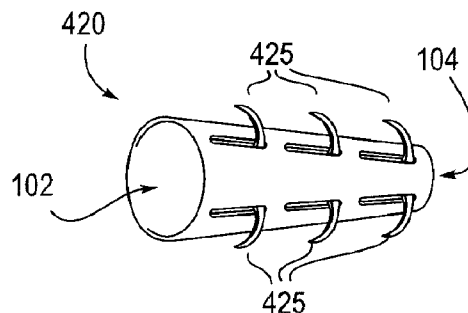

FIG. 4E

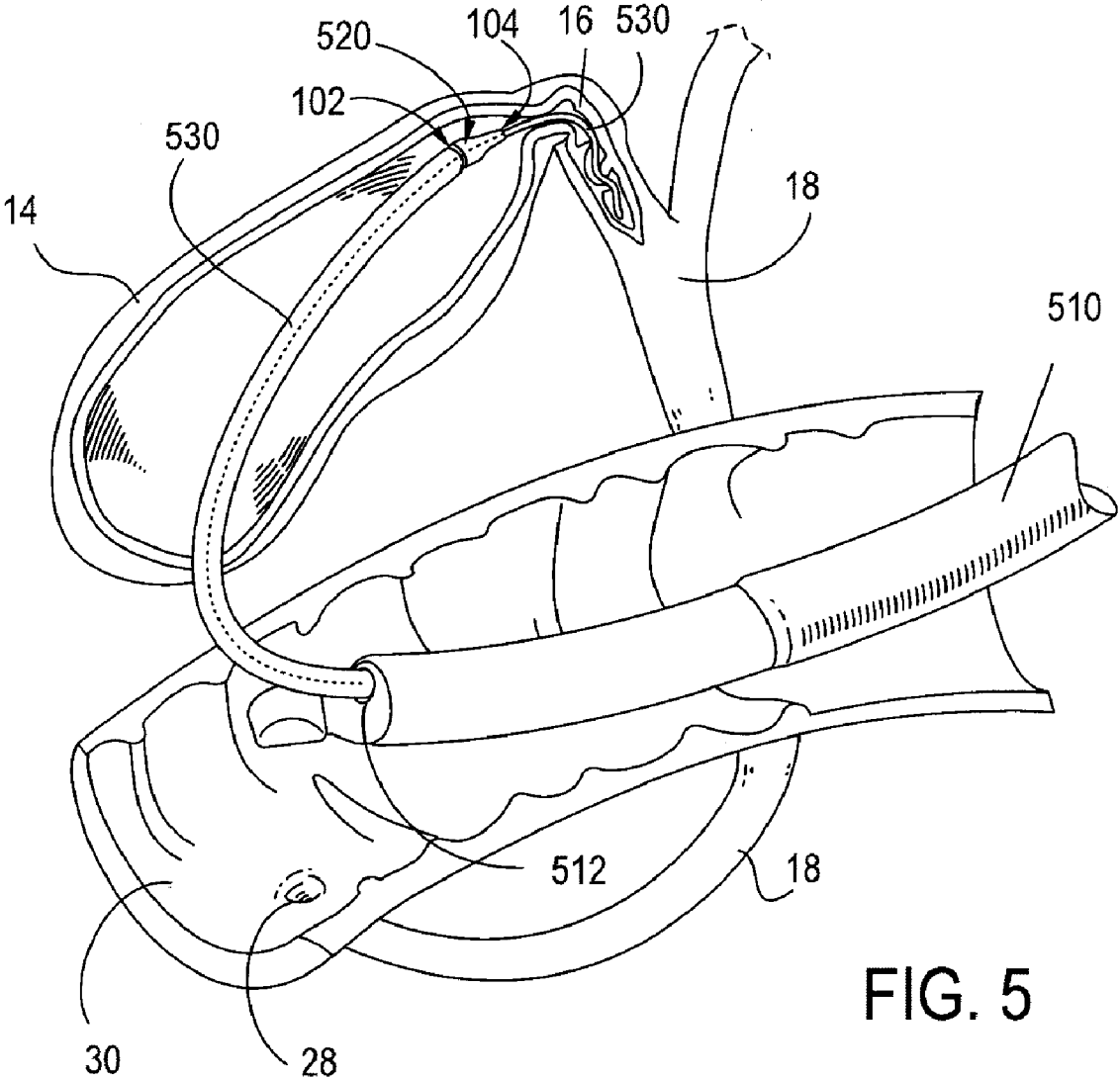

FIG. 5

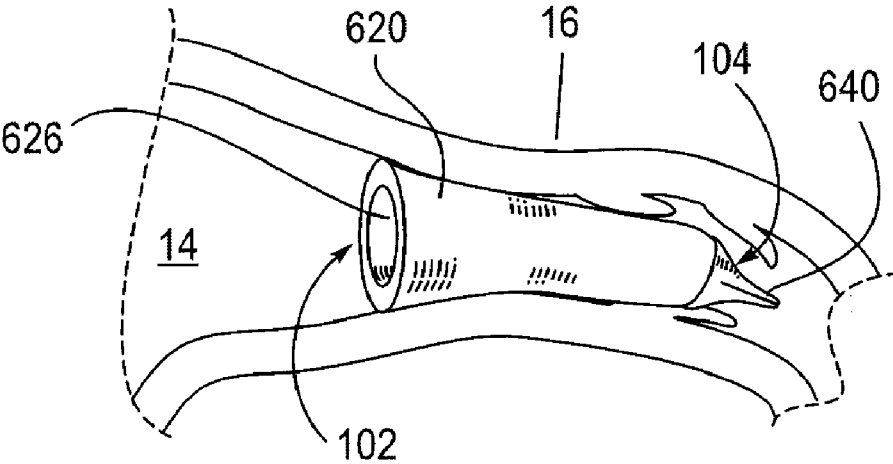

FIG. 6

METHODS, DEVICES, KITS AND SYSTEMS FOR DEFUNCTIONALIZING THE CYSTIC DUCT

CROSS-REFERENCE

[0001] This application claims the benefit of U.S. Provisional Application No. 60/991,682, filed Nov. 30, 2007, and Application No. 61/033,368 filed Mar. 3, 2008, which application is incorporated herein by reference.

[0002] This application has related subject matter to U.S. Utility patent application Ser. No. 12/_____, filed Nov. _____, 2008, entitled "Methods, Devices, Kits and Systems for Defunctionalizing the Gallbladder" by Jacques Van Dam, J. Craig Milroy, and R. Matthew Ohline (identified as Attorney Docket No. 36233-701.202) and U.S. Utility patent application Ser. No. 12/_____, filed Nov. _____, 2008, entitled, "Biliary Shunts, Delivery Systems, Methods of Using the Same, and Kits Therefor" by Jacques Van Dam, J. Craig Milroy, and R. Matthew Ohline (identified as Attorney Docket No. 36233-701.201), which applications are incorporated herein by reference.

FIELD OF THE INVENTION

[0003] The invention described in this patent application addresses challenges confronted in the treatment of biliary disease. Biliary disease includes conditions affecting the gallbladder, cystic duct, and common bile duct.

BACKGROUND OF THE INVENTION

Biliary System Function and Anatomy

[0004] Bile is a greenish-brown digestive fluid produced by the liver 10 illustrated in FIG. 1, and is vital for the digestion of fatty foods. Bile is secreted by liver cells and collected by a network of ducts that converge at the common hepatic duct 12. While a small quantity of bile drains directly into the lumen of the duodenum 30 (the section of small intestine immediately downstream of the stomach), most travels through the common hepatic duct 12 and accumulates in the lumen of the gallbladder 14. Healthy gallbladders are pear-shaped sacs with a muscular wall that, on average, measure 10 cm in length and can store approximately 50 ml of fluid within its lumen. When fatty foods are ingested, the hormone cholecystokinin is released, which causes the gallbladder 14 to contract. Contraction of the gallbladder 14 forces bile to flow from the gallbladder 14, through the cystic duct 16, into the common bile duct 18, out the papilla 28, and finally into the duodenum 30 of the small intestine. Here, it mixes and reacts with the food that exits the stomach. The Sphincter of Oddi 26 controls secretions from the liver, pancreas 24, and gallbladder 14 into the duodenum 30 of the small intestine. The opening on the inside of the descending duodenum 30 after the Sphincter of Oddi 26 is called the major duodenal papilla 28 (of Vater). Together, the biliary ducts, the gallbladder 14, the cystic duct 16 and the common bile duct 18 comprise the biliary system (FIG. 1).

[0005] The pancreas 24 is a gland organ in the digestive and endocrine system of vertebrates. It is both an endocrine gland (producing several important hormones, including insulin, glucagon, and somatostatin), as well as an exocrine gland, secreting pancreatic juice containing digestive enzymes that pass to the small intestine. These enzymes help in the further breakdown of the carbohydrates, protein, and fat in the

chyme. The pancreatic duct 22, or duct of Wirsung, is a duct joining the pancreas 24 to the common bile duct 18 to supply pancreatic juices which aid in digestion provided by the exocrine pancreas. The pancreatic duct 22 joins the common bile duct 18 just prior to the major duodenal papilla 28, after which both ducts perforate the medial side of the second portion of the duodenum 30 at the major duodenal papilla.

Biliary Disease:

[0006] The most common problem that arises in the biliary system is the formation of gallstones, a condition called cholelithiasis. Approximately 20 million Americans have gallstones, and about 1-3% will exhibit symptoms in any given year. In the U.S., gallstones are more common among women, with 25% of women having gallstones by the age of 60 and 50% by the age of 75. Pregnancy and hormone replacement therapy increase the risk of forming gallstones. Prevalence is lower for American men: approximately 25% will develop gallstones by the age of 75. In the U.S., gallstones are responsible for the highest number of hospital admissions due to severe abdominal pain.

[0007] Gallstones 20, 20' are most often composed of cholesterol, but may also be formed from calcium bilirubinate, in which case they are called pigment stones. They range in size from a few millimeters to several centimeters, and are irregularly shaped solids resembling pebbles. They can form in the gallbladder 14, cystic duct 16, and/or the common bile duct 18 (FIG. 2). By themselves, gallstones 20 do not necessarily result in disease states. This is the case 90% of the time. However, stones can cause infection and inflammation, a condition known as cholecystitis, which is generally the result of restricting or blocking the flow of bile from the gallbladder 14 and common bile duct 18, or the fluids secreted by the pancreas 24.

[0008] Gallbladder disease may be chronic, and patients who suffer from this may periodically experience biliary colic. Symptoms include pain in the upper right abdomen near the ribcage, nausea, and/or vomiting. The pain may resolve within an hour of onset, may prove unresponsive to over-the-counter medicines, and may not decrease with changes of position or the passage of gas. Recurrence is common, with pain often recurring at the same time of day, but with frequency of less than once per week. Fatty or large meals may cause recurrence several hours after eating, often awakening the patient at night. Patients may elect to suffer from these symptoms for very long periods of time, such as years or even decades.

[0009] Patients with chronic cholecystitis have gallstones and low-grade inflammation. Untreated, the gallbladder 14 may become scarred and stiff over time, leading to a condition called dysfunctional gallbladder. Patients who have chronic cholecystitis or dysfunctional gallbladder may experience gas, nausea, and abdominal discomfort after meals, and chronic diarrhea.

[0010] Acute cholecystitis (a surgical emergency) develops in 1-3% of those with symptomatic gallstone disease, and is due to obstruction of the common bile duct 18 or cystic duct 16 by stones or sludge. Symptoms are similar to biliary colic, though they are more severe and persistent. Pain in the upper right abdomen can be constant and severe, the intensity may increase when drawing breath, and it may last for days. Pain may radiate to the back, under the breastbone or the shoulder blades, and it may be perceived on the left side of the abdomen. In addition to nausea and vomiting, one third of patients

experience fever and chills. Complications from acute cholecystitis can be serious and life threatening, and include gangrene, abscesses, perforation of the gallbladder **14** which can lead to bile peritonitis, pus in the gallbladder wall (empyema), fistulae, and gallstone ileus (when a gallstone creates a blockage in the small intestine).

[0011] When gallstones **20'** become lodged in the common bile duct **18** (FIG. 2), the condition is known as choledocholithiasis. Symptoms for this condition include pain, nausea and vomiting, and some patients develop jaundice, have dark urine and/or lighter stools, rapid heartbeat, and experience an abrupt drop in blood pressure. These symptoms can also be accompanied by fever, chills, and/or severe pain in the upper right abdomen. Complications from choledocholithiasis can also be very serious, and include infection of the common bile duct **18** (cholangitis) and inflammation of the pancreas **24** (pancreatitis).

[0012] A smaller patient population suffers from gallbladder disease that occurs in the absence of gallstones. This condition, called acalculous gallbladder disease, can also be chronic or acute. Chronic acalculous gallbladder disease, also called biliary dyskinesia, is thought to be caused by motility disorders that affect the gallbladder's ability to store and release bile. Acute acalculous gallbladder disease occurs in patients who suffer from other serious illnesses which can lead to inflammation of the gallbladder **14** because of a reduction in the supply of blood to the gallbladder **14** or a reduced ability to contract and empty bile into the duodenum **30**.

[0013] Cancer can also develop in the gallbladder **14**, though this condition is rare. Gallstones have been found in 80% of patients with gallbladder cancer. Gallbladder cancer typically develops from polyps, which are growths inside the gallbladder **14**. When polyps 15 mm across or larger are observed, the gallbladder is removed as a preventive measure. Polyps smaller than 10 mm are widely accepted as posing low risk and are not generally removed. When detected early, before the cancer has spread beyond the mucosa (inner lining) of the gallbladder, the 5-year survival rate is approximately 68%. However, gallbladder cancer is not usually detected until patients are symptomatic, by which time the disease is more advanced.

Treatment of Biliary Disease:

[0014] The most effective treatment for biliary disease has been surgical removal of the gallbladder **14**, a procedure called cholecystectomy. Surgical removal of the gallbladder **14** is indicated for patients who experience a number of less severe gallstone attacks, cholecystitis, choledocholithiasis, pancreatitis, acalculous biliary pain with evidence of impaired gallbladder **14** emptying, those at high risk for developing gallbladder cancer, and those who have previously undergone endoscopic sphincterotomy for common bile duct stones. Other treatment modalities exist and are frequently used, but gallbladder disease tends to recur in the majority of patients who forgo cholecystectomy and pursue alternatives. Removal of the gallbladder **14** is highly successful at permanently eliminating biliary disease. Cholecystectomy is one of the most commonly performed procedures on women. The gallbladder **14** is not an essential organ, and after a period of adjustment post surgery, patients tend to return to more or less normal digestive function.

[0015] Cholecystectomy can be performed either as open surgery, which requires a single larger incision in the upper right abdomen, or laparoscopic surgery, in which several

small instruments are inserted through much smaller incisions in the abdomen. Approximately 80% of cholecystectomies are performed laparoscopically. The primary benefits of this minimally invasive approach are faster recovery for the patient, and a reduction in overall healthcare costs. Patients who receive laparoscopic cholecystectomy are usually released the same day. By contrast, patients receiving open cholecystectomies typically spend 5-7 days in a hospital before release. 5-10% of laparoscopic procedures convert to open procedures when difficulties arise, such as injury to major blood vessels, inadequate access, inadequate visualization, previous endoscopic sphincterotomy, and thickened gallbladder wall. Complications from cholecystectomy (open or laparoscopic) include bile duct injuries (0.1-0.5% for open, 0.3-2% with a declining trend for laparoscopic), pain, fatigue, nausea, vomiting, and infection. In up to 6% of cases, surgeons fail to identify and remove all gallstones present.

[0016] In some cases, the degree of infection and inflammation prevents patients from undergoing immediate cholecystectomy. In these cases, the gallbladder **14** must be treated with antibiotics and anti-inflammatory agents, and drained through a tube into a reservoir outside the abdomen. Placement of this tube occurs in a procedure called percutaneous cholecystostomy, in which a needle is introduced to the gallbladder **14** through the abdomen, fluid is withdrawn, and a drainage catheter is inserted. This catheter drains into an external bag which must be emptied several times a day until the tube is removed. The drainage catheter may be left in place for up to 8 weeks. In cases where no drainage catheter is inserted, the procedure is called gallbladder aspiration. Since no indwelling catheter is placed, the complication rate for gallbladder aspiration is lower than that of percutaneous cholecystostomy.

[0017] Treatment methodologies other than cholecystectomy include expectant management, dissolution therapy, endoscopic retrograde cholangiopancreatography (ERCP) with endoscopic sphincterotomy, and extracorporeal shock-wave lithotripsy (ESWL).

[0018] Expectant management is appropriate for patients who have gallstones but no symptoms, and for non-emergency cases with less severe symptoms. This approach is not recommended when patients are in high risk categories (e.g. high risk for gallbladder cancer) or have very large gallstones (e.g. greater than 3 cm).

[0019] Oral dissolution therapy involves the administration of pills containing bile acids that can dissolve gallstones. This approach is only moderately effective, and the rate of recurrence of gallstones after completion of treatment is high. It is not appropriate for patients with acute inflammation or stones in the common bile duct (more serious conditions). Dissolution therapy tends to be more effective for patients with cholesterol stones, and is sometimes used in conjunction with lithotripsy. Despite its relative ineffectiveness, it is costly: treatment can last up to 2 years and the drugs cost thousands of dollars per year.

[0020] Related to oral dissolution therapy is contact dissolution, a procedure that involves injection of a solvent such as methyl tert-butyl ether (MTBE) directly into the gallbladder **14**. This approach is highly effective at dissolving gallstones, but patients may experience severe burning pain.

[0021] ERCP (endoscopic retrograde cholangiopancreatography) is a procedure in which an endoscope is introduced through the mouth of a patient, past the stomach to the papilla **28**, where the common bile duct **18** empties into the duode-

num 30. The overall goal of the procedure is to insert instruments and tools into the common bile duct 18 via the papilla 28 in order to treat biliary disease. Typically, endoscopic sphincterotomy is performed, which is a procedure that enlarges the opening of the papilla 28 in the small intestine. This can be accomplished surgically or via balloon dilation. Contrast agent is introduced into the common bile duct 18 to visualize the biliary tree fluoroscopically. Tools for clearing blockages, such as mechanical lithotripsy devices, can be deployed to crush gallstones and remove the resulting debris. Drainage catheters and stents may also be inserted to facilitate the drainage of bile past obstructions. Complications from this challenging procedure occur at a rate of 5-8%, and include recurrence of stone formation, pancreatitis, infection, bleeding, and perforation.

[0022] Extracorporeal shockwave lithotripsy (ESWL) is a technique in which focused, high-energy ultrasound is directed at the gallbladder 14. The ultrasound waves travel through the soft body tissue and break up the gallstones. The resulting stone fragments are then usually small enough to pass through the bile duct into the small intestine. Oral dissolution therapy is often used in conjunction with ESWL. This treatment is not in common use, as less than 15% of the patient population are good candidates. However, ESWL is used to treat patients who are not candidates for surgery. Complications from ESWL include pain in the gallbladder area, pancreatitis, and failure of the gallstone fragments to pass into the small intestine.

SUMMARY OF THE INVENTION

[0023] Devices for treating biliary disease are disclosed. Suitable devices comprise, for example, a component configurable for placement within a cystic duct of a biliary system of a patient which has a proximal end 102 and a distal end 104. In some aspects, a means adaptable for positioning within a lumen of a cystic duct of a biliary system of a patient is provided which has a proximal end and a distal end. Devices can further comprise a delivery mechanism for delivering a substance, such as bioresorbable materials or activatable materials. The means for positioning within a lumen can further provide, for example, a means for delivering a substance, such as bioresorbable materials or activatable materials. In some instances, the devices are adaptable and configurable to be removable. Additionally, or alternatively the device are adaptable and configurable to be expandable. Moreover, the devices can be configurable such that the device can achieve one or more configurations, such as a deployment configuration, a delivery configuration and a final configuration. In some embodiments, devices comprise a variable profile, for example, the device can be configurable to be variable along a cross-sectional area of the device. In some aspects, the devices are configurable for deployment by, for example, an endoscope, or by a guidance element such as a guidewire or guidance catheter. In other aspects a lumen can be provided that is configurable to provide restrictable fluid flow, for example by using one or more fluid control components. Devices can also be configured to comprise a valve. Suitable valves include, for example, a flow-restrictor valve or a one-way valve. Moreover, a means for controlling a material can be provided, such as a valve, including, for example, a flow-restrictor valve or a one-way valve. In some configurations of the device it may be desirable for the device to be flexible.

[0024] Still another aspect is directed to a biliary disease treatment device comprising: an implant adapted to be delivered by an endoscope, or guidance element such as a guidewire or guidance catheter to a gastrointestinal site in proximity to a gallbladder, and further adapted to form a conduit between the gastrointestinal site and the gallbladder. Devices can further comprise a delivery mechanism for delivering a substance, such as bioresorbable materials or activatable materials. In some instances, the devices are adaptable and configurable to be removable. Additionally, or alternatively the device are adaptable and configurable to be expandable. Moreover, the devices can be configurable such that the device can achieve one or more configurations, such as a deployment configuration, a delivery configuration and a final configuration. In some embodiments, devices comprise a variable profile, for example, the device can be configurable to be variable along a cross-sectional area of the device. In some aspects, the devices are configurable for deployment by, for example, an endoscope, or by a guidance element such as a guidewire or guidance catheter. In other aspects the lumen is configurable to provide restrictable fluid flow, for example by using one or more fluid control components. Devices can also be configured to comprise a valve. Suitable valves include, for example, a flow-restrictor valve or a one-way valve. In some configurations of the device it may be desirable for the device to be flexible.

[0025] Yet another aspect is directed to a biliary disease treatment device comprising: an implant adaptable to be delivered by percutaneous means, to a gastrointestinal site in proximity to a gallbladder, and further adapted to form a conduit means between the gastrointestinal site and the gallbladder. Percutaneous means includes, for example, guidewire, guiding catheter or endoscope.

[0026] Aspects of the invention also include methods of delivering a device to treat biliary disease. The methods of device delivery comprise, for example, using an endoscope to place guidance element, such as a guidewire or guidance catheter, between an access lumen and a gallbladder; inserting a delivery catheter over the guidance element and into the gallbladder; delivering a cystic duct defunctionalizing device on the guidance element; and positioning the cystic duct defunctionalizing device within a cystic duct. Additional method steps can include the step of passively retaining a distal end of the guidewire in the gallbladder while the guidewire is used to deliver additional elements. Moreover, the method can include the step of retaining a distal end of the guidewire within the gallbladder, retaining a distal end of the guidewire within the cystic duct, and/or retaining a distal end of the guidewire within the common bile duct. Additionally, gallstones can be removed through the created lumen, if desired. Additionally, in some instances, the method can include the step of localizing the gallbladder via endoscopic ultrasound and/or altering or altering and removing gallstones. It will be appreciated by those skilled in the art, that in some instances, it may be desirable to clear obstructions within the gallbladder. Moreover, it will be appreciated that the methods involved herein facilitated treatment of biliary disease without removal of the gallbladder. In still other methods, it may be desirable to also visualize a treatment area, before, during, or after any of the other method steps. In still other methods, a biological duct can be formed in situ from a patient's tissue. Moreover, the cystic duct defunctionalizing device can be changed, if desired, from a delivery configuration to a deployment configuration, from a delivery configuration

ration to a final configuration, and/or from a deployment configuration to a final configuration. In still other aspects of the method, a cross-sectional profile of the cystic duct defunctionalizing device can be reduced. In other aspects, a valve can be operated to restrict fluid flow. In some instances it may be desirable to defunctionalize the cystic duct in situ. Such defunctionalizing can be achieved by, for example, delivering a substance into a space within the cystic duct. As will be appreciated by those skilled in the art, a wide range of substances can be delivered, including, for example, gels, foams, sclerosing agents, adhesives, bioadhesives, anti-inflammatory and inflammatory agents. Moreover, some substances can be selected that are capable of activation in situ. The amount of substance delivered can vary, as desired, and can include delivering an amount sufficient to fill, or substantially fill, the lumen of the cystic duct, or in the case of an activatable substance, an amount sufficient to result in an activated substance amount sufficient to fill, or substantially fill, the lumen of the cystic duct. In other aspects of the method, the step of defunctionalizing the cystic duct is achievable by delivering a plug or device into a space, or lumen, within the cystic duct. Suitable plugs may be configurable either internally or externally to seat within the lumen of the cystic duct. Moreover plugs or devices can further comprise one or more thread profiles, ridges or steps about its exterior surface adapted to aid in seating the device within the lumen of the duct. The plugs or devices can further comprise a valve.

[0027] Another aspect of the invention is directed to a kit for treating biliary disease. Kits include, for example, one or more devices configurable to be positioned within a cystic duct; and optionally a compound for delivery to a tissue. Other components of the kit include, one or more of, a catheter, a guidewire, an ablation device, a sclerosing agent, antibiotic agents, inflammatory agents, anti-inflammatory agents, biocompatible gels, biocompatible foams, activatable materials, scissors, scalpels, swabs, syringes, hemostats, lubricants, needles, snares, antiseptics, and anesthetics.

[0028] Still another aspect of the invention is directed to a method of treating biliary disease comprising: accessing a lumen associated with a gallbladder; defunctionalizing a cystic duct. An aspect of the method enables the gallbladder to be left in situ. Additionally, the step of defunctionalizing the cystic duct can further comprise the step of delivering a substance to at least one of the cystic duct or the gallbladder. An amount of substance can be delivered such that it occupies, or substantially occupies the lumen, or is activated to occupy or substantially occupy the lumen of the cystic duct. One or more suitable substances can be delivered including, for example, antibiotics, inflammatory agents, and anti-inflammatory agents. In some instances, the method includes the step of preventing bile from entering the gallbladder lumen. Additionally, the method can include the step of localizing the gallbladder via endoscopic ultrasound. In other aspects of the method, the step of accessing the gallbladder is achieved via the gastrointestinal tract, such as by accessing the gastrointestinal tract at a duodenum. Additional aspects of the method include, for example, one or more of sclerosing, necrotizing or ablating tissue. Ablation techniques can, for example, be selected from the group comprising cryoablation, thermal ablation, chemical ablation, radio frequency ablation, ultrasound ablation, and microwave ablation. In some instances, a fluid can be delivered wherein the fluid is delivered, for example, with an angular orientation, moreover fluid can be delivered with at least one of a 360 degree radial pattern, a

sharp stream, and a cone shape. Still further, the fluid can be delivered with a device comprising an articulating member or a means for articulating. In some aspects of the method it may be desirable to apply a vacuum to a lumen of the cystic duct or the gallbladder, and/or apply an adhesive to the lumen of the cystic duct. Additionally, in some instances the step of defunctionalizing the cystic duct may further comprise physically blocking a lumen of the cystic duct, such as with a plug, device, means for blocking or means for plugging.

[0029] Yet another aspect of the invention is directed to a device for treating biliary disease comprising a plug, device, means for blocking or means for plugging, adaptable and configurable to be positioned within a cystic duct of a patient having a proximal end and a distal end and is configurable either internally or externally to seat within a lumen of the cystic duct after deployment. The external configuration of the plug, device, or plugging means can be configurable to have one or more of threads, ridges, steps, or means for securing. Moreover, the ridges, steps or means for securing can be fixed or activatable. Additionally, the plug, device or plugging means can further comprise a valve, such as a one-way valve, or means for controlling or restricting a flow of fluid or flowable material. In some aspects the plug, device or plugging means can be positioned within or proximal to the cystic duct.

[0030] Another aspect of the invention is directed to the use of any of the devices disclosed herein for use in the treatment of biliary disease.

INCORPORATION BY REFERENCE

[0031] All publications, patents, and patent applications mentioned in this specification are herein incorporated by reference to the same extent as if each individual publication, patent, or patent application was specifically and individually indicated to be incorporated by reference.

BRIEF DESCRIPTION OF THE DRAWINGS

[0032] The novel features of the invention will be set forth with particularity in any claims presented based on this application. A better understanding of the features and advantages of the present invention will be obtained by reference to the following detailed description that sets forth illustrative embodiments, in which the principles of the invention are utilized, and the accompanying drawings of which:

[0033] FIG. 1 illustrates an overview of the biliary system;

[0034] FIG. 2 illustrates the biliary system with gallstones;

[0035] FIG. 3 illustrates an endoscope accessing the biliary system via the intestinal system;

[0036] FIGS. 4A-E illustrate cystic duct defunctionalization devices;

[0037] FIG. 5 illustrates a cystic duct defunctionalization device in combination with a guidewire; and

[0038] FIG. 6 illustrates a cystic duct plug with 1-way valve.

DETAILED DESCRIPTION OF THE INVENTION

[0039] Devices, systems, methods and kits provided herein can obviate the need for a plurality of procedures, including, for example: 1) percutaneous cholecystostomy, 2) cholecystectomy, 3) percutaneous trans-hepatic cholangiography (PTHC), and 4) endoscopic retrograde cholangiopancreatography (ERCP). Additionally, disclosed treatment modalities enable treatment of a distal common bile duct obstruction,

e.g. secondary to pancreatic carcinoma, cholangiocarcinoma, and/or ampullary carcinoma. As will be appreciated by those skilled in the art, the conventional standard of care for treating biliary disease has been surgical removal of the gallbladder **14** and closure of the cystic duct **16**. While this has proven to be an effective mechanism for permanently eliminating biliary disease and its recurrence, the present invention seeks to accomplish the same end in a less invasive and less costly way. This may be achieved by treating biliary disease without requiring the removal of the gallbladder **14**. Methods and apparatus are described in this application that are intended to effectively treat biliary disease with the gallbladder **14** and cystic duct **16** left in situ by defunctionalizing the cystic duct.

Defunctionalization of the Cystic Duct:

[0040] In order to treat gallbladder **14** disease while leaving the gallbladder **14** in situ, it may be desirable to defunctionalize the cystic duct **16**. The cystic duct **16** connects the gallbladder **14** and the common bile duct **18** (see FIG. 1), and is the flow path for bile into and out of the gallbladder **14**. An objective of defunctionalizing the cystic duct **16** is to prevent bile from reaching the gallbladder **14**. The gallbladder **14** may be otherwise unaltered, or it may be altered—e.g. a conduit or shunt may be placed for access and/or drainage, the gallbladder **14** may be defunctionalized, etc. When bile is unable to enter the cystic duct **16**, and therefore the gallbladder **14**, the gallbladder **14** will also be effectively defunctionalized, whether or not any other treatment is performed. Gallstones may form anywhere that bile is present in the biliary system, so preventing bile from flowing in the cystic duct **16** may prevent the formation of gallstones in the cystic duct **16** and gallbladder **14**. Defunctionalization of the cystic duct **16** may be long- or short-term, temporary or permanent. The entire length of the cystic duct **16** may be defunctionalized, or it may be performed at one or more discrete locations. The treatment may be applied anywhere along the length of the cystic duct **16**, from the point where it joins the common bile duct **18** to the point where it interfaces with the gallbladder **14**. However, the preferred treatment location for defunctionalizing the cystic duct **16** is as close to the junction with the common bile duct **18** as possible without substantially affecting the function of the common bile duct **18**.

[0041] In holding with the other methods and apparatus described in this application, it is most desirable to effect defunctionalization of the cystic duct **16** from within the gallbladder **14**, inside the cystic duct **16**, and/or inside the common bile duct **18**. This eliminates the need for external, surgical access to these anatomical structures. Optionally, defunctionalization of the cystic duct **16** is achieved by the use of implements delivered endoscopically or means for accessing the cystic duct percutaneously. In some instances, directly visualizing the devices and navigational devices used may also be desirable, and may facilitate control and treatment. Visualization may be achieved by any suitable mechanism known in the art, including, for example, endoscopic ultrasound (EUS), or by using a small daughter endoscope (e.g. a cystoscope), or by using catheters incorporating small imaging sensors at the distal end (e.g. Avantis' Third Eye) and fiber optic imaging bundles (e.g. Boston Scientific's Spy-Glass). Visualization and guidance may also be achieved via external imaging methods, such as fluoroscopy (with or without the use of contrast agent), ultrasound, X-ray, etc.

[0042] Defunctionalization of the cystic duct **16** may be accomplished by a variety of mechanisms, including, but not

limited to, ablation methods (e.g. cryo-, thermal-, RF, microwave, ultrasound, etc.) and mechanical methods (e.g. plugs, stoppers, sutures, staples, clamps, clips, adhesives, bioadhesives, vacuum with adhesives/bioadhesives, vacuum without adhesives/bioadhesives, etc.). Regardless of the method used, it may be helpful to begin the process by inserting a guidance element **530**, such as a guidewire, guidance catheter or any suitable means for accessing the cystic duct **16** from within the gallbladder **14**, though a conduit that connects the gallbladder **14** lumen to the access lumen, e.g. at or near the duodenum **30**, or from within the common bile duct **18**, as may be done during ERCP. A guidance element **530** (FIG. 5) (e.g. a guidewire, guidance catheter, etc.) may be useful for inserting and navigating items into the cystic duct **16**, such as ablation catheters, visualization catheters, mechanisms of treating gallstones within the cystic duct **16**, devices **520** for defunctionalizing the cystic duct **16**, and other mechanisms of defunctionalizing the cystic duct **16**. Since the cystic duct **16** is funnel-shaped (with a larger diameter at the opening into the gallbladder **14** than at the junction with the common bile duct **18**), and spirals as it progresses (an anatomical feature called the valves of Heister), it may be easily traversed with a guidance element **530**, such as a guidewire or guidance catheter, from within the gallbladder **14** simply by pushing. However, the guidance element **530** may be configured or configurable to facilitate advancement. Moreover, alternate shapes of the guidance element **530** may facilitate advancement, such as a cork-screw shape, spiral shape, or a tip that is preferentially bent to one side. In these cases, successfully advancing the guidance element **530** into the cystic duct **16** may be achieved by pushing, torquing (rotating), or a combination of pushing and torquing.

[0043] If defunctionalization is achieved by physically blocking the cystic duct **16**, a cystic duct defunctionalization device **420** serving a similar function as, for example, a bottle stopper may be used (FIG. 4A). The defunctionalization device **420** has a proximal end and a distal end. Such a device **420** may be inserted into the cystic duct **16** from the gallbladder **14**, through a conduit that connects the gallbladder **14** to an access lumen such as the duodenum **30**. The plug **420** may be inserted before, during, or after other treatments for inflammation, infection, gallstones, etc. have been administered or completed. The plug **420** may be left in place for a limited period of time, or permanently. The plug **420** or means for plugging the cystic duct may be comprised of any suitable biocompatible material, such as silicone, polytetrafluoroethylene (PTFE), stainless steel, titanium, shape memory materials (e.g. Nitinol), etc. The device **420** may be configured or configurable to provide a means for blocking the cystic duct.

[0044] Devices **420** may optionally incorporate features that aid in retaining and securing the device in place. Such features may be inactive (that is, fixed and integral to or incorporated into the devices), e.g. a spiral thread pattern **422** (in which case, the devices should be rotated into position in the cystic duct **16** at installation, FIG. 4B), one or more ridges **423** (FIG. 4c), and/or one or more backward-facing steps **424** resembling a hose barb (FIG. 4D). Each of these one or more threads **422**, ridges **423**, and steps **424** features enable the device **420** to be secured within the cystic duct **14**. Alternately, the retaining features may be active **425** so that they may be activated once the device is in the desired position, e.g. with shape memory alloys (e.g. Nitinol) or with mechanically triggered movable elements (FIG. 4E).

[0045] Additionally, a plug or stopper device **620** may have one or more flow control elements, such as 1-way valves **640** which allow flow out of the gallbladder **14** and cystic duct **16**, but does not allow flow into the cystic duct **16** or gallbladder **14** (FIG. 6). This may be useful in cases where drainage of the gallbladder **14** and/or cystic duct **16** is desired, and provides either a primary or secondary flow path for fluids. Additionally, activatable materials can be delivered to the cystic duct. Suitable activatable materials include, for example, sclerosing substances, gels, foams, adhesives, bioadhesives. Any of such activatable materials may be selected so that they are absorbed or break down within the body over a desired period of time. Additionally, a vacuum may be applied to the cystic duct in order to close or substantially close it. This may be done in combination with the use of any of the other techniques described herein.

[0046] Since stones **20** may be present in the cystic duct **16** at the time of treatment, it may be necessary to eliminate them before, during, or after defunctionalization. This may be achieved using mechanical lithotripsy, snares, chemical/contact dissolution with substances such as methyl tertiary-butyl ether (MTBE), ultrasound energy, or any other useful or effective mechanism of breaking up and/or removing gallstones. Removal of gallstones through a conduit placed in the gallbladder **14** allows clinicians to access the cystic duct **16** from the reverse direction, which is not possible with conventional techniques. This may dramatically facilitate the process of treating gallstones **20** in the cystic duct **16** and common bile duct **18**, which can be difficult using conventional techniques.

[0047] A method of treating biliary disease involves using an endoscope **310** to access a region in the gastrointestinal (GI) tract to which the cystic duct **16** is in close proximity, locating the cystic duct **16**, accessing the cystic duct **16**, and then treating the underlying condition that led to the need for intervention (FIG. 3). Treatments may also include, but are not limited to: providing for drainage of the gallbladder **14** and/or the biliary tree, delivering antibiotics, inflammatory, anti-inflammatory agents (any of which may be short-term acting, fast acting, or time release), and/or other substances (e.g. adhesives, bioadhesives, etc.) and/or activatable materials to the gallbladder **14** and/or biliary tree, removing gallstones **20**, facilitating the destruction and subsequent removal of gallstones, clearing obstructions, delivering catheters, delivering stents (drug coated or not drug coated), temporarily or permanently defunctionalizing the cystic duct **16**, temporarily or permanently defunctionalizing the gallbladder **14**. Devices and therapies can be delivered in a single treatment, with minimal likelihood of or necessity for follow-up or repeat procedures.

[0048] Localization of the gallbladder **14** can be performed via endoscopic ultrasound (EUS) by accessing the wall of the GI tract with an endoscope **310** as shown in FIG. 3. Localization may also be achieved by any other method that visualizes anatomical features, such as fluoroscopy, x-rays, magnetic resonance imaging (MRI), computed axial tomography (CT) scans, ultrasound imaging from outside the body, or any method of anatomical imaging and visualization.

[0049] Once the gallbladder **14** has been located, it may be accessed and/or treated through the wall of the GI tract **350** (or any lumen in proximity to the gallbladder **14**) with tools and devices (e.g. needles, guidewires, guidance catheters, shunts, dilators, etc.) delivered through, for example, an endoscope **310**. Such tools and devices may be inserted down

the length of the endoscope's working channel **312**, or loaded onto or near the distal end of the endoscope **310**. Alternately, tools and other devices may be used that do not require the aid of the endoscope for navigation or delivery. Direct visualization may be provided by the endoscope **310** during the procedure, as well as irrigation, suction, and insufflation.

[0050] Though the preferred location for accessing the gallbladder lumen is the duodenum **30**, it may also be readily achieved through the wall of other regions of the GI tract, such as the stomach or the jejunum, for example. Thus, any lumen in close proximity to the gallbladder **14** is a candidate for access to and treatment of the gallbladder **14** and other members of the biliary system.

[0051] The devices and methods disclosed herein facilitate defunctionalizing the cystic duct without the need for surgery.

Kits:

[0052] All of the devices required to deliver and install a conduit, treat and/or defunctionalize the cystic duct **16**, may be packaged in a kit. Bundling all devices, tools, components, materials, and accessories needed to perform these procedures into a kit may enhance the usability and convenience of the devices, and also improve the safety of the procedure by encouraging clinicians to use the items believed to result in the best outcomes. The kit may be single-use or reusable, or it may incorporate some disposable single-use elements and some reusable elements. The kit may contain, but is not limited to, the following: implantable and/or non-implantable devices; delivery devices (e.g., needles, guidewires, guidance catheters, dilators, etc.); balloon inflation/deflation accessories; syringes; fluid flow, temperature, and pressure measurement instruments; scissors; scalpels; clips; ablation catheters; endoscopic tools (e.g. lithotripsy devices, snares, graspers, clamps, forceps, etc.). The kit may be supplied in a tray, which organizes and retains all items so that they can be quickly identified and used.

DESCRIPTION OF OTHER USES

[0053] The techniques and devices described in this application may prove beneficial in applications beyond their initial use in the treatment of biliary disease.

[0054] For example, they may prove to be an effective mechanism of treating cholangitis (infection of the common bile duct **18**). This condition is usually bacterial, and occurs when the bile duct is blocked by gallstones **20'** or a tumor. Traditional treatment involves the insertion of a stent or drainage catheter into the common bile duct **18** to allow bile to drain into the duodenum **30** from locations above the obstruction. Placement of a conduit into the gallbladder **14** may allow for an alternate method of draining bile and/or other fluids into the duodenum **30**. Any blockage in the common bile duct **18** between the entrance of the cystic duct **16** and the duodenum **30** may be treated in this way. See FIG. 2.

[0055] Another use of the devices and techniques described elsewhere in this application may be to create anastomoses between any body lumens in proximity to one another. This may include, but is not limited to: small bowel to small bowel anastomoses, small bowel to large bowel anastomoses, large bowel to large bowel anastomoses, and stomach to small bowel anastomoses. Additionally, creating a conduit between the stomach and other body lumens may be useful and effective for treating and/or managing obesity.

[0056] Another use of the devices and techniques described herein is for drainage of any body lumen into another body lumen in proximity, for example, the drainage of pancreatic pseudocysts.

[0057] While preferred embodiments of the present invention have been shown and described herein, it will be obvious to those skilled in the art that such embodiments are provided by way of example only. Numerous variations, changes, and substitutions will now occur to those skilled in the art without departing from the invention. It should be understood that various alternatives to the embodiments of the invention described herein may be employed in practicing the invention. It is intended that the following claims define the scope of the invention and that methods and structures within the scope of these claims and their equivalents be covered thereby.

1. A device for treating biliary disease comprising: a component configurable for placement within a cystic duct of a biliary system of a patient which has a proximal end and a distal end.

2. The device of claim 1 further comprising a delivery mechanism for delivering a substance.

3. The device of claim 1 wherein the device is formed from at least one of a bioresorbable material or an activatable material.

4. The device of claim 1 wherein the device is removable.

5. The device of claim 1 wherein the device is expandable.

6. The device of claim 1 further comprising one or more configurations selected from a deployment configuration, a delivery configuration and a final configuration.

7. The device of claim 6 further comprising a variable profile.

8. The device of claim 1 wherein a cross-sectional area of the device is variable along a length.

9. The device of claim 1 wherein the device is configurable for deployment by an endoscope.

10. The device of claim 1 wherein the device is configurable for deployment by a guidance element.

11. The device of claim 1 wherein a lumen is provided that is configurable to provide restrictable fluid flow.

12. The device of claim 10 further comprising one or more fluid control components.

13. (canceled)

14. (canceled)

15. The device of claim 1 wherein the device is flexible.

16. A biliary disease treatment device comprising: an implant adapted to be delivered by an endoscope, guidance element to a gastrointestinal site in proximity to a gallbladder, and further adapted to form a conduit between the gastrointestinal site and the gallbladder.

17. (canceled)

18. (canceled)

19. (canceled)

20. (canceled)

21. (canceled)

22. (canceled)

23. (canceled)

24. (canceled)

25. (canceled)

26. (canceled)

27. (canceled)

28. A method of delivering a device to treat biliary disease comprising:

a. using an endoscope to place a guidance element between an access lumen and a gallbladder;

b. inserting a delivery catheter over the guidance element and into the gallbladder;

c. delivering a cystic duct defunctionalizing device on the guidance element; and

d. positioning the cystic duct defunctionalizing device within a cystic duct.

29. (canceled)

30. (canceled)

31. (canceled)

32. (canceled)

33. (canceled)

34. The method of claim 28 further comprising the step of localizing the gallbladder via endoscopic ultrasound.

35. The method of claim 28 further comprising the step of removing gallstones.

36. The method of claim 28 further comprising the step of altering gallstones.

37. The method of claim 36 further comprising the step of removing the altered gallstones.

38. (canceled)

39. The method of claim 28 wherein the biliary disease is treated without removal of the gallbladder.

40. The method of claim 28 wherein the biliary disease is treated without removal of the cystic duct.

41. (canceled)

42. The method of claim 28 further comprising the step of forming a biological duct in situ from a patient's tissue.

43. The method of claim 28 further comprising the step of changing the cystic duct defunctionalizing device from a delivery configuration to a deployment configuration.

44. The method of claim 28 further comprising the step of changing the cystic duct defunctionalizing device from a delivery configuration to a final configuration.

45. The method of claim 28 further comprising the step of changing the cystic duct defunctionalizing device from a deployment configuration to a final configuration.

46. The method of claim 28 further comprising the step of reducing a cross-sectional profile of the cystic duct defunctionalizing device.

47. (canceled)

48. The method of claim 28 further comprising the step of defunctionalizing the cystic duct in situ.

49. The method of claim 48 wherein the step of defunctionalizing is achieved by delivering a substance into a space within the cystic duct.

50. The method of claim 49 wherein the delivered substance is selected from the group consisting of gel and foam.

51. The method of claim 49 further comprising the step of activating the delivered substance in situ.

52. The method of claim 49 further comprising delivering an amount of substance sufficient to fill, or substantially fill, the cystic duct lumen.

53. The method of claim 48 wherein the step of defunctionalizing is achieved by delivering a plug into a space within the cystic duct.

54. The method of claim 53 wherein the plug is configurable either internally or externally to seat within the lumen.

55. The method of claim 53 wherein the plug further comprises one or more thread profiles, ridges or steps about its exterior surface.

56. (canceled)

- 57. A kit for treating biliary disease comprising:
 - a. a device configurable to be positioned within a cystic duct; and optionally
 - b. a compound for delivery to a tissue.
- 58. (canceled)
- 59. (canceled)
- 60. (canceled)
- 61. (canceled)
- 62. (canceled)
- 63. (canceled)
- 64. (canceled)
- 65. (canceled)
- 66. A method of treating biliary disease comprising:
 - a. accessing a lumen associated with a gallbladder;
 - b. defunctionalizing a cystic duct.
- 67. (canceled)
- 68. (canceled)
- 69. (canceled)
- 70. The method of claim 69 wherein the substance is one or more of antibiotics, inflammatory agents, and anti-inflammatory agents.
- 71. The method of claim 66 further comprising the step of preventing bile from entering the gallbladder lumen.
- 72. (canceled)
- 73. The method of claim 66 further comprising the step of accessing the gallbladder via the gastrointestinal tract.
- 74. The method of claim 73 wherein the step of accessing is performed in the gastrointestinal tract at a duodenum.
- 75. The method of claim 73 wherein the step of defunctionalizing the cystic duct further comprises one or more of sclerosing, necrotizing or ablating tissue.

- 76. The method of claim 75 wherein an ablation technique is selected from the group comprising cryoablation, thermal ablation, chemical ablation, radio frequency ablation, ultrasound ablation, and microwave ablation.
- 77. The method of claim 73 further comprising the step of delivering a fluid with an angular orientation.
- 78. The method of claim 73 further comprising the step of delivering a fluid with at least one of a 360 degree radial pattern, a sharp stream, and a cone shape.
- 79. The method of claim 73 further comprising the step of delivering a fluid with a device comprising an articulating member.
- 80. The method of claim 73 wherein the step of defunctionalizing the cystic duct further comprises applying a vacuum to a lumen of the cystic duct or the gallbladder.
- 81. The method of claim 80 further comprising the step of applying all adhesive to the lumen of the cystic duct.
- 82. (canceled)
- 83. A device for treating biliary disease comprising a plug adapted and configurable to be positioned within a lumen of a cystic duct of a patient having a proximal end and a distal end and is configurable either internally or externally to seat within the lumen after deployment.
- 84. The device of claim 83 wherein the external configuration is one or more of threads, ridges and steps.
- 85. (canceled)
- 86. (canceled)
- 87. The device of claim 83 wherein the plug is positioned within or proximal to a cystic duct.

* * * * *