



US 20070049962A1

(19) **United States**

(12) **Patent Application Publication**
Marino et al.

(10) **Pub. No.: US 2007/0049962 A1**

(43) **Pub. Date: Mar. 1, 2007**

(54) **NERVE SURVEILLANCE CANNULAE SYSTEMS**

(75) Inventors: **James F. Marino**, La Jolla, CA (US);
Dan K. Ahigren, San Diego, CA (US)

Correspondence Address:
JONATHAN SPANGLER
NU VASIVE, INC.
4545 TOWNE CENTRE COURT
SAN DIEGO, CA 92121 (US)

(73) Assignee: **NuVasive, Inc.**, San Diego, CA

(21) Appl. No.: **11/489,020**

(22) Filed: **Jul. 18, 2006**

Related U.S. Application Data

(62) Division of application No. 10/431,619, filed on May 7, 2003, now Pat. No. 7,079,883, which is a division of application No. 09/325,998, filed on Jun. 4, 1999, now Pat. No. 6,564,078.

(60) Provisional application No. 60/120,663, filed on Feb. 19, 1999. Provisional application No. 60/113,651, filed on Dec. 23, 1998. Provisional application No. 60/123,268, filed on Mar. 8, 1999.

Publication Classification

(51) **Int. Cl.**
A61M 29/00 (2006.01)
(52) **U.S. Cl.** **606/198**

(57) **ABSTRACT**

An expandable tip cannula system, comprising: a hollow cannula shaft having a proximal end and a distal end; and an expandable tip mounted at the distal end of the hollow cannula shaft, the expandable tip comprising a plurality of generally-triangular shaped petals held together in a radially-inwardly tapered arrangement between adjacent petals, each petal comprising a nerve sensing electrode disposed therein.

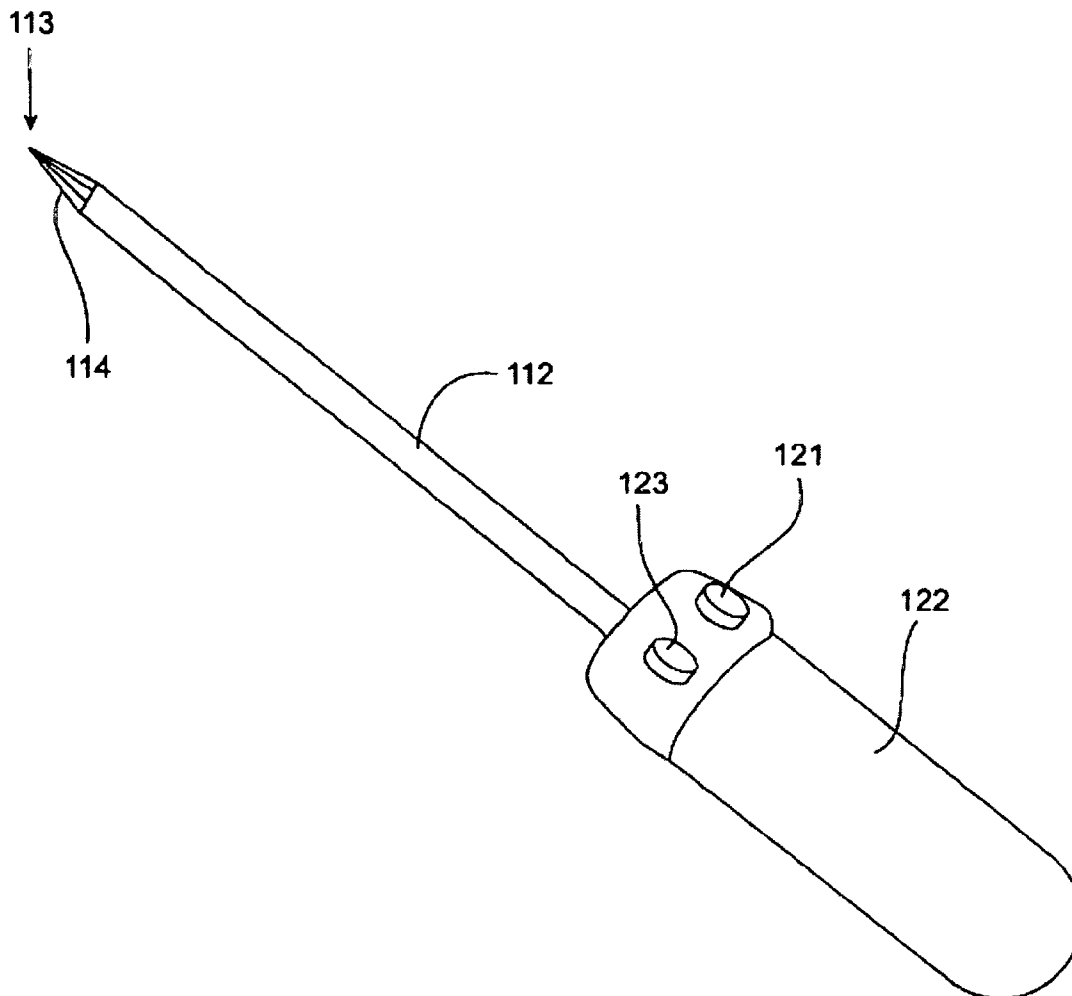

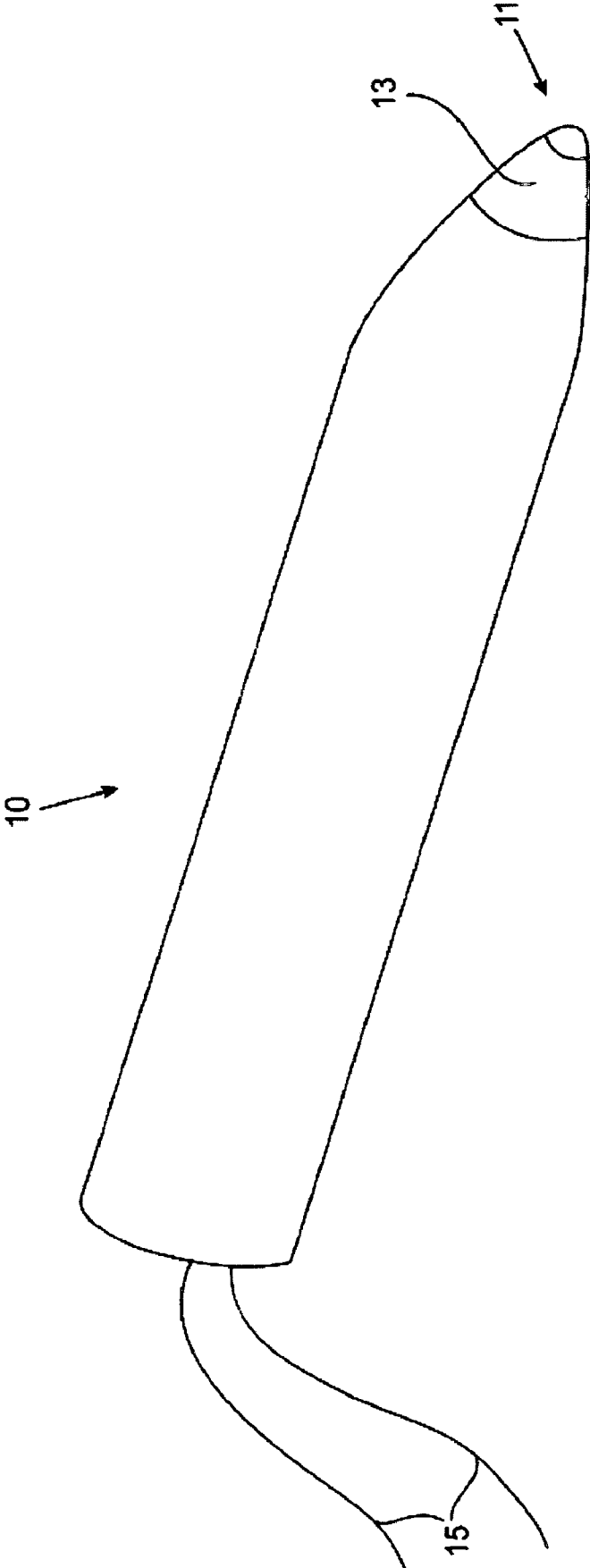

FIG. 1

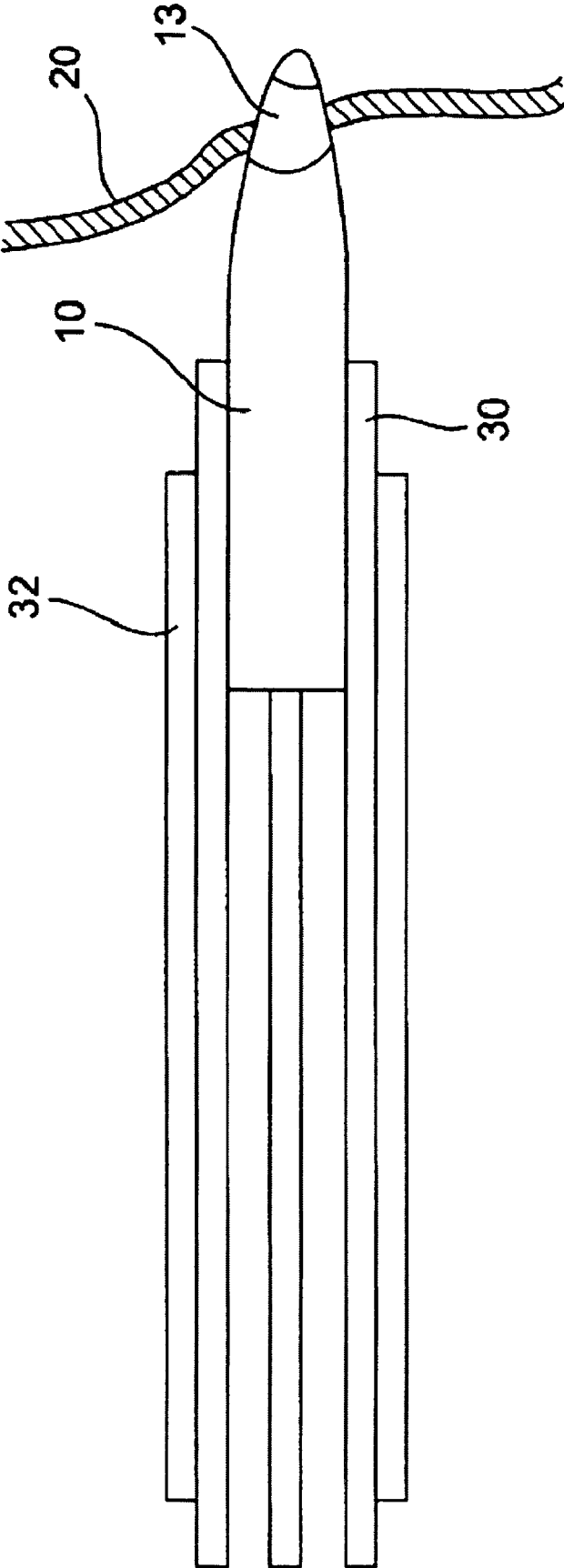

FIG. 2

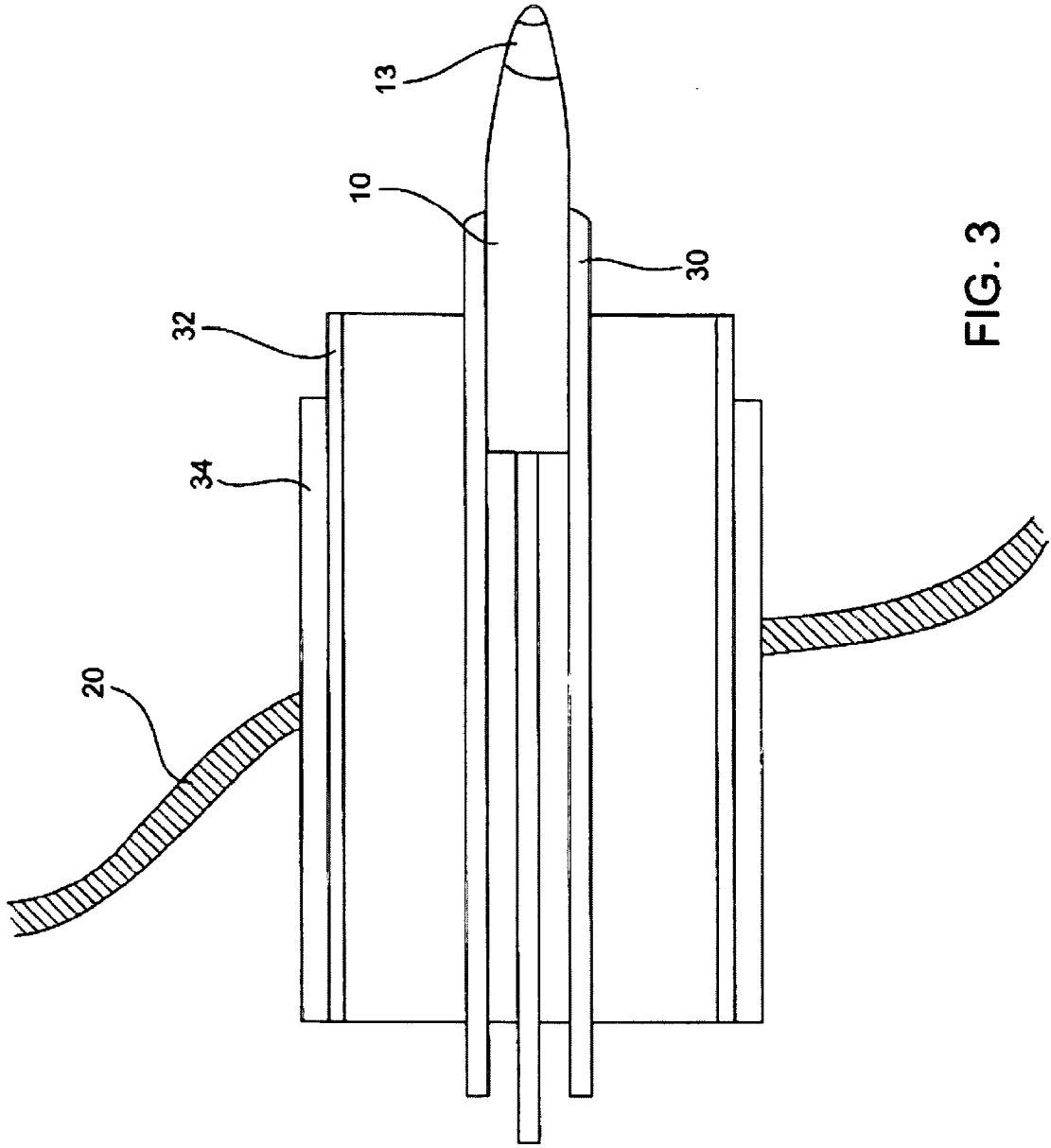
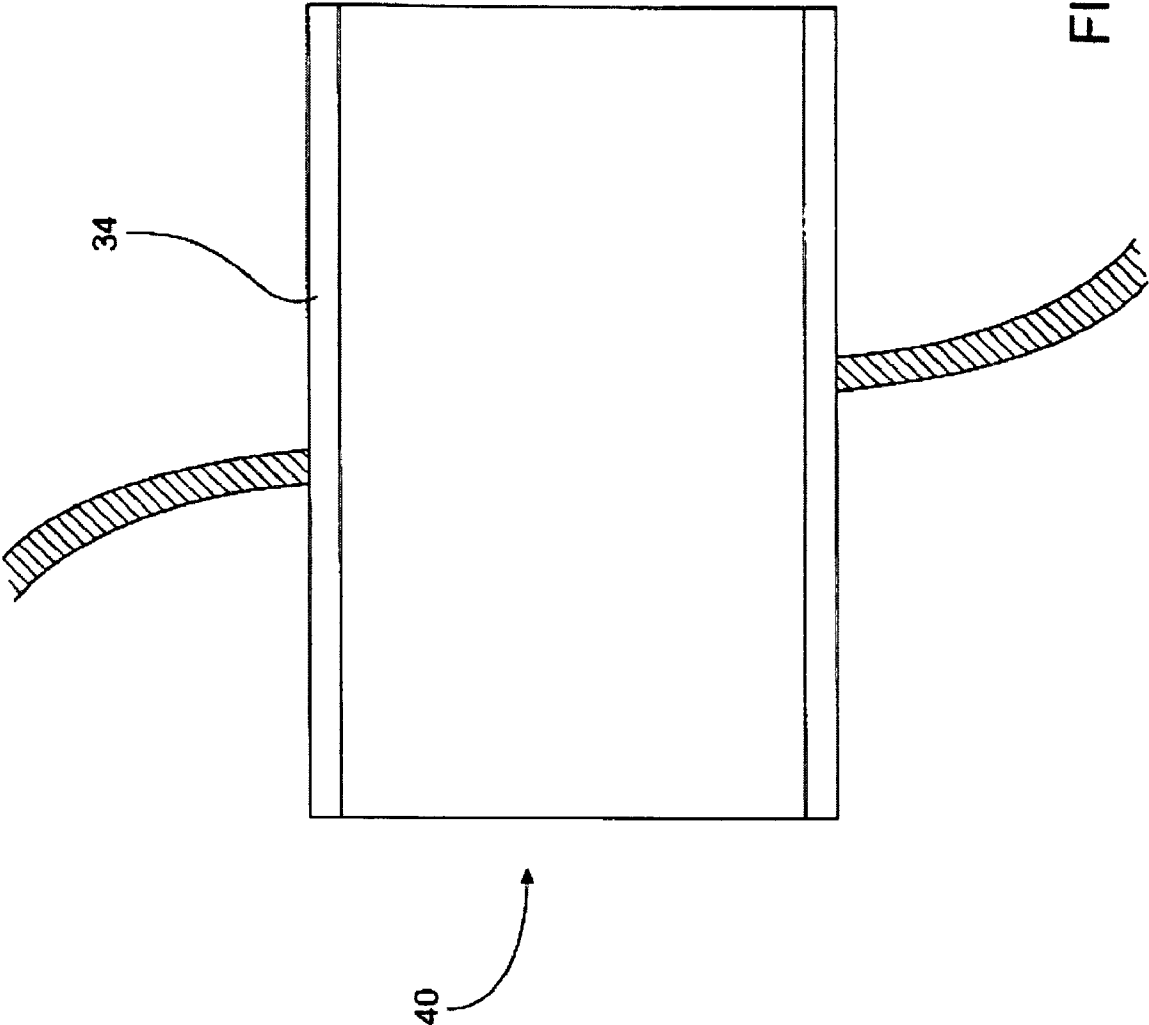

FIG. 3



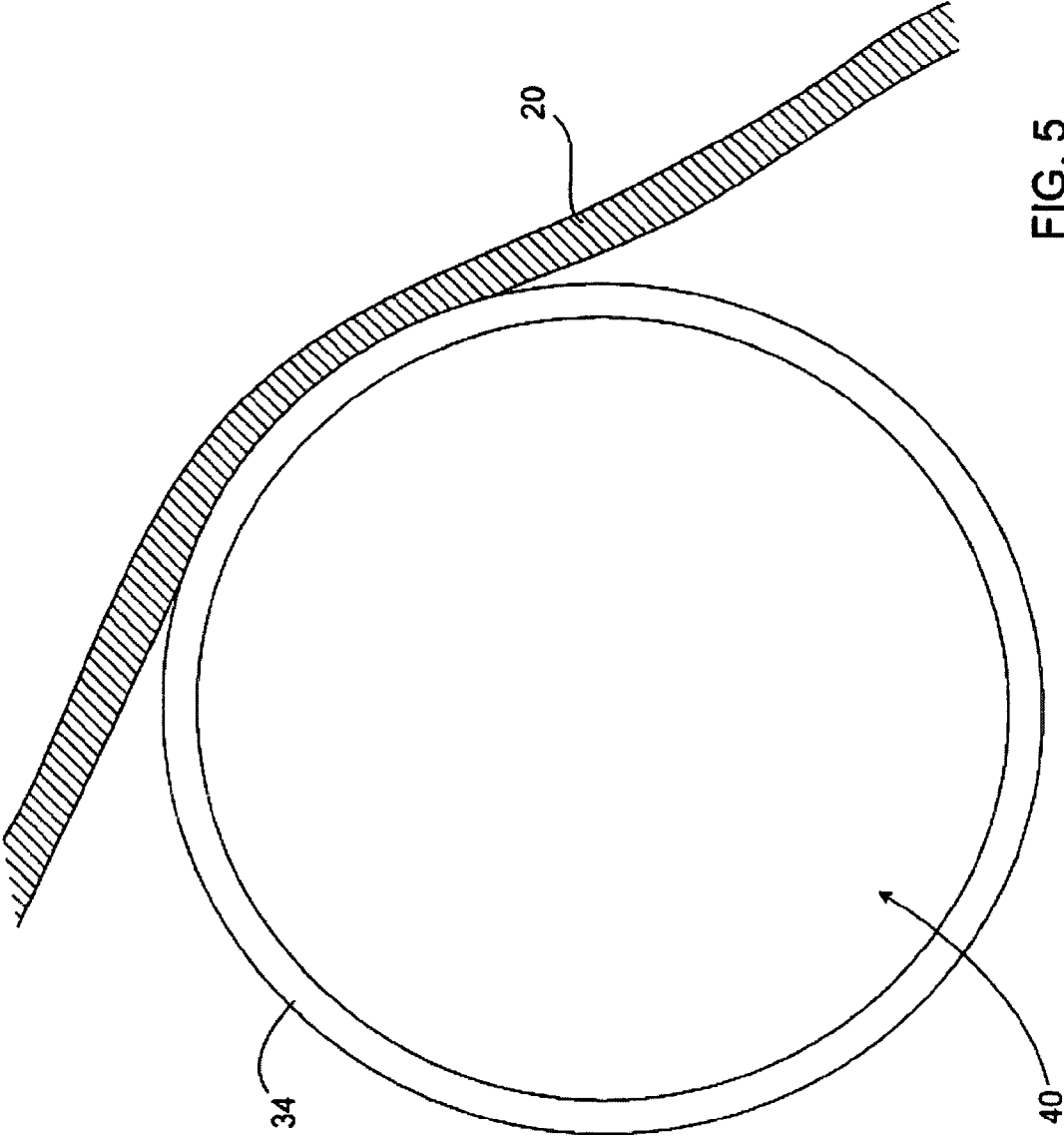

FIG. 5

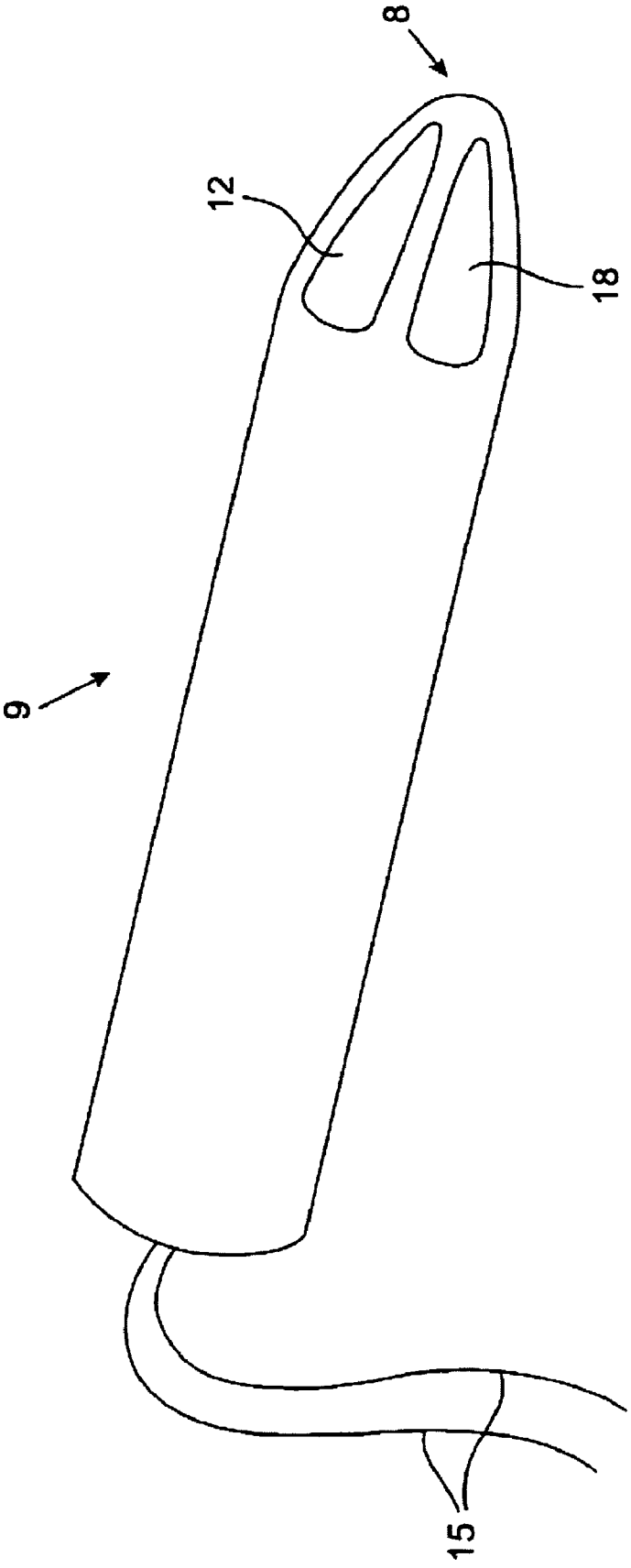

FIG. 6

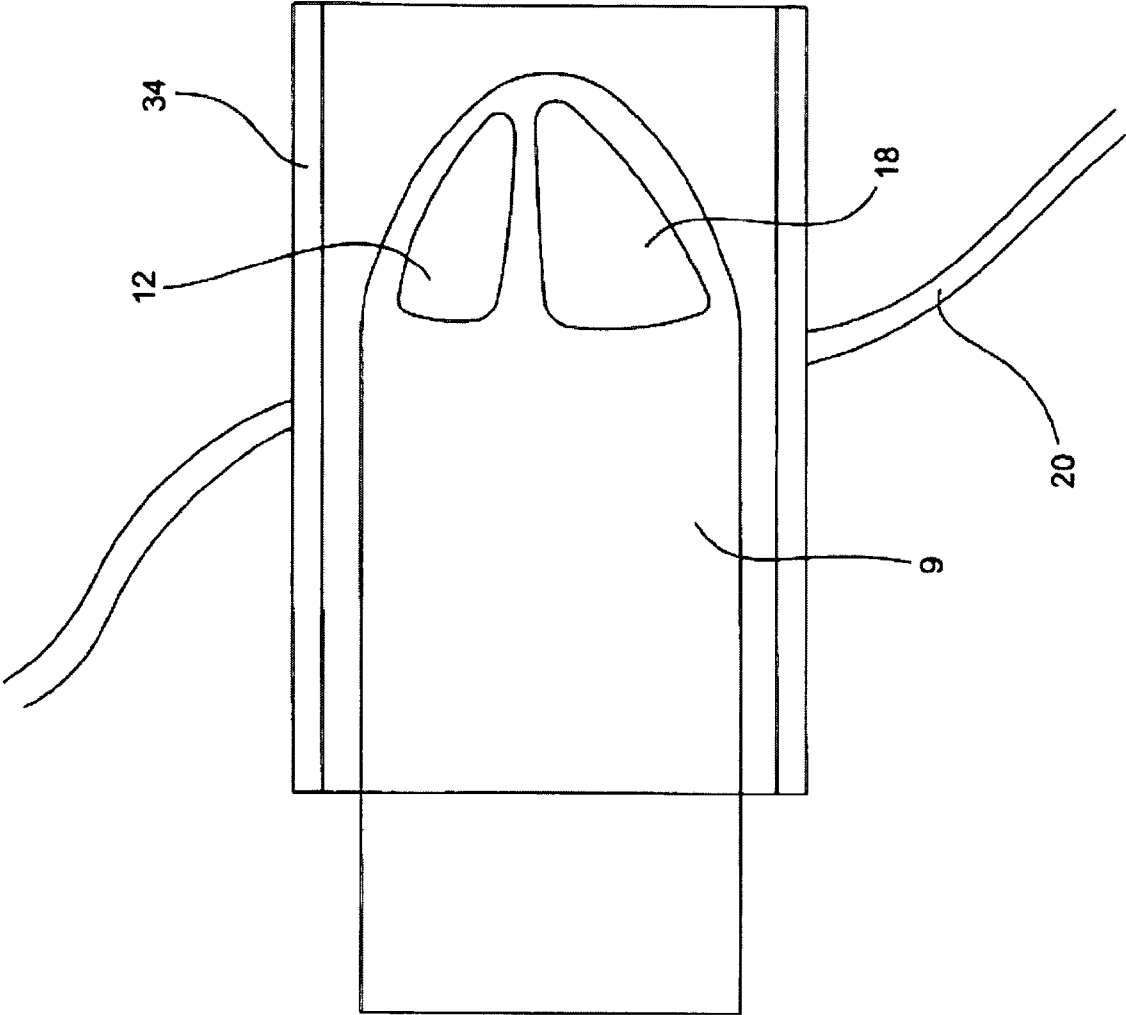

FIG. 7

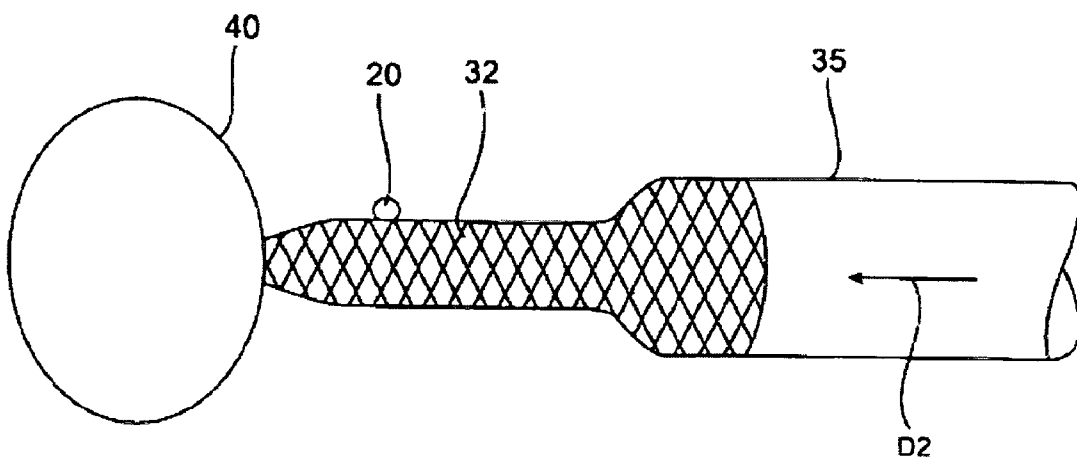

FIG. 9A

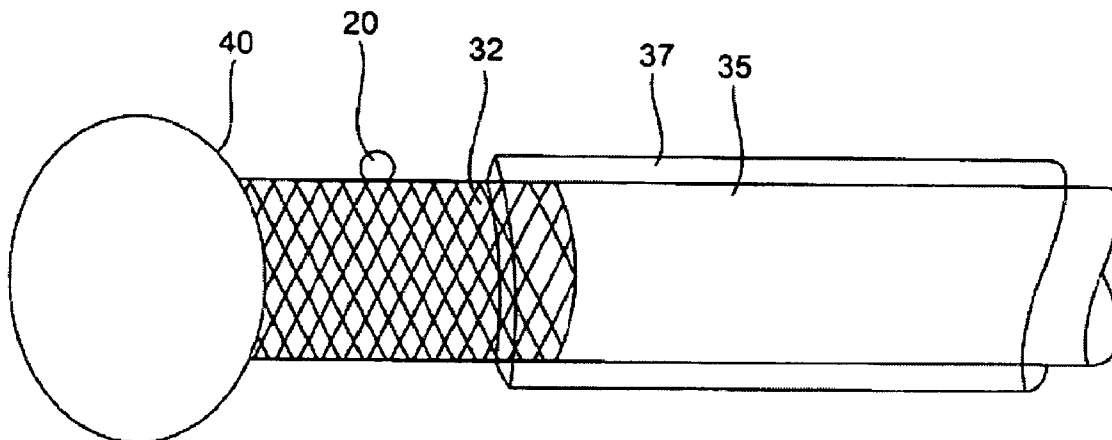

FIG. 9B

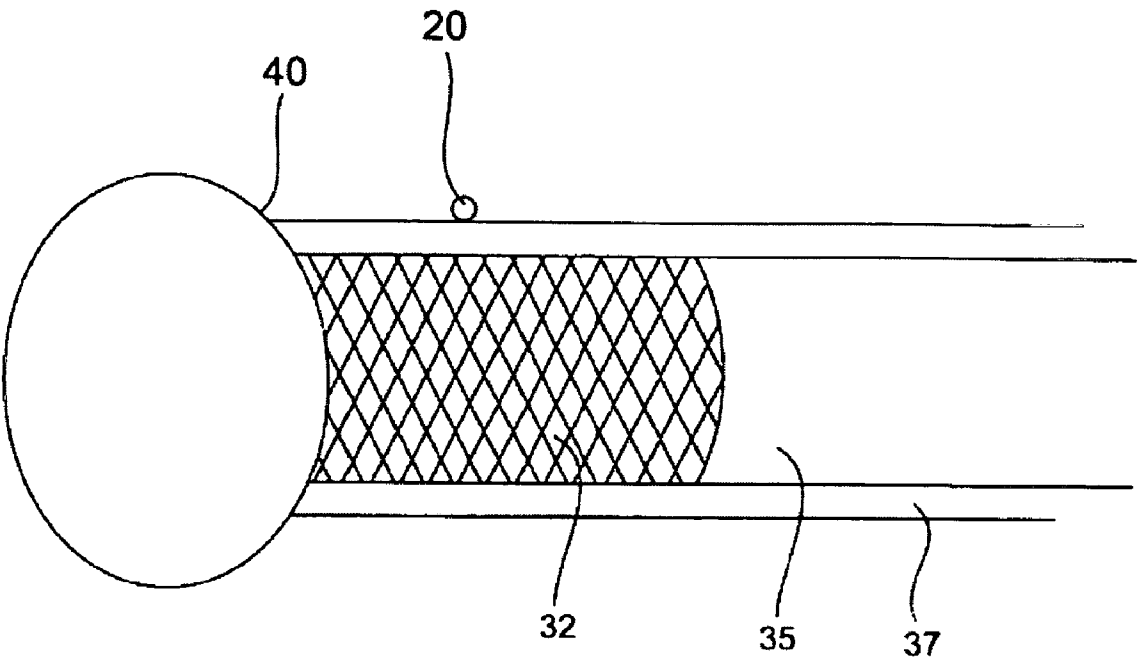

FIG. 9C

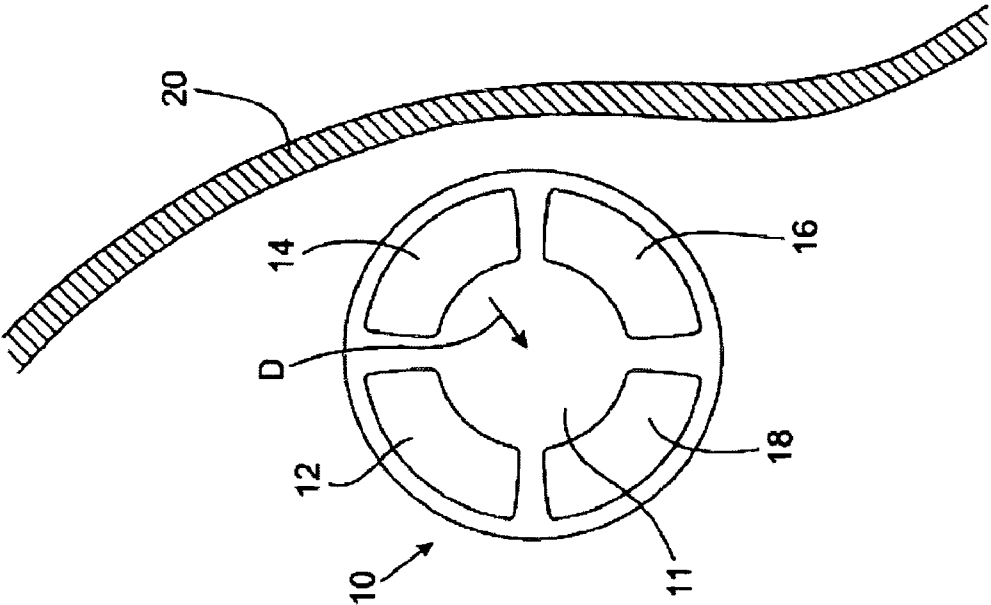

FIG. 10

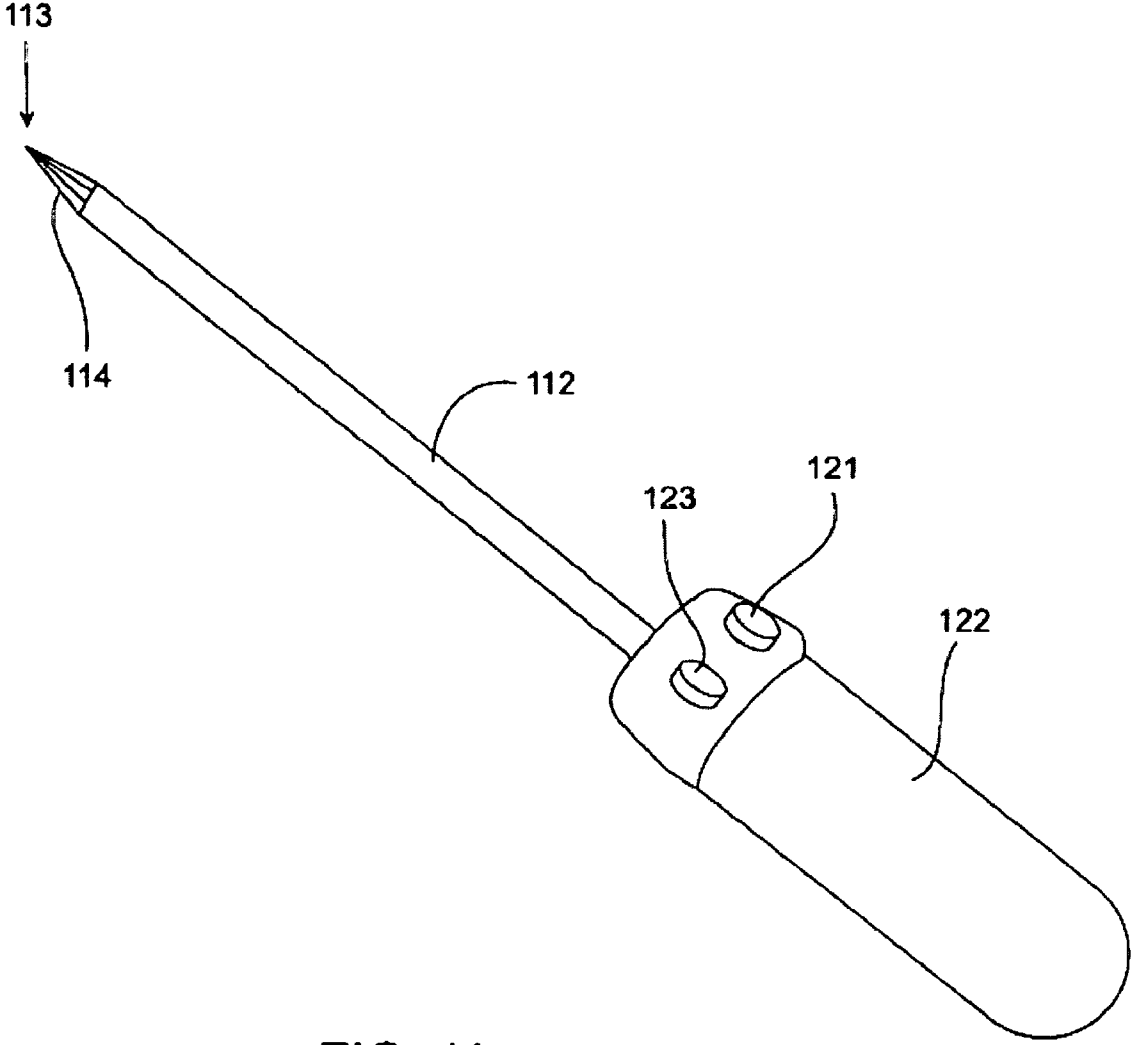

FIG. 11

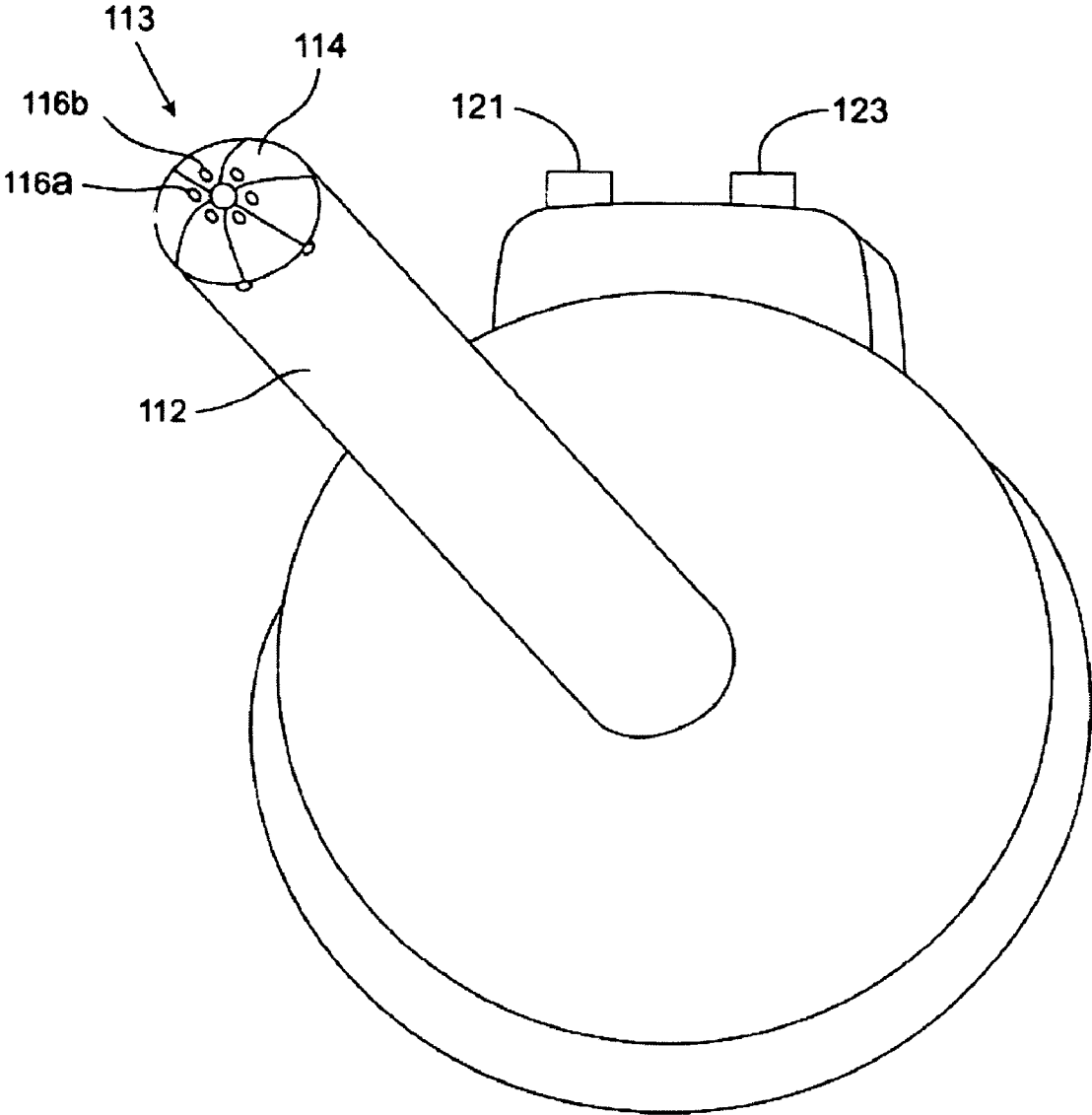

FIG. 12

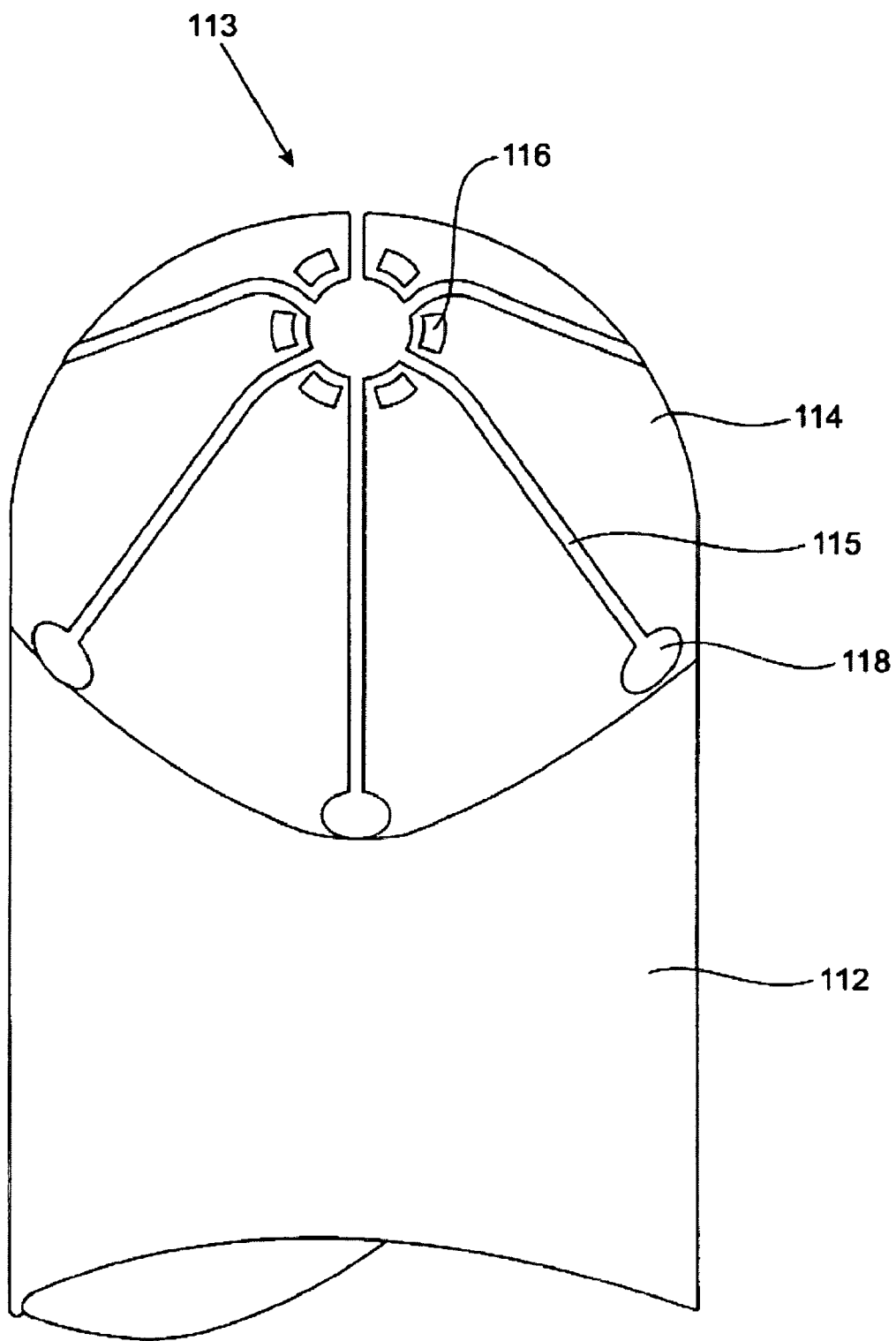

FIG. 13

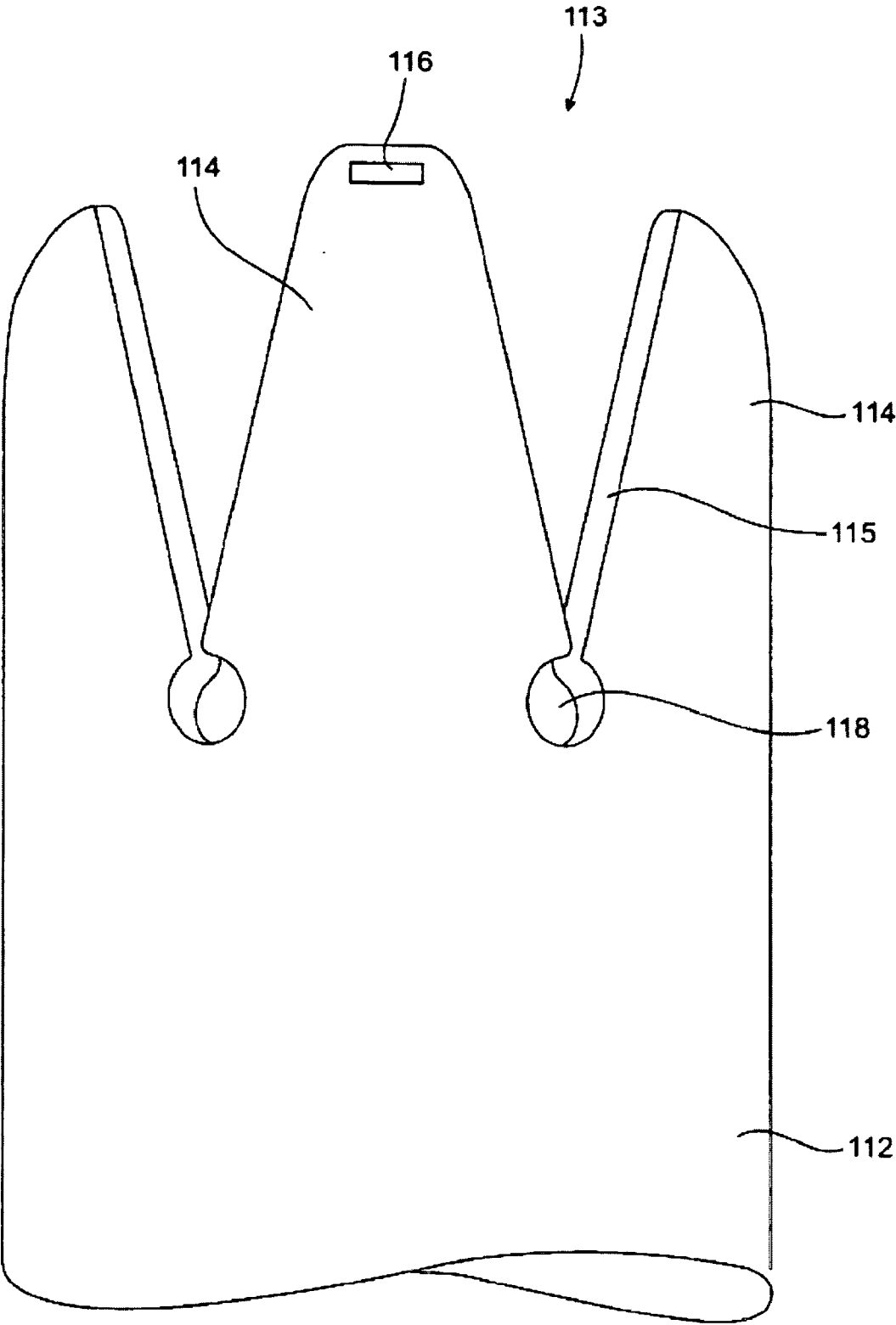

FIG. 14

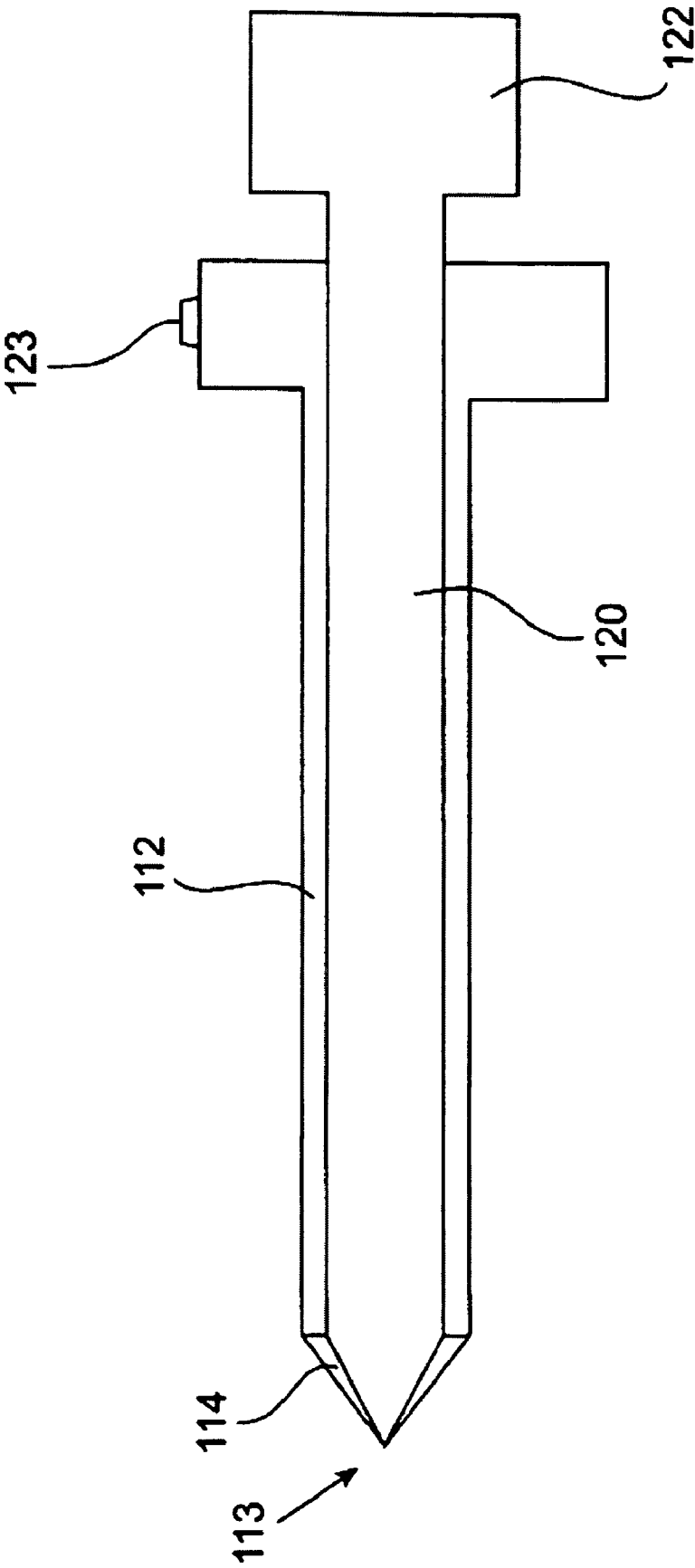

FIG. 15

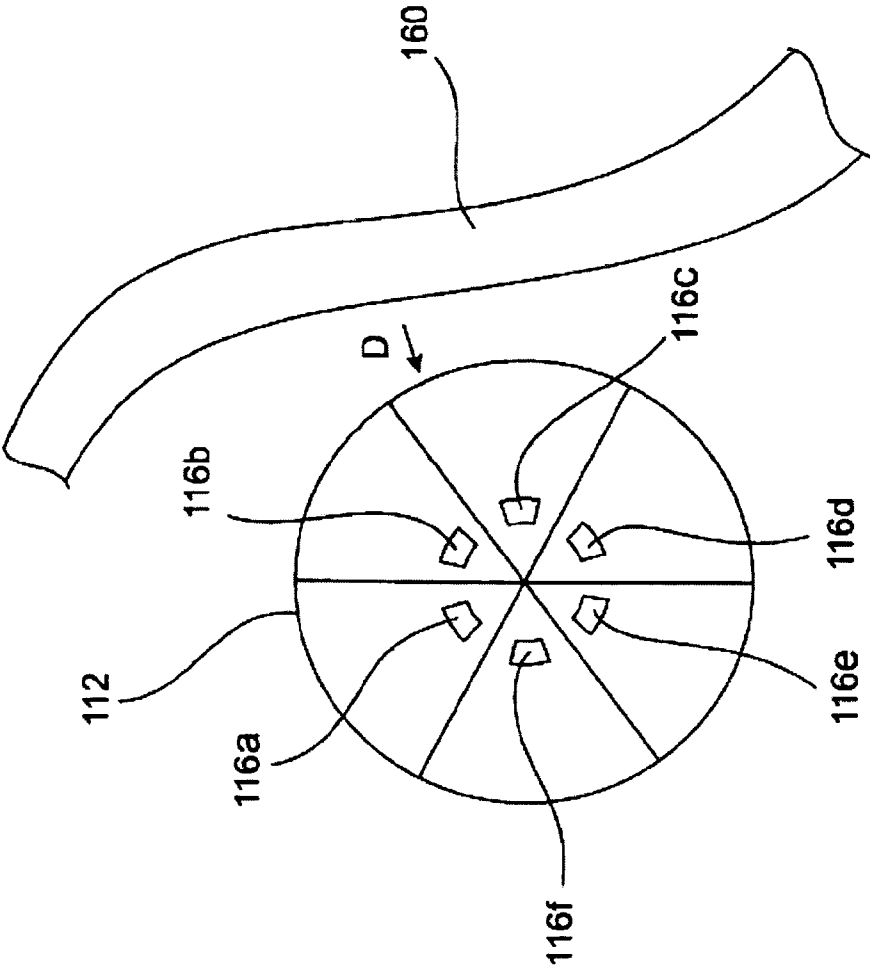

FIG. 16

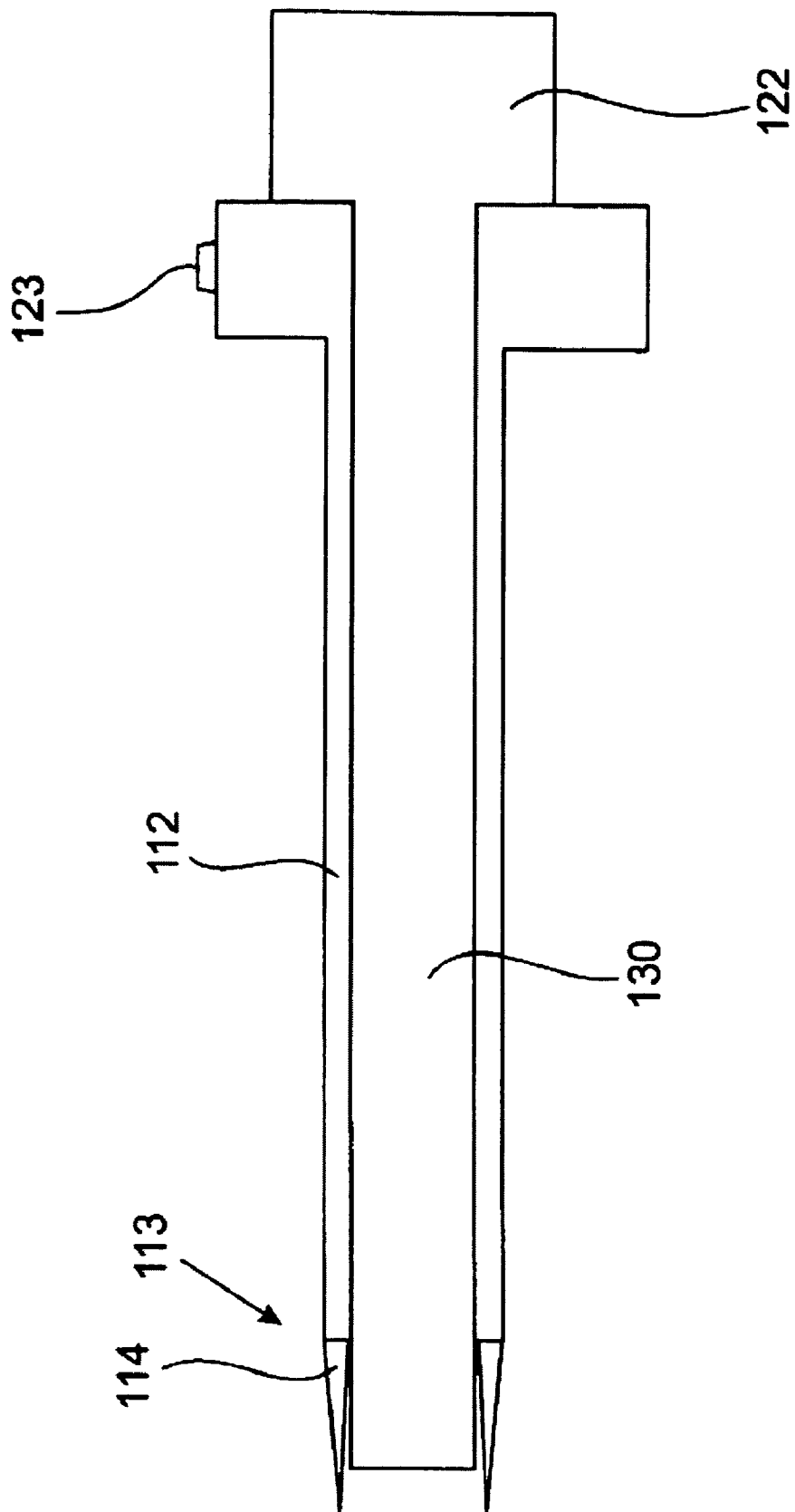

FIG. 17

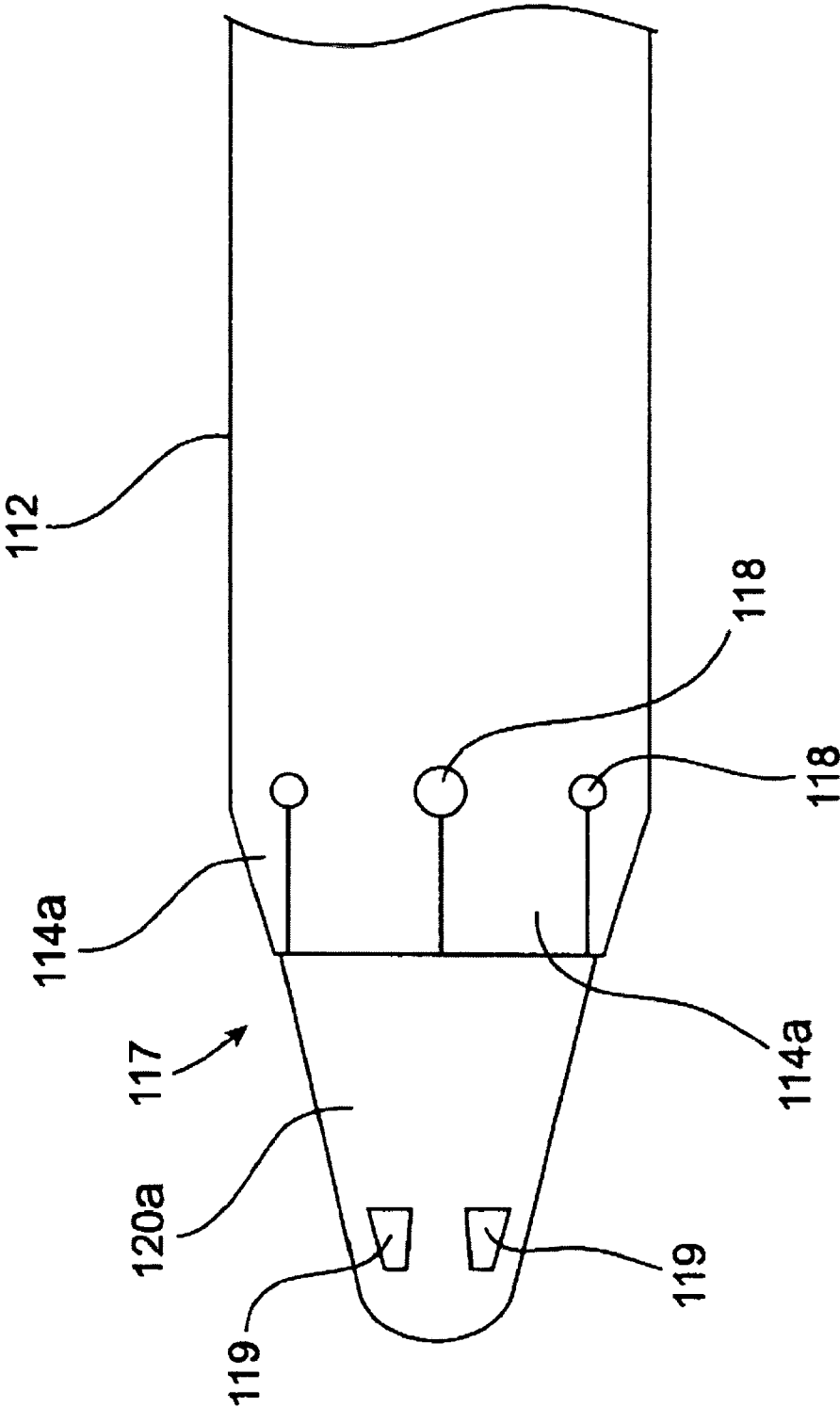

FIG. 18

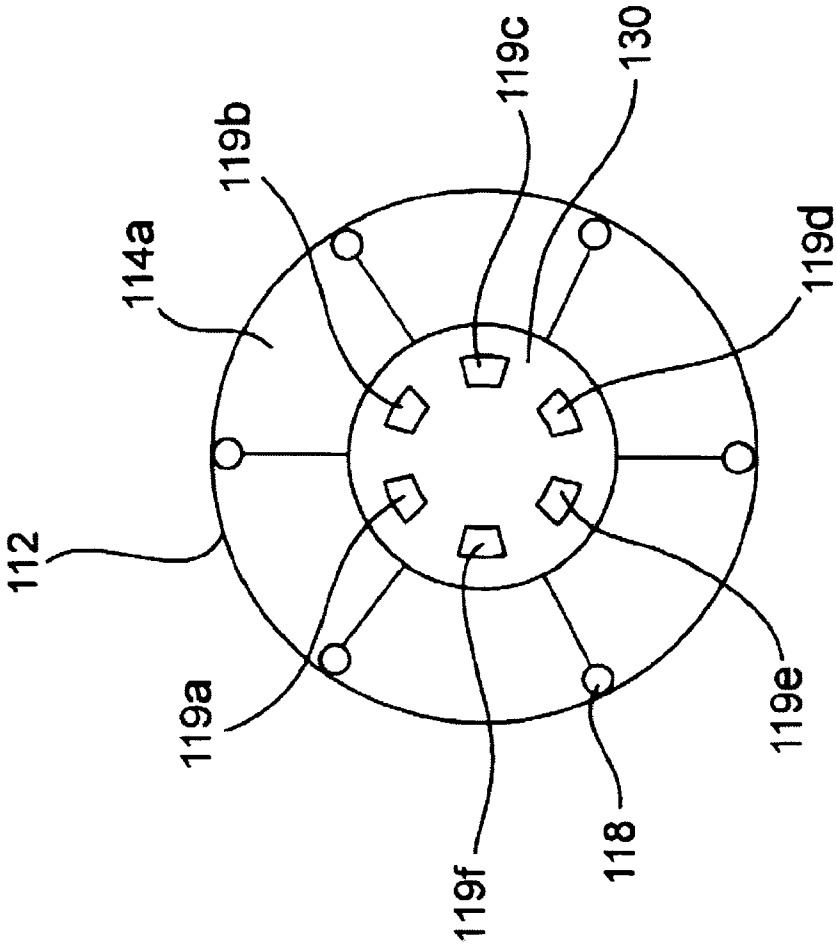

FIG. 19

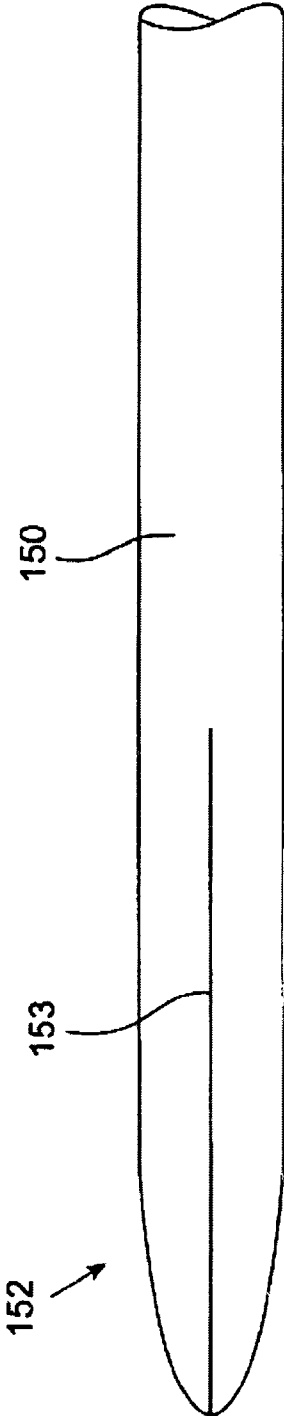

FIG. 20

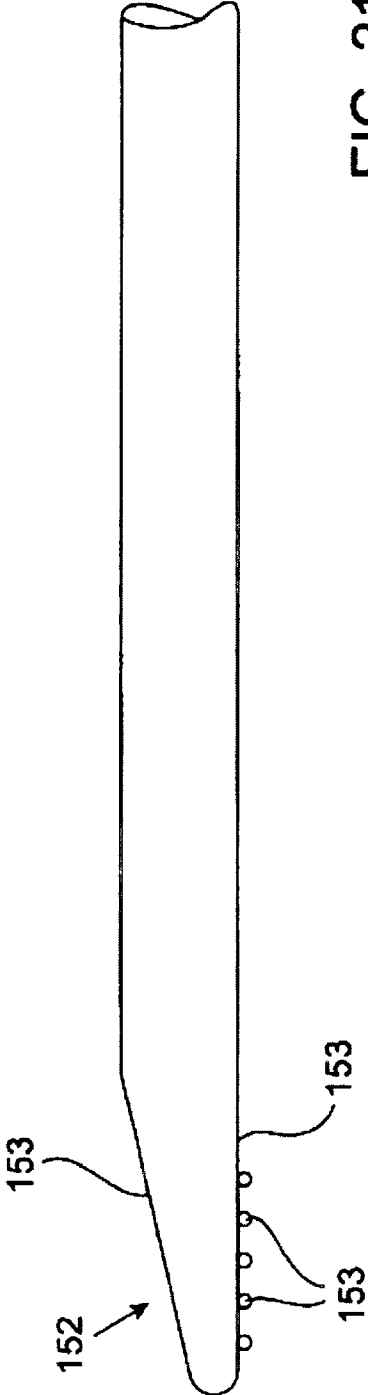

FIG. 21

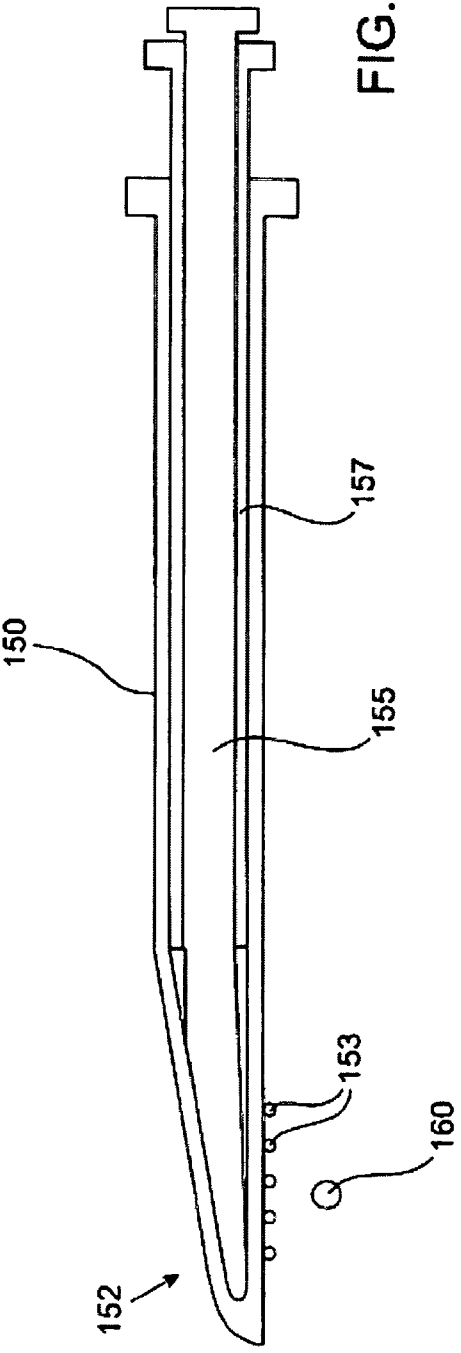

FIG. 22

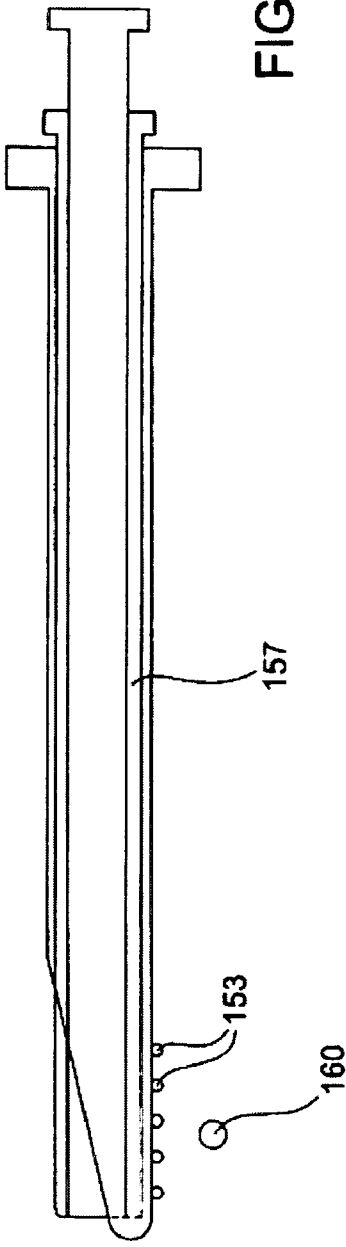

FIG. 23

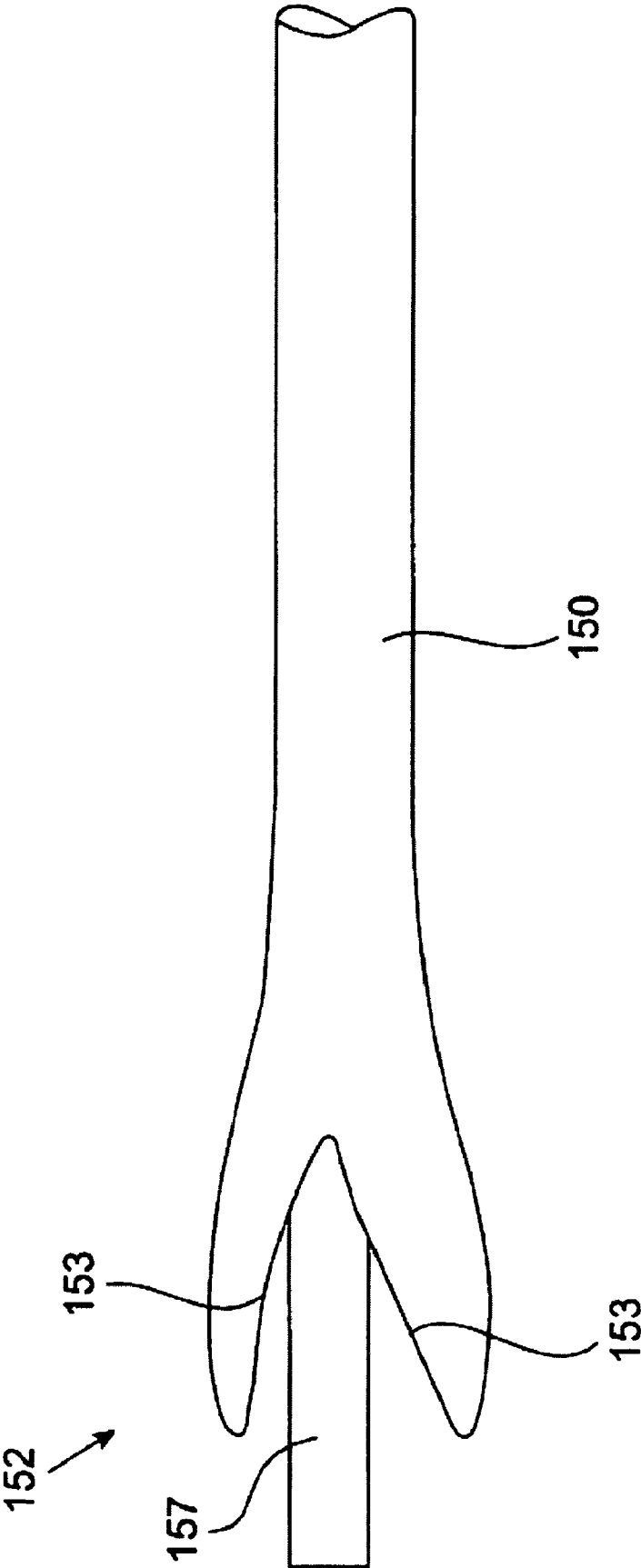
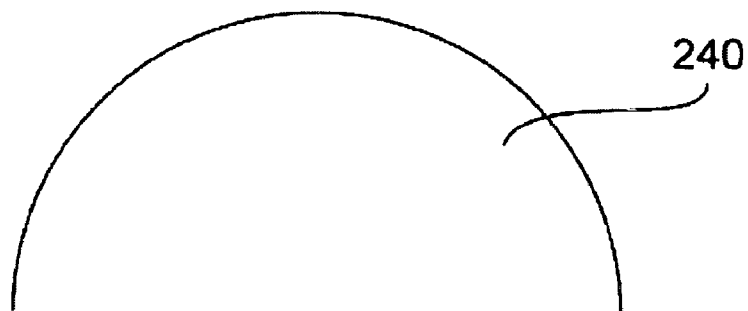
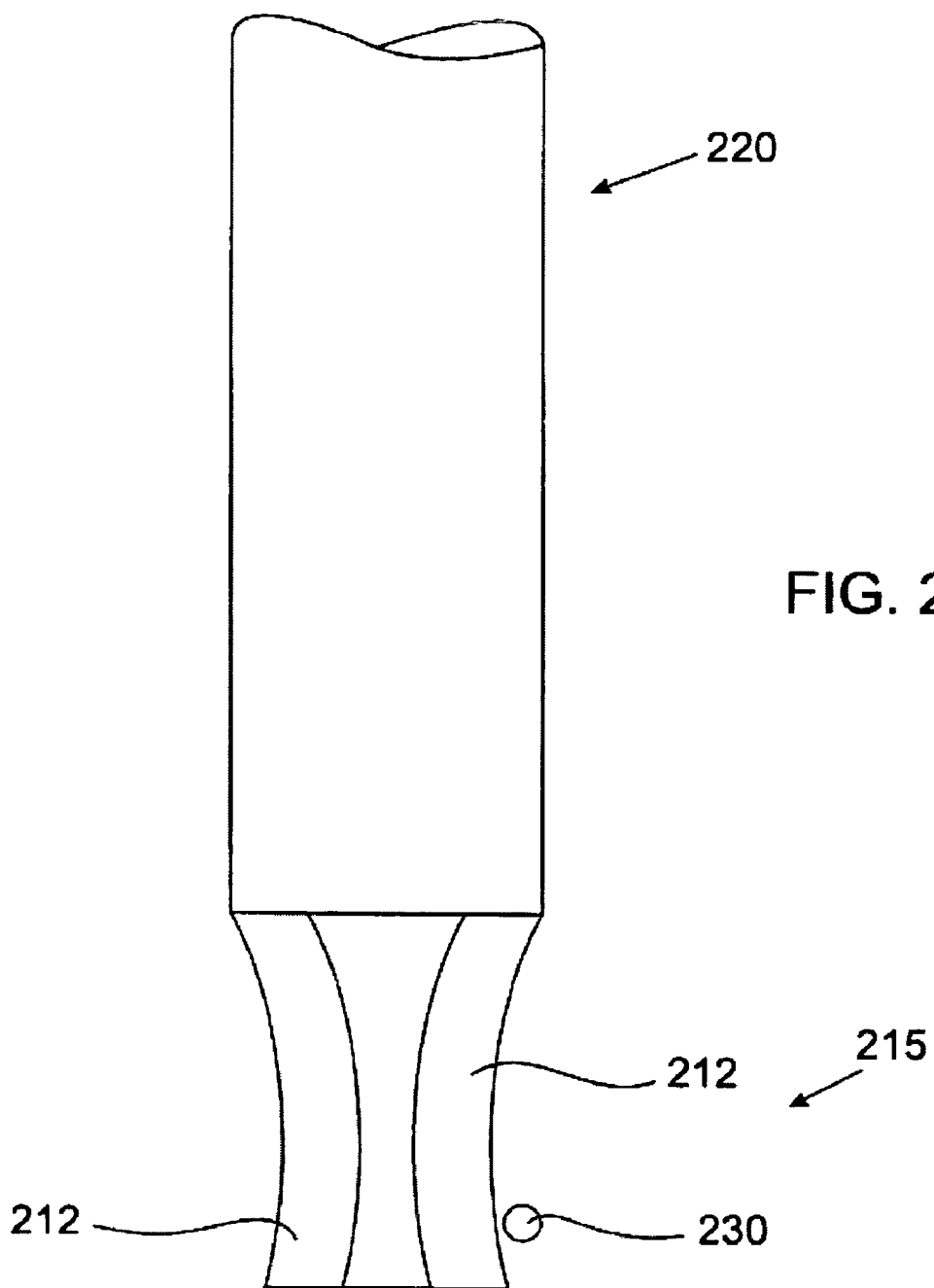

FIG. 24



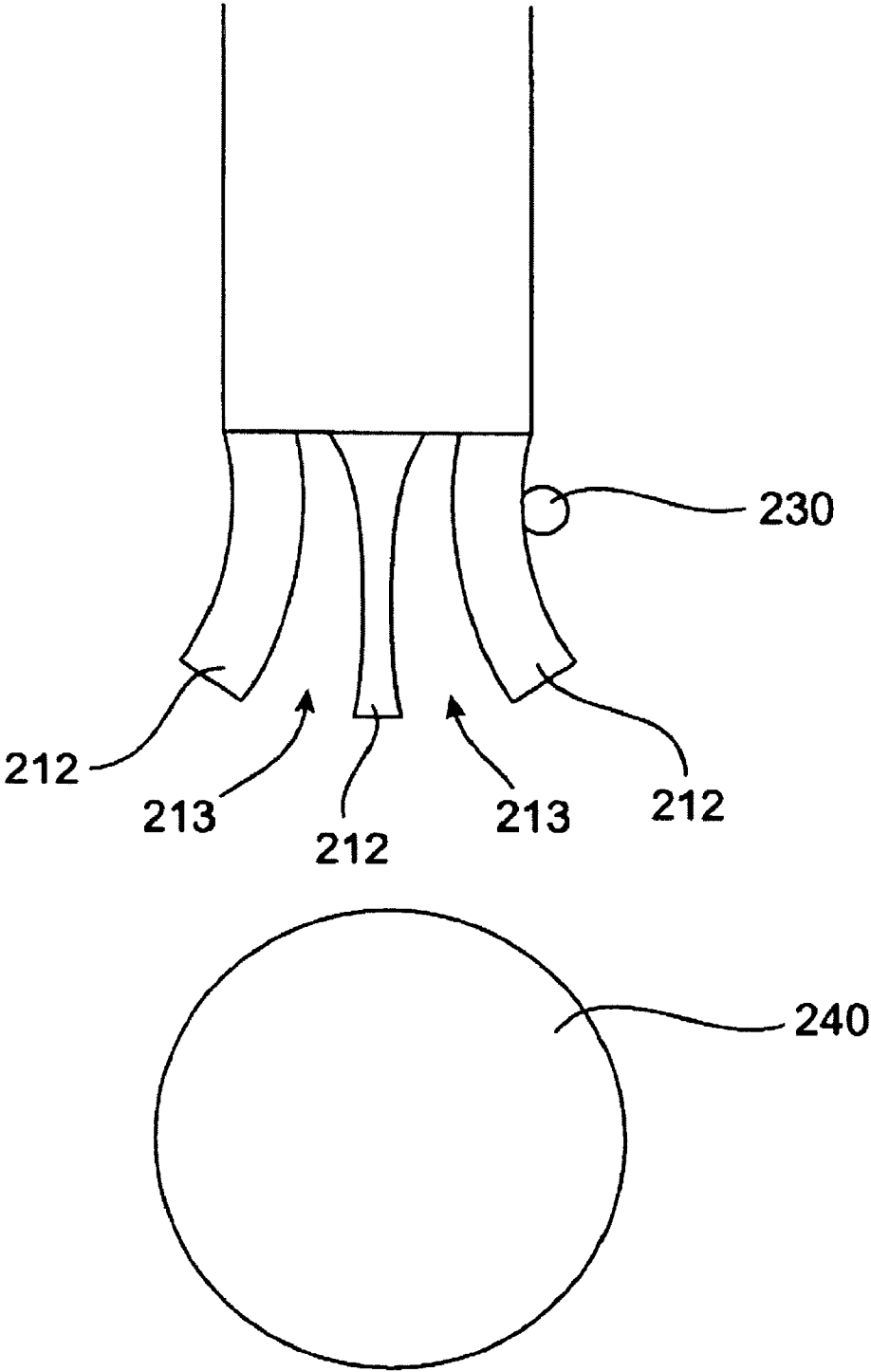

FIG. 26

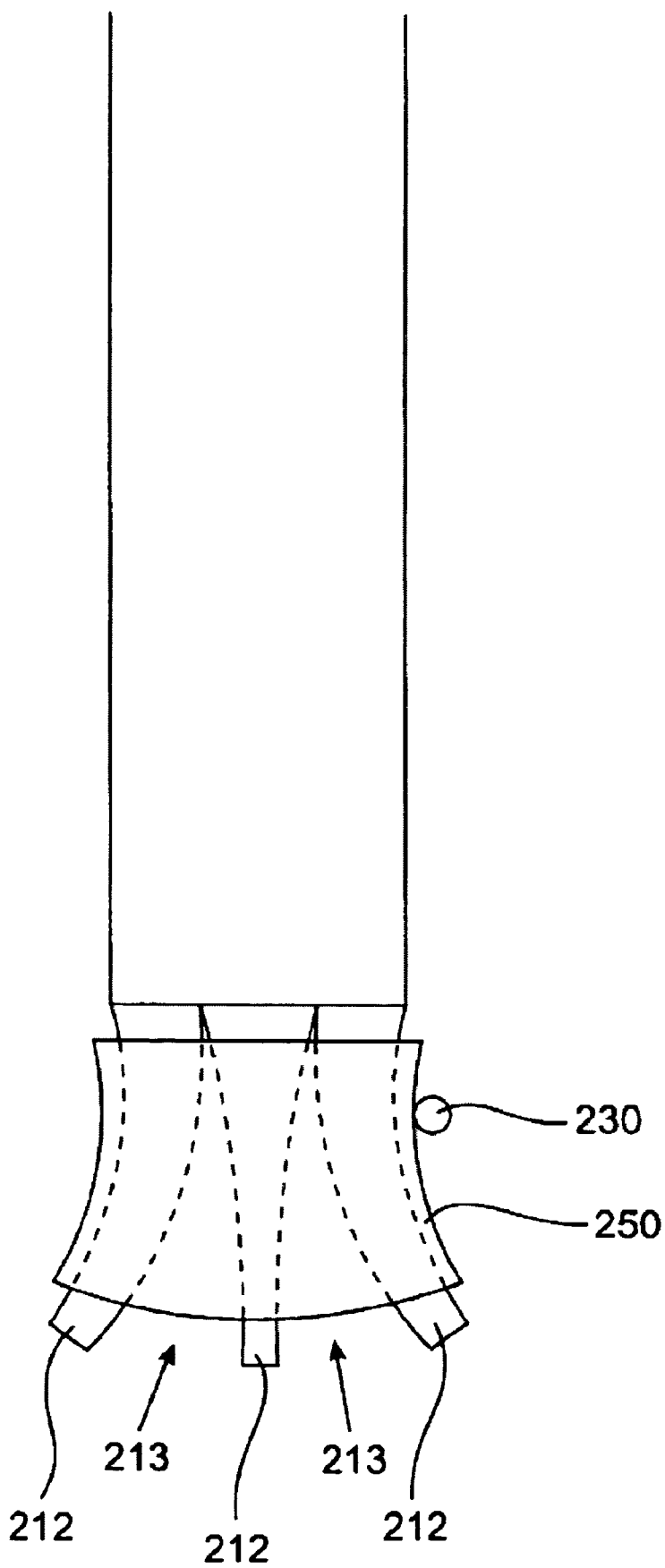

FIG. 27

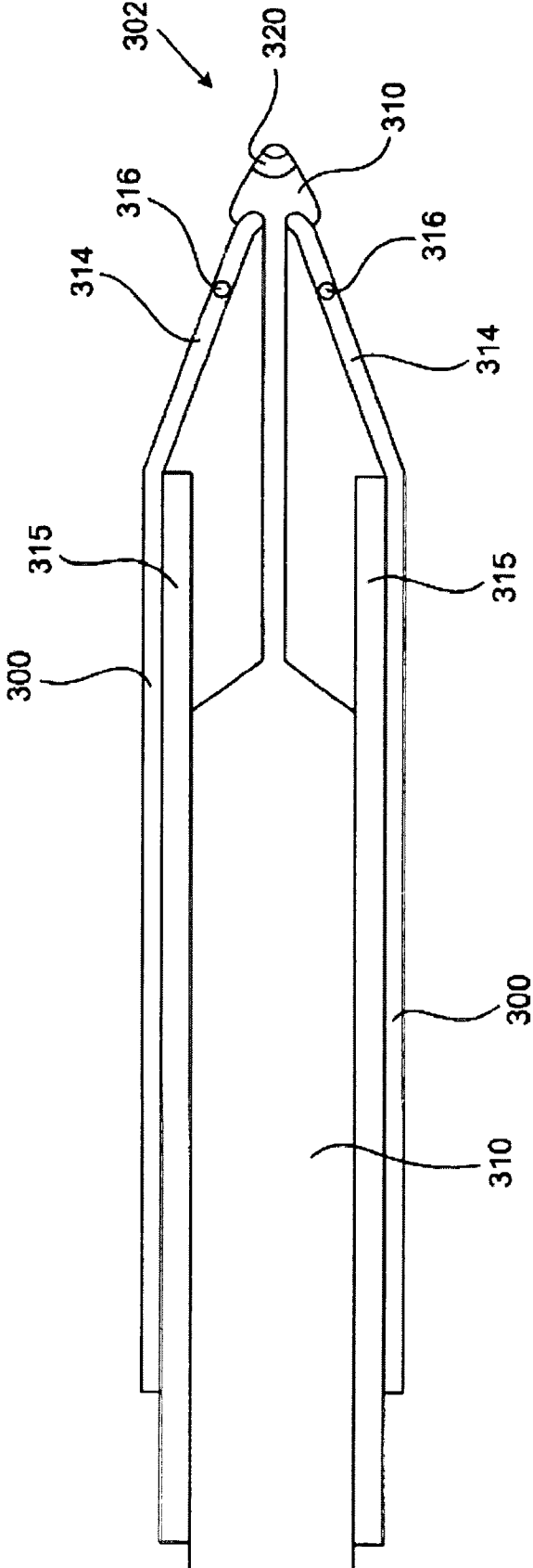

FIG. 28

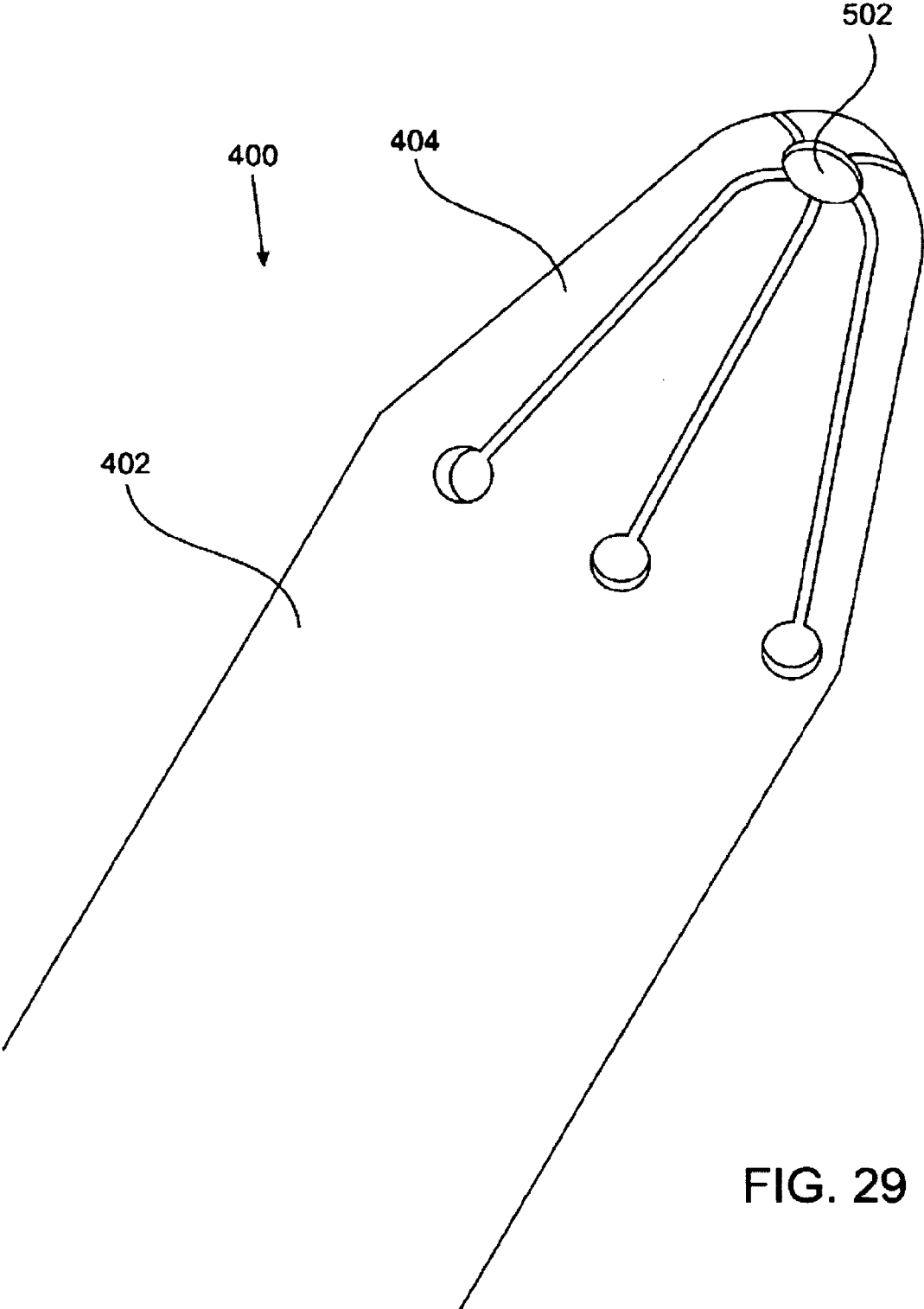

FIG. 29

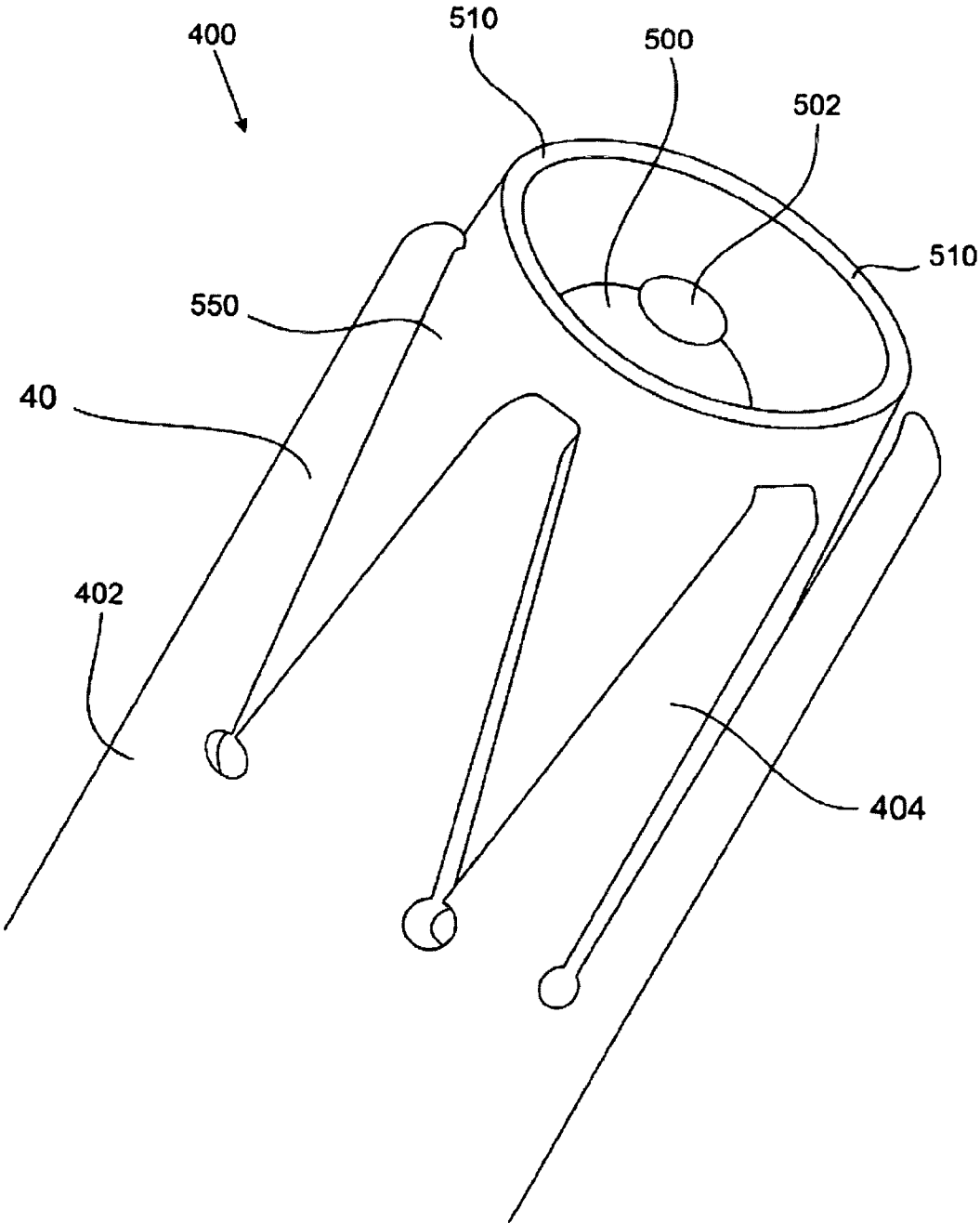

FIG. 30

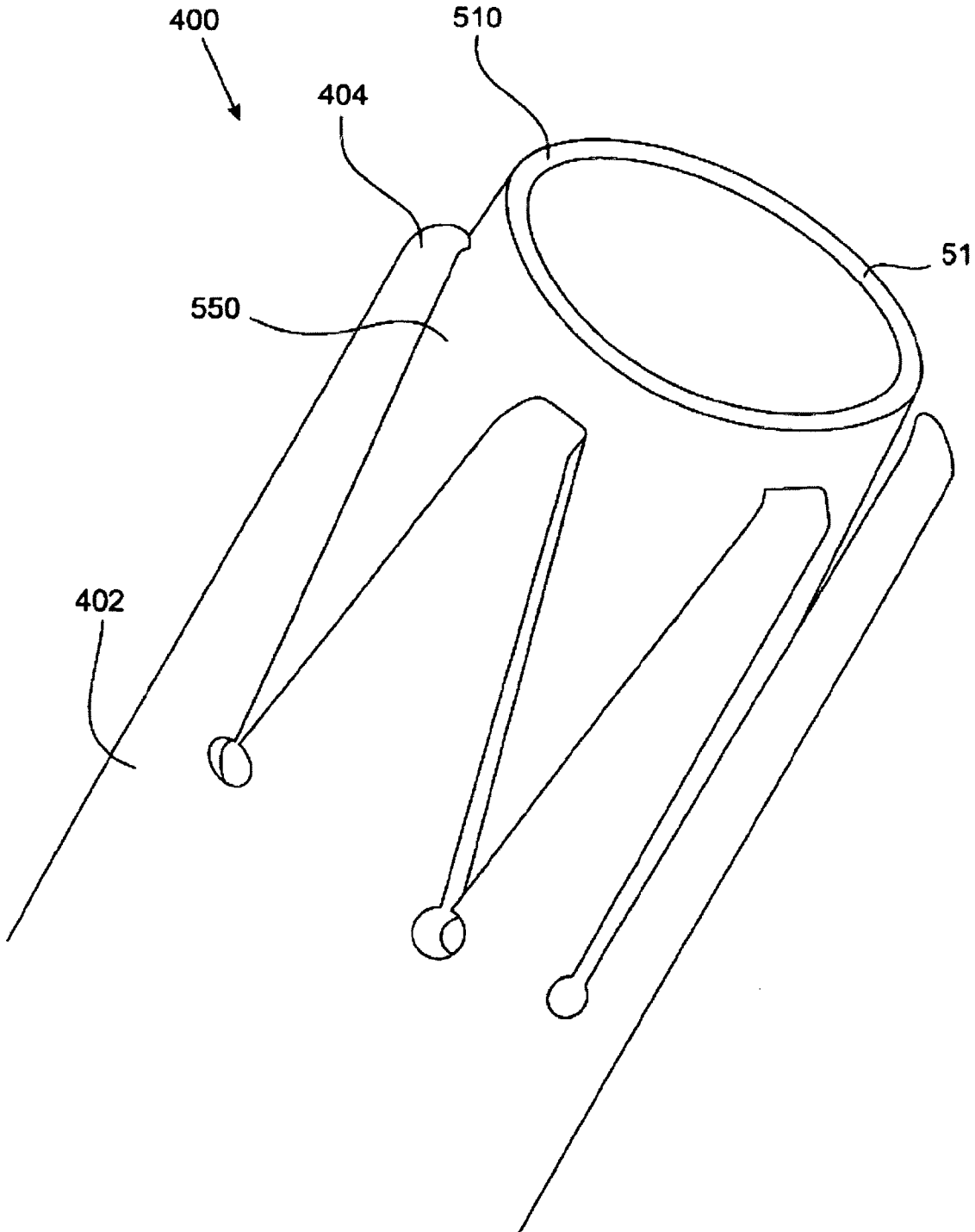

FIG. 31

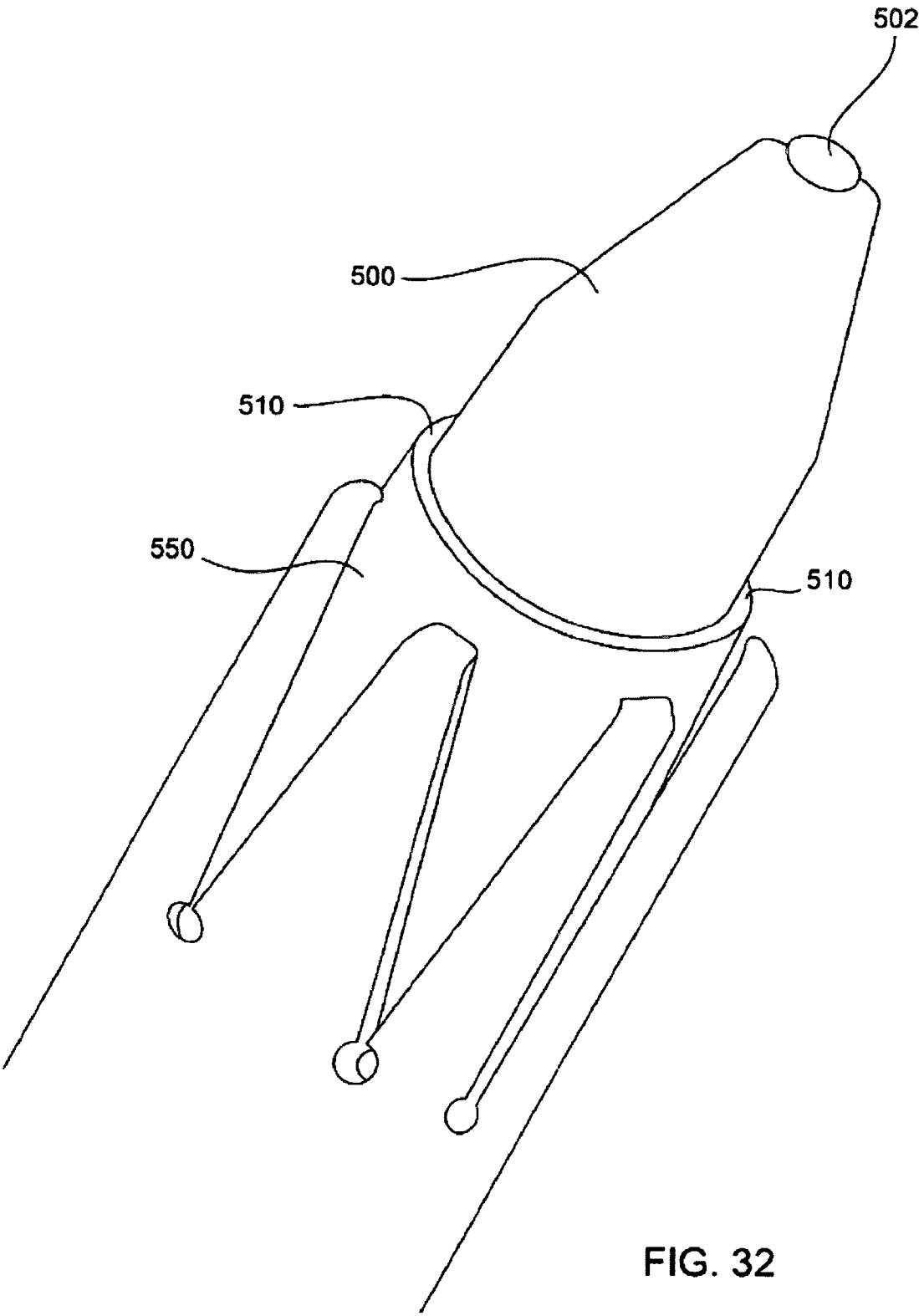

FIG. 32

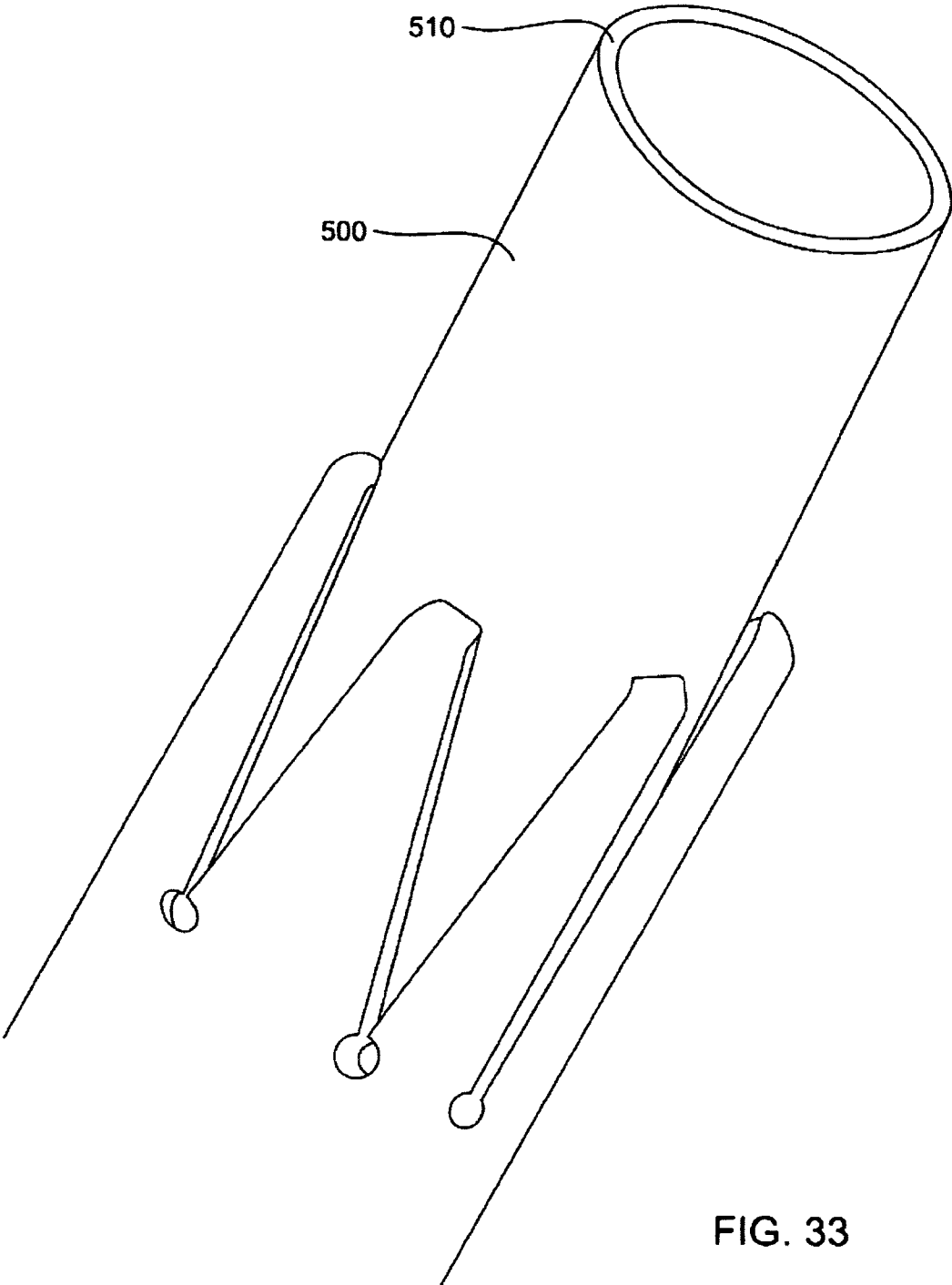

FIG. 33

NERVE SURVEILLANCE CANNULAE SYSTEMS

CROSS-REFERENCES TO RELATED APPLICATIONS

[0001] The present application is a division of commonly owned and co-pending U.S. patent application Ser. No. 10/431,619, filed on May 7, 2003, which is a divisional application of commonly owned and co-pending U.S. patent application Ser. No. 09/325,998, filed on Jun. 4, 1999 and issued as U.S. Pat. No. 6,564,078, the complete disclosure of which is hereby incorporated by reference in its entirety for all purposes. Additionally, the present application claims benefit under 35 U.S.C. §119(e) from U.S. Provisional Patent Applications Serial No. 60/113,651 filed Dec. 23, 1998; U.S. Provisional Patent Application Serial No. 60/120,663 filed Feb. 12, 1999; and U.S. Provisional Patent Application Serial No. 60/123,268 filed Mar. 8, 1999; the complete disclosures of which are hereby incorporated herein by reference in their entirety for all purposes.

TECHNICAL FIELD

[0002] The present invention relates to nerve surveillance systems and to cannulae systems for use in minimally invasive spinal surgery.

BACKGROUND OF THE INVENTION

[0003] A significant danger of performing intervertebral operations or accessing an intervertebral space during spine surgery is that of inadvertently contacting or damaging the para-spinal nerves, including the exiting nerve roots, traversing nerves and the nerves of the cauda equina. The exact location of these para-spinal nerves can not be determined prior to the commencement of surgery. Moreover, intervertebral spaces in the spine have other sensitive nerves disposed at locations which are not entirely predictable prior to insertion of the surgical tool into the intervertebral area. Accordingly, the danger of pinching or damaging spinal nerves when accessing an intervertebral space has proven to be quite limiting to the methods and devices used during minimally invasive spinal surgery. In addition, as cannulae are received through the patient's back, such as when performing minimally invasive spinal surgery, minor blood vessels are ruptured, thereby blocking the surgeon's vision inside the intervertebral region after the cannula has been inserted. nerves as the probe is advanced during minimally-invasive surgery, thus providing a device for guiding the path of other surgical instruments to be inserted into this intervertebral space. In a preferred aspect of the present invention, an expandable tip cannula system is provided which functions both as an access portal for spinal surgery and as a system for nerve surveillance such that the presence and relative position of para-spinal nerves can be detected as the expandable tip cannula is inserted through the patient's facia and para-spinal musculature. An advantage of determining the position of a para-spinal nerve with respect to the distal tip of the cannula in particular is that the para-spinal nerve can be avoided or gently moved out of the surgeon's way while inserting the cannula. Accordingly, in a preferred aspect, the present invention provides a cannulated system which is adapted to assist the surgeon in guiding the path of surgical instruments received into the intervertebral space, while identifying the presence and location of para-spinal nerves as the cannula is advanced to a patient's intervertebral space during minimally invasive surgery.

[0004] Optionally, the present nerve surveillance expandable tip cannula may also be adapted to selectively electrically induce cauterization of severed blood vessels when the cannula or other surgical instruments sever small blood vessels when they are inserted percutaneously into the patient and are advanced along a path into the patient's intervertebral space. An additional advantage of the present cannula system therefore is that, prior to piercing the annulus of an intervertebral disc, vessels on the surface of the disc may be cauterized to assure clear vision inside the disc after surgical entry is made.

[0005] In one embodiment, the present expandable tip nerve surveillance cannula preferably comprises a hollow tubular body with a expandable tip portion mounted at its distal end. In a preferred aspect of the invention, the expandable tip portion comprises a plurality of generally triangular shaped petals which are held together in a radially-inwardly tapering arrangement by breakable seals disposed between adjacent petals. Since the expandable tip portion of the cannula tapers to a narrow blunt end, the cannula can be easily pushed through the patient's facia and spinal musculature using blunt dissection, while minimizing the amount of cutting and tearing of such structures.

[0006] Alternatively, a central electrode can be disposed on a central obturator passing though the cannula and a second electrode can be disposed on a distal end of a second cannula, wherein the second cannula is used to open the petals.

[0007] An obturator shaft which is slidably received within the hollow tubular cannula body provides support for the cannula, giving the cannula sufficient strength such that the cannula can be inserted percutaneously through the patient's facia and para-spinal musculature. Preferably, the obturator has a large solid handle which allows the surgeon to grasp and push the cannula through the resistance of the facia and para-spinal musculature.

[0008] After the cannula has been inserted and is resting on the patient's annulus, a inner cannula or rod which is slidably received within the cannula is then used to separate the breakable seals, opening the petals radially outwards to a distance sufficient to provide access for surgical instruments passing therethrough.

[0009] In some preferred aspects, an electrode is disposed in each of the petals, and most preferably at or near the distal end of each of the petals. In other aspects of the invention, a plurality of electrodes are radially disposed about the distal end of the obturator and the electrodes protrude out of a small hole defined by truncated petals, as will be explained.

[0010] In various aspects of the present invention, the electrodes can be powered at a low level to thereby sense the position of a para-spinal nerve through continuous real time electromyographic monitoring, or alternatively, the electrodes can be powered at a higher level such that they operate to cauterize blood vessels. Safety systems ensure that power levels sufficient to cause cauterization are not activated if a nerve is sensed to be near the electrodes at the distal end of the cannula.

[0011] In alternate embodiments, the present invention comprises an elongated nerve surveillance probe having one or more electrodes at its distal tip. In such aspects, the nerve surveillance probe is preferably advanced to the patient's

intervertebral space through a cannula. In other alternate embodiments, the present nerve surveillance probe is received into the patient through various cannulae and expandable mesh trocars.

BRIEF DESCRIPTION OF THE DRAWINGS

[0012] FIG. 1 is a side perspective view of a first nerve surveillance probe of the present invention.

[0013] FIG. 2 is a sectional side elevation view of the first nerve surveillance probe positioned adjacent the spinal nerve with the first probe received within a first cannula which is itself received with an expandable mesh.

[0014] FIG. 3 shows the probe of FIG. 2, but with the mesh expanded and a second cannula received thereover, (after the distal ends of the first cannula and expandable mesh have been advanced past the nerve).

[0015] FIG. 4 is a sectional side elevation corresponding to FIG. 3, but with the first probe and first cannula removed.

[0016] FIG. 5 is an end view corresponding to FIG. 4.

[0017] FIG. 6 is a side perspective view of a second nerve surveillance probe of the present invention.

[0018] FIG. 7 is a sectional side elevation view of a second nerve surveillance probe received within the second cannula.

[0019] FIG. 8 is an end view corresponding to FIG. 7.

[0020] FIGS. 9A, 9B and 9C sequentially show a schematic view of an expandable mesh system as moved from a contracted position (FIG. 9A) to an expanded position (FIG. 9B), and with an outer cannula received thereover (FIG. 9C).

[0021] FIG. 10 is an end view of the nerve surveillance probe of FIG. 6 pushing a nerve out of the way of an advancing cannula.

[0022] FIG. 11 is an illustration of an expandable tip nerve surveillance probe of the present invention.

[0023] FIG. 12 is a perspective distal view of the system of FIG. 11.

[0024] FIG. 13 is a view of the distal tip of the system of FIG. 12, with the petals in a closed position.

[0025] FIG. 14 is a view corresponding to FIG. 13, but with the petals in an open position.

[0026] FIG. 15 is a sectional view of the system of FIG. 11, with an obturator received therein and the petals in a closed position.

[0027] FIG. 16 is a schematic illustration of the electrodes at the distal tip of the present invention, the electrodes being used to sense the position of a para-spinal nerve.

[0028] FIG. 17 is a sectional view of the system of FIG. 11 with a inner cannula received therein and the petals in an open position.

[0029] FIG. 18 is a side view of an alternate embodiment of the distal tip region of the present invention having truncated petals.

[0030] FIG. 19 is an end view corresponding to FIG. 18.

[0031] FIG. 20 is a top plan view of a peel back expandable tip cannula.

[0032] FIG. 21 is a side elevation view of the peel back cannula FIG. 20.

[0033] FIG. 22 is a side sectional view of the peel back cannula of FIG. 20 in a sealed position.

[0034] FIG. 23 is a sectional side elevation view of the peel back cannula of FIG. 20 in an open position.

[0035] FIG. 24 is a top plan view corresponding to FIG. 23.

[0036] FIG. 25 is a side elevation view of a curved petal nerve surveillance probe.

[0037] FIG. 26 is a side elevation view corresponding to FIG. 25, but with the petals in an open position.

[0038] FIG. 27 is a view corresponding to FIG. 26, but with an expandable elastomer shown wrapped around the distal end of the curved petals.

[0039] FIG. 28 is a sectional elevation view of the distal end of an alternate nerve surveillance cannula.

[0040] FIG. 29 is a perspective view an alternative nerve surveillance probe.

[0041] FIG. 30 shows the surveillance probe of FIG. 29 with the petals opened by an inner cannula.

[0042] FIG. 31 corresponds to FIG. 30, but with the internal obturator removed.

[0043] FIG. 32 corresponds to FIG. 30, but with the internal obturator advanced distally.

[0044] FIG. 33 corresponds to FIG. 31, but with the internal cannula advanced distally.

DESCRIPTION OF THE SPECIFIC EMBODIMENTS

[0045] As will be set forth herein, the present invention encompasses both nerve surveillance probes which are received through cannulae, and various expandable tip cannulae comprising nerve surveillance probes at their distal ends.

[0046] In a first preferred embodiment, as is seen in FIG. 1, an electromyography nerve surveillance probe 10 having a blunt end 11 is provided. Electrode 13 is disposed at the distal end of probe 10 and is charged by electrical contacts 15. As electrode 13 approaches nerve 20 (as seen in FIG. 2), the minimal threshold depolarization value elicited by the electrode will result in corresponding electromyography activity, such that the presence of nerve 20 can be sensed by standard electromyographic techniques, thus indicating the presence of the nerve. Specifically, using standard electromyographic techniques, the presence of nerve 20 will be sensed by appropriate needles or patches attached to the appropriate muscle as electrode 13 stimulates, and thereby depolarizes electrode 13.

[0047] In an exemplary method of application, (as is shown in FIG. 2), the present nerve surveillance probe 10 can be advanced percutaneously through the patient's back in a posterolateral approach towards the patient's intervertebral space using the arrangement in which a first cannula

30 surrounds probe **10** as the probe is advanced. As probe **10** is advanced, it will then become positioned proximal nerve **20**. When this occurs, the presence of nerve **20** relative to probe **10** will be determined by the signal generated by electrode **13** as set forth above.

[0048] In one preferred aspect of the present invention, an expandable mesh **32** is received over first cannula **30** such that expansion of this mesh from the contracted position shown in FIG. 2 to the expanded position shown in FIG. 3 will gently move nerve **20** out of the way.

[0049] Also in a preferred aspect as shown in FIG. 3, a second cannula **34** can thereafter be received over expanded mesh **32**, thereby providing a large passageway **40** for intervertebral access when probe **10**, first cannula **30**, and expanded mesh **32** are removed as shown in FIGS. 4 and 5. Accordingly, the large passageway **40** into the intervertebral area provided by cannula **34** protects sensitive nerve **20** while providing access for surgical instruments there-through, including such surgical instruments as intervertebral inserts, bone decorticators, cameras, articulating forceps, intervertebral inserts and intervertebral positioning systems.

[0050] As is seen in FIG. 6, a second nerve surveillance probe **9** is also provided. Nerve surveillance probe **9** has a plurality of electrodes **12**, **14**, **16** and **18** disposed at radial locations adjacent to blunt distal end **8**, as is seen in FIGS. 6, 7 and 8. Radially-disposed electrodes **12**, **14**, **16**, and **18** perform a variety of useful functions, as follows.

[0051] Referring to FIG. 8, as electrodes **12**, **14**, **16**, and **18** are disposed at radial locations around the tip of probe **10**, the electrodes which are closest to nerve **20**, (in this case electrode **14**, and to a lesser degree electrodes **12** and **16**), will operate to depolarize the nerve such that the presence of nerve **20** can be detected by standard electromyographic techniques. As such, a signal will be generated telling the operating surgeon that nerve **20** is proximal to electrode **14**. As can be appreciated, should nerve **20** instead be positioned in another orientation, the signal from electrodes **12**, **14**, **16** and **18** would instead indicate the presence of the nerve at a different location. Accordingly, probe **9** can be operated as a tool for inspecting the interior passageway of cannula **34** to determine if nerve **20** had become inadvertently trapped therein as cannulae **34** is advanced over expanded mesh **32**. Moreover, as the electrodes **12**, **14**, **16**, and **18** are disposed at radial locations around the distal end of the probe, it is possible to determine the exact location of nerve **20**. Preferably as well, each of electrodes **12**, **14**, **16**, and **18** will be activated in a repeating sequence with a sufficient delay time therebetween to detect an electromyographic response.

[0052] In another aspect of the invention, radially disposed electrodes **12**, **14**, **16**, and **18** can be used for electrocoagulation of blood vessels, for example, blood vessels on the patient's annulus when accessing the patient's intervertebral region. Specifically, as a plurality of electrodes are disposed at the distal end of probe **9**, it is possible to pass current between various electrodes, thus cauterizing adjacent blood vessels.

[0053] In another aspect of the invention, radially disposed electrodes **12**, **14**, **16**, and **18** can be used to assist in avoiding, (or alternatively in moving), nerve **20** as follows. Referring to FIG. 10, nerve **20** will be determined to be

adjacent to electrode **14** using the above set forth method. Probe **10** can then be gently moved in a radial direction away from electrode **14**, as is shown by arrow D, such that nerve **20** can then be gently pushed out of the way, providing safe access to the patient's intervertebral space. Alternatively, the movement of probe **10** in a direction opposite direction D will push the nerve out of the way such that a cannula can then be advanced past nerve **20** without damaging the nerve.

[0054] In another aspect of the present invention as shown in FIGS. 9A, 9B and 9C, the expansion of mesh **32** is controlled as follows. As is shown in FIG. 9A, expandable mesh **32** is in a contracted position and is mounted on the end of a cannula **35**. A distal end of mesh **32** is positioned against the patient's annulus **40** or any other suitably hard bone structure. Pushing rod or cannula **35** in direction D2 will compress mesh **34**, causing it to expand radially and shorten. This movement will displace nerve **20** (shown here in cross section). Following this, cannula **37** can be slid over expanded mesh **32** is seen in FIG. 9B. Following this, cannula **37** can be advanced past nerve **20**, gently pushing nerve **20** still further out of the way, as shown in FIG. 9C. Lastly, rod or cannula **35** and attached mesh **32** can be removed, leaving a large cannulated passageway to the annulus or intervertebral space.

[0055] It is to be understood that the present nerve surveillance probes can be used without the expandable mesh system of FIGS. 9A, 9B and 9C. Moreover, it is to be understood that the present method and apparatus of minimally invasive nerve surveillance can be used in any arthroscopic procedure.

[0056] As can also be appreciated the present nerve surveillance probes are able to detect the presence of any other efferent skeletal motor nerve in addition to the spinal nerve and can thus be used in various surgical procedures. Alternatively, using evoked potential electromyography, the present nerve surveillance probes are also adapted to sense the presence of afferent sensory nerves in response to signals received in the spinal cord or cerebral cortex.

[0057] In a second preferred embodiment, the present invention provides an expandable tip nerve surveillance cannula system **110** comprising an endoscopic hollow cannula shaft **112** having an expandable tip **113** comprised of a plurality of petals **114**, (the details of petals **114** are better shown in FIGS. 12, 13, and 14). System **110** further comprises an obturator **120** which is slidably received within cannula shaft **112**. As is shown in FIG. 15, obturator **120** is a rigid structure which provides internal support to cannula shaft **112** such that cannula shaft **112** can be received percutaneously. Shaft **112** can have a cross section which is circular, oval, racetrack-shaped or any other design. By holding obturator handle **122**, the surgeon is able to advance cannula shaft **112** through the patient's para-spinal musculature and dock expandable tip **113** at the patient's annulus.

[0058] As seen in FIGS. 12 and 13, expandable tip **113** is comprised of a plurality of petals **114**, held together by breakable seals **115**. Breakable seals **115** can be formed by an elastomeric material with predictable failure segments between the petals, which fracture with radial expansion of the petals. In one preferred aspect each of petals **114** has an electrode **116** disposed therein as shown. Electrodes **116** serve the following important functions.

[0059] First, electrodes **116** can be used for electromyography, and in particular to sense the presence and relative

position of para-spinal nerves as cannula shaft 112 is advanced. Referring to FIG. 16, as can be seen electrodes 116a, 116b, 116c, 116d, 116e and 116f are disposed radially about cannula shaft 112, with one electrode disposed in each of petals 114, as has been described. Electrodes 116a, 116b, 116c, 116d, 116e and 116f assist in sensing the presence and location of para-spinal nerve 160 as follows. The electrodes closest to nerve 160, (in this case electrodes 116b and 116d, and to a lesser degree, electrodes 116a and 116d), will operate to depolarize nerve 160 such that the presence of nerve 160 can be detected by electromyography. As such, shaft 112 can be moved in direction D, thereby avoiding nerve 160 as shaft 112 is inserted. Alternatively, of course, shaft 112 can be moved in the opposite direction to D, such that cannula shaft 112 gently moves nerve 112 out of the way. Moreover, when none of electrodes 116a, 116b, 116c, 116d, 116e and 116f sufficiently stimulate to depolarize the nerve, (and thereby assist in its detection), shaft 112 can be safely advanced toward the patient's intervertebral space. Should each one of electrodes 116a, 116b, 116c, 116d, 116e and 116f depolarize the nerve, this would indicate that the nerve is directly in front of the advancing cannula shaft 112. Accordingly, the cannula shaft could be moved such that contact with the nerve is avoided.

[0060] Alternatively, when none of electrodes 116a, 116b, 116c, 116d, 116e and 116f indicate the presence of a nerve, electrodes 116a, 116b, 116c, 116d, 116e and 116f can be powered to a higher level such that cauterization of minor blood vessels can be achieved by passing increased electric current between each of the various adjacent electrodes, thus cauterizing adjacent blood vessels. Preferably, the present invention comprises a safety system such that cauterization power levels for electrodes 116 are not activated when any of electrodes 116 sense the presence of a para-spinal nerve thereby.

[0061] Preferably, each of electrodes 116a, 116b, 116c, 116d, 116e and 116f are operated in sequence, affording a sufficient latency period therebetween for the detection of an electromyographic signal.

[0062] As seen in FIG. 11, button 121 can be used to activate the nerve sensing functions and button 123 can be used to activate the blood vessel cauterization functions. Buttons 121 and 123 are conveniently located on the near handle 122 such that they may be activated while the surgeon grips obturator handle 122.

[0063] Subsequent to being positioned at the patient's annulus, obturator 120 is removed from cannula shaft 112. As seen in FIG. 17, inner cannula 130 is then inserted into cannula shaft 112. Inner cannula 130 is dimensioned to be of a size that, when fully inserted into shaft 112, inner cannula 130 breaks apart seals 115, forcing petals 114 to be displaced radially outwards to a distance of at least the internal diameter of shaft 112 as shown. Inner cannula 130 can alternately comprise a solid rod or obturator which is dimensioned to be received within shaft 112 to open petals 114.

[0064] As can be seen in FIG. 13, a notch 118 is found between adjacent petals 114 where petals 114 are mounted to the distal end 113 of cannula shaft 112. Notches 118 operate to facilitate breakage of seals 115 by providing a stress relief region at the base of breakable seals 115.

[0065] In an alternate design, as shown in FIGS. 18 and 19, distal tip 113 comprises truncated petals 114a which,

when sealed together by way of breakable seals 115, meet at their distal end to define a small opening 117 at distal tip 113 of cannula shaft 112. In this design, an obturator 120a is slidably received within cannula shaft 112. Obturator 120a has a narrow distal end 113a which protrudes through opening 117. Electrodes 119a, 119b, 119c, 119d, 119e and 119f are disposed radially about the narrow distal end 113a of obturator 120a, functioning similar to the probe design shown in FIG. 6.

[0066] In this alternate design of FIGS. 18 and 19, nerve surveillance and blood vessel cauterization functions as described above and as performed by electrodes 116 on petals 114 are instead performed by electrodes 119 on obturator 120a. In this aspect of the invention, petals 114a are truncated and obturator 120a protrudes therethrough.

[0067] In another alternate embodiment, a peel back cannula having an expandable tip is provided. Referring to FIG. 20, cannula 150 is provided. Cannula 150 has a tapered narrow distal end 152 and a tear away line 153 which is formed in the preferred polymeric material of cannula 150. Tear away line 153 will split under tension as will be explained. Cannula 150 may also comprise electrodes 153 which perform a similar function to the electrodes 116 described herein. Electrodes 153 can be disposed axially along the length of cannula 150, or radially around the distal end of cannula 150, or some combination thereof.

[0068] An advantage of being disposed axially along the cannula is that electrodes 153 will be able to sense the position of a nerve relative to the cannula in an axial dimension. Similarly, an advantage of being disposed radially around the cannula is that the electrodes will be able to sense the position of a nerve relative to the cannula in a radial dimension. It is to be understood that all embodiments of the present invention comprise the concept of nerve surveillance electrodes disposed both radially around and axially along the nerve surveillance cannula or obturator, and that the radial electrode placement shown in the design of FIGS. 7, 8 and 11 to 19, and the axial electrode placement shown in the design of FIGS. 20 to 23 is not limiting.

[0069] In a preferred method of operation, cannula 150 is advanced such that its tapered end 152 is adjacent nerve 160 as is seen in FIG. 22. An obturator 155 is positioned within cannula 150. Obturator 155 provides structural support for the cannula as it is being inserted or as it is moving a nerve. Obturator 155 is thereafter removable such that cannula 150 operates as an open passageway as will be explained.

[0070] A narrow inner cannula 157 may also be provided. Cannula 157 is received around obturator 155 and within cannula 150. When the operator has determined it is safe and desirable to open cannula 150, inner cannula 157 is advanced to the position shown in FIGS. 23 and 24. Specifically, inner cannula 157 pushes against the tapered end of 152 of cannula 150 causing cannula 150 to split open along tear away line 153. Accordingly, inner cannula 157 can be used to provide a cannulated passageway when obturator 157 has been withdrawn therefrom. Alternatively, inner cannula 157 can be replaced by a suitably dimensioned obturator for opening cannula 150 along tear away line 153.

[0071] Tear away line 153 may be formed by scribing the polymeric material forming cannula 150. Tear away line 153 preferably runs some distance along opposite sides of the

open 152 of cannula 150. Alternatively, tear away line 153 can be disposed along the top and bottom of cannula 150 as shown.

[0072] FIG. 25 is a side view of a curved petal design of the present invention in a closed position with cannula 220 having outwardly curved petals 212 at distal end 215. A nerve 230 is disposed adjacent the ends of closed petals 212 as shown. Petals 212 are then opened, (using methods described herein), as shown in FIG. 26. The opening of petals 212 causes nerve 230 to be generally displaced upward away from an operative site which may preferably comprise a patient's intervertebral disk 240.

[0073] As shown in FIG. 27, an elastomer 250 can be wrapped around the petals 212 such that nerves are not pinched in gaps 213 between the adjacent petals either when the petals are first opened or when the petals are closed during the removal of the cannula from the patient. It is to be appreciated that elastomer 250 could also be wrapped around the ends of any of the straight petal designs shown in FIGS. 11 to 19.

[0074] The operative site or target site may comprise a patient's intervertebral disk 240 when the present invention is used in minimally invasive spinal surgery. It is to be understood, however, that the present expandable tip cannula can be used in all manner of minimally invasive surgery and is especially useful for approaching any target site having sensitive nerves adjacent thereto since the present invention is specifically adapted to gently push the nerve out of the way as the petals are opened, thereby providing a cannulated access portal for the insertion and removal of various surgical devices through cannula 220.

[0075] FIG. 28 shows an alternate design of the distal end 302 of a nerve surveillance cannula 300. Cannula 300 has a plurality of expanding petals 314, with each petal 314 comprising an electrode 316 adapted for nerve surveillance or blood vessel cauterization as described above. In this aspect of the invention, an obturator 310 protrudes through an opening between petals 314, as shown. As can be seen, obturator 310 may preferably be tapered to a narrow distal end 302, which assists in easing cannula 300 through the patient's fascia and para-spinal musculature and into the patient's intervertebral space. In addition, distal end 302 of obturator 310 can be shaped to latch against the ends of petals 314, as shown, thereby assisting in holding together petals 314 as cannula 300 is advanced.

[0076] Preferably, obturator 310 further comprises a centrally disposed electrode 320. Electrode 320, being axially displaced from electrodes 316 is adapted to sense the position of a nerve in the axial direction as probe 300 approaches the nerve. Subsequent to placement at the patient's intervertebral space, an internal cannula 315 can be advanced distally to open petals 314 with obturator 310 being advanced slightly to first unlatch the distal ends of petals 314 and then withdrawn from cannula 300, providing a cannulated access to the patient's intervertebral space.

[0077] FIG. 29 through 33 show an alternative nerve surveillance cannula and probe system 400, comprising a cannula 402 having a plurality of radially outwardly extending petals 404. An internal obturator 500 is received within cannula 402. Obturator 500 has an electrode 502 disposed at its distal end as shown in FIG. 30. Electrode 502 can also be

seen at distal end of cannula 402 in FIG. 29. Electrode 502 operates to stimulate and thereby, depolarize a nerve as cannula 402 is advanced towards the patient's intervertebral space. FIG. 29 shows cannula 402 with petals 404 closed around electrode 502 as the cannula is advanced.

[0078] FIG. 30 shows an inner cannula 550 which is advanced through cannula 402 to open petals 404 as shown. Inner cannula 550 preferably comprises an electrode 510 which is disposed around the distal end of the cannula, as shown. After inner cannula 550 has opened petals 404, as shown, electrode 502 is turned off and obturator 500 is removed from inner cannula 550 as is shown in FIG. 31. Electrode 510 remains turned on such that it is adapted to detect whether a nerve is positioned close to entering within cannula 550, or whether a surgical instrument advanced through cannula 550 would contact a nerve proximal electrode 510.

[0079] As is shown in FIG. 32, obturator 500 can thereafter be advanced through cannula 550 to bluntly divide and dilate the annulus of a disc. In this aspect of the invention, electrode 502 is turned off as the annulus is divided and dilated. Annular electrode 510 may preferably be turned on during this procedure to sense the presence of nerves adjacent the distal end of cannula 550.

[0080] As is seen in FIG. 33, after the annulus has been divided and dilated, obturator 500 can be withdrawn from cannula 550 with cannula 550 advanced distally into the hole cut into the annulus. As such, a safe cannulated access way into the annulus or other region of the patient's body is provided.

What is claimed is:

1. A system for accessing a surgical target site, comprising:
 - a plurality of tissue displacement members dimensioned to be advanced to a surgical site and moved relative to one another to provide surgical access to said surgical target site; and
 - an expandable member coupled to said plurality of tissue displacement members to prevent tissue from migrating into said surgical target site during surgical access.
2. The system of claim 1, wherein said plurality of tissue displacement members may be at least one of straight and curved in shape.
3. The system of claim 1, wherein said expandable member is coupled to an exterior surface of said plurality of tissue displacement members.
4. The system of claim 1, wherein said expandable member is disposed over at least half of the length of said tissue displacement members.
5. The system of claim 1, wherein said expandable member is disposed over at least seventy-five percent of the length of said tissue displacement members.
6. The system of claim 1, wherein said tissue includes neural tissue.
7. An apparatus for preventing tissue ingress during surgical access, comprising:
 - an expandable member dimensioned to be coupled to a surgical access system to prevent tissue from migrating into a surgical target site during surgical access.
8. The apparatus of claim 7, wherein said surgical access system includes a plurality of tissue displacement members

dimensioned to be advanced to said surgical target site and moved relative to one another to provide surgical access to said surgical target site.

9. The apparatus of claim 8, wherein said plurality of tissue displacement members may be at least one of straight and curved in shape.

10. The apparatus of claim 7, wherein said expandable member is coupled to an exterior surface of said surgical access system.

11. The apparatus of claim 8, wherein said expandable member is disposed over at least half of the length of said tissue displacement members.

12. The apparatus of claim 8, wherein said expandable member is disposed over at least seventy-five percent of the length of said tissue displacement members.

13. The apparatus of claim 7, wherein said tissue includes neural tissue.

14. A method for accessing a surgical site, comprising the steps of:

- (a) coupling an expandable member to a plurality of tissue displacement members;
- (b) advancing the plurality of tissue displacement members to a surgical target site; and

(c) moving said plurality of displacement members relative to one another to provide surgical access to said surgical site, wherein said expandable member prevents tissue from migrating into said surgical target site.

15. The method of claim 14, wherein said plurality of tissue displacement members may be at least one of straight and curved in shape.

16. The method of claim 14, wherein said expandable member is coupled to an exterior surface of said tissue displacement members.

17. The method of claim 14, wherein said expandable member is disposed over at least half of the length of said tissue displacement members.

18. The method of claim 14, wherein said expandable member is disposed over at least seventy-five percent of the length of said tissue displacement members.

19. The method of claim 14, wherein said tissue includes neural tissue.

* * * * *