

[54] **MOTORTRICYCLE**

[75] Inventor: **Hiroshi Shimoyama**, Fujimi, Japan

[73] Assignee: **Honda Giken Kogyo Kabushiki Kaisha**, Tokyo, Japan

[**] Term: **14 Years**

[21] Appl. No.: **62,227**

[22] Filed: **Jul. 30, 1979**

[30] **Foreign Application Priority Data**

Feb. 6, 1979 [JP] Japan 54/4217

[51] Int. Cl. **D12-11**

[52] U.S. Cl. **D12/110**

[58] Field of Search **D12/110, 112, 85; 180/215, 211, 210**

[56] **References Cited**

U.S. PATENT DOCUMENTS

D. 222,242 10/1971 Delaney et al. D12/85

D. 242,439 11/1976 Gervais D12/85
3,713,502 1/1973 Delaney et al. D12/85

FOREIGN PATENT DOCUMENTS

51-413119 1/1976 Japan .
53-487967 11/1978 Japan .
53-412119 12/1978 Japan .
54-49559 2/1979 Japan .

Primary Examiner—James M. Gandy
Attorney, Agent, or Firm—Armstrong, Nikaido,
Marmelstein & Kubovcik

[57] **CLAIM**

The ornamental design for a motortricycle, as shown.

DESCRIPTION

FIG. 1 is a top plan view of a motortricycle showing my new design;
FIG. 2 is a right side elevational view thereof;
FIG. 3 is a left side elevational view thereof;
FIG. 4 is a front elevational view thereof;
FIG. 5 is a rear side elevational view thereof; and
FIG. 6 is a perspective view thereof.

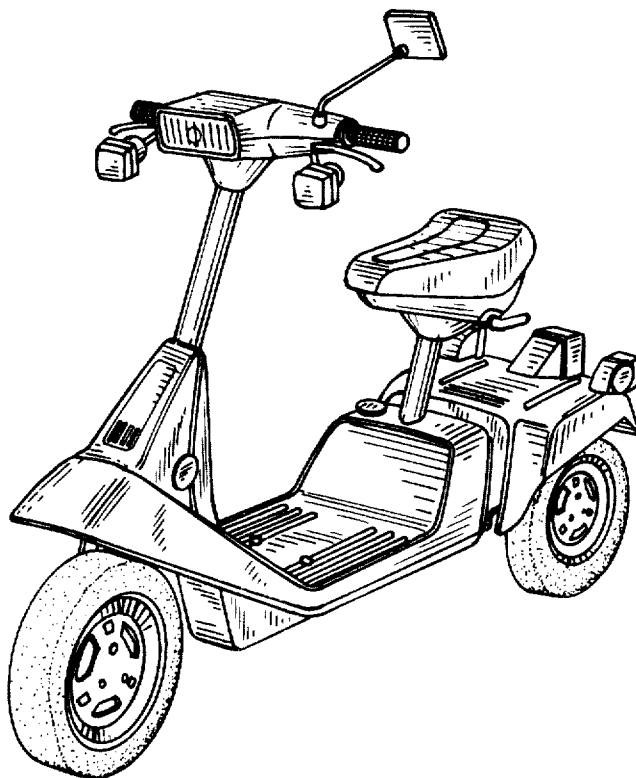

FIG. 1

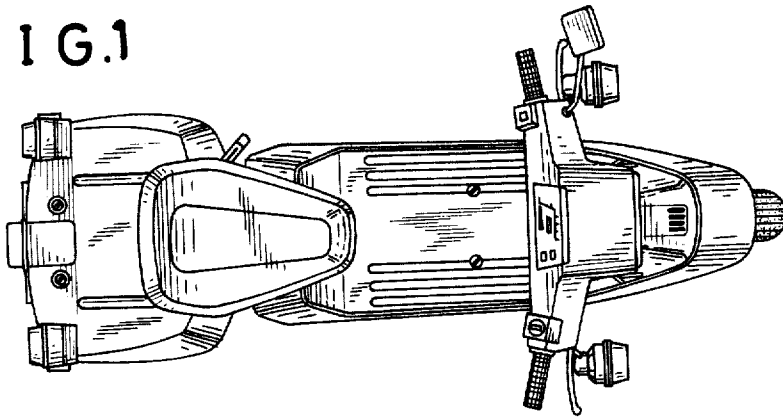

FIG. 2

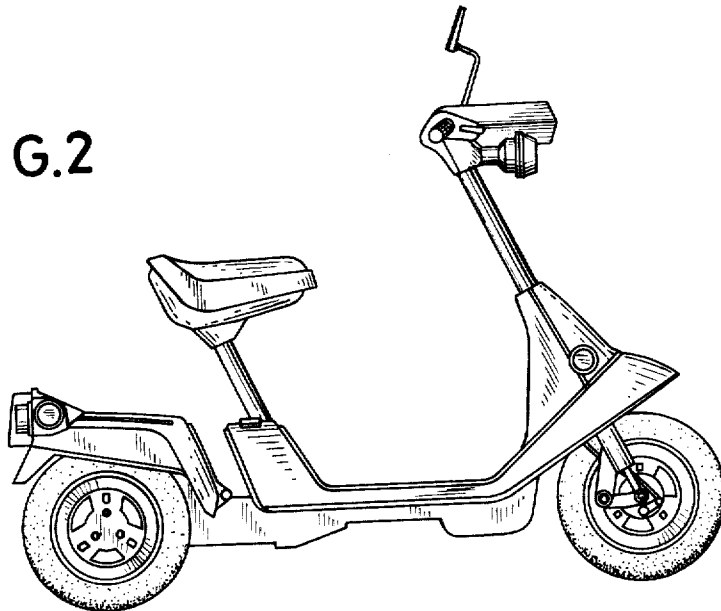

FIG. 3

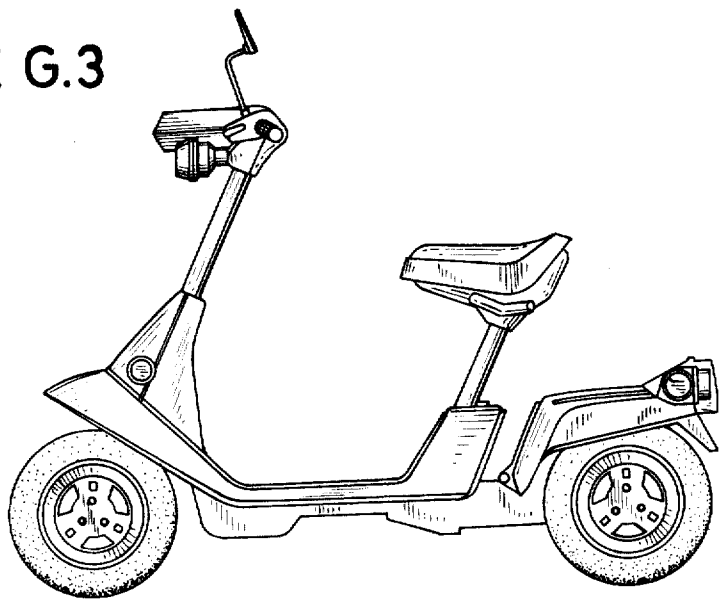

FIG.4

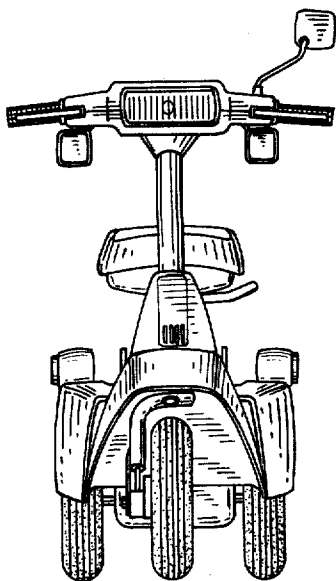

FIG.5

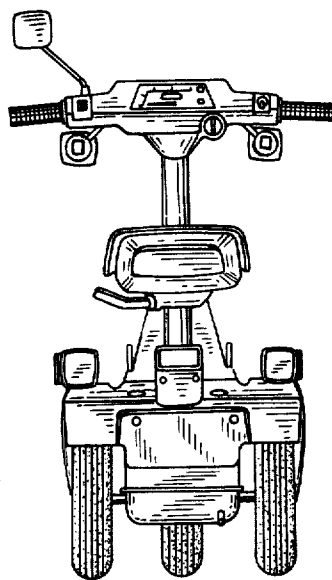

FIG.6

