

(12) STANDARD PATENT
(19) AUSTRALIAN PATENT OFFICE

(11) Application No. **AU 2012348348 B2**

(54) Title
System and method for augmented and virtual reality

(51) International Patent Classification(s)
G09G 5/00 (2006.01)

(21) Application No: **2012348348** (22) Date of Filing: **2012.10.29**

(87) WIPO No: **WO13/085639**

(30) Priority Data

(31) Number	(32) Date	(33) Country
61/552,941	2011.10.28	US

(43) Publication Date: **2013.06.13**

(44) Accepted Journal Date: **2017.03.30**

(71) Applicant(s)
Magic Leap, Inc.

(72) Inventor(s)
Miller, Samuel A.

(74) Agent / Attorney
Davies Collison Cave Pty Ltd, GPO Box 3876, SYDNEY, NSW, 2001, AU

(56) Related Art
US 7642989
US 2008/0024594



- (51) International Patent Classification:
G09G 5/00 (2006.01)
- (21) International Application Number:
PCT/US2012/062500
- (22) International Filing Date:
29 October 2012 (29.10.2012)
- (25) Filing Language: English
- (26) Publication Language: English
- (30) Priority Data:
61/552,941 28 October 2011 (28.10.2011) US
- (71) Applicant (for all designated States except US): **MAGIC LEAP, INC.** [US/US]; 3107 Stirling Road, Suite 102, Fort Lauderdale, FL 3312 (US).
- (72) Inventor; and
- (71) Applicant (for US only): **MILLER, Samuel, A.** [US/US]; 4108 Hayes Street, Hollywood, FL 30021 (US).
- (74) Agent: **LUNDMARK, David, C.**; De Klerk & Lundmark, 906 Seena Avenue, Los Altos, CA 94024 (US).
- (81) Designated States (unless otherwise indicated, for every kind of national protection available): AE, AG, AL, AM,

AO, AT, AU, AZ, BA, BB, BG, BH, BN, BR, BW, BY, BZ, CA, CH, CL, CN, CO, CR, CU, CZ, DE, DK, DM, DO, DZ, EC, EE, EG, ES, FI, GB, GD, GE, GH, GM, GT, HN, HR, HU, ID, IL, IN, IS, JP, KE, KG, KM, KN, KP, KR, KZ, LA, LC, LK, LR, LS, LT, LU, LY, MA, MD, ME, MG, MK, MN, MW, MX, MY, MZ, NA, NG, NI, NO, NZ, OM, PA, PE, PG, PH, PL, PT, QA, RO, RS, RU, RW, SC, SD, SE, SG, SK, SL, SM, ST, SV, SY, TH, TJ, TM, TN, TR, TT, TZ, UA, UG, US, UZ, VC, VN, ZA, ZM, ZW.

- (84) Designated States (unless otherwise indicated, for every kind of regional protection available): ARIPO (BW, GH, GM, KE, LR, LS, MW, MZ, NA, RW, SD, SL, SZ, TZ, UG, ZM, ZW), Eurasian (AM, AZ, BY, KG, KZ, RU, TJ, TM), European (AL, AT, BE, BG, CH, CY, CZ, DE, DK, EE, ES, FI, FR, GB, GR, HR, HU, IE, IS, IT, LT, LU, LV, MC, MK, MT, NL, NO, PL, PT, RO, RS, SE, SI, SK, SM, TR), OAPI (BF, BJ, CF, CG, CI, CM, GA, GN, GQ, GW, ML, MR, NE, SN, TD, TG).

Published:
— with international search report (Art. 21(3))

(54) Title: SYSTEM AND METHOD FOR AUGMENTED AND VIRTUAL REALITY

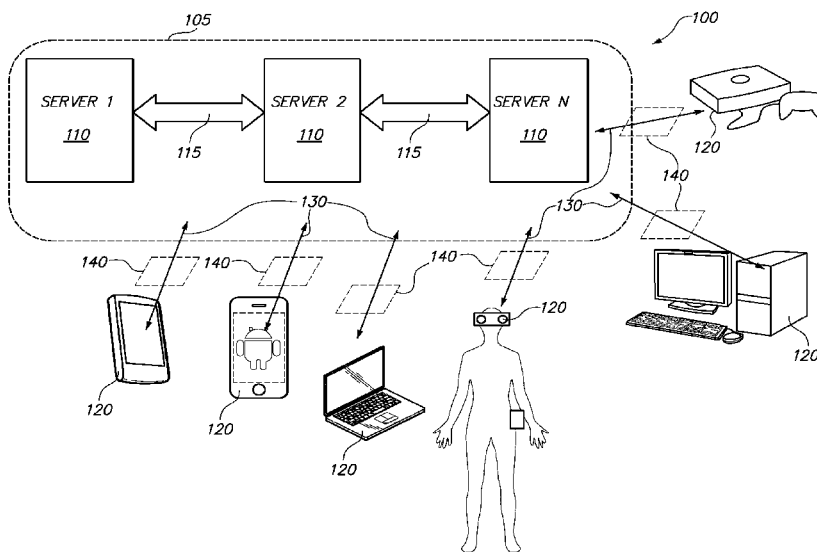

(57) Abstract: One embodiment is directed to a system for enabling two or more users to interact within a virtual world comprising virtual world data, comprising a computer network comprising one or more computing devices, the one or more computing devices comprising memory, processing circuitry, and software stored at least in part in the memory and executable by the processing circuitry to process at least a portion of the virtual world data; wherein at least a first portion of the virtual world data originates from a first user virtual world local to a first user, and wherein the computer network is operable to transmit the first portion to a user device for presentation to a second user, such that the second user may experience the first portion from the location of the second user, such that aspects of the first user virtual world are effectively passed to the second user.

WO 2013/085639 A1

SYSTEM AND METHOD FOR AUGMENTED AND VIRTUAL REALITY

RELATED APPLICATION DATA

The present application claims the benefit under 35 U.S.C. § 119 to U.S. Provisional Applications Serial No. 61/552,941 filed October 28, 2011. The foregoing application is hereby incorporated by reference into the present application in its entirety.

FIELD OF THE INVENTION

The present invention generally relates to systems and methods configured to facilitate interactive virtual or augmented reality environments for one or more users.

BACKGROUND

Virtual and augmented reality environments are generated by computers using, in part, data that describes the environment. This data may describe, for example, various objects with which a user may sense and interact with. Examples of these objects include objects that are rendered and displayed for a user to see, audio that is played for a user to hear, and tactile (or haptic) feedback for a user to feel. Users may sense and interact with the virtual and augmented reality environments through a variety of visual, auditory and tactical means.

SUMMARY

2012348348 12 Nov 2015

One embodiment is directed to a system for enabling two or more users to interact within a virtual world comprising virtual world data, comprising a computer network comprising one or more computing devices, the one or more computing devices comprising memory, processing circuitry, and software stored at least in part in the memory and executable by the processing circuitry to process at least a portion of the virtual world data; and a user device having a wearable user display component, wherein the user device is operatively coupled to the computer network, wherein at least a first portion of the virtual world data comprises a virtual object rendered from and representing a physical object local to a first user, the computer network is operable to transmit the first portion of the virtual world data to the user device associated with a second user, and the wearable user display component visually displays the virtual object to the second user, such that a virtual representation of the physical object local to the first user is visually presented to the second user at the second user's location. The first and second users may be in different physical locations or in substantially the same physical location. At least a portion of the virtual world may be configured to change in response to a change in the virtual world data. At least a portion of the virtual world may be configured to change in response to a physical object sensed by the user device. The change in virtual world data may represent a virtual object having a predetermined relationship with the physical object. The change in virtual world data may be presented to a second user device for presentation to the second user according to the predetermined relationship. The virtual world may be operable to be rendered by at least one of the computer servers or a user device. The virtual world may be presented in a two-dimensional

format. The virtual world may be presented in a three-dimensional format. The user device may be operable to provide an interface for enabling interaction between a user and the virtual world in an augmented reality mode. The user device may be operable to provide an interface for enabling interaction between a user and the virtual world in a virtual reality mode. The user device may be operable to provide an interface for enabling interaction between a user and the virtual world a combination of augmented and virtual reality mode. The virtual world data may be transmitted over a data network. The computer network may be operable to receive at least a portion of the virtual world data from a user device. At least a portion of the virtual world data transmitted to the user device may comprise instructions for generating at least a portion of the virtual world. At least a portion of the virtual world data may be transmitted to a gateway for at least one of processing or distribution. At least one of the one or more computer servers may be operable to process virtual world data distributed by the gateway.

Another embodiment is directed to a system for virtual and/or augmented user experience wherein remote avatars are animated based at least in part upon data on a wearable device with optional input from voice inflection and facial recognition software.

Another embodiment is directed to a system for virtual and/or augmented user experience wherein a camera pose or viewpoint position and vector may be placed anywhere in a world sector.

Another embodiment is directed to a system for virtual and/or augmented user experience wherein worlds or portions

thereof may be rendered for observing users at diverse and selectable scales.

Another embodiment is directed to a system for virtual and/or augmented user experience wherein features, such as points or parametric lines, in addition to pose tagged images, may be utilized as base data for a world model from which software robots, or object recognizers, may be utilized to create parametric representations of real-world objects, tagging source features for mutual inclusion in segmented objects and the world model.

BRIEF DESCRIPTION OF THE DRAWINGS

Figure 1 illustrates a representative embodiment of the disclosed system for facilitating interactive virtual or augmented reality environments for multiple users.

Figure 2 illustrates an example of a user device for interacting with the system illustrated in Figure 1.

Figure 3 illustrates an example embodiment of a mobile, wearable user device.

Figure 4 illustrates an example of objects viewed by a user when the mobile, wearable user device of Figure 3 is operating in an augmented mode.

Figure 5 illustrates an example of objects viewed by a user when the mobile, wearable user device of Figure 3 is operating in a virtual mode.

Figure 6 illustrates an example of objects viewed by a user when the mobile, wearable user device of Figure 3 is operating in a blended virtual interface mode.

Figure 7 illustrates an embodiment wherein two users located in different geographical locations each interact with the other user and a common virtual world through their respective user devices.

Figure 8 illustrates an embodiment wherein the embodiment of Figure 7 is expanded to include the use of a haptic device.

Figure 9A illustrates an example of mixed mode interfacing, wherein a first user is interfacing a digital world in a blended virtual interface mode and a second user is interfacing the same digital world in a virtual reality mode.

Figure 9B illustrates another example of mixed mode interfacing, wherein the first user is interfacing a digital world in a blended virtual interface mode and the second user is interfacing the same digital world in an augmented reality mode.

Figure 10 illustrates an example illustration of a user's view when interfacing the system in an augmented reality mode.

Figure 11 illustrates an example illustration of a user's view showing a virtual object triggered by a physical object when the user is interfacing the system in an augmented reality mode.

Figure 12 illustrates one embodiment of an augmented and virtual reality integration configuration wherein one user in an augmented reality experience visualizes the presence of another user in a virtual reality experience.

Figure 13 illustrates one embodiment of a time and/or contingency event based augmented reality experience configuration.

Figure 14 illustrates one embodiment of a user display configuration suitable for virtual and/or augmented reality experiences.

Figure 15 illustrates one embodiment of local and cloud-based computing coordination.

Figure 16 illustrates various aspects of registration configurations.

DETAILED DESCRIPTION

Referring to Figure 1, system 100 is representative hardware for implementing processes described below. This representative system comprises a computing network 105 comprised of one or more computer servers 110 connected through one or more high bandwidth interfaces 115. The servers in the computing network need not be co-located. The one or more servers 110 each comprise one or more processors for executing program instructions. The servers also include memory for storing the program instructions and data that is used and/or generated by processes being carried out by the servers under direction of the program instructions.

The computing network 105 communicates data between the servers 110 and between the servers and one or more user devices 120 over one or more data network connections 130. Examples of such data networks include, without limitation, any and all types of public and private data networks, both mobile and wired, including for example the interconnection of many of such networks commonly referred to as the Internet. No particular media, topology or protocol is intended to be implied by the figure.

User devices are configured for communicating directly with computing network 105, or any of the servers 110. Alternatively, user devices 120 communicate with the remote servers 110, and, optionally, with other user devices locally, through a specially programmed, local gateway 140 for processing data and/or for communicating data between the network 105 and one or more local user devices 120.

As illustrated, gateway 140 is implemented as a separate hardware component, which includes a processor for executing

software instructions and memory for storing software instructions and data. The gateway has its own wired and/or wireless connection to data networks for communicating with the servers 110 comprising computing network 105. Alternatively, gateway 140 can be integrated with a user device 120, which is worn or carried by a user. For example, the gateway 140 may be implemented as a downloadable software application installed and running on a processor included in the user device 120. The gateway 140 provides, in one embodiment, one or more users access to the computing network 105 via the data network 130.

Servers 110 each include, for example, working memory and storage for storing data and software programs, microprocessors for executing program instructions, graphics processors and other special processors for rendering and generating graphics, images, video, audio and multi-media files. Computing network 105 may also comprise devices for storing data that is accessed, used or created by the servers 110.

Software programs running on the servers and optionally user devices 120 and gateways 140, are used to generate digital worlds (also referred to herein as virtual worlds) with which users interact with user devices 120. A digital world is represented by data and processes that describe and/or define virtual, non-existent entities, environments, and conditions that can be presented to a user through a user device 120 for users to experience and interact with. For example, some type of object, entity or item that will appear to be physically present when instantiated in a scene being viewed or experienced by a user may include a description of its appearance, its behavior, how a user is permitted to interact with it, and other characteristics. Data used to create an environment of a virtual world (including virtual objects) may include, for example,

atmospheric data, terrain data, weather data, temperature data, location data, and other data used to define and/or describe a virtual environment. Additionally, data defining various conditions that govern the operation of a virtual world may include, for example, laws of physics, time, spatial relationships and other data that may be used to define and/or create various conditions that govern the operation of a virtual world (including virtual objects).

The entity, object, condition, characteristic, behavior or other feature of a digital world will be generically referred to herein, unless the context indicates otherwise, as an object (e.g., digital object, virtual object, rendered physical object, etc.). Objects may be any type of animate or inanimate object, including but not limited to, buildings, plants, vehicles, people, animals, creatures, machines, data, video, text, pictures, and other users. Objects may also be defined in a digital world for storing information about items, behaviors, or conditions actually present in the physical world. The data that describes or defines the entity, object or item, or that stores its current state, is generally referred to herein as object data. This data is processed by the servers 110 or, depending on the implementation, by a gateway 140 or user device 120, to instantiate an instance of the object and render the object in an appropriate manner for the user to experience through a user device.

Programmers who develop and/or curate a digital world create or define objects, and the conditions under which they are instantiated. However, a digital world can allow for others to create or modify objects. Once an object is instantiated, the state of the object may be permitted to be altered, controlled

or manipulated by one or more users experiencing a digital world.

For example, in one embodiment, development, production, and administration of a digital world is generally provided by one or more system administrative programmers. In some embodiments, this may include development, design, and/or execution of story lines, themes, and events in the digital worlds as well as distribution of narratives through various forms of events and media such as, for example, film, digital, network, mobile, augmented reality, and live entertainment. The system administrative programmers may also handle technical administration, moderation, and curation of the digital worlds and user communities associated therewith, as well as other tasks typically performed by network administrative personnel.

Users interact with one or more digital worlds using some type of a local computing device, which is generally designated as a user device 120. Examples of such user devices include, but are not limited to, a smart phone, tablet device, heads-up display (HUD), gaming console, or any other device capable of communicating data and providing an interface or display to the user, as well as combinations of such devices. In some embodiments, the user device 120 may include, or communicate with, local peripheral or input/output components such as, for example, a keyboard, mouse, joystick, gaming controller, haptic interface device, motion capture controller, an optical tracking device such as those available from Leap Motion, Inc., or those available from Microsoft under the tradename Kinect (RTM), audio equipment, voice equipment, projector system, 3D display, and holographic 3D contact lens.

An example of a user device 120 for interacting with the system 100 is illustrated in Figure 2. In the example embodiment

shown in Figure 2, a user 210 may interface one or more digital worlds through a smart phone 220. The gateway is implemented by a software application 230 stored on and running on the smart phone 220. In this particular example, the data network 130 includes a wireless mobile network connecting the user device (i.e., smart phone 220) to the computer network 105.

In one implementation of preferred embodiment, system 100 is capable of supporting a large number of simultaneous users (e.g., millions of users), each interfacing with the same digital world, or with multiple digital worlds, using some type of user device 120.

The user device provides to the user an interface for enabling a visual, audible, and/or physical interaction between the user and a digital world generated by the servers 110, including other users and objects (real or virtual) presented to the user. The interface provides the user with a rendered scene that can be viewed, heard or otherwise sensed, and the ability to interact with the scene in real-time. The manner in which the user interacts with the rendered scene may be dictated by the capabilities of the user device. For example, if the user device is a smart phone, the user interaction may be implemented by a user contacting a touch screen. In another example, if the user device is a computer or gaming console, the user interaction may be implemented using a keyboard or gaming controller. User devices may include additional components that enable user interaction such as sensors, wherein the objects and information (including gestures) detected by the sensors may be provided as input representing user interaction with the virtual world using the user device.

The rendered scene can be presented in various formats such as, for example, two-dimensional or three-dimensional visual

displays (including projections), sound, and haptic or tactile feedback. The rendered scene may be interfaced by the user in one or more modes including, for example, augmented reality, virtual reality, and combinations thereof. The format of the rendered scene, as well as the interface modes, may be dictated by one or more of the following: user device, data processing capability, user device connectivity, network capacity and system workload. Having a large number of users simultaneously interacting with the digital worlds, and the real-time nature of the data exchange, is enabled by the computing network 105, servers 110, the gateway component 140 (optionally), and the user device 120.

In one example, the computing network 105 IS comprised of a large-scale computing system having single and/or multi-core servers (i.e., servers 110) connected through high-speed connections (e.g., high bandwidth interfaces 115). The computing network 105 may form a cloud or grid network. Each of the servers includes memory, or is coupled with computer readable memory for storing software for implementing data to create, design, alter, or process objects of a digital world. These objects and their instantiations may be dynamic, come in and out of existence, change over time, and change in response to other conditions. Examples of dynamic capabilities of the objects are generally discussed herein with respect to various embodiments. In some embodiments, each user interfacing the system 100 may also be represented as an object, and/or a collection of objects, within one or more digital worlds.

The servers 110 within the computing network 105 also store computational state data for each of the digital worlds. The computational state data (also referred to herein as state data) may be a component of the object data, and generally defines the

state of an instance of an object at a given instance in time. Thus, the computational state data may change over time and may be impacted by the actions of one or more users and/or programmers maintaining the system 100. As a user impacts the computational state data (or other data comprising the digital worlds), the user directly alters or otherwise manipulates the digital world. If the digital world is shared with, or interfaced by, other users, the actions of the user may affect what is experienced by other users interacting with the digital world. Thus, in some embodiments, changes to the digital world made by a user will be experienced by other users interfacing with the system 100.

The data stored in one or more servers 110 within the computing network 105 is, in one embodiment, transmitted or deployed at a high-speed, and with low latency, to one or more user devices 120 and/or gateway components 140. In one embodiment, object data shared by servers may be complete or may be compressed, and contain instructions for recreating the full object data on the user side, rendered and visualized by the user's local computing device (e.g., gateway 140 and/or user device 120). Software running on the servers 110 of the computing network 105 may, in some embodiments, adapt the data it generates and sends to a particular user's device 120 for objects within the digital world (or any other data exchanged by the computing network 105) as a function of the user's specific device and bandwidth. For example, when a user interacts with a digital world through a user device 120, a server 110 may recognize the specific type of device being used by the user, the device's connectivity and/or available bandwidth between the user device and server, and appropriately size and balance the data being delivered to the device to optimize the user

interaction. An example of this may include reducing the size of the transmitted data to a low resolution quality, so that the data may be displayed on a particular user device having a low resolution display. In a preferred embodiment, the computing network 105 and/or gateway component 140 deliver data to the user device 120 at a rate sufficient to present an interface operating at 15 frames/second or higher, and at a resolution that is high definition quality or greater.

The gateway 140 provides local connection to the computing network 105 for one or more users. In some embodiments, it may be implemented by a downloadable software application that runs on the user device 120 or another local device, such as that shown in Figure 2. In other embodiments, it may be implemented by a hardware component (with appropriate software/firmware stored on the component, the component having a processor) that is either in communication with, but not incorporated with or attracted to, the user device 120, or incorporated with the user device 120. The gateway 140 communicates with the computing network 105 via the data network 130, and provides data exchange between the computing network 105 and one or more local user devices 120. As discussed in greater detail below, the gateway component 140 may include software, firmware, memory, and processing circuitry, and may be capable of processing data communicated between the network 105 and one or more local user devices 120.

In some embodiments, the gateway component 140 monitors and regulates the rate of the data exchanged between the user device 120 and the computer network 105 to allow optimum data processing capabilities for the particular user device 120. For example, in some embodiments, the gateway 140 buffers and downloads both static and dynamic aspects of a digital world,

even those that are beyond the field of view presented to the user through an interface connected with the user device. In such an embodiment, instances of static objects (structured data, software implemented methods, or both) may be stored in memory (local to the gateway component 140, the user device 120, or both) and are referenced against the local user's current position, as indicated by data provided by the computing network 105 and/or the user's device 120. Instances of dynamic objects, which may include, for example, intelligent software agents and objects controlled by other users and/or the local user, are stored in a high-speed memory buffer. Dynamic objects representing a two-dimensional or three-dimensional object within the scene presented to a user can be, for example, broken down into component shapes, such as a static shape that is moving but is not changing, and a dynamic shape that is changing. The part of the dynamic object that is changing can be updated by a real-time, threaded high priority data stream from a server 110, through computing network 105, managed by the gateway component 140. As one example of a prioritized threaded data stream, data that is within a 60 degree field-of-view of the user's eye may be given higher priority than data that is more peripheral. Another example includes prioritizing dynamic characters and/or objects within the user's field-of-view over static objects in the background.

In addition to managing a data connection between the computing network 105 and a user device 120, the gateway component 140 may store and/or process data that may be presented to the user device 120. For example, the gateway component 140 may, in some embodiments, receive compressed data describing, for example, graphical objects to be rendered for viewing by a user, from the computing network 105 and perform

advanced rendering techniques to alleviate the data load transmitted to the user device 120 from the computing network 105. In another example, in which gateway 140 is a separate device, the gateway 140 may store and/or process data for a local instance of an object rather than transmitting the data to the computing network 105 for processing.

Referring now also to Figure 3, the digital worlds may be experienced by one or more users in various formats that may depend upon the capabilities of the user's device. In some embodiments, the user device 120 may include, for example, a smart phone, tablet device, heads-up display (HUD), gaming console, or a wearable device. Generally, the user device will include a processor for executing program code stored in memory on the device, coupled with a display, and a communications interface. An example embodiment of a user device is illustrated in Figure 3, wherein the user device comprises a mobile, wearable device, namely a head-mounted display system 300. In accordance with an embodiment of the present disclosure, the head-mounted display system 300 includes a user interface 302, user-sensing system 304, environment-sensing system 306, and a processor 308. Although the processor 308 is shown in Figure 3 as an isolated component separate from the head-mounted system 300, in an alternate embodiment, the processor 308 may be integrated with one or more components of the head-mounted system 300, or may be integrated into other system 100 components such as, for example, the gateway 140.

The user device presents to the user an interface 302 for interacting with and experiencing a digital world. Such interaction may involve the user and the digital world, one or more other users interfacing the system 100, and objects within the digital world. The interface 302 generally provides image

and/or audio sensory input (and in some embodiments, physical sensory input) to the user. Thus, the interface 302 may include speakers (not shown) and a display component 303 capable, in some embodiments, of enabling stereoscopic 3D viewing and/or 3D viewing which embodies more natural characteristics of the human vision system. In some embodiments, the display component 303 may comprise a transparent interface (such as a clear OLED) which, when in an "off" setting, enables an optically correct view of the physical environment around the user with little-to-no optical distortion or computing overlay. As discussed in greater detail below, the interface 302 may include additional settings that allow for a variety of visual/interface performance and functionality.

The user-sensing system 304 may include, in some embodiments, one or more sensors 310 operable to detect certain features, characteristics, or information related to the individual user wearing the system 300. For example, in some embodiments, the sensors 310 may include a camera or optical detection/scanning circuitry capable of detecting real-time optical characteristics/measurements of the user such as, for example, one or more of the following: pupil constriction/dilation, angular measurement/positioning of each pupil, sphericity, eye shape (as eye shape changes over time) and other anatomic data. This data may provide, or be used to calculate, information (e.g., the user's visual focal point) that may be used by the head-mounted system 300 and/or interface system 100 to optimize the user's viewing experience. For example, in one embodiment, the sensors 310 may each measure a rate of pupil contraction for each of the user's eyes. This data may be transmitted to the processor 308 (or the gateway component 140 or to a server 110), wherein the data is used to

determine, for example, the user's reaction to a brightness setting of the interface display 303. The interface 302 may be adjusted in accordance with the user's reaction by, for example, dimming the display 303 if the user's reaction indicates that the brightness level of the display 303 is too high. The user-sensing system 304 may include other components other than those discussed above or illustrated in Figure 3. For example, in some embodiments, the user-sensing system 304 may include a microphone for receiving voice input from the user. The user sensing system may also include one or more infrared camera sensors, one or more visible spectrum camera sensors, structured light emitters and/or sensors, infrared light emitters, coherent light emitters and/or sensors, gyros, accelerometers, magnetometers, proximity sensors, GPS sensors, ultrasonic emitters and detectors and haptic interfaces.

The environment-sensing system 306 includes one or more sensors 312 for obtaining data from the physical environment around a user. Objects or information detected by the sensors may be provided as input to the user device. In some embodiments, this input may represent user interaction with the virtual world. For example, a user viewing a virtual keyboard on a desk may gesture with his fingers as if he were typing on the virtual keyboard. The motion of the fingers moving may be captured by the sensors 312 and provided to the user device or system as input, wherein the input may be used to change the virtual world or create new virtual objects. For example, the motion of the fingers may be recognized (using a software program) as typing, and the recognized gesture of typing may be combined with the known location of the virtual keys on the virtual keyboard. The system may then render a virtual monitor displayed to the user (or other users interfacing the system)

wherein the virtual monitor displays the text being typed by the user.

The sensors 312 may include, for example, a generally outward-facing camera or a scanner for interpreting scene information, for example, through continuously and/or intermittently projected infrared structured light. The environment-sensing system 306 may be used for mapping one or more elements of the physical environment around the user by detecting and registering the local environment, including static objects, dynamic objects, people, gestures and various lighting, atmospheric and acoustic conditions. Thus, in some embodiments, the environment-sensing system 306 may include image-based 3D reconstruction software embedded in a local computing system (e.g., gateway component 140 or processor 308) and operable to digitally reconstruct one or more objects or information detected by the sensors 312. In one exemplary embodiment, the environment-sensing system 306 provides one or more of the following: motion capture data (including gesture recognition), depth sensing, facial recognition, object recognition, unique object feature recognition, voice/audio recognition and processing, acoustic source localization, noise reduction, infrared or similar laser projection, as well as monochrome and/or color CMOS sensors (or other similar sensors), field-of-view sensors, and a variety of other optical-enhancing sensors. It should be appreciated that the environment-sensing system 306 may include other components other than those discussed above or illustrated in Figure 3. For example, in some embodiments, the environment-sensing system 306 may include a microphone for receiving audio from the local environment. The user sensing system may also include one or more infrared camera sensors, one or more visible spectrum camera sensors, structure

light emitters and/or sensors, infrared light emitters, coherent light emitters and/or sensors gyros, accelerometers, magnetometers, proximity sensors, GPS sensors, ultrasonic emitters and detectors and haptic interfaces.

As mentioned above, the processor 308 may, in some embodiments, be integrated with other components of the head-mounted system 300, integrated with other components of the interface system 100, or may be an isolated device (wearable or separate from the user) as shown in Figure 3. The processor 308 may be connected to various components of the head-mounted system 300 and/or components of the interface system 100 through a physical, wired connection, or through a wireless connection such as, for example, mobile network connections (including cellular telephone and data networks), Wi-Fi or Bluetooth. The processor 308 may include a memory module, integrated and/or additional graphics processing unit, wireless and/or wired internet connectivity, and codec and/or firmware capable of transforming data from a source (e.g., the computing network 105, the user-sensing system 304, the environment-sensing system 306, or the gateway component 140) into image and audio data, wherein the images/video and audio may be presented to the user via the interface 302.

The processor 308 handles data processing for the various components of the headmounted system 300 as well as data exchange between the head-mounted system 300 and the gateway component 140 and, in some embodiments, the computing network 105. For example, the processor 308 may be used to buffer and process data streaming between the user and the computing network 105, thereby enabling a smooth, continuous and high fidelity user experience. In some embodiments, the processor 308 may process data at a rate sufficient to achieve anywhere

between 8 frames/second at 320x240 resolution to 24 frames/second at high definition resolution (1280x720), or greater, such as 60-120 frames/second and 4k resolution and higher (10k+ resolution and 50,000 frames/second). Additionally, the processor 308 may store and/or process data that may be presented to the user, rather than streamed in real-time from the computing network 105. For example, the processor 308 may, in some embodiments, receive compressed data from the computing network 105 and perform advanced rendering techniques (such as lighting or shading) to alleviate the data load transmitted to the user device 120 from the computing network 105. In another example, the processor 308 may store and/or process local object data rather than transmitting the data to the gateway component 140 or to the computing network 105.

The head-mounted system 300 may, in some embodiments, include various settings, or modes, that allow for a variety of visual/interface performance and functionality. The modes may be selected manually by the user, or automatically by components of the head-mounted system 300 or the gateway component 140. As previously mentioned, one example of headmounted system 300 includes an "off" mode, wherein the interface 302 provides substantially no digital or virtual content. In the off mode, the display component 303 may be transparent, thereby enabling an optically correct view of the physical environment around the user with little-to-no optical distortion or computing overlay.

In one example embodiment, the head-mounted system 300 includes an "augmented" mode, wherein the interface 302 provides an augmented reality interface. In the augmented mode, the interface display 303 may be substantially transparent, thereby allowing the user to view the local, physical environment. At the same time, virtual object data provided by the computing

network 105, the processor 308, and/or the gateway component 140 is presented on the display 303 in combination with the physical, local environment.

Figure 4 illustrates an example embodiment of objects viewed by a user when the interface 302 is operating in an augmented mode. As shown in Figure 4, the interface 302 presents a physical object 402 and a virtual object 404. In the embodiment illustrated in Figure 4, the physical object 402 is a real, physical object existing in the local environment of the user, whereas the virtual object 404 is an object created by the system 100, and displayed via the user interface 302. In some embodiments, the virtual object 404 may be displayed at a fixed position or location within the physical environment (e.g., a virtual monkey standing next to a particular street sign located in the physical environment), or may be displayed to the user as an object located at a position relative to the user interface/display 303 (e.g., a virtual clock or thermometer visible in the upper, left corner of the display 303).

In some embodiments, virtual objects may be made to be cued off of, or triggered by, an object physically present within or outside a user's field of view. Virtual object 404 is cued off, or triggered by, the physical object 402. For example, the physical object 402 may actually be a stool, and the virtual object 404 may be displayed to the user (and, in some embodiments, to other users interfacing the system 100) as a virtual animal standing on the stool. In such an embodiment, the environment-sensing system 306 may use software and/or firmware stored, for example, in the processor 308 to recognize various features and/or shape patterns (captured by the sensors 312) to identify the physical object 402 as a stool. These recognized shape patterns such as, for example, the stool top, may be used

to trigger the placement of the virtual object 404. Other examples include walls, tables, furniture, cars, buildings, people, floors, plants, animals - any object which can be seen can be used to trigger an augmented reality experience in some relationship to the object or objects.

In some embodiments, the particular virtual object 404 that is triggered may be selected by the user or automatically selected by other components of the head-mounted system 300 or interface system 100. Additionally, in embodiments in which the virtual object 404 is automatically triggered, the particular virtual object 404 may be selected based upon the particular physical object 402 (or feature thereof) off which the virtual object 404 is cued or triggered. For example, if the physical object is identified as a diving board extending over a pool, the triggered virtual object may be a creature wearing a snorkel, bathing suit, floatation device, or other related items.

In another example embodiment, the head-mounted system 300 may include a "virtual" mode, wherein the interface 302 provides a virtual reality interface. In the virtual mode, the physical environment is omitted from the display 303, and virtual object data provided by the computing network 105, the processor 308, and/or the gateway component 140 is presented on the display 303. The omission of the physical environment may be accomplished by physically blocking the visual display 303 (e.g., via a cover) or through a feature of the interface 302 wherein the display 303 transitions to an opaque setting. In the virtual mode, live and/or stored visual and audio sensory may be presented to the user through the interface 302, and the user experiences and interacts with a digital world (digital objects, other users, etc.) through the virtual mode of the interface

302. Thus, the interface provided to the user in the virtual mode is comprised of virtual object data comprising a virtual, digital world.

Figure 5 illustrates an example embodiment of a user interface when the headmounted interface 302 is operating in a virtual mode. As shown in Figure 5, the user interface presents a virtual world 500 comprised of digital objects 510, wherein the digital objects 510 may include atmosphere, weather, terrain, buildings, and people. Although it is not illustrated in Figure 5, digital objects may also include, for example, plants, vehicles, animals, creatures, machines, artificial intelligence, location information, and any other object or information defining the virtual world 500.

In another example embodiment, the head-mounted system 300 may include a "blended" mode, wherein various features of the head-mounted system 300 (as well as features of the virtual and augmented modes) may be combined to create one or more custom interface modes. In one example custom interface mode, the physical environment is omitted from the display 303, and virtual object data is presented on the display 303 in a manner similar to the virtual mode. However, in this example custom interface mode, virtual objects may be fully virtual (i.e., they do not exist in the local, physical environment) or they may be real, local, physical objects rendered as a virtual object in the interface 302 in place of the physical object. Thus, in this particular custom mode (referred to herein as a blended virtual interface mode), live and/or stored visual and audio sensory may be presented to the user through the interface 302, and the user experiences and interacts with a digital world comprising fully virtual objects and rendered physical objects.

Figure 6 illustrates an example embodiment of a user interface operating in accordance with the blended virtual interface mode. As shown in Figure 6, the user interface presents a virtual world 600 comprised of fully virtual objects 610, and rendered physical objects 620 (renderings of objects otherwise physically present in the scene). In accordance with the example illustrated in Figure 6, the rendered physical objects 620 include a building 620A, ground 620B, and a platform 620C, and are shown with a bolded outline 630 to indicate to the user that the objects are rendered. Additionally, the fully virtual objects 610 include an additional user 610A, clouds 610B, sun 610C, and flames 610D on top of the platform 620C. It should be appreciated that fully virtual objects 610 may include, for example, atmosphere, weather, terrain, buildings, people, plants, vehicles, animals, creatures, machines, artificial intelligence, location information, and any other object or information defining the virtual world 600, and not rendered from objects existing in the local, physical environment. Conversely, the rendered physical objects 620 are real, local, physical objects rendered as a virtual object in the interface 302. The bolded outline 630 represents one example for indicating rendered physical objects to a user. As such, the rendered physical objects may be indicated as such using methods other than those disclosed herein.

In some embodiments, the rendered physical objects 620 may be detected using the sensors 312 of the environment-sensing system 306 (or using other devices such as a motion or image capture system), and converted into digital object data by software and/or firmware stored, for example, in the processing circuitry 308. Thus, as the user interfaces with the system 100 in the blended virtual interface mode, various physical objects

may be displayed to the user as rendered physical objects. This may be especially useful for allowing the user to interface with the system 100, while still being able to safely navigate the local, physical environment. In some embodiments, the user may be able to selectively remove or add the rendered physical objects to the interface display 303.

In another example custom interface mode, the interface display 303 may be substantially transparent, thereby allowing the user to view the local, physical environment, while various local, physical objects are displayed to the user as rendered physical objects. This example custom interface mode is similar to the augmented mode, except that one or more of the virtual objects may be rendered physical objects as discussed above with respect to the previous example.

The foregoing example custom interface modes represent a few example embodiments of various custom interface modes capable of being provided by the blended mode of the head-mounted system 300. Accordingly, various other custom interface modes may be created from the various combination of features and functionality provided by the components of the headmounted system 300 and the various modes discussed above without departing from the scope of the present disclosure.

The embodiments discussed herein merely describe a few examples for providing an interface operating in an off, augmented, virtual, or blended mode, and are not intended to limit the scope or content of the respective interface modes or the functionality of the components of the head-mounted system 300. For example, in some embodiments, the virtual objects may include data displayed to the user (time, temperature, elevation, etc.), objects created and/or selected by the system 100, objects created and/or selected by a user, or even objects

representing other users interfacing the system 100. Additionally, the virtual objects may include an extension of physical objects (e.g., a virtual sculpture growing from a physical platform) and may be visually connected to, or disconnected from, a physical object.

The virtual objects may also be dynamic and change with time, change in accordance with various relationships (e.g., location, distance, etc.) between the user or other users, physical objects, and other virtual objects, and/or change in accordance with other variables specified in the software and/or firmware of the head-mounted system 300, gateway component 140, or servers 110. For example, in certain embodiments, a virtual object may respond to a user device or component thereof (e.g., a virtual ball moves when a haptic device is placed next to it), physical or verbal user interaction (e.g., a virtual creature runs away when the user approaches it, or speaks when the user speaks to it), a chair is thrown at a virtual creature and the creature dodges the chair, other virtual objects (e.g., a first virtual creature reacts when it sees a second virtual creature), physical variables such as location, distance, temperature, time, etc. or other physical objects in the user's environment (e.g., a virtual creature shown standing in a physical street becomes flattened when a physical car passes).

The various modes discussed herein may be applied to user devices other than the head-mounted system 300. For example, an augmented reality interface may be provided via a mobile phone or tablet device. In such an embodiment, the phone or tablet may use a camera to capture the physical environment around the user, and virtual objects may be overlaid on the phone/tablet display screen. Additionally, the virtual mode may be provided by displaying the digital world on the display screen of the

phone/tablet. Accordingly, these modes may be blended as to create various custom interface modes as described above using the components of the phone/tablet discussed herein, as well as other components connected to, or used in combination with, the user device. For example, the blended virtual interface mode may be provided by a computer monitor, television screen, or other device lacking a camera operating in combination with a motion or image capture system. In this example embodiment, the virtual world may be viewed from the monitor/screen and the object detection and rendering may be performed by the motion or image capture system.

Figure 7 illustrates an example embodiment of the present disclosure, wherein two users located in different geographical locations each interact with the other user and a common virtual world through their respective user devices. In this embodiment, the two users 701 and 702 are throwing a virtual ball 703 (a type of virtual object) back and forth, wherein each user is capable of observing the impact of the other user on the virtual world (e.g., each user observes the virtual ball changing directions, being caught by the other user, etc.). Since the movement and location of the virtual objects (i.e., the virtual ball 703) are tracked by the servers 110 in the computing network 105, the system 100 may, in some embodiments, communicate to the users 701 and 702 the exact location and timing of the arrival of the ball 703 with respect to each user. For example, if the first user 701 is located in London, the user 701 may throw the ball 703 to the second user 702 located in Los Angeles at a velocity calculated by the system 100. Accordingly, the system 100 may communicate to the second user 702 (e.g., via email, text message, instant message, etc.) the exact time and location of the ball's arrival. As such, the

second user 702 may use his device to see the ball 703 arrive at the specified time and located. One or more users may also use geo-location mapping software (or similar) to track one or more virtual objects as they travel virtually across the globe. An example of this may be a user wearing a 3D head-mounted display looking up in the sky and seeing a virtual plane flying overhead, superimposed on the real world. The virtual plane may be flown by the user, by intelligent software agents (software running on the user device or gateway), other users who may be local and/or remote, and/or any of these combinations.

As previously mentioned, the user device may include a haptic interface device, wherein the haptic interface device provides a feedback (e.g., resistance, vibration, lights, sound, etc.) to the user when the haptic device is determined by the system 100 to be located at a physical, spatial location relative to a virtual object. For example, the embodiment described above with respect to Figure 7 may be expanded to include the use of a haptic device 802, as shown in Figure 8.

In this example embodiment, the haptic device 802 may be displayed in the virtual world as a baseball bat. When the ball 703 arrives, the user 702 may swing the haptic device 802 at the virtual ball 703. If the system 100 determines that the virtual bat provided by the haptic device 802 made "contact" with the ball 703, then the haptic device 802 may vibrate or provide other feedback to the user 702, and the virtual ball 703 may ricochet off the virtual bat in a direction calculated by the system 100 in accordance with the detected speed, direction, and timing of the ball-to-bat contact.

The disclosed system 100 may, in some embodiments, facilitate mixed mode interfacing, wherein multiple users may interface a common virtual world (and virtual objects contained

therein) using different interface modes (e.g., augmented, virtual, blended, etc.). For example, a first user interfacing a particular virtual world in a virtual interface mode may interact with a second user interfacing the same virtual world in an augmented reality mode.

Figure 9A illustrates an example wherein a first user 901 (interfacing a digital world of the system 100 in a blended virtual interface mode) and first object 902 appear as virtual objects to a second user 922 interfacing the same digital world of the system 100 in a full virtual reality mode. As described above, when interfacing the digital world via the blended virtual interface mode, local, physical objects (e.g., first user 901 and first object 902) may be scanned and rendered as virtual objects in the virtual world. The first user 901 may be scanned, for example, by a motion capture system or similar device, and rendered in the virtual world (by software/firmware stored in the motion capture system, the gateway component 140, the user device 120, system servers 110, or other devices) as a first rendered physical object 931. Similarly, the first object 902 may be scanned, for example, by the environment-sensing system 306 of a head-mounted interface 300, and rendered in the virtual world (by software/firmware stored in the processor 308, the gateway component 140, system servers 110, or other devices) as a second rendered physical object 932. The first user 901 and first object 902 are shown in a first portion 910 of Figure 9A as physical objects in the physical world. In a second portion 920 of Figure 9A, the first user 901 and first object 902 are shown as they appear to the second user 922 interfacing the same digital world of the system 100 in a full virtual reality mode: as the first rendered physical object 931 and second rendered physical object 932.

Figure 9B illustrates another example embodiment of mixed mode interfacing, wherein the first user 901 is interfacing the digital world in a blended virtual interface mode, as discussed above, and the second user 922 is interfacing the same digital world (and the second user's physical, local environment 925) in an augmented reality mode. In the embodiment in Figure 9B, the first user 901 and first object 902 are located at a first physical location 915, and the second user 922 is located at a different, second physical location 925 separated by some distance from the first location 915. In this embodiment, the virtual objects 931 and 932 may be transposed in realtime (or near real-time) to a location within the virtual world corresponding to the second location 925. Thus, the second user 922 may observe and interact, in the second user's physical, local environment 925, with the rendered physical objects 931 and 932 representing the first user 901 and first object 902, respectively.

Figure 10 illustrates an example illustration of a user's view when interfacing the system 100 in an augmented reality mode. As shown in Figure 10, the user sees the local, physical environment (i.e., a city having multiple buildings) as well as a virtual character 1010 (i.e., virtual object). The position of the virtual character 1010 may be triggered by a 2D visual target (for example, a billboard, postcard or magazine) and/or one or more 3D reference frames such as buildings, cars, people, animals, airplanes, portions of a building, and/or any 3D physical object, virtual object, and/or combinations thereof. In the example illustrated in Figure 10, the known position of the buildings in the city may provide the registration fiducials and/or information and key features for rendering the virtual character 1010. Additionally, the user's geospatial location

(e.g., provided by GPS, attitude/position sensors, etc.) or mobile location relative to the buildings, may comprise data used by the computing network 105 to trigger the transmission of data used to display the virtual character(s) 1010. In some embodiments, the data used to display the virtual character 1010 may comprise the rendered character 1010 and/or instructions (to be carried out by the gateway component 140 and/or user device 120) for rendering the virtual character 1010 or portions thereof. In some embodiments, if the geospatial location of the user is unavailable or unknown, a server 110, gateway component 140, and/or user device 120 may still display the virtual object 1010 using an estimation algorithm that estimates where particular virtual objects and/or physical objects may be located, using the user's last known position as a function of time and/or other parameters. This may also be used to determine the position of any virtual objects should the user's sensors become occluded and/or experience other malfunctions.

In some embodiments, virtual characters or virtual objects may comprise a virtual statue, wherein the rendering of the virtual statue is triggered by a physical object. For example, referring now to Figure 11, a virtual statue 1110 may be triggered by a real, physical platform 1120. The triggering of the statue 1110 may be in response to a visual object or feature (e.g., fiducials, design features, geometry, patterns, physical location, altitude, etc.) detected by the user device or other components of the system 100. When the user views the platform 1120 without the user device, the user sees the platform 1120 with no statue 1110. However, when the user views the platform 1120 through the user device, the user sees the statue 1110 on the platform 1120 as shown in Figure 11. The statue 1110 is a virtual object and, therefore, may be stationary, animated,

change over time or with respect to the user's viewing position, or even change depending upon which particular user is viewing the statue 1110. For example, if the user is a small child, the statue may be a dog; yet, if the viewer is an adult male, the statue may be a large robot as shown in Figure 11. These are examples of user dependent and/or state dependent experiences. This will enable one or more users to perceive one or more virtual objects alone and/or in combination with physical objects and experience customized and personalized versions of the virtual objects. The statue 1110 (or portions thereof) may be rendered by various components of the system including, for example, software/firmware installed on the user device. Using data indicating the location and attitude of the user device, in combination with the registration features of the virtual object (i.e., statue 1110), the virtual object (i.e., statue 1110) forms a relationship with the physical object (i.e., platform 1120). For example, the relationship between one or more virtual objects with one or more physical objects may be a function of distance, positioning, time, geo-location, proximity to one or more other virtual objects, and/or any other functional relationship that includes virtual and/or physical data of any kind. In some embodiments, image recognition software in the user device may further enhance the digital-to-physical object relationship.

The interactive interface provided by the disclosed system and method may be implemented to facilitate various activities such as, for example, interacting with one or more virtual environments and objects, interacting with other users, as well as experiencing various forms of media content, including advertisements, music concerts, and movies. Accordingly, the disclosed system facilitates user interaction such that the user

not only views or listens to the media content, but rather, actively participates in and experiences the media content. In some embodiments, the user participation may include altering existing content or creating new content to be rendered in one or more virtual worlds. In some embodiments, the media content, and/or users creating the content, may be themed around a mythopoeia of one or more virtual worlds.

In one example, musicians (or other users) may create musical content to be rendered to users interacting with a particular virtual world. The musical content may include, for example, various singles, EPs, albums, videos, short films, and concert performances. In one example, a large number of users may interface the system 100 to simultaneously experience a virtual concert performed by the musicians.

In some embodiments, the media produced may contain a unique identifier code associated with a particular entity (e.g., a band, artist, user, etc.). The code may be in the form of a set of alphanumeric characters, UPC codes, QR codes, 2D image triggers, 3D physical object feature triggers, or other digital mark, as well as a sound, image, and/or both. In some embodiments, the code may also be embedded with digital media which may be interfaced using the system 100. A user may obtain the code (e.g., via payment of a fee) and redeem the code to access the media content produced by the entity associated with the identifier code. The media content may be added or removed from the user's interface.

In one embodiment, to avoid the computation and bandwidth limitations of passing realtime or near realtime video data from one computing system to another with low latency, such as from a cloud computing system to a local processor coupled to a user, parametric information regarding various shapes and geometries

may be transferred and utilized to define surfaces, while textures maybe transferred and added to these surfaces to bring about static or dynamic detail, such as bitmap-based video detail of a person's face mapped upon a parametrically reproduced face geometry. As another example, if a system is configured to recognize a person's face, and knows that the person's avatar is located in an augmented world, the system may be configured to pass the pertinent world information and the person's avatar information in one relatively large setup transfer, after which remaining transfers to a local computing system, such as that 308 depicted in Figure 1, for local rendering may be limited to parameter and texture updates, such as to motion parameters of the person's skeletal structure and moving bitmaps of the person's face - all at orders of magnitude less bandwidth relative to the initial setup transfer or passing of realtime video. Cloud-based and local computing assets thus may be used in an integrated fashion, with the cloud handling computation that does not require relatively low latency, and the local processing assets handling tasks wherein low latency is at a premium, and in such case, the form of data transferred to the local systems preferably is passed at relatively low bandwidth due to the form an amount of such data (i.e., parametric info, textures, etc versus realtime video of everything).

Referring ahead to Figure 15, a schematic illustrates coordination between cloud computing assets (46) and local processing assets (308, 120). In one embodiment, the cloud (46) assets are operatively coupled, such as via wired or wireless networking (wireless being preferred for mobility, wired being preferred for certain high-bandwidth or high-data-volume transfers that may be desired), directly to (40, 42) one or both

of the local computing assets (120, 308), such as processor and memory configurations which may be housed in a structure configured to be coupled to a user's head (120) or belt (308). These computing assets local to the user may be operatively coupled to each other as well, via wired and/or wireless connectivity configurations (44). In one embodiment, to maintain a low-inertia and small-size head mounted subsystem (120), primary transfer between the user and the cloud (46) may be via the link between the belt-based subsystem (308) and the cloud, with the head mounted subsystem (120) primarily data-tethered to the belt-based subsystem (308) using wireless connectivity, such as ultra-wideband ("UWB") connectivity, as is currently employed, for example, in personal computing peripheral connectivity applications.

With efficient local and remote processing coordination, and an appropriate display device for a user, such as the user interface 302 or user "display device" featured in Figure 3, the display device 14 described below in reference to Figure 14, or variations thereof, aspects of one world pertinent to a user's current actual or virtual location may be transferred or "passed" to the user and updated in an efficient fashion. Indeed, in one embodiment, with one person utilizing a virtual reality system ("VRS") in an augmented reality mode and another person utilizing a VRS in a completely virtual mode to explore the same world local to the first person, the two users may experience one another in that world in various fashions. For example, referring to Figure 12, a scenario similar to that described in reference to Figure 11 is depicted, with the addition of a visualization of an avatar 2 of a second user who is flying through the depicted augmented reality world from a completely virtual reality scenario. In other words, the scene

depicted in Figure 12 may be experienced and displayed in augmented reality for the first person - with two augmented reality elements (the statue 1110 and the flying bumble bee avatar 2 of the second person) displayed in addition to actual physical elements around the local world in the scene, such as the ground, the buildings in the background, the statue platform 1120. Dynamic updating may be utilized to allow the first person to visualize progress of the second person's avatar 2 as the avatar 2 flies through the world local to the first person.

Again, with a configuration as described above, wherein there is one world model that can reside on cloud computing resources and be distributed from there, such world can be "passable" to one or more users in a relatively low bandwidth form preferable to trying to pass around realtime video data or the like. The augmented experience of the person standing near the statue (i.e., as shown in Figure 12) may be informed by the cloud-based world model, a subset of which may be passed down to them and their local display device to complete the view. A person sitting at a remote display device, which may be as simple as a personal computer sitting on a desk, can efficiently download that same section of information from the cloud and have it rendered on their display. Indeed, one person actually present in the park near the statue may take a remotely-located friend for a walk in that park, with the friend joining through virtual and augmented reality. The system will need to know where the street is, wherein the trees are, where the statue is - but with that information on the cloud, the joining friend can download from the cloud aspects of the scenario, and then start walking along as an augmented reality local relative to the person who is actually in the park.

Referring to Figure 13, a time and/or other contingency parameter based embodiment is depicted, wherein a person is engaged with a virtual and/or augmented reality interface, such as the user interface 302 or user display device featured in Figure 3, the display device 14 described below in reference to Figure 14, or variations thereof, is utilizing the system (4) and enters a coffee establishment to order a cup of coffee (6). The VRS may be configured to utilize sensing and data gathering capabilities, locally and/or remotely, to provide display enhancements in augmented and/or virtual reality for the person, such as highlighted locations of doors in the coffee establishment or bubble windows of the pertinent coffee menu (8). When the person receives the cup of coffee that he has ordered, or upon detection by the system of some other pertinent parameter, the system may be configured to display (10) one or more time-based augmented or virtual reality images, video, and/or sound in the local environment with the display device, such as a Madagascar jungle scene from the walls and ceilings, with or without jungle sounds and other effects, either static or dynamic. Such presentation to the user may be discontinued based upon a timing parameter (i.e., 5 minutes after the full coffee cup has been recognized and handed to the user; 10 minutes after the system has recognized the user walking through the front door of the establishment, etc) or other parameter, such as a recognition by the system that the user has finished the coffee by noting the upside down orientation of the coffee cup as the user ingests the last sip of coffee from the cup - or recognition by the system that the user has left the front door of the establishment (12).

Referring to Figure 14, one embodiment of a suitable user display device (14) is shown, comprising a display lens (82)

which may be mounted to a user's head or eyes by a housing or frame (84). The display lens (82) may comprise one or more transparent mirrors positioned by the housing (84) in front of the user's eyes (20) and configured to bounce projected light (38) into the eyes (20) and facilitate beam shaping, while also allowing for transmission of at least some light from the local environment in an augmented reality configuration (in a virtual reality configuration, it may be desirable for the display system 14 to be capable of blocking substantially all light from the local environment, such as by a darkened visor, blocking curtain, all black LCD panel mode, or the like). In the depicted embodiment, two wide-field-of-view machine vision cameras (16) are coupled to the housing (84) to image the environment around the user; in one embodiment these cameras (16) are dual capture visible light / infrared light cameras. The depicted embodiment also comprises a pair of scanned-laser shaped-wavefront (i.e., for depth) light projector modules with display mirrors and optics configured to project light (38) into the eyes (20) as shown. The depicted embodiment also comprises two miniature infrared cameras (24) paired with infrared light sources (26, such as light emitting diodes "LED"s), which are configured to be able to track the eyes (20) of the user to support rendering and user input. The system (14) further features a sensor assembly (39), which may comprise X, Y, and Z axis accelerometer capability as well as a magnetic compass and X, Y, and Z axis gyro capability, preferably providing data at a relatively high frequency, such as 200 Hz. The depicted system (14) also comprises a head pose processor (36), such as an ASIC (application specific integrated circuit), FPGA (field programmable gate array), and/or ARM processor (advanced reduced-instruction-set machine), which may be configured to

calculate real or near-real time user head pose from wide field of view image information output from the capture devices (16). Also shown is another processor (32) configured to execute digital and/or analog processing to derive pose from the gyro, compass, and/or accelerometer data from the sensor assembly (39). The depicted embodiment also features a GPS (37, global positioning satellite) subsystem to assist with pose and positioning. Finally, the depicted embodiment comprises a rendering engine (34) which may feature hardware running a software program configured to provide rendering information local to the user to facilitate operation of the scanners and imaging into the eyes of the user, for the user's view of the world. The rendering engine (34) is operatively coupled (81, 70, 76/78, 80; i.e., via wired or wireless connectivity) to the sensor pose processor (32), the image pose processor (36), the eye tracking cameras (24), and the projecting subsystem (18) such that light of rendered augmented and/or virtual reality objects is projected using a scanned laser arrangement (18) in a manner similar to a retinal scanning display. The wavefront of the projected light beam (38) may be bent or focused to coincide with a desired focal distance of the augmented and/or virtual reality object. The mini infrared cameras (24) may be utilized to track the eyes to support rendering and user input (i.e., where the user is looking, what depth he is focusing; as discussed below, eye verge may be utilized to estimate depth of focus). The GPS (37), gyros, compass, and accelerometers (39) may be utilized to provide course and/or fast pose estimates. The camera (16) images and pose, in conjunction with data from an associated cloud computing resource, may be utilized to map the local world and share user views with a virtual or augmented reality community. While much of the hardware in the display

system (14) featured in Figure 14 is depicted directly coupled to the housing (84) which is adjacent the display (82) and eyes (20) of the user, the hardware components depicted may be mounted to or housed within other components, such as a belt-mounted component, as shown, for example, in Figure 3. In one embodiment, all of the components of the system (14) featured in Figure 14 are directly coupled to the display housing (84) except for the image pose processor (36), sensor pose processor (32), and rendering engine (34), and communication between the latter three and the remaining components of the system (14) may be by wireless communication, such as ultra wideband, or wired communication. The depicted housing (84) preferably is head-mounted and wearable by the user. It may also feature speakers, such as those which may be inserted into the ears of a user and utilized to provide sound to the user which may be pertinent to an augmented or virtual reality experience such as the jungle sounds referred to in reference to Figure 13, and microphones, which may be utilized to capture sounds local to the user.

Regarding the projection of light (38) into the eyes (20) of the user, in one embodiment the mini cameras (24) may be utilized to measure where the centers of a user's eyes (20) are geometrically verged to, which, in general, coincides with a position of focus, or "depth of focus", of the eyes (20). A 3-dimensional surface of all points the eyes verge to is called the "horopter". The focal distance may take on a finite number of depths, or may be infinitely varying. Light projected from the vergence distance appears to be focused to the subject eye (20), while light in front of or behind the vergence distance is blurred. Further, it has been discovered that spatially coherent light with a beam diameter of less than about 0.7 millimeters is correctly resolved by the human eye regardless of

where the eye focuses; given this understanding, to create an illusion of proper focal depth, the eye vergence may be tracked with the mini cameras (24), and the rendering engine (34) and projection subsystem (18) may be utilized to render all objects on or close to the horopter in focus, and all other objects at varying degrees of defocus (i.e., using intentionally-created blurring). A see-through light guide optical element configured to project coherent light into the eye may be provided by suppliers such as Lumus, Inc. Preferably the system (14) renders to the user at a frame rate of about 60 frames per second or greater. As described above, preferably the mini cameras (24) may be utilized for eye tracking, and software may be configured to pick up not only vergence geometry but also focus location cues to serve as user inputs. Preferably such system is configured with brightness and contrast suitable for day or night use. In one embodiment such system preferably has latency of less than about 20 milliseconds for visual object alignment, less than about 0.1 degree of angular alignment, and about 1 arc minute of resolution, which is approximately the limit of the human eye. The display system (14) may be integrated with a localization system, which may involve the GPS element, optical tracking, compass, accelerometer, and/or other data sources, to assist with position and pose determination; localization information may be utilized to facilitate accurate rendering in the user's view of the pertinent world (i.e., such information would facilitate the glasses to know where they are with respect to the real world).

Other suitable display device include but are not limited to desktop and mobile computers, smartphones, smartphones which may be enhanced additional with software and hardware features to facilitate or simulate 3-D perspective viewing (for example,

in one embodiment a frame may be removably coupled to a smartphone, the frame featuring a 200 Hz gyro and accelerometer sensor subset, two small machine vision cameras with wide field of view lenses, and an ARM processor - to simulate some of the functionality of the configuration featured in Figure 14), tablet computers, tablet computers which may be enhanced as described above for smartphones, tablet computers enhanced with additional processing and sensing hardware, head-mounted systems that use smartphones and/or tablets to display augmented and virtual viewpoints (visual accommodation via magnifying optics, mirrors, contact lenses, or light structuring elements), non-see-through displays of light emitting elements (LCDs, OLEDs, vertical-cavity-surface-emitting lasers, steered laser beams, etc), see-through displays that simultaneously allow humans to see the natural world and artificially generated images (for example, light-guide optical elements, transparent and polarized OLEDs shining into close-focus contact lenses, steered laser beams, etc), contact lenses with light-emitting elements (such as those available from Innovega, Inc, of Bellevue, WA, under the tradename Ioptik RTM; they may be combined with specialized complimentary eyeglasses components), implantable devices with light-emitting elements, and implantable devices that stimulate the optical receptors of the human brain.

With a system such as that depicted in Figures 3 and 14, 3-D points may be captured from the environment, and the pose (i.e., vector and/or origin position information relative to the world) of the cameras that capture those images or points may be determined, so that these points or images may be "tagged", or associated, with this pose information. Then points captured by a second camera may be utilized to determine the pose of the second camera. In other words, one can orient and/or localize a

second camera based upon comparisons with tagged images from a first camera. Then this knowledge may be utilized to extract textures, make maps, and create a virtual copy of the real world (because then there are two cameras around that are registered). So at the base level, in one embodiment you have a person-worn system that can be utilized to capture both 3-D points and the 2-D images that produced the points, and these points and images may be sent out to a cloud storage and processing resource. They may also be cached locally with embedded pose information (i.e., cache the tagged images); so the cloud may have on the ready (i.e., in available cache) tagged 2-D images (i.e., tagged with a 3-D pose), along with 3-D points. If a user is observing something dynamic, he may also send additional information up to the cloud pertinent to the motion (for example, if looking at another person's face, the user can take a texture map of the face and push that up at an optimized frequency even though the surrounding world is otherwise basically static).

The cloud system may be configured to save some points as fiducials for pose only, to reduce overall pose tracking calculation. Generally it may be desirable to have some outline features to be able to track major items in a user's environment, such as walls, a table, etc, as the user moves around the room, and the user may want to be able to "share" the world and have some other user walk into that room and also see those points. Such useful and key points may be termed "fiducials" because they are fairly useful as anchoring points - they are related to features that may be recognized with machine vision, and that can be extracted from the world consistently and repeatedly on different pieces of user hardware. Thus these fiducials preferably may be saved to the cloud for further use.

In one embodiment it is preferable to have a relatively even distribution of fiducials throughout the pertinent world, because they are the kinds of items that cameras can easily use to recognize a location.

In one embodiment, the pertinent cloud computing configuration may be configured to groom the database of 3-D points and any associated meta data periodically to use the best data from various users for both fiducial refinement and world creation. In other words, the system may be configured to get the best dataset by using inputs from various users looking and functioning within the pertinent world. In one embodiment the database is intrinsically fractal - as users move closer to objects, the cloud passes higher resolution information to such users. As a user maps an object more closely, that data is sent to the cloud, and the cloud can add new 3-D points and image-based texture maps to the database if they are better than what has been previously stored in the database. All of this may be configured to happen from many users simultaneously.

As described above, an augmented or virtual reality experience may be based upon recognizing certain types of objects. For example, it may be important to understand that a particular object has a depth in order to recognize and understand such object. Recognizer software objects ("recognizers") may be deployed on cloud or local resources to specifically assist with recognition of various objects on either or both platforms as a user is navigating data in a world. For example, if a system has data for a world model comprising 3-D point clouds and pose-tagged images, and there is a desk with a bunch of points on it as well as an image of the desk, there may not be a determination that what is being observed is, indeed, a desk as humans would know it. In other

words, some 3-D points in space and an image from someplace off in space that shows most of the desk may not be enough to instantly recognize that a desk is being observed. To assist with this identification, a specific object recognizer may be created that will go into the raw 3-D point cloud, segment out a set of points, and, for example, extract the plane of the top surface of the desk. Similarly, a recognizer may be created to segment out a wall from 3-D points, so that a user could change wallpaper or remove part of the wall in virtual or augmented reality and have a portal to another room that is not actually there in the real world. Such recognizers operate within the data of a world model and may be thought of as software "robots" that crawl a world model and imbue that world model with semantic information, or an ontology about what is believed to exist amongst the points in space. Such recognizers or software robots may be configured such that their entire existence is about going around the pertinent world of data and finding things that it believes are walls, or chairs, or other items. They may be configured to tag a set of points with the functional equivalent of, "this set of points belongs to a wall", and may comprise a combination of point-based algorithm and pose-tagged image analysis for mutually informing the system regarding what is in the points.

Object recognizers may be created for many purposes of varied utility, depending upon the perspective. For example, in one embodiment, a purveyor of coffee such as Starbucks may invest in creating an accurate recognizer of Starbucks coffee cups within pertinent worlds of data. Such a recognizer may be configured to crawl worlds of data large and small searching for Starbucks coffee cups, so they may be segmented out and identified to a user when operating in the pertinent nearby

space (i.e., perhaps to offer the user a coffee in the Starbucks outlet right around the corner when the user looks at his Starbucks cup for a certain period of time). With the cup segmented out, it may be recognized quickly when the user moves it on his desk. Such recognizers may be configured to run or operate not only on cloud computing resources and data, but also on local resources and data, or both cloud and local, depending upon computational resources available. In one embodiment, there is a global copy of the world model on the cloud with millions of users contributing to that global model, but for smaller worlds or sub-worlds like an office of a particular individual in a particular town, most of the global world will not care what that office looks like, so the system may be configured to groom data and move to local cache information that is believed to be most locally pertinent to a given user. In one embodiment, for example, when a user walks up to a desk, related information (such as the segmentation of a particular cup on his table) may be configured to reside only upon his local computing resources and not on the cloud, because objects that are identified as ones that move often, such as cups on tables, need not burden the cloud model and transmission burden between the cloud and local resources. Thus the cloud computing resource may be configured to segment 3-D points and images, thus factoring permanent (i.e., generally not moving) objects from movable ones, and this may affect where the associated data is to remain, where it is to be processed, remove processing burden from the wearable/local system for certain data that is pertinent to more permanent objects, allow one-time processing of a location which then may be shared with limitless other users, allow multiple sources of data to simultaneously build a databased of fixed and movable objects in a particular physical

location, and segment objects from the background to create object-specific fiducials and texture maps.

In one embodiment, the system may be configured to query a user for input about the identity of certain objects (for example, the system may present the user with a question such as, "is that a Starbucks coffee cup?"), so that the user may train the system and allow the system to associate semantic information with objects in the real world. An ontology may provide guidance regarding what objects segmented from the world can do, how they behave, etc. In one embodiment the system may feature a virtual or actual keypad, such as a wirelessly connected keypad, connectivity to a keypad of a smartphone, or the like, to facilitate certain user input to the system.

The system may be configured to share basic elements (walls, windows, desk geometry, etc) with any user who walks into the room in virtual or augmented reality, and in one embodiment that person's system will be configured to take images from his particular perspective and upload those to the cloud. Then the cloud becomes populated with old and new sets of data and can run optimization routines and establish fiducials that exist on individual objects.

GPS and other localization information may be utilized as inputs to such processing. Further, other computing systems and data, such as one's online calendar or FaceBook account information, may be utilized as inputs (for example, in one embodiment, a cloud and/or local system may be configured to analyze the content of a user's calendar for airline tickets, dates, and destinations, so that over time, information may be moved from the cloud to the user's local systems to be ready for the user's arrival time in a given destination).

In one embodiment, tags such as QR codes and the like may be inserted into a world for use with non-statistical pose calculation, security/access control, communication of special information, spatial messaging, non-statistical object recognition, etc.

In one embodiment, cloud resources may be configured to pass digital models of real and virtual worlds between users, as described above in reference to "passable worlds", with the models being rendered by the individual users based upon parameters and textures. This reduces bandwidth relative to the passage of realtime video, allows rendering of virtual viewpoints of a scene, and allows millions or more users to participate in one virtual gathering without sending each of them data that they need to see (such as video), because their views are rendered by their local computing resources.

The virtual reality system ("VRS") may be configured to register the user location and field of view (together known as the "pose") through one or more of the following: realtime metric computer vision using the cameras, simultaneous localization and mapping techniques, maps, and data from sensors such as gyros, accelerometers, compass, barometer, GPS, radio signal strength triangulation, signal time of flight analysis, LIDAR ranging, RADAR ranging, odometry, and sonar ranging. The wearable device system may be configured to simultaneously map and orient. For example, in unknown environments, the VRS may be configured to collect information about the environment, ascertaining fiducial points suitable for user pose calculations, other points for world modeling, images for providing texture maps of the world. Fiducial points may be used to optically calculate pose. As the world is mapped with greater detail, more objects may be segmented out and given

their own texture maps, but the world still preferably is representable at low spatial resolution in simple polygons with low resolution texture maps. Other sensors, such as those discussed above, may be utilized to support this modeling effort. The world may be intrinsically fractal in that moving or otherwise seeking a better view (through viewpoints, "supervision" modes, zooming, etc) request high-resolution information from the cloud resources. Moving closer to objects captures higher resolution data, and this may be sent to the cloud, which may calculate and/or insert the new data at interstitial sites in the world model.

Referring to Figure 16, a wearable system may be configured to capture image information and extract fiducials and recognized points (52). The wearable local system may calculate pose using one of the pose calculation techniques mentioned below. The cloud (54) may be configured to use images and fiducials to segment 3-D objects from more static 3-D background; images provide textures maps for objects and the world (textures may be realtime videos). The cloud resources (56) may be configured to store and make available static fiducials and textures for world registration. The cloud resources may be configured to groom the point cloud for optimal point density for registration. The cloud resources (60) may store and make available object fiducials and textures for object registration and manipulation; the cloud may groom point clouds for optimal density for registration. The cloud resource may be configured (62) to use all valid points and textures to generate fractal solid models of objects; the cloud may groom point cloud information for optimal fiducial density. The cloud resource (64) may be configured to query users for training on identity of segmented objects and the world; an

ontology database may use the answers to imbue objects and the world with actionable properties.

The following specific modes of registration and mapping feature the terms "O-pose", which represents pose determined from the optical or camera system; "s-pose", which represents pose determined from the sensors (i.e., such as a combination of GPS, gyro, compass, accelerometer, etc data, as discussed above); and "MLC", which represents the cloud computing and data management resource.

1. Orient: make a basic map of a new environment

Purpose: establish pose if environment is not mapped or (the equivalent) if not connected to the MLC.

- Extract points from image, track from frame to frame, triangulate fiducials using S-pose.
- Uses S-pose because there are no fiducials
- Filter out bad fiducials based on persistence.
- This is the most basic mode: it will always work for low-precision pose. With a little time and some relative motion it will establish a minimum fiducial set for O-pose and/or mapping.
- Jump out of this mode as soon as O-pose is reliable.

2. Map and O-Pose: map an environment

Purpose: establish high-precision pose, map the environment, and provide the map (with images) to the MLC.

- Calculate O-pose from mature world fiducials. Use S-pose as check of O-pose solution and to speed computation (O-pose is a non-linear gradient search).
- Mature fiducials may come from MLC, or be those locally determined.

- Extract points from image, track from frame to frame, triangulate fiducials using O-pose.
- Filter out bad fiducials based on persistence.
- Provide MLC with fiducials and pose-tagged images.
- Last three steps need not happen real-time.

3. O-Pose: determine pose

Purpose: establish high-precision pose in an already mapped environment using minimum processing power.

- Use historic S- and O-pose (n-1, n-2, n-3, etc.) to estimate pose at n.
- Use pose at n to project fiducials into image captured at n, then create image mask from the projection.
- Extract points from the masked regions (processing burden greatly reduced by only searching/extracting points from the masked subsets of image).
- Calculate O-pose from extracted points and mature world fiducials.
- Use S- and O-pose at n to estimate pose at n+1.
- Option: provide pose-tagged images/video to MLC cloud.

4. Super Res: determine super resolution imagery and fiducials

Purpose: create super-resolution imagery and fiducials.

- Composite pose-tagged images to create super-resolution images.
- Use super-resolution images to enhance fiducial position estimation.

- Iterate O-pose estimates from super resolution fiducials and imagery.
- Option: Loop the above steps on a wearable device (in real time) or the MLC (for better world).

In one embodiment, the VLS system may be configured to have certain base functionality, as well as functionality facilitated by "apps" or applications that may be distributed through the VLS to provide certain specialized functionalities. For example, the following apps may be installed to the subject VLS to provide specialized functionality:

Painterly renderings app. Artists create image transforms that represent the world they see it. Users enable these transforms, thus viewing the world "through" the artists eyes.

Table top modeling app. Users "build" objects from physical objects put on a table.

Virtual presence app. Users pass virtual model of space to other user, who then moves around space using virtual avatar.

Avatar emotion app. Measurements of subtle voice inflection, minor head movement, body temperature, heart rate, etc. animate subtle effects on virtual-presence avatars. Digitizing human state information and passing that to remote avatar uses less bandwidth than video. Additionally, such data is map-able to non-human avatars capable of emotion. Ex. A dog avatar can show excitement by wagging its tail based on excited vocal inflections.

An efficient mesh type network may be desirable for moving data, as opposed to sending everything back to a server. Many mesh networks, however, have suboptimal performance because positional information and topology is not well characterized. In one embodiment, the system may be utilized to determine the

location of all users with relatively high precision, and thus a mesh network configuration may be utilized for high performance.

In one embodiment the system may be utilized for searching. With augmented reality, for example, users will generate and leave content related to many aspects of the physical world. Much of this content is not text, and thus is not easily searched by typical methods. The system may be configured to provide a facility for keeping track of personal and social network content for searching and reference purposes.

In one embodiment, if the display device tracks 2-D points through successive frames, then fits a vector-valued function to the time evolution of those points, it is possible to sample the vector valued function at any point in time (e.g. between frames) or at some point in the near future (by projecting the vector-valued function forward in time. This allows creation of high-resolution post-processing, and prediction of future pose before the next image is actual captured (e.g., doubling the registration speed is possible without doubling the camera frame rate).

For body-fixed rendering (as opposed to head-fixed or world-fixed renderings) an accurate view of body is desired. Rather than measuring the body, in one embodiment is possible to derive its location through the average position of a users head. If the user's face points forward most of the time, a multi-day average of head position will reveal that direction. In conjunction with the gravity vector, this provides a reasonably stable coordinate frame for body-fixed rendering. Using current measures of head position with respect to this long-duration coordinate frame allows consistent rendering of objects on/around a users body - with no extra instrumentation. For implementation of this embodiment, single register averages

of head direction-vector may be started, and a running sum of data divided by Δt will give current average head position. Keeping five or so registers, started on day $n-5$, day $n-4$, day $n-3$, day $n-2$, day $n-1$ allows use of rolling averages of only the past "n" days.

In one embodiment, a scene may be scaled down and presented to a user in a smaller-than-actual space. For example, in a situation wherein there is a scene that must be rendered in a huge space (i.e., such as a soccer stadium), there may be no equivalent huge space present, or such a large space may be inconvenient to a user. In one embodiment the system may be configured to reduce the scale of the scene, so that the user may watch it in miniature. For example, one could have a gods-eye-view video game, or a world championship soccer game, play out in an unscaled field - or scaled down and presented on a living room floor. The system may be configured to simply shift the rendering perspective, scale, and associated accommodation distance.

The system may also be configured to draw a user's attention to specific items within a presented scene by manipulating focus of virtual or augmented reality objects, by highlighting them, changing the contrast, brightness, scale, etc.

Preferably the system may be configured to accomplish the following modes:

Open space rendering:

- Grab key points from structured environment, then fill in the space between with ML renderings.
- Potential venues: stages, output spaces, large indoor spaces (stadiums).

Object wrapping:

- Recognize 3D object in the real world, then augment them
- "Recognition" here means identifying a 3D blob with high enough precision to anchor imagery to.
- There are two types of recognition: 1) Classifying the type of an object (ex. a "face"); 2) Classifying a particular instance of an object (ex. Joe, a person).
- Build recognizers software objects for various things: walls, ceilings, floors, faces, roads, sky, skyscrapers, ranch houses, tables, chairs, cars, road signs, billboards, doors, windows, bookshelves, etc
- Some recognizers are Type I, and have generic functionality, e.g. "put my video on that wall", "that is a dog"
- Other recognizers are Type II, and have specific functionality, e.g. "my TV is on my living room wall 3.2 feet from the ceiling", "that is Fido" (this is a more capable version of the generic recognizer)
- Building recognizer as software objects allows metered release of functionality, and finer grained control of experience

Body centered rendering

- Render virtual objects fixed to the users body.
- Some things should float around the user's body, like a digital toolbelt.
- This requires knowing where the body is, rather than just the head. May get body position reasonably accurate by having a long-term average of users head

position (heads usually point forward parallel to the ground).

- A trivial case is objects floating around the head.

Transparency/cutaway

- For Type II recognized objects, show cut-aways
- Link Type II recognized objects to an online database of 3D models.
- Should start with objects that have commonly available 3D models, such as cars and public utilities.

Virtual presence

- Paint remote people's avatars into open spaces.
 - A subset of "open space rendering" (above).
 - Users create rough geometry of local environment and iteratively send both geometry and texture maps to others.
 - Users must grant permission for others to enter their environment.
 - Subtle voice queues, hand tracking, and head motion are sent to remote avatar. Avatar is animated from these fuzzy inputs.
 - The above minimize bandwidth.
- Make a wall a "portal" to another room
 - As with other method, pass geometry and texture map.
 - Instead of showing avatar in local room, designate recognized object (e.g. a wall) as a portal to the other's environment. In this way multiple people could sit in their own rooms, looking "through" walls into the environments of others.

Virtual viewpoints

- Dense digital model of area is created when a group of cameras (people) view a scene from different perspectives. This rich digital model is renderable from any vantage point that at least one camera can see.
- Example. People at a wedding. Scene is jointly modeled by all attendees. Recognizers differentiate and texture map stationary objects differently than moving ones (e.g. walls have stable texture map, people have higher frequency moving texture maps.)
- With rich digital model updated in real time, scene is renderable from any perspective. Attendee in back can fly in the air to the front row for a better view.
- Attendees can show their moving avatar, or have their perspective hidden.
- Off-site attendees can find a "seat" either with their avatar or if the organizers permit, invisibly.
- Likely requires extremely high bandwidth. Notionally, high frequency data is steamed through the crowd on a high-speed local wireless. Low frequency data comes from the MLC.
- Because all attendees have high precision position information, making an optimal routing path for local networking is trivial.

Messaging

- Simple silent messaging may be desirable
- For this and other applications, it may be desirable to have a finger chording keyboard.

- Tactile glove solutions may offer enhanced performance.

Full Virtual Reality (VR):

- With vision system darkened, show a view not overlaying on the real world.
- Registration system is still necessary to track head position.
- "Couch mode" allows user to fly.
- "Walking mode" re-renders objects in the real world as virtual ones so user does not collide with real world.
- Rendering body parts is essential for suspension of disbelief. This implies having method for tracking and rendering body parts in FOV.
- Non-see through visor is a form of VR with many image enhancement advantages not possible with direct overlay
- Wide FOV, perhaps even the ability to look to rear
- Various forms of "super vision": telescope, see through, infrared, God's eye, etc.

In one embodiment a system for virtual and/or augmented user experience is configured such that remote avatars associated with users may be animated based at least in part upon data on a wearable device with input from sources such as voice inflection analysis and facial recognition analysis, as conducted by pertinent software modules. For example, referring back to Figure 12, the bee avatar (2) may be animated to have a friendly smile based upon facial recognition of a smile upon the user's face, or based upon a friendly tone of voice or speaking, as determined by software configured to analyze voice inputs to

microphones which may capture voice samples locally from the user. Further, the avatar character may be animated in a manner in which the avatar is likely to express a certain emotion. For example, in an embodiment wherein the avatar is a dog, a happy smile or tone detected by system local to the human user may be expressed in the avatar as a wagging tail of the dog avatar.

Various exemplary embodiments of the invention are described herein. Reference is made to these examples in a non-limiting sense. They are provided to illustrate more broadly applicable aspects of the invention. Various changes may be made to the invention described and equivalents may be substituted without departing from the true spirit and scope of the invention. In addition, many modifications may be made to adapt a particular situation, material, composition of matter, process, process act(s) or step(s) to the objective(s), spirit or scope of the present invention. Further, as will be appreciated by those with skill in the art that each of the individual variations described and illustrated herein has discrete components and features which may be readily separated from or combined with the features of any of the other several embodiments without departing from the scope or spirit of the present inventions. All such modifications are intended to be within the scope of claims associated with this disclosure.

The invention includes methods that may be performed using the subject devices. The methods may comprise the act of providing such a suitable device. Such provision may be performed by the end user. In other words, the "providing" act merely requires the end user obtain, access, approach, position, set-up, activate, power-up or otherwise act to provide the requisite device in the subject method. Methods recited herein

may be carried out in any order of the recited events which is logically possible, as well as in the recited order of events.

Exemplary aspects of the invention, together with details regarding material selection and manufacture have been set forth above. As for other details of the present invention, these may be appreciated in connection with the above-referenced patents and publications as well as generally known or appreciated by those with skill in the art. The same may hold true with respect to method-based aspects of the invention in terms of additional acts as commonly or logically employed.

In addition, though the invention has been described in reference to several examples optionally incorporating various features, the invention is not to be limited to that which is described or indicated as contemplated with respect to each variation of the invention. Various changes may be made to the invention described and equivalents (whether recited herein or not included for the sake of some brevity) may be substituted without departing from the true spirit and scope of the invention. In addition, where a range of values is provided, it is understood that every intervening value, between the upper and lower limit of that range and any other stated or intervening value in that stated range, is encompassed within the invention.

Also, it is contemplated that any optional feature of the inventive variations described may be set forth and claimed independently, or in combination with any one or more of the features described herein. Reference to a singular item, includes the possibility that there are plural of the same items present. More specifically, as used herein and in claims associated hereto, the singular forms "a," "an," "said," and "the" include plural referents unless the specifically stated

2012348348 12 Nov 2015

otherwise. In other words, use of the articles allow for "at least one" of the subject item in the description above as well as claims associated with this disclosure. It is further noted that such claims may be drafted to exclude any optional
5 element. As such, this statement is intended to serve as antecedent basis for use of such exclusive terminology as "solely," "only" and the like in connection with the recitation of claim elements, or use of a "negative" limitation.

Without the use of such exclusive terminology, the term
10 "comprising" in claims associated with this disclosure shall allow for the inclusion of any additional element—irrespective of whether a given number of elements are enumerated in such claims, or the addition of a feature could be regarded as transforming the nature of an element set forth in such claims.
15 Except as specifically defined herein, all technical and scientific terms used herein are to be given as broad a commonly understood meaning as possible while maintaining claim validity.

The breadth of the present invention is not to be limited
20 to the examples provided and/or the subject specification, but rather only by the scope of claim language associated with this disclosure.

Throughout this specification and the claims which follow, unless the context requires otherwise, the word "comprise", and
25 variations such as "comprises" or "comprising", will be understood to imply the inclusion of a stated integer or step or group of integers or steps but not the exclusion of any other integer or step or group of integers or steps.

The reference in this specification to any prior
30 publication (or information derived from it), or to any matter which is known, is not, and should not be taken as, an acknowledgement or admission or any form of suggestion that that prior publication (or information derived from it) or known matter forms part of the common general knowledge in the
35 field of endeavour to which this specification relates.

2012348348 12 Nov 2015

The claims defining the invention are as follows:

1. A system for enabling two or more users to interact within a virtual world comprising virtual world data, comprising:

5 a computer network comprising one or more computing devices, the one or more computing devices comprising memory, processing circuitry, and software stored at least in part in the memory and executable by the processing circuitry to process at least a portion of the virtual world data; and

10 a user device having a wearable user display component, wherein the user device is operatively coupled to the computer network,

wherein at least a first portion of the virtual world data comprises a virtual object rendered from and representing a physical object local to a first user,

15 the computer network is operable to transmit the first portion of the virtual world data to the user device associated with a second user, and

20 the wearable user display component visually displays the virtual object to the second user, such that a virtual representation of the physical object local to the first user is visually presented to the second user at the second user's location.

25 2. The system of claim 1, wherein the first and second users are in different physical locations.

3. The system of claim 1, wherein the first and second users are in substantially the same physical location.

30

2012348348 12 Nov 2015

4. The system of claim 1, wherein at least a portion of the virtual world changes in response to a change in the virtual world data.

5 5. The system of claim 1, wherein at least a portion of the virtual world changes in response to a change in the physical object.

6. The system of claim 5, wherein the change in the portion
10 of the virtual world represents the virtual object having a predetermined relationship with the physical object.

7. The system of claim 6, wherein the change in the portion
15 of the virtual world is presented to the user device for presentation to the second user according to the predetermined relationship.

8. The system of claim 1, wherein the virtual world is
20 operable to be rendered by at least one of a computer server or a user device.

9. The system of claim 1, wherein the virtual world is presented in a two-dimensional format.

25 10. The system of claim 1, wherein the virtual world is presented in a three-dimensional format.

11. The system of claim 1, wherein the user device is operable
30 to provide an interface for enabling interaction between a user and the virtual world in an augmented reality mode.

2012348348 12 Nov 2015

12. The system of claim 1, wherein the user device is operable to provide an interface for enabling interaction between a user and the virtual world in a virtual reality mode.

5 13. The system of claim 1, wherein the user device is operable to provide an interface for enabling interaction between a user and the virtual world in a combination of augmented and virtual reality mode.

10 14. The system of claim 1, wherein the virtual world data is transmitted over a data network.

15 15. The system of claim 1, wherein the computer network is operable to receive at least a portion of the virtual world data from a user device.

20 16. The system of claim 1, wherein at least a portion of the virtual world data is transmitted to the user device and comprises instructions for generating at least a portion of the virtual world.

25 17. The system of claim 1, wherein at least a portion of the virtual world data is transmitted to a gateway for at least one of processing or distribution.

18. The system of claim 17, wherein at least one of the one or more computing devices are operable to process virtual world data distributed by the gateway.

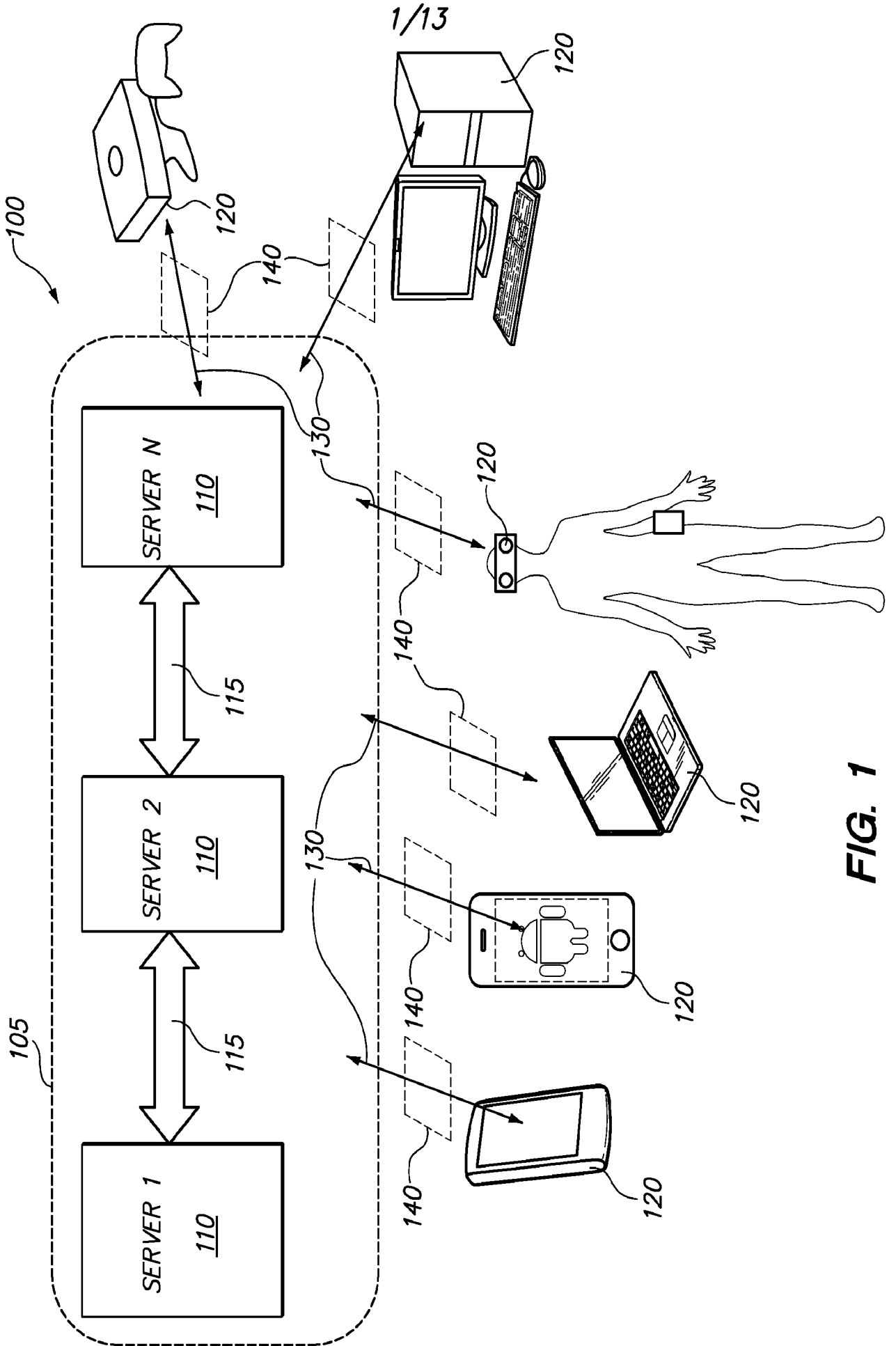

FIG. 1

2/13

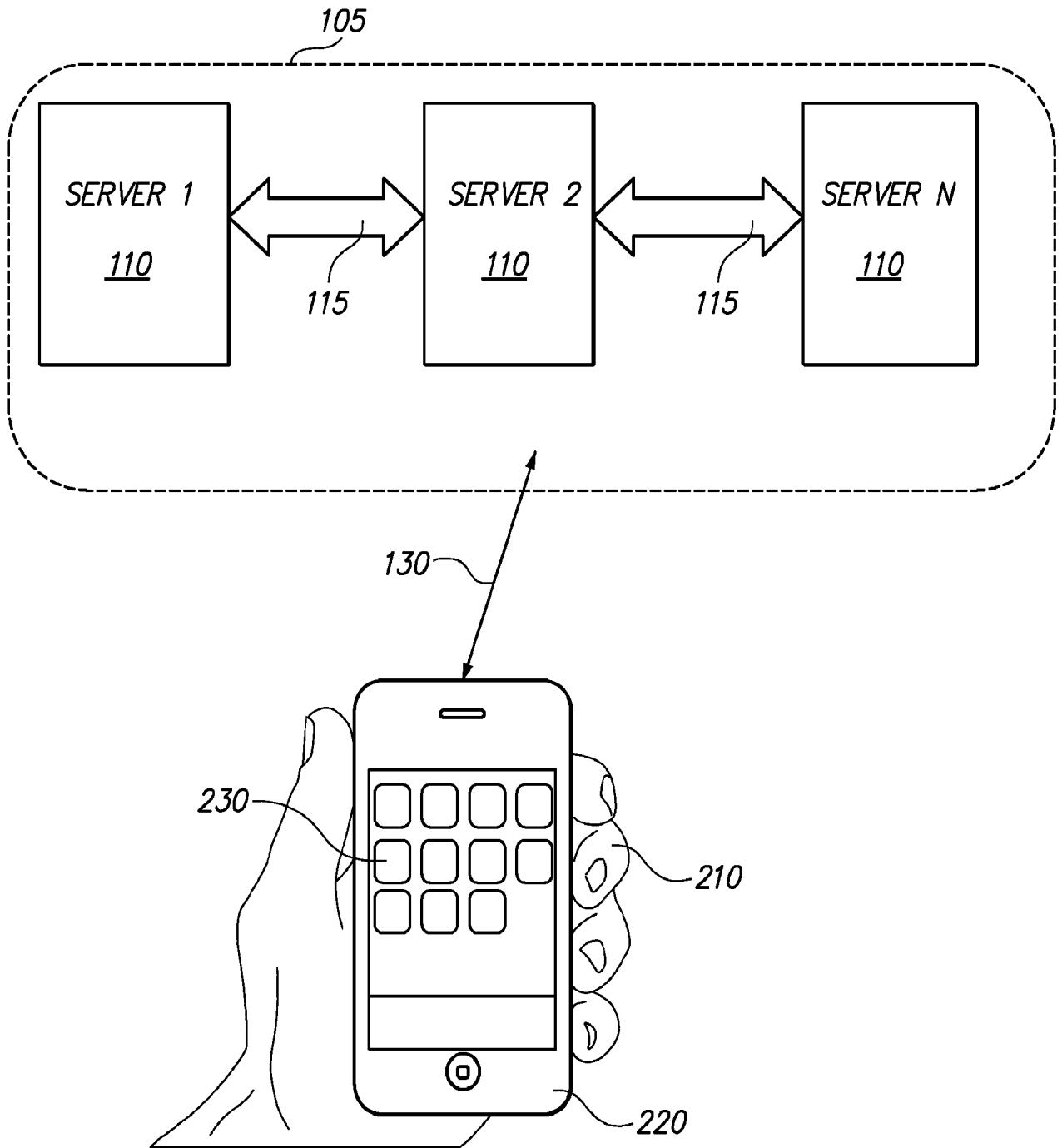

FIG. 2

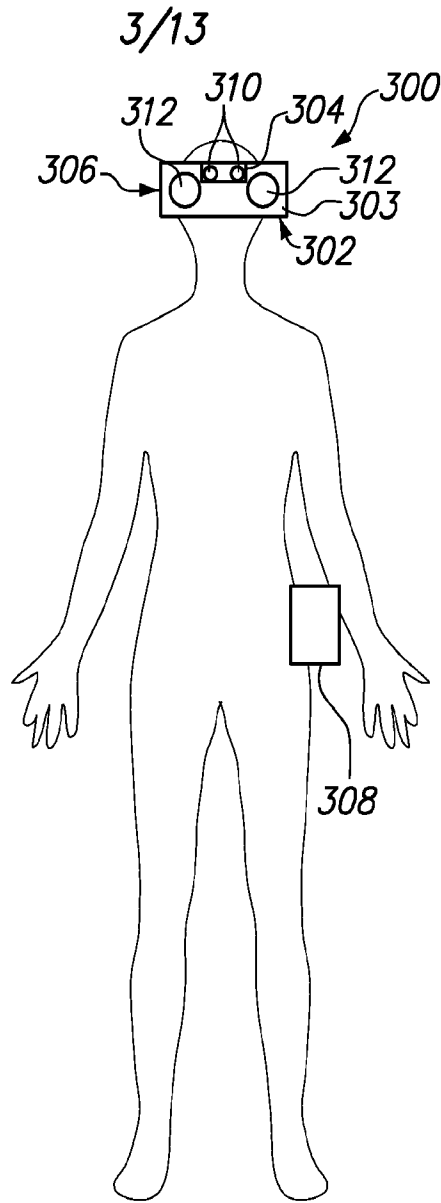

FIG. 3

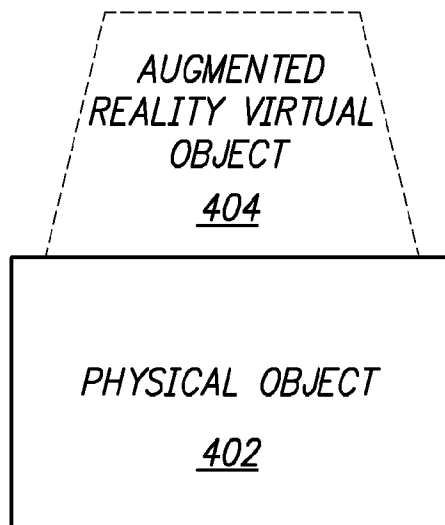

FIG. 4

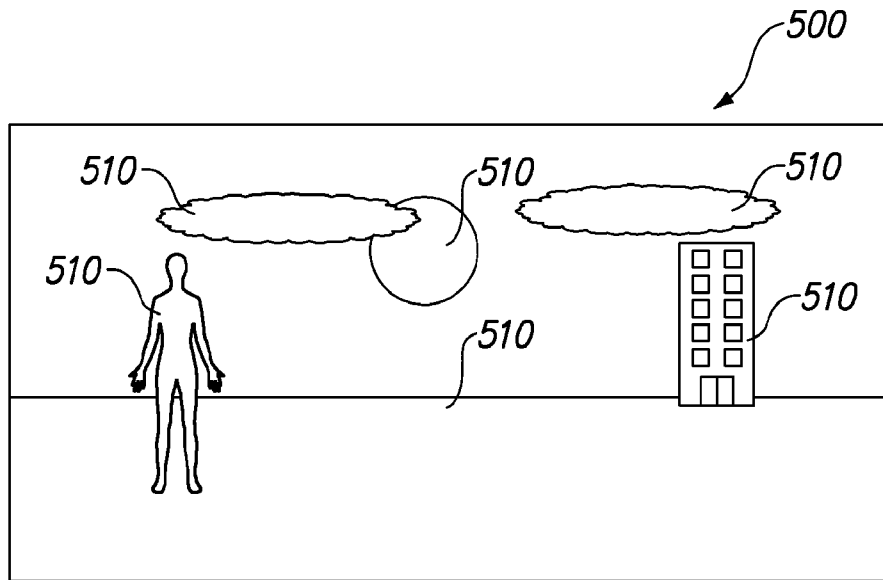

FIG. 5

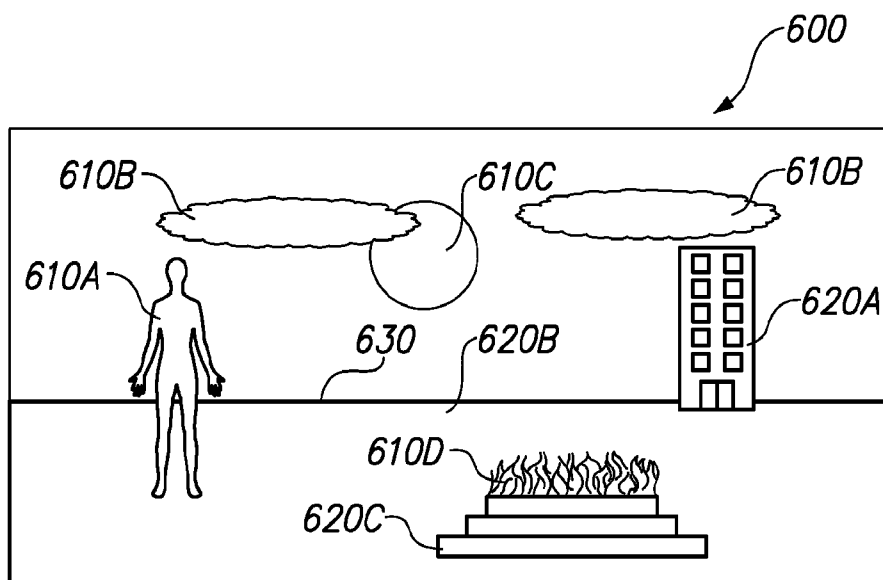

FIG. 6

5/13

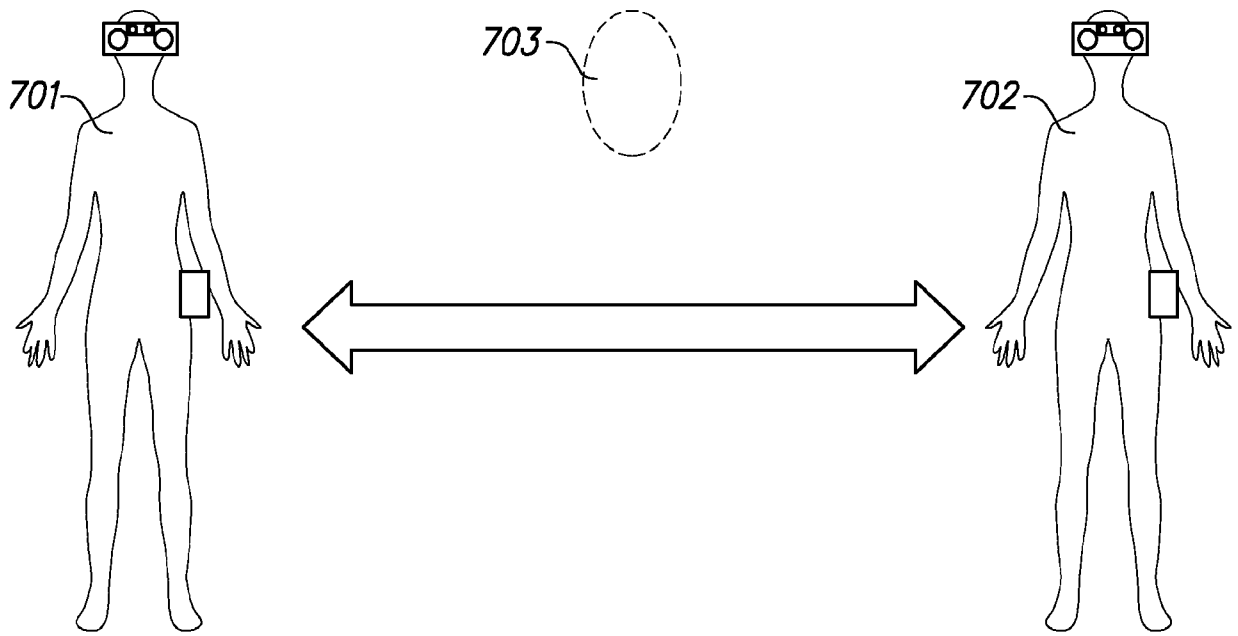

FIG. 7

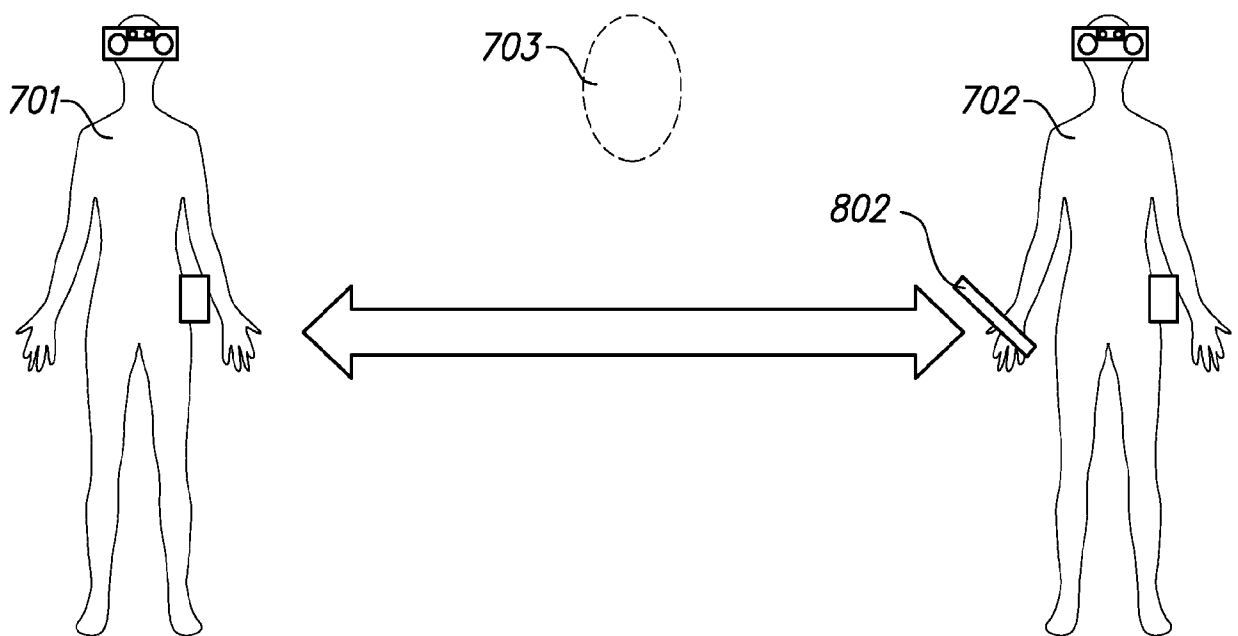

FIG. 8

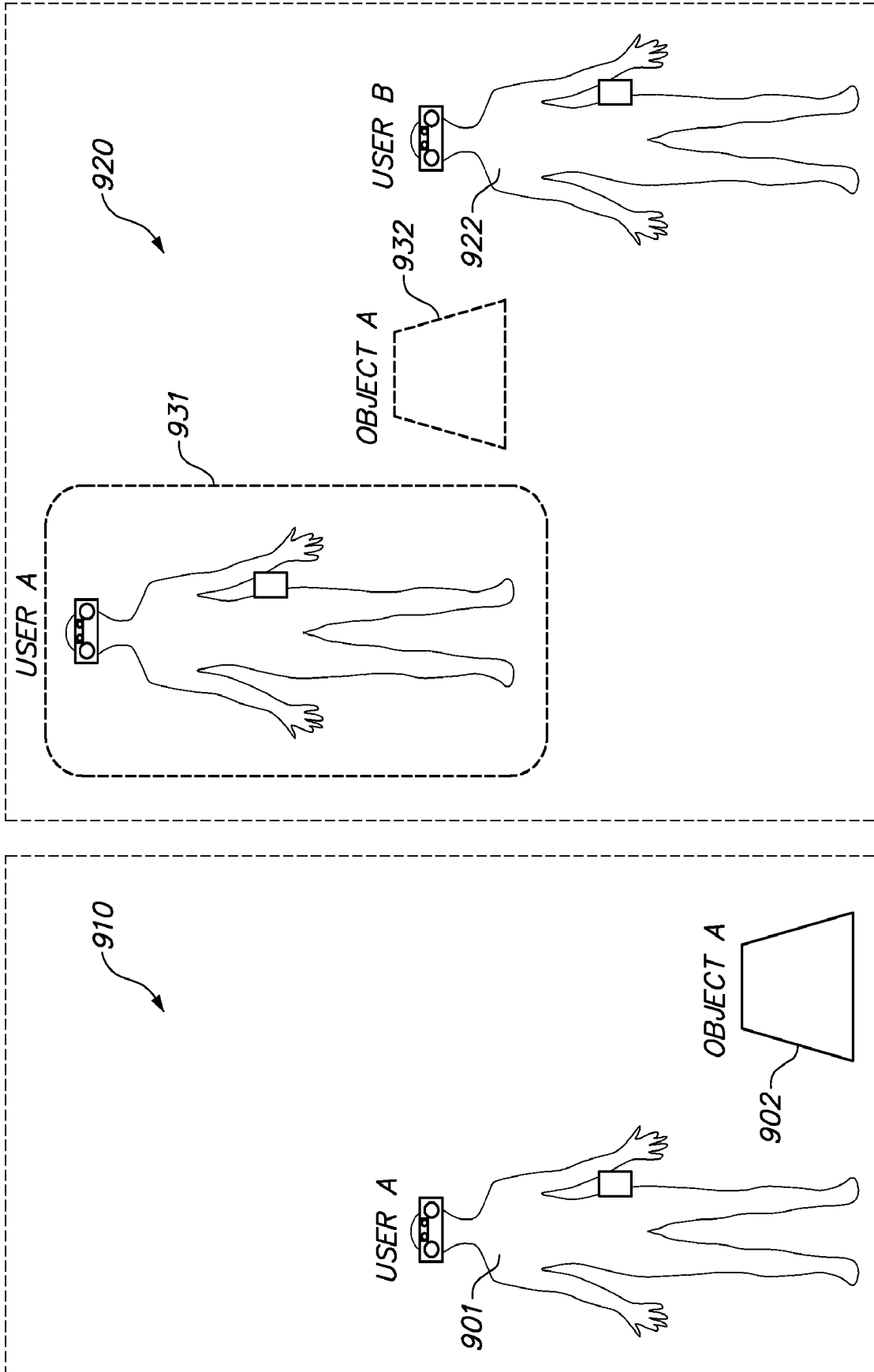

FIG. 9A

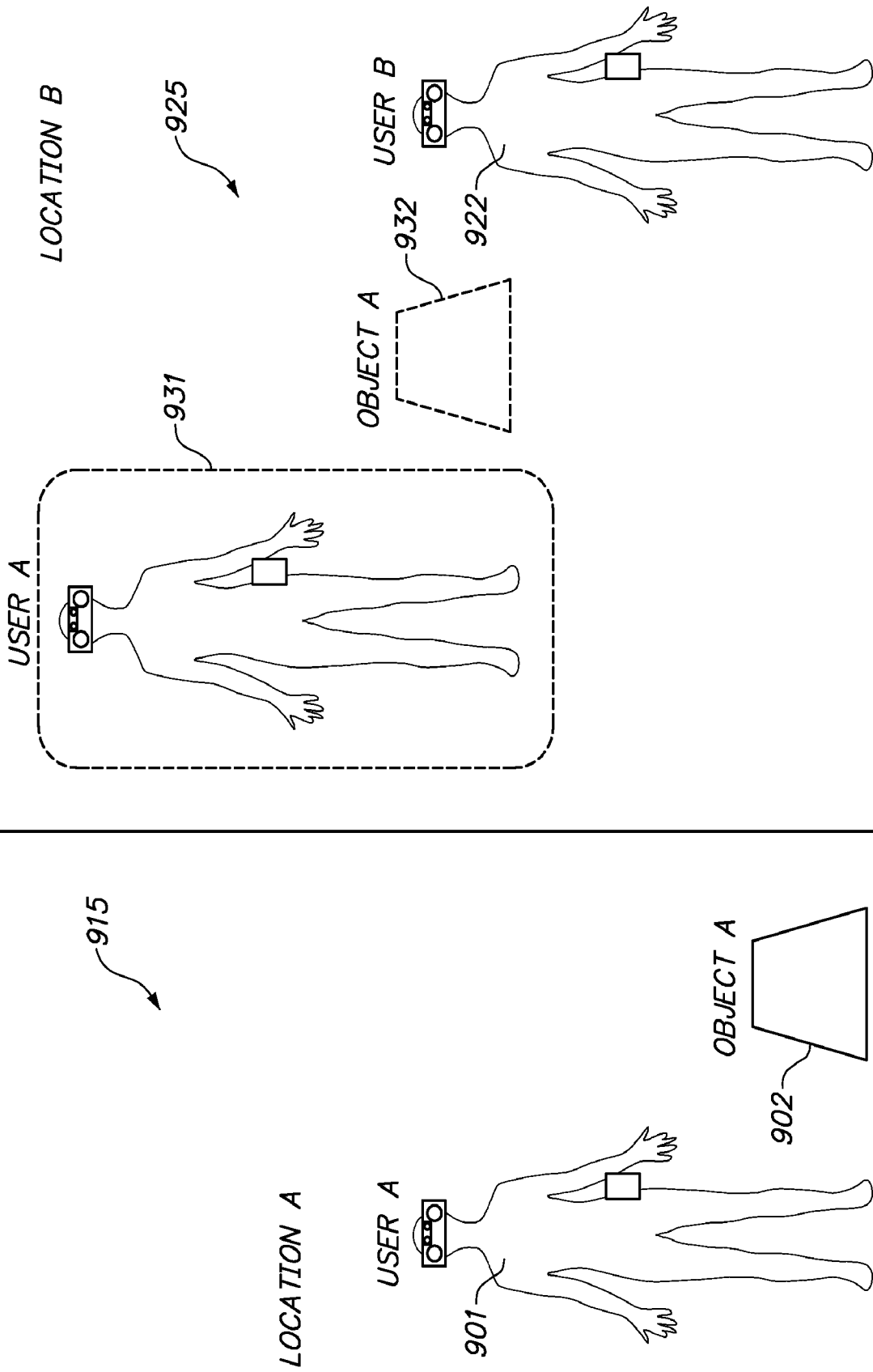

FIG. 9B

8/13

1010

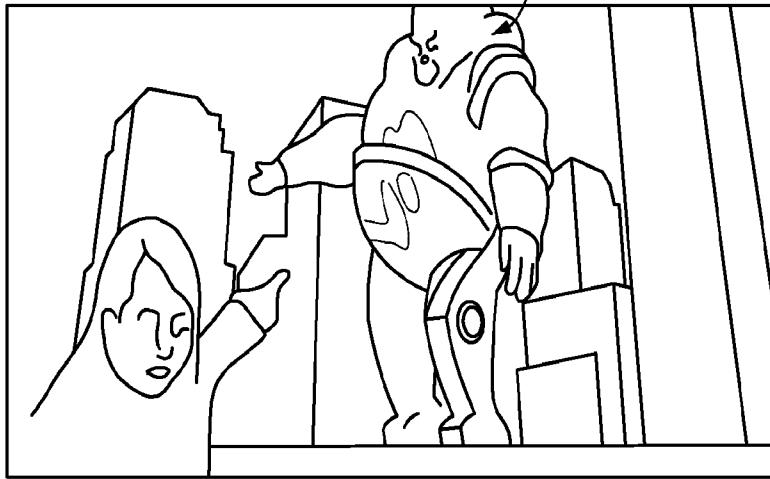

FIG. 10

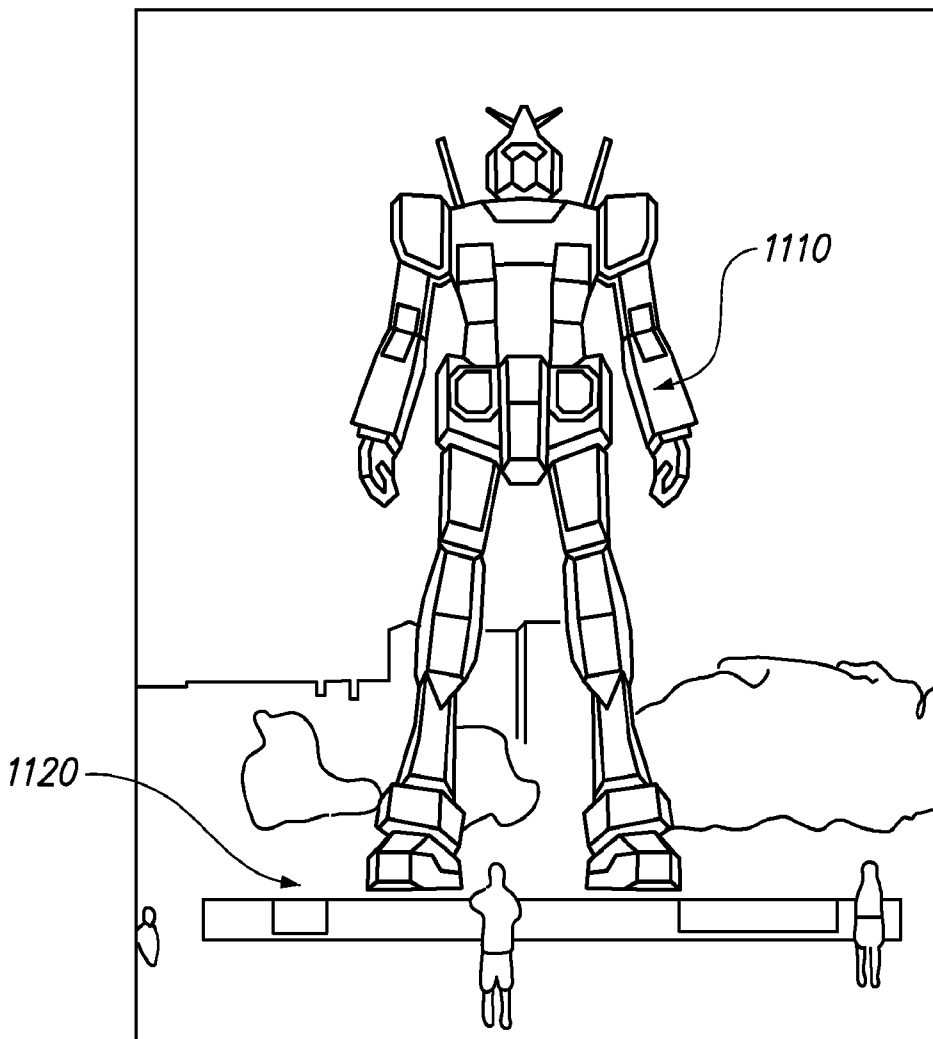

FIG. 11

9/13

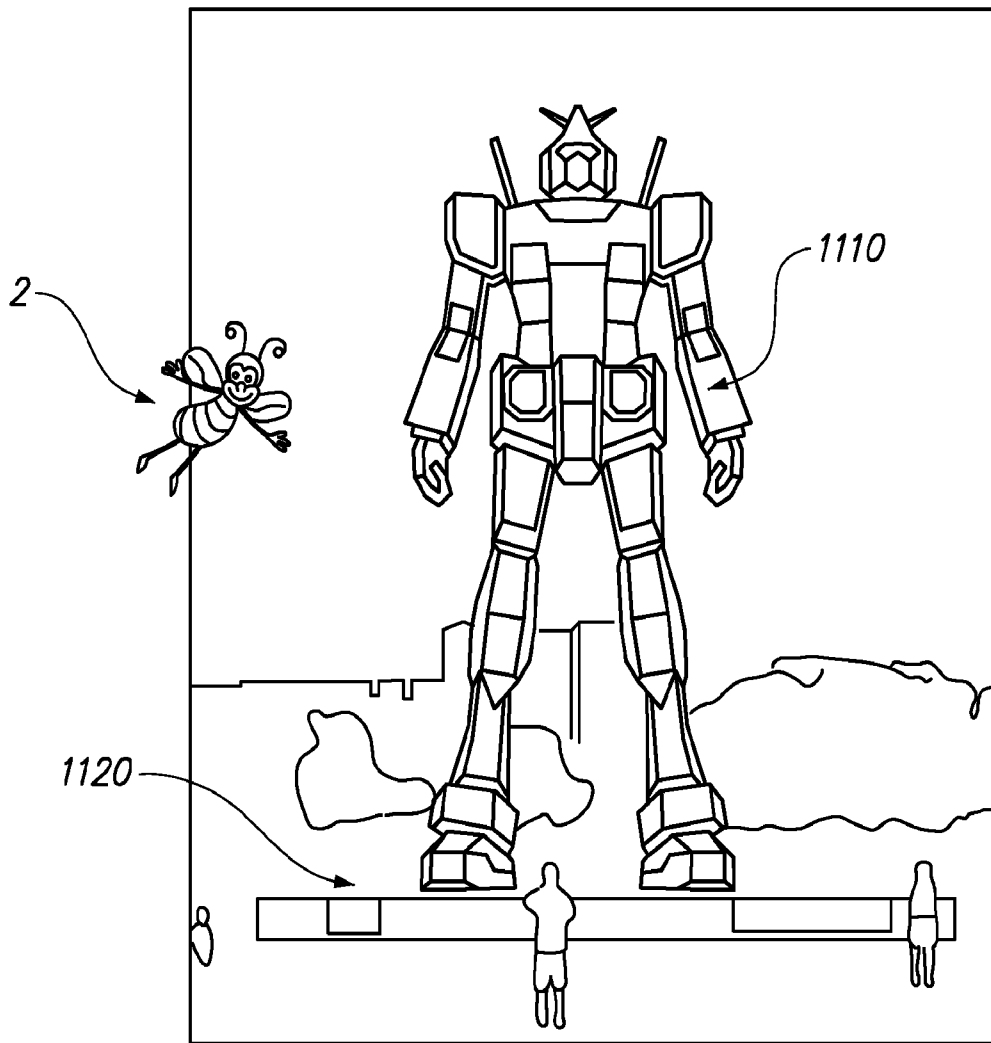
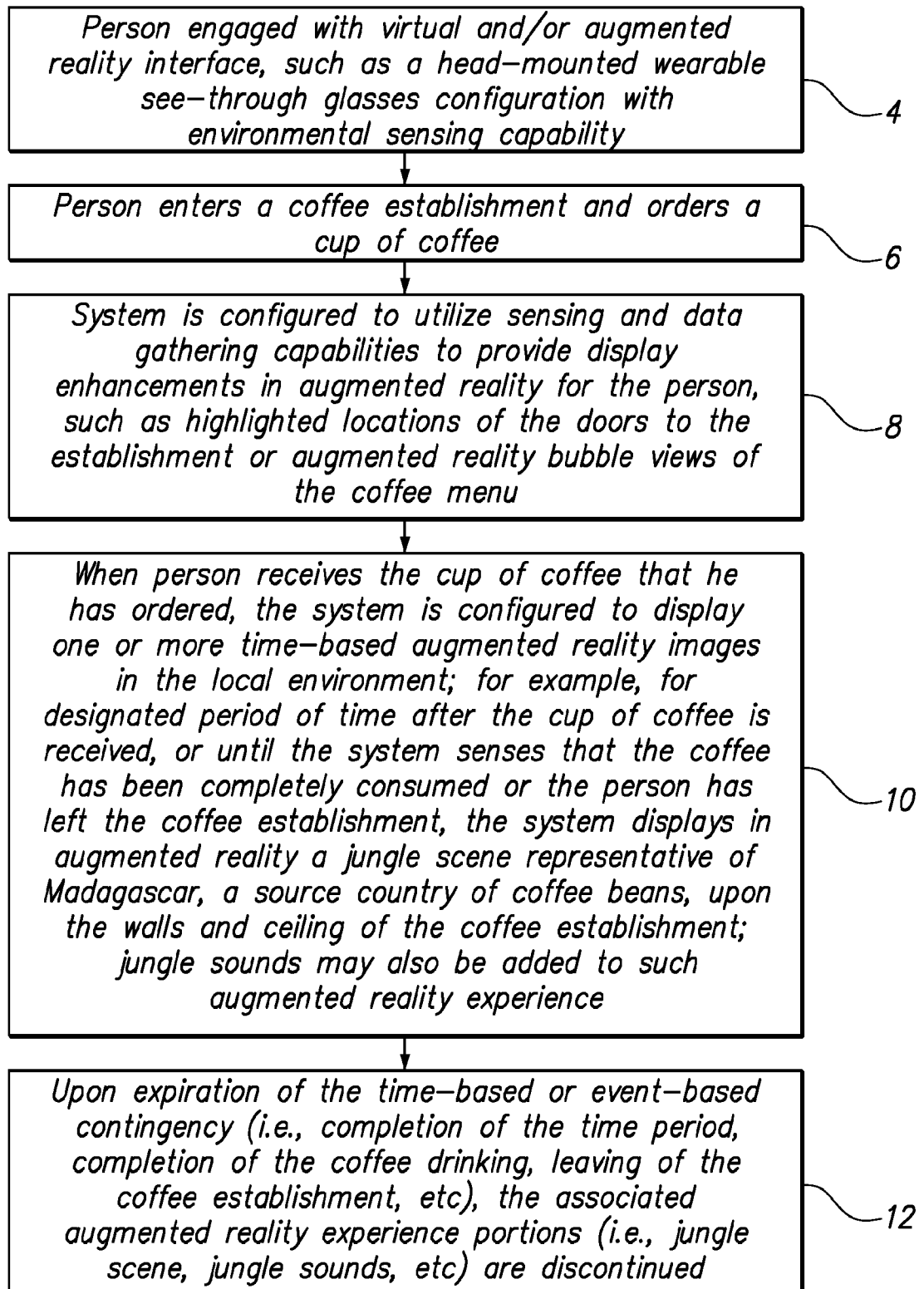

FIG. 12

10/13

**FIG. 13**

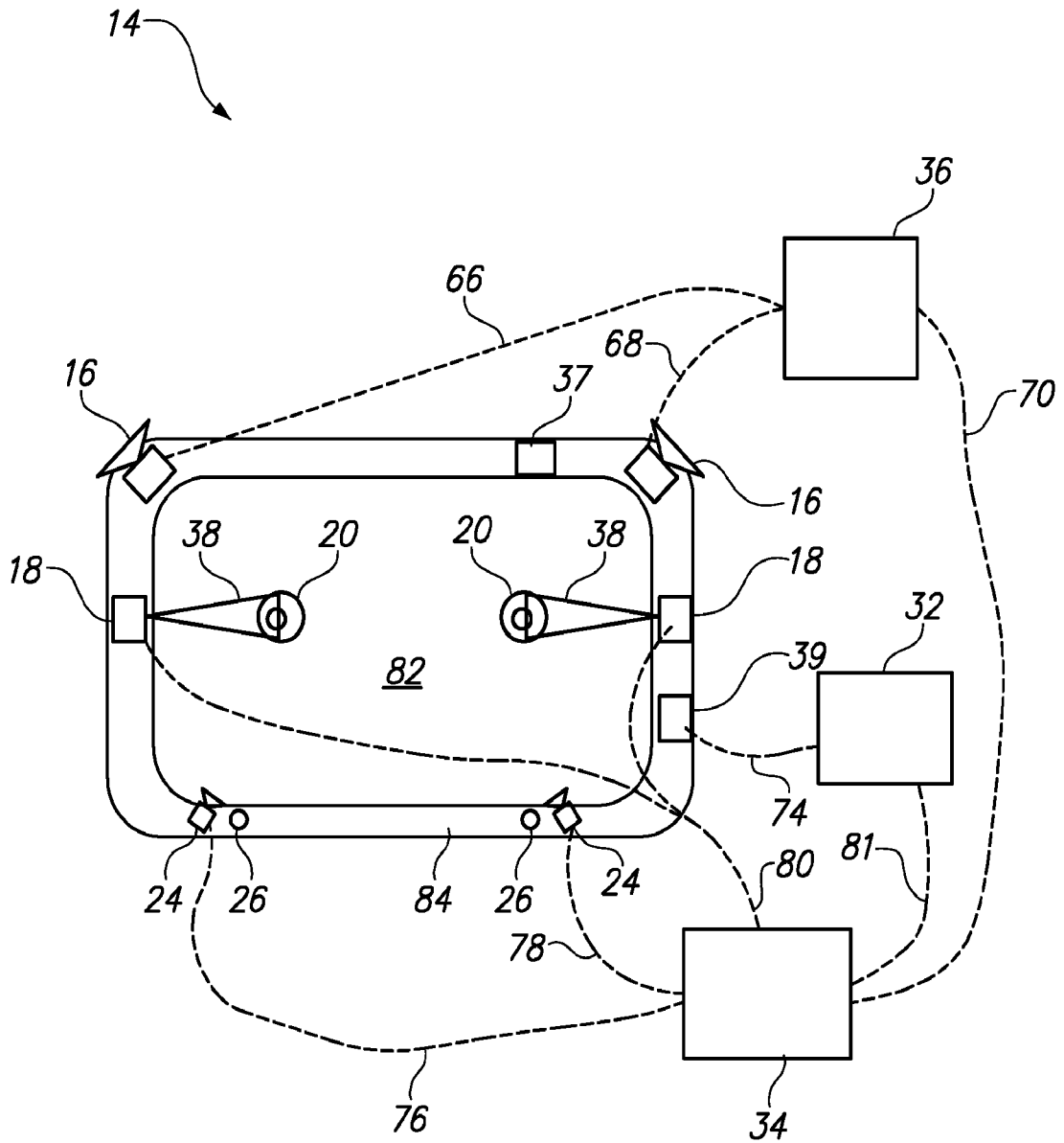

FIG. 14

12/13

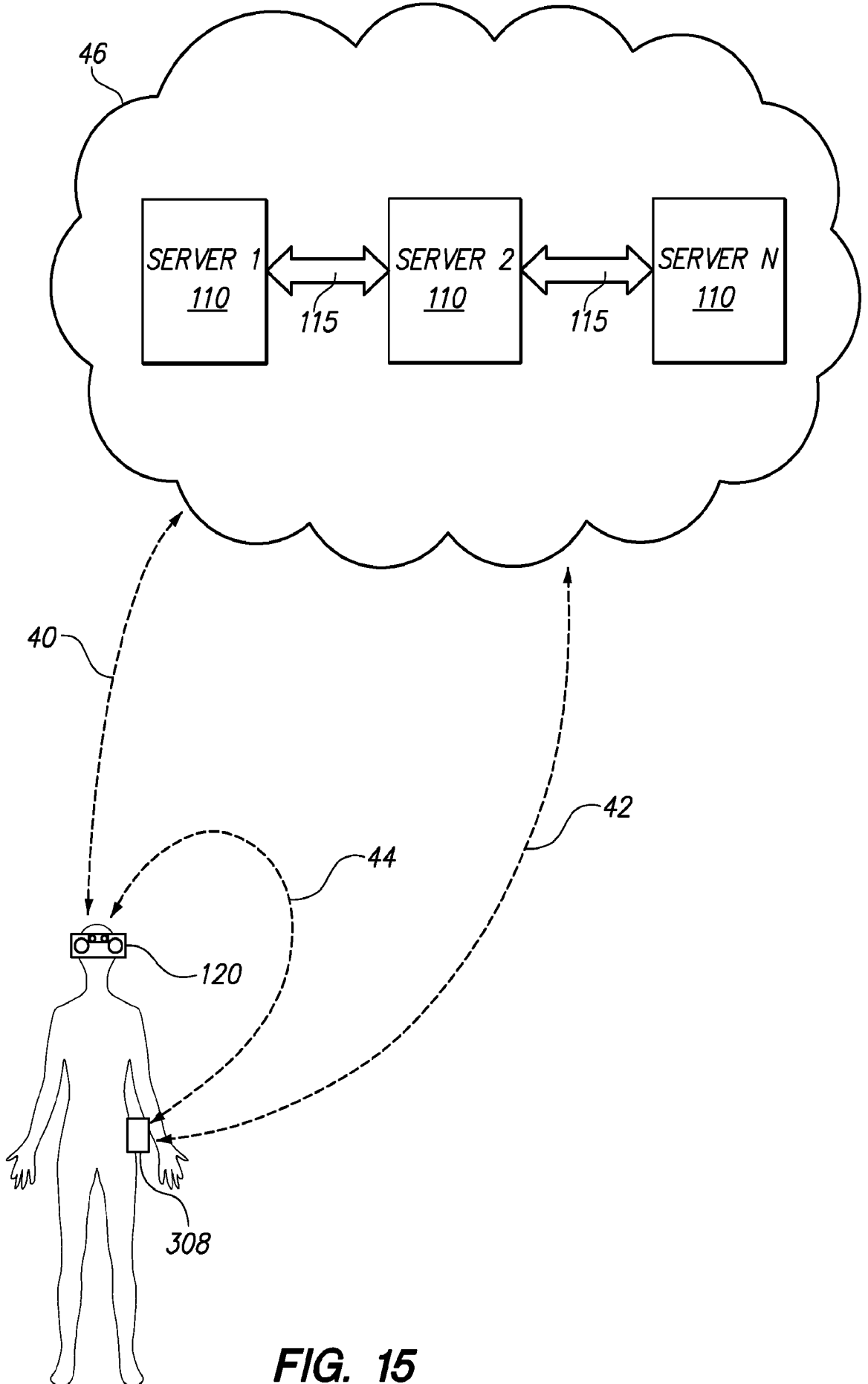

FIG. 15

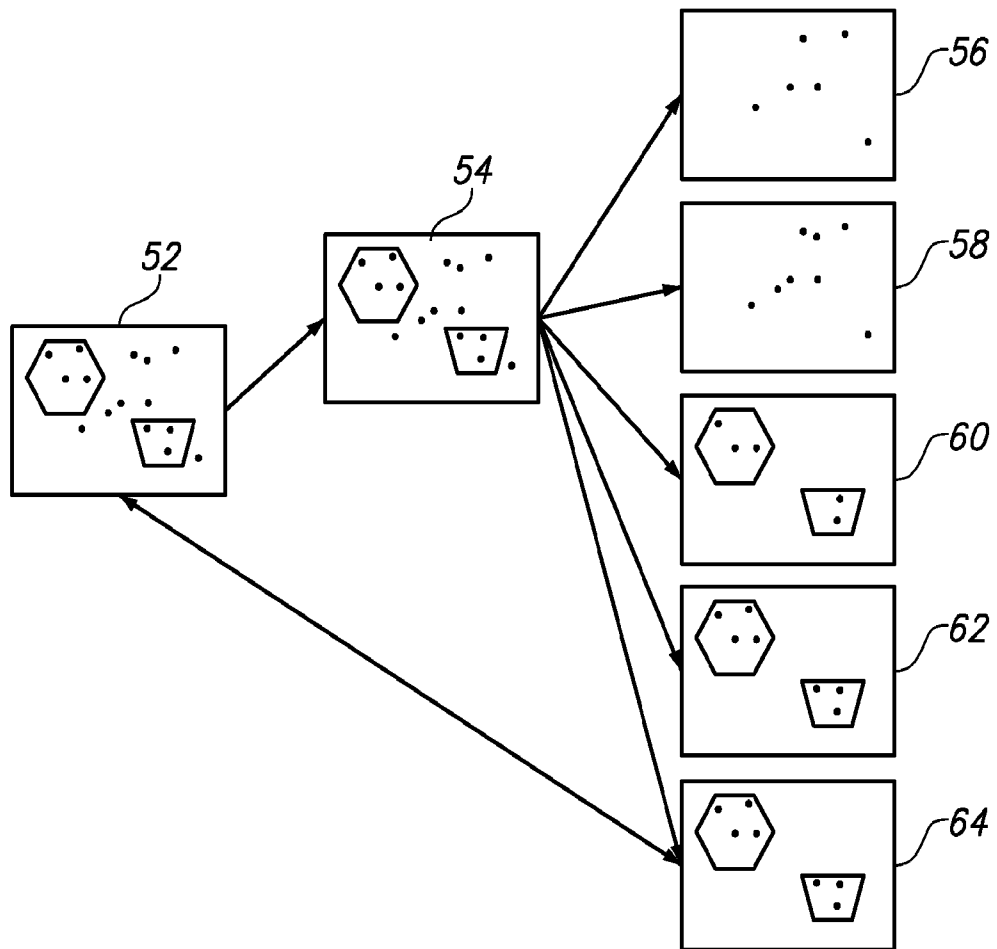

FIG. 16