



- (51) International Patent Classification:  
*G06K 1/18* (2006.01)
- (21) International Application Number:  
PCT/US2013/023149
- (22) International Filing Date:  
25 January 2013 (25.01.2013)
- (25) Filing Language: English
- (26) Publication Language: English
- (30) Priority Data:
 

13/359,352	26 January 2012 (26.01.2012)	US
13/438,131	3 April 2012 (03.04.2012)	US
13/630,248	28 September 2012 (28.09.2012)	US
13/644,714	4 October 2012 (04.10.2012)	US
13/717,363	17 December 2012 (17.12.2012)	US
- (71) Applicant: **DIGITAL LIFE TECHNOLOGIES LLC** [US/US]; 125 Harvest Circle, Bala Cynwyd, PA 19004 (US).
- (72) Inventors: **SPODAK, Douglas**; 125 Harvest Circle, Bala Cynwyd, PA 19004 (US). **FRIDMAN, Ron**; 413 Hilltop Road, Paoli, PA 19301 (US). **O' NEILL, Joseph, A.**; 2825 234th Avenue Southeast, Sammamish, WA 98075 (US).

- (74) Agents: **STEIN, Michael, D.** et al.; Woodcock Washburn LLP, Circa Centre, 12th Floor, 2929 Arch Street, Philadelphia, PA 19104-2891 (US).
- (81) Designated States (*unless otherwise indicated, for every kind of national protection available*): AE, AG, AL, AM, AO, AT, AU, AZ, BA, BB, BG, BH, BN, BR, BW, BY, BZ, CA, CH, CL, CN, CO, CR, CU, CZ, DE, DK, DM, DO, DZ, EC, EE, EG, ES, FI, GB, GD, GE, GH, GM, GT, HN, HR, HU, ID, IL, IN, IS, JP, KE, KG, KM, KN, KP, KR, KZ, LA, LC, LK, LR, LS, LT, LU, LY, MA, MD, ME, MG, MK, MN, MW, MX, MY, MZ, NA, NG, NI, NO, NZ, OM, PA, PE, PG, PH, PL, PT, QA, RO, RS, RU, RW, SC, SD, SE, SG, SK, SL, SM, ST, SV, SY, TH, TJ, TM, TN, TR, TT, TZ, UA, UG, US, UZ, VC, VN, ZA, ZM, ZW.
- (84) Designated States (*unless otherwise indicated, for every kind of regional protection available*): ARIPO (BW, GH, GM, KE, LR, LS, MW, MZ, NA, RW, SD, SL, SZ, TZ, UG, ZM, ZW), Eurasian (AM, AZ, BY, KG, KZ, RU, TJ, TM), European (AL, AT, BE, BG, CH, CY, CZ, DE, DK, EE, ES, FI, FR, GB, GR, HR, HU, IE, IS, IT, LT, LU, LV, MC, MK, MT, NL, NO, PL, PT, RO, RS, SE, SI, SK, SM, TR), OAPI (BF, BJ, CF, CG, CI, CM, GA, GN, GQ, GW, ML, MR, NE, SN, TD, TG).

[Continued on next page]

(54) Title: PORTABLE E-WALLET AND UNIVERSAL CARD

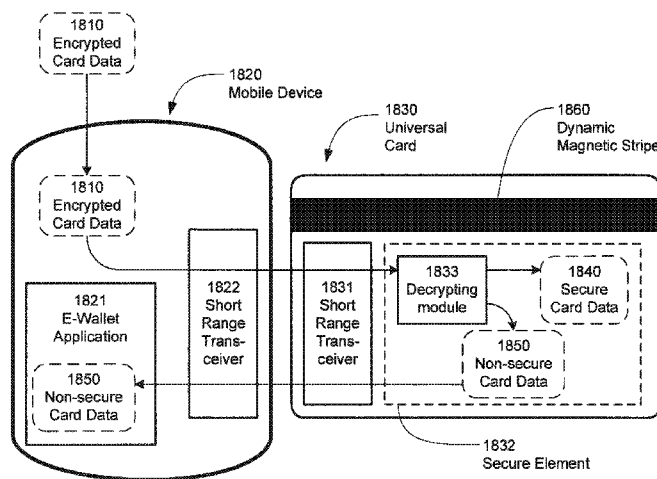
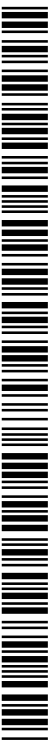


FIGURE 18

(57) Abstract: Universal cards are used in place of all the other traditional cards which a person may want to carry. The universal card can include a short range communications transceiver to communicate with a mobile device. The mobile device can include a user interface and an e-wallet application so that the user can interface with the e-wallet application for programming the universal card via the short range communication link. Once programmed, the universal card emulates a function of a traditional card.





---

**Published:**

— with international search report (Art. 21(3))

— before the expiration of the time limit for amending the claims and to be republished in the event of receipt of amendments (Rule 48.2(h))

## PORTABLE E-WALLET AND UNIVERSAL CARD

## CROSS REFERENCE TO RELATED APPLICATION

[0001] This application claims the benefit of each of United States Patent Application No. 13/717,363, filed December 17, 2012; United States Patent Application No. 13/644,714 filed October 4, 2012; United States Patent Application No. 13/630,248 filed September 28, 2012; United States Patent Application No. 13/438,131 filed April 3, 2012; and United States Patent Application No. 13/359,352 filed January 26, 2012. United States Patent Application No. 13/717,363 is a continuation-in-part of United States Patent Application No. 13/630,248, which is a continuation-in-part of United States Patent Application No. 13/438,131, which is a continuation-in-part of United States Patent Application No. 13/359,352, which is a continuation-in-part of United States Patent Application No. 13/310,491, filed December 2, 2011; and a continuation-in-part of United States Patent Application No. 12/715,977, filed March 2, 2010. United States Patent Application No. 13/644,714 is also a continuation-in-part of United States Patent Application No. 13/438,131. The contents of all of which are herein incorporated by reference in their entirety.

## TECHNICAL FIELD

[0002] The presently disclosed subject matter relates to universal cards, mobile applications, and mobile devices such as mobile phones, Personal Digital Assistants (PDAs), iPods, tablet computers, laptop computers, and similar mobile devices. More particularly, the subject matter relates to a universal card which can be used at any type of terminal equipped with a magnetic stripe reader or a short range wireless communication capability.

## BACKGROUND

[0003] People carry many types of cards with them every day. The cards include credit cards, debit cards, drivers' licenses, transportation passes, building access cards, and many other types of cards. These cards are typically carried in a wallet or purse. A person may need to use any number of cards during the course of a day. Since people do not know which of the cards will be needed on any given day, most people carry all the cards that they may need with them every day. With the proliferation of card-capable terminals, people can end up carrying an inordinate amount of cards with them every day.

[0004] Many people also carry mobile devices with them, such as cell phones, PDAs, tablet computers, laptop computers, and many other types of mobile devices. Mobile devices increasingly have short range communication capabilities, such as near field communication (NFC) capabilities or Bluetooth capabilities.

[0005] A person that carries a wallet or purse also has to secure the contents of the wallet or purse at all times to protect against theft and fraud. If a card is lost or stolen, it can be used in unauthorized ways, leading to identification theft, fraud, or financial loss. In addition, as many transactions are increasingly performed without the need for physically possessing the card (e.g., online purchases), the mere exposure of the information found on a card to an unauthorized person is a risk to the card holder.

[0006] There is a need to reduce the number of cards carried by a person, and an opportunity to address that need using the short range communication capabilities of a mobile device which that person carries. In addition, there is a need to secure cards and card information so that cards and card information is not exposed to unauthorized people.

#### SUMMARY

[0007] To reduce the number of cards carried by a person, a universal card and short range communication enabled mobile device can be used in place of all the other cards which the person may want to carry. The universal card can include a short range communications transceiver to communicate with a mobile device. The mobile device can include a user interface and an e-wallet application so that the user can interface with the e-wallet application for programming the universal card via the short range communication link. Once programmed, the universal card emulates a function of a traditional card, such as emulating the magnetic stripe of the traditional card, the NFC communication of the traditional card, the radio transmission of the traditional card, or any other function.

#### BRIEF DESCRIPTION OF THE DRAWINGS

[0008] The foregoing Summary, as well as the following Detailed Description, is better understood when read in conjunction with the appended drawings. In order to illustrate the present disclosure, various aspects of the disclosure are shown. However, the disclosure is not limited to the specific aspects shown. The following figures are included:

[0009] Figure 1 depicts an exemplary system including a mobile device and a universal card.

[0010] Figure 2 depicts a traditional card with a static magnetic stripe.



[0011] Figure 3 depicts a flowchart process for programming a universal card.

[0012] Figure 4 depicts interactions between a mobile device and a universal card, and between a universal card and three different types of terminals.

[0013] Figure 5 depicts an exemplary system including a personal computer, a mobile device, and a universal card.

[0014] Figure 6 depicts a flowchart process for managing universal card data using a mobile device.

[0015] Figure 7 depicts a flowchart process for managing universal card data using a personal computer.

[0016] Figures 8A, 8B, 8C, and 8D depict possible designs for the front of a universal card.

[0017] Figure 9 depicts a possible design for the back of a universal card.

[0018] Figures 10A and 10B depict an embodiment of a universal card with an integrated circuit.

[0019] Figures 11A and 11B depict an embodiment of a universal card with a secure element.

[0020] Figures 12A and 12B depict an embodiment of a universal card with an integrated circuit and a secure element.

[0021] Figure 13 depicts an embodiment of a universal card with a power indicator.

[0022] Figure 14 depicts an embodiment of a universal card with an activation switch.

[0023] Figures 15A and 15B depict ways to add traditional card data to a secure element of a universal card.

[0024] Figure 15C depicts a way to add traditional card data to a secure element of a mobile device.

[0025] Figure 16 depicts an exemplary electronic card data delivery system.

[0026] Figure 17 depicts an exemplary method of providing card data to a universal card.

[0027] Figure 18 depicts embodiments of a system and method of securely loading card data onto a universal card that has a secure element

[0028] Figures 19A, 19B, and 19C depict several embodiments of systems and methods for providing card encrypted to a mobile device for transmission to a universal card with a secure element.

[0029] Figure 20 depicts an embodiment of a method of securely transferring secure card data to a universal card and non-secure card data to a mobile device.

[0030] Figures 21A and 21B depict embodiments of a mobile device obtaining and using RF card data in conjunction with a universal card.

[0031] Figure 22 depicts an embodiment of a system and method of using a universal card as a proxy card.

[0032] Figure 23 depicts an embodiment of a system and method of using a universal card as a proxy card when a mobile device is unable to communicate with a proxy card server.

[0033] Figure 24 depicts an embodiment of a method of using a universal card in a proxy card transaction.

[0034] Figures 25A and 25B depict embodiments of universal cards for use with multiple proxy card types that each have an associated default card.

[0035] Figure 26 depicts an embodiment of a system and method of using a universal card with multiple proxy card types where each of the proxy card types has an associated default card.

[0036] Figure 27 depicts another embodiment of a system and method of using a universal card with multiple proxy card types where each of the proxy card types has an associated default card.

[0037] Figures 28A and 28B depict embodiments of universal cards for use with multiple proxy card types that each have an associated default card.

[0038] Figure 29 depicts an embodiment of a system and method of using a universal card with default cards stored locally on the universal card

[0039] Figures 30A to 30C depict an embodiment of a universal card with a dynamic EMV chip.

[0040] Figures 31A and 31B depict embodiments of storing EMV card data in a universal card.

[0041] Figure 32 depicts an embodiment of a method of handling encrypted EMV card data by a computing device and a universal card.

#### DETAILED DESCRIPTION OF ILLUSTRATIVE EMBODIMENTS

[0042] Referring to Fig. 1, an exemplary system is depicted with a mobile device 100 and a universal card 110. The mobile device 100 can be any number of devices, including a cell phone, a PDA, an iPod, a tablet computer, an NFC-specialized device, or any other type of mobile device. An NFC-specialized device is a device that provides for the user to be able to communicate with NFC terminals, such as making a contactless payment, and would also

provide a user with a user interface for interacting with an NFC-enabled universal card. The mobile device 100 may include any number of components, such as a processor 101, memory 102, a power source 103, a user interface 104, and a short range transceiver 106. Memory 102 can be any type of computer storage media in the form of volatile and/or nonvolatile memory such as read only memory (ROM) and random access memory (RAM). Processor 101 can operate on data and/or software applications available in the memory 102. The user interface 104 can include any components for user input, such as a keyboard, a mouse, a trackball, a touch screen display, or any similar component. The user interface 104 can also include security features on the mobile device, such as a PIN/password login, a fingerprint scanner, other biometric readers, or similar security features.

[0043] The mobile device 100 also includes an e-wallet application 105 which is executable by the processor 101. The e-wallet application 105 can be pre-installed on the mobile device 100 by the manufacturer of the mobile device 100. The e-wallet application 105 can also be installed by the user either by downloading it directly to the mobile device 100, by downloading the e-wallet application 105 over-the-air via a wireless data connection, or by inserting a memory card containing the e-wallet application 105.

[0044] The e-wallet application 105 allows the user to input information about traditional cards for storage in the memory 102. Information about traditional cards can include an account name, an account number, an expiration date, a card verification value 2 (CVV2), the image of the traditional card, the information which would be stored on the magnetic stripe of the traditional card, and any other information necessary to emulate the card. The information about traditional cards can also be stored in a remote location, such as a trusted service manager (not shown), which stores the information and provides the information to the mobile device 100 on demand via wireless data communication. In this case, the e-wallet application 105 would interface with the remote location to request and receive the information.

[0045] The e-wallet application 105 can also be used to program the universal card 110 by allowing the user to select a traditional card for the universal card to emulate. The universal card 110 can be configured to emulate any number of traditional cards, including credit cards, debit cards, drivers' licenses, transportation passes, building access cards, and any other types of cards. Once the user selects a card for emulation, the e-wallet application 105 causes the mobile device to communicate with the universal card and to transmit the information necessary for the universal card to emulate the selected traditional card.

[0046] In another universal card embodiment, the information about the traditional card could be stored in the memory 115 of the universal card 110. In this embodiment, if the

universal card 110 has a user interface with sufficient capabilities, the user may be able to program the card by using the user interface on the universal card 110.

[0047] The short range transceiver 106 can be configured to communicate via any type of short range communication link, such as an NFC communication link or a Bluetooth communication link. The mobile device 100 may be manufactured with the short range transceiver 106. However, not all mobile devices are initially manufactured with short range transceivers. The short range transceiver 106 may be located on a memory card compatible with a memory slot of the mobile device 100. In this situation, the memory card with the short range transceiver 106 is inserted into the memory slot (not shown) of the mobile device 100 such that the mobile device can transmit and receive information using a short range communication link corresponding to the short range transceiver 106.

[0048] Another issue with the short range transceiver 106 may arise if the short range transceiver 106 of the mobile device and the short range transceiver 116 of the universal card 110 are not configured for the same type of short range communication. For example, mobile device 100 may have a Bluetooth transceiver, and the universal card 110 may have an NFC transceiver. In such a situation, the short range transceiver 106 would be a two-type transceiver, capable of communicating via both types of short range communication. In the example above, the short range transceiver 106 would be capable of receiving information via the Bluetooth link from the mobile device 100, and also capable of sending that information via the NFC link to the universal card 110. The short range transceiver 106 would also be capable of communicating in the opposite direction, receiving information via the NFC link from the universal card 110 and sending that information via the Bluetooth link to the mobile device 100. One example of a two-type transceiver is a MyMax sticker produced and sold by TwinLinx of France. The MyMax sticker can be attached to the housing of a Bluetooth-enabled device, can communicate with the device via a Bluetooth connection, and can communicate via an NFC connection with an NFC-enabled device.

[0049] Also depicted in Fig. 1 is a universal card 110. The universal card 110 may include components such as a display 112, a power source 113, a processor 114, and memory 115. Each of those components are similar in function to the corresponding components of the mobile device 100, except that the component of the universal card 110 may be physically configured differently so as to fit in the shape of the universal card 110. For example, the display 112 of the universal card 110 may be integrated into universal card 110 via hot lamination processes and standard inlay constructs so that the universal card 110 will be the

approximate shape and size of a traditional credit card and generally compliant with ISO 7810 standards.

[0050] The universal card 110 may also include a dynamic magnetic stripe 111 which can be configured to emulate the magnetic stripe of any traditional card. The standard magnetic stripe format is defined by ISO/IEC 7810:2003, and its extensions, including ISO/IEC 7811-1:2002 through ISO/IEC 7811-9:2008, and ISO/IEC 7813:2006, each of which are hereby incorporated by reference. Traditional magnetic stripes include a series of tiny bar magnets which can be magnetized in either a north- or south-pole direction. When the polarity of the bars aligns in the same direction, the card is blank. To write data to the card, the polarity of a bar is reversed so that the north pole is facing the north pole of the adjacent bar (N-N) or the south pole is facing the south pole (S-S). This causes a change in the magnetic field that can be detected by a card reader. The two possible flux reversals, N-N or S-S, can represent two different information states, which corresponds nicely to the binary system (ones and zeros) used by computers.

[0051] Magnetic stripes have three standard track layouts: Track 1, Track 2, and Track 3. Referring to Fig. 2, depicted is a traditional card 201 with a static magnetic stripe 202. The static magnetic stripe includes each of Tracks 1, 2, and 3, shown as 203, 204, and 205, respectively. Each of the track layouts are 0.110 inches high. Track 1 has 210 bits per inch (bpi) with room for 79 characters of 7 bits each (6 data bits, plus 1 parity bit). Track 2 has 75bpi with room for 40 characters of 5 bits each (4 data bits, plus 1 parity bit). Track 3 has 210bpi with room for 107 numeric digits. Tracks 1 and 2 have a standard for the data content contained in each track. Those standards are shown in Tables 1 and 2 below. In contrast, Track 3 does not have a standard for the data content in the track, and can be used for proprietary data formats.

**Table 1 – Standard Track 1 Data Content in Magnetic Stripe of Financial Cards**

<b>Data Field</b>	<b>Content of Data Field</b>
Start sentinel	1 byte (the % character)
Format code	1 byte alpha ("A" is reserved for proprietary use of the card issuer; "B" is a standard for financial institutions; "C" – "M" are reserved for use by ANSI; and "N" – "Z" are available for use by individual card issuers)
Primary Account number	Up to 19 characters
Separator	1 byte (the ^ character)
Country code	3 bytes (optional)
Surname	Variable number of bytes
Surname separator	1 byte (the / character)
First name or initial	Variable number of bytes

Space	1 byte (used only when more data follows the first name or initial)
Middle name or initial	Variable number of bytes
Period	1 byte (the . character; used only when followed by a title)
Title	Variable number of bytes (optional)
Separator	1 byte (the ^ character)
Expiration date or separator	4 bytes (YYMM format), or a 1-byte separator if non-expiring card
Discretionary data	Variable number of bytes (optional; can be used by the card issuer)
End sentinel	1 byte (the ? character)
Longitudinal redundancy check	1 byte

**Table 2 – Standard Track 2 Data Content in Magnetic Stripe of Financial Cards**

<b>Data Field</b>	<b>Content of Data Field</b>
Start sentinel	1 byte (the ; character)
Primary account number	Up to 19 bytes
Separator	1 byte (the = character)
Country code	3 bytes (optional)
Expiration date or separator	4 bytes (YYMM format), or a 1-byte separator if non-expiring card
Discretionary data	Variable number of bytes (optional; can be used by the card issuer)
End sentinel	1 byte (the ? character)
Longitudinal redundancy check	1 byte

[0052] Traditional financial cards from the banking industry, such as credit cards and debit cards, typically use both Tracks 1 and 2, with Track 2 using format code “A” or “B”. Some traditional credit and debit cards do not have Track 3 physically present on the cards as its data is not necessary for the cards’ use. Eliminating Track 3 can reduce the physical size of the magnetic stripe. Traditional financial cards usually include all of the data listed in Tables 1 and 2.

[0053] Traditional gift cards typically use Track 2 with format code “B”. Those cards usually have a unique account number, but usually do not contain the name of the user in the track. Some traditional gift cards can include the amount available at the time of the original purchase in the magnetic track, and some will store the current balance on the card so that the card can be used at any terminal. However, most traditional gift cards do not have any value data stored on the card; the card merely stores the unique account number, and each terminal at

the store is connected to a database, where the value of the card is associated with the unique account number.

[0054] Traditional loyalty cards typically use Track 2 with format code “B”. Like traditional gift cards, traditional loyalty cards typically include only a unique account number without storing any data about the user or any monetary value associated with the card. Most terminals which accept loyalty cards are connected to a central database which associates data about the user with the unique account number. Some traditional loyalty cards also include a barcode printed on the face of the card so that the card can be read by a barcode scanner. The barcode is representative of the unique account number of the user, and typically has no other data encoded in the barcode itself.

[0055] Many driver’s licenses issued in the United States have a magnetic stripe on them. Driver’s licenses typically include Tracks 1, 2, and 3. The data content of Tracks 1 and 2 are shown in Table 3. The data content of Track 3 is not entirely standardized, but Track 3 typically includes at least some of the following data categories: template number, security number, postal code, class, restrictions, endorsements, sex, height, weight, hair color, eye color, ID number, error correction, and security field.

**Table 3 – Standard Track 1 and Track 2 Data Content of US Driver’s Licenses**

<b>Track 1 Data Fields</b>	<b>Content of Data Field</b>
Start sentinel	1 character (usually the % character)
State or province	2 characters
City	Up to 13 characters (variable length)
Field separator	1 character (usually the ^ character), unless the City field is maxed out
Last name	Variable length
Field separator	1 character (usually the \$ character)
First name	Variable length
Field separator	1 character (usually the \$ character)
First name	Variable length
Field separator	1 character (usually the ^ character)
Home address	Variable length (usually house number and street)
Field separator	1 character (usually the ^ character)
Discretionary data	Variable length
Start sentinel	1 character (usually the ^ character)
<b>Track 2 Data Fields</b>	<b>Content of Data Field</b>
ISO issuer ID number	6 character
License/ID number	8 character
Field separator	1 character (usually the = character)

Expiration date	4 characters (usually YYMM format)
Birth date	8 characters (usually YYYYMMDD format)
License/ID number overflow	Variable length

---

**[0056]** Traditional access cards are used to provide access to the card holder to a building or other secure area. Traditional access cards typically use either a magnetic stripe or a radio transmitter to convey information to a terminal. When using a magnetic stripe, the data encoded on the magnetic stripe typically includes the user's name, an ID number associated with the user, and an access level relating to where and when the user is allowed access. When using a radio transmitter, the access card typically only includes an ID number associated with the user, and the access terminal is connected to a database which contains information about the user and the access level based on the ID number. Radio transmitters in access cards can either be "active" radio transmitters (powered by a power source on the card), or "passive" radio transmitters (powered by the radio receiver in the terminal when the card is brought into close proximity with the terminal).

**[0057]** Referring back to Fig. 1, universal card 110 can also include a radio communications apparatus 117 to emulate an access card which uses a radio communications apparatus. Radio communications apparatus 117 can either be a passive radio transmitter, or an active radio transmitter powered by power source 113. The ID number transmitted by the radio communications apparatus 117 can be programmed so that the universal card can be programmed to emulate different traditional access cards. When programming the universal card 110 to emulate an access card, it may be desirable to verify the identity of the user prior to programming the universal card 110. Examples of user verification are discussed below.

**[0058]** Other types of traditional cards exist and can be emulated by universal card 110. Examples of dynamic magnetic stripes are shown in US Patent Application Publication 2005/0194452, applied for by Nordentoft et al, and 2007/0189581, applied for by Nordentoft et al. In these examples, individually inducible transducer coils are positioned within a universal card and are configurable to emulate the static magnets in a traditional magnetic stripe. The dynamic magnetic stripe 111 of the universal card can be configured to emulate any traditional static magnetic stripe, including any data or data format used by a static magnetic stripe. Thus, even if a data content format is not discussed here, dynamic magnetic stripe 111 would be capable of emulating the data content format not discussed here.



[0059] Universal card 110 may include a biometric security device 118, such as a fingerprint reader, a microphone for voice identification, or other device for input during biometric identification. The use of such biometric identification for security is discussed below.

[0060] Referring now to Fig. 3, depicted is a flowchart process for programming a universal card. To initiate power on the universal card (UC) the user may be required to take an action that may include pushing a button on card to turn it "on", is tapped 301, or any other similar technique. The universal card's power is verified 302. If the power is not on, the user will repeat the action to initiate power 301 on the universal card again. If the power is on, the universal card and the mobile device are paired 303, establishing the short range communication link 120 (as shown in Fig. 1). The pairing is verified 304, with the pairing 303 attempted again if the pairing is not successful. Once paired, an e-wallet application on the mobile device is automatically launched 305. If the e-wallet application is not automatically launched 306, it can be manually launched 307 on the mobile device.

[0061] Before allowing access to view, change or modify the financial data associated with the e-wallet program 105 on the mobile device 100 or on the universal card 110, the user must first be authenticated 308. Authentication can take a number of forms. One form of authentication can be verification of something that the user has in their possession. In this context, one security feature could be that the mobile device 100 can only be paired with one universal card 110, and the universal card 110 will only pair to one mobile device 100. For example, if a user's mobile device 100 is lost or stolen, the universal card 110 will not pair with any other mobile device. Thus, any personal card information stored on the universal card 110 will not be accessible by another mobile device.

[0062] Another form of user authentication can be verification of something that the user knows. This can be a personal identification number (PIN), a unique identification of the user (such as a social security number), a fact about the user (such as the maiden name of the user's mother), a password, or anything else that the user can input. Yet another form of user authentication is something about the user. This can include a fingerprint, a voice identification, or other verifiable biometric.

[0063] While each of these forms of authentication can alone authenticate the user, it may be desirable to require at least two forms of authentication to ensure increased security. For example, the mobile device 100 and the universal card 110 may authenticate each other as being paired; however, this fact alone does not ensure that the person operating the devices is the authentic user. In this case, it may be advantageous to require the user to enter a password to verify that the user is authentic. In some instances, the issuer of the card may impose additional

requirement depending on the circumstances that the card is being used. For example, if the card is being used to make a payment over a certain value, if the card is being used in a foreign country, or if the card issuer has reason to suspect that the use of the card is unauthorized, the issuer may require another level of authentication. In this case, if the initial authentication included pairing authentication and a user password, the issuer may require an additional biometric authentication.

[0064] Any user input required for authentication can be entered into either the universal card 110 or the mobile device 100. The universal card 110 may have a user interface (not shown), an optional biometric security device 118, or other input mechanism which allows the user to input the required value. Similarly the mobile device 100 may have a user interface 104, an optional biometric security device (not shown), or other input mechanism.

[0065] Once the user authentication 308 occurs (e.g., a password is entered), the authentication is verified 309 (the entered password is verified). If the authentication was not successful, user authentication 308 can be attempted again. If the authentication is successful, the user is prompted to select 310 an action for programming the universal card.

[0066] Notwithstanding the foregoing, it should be clear to a person skilled in the art that radio interfaces 120, 410, 430, 450, 510, and 520 may be subject to eavesdropping or other intrusive information breaches can be protected by data encryption technologies public key, private key and other known and standard methods of radio protection.

[0067] The universal card can be programmed in many ways, including three distinct modes. First, the universal card can be programmed in a “dummy card” mode, where the universal card does not itself store any of the information required for emulation of a traditional card. In this case, the user must use the mobile device to program the universal card for each use of the card. Once the universal card is used once as programmed, it would not retain that programmed setting, and it would require re-programming if it were to be used again. Second, the universal card can be programmed in a “temporary card” mode, where the universal card stores only one set of information required for emulation. The user utilizes the mobile device to program the card to emulate a specific card either for a set amount of time or number of transactions. Once programmed in this mode, the universal card would remain programmed to emulate that one card for the set time or the number of transactions. If the user wanted to change the universal card to emulate a different card, the user would need to reconnect the mobile device to reprogram the card. Third, the universal card can be programmed in a “default card” mode, where the universal card always emulates a specific card, unless programmed otherwise. In this mode, the information of the default card is saved in the universal card and the universal card is

always configured to emulate the default card, unless the user re-programs the universal card to temporarily act as another card or to change to a new default card.

[0068] It may also be possible to program the universal card in different modes for the various ways in which the universal card can be used. For example, a universal card which has both a dynamic magnetic stripe and an NFC transceiver can be used to interface with both magnetic stripe readers and NFC-equipped terminals. The user may use the universal card as a public transportation pass which makes fare payments to an NFC-equipped terminal, and as a credit card with a magnetic stripe reader. In such a case the user may program the NFC transceiver to operate in a “default card” mode, always capable of emulating the public transportation pass, but program the dynamic magnetic stripe in a “dummy card” mode where the user must program the universal card with a specific credit card to emulate before each transaction.

[0069] Once the user selects 310 an action for programming, the data required for the programming action is determined 311. In order for the universal card to be programmed to emulate a magnetic stripe of a payment card, the universal card would need all the data required to be in the dynamic required stripe. The data could include all the information needed to fill Track 1 and Track 2, as discussed above and shown in Tables 1 and 2. The required data may be stored on the mobile device, the universal card, or a remote location such as a trusted service manager. If it is determined 312 that the required data is not available, the user is prompted to select 310 another action for programming.

[0070] If the required data is available, the universal card is programmed 314 to emulate the selected card with the required data. If the required data is stored only on the mobile device, the programming 314 will include transmitting the required data to the universal card via the short range communication link. If the required data is stored on the universal card, the programming 314 need only include configuring the appropriate device (e.g., dynamic magnetic stripe, short range transceiver, radio transmitter, etc.) properly for emulation.

[0071] Referring to Fig. 4, depicted are interactions between the mobile device 100 and the universal card 110, and between the universal card 110 and three different types of terminals 400, 420, and 440. As discussed above, the mobile device 100 communicates with the universal card 110 via a short range communications link 120 to program the universal card 110 for emulation of traditional cards. The universal card 110, in turn, can communicate with terminals 400, 420, and 440 in a number of ways. It is important to note that, once universal card 110 is programmed, the short range communications link 120 between the mobile device 100 and the

universal card 110 need not be established for the universal card 110 to interact with the terminals 400, 420, and 440.

[0072] Terminal 400 is equipped with a magnetic stripe reader 401 which can read the dynamic magnetic stripe 111 of the universal card 110 when it is swiped 410 through the magnetic stripe reader 401. The magnetic stripe reader 401 can read any of the data written to the dynamic magnetic stripe 111. Terminal 420 is equipped with a short range transceiver 421 which can establish a short range communication link 430 between the universal card 110 and the terminal 420. Any required data can be transmitted from the universal card 110 to the terminal 420 via the short range communication link 430. Terminal 440 is equipped with a radio receiver 241 which can receive data sent from the radio transmitter 117 of the universal card 110. Any required data can be transmitted from the universal card 110 to the terminal 440 via the radio link 450.

[0073] One potential problem with the e-wallet software 105 on the mobile device 100 is that large amounts of information may need to be inputted into the e-wallet software 105. The user interface 104 may not be convenient for entry of the large amounts of information. Also, management of the information in the e-wallet software 105 may also not be convenient via the user interface 104. To address this issue, a personal computer 500 can be used.

[0074] Referring to Fig. 5, depicted is an exemplary system including the personal computer 500, the mobile device 100, and the universal card 110. The personal computer can include a processor 501, memory 502, a power source 503, a user interface 504, the e-wallet software 505, and a communications port 506. The processor 501, memory 502, power source 503, and user interface 504 are all similar in function to the corresponding components of the mobile device 100, as discussed above. The e-wallet software 505 can be the same or similar to e-wallet software 105 of the mobile device 110. The user may enter data and manage the card data in e-wallet software 505 in the same way the user would use e-wallet software 105.

[0075] When the user enters data or makes changes in the management of e-wallet software 505, the e-wallet software 105 on the mobile device 100 must be updated to reflect the new and/or changed data. In order to make these updates, a communication link 510 can be established between the communication port 506 of the personal computer 500 and the communication port 107 of the mobile device 100. The communication link 510 can be any type of wired or wireless link, including a serial cable, a wired or wireless local area network (LAN), a wired or wireless wide area network (WAN), a short range communication link, a radio link, or any similar connection. Alternatively, a communication link 520 can be established between a

short range transceiver 507 of the personal computer 500 and the short range transceiver 106 of the mobile device 100.

[0076] Once a communication link is established between the personal computer 500 and the mobile device 100, the data in e-wallet software 505 and the e-wallet software 105 can be synchronized. It is important to note that the short range communication link 120 between the universal card 110 and the mobile device 100 need not be active for the link 510 or the link 520 to be established between the personal computer 500 and the mobile device 100.

[0077] Referring to Fig. 6, depicted is a flowchart process for managing universal card data using mobile device 100. The e-wallet software is launched 601 on the mobile device. Before the user is given access to the e-wallet software, the user must first login and be authenticated 602. Authentication here can be the same or similar to the forms of authentication discussed above. A determination is made whether the authentication is successful 603. If not successful, the user is prompted to login and authenticate 602 again. If the authentication is successful, the user is allowed to control 604 the e-wallet software a user interface of the mobile device.

[0078] The control 604 of the e-wallet software includes anything that the user may need to do to prepare for programming the universal card or to program the universal card. The user can enter data associated with a traditional card or with a financial account. The user can manage the entered data such as by naming a particular account or traditional card, setting a default card, or any other management action needed.

[0079] After the user enters data, the data is verified 605. The verification can include determining whether sufficient data has been entered for emulation of a traditional card, or whether the data entered matches the data of the card issuer. If the data is not verified, the user is allowed to reenter data 604. If the data is verified, the data is encrypted 606 for storage. Encrypting the data for storage is another form of security, as someone that gains access to the encrypted data cannot recover the entered data without knowing how to decrypt the encrypted data. After the data is encrypted, the encrypted data can be stored 607 to the mobile device.

[0080] A determination 608 is made as to whether the encrypted data should be uploaded to the personal computer. If the encrypted data will not be uploaded, no further action is required. If the encrypted data will be uploaded to the personal computer, the communication connection between the mobile device and the personal computer is either established or checked 609. If the connection to the computer is not verified 610, another attempt to establish 609 the connection can be attempted. Once the connection to the computer is verified 610, the encrypted data can be uploaded and saved 611 to the personal computer.

[0081] Referring to Fig. 7, depicted is a flowchart process for managing universal card data using personal computer 500. Many of the steps are similar to those depicted in Fig. 6. The PC version of the e-wallet software is launched 701. The user goes through login and authentication 702 which is verified 703. Once the user authentication is verified, the user can control 704 the e-wallet software via a user interface of the personal computer. The control on the personal computer is the same as the control on the mobile device, except that the user may prefer to use the user interface of the personal computer to the user interface of the mobile device.

[0082] Data entered on the personal computer can be verified 705. Once verified, the data is encrypted 706 for storage. The encrypted data is stored 707 on the personal computer. A determination 708 is made as to whether the encrypted data should be uploaded to the mobile. If the encrypted data will not be uploaded to the mobile device, the no further action is required. If the encrypted data will be uploaded, the communication connection between the mobile device and the personal computer is either established or checked 709. If the connection to the computer is not verified 710, another attempt to establish 709 the connection can be attempted. Once the connection to the computer is verified 710, the encrypted data can be uploaded and saved 711 to the mobile device.

[0083] The visible sides of a universal card may be designed in a number of ways to provide a user with access to information or components of the universal card. Fig. 8A depicts one design of the front of a universal card 800. The front of the universal card 800 can have a brand area 801 which can be used to identify the brand of the universal card issuer, the brand of a wireless carrier, the brand of a sponsor, any other brand, or any combination of those brands. The front of the universal card 800 can have the name of the card holder 802 on the face of the card to identify the user. The front of the universal card 800 can also have a display 803 which could be used at various times to display an account number, an expiration date, a card issuer logo, any other information, or any combination of these types of information. The front of the universal card 800 could also include a biometric security reader 804, such as a fingerprint reader, which is used to authenticate the user.

[0084] Figs. 8B, 8C, and 8D depict other possible designs for the front of a universal card. Fig. 8B depicts the front of a universal card 810 which is similar to the front of universal card 800, including a brand area 811, the name of the card holder 812, a display 813, and a biometric security reader 814. The front of the front of the universal card 810 can also have an EMV chip 815 which is a required component of cards in some markets including some European markets. Fig. 8C depicts the front of a universal card 820 which is similar to the front

of universal card 800, including a brand area 821, the name of the card holder 822, and a biometric security reader 824; however, the front of universal card 820 does not include a display. Fig. 8B depicts the front of a universal card 830 which similar to the front of universal card 800, including a brand area 831, the name of the card holder 832, a display 833, and a biometric security reader 834. The front of universal card 830 also shows that the name of the card holder 832 and the display 833 can be located in various locations on the front of a universal card.

[0085] Fig. 9 depicts one design of the back of a universal card 900. The back of universal card 900 can include a dynamic magnetic stripe 901 for interacting with a terminal, a signature area 902 which displays the signature of the card holder, and a brand area 903. Similar to the brand area 801 described above, brand area 903 can be used to identify the brand of the universal card issuer, the brand of a wireless carrier, the brand of a sponsor, any other brand, or any combination of those brands.

[0086] Figs. 10A and 10B depict an embodiment of a universal integrated circuit card. In general, an integrated circuit card (also sometimes referred to as a "contact card," an "IC card," a "chip and PIN card," an "EMV card," and so forth) is a card that has an embedded integrated circuit and can be authenticated automatically using a PIN. To reduce fraud, banks and retailers are replacing traditional magnetic stripe equipment with integrated circuit cards. When a customer wishes to pay for goods using this system, the card is placed into a "PIN pad" terminal or a modified swipe-card reader, which accesses the chip on the card. Once the card has been verified as authentic, the customer enters a PIN, which is submitted to the chip on the integrated circuit cards. The chip verifies whether the PIN is correct and replies accordingly to the terminal. Integrated circuit cards have been effective to significantly cut card-present (face-to-face) fraud.

[0087] The EMV standard is one standard that has been developed for integrated circuit cards; the EMV standard defines the physical, electrical, data, and application interactions between an integrated circuit card and the terminal. As mentioned above, an EMV chip is a required component of cards in some markets including some European markets. Other forms of integrated circuit cards, such as the Chip and PIN system, are used in other markets.

[0088] Increasingly it is becoming important for US citizens to have a card with both a magnetic stripe and an integrated circuit, so that when a person is traveling internationally it is easier for them to pay with a US credit card. In many countries, merchants reject credit cards with only a magnetic stripe. Thus, in order for a universal card to be usable world-wide, it must also include an integrated circuit. One difficulty with including an embedded integrated circuit

with a universal card is that the integrated circuit can be associated only with a single credit or debit card.

[0089] EMV cards use a cryptographic engine which authenticates the card, the transaction, and the card holder each time that the card is used in a transaction. By authenticating the card, the transaction, and the card holder, EMV card transactions are more secure than magnetic stripe card transactions were the card data on the magnetic stripe can be skimmed and cloned for use in fraudulent transactions.

[0090] EMV cards can be authenticated in both online transactions and offline transactions. An online transaction is a transaction in which the terminal is connected to a card authorization service, such as a card authorization service provided by a card issuer. An offline transaction is a transaction in which the terminal is not connected to a card authorization service. In an online transaction, the EMV card is authenticated using dynamic data authentication (DDA). During a DDA session, the EMV card creates a unique digital signature for the particular transaction. The digital signature is based on a public key that is stored in the EMV card and signed by a certification authority. A random number for the particular transaction is generated by the terminal and the digital signature is changed based on the random number. The digital signature is then verified by the card authorization service using the public key. In an offline transaction, the card is authenticated by the terminal using static data authentication (SDA), DDA, or a cryptogram generation authentication (CDA) and DDA. SDA is an asymmetric digital signature scheme that uses public and private keys to encode and decode the data. The private key is only known by the card issuer, whereas the public key is known by every terminal. CDA is a dynamic signature similar to DDA where the signature is generated in the EMV card and verified by the terminal.

[0091] Transactions using EMV cards can be authenticated during transactions. Card issuers typically define the rules for authenticating transactions with their EMV cards. In an online transaction, transaction information, which similar to card data on a static magnetic stripe, along with a transaction specific cryptogram are sent to an authorization service for transaction authorization. In an offline transaction, the terminal and EMV card exchange card information and the terminal can approve or reject the transaction.

[0092] Cardholders of EMV cards can be authenticated during transactions. Card issuers typically define the rules for authenticating transactions with their EMV cards. During a transaction, a cardholder can enter a PIN into the terminal. In an online transaction, the PIN can be verified by an authorization service or at the terminal. In an offline transaction, the PIN can



be verified by the terminal. Alternatively, the cardholder can sign a receipt and the signature can be compared to a signature on the EMV card.

[0093] The level of verification that a terminal may require can depend on the amount of risk associated with the transaction. In some cases, such as in offline transactions, the terminal may limit an amount for any given transaction to protect against fraud and credit overruns.

[0094] Referring back to Figs. 10A and 10B depict an embodiment of a universal integrated circuit card 1000. The universal integrated circuit card 1000 has a front 1010 that can include an EMV chip 1011. The front of the card 1010 can also include features such as the card holder's name 1012, a display 1013, and a brand area 1014. The universal integrated circuit card 1000 also has a back 1020 that can include a dynamic magnetic stripe 1021. The back of the card 1020 can also include features such as a signature area 1022 and a brand area 1023. The universal integrated circuit card 1000 can include any or all of the features described above with respect to universal card 110. Thus, the universal integrated circuit card 1000 can communicate with a mobile device be programmed to emulate traditional magnetic stripe cards using the dynamic magnetic stripe 1021, and the universal integrated circuit card 1000 can interact with point-of-sale terminals that include magnetic stripe readers, short range transceivers, radio communication apparatuses, and the like. In addition, the EMV chip 1011 of universal integrated circuit card 1000 can be associated with a default credit or debit card. In this configuration, the universal integrated circuit card 1000 can be used with the default credit or debit card associated with the EMV chip 1011 at any terminal that requires an EMV chip and the universal integrated circuit card 1000 can be used to emulate any other card using the dynamic magnetic stripe 1021, a short range transceiver (not shown), a radio communication apparatus (not shown), or similar communication mechanism.

[0095] When a user orders or otherwise obtains a universal card 1000, the user can select or order a universal card 1000 that has an EMV chip 1011 associated with a particular default credit or debit card. The default credit or debit card associated with the EMV chip 1011 can be the same or different from a default card associated with the dynamic magnetic stripe 1021. For example, the user may have a VISA credit card that is the default card for the dynamic magnetic stripe 1021 and the same VISA credit card may be the default card associated with the EMV chip 1011. In this example, the user is accessing the same VISA credit card whether the transaction uses the EMV chip 1011 or whether the transaction uses the default card associated with the dynamic magnetic stripe 1021. In another example, the user may have a DISCOVER credit card that is the default card for the dynamic magnetic stripe 1021 and the user

may have a MASTERCARD credit card that may be the default card associated with the EMV chip 1011. This example may be ideal for a user who lives in the United States and frequently wants to use the DISCOVER credit card for purchases at magnetic swipe terminals in the United States, but also frequently travels to Europe and wants to use the MASTERCARD credit card for purchases at EMV terminals in Europe. In either example, while the EMV chip may not be dynamically programmable, the universal integrated circuit card 1000 would still be programmable to emulate other cards, such as an AMERICAN EXPRESS credit card, using the dynamic magnetic stripe 1021, a short range transceiver, or a radio communication apparatus.

[0096] Referring now to Figs. 11A and 11B, depicted is another embodiment of a universal card 1100. The universal card 1100 has a front 1110 that can optionally include a card holder's name 1111, a display 1112, and a brand area 1113. The universal card 1100 also has a back 1120 that can include a dynamic magnetic stripe 1121. The back of the card 1120 can also include features such as a signature area 1122 and a brand area 1123. The universal integrated circuit card 1100 can also include a secure element 1130, which can be located on the front, the back, or in the interior of universal integrated circuit card 1100.

[0097] A secure element 1130 is a tamper-proof smart card chip capable of embedding smart card grade applications, such as bank cards, credit cards, transportation cards, and the like, with the level of security required by financial institutions. Secure elements have been included in some computing devices, such as smart phones, as an independent part of the computing system which stores data associated with traditional cards and runs any software applications that use the traditional card data. Card issuers typically require this independent secure element to be in the computing device to ensure the security of the traditional card data and to protect against fraud. This requirement puts a limitation on developers and distributors of software application that use traditional card data because the ability to use such software applications is limited to computing devices which have secure elements. For example, a software developer may create a software application that runs in a cell phone operating system, such as the ANDROID operating system. The ANDROID operating system is available for use on a wide variety of cell phone models, only a few of which have secure element hardware. Thus, the software application will be limited to use on only those cell phone models that have a secure element and cannot be used on ANDROID cell phones that do not have a secure element.

[0098] In the embodiment depicted in Figs. 11A and 11B, the universal card 1100 includes a secure element 1130 in the card. The universal card 1100 can communicate with any computing device, regardless of whether the computing device has a secure element. In the case where the universal card is in communication with a cell phone that does not have a secure

element, the universal card 1100 can make secure element 1130 available for use by the cell phone. Thus, a user will be able to use software applications on the cell phone that require a secure element by utilizing the secure element 1130 of the universal card 1100 while the cell phone is in communication with the universal card 1100. Furthermore, the user can enter traditional card information into the cell phone while the cell phone is in communication with the universal card 1100, the traditional card data can be communicated to the secure element 1130 of the universal card 1100 for storage, and the cell phone can later access the traditional card data in the secure element 1130 of the universal card 1100 in the same or a later communication session. Including a secure element 1130 in universal card 1100 solves the issues associated with computing devices that do not have a secure element. In addition, including a secure element 1130 in universal card 1100 allows banks and card issuers to have greater control of the use of secure elements. Currently, when mobile device manufacturers include secure elements in mobile devices, banks and card issuers must negotiate with the manufacturers to be able to have access to and use of the secure element. However, moving the secure element to a universal card 1100 which is under control of the bank or card issuer eliminates the need for the bank to negotiate with the manufacturer of a mobile device to have access to a secure element regardless of whether the mobile device also has a secure element.

**[0099]** Referring now to Figs. 12A and 12B, depicted is another embodiment of a universal card 1200 having a secure element and an EMV chip. The universal card 1200 has a front 1210 that can optionally include a card holder's name 1211, a display 1212, and EMV chip 1213, and a brand area 1214. The universal card 1200 also has a back 1220 that can include a dynamic magnetic stripe 1221. The back of the card 1220 can also include features such as a signature area 1222 and a brand area 1223. The universal integrated circuit card 1200 can also include a secure element 1230.

**[0100]** Referring now to Fig. 13, depicted is an embodiment of a universal card 1300 with a power indicator 1310. The power indicator 1310 indicates to the user that the universal card 1300 is ready to be used in a transaction. The power indicator 1310 can indicate that the universal card 1300 can be used with either or both of a magnetic stripe reader and a contactless payment terminal. The power indicator 1310 can be any visual indicator, such as an LED light, a color indicator, and the like. In the embodiment of an LED light, the LED light can be illuminated when the card is active (i.e., ready to emulate a traditional card as either or both of a magnetic swipe card or a contactless payment card) and the LED light can be off when the card is inactive. A power indicator 1310 on universal card 1300 can replace the need for the universal card 1310 to have a display, thereby reducing the overall cost to make and sell the universal card

1310. As depicted in Fig. 13, the power indicator 1310 can be located on a front 1320 of universal card 1300. Optionally, the front 1320 of universal card 1300 can also include the card holder's name 1321 and a brand area 1322. In another embodiment not depicted in Fig. 13, a power indicator can be located on a back of universal card 1300.

[0101] One benefit associated with the use of a power indicator 1310 is that a card holder will know that the card is active when attempting to use the card. As discussed above, a universal card can be programmed to emulate a default card unless programmed otherwise by the card holder. In this situation, the card holder may assume that the universal card can be used at any moment as the default card. However, the universal card may be programmed to be inactive when not in use in order to conserve battery power. If the universal card is inactive and there is no power indicator, the card holder may assume that an inactive card is always active and attempt to use the inactive universal card as the default card. Having a power indicator 1310 on the universal card 1300 allows the user to easily determine whether the universal card 1300 is active and ready for use.

[0102] Referring now to Fig. 14, depicted is an embodiment of a universal card 1400 with a switch 1410. The switch 1410 enables the user to activate or deactivate the universal card 1400. Having a switch 1410 on the universal card 1400 eliminates the need for the user to interact with a mobile device in communication with the universal card 1400 to activate the universal card 1400. For example, the universal card 1400 may be programmed to emulate a default card unless programmed otherwise by the card holder. If the card holder simply wants to use the universal card 1400 to emulate the default card, the card holder can activate the universal card 1400 using the switch 1410 and not have to use a mobile device in communication with the universal card 1400 to activate the universal card 1400. The switch can be especially useful if the user's mobile device is out of battery power or otherwise malfunctioning. When the universal card 1400 is activated using the switch 1410, the universal card 1400 can retrieve the information for the default card from a secure element in universal card 1400. Thus, no exchange of information between a mobile device and universal card 1400 is necessary to activate universal card 1400 to be the default card using the switch 1410.

[0103] A bank or card issuer of a universal card may take advantage of the default card feature of the universal card. The bank or card issuer may require the consumer to download and use its e-wallet software application to interface with the universal card. That e-wallet software may require that the default card of the universal card is a default card which is issued by the bank or card issuer. For example, if a bank issues the universal card and requires the consumer to download the bank's e-wallet software, the bank's e-wallet software may allow

the consumer to select only one of the bank's cards, such as a debit card associated with the bank or a credit card associated with the bank, as the default card. In this scenario, each of the default cards associated with the universal card, including a default card for an EMV chip, a default card for a dynamic magnetic stripe, and a default card for contactless payment, may be a card associated with the bank. Arranging for all of the default cards to be associated with the bank is a valuable position for the bank because the easiest way for the consumer to use the universal card is by using the universal card as one of the default cards without using a mobile device to change the universal card to a non-default card.

[0104] The switch 1410 can take any number of forms. As depicted in Fig. 14, the switch 1410 could be a button on the exterior of universal card 1400, such as on a front 1420 of universal card 1400. Optionally, the front 1420 of universal card 1400 can also include the card holder's name 1421 and a brand area 1422. In another embodiment not depicted in Fig. 14, a switch can be located on a back of universal card 1400. In addition, the universal card 1400 could include both a switch 1410 and a power indicator (not shown in Fig. 14). This combination would allow the card holder to activate the universal card 1400 using the switch 1410 and visually see that the universal card 1400 has been activated. In another form of the switch not depicted in Fig. 14, the switch 1410 could be snap switch on the interior of the card. A snap switch can detect bending and/or tapping of the universal card 1400. Using a snap switch, in order for the card holder to activate the card, the card holder would slightly bend and/or tap the card until the universal card is active. In the embodiment of a snap switch, a power indicator on the card may be particularly helpful so that the card hold knows when the card has been sufficiently bent and/or tapped to trigger the snap switch.

[0105] Referring now to Figs. 15A and 15B, depicted are ways to add traditional card data to a secure element of a universal card. As shown in Fig. 15A, a card holder can have one or more traditional cards 1510. The user can swipe the one or more traditional cards 1510 through a magnetic stripe reader 1520 which reads the traditional card data from the swiped magnetic stripe. The magnetic stripe reader 1520 is connected to a mobile device 1530 which is configured to receive the traditional card data from the magnetic stripe reader 1520. The connection between the magnetic stripe reader 1520 and the mobile device 1530 may be a wired connection or wireless connection. The mobile device 1530 can be connected to a universal card 1540 which has a secure element 1541 via a short range communication link. The mobile device 1530 is configured to transmit the traditional card data received from the magnetic stripe reader 1520 to the universal card 1540 without storing the traditional card data, and the universal card 1540 is configured to store the traditional card data in the secure element 1541. In one

embodiment of the connection between the magnetic stripe reader 1520 and the mobile device 1530, the magnetic stripe reader 1520 has a headphone connector which is configured to connect to a headphone port of the mobile device 1530, and the mobile device 1530 is configured to receive the traditional card data from the magnetic stripe reader 1520 via the headphone port.

[0106] As shown in Fig. 15B, a computing device 1550 can store traditional card data in storage 1551. The computing device 1550 can also have a processor 1552 and other computing hardware and/or software. The computing device 1550 can be controlled and secured by a bank, by a traditional card issuer, or by another entity. The computing device 1550 is connected to a mobile device 1570 via a network 1560. The network 1560 can be a wired network, a wireless network, or any combination of wired and wireless networks, including one or more of the internet, a cellular phone network, a wi-fi network, a local area network, a wide area network, and the like. The mobile device 1570 is configured to receive the traditional card data from the computing device 1550 via the network 1560. The computing device may encrypt the traditional card data prior to transmission via the network 1560. The mobile device 1570 can be connected to a universal card 1580 which has a secure element 1581 via a short range communication link. The mobile device 1570 is configured to transmit the traditional card data received from the computing device 1550 to the universal card 1580 without storing the traditional card data, and the universal card 1580 is configured to store the traditional card data in the secure element 1581.

[0107] Another way that a secure element of a universal card can be loaded with traditional card data is by the card issuer pre-loading the traditional card data on the secure element before the card is given to the consumer. The card issuer may have information about some or all of the consumer's traditional cards and can pre-load the secure element of a card with the traditional card data. In one example, the card issuer may be a bank and the consumer may have a debit card associated with the bank and a credit card associated with the bank. The bank may pre-load into the secure element of a universal card traditional card data corresponding to each of the debit card and the credit card before sending the universal card to the consumer. When the consumer receives the card, the universal card will already be configurable to emulate the debit card and the credit card. In one embodiment, the bank may also designate one of the debit card and the credit card as the default card for the universal card before sending the universal card to the consumer. In this embodiment, the universal card may be immediately available to the consumer for use as the default card without having to interface the universal card with a mobile device. Setting the default card to a traditional card associated with the bank

gives the bank the valued position of having its traditional card be the easiest way for the consumer to use the universal card.

[0108] Referring now to Fig. 15C, depicted is a way to use a universal card with a mobile device that includes a secure element. Traditional card data 1590 can be communicated to a mobile device 1591. The traditional card data 1590 can be communicated by swiping traditional card through a magnetic stripe reader which communicates the traditional card data to mobile device 1591, similar to the depiction in Fig. 15A, or traditional card data 1590 can be communicated from a computing device to mobile device 1591 via a network, similar to the depiction in Fig. 15B. Mobile device 1591 can include a secure element 1592 which is configured to securely and independently store the traditional card data. The mobile device 1591 can be configured to send instructions to a universal card 1593 to program the universal card 1593 to emulate a traditional card. The instructions sent from the mobile device 1591 to the universal card 1593 can include confidential traditional card data from the secure element 1592 which is necessary for the universal card 1593 to emulate the traditional card. The instructions sent from the mobile device 1591 to the universal card 1593 can include instructions for the universal card to emulate either or both of a magnetic stripe of the traditional card and a contactless payment form of the traditional card.

[0109] Referring back to Fig. 1, a mobile device 100 can be configured to communicate with a universal card 110 that has a secure element 119 via a short range communication link 120. As described above, a secure element 119 is an independent part of the universal card 110 which stores data associated with traditional cards and maintains that traditional card data securely. The mobile device 100 can include e-wallet software 105 that provides a user interface which allows a user to program the universal card 110. In one embodiment, the secure element 119 of the universal card 110 stores confidential traditional card data associated with a VISA credit card and a DISCOVER credit card. The confidential traditional card data in the secure element 119 can include any information necessary to emulate the VISA credit card and the DISCOVER credit card, such as an account number, a card number, a card holder's name, an expiration date, a card verification value 2 (CVV2), information stored on the magnetic stripe of the traditional cards, and any other required information. The e-wallet software 105 may not store the confidential traditional card data because banking requirements may not permit the confidential traditional card data to be stored on the mobile device 100. However, the mobile device 100 may store non-confidential data for each of the traditional cards. For example, the mobile device 100 may store a nickname associated with each traditional card, the last 4 digits of the traditional card number, an image associated with the issuer of each

traditional card, and so forth. By storing non-confidential traditional card data in mobile device 100, the e-wallet software 105 can permit the user to select which traditional card the universal card 110 shown emulate by displaying some or all of the non-confidential traditional card data. For example, the e-wallet software 105 may display two buttons respectively labeled as "VISA \*\*\*\* \* 1234" and "DISCOVER \*\*\*\* \* 9876." The user can select either of the two traditional credit card options. In response, the mobile device 100 sends a signal to universal card 110 indicating that the universal card should emulate the selected traditional credit card. In one embodiment, the universal card 110 configures both the dynamic magnetic stripe 111 to emulate the magnetic stripe of the selected traditional credit card and the short range transceiver 116 to emulate the selected traditional credit with a contactless payment terminal. In this manner, the user needs only to select the desired traditional card using the e-wallet software 105, without having to make a selection of magnetic stripe or contactless payment, and the user can use the traditional card with either a magnetic swipe terminal or a contactless payment terminal.

[0110] When the universal card 110 is in communication with the mobile device 100, the universal card 110 may send notifications back to mobile device 100. For example, if a battery in universal card 110 is low, the universal card 110 can send a low battery signal to the mobile device 100. The mobile device 100 or the e-wallet software 105 can be configured to display a warning message to the user. The mobile device 100 or the e-wallet software 105 can also be configured to communicate to the issuer of the universal card 110 that the universal card 110 needs to be replaced. In another example of a notification, a VISA card may have been selected as a default card for the universal card 110, but the user may have programmed the universal card 110 to emulate a DISCOVER card for a three-hour period and then revert back to the default VISA card. This situation may occur when the user is planning to spend several hours at a shopping mall and wants to use the DISCOVER card while at the mall. At or near the end of the three-hour period, the universal card 110 may send a signal to the mobile device that the universal card 110 is about to revert back to the default VISA card. The mobile device 100 or the e-wallet software 105 can be configured to display a warning message or sound and alarm to the user so that the user is aware of the reversion back to the VISA card.

[0111] One issue with using a mobile device 100 to interface with a universal card 110, and any confidential data stored in a secured element of the universal card, is the need for authentication. Several forms of authentication are discussed above. Authentication may also vary based on the configuration of the mobile device 100. For example, a mobile device 100 may be secured such that a user of the mobile device must be authenticated each time the user



unlocks the mobile device 100. In this case, the e-wallet software 105 may recognize that the user has already been authenticated when the mobile device 100 was unlocked, and the e-wallet software 105 may not need to require authentication when the user initially interfaces with the e-wallet software 105. In another example, a user may be able to unlock the mobile device 100 without any authentication. In this case, any person may be able to unlock the device and start the e-wallet software 105. Here, the e-wallet software 105 may recognize that the user has not been authenticated when the mobile device 100 was unlocked, and the e-wallet software 105 may require the user to be authenticated when the user initially interfaces with the e-wallet software 105.

[0112] The issuer of the universal card 110 may have interest in making the universal card 110 available for interacting with e-wallet software created by other individuals or entities. In order to allow such third-party software to be created, the issuer may create an application programming interface (API) or software developer kit (SDK) which provides a framework of rules and specifications for interacting with the universal card 110. The API or SDK can be provided to third party software developers to enable them to create e-wallet software applications that successfully interact with the universal card 110.

[0113] The dynamic magnetic stripe 111 of universal card 110 may be used in a number of ways that are not available to static magnetic stripe cards. As discussed above, magnetic stripe cards have three standard track layouts: Track 1, Track 2, and Track 3. Various implementations of magnetic stripes have standard fields in certain tracks while leaving other portions of tracks available for other uses. Having a dynamic magnetic stripe 111 in a universal card 110 allows the non-standardized portions of the tracks to communicate data to a terminal that cannot be communicated by a static magnetic stripe of a traditional card. In one embodiment, a card holder may want to pay with a credit card and use one or more coupons in the same transaction. In a traditional setting, the card holder would present physical coupons to a cashier, the cashier would enter the coupons, and the card holder's traditional card would be swiped for payment. In contrast, an e-wallet application 105 can manage digital coupons for a user. Using the mobile device 100 and e-wallet application 105, the user can select one or more coupons to be used in a transaction, and a corresponding signal can be communicated to the universal card 110. The signal can also include an indication of a traditional card for the universal card 110 to emulate. When universal card 110 configures the dynamic stripe 111 to emulate a traditional card magnetic stripe, the universal card 110 can also include the coupon information in one of the non-standardized portions of the tracks. The universal card 110 can be swiped in a magnetic stripe reader which is configured to identify the data in the non-

standardized portions of the tracks. The magnetic stripe reader may apply the coupon to the transaction prior to charging the transaction to the account associated with the traditional card emulated by the universal card 110.

[0114] Another example of using the non-standardized portions of the tracks includes using a dynamic authentication value to authenticate the transaction. To prevent fraudulent transactions, traditional contactless cards can generate dynamic data every time they are read. Dynamic data generation per read provides logical security and inhibits fraudulent replay of contactless card data that may have been previously read. For example, contactless credit, debit and prepaid payment card data includes a dynamic card verification number, sometimes referred to "CVC," "CVV," or "dynamic CVV," or transaction certificate (for EMV cards). The dynamic authentication value is unique for every transaction. One way of the dynamic authentication value to be generated is using a secret key stored in secured memory of the card, a random number, a transaction counter, and a specific algorithm. Other ways of generating the dynamic authentication value are possible. The dynamic authentication value is generated dynamically every time a traditional contactless card is read for a transaction and the dynamic authentication value can be authenticated by a payment terminal contacting the issuer of the card to verify the dynamic authentication value. However, dynamic authentication values cannot be used with traditional static magnetic stripe cards because the static magnetic stripe cannot produce a unique dynamic authentication value each time the magnetic stripe is swiped for a transaction. The use of a dynamic magnetic stripe 111 in universal card 110 allows a dynamic authentication value unique to each transaction to be written to the non-standardized portions of the tracks. In this manner, a universal card 110 can generate a dynamic authentication value in the same manner as traditional contactless cards and write the generated dynamic authentication value to one of the non-standardized portions of the tracks. The universal card 110 can be swiped in a magnetic stripe reader which is configured to identify the dynamic authentication value in the non-standardized portions of the tracks and authenticate the transaction with the card issuer. In another embodiment, the traditional card may have a field on the static magnetic stripe for a CVV value. When the universal card is configured to emulate the traditional card that normally has a static CVV value field, the universal card may generate a dynamic authentication value and write the dynamic authentication value in the field typically used for the static CVV value. The dynamic authentication value could have the same format as the static CVV and be located in the same location that the static CVV field would be located in the static magnetic stripe of the traditional card. In this scenario, there would be no need to reconfigure the terminal with the magnetic stripe reader because it would already be configured to read a value from the static

CVV field location. Using dynamic authentication values with traditional magnetic stripe reader terminals allows for the added security of the dynamic authentication value authentication without requiring terminals to add a contactless payment terminal to the magnetic stripe reader.

[0115] When the universal card can be configured to emulate multiple traditional cards, some of issuers of the traditional cards will be capable of authenticating a dynamic authentication value while others of the issuers of the traditional cards will only be capable of authenticating a static authentication value. The secure element may store with the traditional card data, an indication as to whether a static authentication value or a dynamic authentication value should be used when emulating each traditional card.

[0116] A universal card can also be used to eliminate the need for physical traditional cards altogether. Traditional cards are currently being used as pre-paid cards in place of cash in a number of settings. Many credit issuing companies, such as VISA, MASTERCARD, and AMERICAN EXPRESS, offer pre-paid debit cards which require that the amount of the debit card be pre-paid, or "loaded," before the card can be used in a financial transaction. Some pre-paid debit cards permit users to pay up the available amount on the card, or "reload" the card. These pre-paid debit cards can be used by consumers who have bad credit but still want the ease of using a magnetic swipe card in transactions, by government agencies to provide government benefits such as social security benefits and unemployment benefits, by employers as bonuses or incentives to employees, and by consumers that give them as gifts. Traditional cards are also being used as gift cards which are typically usable only at a single retailer or group of retailers. Gift cards typically must be pre-paid. Consumers that buy gift cards must either go to a retail location to buy the physical gift card or they can purchase gift cards online and have the physical gift card shipped. Some retail locations, such as grocery stores, offer for purchase gift cards to a wide variety of other retail locations. This offers a consumer the convenience of purchasing gift cards for a number of different retailers while only physically visiting a single store to obtain the physical gift cards. Traditional cards are also being used as loyalty cards and membership cards for certain retail locations. Many retailers, such as grocery stores, allow consumers to obtain free loyalty cards which can be presented when the consumer is checking out to obtain sale prices of certain items. Other retailers, such as warehouse stores, offer paid memberships which include a membership card that must be presented each time the consumer is entering the store and/or checking out.

[0117] The proliferation of uses for traditional cards has flooded consumers with the number of traditional cards they may need to carry. For example, a consumer may carry several credit cards, a debit card, several gift cards, a membership card, and several loyalty cards.

Having to carry so many cards may reduce the likelihood that a consumer would sign up for an additional card. For example, if a consumer is at a store that offers a loyalty card, the consumer may decline the loyalty card because the consumer does not want to carry around an additional card, to remember where that card is stored in a purse or wallet during a subsequent visit to the store, and the like. Additionally, having a large number of cards increases the likelihood that a card will be misplaced, lost, or stolen. A consumer is much less likely to purchase a pre-paid card, such as a pre-paid debit card, a gift card, and the like, if the entire value of the card is lost when the card is lost, misplaced, or stolen.

[0118] Attempts have been made to eliminate the need for physical traditional cards. Services have been developed which allow consumers to make online purchases of digital gift certificates. The digital gift certificate is typically sent to the recipient in a printable form. The recipient must print out the gift certificate and take the physical printout to the retail location to use the gift certificate. The printed gift certificate typically includes a bar code or other code which the retail location can verify before accepting the printed gift certificate as payment. While this system eliminates a physical card, it still requires the consumer to carry a printout to the retail location. Additionally, loss or theft of the printout can result in loss of the value of the gift certificate if the lost or stolen printout is used by another person.

[0119] Referring now to Fig. 16, depicted is an electronic card data delivery system 1600. Computing device 1610 can be associated with an operator which distributes pre-paid cards, loyalty cards, or any other type of card. The computing device 1610 is connected, via a network 1620, to a computing device 1630. Computing device 1630 is associated with a universal card 1640. A user can contact the operator of computing device 1610 and request that card data be sent to computing device 1630 for use by universal card 1640. For example, the user can request that a \$100 gift card be sent to computing device 1630. In response to receiving the request, computing device 1610 can create a gift card account credited with \$100 and deliver, via network 1620, card data to computing device 1630. The gift card data can be used to program universal card 1640 to emulate a traditional card associated with the gift card account. In another example, the user can request a loyalty card account and computing device 1610 can deliver, via network 1620, card data to computing device 1630. The loyalty card data can be used to program universal card 1640 to emulate a traditional card associated with the loyalty card account.

[0120] Electronic delivery of card data from computing device 1610 to computing device 1630 can take a number of forms. In one example, the user requesting delivery of the card data may identify computing device 1630 and the computing device 1610 may

automatically send the card data to computing device 1630. In another example, when requesting delivery of the card data, the requester may give identification information of the recipient. The identification information may include a cell phone number of the recipient, an email address of the recipient, or any other information identifying the recipient. The computing device 1610 can send a message to the recipient by email, by text message, or by any other communication method. The message can include an indication to the recipient that card data is available for download and instructions on how the recipient can download the card data. When the recipient follows the download instructions, computing device 1630 is identified by computing device 1610 and the card data is delivered from computing device 1610 to computing device 1630. In yet another example, the delivery of card data can take place via a social network. The requester may indicate a user name or other identifier of a contact in a social network as the recipient. A message can be sent to the recipient via the social network or post a message on a page associated with the recipient. The message can include an indication to the recipient that card data is available for download and instructions on how the recipient can download the card data. When the recipient follows the download instructions, computing device 1630 is identified by computing device 1610 and the card data is delivered from computing device 1610 to computing device 1630. Any number of other examples of delivering data from computing device 1610 to computing device 1630 are possible.

[0121] Either or both of computing device 1630 and universal card 1640 can include a secure element. When computing device 1630 receives card data from the computing device 1610, it can store the card data in either a secure element of the computing device 1630, in a secure element of universal card 1640, or in secure elements of both the computing device 1630 and the universal card 1640. Once the card data is stored in a secure element, the universal card 1640 can be programmed to emulate a physical traditional card associated with the card data. It is also possible for card data to be stored in memory that is not part of a secure element. It may be advantageous to store card data associated with non-financial cards, such as loyalty cards, in memory that is outside of the secure element. Doing so may preserve limited memory capabilities of a secure element, leaving memory available in the secure element to store card data which cannot be stored outside of the secure element, such as bank card data.

[0122] The request for card data may be sent from computing device 1630. In this embodiment, a user of computing device 1630 can request card data be sent to the user's own computing device 1630. Computing device 1630 can be a cell phone, a PDA, an iPod, a tablet computer, a laptop computer, a desktop computer, an NFC-specialized device, or any other type of computing device. For example, the user may wish to add a loyalty card to the list of possible

cards that the universal card 1640 can emulate. In this case, the user can contact the loyalty card issuer using computing device 1630. Computing device 1630 can include any one of the following features which would allow the user to request card data: an e-wallet application, a card requesting application that is specifically dedicated to allowing users to request various types of card data, a retailer application that allows the user to request card data for that particular retailer, and a web browser that allows the user to access a website which allows the user to request card data. In one embodiment, the user of computing device 1630 may use an e-wallet application to request new card data. In this embodiment, the user could purchase a gift card using the e-wallet application on computing device 1630 and the remote computer 1620 could receive the request, process the purchase, and send card data for the gift card back to computing device 1630. Using the e-wallet application to purchase the gift card allows the user to select any of the cards already stored in the e-wallet application to use for purchasing the gift card. Other methods and applications are available to allow a user to request card data.

[0123] The request for card data may be sent from a computing device 1650 that is different from computing device 1630. In this embodiment, the requesting user may use any computing device 1650 which is capable of communicating a request for card data to computing device 1610. Computing device 1650 can be a cell phone, a PDA, an iPod, a tablet computer, a laptop computer, a desktop computer, an NFC-specialized device, or any other type of computing device. For example, the requesting user may wish to send a gift card to the user of computing device 1630 in electronic format so that the recipient can use the universal card 1640 to emulate the gift card. In this case, the requesting user can contact the gift card issuer using computing device 1650. In yet another example, a user can use one computing device 1650, such as a laptop computer or desktop computer, to request that card data be sent to the user's own computing device 1630, such as the user's tablet computer. Computing device 1650 can include any one of the following features which would allow the user to request card data: an e-wallet application, a card requesting application that is specifically dedicated to allowing users to request various types of card data, a retailer application that allows the user to request card data for that particular retailer, and a web browser that allows the user to access a website which allows the user to request card data.

[0124] The operator of computing device 1610 can be any number of entities. In one example, the operator of computing device 1610 can be a retailer. The retailer may operate a website through which a user can purchase products and gift cards specific to the retailer. The retailer may allow a user to purchase a gift card with delivery being in electronic form to the computing device 1630. In this case, no physical card would be sent to the requester and/or the

recipient; instead, card data would be delivered from computing device 1610 to computing device 1630 and the recipient would be able to program universal card 1640 to emulate a physical gift card. In another example, the operator of computing device 1610 can be a retailer which offers loyalty cards and/or membership cards. The retailer may allow a user to request a loyalty card or purchase a membership card with delivery being in electronic form to the computing device 1630. In this case, no physical loyalty card or membership card would be sent to the recipient because the universal card 1640 would be able to emulate a loyalty card or membership card. In another example, the operator of computing device 1610 can be a card issuer. A card issuer may allow a user to apply for a credit card. Upon approval of the credit card, the computing device 1610 can send card data to the computing device 1630 and the recipient would be able to program universal card 1640 to emulate a physical credit card. In yet another example, the operator of computing device 1610 can be a card issuer which allows users to purchase pre-paid debit cards. The card issuer may allow a user to purchase a pre-paid gift card with delivery being in electronic form to the computing device 1630. In this case, no physical pre-paid debit card would be sent to the recipient; instead, card data would be delivered from computing device 1610 to computing device 1630 and the recipient would be able to program universal card 1640 to emulate a pre-paid debit card.

[0125] In the pre-paid debit card example, the ability to request and have pre-paid debit card data delivered to a recipient electronically could obviate the need for money wiring services. In one embodiment, a parent of a college student may wish to send money to the college student. Instead of using a money wiring service, the parent may use a computing device 1650 to contact a pre-paid debit card issuer and request that a pre-paid debit card be electronically delivered to the college student's computing device 1630. Upon approval of the pre-paid debit card, the computing device 1610 can electronically deliver card data associated with the pre-paid debit card to the college student's computing device 1630. Once the card data has been electronically delivered to computing device 1630, the college student can use the pre-paid debit card by programming the universal card 1640 to emulate the pre-paid debit card. In this example, the parent was able to make money available to the college student without having to use a money wiring service and without having to ship a physical card to the college student.

[0126] The ability to send card data electronically can also improve customer loyalty reward systems. Some retailers reward customers for making purchases with loyalty cards in the form of gift cards, gift certificates, electronic gift certificates, and the like. Examples include retailers that send a gift card to customers once the customers reach some spending threshold and retailers that send electronic gift certificates to customers each month based on the amount

customers have spent during the month. These systems require either that a physical gift card or gift certificate be sent to customers, or that customers print electronic gift certificates and physically bring the printed gift certificate to the retail location. Instead, if a customer has a universal card, the customer may be able to choose to receive all benefits in the form of electronic card data. In the example where a retailer normally provides a gift card once a customer reaches some spending threshold, the retailer could send gift card data to the customer's computing device for use with the customer's universal card. Similarly, in the example where a retailer normally provides an electronic gift certificate to a customer each month based on the amount the customer has spent during the month, the retailer could send gift card data to the customer's computing device for use with the customer's universal card. In another embodiment, the retailer may be aware that the customer already has both loyalty card data for that retailer and gift card data for that retailer available for use with the universal card. In this embodiment, when the retailer is due to send a gift card or a gift certificate to the customer, the retailer may instead credit the gift card account for which the user already has the gift card data and notify the customer that the gift card account has been credited with a certain amount.

[0127] The ability to send card data electronically without having a physical card can also reduce card fraud. One way in which fraud occurs is when a thief goes to a retail location where gift cards or other cards are displayed on shelves and records the information from not-yet-activated card, sometimes referred to as "skimming." The information can include a card number, a security or access code, and the like which are sometimes concealed by cardboard or a scratch off film. The thief monitors the card status online using the card information. Once the thief finds that the card has been activated, the thief depletes the value of the card before it is used. For example, with a gift card associated with a retailer, once the gift card has been activated, the thief can go to a website of the retailer and make a purchase using the gift card information. Skimming is eliminated if card data is sent electronically to a recipient and not available for inspection in physical form.

[0128] The above description of Fig. 16 refers to computing device 1610 as a single computing device. While computing device 1610 can be a single computer, it is important to note that computing device 1610 can include multiple computing devices, such as a number of servers, multiple data centers, and the like. Computing device 1610 can also be a point of sale terminal or terminals. In this embodiment, a point of sale terminal 1610 can send card data to a computing device 1630. The gift card data can be transmitted from point of sale terminal 1610 to computing device 1630 via a network 1620, such as a wi-fi network provided by the retailer.



In one example, a user of computing device 1630 may be returning an item at the point of sale terminal 1610 and, in exchange for the return of the item, the user is entitled to a gift card with a certain amount of value. Instead of a cashier providing the user with a physical gift card, the point of sale terminal 1610 can send gift card data to the computing device 1630 where the gift card data is associated with a gift card account and is usable by the universal card 1640 to emulate the gift card. In another example, a user of computing device 1630 may wish to obtain a loyalty card while checking out at point of sale terminal 1610. Instead of a cashier providing the user with a physical loyalty card, the point of sale terminal 1610 can send loyalty card data to the computing device 1630 where the loyalty card data is usable by the universal card 1640 to emulate the loyalty card.

[0129] Referring now to Fig. 17, depicted is a method of providing card data to a universal card. A requester can send a request for card data to be sent to a recipient, as depicted by box 1710. As discussed above, the requester can send the request from a computing device to one or more computing devices associated with the card distributor via a network. In addition, the computing device used by the requester can, but need not be, associated with a universal card. The request can optionally include information identifying the recipient or the recipient's computing device. The card distributor can receive the request for card data, as depicted by box 1720. As discussed above, the request can be received by one or more computing devices associated with the card distributor via a network. The card distributor can identify a computing device associated with the recipient, as depicted by box 1730. As discussed above, identifying the recipient's computing device can include sending an email or text message to the recipient with instructions for downloading the card data. The instructions can include actions by the recipient that will identify the recipient's computing device to the card distributor. Identifying the recipient's computing device can also include information identifying the recipient's computing device in the request sent by the requester. In addition, as described above, the requester can also be the recipient. After the card distributor identifies the computing device of the recipient, the card distributor can deliver the card data to the recipient's computing device, as depicted by box 1740. As described above, the delivery can be from one or more computing devices of the card distributor to the recipient's computing device via a network. The recipient's computing device can receive the card data and store the card data in a secure element. As describe above, the secure element can be located in one or both of the recipient's computing device or a universal card associated with the recipient's computing device. The recipient can program the universal card to emulate a card using the card data delivered to the computing device associated with the recipient.

[0130] Referring now to Fig. 18, depicted are embodiments of a system and method of securely loading card data onto a universal card that has a secure element. In addition to those advantages discussed above, there are advantages to having the secure element on the universal card instead of the mobile device. A wireless carrier may assert control over access, management, and ownership of a secure element on a mobile device. Such control over the secure element may also include control over use of a short range transceiver for payments. Mobile device manufacturers and application developers can attempt to secure applications using other forms of security, such as secure elements located on SIM cards or SD cards. However, any application or data stored in a mobile device, a SIM card, or an SD card leaves the application or data susceptible to extraction, access, or inspection by thieves and/or hackers. The data on mobile devices can be read by third parties if the mobile device is lost or stolen. Users may protect their mobile device with a PIN or password; however, users frequently use only four-digit PIN numbers (a total of 10,000 possible PINs) or weak passwords that are easily overcome. If any secure card data is located on the phone, recovery of such data would allow the third party to complete transactions using the recovered phone data. Mobile devices also suffer from hacking attacks, such as phishing, Trojan, and Bot attacks. In a phishing attack, a mobile device's browser may be directed to phishing site which is configured to extract secure data from the phone or from the phone's user. In a Trojan or Bot attack, a mobile device may become infected with code which establishes a connection to a hacker's computing device and transfers secure data from the mobile device. Many other attacks on mobile devices are possible. Other attacks on mobile devices include intercepting data that is transmitted to other devices, sometimes referred to as "man-in-the-middle" attacks. When a device establishes a wireless connection, such as an NFC connection, a Bluetooth connection, or Wi-Fi connection, a third party may intercept signals sent via the wireless connection and read, modify, or reroute the data.

[0131] The system depicted in Fig. 18 prevents unencrypted secure card data from being stored on a mobile device and from being transmitted between devices. As depicted, encrypted card data 1810 can be sent to mobile device 1820. In one embodiment, the card data can be encrypted using a derived unique key per transaction (DUKPT) key management encryption scheme. In such a scheme, a one-time unique encryption key can be derived for each transaction, and the key can be generated from a master base derivation key (BDK) shared by both the encrypting entity and the decrypting entity. In one embodiment, a unique BDK can be assigned to each customer. After receiving the encrypted card data 1810, the mobile device 1820 can store the encrypted card data 1810. The encrypted data 1810 can be stored either temporarily or indefinitely without concern for the mobile device 1820 being hacked, stolen, or

otherwise compromised, as the encrypted card data 1810 can be encrypted in such a way that it is difficult or nearly impossible for the card data to be decrypted by a third party that does not have the proper key(s), such as the DUKPT and the BDK. Mobile device 1820 can include an e-wallet application 1821 and a short range transceiver 1822. The encrypted card data 1810 is unusable to the e-wallet application 1821 since the e-wallet application 1821 is unable to decrypt the encrypted card data 1810.

[0132] The mobile device 1820 can transmit the encrypted card data 1810 via the short range transceiver 1822 to universal card 1830 which also has a short range transceiver 1831. While the transmission of the encrypted card data 1810 may be made wirelessly, such as via an NFC connection, a Bluetooth connection, or other short range communication connection, such a transmission will not expose the card data to risk of being read by a man-in-the-middle attack because the card data is being transmitted as encrypted card data 1810. Even if the encrypted card data 1810 was read by a third party, it is difficult or nearly impossible for the card data to be decrypted by the intercepting party without the proper key(s). Once received via the short range transmitter 1831, the encrypted card data 1810 can be passed to secure element 1832 on the universal card 1830. The secure element 1832 can include a decrypting module 1833 which has sufficient information, such as the DUKPT and/or the BDK, to decrypt the card data. The decrypted card data can include both secure card data 1840 and non-secure card data 1850. The secure card data can include information that is typically used to ensure security of financial transactions. For example, many traditional credit and debit cards include a card certification value (CVV1) that is encoded on Track 2 of the magnetic stripe of a traditional card. During a transaction, the CVV1 value is passed to the terminal with the other card data and the terminal can verify the transaction using the CVV1 value. In the system depicted in Fig. 18, the decrypted secure card data 1840 could include the CVV1 value for a particular card. The secure card data 1840 is stored in the secure element 1832 of the universal card 1830. The universal card 1830 can be configured so that it uses the secure card data 1840 to configure dynamic magnetic stripe 1860 to emulate a static magnetic stripe of a traditional card, and the universal card 1830 can be configured so that the secure card data 1840 is stored only in secure element 1832 and not transmitted after the secure card data 1840 is decrypted. Non-secure card data 1850 can include information related to a card that would be considered acceptable if lost or stolen. Such non-secure data could include any or all of the following: the name of the issuer of the card (e.g., VISA, AMERICAN EXPRESS, etc.), the name of the card holder, the last four digits of the card number, and the expiration date of the card.

[0133] The universal card 1830 can transmit the decrypted non-secure card data 1850 to the mobile device 1820 via short range transceiver 1831. The decrypted non-secure card data 1850 can be sent to the mobile device 1820 in a batch file that can include non-secure card data for one or more cards. The mobile device 1820 can receive the non-secure card data 1850 via short range transceiver 1822 and store the non-secure card data 1850. Once stored in the mobile device 1820 stores the non-secure card data 1850, it can be used by e-wallet application 1821. E-wallet application 1821 can provide a user interface which allows a user to view the non-secure card data 1850, to manage card data and card accounts, to select a card for the universal card 1830 to emulate, to assign a nickname to a card, to assign an identifier of the type of card (e.g., VISA word account, MASTERCARD home account, etc.), choose a type of card (e.g., loyalty card, debit card, credit card), among other operations.

[0134] The system and method depicted in Fig. 18 provide a trusted environment for the secure card data 1840 and the decryption keys required for decrypting encrypted card data 1810. Using the secure element 1832 on a universal card 1830 to both decrypt encrypted card data 1810 and to store decrypted secure card data 1840 greatly reduces the possibility of fraud or theft of card data. The secure card data 1840 does not need to be transmitted off of universal card 1830 and will not be available in a decrypted form off of universal card 1830. Furthermore, mobile device 1820 will not contain any secure card data 1840 in a decrypted format. Thus, there will be no risk to the loss or theft of secure card data 1840 if mobile device 1820 is lost, stolen, or hacked.

[0135] Referring now to Figs. 19A-19C, depicted are several embodiments of systems and methods for providing card encrypted to a mobile device for transmission to a universal card with a secure element. Depicted in Fig. 19A is an encrypting card reader 1910. A user can swipe a traditional card into encrypting card reader 1910 which will read the data from the traditional card's magnetic stripe and encrypt that data as the card data is read from the traditional card's magnetic stripe to create encrypted card data 1920. In one embodiment, the encrypting card reader 1910 can use a triple data encryption standard (3DES) and DUKPT to encrypt the card data as it the data is read from the traditional card's magnetic stripe. In the embodiment depicted in Fig. 19A, the encrypting card reader 1910 can be connected directly to mobile device 1930. The connection between encrypting card reader 1910 and mobile device 1930 can be a wired connection, such as a cable connecting encrypting card reader 1910 to an audio jack of mobile device 1930, or a wireless connection, such as via a Wi-Fi network. The encrypted card data 1920 can be communicated from the encrypting card reader 1910 to the mobile device 1930 which transmits the encrypted card data 1920 to universal card 1940.

Universal card 1940 can include a secure element 1941 which has a decryption module that can decrypt encrypted card data 1920 and store decrypted secure card data. Universal card 1940 can also transmit decrypted non-secure card data back to mobile device 1930.

[0136] Depicted in Fig. 19B is an embodiment where encrypting card reader 1910 is connected to a computing device 1950. Computing device 1950 can be any computing device, such as a personal computer, a laptop computer, a tablet, and the like. A user can swipe a traditional card into encrypting card reader 1910 which will read the data from the traditional card's magnetic stripe and encrypt that data as the card data is read from the traditional card's magnetic stripe to create encrypted card data 1920. The encrypting card reader 1910 can be connected to computing device 1950 via a wired connection, such as a universal serial bus (USB) connection, or a wireless connection, such as via a Wi-Fi network. The encrypted card data 1920 can be communicated from the encrypting card reader 1910 to the computing device 1950 which transmits the encrypted card data 1920 to mobile device 1930. Mobile device 1930 can transmit the encrypted card data 1920 to universal card 1940. Universal card 1940 can include a secure element 1941 which has a decryption module that can decrypt encrypted card data 1920 and store decrypted secure card data. Universal card 1940 can also transmit decrypted non-secure card data back to mobile device 1930.

[0137] Depicted in Fig. 19C is an embodiment where a source of encrypted card data 1960 provides encrypted card data 1920 to mobile device 1930. The source of encrypted card data 1960 can be a financial institution, such as a bank, a card issuer, such as a credit card company, a point of sale terminal, such as a terminal in a store that issues loyalty cards and gift cards, or any other source of encrypted card data. The source of encrypted card data 1960 can encrypt the card data to create the encrypted card data 1920 and transmit the encrypted card data 1920 to mobile device 1930 via a network 1970. The network 1970 can be a wired network, a wireless network, or any combination of wired and wireless networks, including one or more of the internet, a cellular phone network, a Wi-Fi network, a local area network, a wide area network, and the like. The network 1970 can also include one or more computing devices. For example, a bank may send encrypted card data 1920 to a user's personal computer via the internet, and the user's personal computer can send the encrypted card data 1920 to mobile device 1930 via a wireless connection, such as a Bluetooth connection or a Wi-Fi connection. In this example, the network 1970 would include the internet, the user's personal computer, and the wireless connection between the user's personal computer and the mobile device 1930. Mobile device 1930 can transmit the encrypted card data 1920 to universal card 1940. Universal card 1940 can include a secure element 1941 which has a decryption module that can decrypt

encrypted card data 1920 and store decrypted secure card data. Universal card 1940 can also transmit decrypted non-secure card data back to mobile device 1930.

**[0138]** The encryption of card data can be used with any type of traditional card data. For example, credit card data, debit card data, loyalty card data, identification card data, building access card data, and card data of any other type of card can be encrypted before it is sent to a universal card via a mobile device. The ability to send encrypted card data to a universal card via a mobile device does not preclude the possibility that card data could be sent to a universal card via a mobile device in an unencrypted form. In certain instances, it may be difficult to securely share decryption keys with a universal card. In such instances, it may be more advantageous to send card data in a decrypted form. For example, it may not be required that electronic gift card data is encrypted for transmission to the universal card, and it may be difficult to securely pass decryption keys to the universal card from every possible retailer, electronic gift card issuer, social media site, etc., that issues electronic gift cards. Thus, it may be advantageous to transmit electronic gift card data to a universal card via a mobile device in an unencrypted format even if all other types of card data, such as credit card data, is transmitted to the universal card via the mobile device in an encrypted format.

**[0139]** Referring now to Fig. 20, depicted is an embodiment of a method of securely transferring secure card data to a universal card and non-secure card data to a mobile device. At block 2010, the card data is encrypted. In some embodiments, the encryption can be performed by a card issuer, a financial institution, an encrypting card reader, and the like. At block 2020, the encrypted card data is transmitted to a mobile device. The transmission can be performed via one or both of a wired connection and a wireless connection. At block 2030, the mobile device stores the encrypted card data. At block 2040, the mobile device transmits the encrypted card data to a universal card. In one embodiment, the transmission to the universal card is done via a short range communication link, such as an NFC communication link or a Bluetooth communication link. At block 2050, a secure element of the universal card decrypts the encrypted card data. The decrypted card data can include both secure card data and non-secure card data. As shown at block 2050, the secure element can also store the decrypted secure card data. At block 2060, the universal card transmits the decrypted, non-secure card data to the mobile device. In one embodiment, the transmission to the mobile device is done via a short range communication link, such as an NFC communication link or a Bluetooth communication link. At block 2070, an e-wallet application on the mobile device stores the decrypted non-secure card data. While the blocks depicted in Fig. 20 show an order to the steps, one of ordinary skill in the art would recognize that at least some of the steps could be performed in a

different order and the methods described herein are not limited to only the order depicted in Fig. 20.

**[0140]** Referring now to Figs. 21A and 21B, depicted are embodiments of a mobile device obtaining and using RF card data in conjunction with a universal card. Fig. 21A depicts a mobile device 2110 which has a short range transceiver 2111 and an e-wallet application 2112. Fig. 21A also depicts a contactless traditional card 2120 which has an RF interface 2121. The RF interface 2121 transmits encrypted RF card data 1930. Some point-of-sale terminals have contactless payment terminals where an RF receiver can receive the encrypted RF card data 1930 as part of a contactless payment transaction. In such a transaction, a card holder merely brings the contactless traditional card 2120 in close proximity to the contactless payment terminal at which time the encrypted RF card data 1930 is passed from the RF interface 2121 to the contactless payment terminal. In the embodiment depicted in Fig. 21A, the contactless traditional card 2120 can be brought in close proximity to or tapped to the mobile device 2110 when the mobile device is acting as a contactless payment terminal so that the encrypted RF card data 1930 is transmitted from the RF interface 2121 and received by the short range transceiver 2111 of the mobile device 2110. The mobile device 2110 can store the encrypted RF card data 1930 for later use. Since the encrypted RF card data 1930 is already fully encrypted, no further encryption is needed to protect the encrypted RF card data 1930.

**[0141]** The mobile device 2110 may also store non-secure card data associated with the RF-enabled traditional card 2120. In one embodiment, such non-secure card data can be received from a universal card which decrypts encrypted card data. More specifically, in accordance with the description above, the contactless traditional card 2120 may also have a static magnetic stripe which can be read by an encrypting card reader which transmits encrypted card data to the mobile device 2110. The mobile device 2110 can transmit the encrypted card data to a universal card which has a secure element with a decrypting module that decrypts the encrypted card data to obtain decrypted secure card data and decrypted non-secure data. The universal card can transmit the decrypted non-secure card data to the mobile device 2110 which can receive and store the decrypted non-secure data. The mobile device 2110 includes an e-wallet application 2112 which can be used to manage all of the various types of card data on the mobile device 2110. In one embodiment, the e-wallet application can be used to associate the encrypted RF card data 1930 and the non-secure card data stored on the mobile device 2110 with a single card account. For example, a user could associate encrypted RF card data 1930 and the non-secure card data stored with a card account having a nickname of "Work VISA."

[0142] Referring now to Fig. 21B, depicted is an embodiment of the actions taken by the mobile device 2110 when a particular card is selected. Using the e-wallet application 2112 on mobile device, a user can associate both encrypted RF card data 1930 and non-secure card data with a single card account. When the user wants to make a payment, the user can select the card account in the e-wallet application 2112. Upon receiving the user selection of a card account, the e-wallet application 2112 can send encrypted RF card data 1930 and an indication of the selected card 1940 to the short range transceiver 2111. The short range transceiver 2111 can use the encrypted RF card data 1930 such that the mobile device can be presented at a contactless payment terminal 2170. In this case, the mobile device 2110 acts as a contactless payment card. If universal card 2150 is in proximity to the mobile device 2110 to establish a short range communication link, the indication of the selected card 1940 is sent to a short range transceiver 2151 of universal card 2150. The universal card 2150 includes a secure element 2152 which can store secure card data 2160 which is usable to configure a dynamic data communication mechanism, such as a dynamic magnetic stripe, of the universal card 2150. Upon receiving the indication of the selected card 1940, the universal card can configure the dynamic data communication mechanism to emulate a static data communication mechanism of a traditional card. For example, if the dynamic data communication mechanism is a dynamic magnetic stripe, the universal card 2150 can be presented to a magnetic stripe payment terminal 2180 after the dynamic magnetic stripe is configured to emulate a static magnetic stripe of a traditional card. In the embodiment depicted in Fig. 21B, the user's selection of a single card account, such as the "Work VISA" nicknamed account from the example in the preceding paragraph, in the e-wallet application will enable the user to make a payment from the "Work VISA" account either using the mobile device itself with a contactless payment transaction terminal or using the dynamic data communication mechanism of the universal card if the universal card is in close enough proximity to receive the indication of the selected "Work VISA" card. Such a system can lower the complexity of making a payment for the user as the user can make a payment using either the mobile device or the universal card after making a single selection of the card account.

[0143] A universal card can also be used as a proxy card. In a proxy payment transaction—sometimes also referred to as a cloud-based payment transaction—a proxy card or information is presented to a point-of-sale (POS) terminal. The proxy card or information is not specifically tied to any one account. Instead, a proxy card server securely stores and synchronizes all of a user's card account information. When the proxy card or information is presented to the POS terminal, the POS terminal communicates, directly or indirectly, with the



proxy card server to complete the transaction using the user's card account information. Some current systems exist, but suffer from certain obstacles. For example, one system allows a user to enter a PIN number and a mobile phone number at a POS terminal. The POS terminal communicates the phone number and PIN to a proxy card server to complete the payment transaction. However, this system suffers in that it is not difficult for a person to oversee a user entering a PIN and phone number and use those same credentials in fraudulent transactions. In another example, a payment system allows a user's mobile phone to communicate proxy information to a POS terminal via an NFC connection (contactless payment). However, wide adoption of this system is difficult as most POS terminals have not been upgraded to enable a mobile phone to communicate with a contactless POS terminal via NFC. Another disadvantage is that storage of sensitive proxy card information on the mobile device may require access to a secure element on mobile device. As described above, access to a secure element on the mobile device may require contracts with device manufacturers, wireless carriers, and the like. Using a universal card as a proxy card can overcome a number of deficiencies with current systems, as is described in greater detail below.

[0144] Referring now to Fig. 22, depicted is a system and method of using a universal card as a proxy card. The system includes a proxy card server 2210, a mobile device 2220, a universal card 2230, a POS terminal 2240, and a card processing center 2250. The proxy card server 2210 can be located remotely from the mobile device 2220 and the card processing center 2250, and communication between the proxy card server 2210 and each of the mobile device 2220 and the card processing center 2250 can be done by one or more communication networks, such as the internet, cellular telephone networks, Wi-Fi networks, wired communication networks, and the like. Similarly, the POS terminal 2240 and the card processing center 2250 can be located remotely from each other and communicate via one or more communication networks.

[0145] Mobile device 2220 can store indications of a proxy card and any number of the user's card accounts that are stored by proxy card server 2210. The indications stored by the mobile device 2220 can be non-secure data so that use of a secure element on the mobile device 2220 is not required. For example, proxy card server 2210 may store information about several of the user's credit cards and the mobile device may store a nickname, the last four digits, and the expiration date of each of the credit cards. Such non-secure data can enable a user to make a selection of one of the card accounts that are stored by proxy card server 2210 without having to store secure card data on the mobile device.

[0146] A user can make a selection on the mobile device 2220 to complete a transaction using the universal card 2230 as a proxy card and a selection of the card account that will be used in the transaction. The mobile device 2220 can send 2261 proxy card data, including an indication of the proxy card and an indication of the selected card account, to the proxy card server 2210. The proxy card server 2210 can return 2262 an acknowledgement that the proxy card data was received. The mobile device 2220 can also transmit 2263 proxy card data, including an indication of the proxy card and an indication of the selected card account, to the universal card 2230. The mobile device 2220 and the universal card 2230 can be connected by way of a short range communication link, such as an NFC link or a Bluetooth link. The mobile device 2220 and/or the universal card 2230 can include a secure element that stores the data necessary to configure a dynamic data communication mechanism, such as a dynamic magnetic stripe, to pass the proxy card data to POS terminal 2240. Configuring the dynamic data communication mechanism can include writing the proxy card data to required fields of the dynamic data communication mechanism and writing an indication of the selected card account to a discretionary data field of the dynamic data communication mechanism. During a transaction, the proxy card data and the indication of the selected card can be passed 2264 from the universal card 2230 to the POS terminal 2240, such as when the universal card 2230 is swiped through POS terminal 2240 during a magnetic stripe transaction or when the universal card 2230 is tapped to the POS terminal 2240 during a contactless transaction or when the universal card 2230 is input to the POS terminal 2240 during a EMV transaction.

[0147] After receiving the proxy card data and the indication of the selected card, the POS terminal 2240 can send 2265 the proxy card data, the indication of the selected card, and transaction data to the card processing center 2250. The transaction data can include the total amount of the transaction to be processed. The card processing center 2250 can send a request 2266 for the proxy card server 2210 to authenticate the proxy card data and the indication of the selected card. After the proxy card server 2210 authenticates the proxy card data and the indication of the selected card, the proxy card server 2210 can send 2267 a response to the card processing center 2250. The card processing center 2250 can then charge the user's selected account for the total amount and send 2268 a confirmation message to the POS terminal 2240 that the amount was charged. Optionally, the proxy card server 2210 can track the purchases made by the user, including the amounts charged to each of the user's card accounts.

[0148] Referring now to Fig. 23, depicted is another embodiment of a system and method of using a universal card as a proxy card. The system includes a proxy card server 2310, a mobile device 2320, a universal card 2330, a POS terminal 2340, and a card processing center

2350. A user can make a selection on the mobile device 2320 to complete a transaction using the universal card 2330 as a proxy card and a selection of the card account that will be used in the transaction. The mobile device 2220 can send 2361 proxy card data, including an indication of the proxy card and an indication of the selected card account, to the proxy card server 2210. However, in the embodiment depicted in Fig. 23, the mobile device 2320 may not be able to connect to proxy card server 2310 or proxy card server 2310 may be unable to respond.

[0149] When mobile device 2320 does not receive a response from proxy card server 2310, it can prompt the user to enter a security code, such as a PIN or a password. The mobile device 2320 can transmit 2362 the security code and the proxy card data, including an indication of the proxy card and an indication of the selected card account, to the universal card 2330. The mobile device 2320 and the universal card 2330 can be connected by way of a short range communication link, such as an NFC link or a Bluetooth link. The mobile device 2320 and/or the universal card 2330 can include a secure element that stores the data necessary to configure a dynamic data communication mechanism, such as a dynamic magnetic stripe, to pass the proxy card data to POS terminal 2340. Configuring the dynamic data communication mechanism can include writing the proxy card data to required fields of the dynamic data communication mechanism and writing an indication of the selected card account and the security code to discretionary data fields of the dynamic data communication mechanism. During a transaction, the proxy card data, the indication of the selected card, and the security code can be passed 2363 from the universal card 2330 to the POS terminal 2340, such as when the universal card 2330 is swiped through POS terminal 2340 during a magnetic stripe transaction or when the universal card 2330 is tapped to the POS terminal 2340 during a contactless transaction or when the universal card 2230 is input to the POS terminal 2240 during a EMV transaction.

[0150] After receiving the proxy card data, the indication of the selected card, and the security code, the POS terminal 2340 can send 2364 the proxy card data, the indication of the selected card, the security code, and transaction data to the card processing center 2350. The transaction data can include the total amount of the transaction to be processed. The card processing center 2350 can send a request 2365 for the proxy card server 2310 to authenticate the proxy card data, the indication of the selected card, and the security code. After the proxy card server 2310 authenticates the proxy card data, the indication of the selected card, and the security code, the proxy card server 2310 can send 2366 a response to the card processing center 2350. The card processing center 2350 can then charge the user's selected account for the total amount and send 2367 a confirmation message to the POS terminal 2340 that the amount was charged.

Optionally, the proxy card server 2310 can track the purchases made by the user, including the amounts charged to each of the user's card accounts.

[0151] Referring now to Fig. 24, depicted is an embodiment of a method of using a universal card in a proxy card transaction. As block 2401, a user can use a mobile device to select a proxy card transaction using a universal card and to select an account for the proxy card transaction. In one embodiment, the user uses an e-wallet application on the mobile device to make the appropriate selection(s). At block 2402, the mobile device sends an indication of the proxy card and the selected account to a proxy card server. At block 2403, the mobile device determines whether an acknowledgement was received from the proxy card server. If an acknowledgement was received from the proxy card server then, at block 2404, the mobile device generates proxy card data, including indications of the proxy card and the selected account. If an acknowledgement was not received from the proxy card server then, at block 2405, the mobile device prompts the user for a security code and, at block 2406, the mobile device generates proxy card data, including the security code and indications of the proxy card and the selected account.

[0152] Regardless of whether an acknowledgement was received from the proxy card server, at block 2407, the mobile device can send the proxy card data to the universal card. At block 2408, the universal card can pass the proxy card data to the POS terminal. In one embodiment, passing the proxy card data to the POS terminal includes the universal card writing data associated with the proxy card to required fields of a dynamic magnetic stripe, writing an indication of the selected account to a discretionary data field of the dynamic magnetic stripe, and, optionally, writing the security code to a discretionary data field of the dynamic magnetic stripe. In another embodiment, passing the proxy card data to the POS terminal includes the universal card passing the proxy card data to the POS terminal via an NFC communication link. In another embodiment, passing the proxy card data to the POS terminal includes the universal card passing the proxy card data to the POS terminal via an EMV chip on the surface of the universal card. At block 2409, the POS terminal transmits transaction information and the proxy card data to a card processing system. At block 2410, the proxy card data received by the card processing system is verified. In one embodiment, the card processing system sends the proxy card data to the proxy card server and the proxy card server compares the proxy card data received from the card processing system to the proxy card data received from the mobile device. In another embodiment, the card processing system sends the proxy card data to the proxy card server and the proxy card server verifies a security code in the proxy card data. At block 2411,

the card processing system sends an authorization to the POS terminal to complete the transaction.

[0153] The use of a universal card as a proxy card has a number of benefits. A universal card that has a dynamic magnetic stripe can be accepted at a much greater number of POS terminals than those systems which rely solely on NFC-enabled contactless POS terminals. If a user's universal card is ever stolen or becomes lost, the user can store any card data, such as magnetic stripe card data, NFC/RFID card data, and EMV card data, required for the universal card to emulate a traditional card or a proxy card. In addition, the use of a universal card as a proxy card is more secure than a traditional proxy card. In one embodiment, if the universal card is ever lost or stolen, the universal card could be disabled. A universal card could be disabled by the proxy card server by the proxy card server recognizing any of the discretionary data provided by the universal card in a proxy card transaction and not authorizing those transactions. The disabling of the universal card could be initiated by the user contacting a proxy card server using a mobile device. Even if the universal card is disabled, the user could continue to make proxy card transactions using the mobile device at NFC-enabled contactless POS terminals.

[0154] The universal card can be configured such that the proxy card and a default selected account are a default card unless programmed otherwise. In the default mode, the information of the default card is stored in the secure element of the universal card and the universal card is always configured to emulate the proxy card with the default selected account, unless the user sends new instructions to the universal card to temporarily emulate another card or to change to a new default card.

[0155] Proxy cards and their associated selectable accounts can be provisioned in a number of ways. In one embodiment, data associated with a proxy card and any selectable accounts can be added to a secure element of the universal card before the universal card is first provided to the user. In this way, no proxy card data or selectable account data needs be transmitted to the universal card. In another embodiment, the user may swipe any card the user wishes to add into an encrypting card reader. As described in greater detail above, the encrypted card data can be stored in the mobile device, transmitted to the universal card, and decrypted in the universal card's secure element. After decryption, non-secure card data can be transmitted back to the mobile device. In another embodiment, as discussed in more detail above, a service provider can transmit encrypted card data to the mobile device, and the encrypted card data can be stored in the mobile device, transmitted to the universal card, and decrypted in the universal card's secure element. After decryption, non-secure card data can be transmitted back to the mobile device. In another embodiment, a proxy card server can transmit encrypted card data to

the mobile device, and the encrypted card data can be stored in the mobile device, transmitted to the universal card, and decrypted in the universal card's secure element. After decryption, non-secure card data can be transmitted back to the mobile device. In yet another embodiment, the user can manually enter card data into the mobile device. The manually entered card data can be transmitted to the universal card and stored in the secure element of the universal card.

[0156] Referring now to Figs. 25A and 25B, depicted are embodiments of universal cards for use with multiple proxy card types that each have an associated default card. Fig. 25A depicts an embodiment of a universal card 2510 that has labels 2520-1, 2520-2, . . . , 2520-N and a corresponding button 2530-1, 2530-2, . . . , 2530-N for each of the labels 2520. Labels 2520 can include an indication of a type of proxy card. Types of proxy cards can include card issuers, such as VISA, MASTERCARD, DISCOVER, AMERICAN EXPRESS, and the like, card categories, such as credit card, debit card, pre-paid card, loyalty card, gift card, and the like, a miscellaneous (or "other") category, and any other type of proxy card. When any one of buttons 2530 is selected, the corresponding proxy card type can be activated. An active proxy card type can be shown by illumination of the corresponding label 2520, by illumination of the corresponding button 2530, by illumination of a light, such as an LED light, (not shown) corresponding to the proxy card type, or by any other indication. The universal card 2510 may be configured to keep a proxy card type active for a predetermined amount of time following selection of any one of buttons 2530.

[0157] When a proxy card type of universal card 2510 is active, one or more dynamic data communication mechanisms of the universal card 2510 can be configured to pass proxy card data for the active card type to a terminal. For example, when a proxy card type of universal card 2510 is activated, one or more of a dynamic magnetic stripe (not shown) of universal card 2510 can be configured to pass proxy card data for the active card type to a terminal with a magnetic stripe reader, a dynamic EMV chip (not shown) of universal card 2510 can be configured to pass proxy card data for the active card type to an EMV-enabled terminal, and a short range communication mechanism (not shown) of universal card 2510 can be configured to pass proxy card data for the active card type to a short range communication mechanism of a terminal in a contactless transaction. The data needed to configure the one or more data communication mechanisms can be stored in a secure element (not shown) of universal card 2510 and retrieved from the secure element for configuring the one or more data communication mechanisms upon activation of a proxy card type.

[0158] Fig. 25B depicts an embodiment of a universal card 2540 that has labels 2550-1, 2550-2, . . . , 2550-N and a selection button 2560. Labels 2550 can include an indication of a

type of proxy card, similar to the labels 2520 discussed above with respect to universal card 2510 depicted in Fig. 25A. The selection button 2560 can be used to activate any one of the proxy card types indicated by labels 2550. For example, when the selection button 2560 is first pressed, the proxy card type associated with label 2550-1 can be activated. The activation of the proxy card type associated with label 2550-1 can be shown by illumination of the label 2550-1, by illumination of a light (not shown) of a light next to label 2550-1, or any other kind of indication. If the selection button is pressed again, the proxy card type associated with label 2550-2 can be activated. At that point, the activation of the proxy card type associated with label 2550-2 can be shown by illumination of the label 2550-2, by illumination of a light (not shown) of a light next to label 2550-2, or any other kind of indication. Subsequent pressing of selection button 2560 can cycle through each of the proxy card types associated with labels 2550 until reaching the proxy card type associated with label 2550-N. Activation of any proxy card types on universal card 2540 can cause one or more dynamic data communication mechanisms of universal card 2540 to be configured to pass proxy card data associated with the activated proxy card type to a terminal.

[0159] Referring now to Fig. 26, depicted is an embodiment of a system and method of using a universal card with multiple proxy card types where each of the proxy card types has an associated default card. The system in Fig. 26 includes a user 2610, a proxy card server 2620 that stores card type and account information 2621 for user 2610, a universal card 2630, a terminal 2640, and a card processing center 2650. User 2610 can interact 2661 with the card type and account information 2621 stored in proxy card server 2620. The card type and account information can include one or more card accounts for each proxy card type that can be activated on universal card 2630. For example, the universal card 2630 could include labels for each of VISA, MASTERCARD, DISCOVER, AMERICAN EXPRESS, and other. The user's accounts can include a personal VISA credit card, a corporate VISA credit card, a personal MASTERCARD debit card, a personal DISCOVER credit card, a personal AMERICAN EXPRESS credit card, a corporate AMERICAN EXPRESS credit card, a BEST BUY gift card, and a RADIO SHACK gift card. Data for each of the user's accounts can be stored in the card type and account information 2621 in proxy card server 2620. When interacting 2661 with type and account information 2621, the user 2610 can designate a default card for each card type. In the above example, the user can designate the corporate VISA credit card as the default for the VISA card type, the personal MASTERCARD debit card as the default for the MASTERCARD card type, the personal DISCOVER credit card as the default for the DISCOVER card type, the

corporate AMERICAN EXPRESS credit card as the default for the AMERICAN EXPRESS card type, and the BEST BUY gift card as the default for the other card type.

[0160] Once user 2610 has set default cards for each proxy card type, user 2610 can use universal card 2630 in a transaction. User 2610 can activate 2662 a proxy card type on universal card 2630. When the proxy card type of universal card 2630 is activated, one or more dynamic data communication mechanisms are configured to pass proxy card data for the active proxy card type to terminal 2640. During a transaction, proxy card type data corresponding to the active proxy card type can be passed 2663 from the universal card 2630 to the POS terminal 2640. Using the example from the preceding paragraph, the user 2610 may have activated 2662 the VISA proxy card type on universal card 2630. During the transaction, the universal card 2630 passes 2663 proxy card type data for the VISA proxy card type to terminal 2640.

[0161] After receiving the proxy card type data for the active card type, the terminal 2640 can send 2664 the proxy card type data and transaction data to the card processing center 2650. The transaction data can include a total amount of a transaction to be processed. The card processing center 2650 can send 2665 a request that includes the proxy card type data to the proxy card server 2620. The proxy card server 2620 can determine the active proxy card type on universal card 2630 based on the proxy card type data received from the card processing center 2650. The proxy card server 2620 can also determine the default card for the active proxy card type. Using the example from the preceding paragraphs, the proxy card server 2620 can determine that the active card type on universal card 2630 is the VISA card type based on the VISA proxy card data being sent from the card processing center 2650 to the proxy card server 2620. The proxy card server 2620 can determine that the corporate VISA credit card is the default card for the VISA card type at that particular time.

[0162] After determining the default card for the active card type, proxy card server 2620 can send 2666 a response to the card processing center 2650 that includes an indication of the default card for the active card type. Using the example above, the response can include an indication of the corporate VISA card. The card processing center 2650 can then charge an account associated with the default card for the amount of the transaction. The card processing center 2650 can send 2667 a confirmation message to the terminal 2640 that the transaction was approved.

[0163] One of the benefits of the system depicted in Fig. 26 is that the user 2610 will have quick and easy access to multiple types of card accounts using universal card 2630. Once the user 2610 has selected the default cards for the available card types on the universal card 2630, the user 2610 will be able to take the universal card 2630 to any terminal 2640, activate a



desired card type on the universal card 2630, and complete a transaction with terminal 2640 using the default card associated with the activated card type.

[0164] The proxy card server 2620 can provide a number of features for user 2610 to manage default cards in the card type and account information 2621. In one embodiment, the user 2610 can select to automatically adjust default cards for each of the proxy card types associated with universal card based on time. Using the example above, the user 2610 can designate the corporate VISA credit card as the default for the VISA card type and the corporate AMERICAN EXPRESS credit card as the default for the AMERICAN EXPRESS card type during the hours of 8:00 a.m. until 6:00 p.m. on weekdays. The user 2610 can also designate the personal VISA credit card as the default for the VISA card type and the personal AMERICAN EXPRESS credit card as the default for the AMERICAN EXPRESS card type at all other times. Setting default cards based on time in this manner may make it more likely that user 2610 uses a corporate cards during business hours and personal cards outside of business hours. In another embodiment, the user 2610 can select any type of card to be a default card for an "other" card type. For example, the default card type can be a loyalty card for a particular store, a gift card for any retailer, a keycard, or any other type of card. Allowing the user 2610 to select any type of card for an "other" card type gives the user 2610 flexibility to utilize the proxy card type function of the universal card 2630 in any way that best suits the needs of user 2610.

[0165] Referring now to Fig. 27, depicted is another embodiment of a system and method of using a universal card with multiple proxy card types where each of the proxy card types has an associated default card. The system in Fig. 27 includes a user 2710, a computing device 2720, a proxy card server 2730 that stores card type and account information 2731 for user 2710, a universal card 2740, a terminal 2750, and a card processing center 2760. User 2710 can interact 2771 with computing device 2720 to manage card type and account information 2731 in proxy card server 2730. When user 2710 enters a change to the default card for a given proxy card type on computing device 2720, the computing device 2720 can send 2772 a request for the change to be made in the card type and account information 2731 stored in proxy card server 2730. The proxy card server 2730 can make the change and send 2773 a confirmation that the change was made. Once computing device 2720 receives the confirmation, the computing device 2720 can acknowledge to the user 2710 that the change was made successfully.

[0166] Once user 2710 has set default cards for each proxy card type, user 2710 can activate a proxy card type on universal card 2740. In the embodiment depicted in Fig. 27, user 2710 can use computing device 2720 to select a proxy card type, and computing device 2720 can send 2774 instructions to universal card 2740 to activate the selected proxy card type. Once

universal card 2740 receives the instructions and activates the selected proxy card type, the universal card 2740 can provide an indication of the activated proxy card type, such as by illuminating a label associated with the activated card type. In another embodiment, the user 2710 can use a button or buttons on the universal card to activate one of the proxy card types.

[0167] When the proxy card type of universal card 2740 is activated, one or more dynamic data communication mechanisms can be configured to pass proxy card data for the active proxy card type to terminal 2750. During a transaction, proxy card type data corresponding to the active proxy card type can be passed 2775 from the universal card 2740 to the terminal 2750. After receiving the proxy card type data for the active card type, the terminal 2750 can send 2776 the proxy card type data and transaction data to the card processing center 2760. The transaction data can include a total amount of a transaction to be processed. The card processing center 2760 can send 2777 a request that includes the proxy card type data to the proxy card server 2730. The proxy card server 2730 can determine the active proxy card type on universal card 2740 based on the proxy card type data received from the card processing center 2760. The proxy card server 2730 can also determine the default for the active card type. After determining the default card for the active card type, proxy card server 2730 can send 2778 a response to the card processing center 2760 that includes an indication of the default card for the active card type. The card processing center 2760 can then charge an account associated with the default card for the amount of the transaction. The card processing center 2760 can send 2779 a confirmation message to the terminal 2750 that the transaction was approved.

[0168] Referring now to Figs. 28A and 28B, depicted are embodiments of universal cards for use with multiple proxy card types that each have an associated default card. Fig. 28A depicts an embodiment of a universal card 2810 that has labels 2820-1, 2820-2, . . . , 2820-N and a corresponding button 2830-1, 2830-2, . . . , 2830-N for each of the labels 2820. Labels 2820 can include an indication of a type of proxy card. Universal card 2810 can also include a display 2840. When any one of buttons 2830 is selected, the corresponding proxy card type can be activated. Information about the selected proxy card type—such as any or all of an indication of the selected proxy card type (e.g., “VISA”), an indication of a card number associated with the selected proxy card type, an indication of the expiration of the card number associated with the selected proxy card type, and a CVV2 value associated with the selected proxy card type—can be displayed in display 2840. Similarly, information about the default card associated with the selected proxy card type—such as any or all of an indication of the default card (e.g., “Personal VISA,” “Corporate VISA,” etc.), an indication of a card number of the default card, an indication of the expiration of the default card, and a CVV2 value of the default card—can be displayed in

display 2840. The information about the selected proxy card type and/or information about the default card associated with the selected proxy card type can be stored in a secure element (not shown) of the universal card 2810. Having a display 2840 on universal card 2810 may eliminate the need for illumination of any of labels 2820, buttons 2830, or other light to indicate which proxy card type has been selected.

**[0169]** In order for the display 2840 of universal card 2810 to be able to display information about the default card, information about changes to the default card can be communicated to the universal card 2810. For example, referring back to the system depicted in Fig. 27, user 2710 can enter a change to the default card for a given proxy card type into computing device 2720. Computing device 2720 can send 2772 a request for the change to be made in the card type and account information 2731 stored in proxy card server 2730. The proxy card server 2730 can make the change and send 2773 a confirmation that the change was made. Once computing device 2720 receives the confirmation, the computing device 2720 can send an indication to universal card 2740 of the change to the default card. In another example using the system depicted in Fig. 27, when universal card 2740 connects to computing device 2720, universal card can send a request to computing device 2720 to obtain a current listing of default cards associated with the proxy card types supported by universal card 2740. If computing device 2720 has a current listing of default cards, computing device 2720 can communicate the current listing to universal card 2740. If computing device 2720 does not have a current listing of default cards, computing device 2720 can send a request to proxy card server 2730 for the current listing, receive the current listing from proxy card server 2730, and communicate the current listing to universal card 2740.

**[0170]** A computing device can also be used as a display, similar to the way in which display 2840 of universal card 2810. For example, referring back to the system depicted in Fig. 27, a proxy card type can be activated on universal card 2740. The proxy card can be activated by selecting a button on universal card 2740 or by making a selection on computing device 2720 and communicating the selection from computing device 2720 to universal card 2740. When the selected proxy card type is activated, the universal card 2740 can send a signal to computing device 2720 to display information about the selected proxy card type and/or the default card associated with the selected proxy card type. If the information to be displayed on computing device 2720 is stored in a secure element of universal card 2740, the signal sent from universal card 2740 to computing device 2720 can include that information. Such a request to display information about the selected proxy card type and/or the default card associated with the

selected proxy card type can be sent from universal card 2740 to computing device 2720 regardless of whether universal card 2740 includes a display.

[0171] Fig. 28B depicts an embodiment of a universal card 2850 that has labels 2860-1, 2860-2, . . . , 2860-N and a selection button 2870. Labels 2860 can include an indication of a type of proxy card. The selection button 2870 can be used to activate any one of the proxy card types indicated by labels 2860 by cycling through each of the proxy card types. When the select button 2870 is pressed to active one of the proxy card types, display 2880 can display any or all of a nickname, a card number, an expiration date, a CVV2 value, or any other information about either the selected proxy card type or the default card associated with the selected proxy card type. Universal card 2850 can also interact with a computing device to obtain default card changes, to display information about a selected proxy card type and/or default card, or to perform any of the other functions described above.

[0172] Referring now to Fig. 29, depicted is another embodiment of a system and method of using a universal card with default cards stored locally on the universal card. The system in Fig. 29 includes a user 2910, a computing device 2920, a universal card 2930, a terminal 2940, and a card processing center 2950. Universal card 2930 can be configured with several selectable card types, such as VISA, AMERICAN EXPRESS, "other," and so on. Universal card 2930 can store card data for one or more cards associated with each of the card types (e.g., a personal VISA and corporate VISA associated with the VISA card type; a gift card, a loyalty card, and a key card associated with the "other" card type; etc.). Universal card 2930 can also store a default card for each of the selectable card types. For example, universal card 2930 may have a selectable VISA card type and a personal VISA card may be associated with the VISA card type when a user 2910. When user 2910 selects the VISA card type on the universal card 2930, the universal card can configure one or more dynamic data mechanism to pass card data associated with the default card to the terminal 2940. User 2910 can interact 2961 with computing device 2920 to manage card type information and default card selections that are stored locally on universal card 2930. When user 2910 enters a change on computing device 2920 to the default card selection for a card type, the computing device 2920 can send 2962 a request for the change to be made in the default card selection stored in universal card 2930. The universal card 2930 can make the change and, optionally send a confirmation back to the computing device 2920.

[0173] When the user 2910 wants to make a transaction, the user 2910 can activate a card type on universal card 2930. A card type can be activate by pressing a button on universal card 2930 or by interacting with computing device 2920 which can send a signal to universal

card 2930 to activate the selected card type. When a card type is activated, the universal card 2930 determine the default card for the selected card type. Universal card 2930 can configure one or more dynamic data communication mechanisms to pass card data for the default card to terminal 2940. Card data for one or more of the default cards can be stored in a secure element in universal card 2930. During a transaction, card data corresponding to the default card can be passed 2963 from the universal card 2930 to the terminal 2940 via the one or more dynamic data communication mechanisms. After receiving the card data for the default card, the terminal 2940 can send 2964 the default card data and transaction data to the card processing center 2950. The transaction data can include a total amount of a transaction to be processed. The card processing center 2950 can then charge an account associated with the default card for the amount of the transaction. The card processing center 2950 can send 2965 a confirmation message to the terminal 2940 that the transaction was approved.

[0174] Referring now to Figs. 30A, 30B, and 30C, depicted is an embodiment of a universal card with a dynamic EMV chip. A front of universal card 3000 is depicted in Fig. 30A with a dynamic EMV chip 3001. The dynamic EMV chip 3001 is configurable to emulate any number of static EMV chips. One embodiment of a back of universal card 3000 is depicted in Fig. 30B with a dynamic magnetic stripe 3002; however, a dynamic magnetic stripe 3002 is not required to be on a universal card 3000 that has a dynamic EMV chip 3001. Other items not picture in Figs. 30A or 30B can be located on the front or back of universal card 3000, such as a signature bar, the name of a user of the universal card, a display, a power indicator, a switch, a branding area, and other items.

[0175] One embodiment of a secure element 3003 inside of universal card 3000 is depicted in Fig. 30C. Secure element 3003 can store EMV card data 3004 for any number of EMV cards. As depicted in Fig. 30C, secure element 3003 includes EMV card data 3004<sub>1</sub> for a first card, 3004<sub>2</sub> for a second card, and 3004<sub>N</sub> for an nth card. The EMV card data 3004 for each card can include any or all of the EMV card data needed to execute both online and offline transactions, such as security credentials, cryptographic keys, DDA data, SDA data, CDA data, and cardholder verification data. The EMV card data 3004 for each card can also include and data necessary for using the EMV card in an EMV contactless transaction or an EMV contact transaction. Storing EMV card data 3004 in secure element 3003 ensures that the EMV card data 3004 cannot be extracted from universal card 3000, reducing the possibility of fraud. The EMV card data 3004 for each card can be compartmentalized and stored in separate memory blocks in secure element 2203, as is shown with respect to EMV card data 3004<sub>1</sub>, EMV card data 3004<sub>2</sub>, and 3004<sub>N</sub>. Storing EMV card data 3004 for each card in separate memory blocks in

secure element 3003 ensures that the EMV card data 3004 for one card remains isolated from any other card's credentials and maintains the security and data integrity of the EMV card data 3004 for each card. The secure element 3003 can optionally include other functionality or data, such as magnetic stripe data 3005 of one or more card accounts, card manager 3006, and card data decrypter 3007.

[0176] EMV card data can be stored in a universal card in a number of ways. In one embodiment, EMV card data can be loaded on to a universal card by the issuer of the universal card prior to the universal card being issued to the user of the universal card. For example, if a bank issues the universal card to a user, the bank could store EMV card data for any card issued by the bank, such as a bank-issued debit card, a bank-issued debit card, etc., on the universal card before the bank issued the universal card to the user. In another embodiment, depicted in Fig. 31A, a trusted source 3101 can transmit encrypted EMV card data 3102 via a network 3103 to a computing device 3104. Attached to the computing device 3104 is an EMV card reader/writer 3105 which can interface with an EMV chip on a universal card 3106. The computing device 3104 can write the encrypted card data 3102 to the universal card 3106 using the EMV card reader/writer 3105. In another embodiment, depicted in Fig. 31B, a trusted source 3111 can transmit encrypted EMV card data 3112 via a network 3113 to a computing device 3114. The computing device 3114 can be configured to communicate the encrypted EMV card data 3112 to a universal card 3115. The encrypted EMV card data 3112 can be communicated from computing device 3114 to universal card 3115 via a wired connection, such as via a USB or other serial connection, or via a wireless connection, such as an NFC communication link, a Bluetooth communication link, or other short range communication link.

[0177] Referring now to Fig. 32, depicted is an embodiment of a method of handling encrypted EMV card data by a computing device and a universal card. At block 3210, the EMV card data is encrypted. In some embodiments, the encryption can be performed by a trusted source, such as a card issuer, a financial institution, an encrypting card reader, and the like. At block 3220, the encrypted EMV card data is transmitted to a computing device. The transmission can be performed via one or both of a wired connection and a wireless connection. At block 3230, the computing device stores the encrypted EMV card data. At block 3240, the computing device transmits the encrypted EMV card data to a universal card. In one embodiment, the transmission to the universal card is done via a short range communication link, such as an NFC communication link or a Bluetooth communication link. At block 3250, a secure element of the universal card decrypts the encrypted EMV card data. The decrypted EMV card data can include both secure EMV card data and non-secure EMV card data. As

shown at block 3250, the secure element can also store the decrypted EMV secure card data. At block 3260, the universal card transmits the decrypted, non-secure EMV card data to the computing device. In one embodiment, the transmission to the computing device is done via a short range communication link, such as an NFC communication link or a Bluetooth communication link. At block 3270, an e-wallet application on the computing device stores the decrypted, non-secure EMV card data. While the blocks depicted in Fig. 32 show an order to the steps, one of ordinary skill in the art would recognize that at least some of the steps could be performed in a different order and the methods described herein are not limited to only the order depicted in Fig. 32.

[0178] Using an e-wallet application on the computing device, a user can instruct the dynamic EMV chip of the universal card to emulate a static EMV chip using the EMV card data stored in the secure element. When the user wants to make a payment, the user can select the EMV card account in the e-wallet application. Upon receiving the user selection of a card account, the e-wallet application can send an indication of the selected EMV card to a short range transceiver. The short range transceiver can send the indication of the selected EMV card to a short range transceiver of the universal card. The universal card can use the EMV card data stored in the secure element to configure a dynamic EMV chip of the universal card to emulate a static EMV chip. For example, the universal card can be presented to an EMV payment terminal after the dynamic EMV chip is configured to emulate a static EMV chip. The universal card would then act as a traditional EMV card to carry out the transaction with the EMV terminal. In one embodiment, the universal card could carry out either an online or an offline EMV transaction with the EMV terminal.

[0179] The above includes descriptions of a mobile device and a universal card. A mobile device can be any computing device, such as a mobile phone, a Personal Digital Assistants (PDA), an iPod, an MP3 player, a tablet computer, a laptop computer, a personal computer and similar mobile devices. Any of these mobile devices can have short range communication mechanisms, such as a NFC transceiver or a Bluetooth transceiver, which permits the mobile device to communicate with a universal card.

[0180] The various techniques described herein may be implemented with hardware or software or, where appropriate, with a combination of both. Thus, the methods and apparatus of the disclosed embodiments, or certain aspects or portions thereof, may take the form of program code (i.e., instructions) embodied in tangible media, such as floppy diskettes, CD-ROMs, hard drives, or any other machine-readable storage medium. When the program code is loaded into and executed by a machine, such as a computer, the machine becomes an apparatus

for practicing the disclosed embodiments. In the case of program code execution on programmable computers, the computer will generally include a processor, a storage medium readable by the processor (including volatile and non-volatile memory and/or storage elements), at least one input device and at least one output device. One or more programs are preferably implemented in a high level procedural or object oriented programming language to communicate with a computer system. However, the program(s) can be implemented in assembly or machine language, if desired. In any case, the language may be a compiled or interpreted language, and combined with hardware implementations.

[0181] The foregoing description has set forth various embodiments of the apparatus and methods via the use of diagrams and examples. While the present disclosure has been described in connection with the preferred embodiments of the various figures, it is to be understood that other similar embodiments may be used or modifications and additions may be made to the described embodiment for performing the same function of the present disclosure without deviating there from. Therefore, the present disclosure should not be limited to any single embodiment, but rather construed in breadth and scope in accordance with the appended claims. Additional features of this disclosure are set forth in the following claims.



What is Claimed:

1. A method of providing card data to a universal card for emulating a card for interacting with a terminal, wherein a transaction between the card and the terminal results in the card passing card data to the terminal, the method comprising:

receiving a request that card data be sent to a recipient computing device;

identifying the recipient computing device, wherein a universal card is associated with the recipient computing device; and

delivering, via a network, the card data to the recipient computing device, wherein the universal card is configured to emulate a card using the card data delivered to the recipient computing device.

2. The method of claim 1, wherein the card data comprises magnetic stripe data, wherein the universal card is configured to emulate a card by configuring a dynamic magnetic stripe of the universal card to pass the magnetic stripe data to a terminal.

3. The method of claim 1, wherein the card data comprises contactless data, wherein the universal card is configured to emulate a traditional card by configuring a short range transceiver of the universal card to pass the contactless data to a terminal.

4. The method of claim 1, wherein:

identifying the recipient computing device comprises receiving an indication of the recipient computing device; and

delivering the card data to the recipient computing device comprises automatically delivering the card data to the recipient computing device upon approval for the card data to be transmitted to the recipient computing device.

5. The method of claim 1, wherein:

the request that card data be sent to the recipient computing device comprises information identifying a recipient; and

identifying the recipient computing device comprises:

sending a message to the recipient based on the information identifying the recipient, the message comprising instructions to download the card data; and

identifying a computing device used by the recipient to follow the instructions to download the card data as the recipient computing device.

6. The method of claim 5, wherein the information identifying the recipient comprises an email address of the recipient and wherein sending the message to the recipient comprises sending an email to the email address.

7. The method of claim 5, wherein the information identifying the recipient comprises a phone number of the recipient and wherein sending the message to the recipient comprises sending a text message to the phone number.

8. The method of claim 5, wherein the information identifying the recipient comprises an mailing address of the recipient and wherein sending the message to the recipient comprises mailing the message to the mailing address.

9. The method of claim 1, wherein receiving the request comprises receiving the request from the recipient computing device.

10. The method of claim 1, wherein receiving the request comprises receiving the request from a requester computing device, wherein the requester computing device is different from the recipient computing device.

11. The method of claim 1, further comprising:

creating an account associated with the card data in response to receiving the request.

12. A computer readable medium having instructions embodied thereon for providing card data to a universal card for emulating a card for interacting with a terminal, wherein a transaction between the card and the terminal results in the card passing card data to the terminal, the instructions comprising:

instructions to receive a request that card data be sent to a recipient computing device;

instructions to identify the recipient computing device, wherein a universal card is associated with the recipient computing device; and

instructions to deliver, via a network, the card data to the recipient computing device, wherein the universal card is configured to emulate a card using the card data delivered to the recipient computing device.

13. The computer readable medium of claim 12, wherein the card data comprises magnetic stripe data, wherein the universal card is configured to emulate a card by configuring a dynamic magnetic stripe of the universal card to pass the magnetic stripe data to a terminal.

14. The computer readable medium of claim 12, wherein the card data comprises contactless data, wherein the universal card is configured to emulate a traditional card by configuring a short range transceiver of the universal card to pass the contactless data to a terminal.

15. The computer readable medium of claim 12, wherein:

the instructions to identify the recipient computing device comprise instructions to receive an indication of the recipient computing device; and

the instructions to deliver the card data to the recipient computing device comprise instructions to automatically deliver the card data to the recipient computing device upon approval for the card data to be transmitted to the recipient computing device.

16. The computer readable medium of claim 12, wherein:

the request that card data be sent to the recipient computing device comprises information identifying a recipient; and

the instructions to identify the recipient computing device comprise:

instructions to send a message to the recipient based on the information identifying the recipient, the message comprising instructions to download the card data; and

instructions to identify a computing device used by the recipient to follow the instructions to download the card data as the recipient computing device.

17. The computer readable medium of claim 16, wherein the information identifying the recipient comprises an email address of the recipient and wherein the instructions to send the message to the recipient comprise instructions to send an email to the email address.

18. The computer readable medium of claim 16, wherein the information identifying the recipient comprises a phone number of the recipient and wherein the instructions to send the message to the recipient comprise instructions to send a text message to the phone number.

19. The computer readable medium of claim 16, wherein the information identifying the recipient comprises an mailing address of the recipient and wherein the instructions to send the message to the recipient comprise instructions to mail the message to the mailing address.

20. The computer readable medium of claim 12, wherein the instructions to receive the request comprise instructions to receive the request from the recipient computing device.

21. The computer readable medium of claim 12, wherein the instructions to receive the request comprise instructions to receive the request from a requester computing device, wherein the requester computing device is different from the recipient computing device.

22. The computer readable medium of claim 12, the instructions further comprising:

instructions to create an account associated with the card data in response to receiving the request.

23. A system for providing card data to a universal card for emulating a traditional card for interacting with a terminal, wherein a transaction between the traditional card and the terminal results in the traditional card passing traditional card data to the terminal, the system comprising:

a communication mechanism configured to communicate via a network; and  
one or more computing devices coupled to the communication mechanism and

configured to:

receive a request that card data be sent to a recipient computing device;

identify the recipient computing device, wherein a universal card is associated with the recipient computing device; and

deliver, via the network, the card data to the recipient computing device, wherein the universal card is configured to emulate a card using the card data delivered to the recipient computing device.

24. The system of claim 23, wherein the card data comprises magnetic stripe data, wherein the universal card is configured to emulate a card by configuring a dynamic magnetic stripe of the universal card to pass the magnetic stripe data to a terminal.

25. The system of claim 23, wherein the card data comprises contactless data, wherein the universal card is configured to emulate a traditional card by configuring a short range transceiver of the universal card to pass the contactless data to a terminal.

26. The system of claim 23, wherein:

the one or more computing devices are configured to identify the recipient computing device by receiving an indication of the recipient computing device; and

the one or more computing devices are configured to deliver the card data to the recipient computing device by automatically delivering the card data to the recipient computing device upon approval for the card data to be transmitted to the recipient computing device.

27. The system of claim 23, wherein:

the request that card data be sent to the recipient computing device comprises information identifying a recipient; and

the one or more computing devices are configured to identify the recipient computing device by:

sending a message to the recipient based on the information identifying the recipient, the message comprising instructions to download the card data; and

identifying a computing device used by the recipient to follow the instructions to download the card data as the recipient computing device.

28. The system of claim 27, wherein the information identifying the recipient comprises an email address of the recipient and wherein the one or more computing devices are configured to send the message to the recipient by sending an email to the email address.

29. The system of claim 27, wherein the information identifying the recipient comprises a phone number of the recipient and wherein the one or more computing devices are configured to send the message to the recipient by sending a text message to the phone number.

30. The system of claim 27, wherein the information identifying the recipient comprises an mailing address of the recipient and wherein the one or more computing devices are configured to send the message to the recipient by mailing the message to the mailing address.

31. The system of claim 23, wherein the one or more computing devices are configured to receive the request from the recipient computing device via the network.

32. The system of claim 23, wherein the one or more computing devices are configured to receive the request from a requester computing device via the network, wherein the requester computing device is different from the recipient computing device.

33. The system of claim 23, wherein the one or more computing devices are further configured to create an account associated with the card data in response to receiving the request.

34. A method of handling card data, the method comprising:

receiving, by a computing device, card data in an encrypted format, the card data comprising secure card data and non-secure card data;

transmitting, from the computing device to a universal card, the card data in the encrypted format, wherein the universal card comprises a secure element which is configured to decrypt the card data to obtain decrypted secure card data and decrypted non-secure card data, and wherein the universal card is configured to store the decrypted secure card data in the secure element;

receiving, by the computing device from the universal card, the decrypted non-secure card data;

storing, in the computing device, the decrypted non-secure card data, wherein the computing device comprises an e-wallet application configured to permit a user selection of a card based on an identification of at least a portion of the decrypted non-secure card data; and

sending, from the computing device to the universal card, an indication of the selected card, wherein the universal card is configured to configure a dynamic data communication mechanism of the universal card to emulate a static data communication mechanism of the selected card using at least a portion of the decrypted secure card data stored in the secure element of the universal card.

35. The method of claim 34, wherein the dynamic data communication mechanism comprises at least one of a dynamic magnetic stripe and a short range transceiver.

36. The method of claim 34, wherein transmitting, from the computing device to the universal card, the card data in the encrypted format comprises transmitting the card data in the encrypted format via a short range transceiver of the computing device.

37. The method of claim 34, further comprising:

storing, by the computing device, the card data in the encrypted format after receiving the card data in the encrypted format.

38. The method of claim 34, wherein receiving the card data in the encrypted format comprises receiving, by the computing device, the card data in the encrypted format from an encrypting card reader.

39. The method of claim 34, wherein receiving the card data in the encrypted format comprises receiving, by the computing device, the card data in the encrypted format via a network.

40. A computer readable medium having instructions embodied thereon for handling card data, the instructions comprising:

instructions to receive, by a computing device, card data in an encrypted format, the card data comprising secure card data and non-secure card data;

instructions to transmit, from the computing device to a universal card, the card data in the encrypted format, wherein the universal card comprises a secure element which is configured to decrypt the card data to obtain decrypted secure card data and decrypted non-secure card data, and wherein the universal card is configured to store the decrypted secure card data in the secure element;

instructions to receive, by the computing device from the universal card, the decrypted non-secure card data;

instructions to store, in the computing device, the decrypted non-secure card data, wherein the computing device comprises an e-wallet application configured to permit a user selection of a card based on an identification of at least a portion of the decrypted non-secure card data; and

instructions to send, from the computing device to the universal card, an indication of the selected card, wherein the universal card is configured to configure a dynamic data communication mechanism of the universal card to emulate a static data communication mechanism of the selected card using at least a portion of the decrypted secure card data stored in the secure element of the universal card.

41. The computer readable medium of claim 40, wherein the dynamic data communication mechanism comprises at least one of a dynamic magnetic stripe and a short range transceiver.

42. The computer readable medium of claim 40, wherein the instructions to transmit, from the computing device to the universal card, the card data in the encrypted format comprise instructions to transmit the card data in the encrypted format via a short range transceiver of the computing device.

43. The computer readable medium of claim 40, the instructions further comprising:

instructions to store, by the computing device, the card data in the encrypted format after receiving the card data in the encrypted format.

44. The computer readable medium of claim 40, wherein the instructions to receive the card data in the encrypted format comprise instructions to receive, by the computing device, the card data in the encrypted format from an encrypting card reader.

45. The computer readable medium of claim 40, wherein the instructions to receive the card data in the encrypted format comprise instructions to receive, by the computing device, the card data in the encrypted format via a network.

46. A computing device comprising:

a short range transceiver;

an e-wallet application; and

a computer readable medium having instructions embodied thereon, the instructions

comprising:

instructions to receive card data in an encrypted format, the card data comprising secure card data and non-secure card data;



instructions to transmit, to a universal card via the short range transceiver, the card data in the encrypted format, wherein the universal card comprises a secure element which is configured to decrypt the card data to obtain decrypted secure card data and decrypted non-secure card data, and wherein the universal card is configured to store the decrypted secure card data in the secure element;

instructions to receive, from the universal card, the decrypted non-secure card data;

instructions to store the decrypted non-secure card data, wherein the e-wallet application is configured to permit a user selection of a card based on an identification of at least a portion of the decrypted non-secure card data; and

instructions to send, from the computing device to the universal card, an indication of the selected card, wherein the universal card is configured to configure a dynamic data communication mechanism of the universal card to emulate a static data communication mechanism of the selected card using at least a portion of the decrypted secure card data stored in the secure element of the universal card.

47. The computing device of claim 46, wherein the dynamic data communication mechanism comprises at least one of a dynamic magnetic stripe and a short range transceiver.

48. The computing device of claim 46, the instructions further comprising:

instructions to store the card data in the encrypted format after receiving the card data in the encrypted format.

49. The computing device of claim 46, wherein the instructions to receive the card data in the encrypted format comprise instructions to receive the card data in the encrypted format from an encrypting card reader.

50. The computing device of claim 46, wherein the instructions to receive the card data in the encrypted format comprise instructions to receive the card data in the encrypted format via a network.

51. A method of handling card data, the method comprising:

receiving, by a universal card from a computing device, card data in an encrypted format, the card data comprising secure card data and non-secure card data;

decrypting, by a decrypting module in a secure element of the universal card, the card data to obtain decrypted secure card data and decrypted non-secure card data;  
storing the decrypted secure card data in the secure element of the universal card;  
transmitting, by the universal card to the computing device, the decrypted non-secure card data, wherein the computing device comprises an e-wallet application configured to permit a user selection of a card based on an identification of at least a portion of the decrypted non-secure card data;  
receiving, by the universal card from the computing device, an indication of the selected card; and  
configuring a dynamic data communication mechanism of the universal card to emulate a static data communication mechanism of the selected card using at least a portion of the decrypted secure card data stored in the secure element.

52. The method of claim 51, wherein the dynamic data communication mechanism comprises at least one of a dynamic magnetic stripe and a short range transceiver.

53. The method of claim 51, wherein receiving, by the universal card from the computing device, the card data in the encrypted format comprises receiving the card data in the encrypted format via a short range transceiver of the universal card.

54. The method of claim 51, wherein the computing device is configured to receive the card data in the encrypted format from an encrypting card reader.

55. The method of claim 51, wherein the computing device is configured to receive the card data in the encrypted format via a network.

56. A computer readable medium having instructions embodied thereon for handling card data, the instructions comprising:

instructions to receive, by a universal card from a computing device, card data in an encrypted format, the card data comprising secure card data and non-secure card data;  
instructions to decrypt, by a decrypting module in a secure element of the universal card, the card data to obtain decrypted secure card data and decrypted non-secure card data;  
instructions to store the decrypted secure card data in the secure element of the universal card;

instructions to transmit, by the universal card to the computing device, the decrypted non-secure card data, wherein the computing device comprises an e-wallet application configured to permit a user selection of a card based on an identification of at least a portion of the decrypted non-secure card data;

instructions to receive, by the universal card from the computing device, an indication of the selected card; and

instructions to configure a dynamic data communication mechanism of the universal card to emulate a static data communication mechanism of the selected card using at least a portion of the decrypted secure card data stored in the secure element.

57. The computer readable medium of claim 56, wherein the dynamic data communication mechanism comprises at least one of a dynamic magnetic stripe and a short range transceiver.

58. The computer readable medium of claim 56, wherein the instructions to receive, by the universal card from the computing device, the card data in the encrypted format comprise instructions to receive the card data in the encrypted format via a short range transceiver of the universal card.

59. The computer readable medium of claim 56, wherein the computing device is configured to receive the card data in the encrypted format from an encrypting card reader.

60. The computer readable medium of claim 56, wherein the computing device is configured to receive the card data in the encrypted format via a network.

61. A universal card comprising:

a dynamic data communication mechanism;

a secure element comprising a decrypting module; and

a computer readable medium having instructions embodied thereon, the instructions comprising:

instructions to receive, from a computing device, card data in an encrypted format, the card data comprising secure card data and non-secure card data;

instructions to decrypt, by the decrypting module, the card data to obtain decrypted secure card data and decrypted non-secure card data;

instructions to store the decrypted secure card data in the secure element;

instructions to transmit, to the computing device, the decrypted non-secure card data, wherein the computing device comprises an e-wallet application configured to permit a user selection of a card based on an identification of at least a portion of the decrypted non-secure card data;

instructions to receive, from the computing device, an indication of the selected card; and

instructions to configure the dynamic data communication mechanism to emulate a static data communication mechanism of the selected card using at least a portion of the decrypted secure card data stored in the secure element.

62. The universal card of claim 61, wherein the dynamic data communication mechanism comprises at least one of a dynamic magnetic stripe and a short range transceiver.

63. The universal card of claim 61, the universal card further comprising:

a short range transceiver, wherein the instructions to receive, from the computing device, the card data in the encrypted format comprise instructions to receive the card data in the encrypted format via the short range transceiver.

64. The universal card of claim 61, wherein the computing device is configured to receive the card data in the encrypted format from an encrypting card reader.

65. The universal card of claim 61, wherein the computing device is configured to receive the card data in the encrypted format via a network.

66. A method of handling card data, the method comprising:

receiving, by a computing device, encrypted RF card data;

receiving, by the computing device from a universal card, non-secure card data;

storing the encrypted RF card data and the non-secure card data in the computing device;

associating the encrypted RF card data and the non-secure card data with a card account;

receiving a user selection of the card account for use as payment; and

in response to receiving the user selection of the card account for use as payment, configuring a short range transceiver of the computing device to transmit the encrypted RF card data to a contactless payment terminal and determining whether the short range transceiver can

establish a short range communication link with the universal card to transmit an indication of the selected card account to the universal card.

67. The method of claim 66, wherein the determining comprises determining that a short range communication link can be established with the universal card, the method further comprising:

transmitting, via the short range transceiver, the indication of the selected card account to the universal card.

68. The method of claim 67, wherein the universal card comprises a secure element in which secure card data associated with the selected card is stored.

69. The method of claim 68, wherein the universal card is configured to, in response to receiving the indication of the selected card, configure a dynamic data communication mechanism of the universal card to emulate a static data communication mechanism of a traditional card associated with the selected card.

70. A computer readable medium having instructions embodied thereon for handling card data, the instructions comprising:

instructions to receive, by a computing device, encrypted RF card data;

instructions to receive, by the computing device from a universal card, non-secure card data;

instructions to store the encrypted RF card data and the non-secure card data in the computing device;

instructions to associate the encrypted RF card data and the non-secure card data with a card account;

instructions to receive a user selection of the card account for use as payment; and

instructions to, in response to receiving the user selection of the card account for use as payment, configure a short range transceiver of the computing device to transmit the encrypted RF card data to a contactless payment terminal and determine whether the short range transceiver can establish a short range communication link with the universal card to transmit an indication of the selected card account to the universal card.

71. The computer readable medium of claim 70, wherein a short range communication link can be established with the universal card, the instructions further comprising:

instructions to transmit, via the short range transceiver, the indication of the selected card account to the universal card.

72. The computer readable medium of claim 71, wherein the universal card comprises a secure element in which secure card data associated with the selected card is stored.

73. The computer readable medium of claim 72, wherein the universal card is configured to, in response to receiving the indication of the selected card, configure a dynamic data communication mechanism of the universal card to emulate a static data communication mechanism of a traditional card associated with the selected card.

74. A computing device comprising:

- a short range transceiver;

- an e-wallet application; and

- a computer readable medium having instructions embodied thereon, the instructions comprising:

- instructions to receive encrypted RF card data;

- instructions to receive, from a universal card, non-secure card data;

- instructions to store the encrypted RF card data and the non-secure card data in the computing device;

- instructions to associate the encrypted RF card data and the non-secure card data with a card account;

- instructions to receive, via the e-wallet application, a user selection of the card account for use as payment; and

- instructions to, in response to receiving the user selection of the card account for use as payment, configure the short range transceiver to transmit the encrypted RF card data to a contactless payment terminal and determine whether the short range transceiver can establish a short range communication link with the universal card to transmit an indication of the selected card account to the universal card.

75. The computing device of claim 74, wherein a short range communication link can be established with the universal card, the instructions further comprising:

- instructions to transmit, via the short range transceiver, the indication of the selected card account to the universal card.

76. The computing device of claim 75, wherein the universal card comprises a secure element in which secure card data associated with the selected card is stored.

77. The computing device of claim 76, wherein the universal card is configured to, in response to receiving the indication of the selected card, configure a dynamic data communication mechanism of the universal card to emulate a static data communication mechanism of a traditional card associated with the selected card.

78. A method of initiating a proxy card transaction, the method comprising:

receiving, by a computing device, a request to use a universal card as a proxy card and a selection of a selected account;

generating, by the computing device, proxy card data comprising an indication of the proxy card and an indication of the selected account;

transmitting, from the computing device to a proxy card server, the proxy card data;

transmitting, from the computing device to the universal card, the proxy card data, wherein the universal card comprises a dynamic data communication mechanism and a secure element, and wherein the universal card is configured to configure a dynamic data communication mechanism of the universal card to emulate a static data communication mechanism of a proxy card using at least a portion of data stored in the secure element;

wherein the dynamic data communication mechanism of the universal card is configured to pass data indicative of the proxy card and the selected account to a terminal during a transaction with the terminal.

79. The method of claim 78, further comprising:

receiving, by the mobile device from the proxy card server, an acknowledgment that the proxy card server received the proxy card data;

wherein the computing device is configured to send the proxy card data to the universal card in response to receiving the acknowledgment.

80. The method of claim 78, further comprising:

determining that the mobile device did not receive an acknowledgement from the proxy card server; and

prompting a user for a security code;

wherein transmitting the proxy card data to the universal card comprises transmitting the proxy card data and the security code to the universal card.

81. The method of claim 78, wherein the dynamic data communication mechanism comprises a dynamic magnetic stripe.

82. The method of claim 81, wherein the universal card is configured to configure a dynamic data communication mechanism of the universal card to emulate a static data communication mechanism of a proxy card by writing data indicative of the proxy card to one or more required fields of the dynamic magnetic stripe and by writing an indication of the selected account to one or more discretionary data field of the dynamic magnetic stripe.

83. The method of claim 82, wherein the universal card is further configured to configure a dynamic data communication mechanism of the universal card to emulate a static data communication mechanism of a proxy card by writing an indication of a security code to the one or more discretionary data field of the dynamic magnetic stripe.

84. The method of claim 78, wherein the dynamic data communication mechanism comprises one or more of a near field communication mechanism, a radio frequency identification communication mechanism, or an EMV communication mechanism.

85. A computer readable medium having instructions embodied thereon for initiating a proxy card transaction, the instructions comprising:

instructions to receive, by a computing device, a request to use a universal card as a proxy card and a selection of a selected account;

instructions to generate, by the computing device, proxy card data comprising an indication of the proxy card and an indication of the selected account;

instructions to transmit, from the computing device to a proxy card server, the proxy card data;

instructions to transmit, from the computing device to the universal card, the proxy card data, wherein the universal card comprises a dynamic data communication mechanism and a secure element, and wherein the universal card is configured to configure a dynamic data communication mechanism of the universal card to emulate a static data communication mechanism of a proxy card using at least a portion of data stored in the secure element;



wherein the dynamic data communication mechanism of the universal card is configured to pass data indicative of the proxy card and the selected account to a terminal during a transaction with the terminal.

86. The computer readable medium of claim 85, the instructions further comprising:

instructions to receive, by the mobile device from the proxy card server, an acknowledgment that the proxy card server received the proxy card data;

wherein the computing device is configured to send transmit the proxy card data to the universal card in response to receiving the acknowledgment.

87. The computer readable medium of claim 85, the instructions further comprising:

instructions to determine that the mobile device did not receive an acknowledgement from the proxy card server; and

instructions to prompt a user for a security code;

wherein the instructions to transmit the proxy card data to the universal card comprise instructions to transmit the proxy card data and the security code to the universal card.

88. The computer readable medium of claim 85, wherein the dynamic data communication mechanism comprises a dynamic magnetic stripe.

89. The computer readable medium of claim 88, wherein the universal card is configured to configure a dynamic data communication mechanism of the universal card to emulate a static data communication mechanism of a proxy card by writing data indicative of the proxy card to one or more required fields of the dynamic magnetic stripe and by writing an indication of the selected account to one or more discretionary data field of the dynamic magnetic stripe.

90. The computer readable medium of claim 89, wherein the universal card is further configured to configure a dynamic data communication mechanism of the universal card to emulate a static data communication mechanism of a proxy card by writing an indication of a security code to the one or more discretionary data field of the dynamic magnetic stripe.

91. The computer readable medium of claim 85, wherein the dynamic data communication mechanism comprises one or more of a near field communication mechanism, a radio frequency identification communication mechanism, or an EMV communication mechanism.

92. A computing device comprising:

a short range transceiver;

an user interface; and

a computer readable medium having instructions embodied thereon, the instructions comprising:

instructions to receive, via the user interface, a request to use a universal card as a proxy card and a selection of a selected account,

instructions to generate proxy card data comprising an indication of the proxy card and an indication of the selected account,

instructions to transmit, to a proxy card server, the proxy card data, and

instructions to transmit, to the universal card via the short range transceiver, the proxy card data, wherein the universal card comprises a dynamic data communication mechanism and a secure element, and wherein the universal card is configured to configure a dynamic data communication mechanism of the universal card to emulate a static data communication mechanism of a proxy card using at least a portion of data stored in the secure element;

wherein the dynamic data communication mechanism of the universal card is configured to pass data indicative of the proxy card and the selected account to a terminal during a transaction with the terminal.

93. The computing device of claim 92, the instructions further comprising:

instructions to receive, from the proxy card server, an acknowledgment that the proxy card server received the proxy card data;

wherein the computing device is configured to send transmit the proxy card data to the universal card in response to receiving the acknowledgment.

94. The computing device of claim 92, the instructions further comprising:

instructions to determine that the mobile device did not receive an acknowledgement from the proxy card server; and

instructions to prompt a user for a security code;

wherein the instructions to transmit the proxy card data to the universal card comprise instructions to transmit the proxy card data and the security code to the universal card.

95. The computing device of claim 92, wherein the dynamic data communication mechanism comprises a dynamic magnetic stripe.

96. The computing device of claim 95, wherein the universal card is configured to configure a dynamic data communication mechanism of the universal card to emulate a static data communication mechanism of a proxy card by writing data indicative of the proxy card to one or more required fields of the dynamic magnetic stripe and by writing an indication of the selected account to one or more discretionary data field of the dynamic magnetic stripe.

97. The computing device of claim 96, wherein the universal card is further configured to configure a dynamic data communication mechanism of the universal card to emulate a static data communication mechanism of a proxy card by writing an indication of a security code to the one or more discretionary data field of the dynamic magnetic stripe.

98. The computing device of claim 92, wherein the dynamic data communication mechanism comprises one or more of a near field communication mechanism, a radio frequency identification communication mechanism, or an EMV communication mechanism.

99. A method of disabling a universal card from being used as a proxy card, the method comprising:

receiving, by a proxy card server from a first computing device, a request to disable a universal card from being used as a proxy card;

receiving, by the proxy card server from a second computing device, a request to authorize a first payment transaction, wherein the request to authorize the first payment transaction comprises data passed from the universal card to a terminal during the first payment transaction;

determining, by the proxy card server, that the data in the request to authorize the first payment transaction is associated with the universal card; and

transmitting, from the proxy card server to the second computing device, an indication that the first payment transaction is unauthorized.

100. The method of claim 99, wherein the terminal comprises the second computing device.

101. The method of claim 99, wherein a card processing center comprises the second computing device.

102. The method of claim 99, further comprising:

receiving, by the proxy card server from the second computing device, a request to authorize a second payment transaction, wherein the request to authorize the second payment transaction comprises data passed from the first computing device to the terminal during the second payment transaction;

determining, by the proxy card server, that the data in the request to authorize the second payment transaction is not associated with the universal card; and

transmitting, from the proxy card server to the second computing device, an indication that the second payment transaction is authorized.

103. A computer readable medium having instructions embodied thereon for disabling a universal card from being used as a proxy card, the instructions comprising:

instructions to receive, by a proxy card server from a first computing device, a request to disable a universal card from being used as a proxy card;

instructions to receive, by the proxy card server from a second computing device, a request to authorize a first payment transaction, wherein the request to authorize the first payment transaction comprises data passed from the universal card to a terminal during the first payment transaction;

instructions to determine, by the proxy card server, that the data in the request to authorize the first payment transaction is associated with the universal card; and

instructions to transmit, from the proxy card server to the second computing device, an indication that the first payment transaction is unauthorized.

104. The computer readable medium of claim 103, wherein the terminal comprises the second computing device.

105. The computer readable medium of claim 103, wherein a card processing center comprises the second computing device.

106. The computer readable medium of claim 103, the instructions further comprising:

instructions to receive, by the proxy card server from the second computing device, a request to authorize a second payment transaction, wherein the request to authorize the second payment transaction comprises data passed from the first computing device to the terminal during the second payment transaction;

instructions to determine, by the proxy card server, that the data in the request to authorize the second payment transaction is not associated with the universal card; and

instructions to transmit, from the proxy card server to the second computing device, an indication that the second payment transaction is authorized.

107. A computing system comprising:

a communication mechanism configured to communication with a first computing device and a second computing device via one or more networks; and

a computer readable medium having instructions embodied thereon, the instructions comprising:

instructions to receive, from the first computing device via the communication mechanism, a request to disable a universal card from being used as a proxy card;

instructions to receive, from the second computing device via the communication mechanism, a request to authorize a first payment transaction, wherein the request to authorize the first payment transaction comprises data passed from the universal card to a terminal during the first payment transaction;

instructions to determine, by the computing system, that the data in the request to authorize the first payment transaction is associated with the universal card; and

instructions to transmit, to the second computing device via the communication mechanism, an indication that the first payment transaction is unauthorized.

108. The computing system of claim 107, wherein the terminal comprises the second computing device.

109. The computing system of claim 107, wherein a card processing center comprises the second computing device.

110. The computing system of claim 107, the instructions further comprising:

instructions to receive, from the second computing device via the communication mechanism, a request to authorize a second payment transaction, wherein the request to

authorize the second payment transaction comprises data passed from the first computing device to the terminal during the second payment transaction;

instructions to determine, by the computing system, that the data in the request to authorize the second payment transaction is not associated with the universal card; and

instructions to transmit, to the second computing device via the communication mechanism, an indication that the second payment transaction is authorized.

111. A method of initiating a proxy card transaction using one of a plurality of proxy card types, the method comprising:

receiving, by a universal card, an indication of a selected proxy card type from the plurality of proxy card types;

activating, by the universal card, the selected proxy card type, wherein activating the selected proxy card type comprises configuring one or more dynamic data communication mechanisms of the universal card to be able to pass proxy card data associated with the selected proxy card type;

passing, via the one or more dynamic data communication mechanisms, the proxy card data associated with the selected proxy card type from the universal card to a terminal;

wherein the terminal is configured to transmit the proxy card data and an amount to one or more remote computing device, wherein the one or more remote computing devices are configured to determine a default card associated with proxy card data and charge the amount to an account associated with the default card.

112. The method of claim 111, wherein activating the selected proxy card type further comprises:

illuminating one or more of a label, a button, and a light on the universal card to indicate the selected proxy card type.

113. The method of claim 111, wherein activating the selected proxy card type further comprises:

displaying, on a display of the universal card, an indication of one or more of the selected proxy card type and the default card.

114. The method of claim 113, wherein the indication comprises one or more of the group consisting of a nickname of the selected proxy card type, a card number of the selected proxy

card type, an expiration of the selected proxy card type, a CVV2 value of the selected proxy card type, a nickname of the default card, a card number of the default card, an expiration of the default card, and a CVV2 value of the default card.

115. The method of claim 111, wherein activating the selected proxy card type further comprises:

    sending a request from the universal card to a computing device to display, on the computing device, an indication of one or more of the selected proxy card type and the default card.

116. The method of claim 111, wherein receiving the indication of the selected proxy card type comprises:

    detecting that one or more buttons on the universal card has been pressed.

117. The method of claim 111, wherein receiving the indication of the selected proxy card type comprises:

    receiving, by the universal card from a computing device, an indication of a selection of the selected proxy card type.

118. The method of claim 111, wherein the one or more remote computing devices comprise a proxy card server and a card processing center server.

119. The method of claim 118, wherein:

    the card processing center server is configured to receive the proxy card data and the amount from the terminal and to communicate the proxy card data to the proxy card server;

    the proxy card server is configured to determine the default card based on the proxy card data and to communicate an indication of the default card to the card processing center server;  
and

    the card processing center server is further configured to charge the amount to an account associated with the default card and to send an approval message to the terminal.

120. The method of claim 111, wherein the dynamic data communication mechanism comprises one or more of a dynamic magnetic stripe, a near field communication mechanism, a radio frequency identification communication mechanism, or an EMV communication mechanism.

121. A computer readable medium having instructions embodied thereon for initiating a proxy card transaction using one of a plurality of proxy card types, the instructions comprising:

instructions to receive, by a universal card, an indication of a selected proxy card type from the plurality of proxy card types;

instructions to activate, by the universal card, the selected proxy card type, wherein the instructions to activate the selected proxy card type comprise instructions to configure one or more dynamic data communication mechanisms of the universal card to be able to pass proxy card data associated with the selected proxy card type;

instructions to pass, via the one or more dynamic data communication mechanisms, the proxy card data associated with the selected proxy card type from the universal card to a terminal;

wherein the terminal is configured to transmit the proxy card data and an amount to one or more remote computing device, wherein the one or more remote computing devices are configured to determine a default card associated with proxy card data and charge the amount to an account associated with the default card.

122. The computer readable medium of claim 121, wherein the instructions to activate the selected proxy card type further comprise:

instructions to illuminate one or more of a label, a button, and a light on the universal card to indicate the selected proxy card type.

123. The computer readable medium of claim 121, wherein the instructions to activate the selected proxy card type further comprise:

instructions to display, on a display of the universal card, an indication of one or more of the selected proxy card type and the default card.

124. The computer readable medium of claim 123, wherein the indication comprises one or more of the group consisting of a nickname of the selected proxy card type, a card number of the selected proxy card type, an expiration of the selected proxy card type, a CVV2 value of the selected proxy card type, a nickname of the default card, a card number of the default card, an expiration of the default card, and a CVV2 value of the default card.

125. The computer readable medium of claim 121, the instructions to activate the selected proxy card type further comprise:



instructions to send a request from the universal card to a computing device to display, on the computing device, an indication of one or more of the selected proxy card type and the default card.

126. A universal card comprising:

one or more dynamic data communication mechanisms; and

a secure element configured to store proxy card data associated with each of a plurality of proxy card types;

wherein the universal card is configured to:

receive an indication of a selected proxy card type from the plurality of proxy card types,

activate the selected proxy card type, wherein activating the selected proxy card type comprises configuring the one or more dynamic data communication mechanisms of the universal card to be able to pass proxy card data associated with the selected proxy card type, and

pass, via the one or more dynamic data communication mechanisms, the proxy card data associated with the selected proxy card type from the universal card to a terminal,

wherein the terminal is configured to transmit the proxy card data and an amount to one or more remote computing device, wherein the one or more remote computing devices are configured to determine a default card associated with proxy card data and charge the amount to an account associated with the default card.

127. The universal card of claim 126, wherein activating the selected proxy card type further comprises:

illuminating one or more of a label, a button, and a light on the universal card to indicate the selected proxy card type.

128. The universal card of claim 126, wherein activating the selected proxy card type further comprises:

displaying, on a display of the universal card, an indication of one or more of the selected proxy card type and the default card.

129. The universal card of claim 128, wherein the indication comprises one or more of the group consisting of a nickname of the selected proxy card type, a card number of the selected proxy

card type, an expiration of the selected proxy card type, a CVV2 value of the selected proxy card type, a nickname of the default card, a card number of the default card, an expiration of the default card, and a CVV2 value of the default card.

130. The universal card of claim 126, wherein activating the selected proxy card type further comprises:

    sending a request from the universal card to a computing device to display, on the computing device, an indication of one or more of the selected proxy card type and the default card.

131. A method of initiating a card transaction using one of a plurality of card types, the method comprising:

    receiving, by a universal card, an indication of a selected card type from the plurality of card types;

    activating, by the universal card, the selected card type, wherein activating the selected card type comprises:

        determining a default card associated with the selected card type, and  
        configuring one or more dynamic data communication mechanisms of the universal card to be able to pass card data associated with the default card; and

    passing, via the one or more dynamic data communication mechanisms, the card data associated with the default card from the universal card to a terminal;

    wherein the terminal is configured to perform a transaction using the default card data.

132. The method of claim 131, wherein activating the selected card type further comprises:

    illuminating one or more of a label, a button, and a light on the universal card to indicate the selected card type.

133. The method of claim 131, wherein activating the selected card type further comprises:

    displaying, on a display of the universal card, an indication of one or more of the selected card type and the default card.

134. The method of claim 133, wherein the indication comprises one or more of the group consisting of a nickname of the selected card type, a card number of the selected card type, an expiration of the selected card type, a CVV2 value of the selected card type, a nickname of the

default card, a card number of the default card, an expiration of the default card, and a CVV2 value of the default card.

135. A computer readable medium having instructions embodied thereon for initiating a card transaction using one of a plurality of card types, the instructions comprising:

instructions to receive, by a universal card, an indication of a selected card type from the plurality of card types;

instructions to activate, by the universal card, the selected card type, wherein the instructions to activate the selected card type comprise:

instructions to determine a default card associated with the selected card typed,  
and

instructions to configure one or more dynamic data communication mechanisms of the universal card to be able to pass card data associated with the default card; and

instructions to pass, via the one or more dynamic data communication mechanisms, the card data associated with the default card from the universal card to a terminal;

wherein the terminal is configured to perform a transaction using the default card data.

136. The computer readable medium of claim 135, wherein the instructions to activate the selected card type further comprise:

instructions to illuminate one or more of a label, a button, and a light on the universal card to indicate the selected card type.

137. The computer readable medium of claim 135, wherein the instructions to activate the selected card type further comprise:

instructions to display, on a display of the universal card, an indication of one or more of the selected card type and the default card.

138. The method of claim 137, wherein the indication comprises one or more of the group consisting of a nickname of the selected card type, a card number of the selected card type, an expiration of the selected card type, a CVV2 value of the selected card type, a nickname of the default card, a card number of the default card, an expiration of the default card, and a CVV2 value of the default card.

139. A universal card comprising:

one or more dynamic data communication mechanisms; and  
a secure element configured to store card data associated with one or more default cards,  
wherein each of the one or more default cards is associated with one of a plurality of card types;  
wherein the universal card is configured to:  
    receive an indication of a selected card type from the plurality of card types,  
    activate the selected card type, wherein activating the selected card type  
comprises determining a default card associated with the selected card type and configuring one  
or more dynamic data communication mechanisms of the universal card to be able to pass card  
data associated with the default card,  
    pass, via the one or more dynamic data communication mechanisms, the card data  
associated with the default card from the universal card to a terminal,  
    wherein the terminal is configured to perform a transaction using the default card  
data.

140. The universal card of claim 139, wherein activating the selected card type further  
comprises:

    illuminating one or more of a label, a button, and a light on the universal card to indicate  
the selected card type.

141. The universal card of claim 139, wherein activating the selected card type further  
comprises:

    displaying, on a display of the universal card, an indication of one or more of the selected  
card type and the default card.

142. The universal card of claim 31, wherein the indication comprises one or more of the group  
consisting of a nickname of the selected card type, a card number of the selected card type, an  
expiration of the selected card type, a CVV2 value of the selected card type, a nickname of the  
default card, a card number of the default card, an expiration of the default card, and a CVV2  
value of the default card.

143. A method of handling card data, the method comprising:

    receiving, by a computing device, EMV card data in an encrypted format;  
    transmitting, from the computing device to a universal card, the EMV card data in the  
encrypted format, wherein the universal card comprises a secure element which is configured to

decrypt the EMV card data, and wherein the universal card is configured to store the decrypted EMV card data in the secure element;

receiving, by the computing device from the universal card, non-secure EMV card data;

storing, in the computing device, the non-secure EMV card data, wherein the computing device comprises an e-wallet application configured to permit a user selection of an EMV card based on an identification of at least a portion of the non-secure EMV card data; and

sending, from the computing device to the universal card, an indication of the selected card, wherein the universal card is configured to configure a dynamic EMV chip of the universal card to emulate a static EMV chip of the selected card using at least a portion of the decrypted EMV card data stored in the secure element of the universal card.

144. The method of claim 143, wherein transmitting, from the computing device to the universal card, the EMV card data in the encrypted format comprises transmitting the EMV card data in the encrypted format via a short range transceiver of the computing device.

145. The method of claim 143, further comprising:

storing, by the computing device, the EMV card data in the encrypted format after receiving the EMV card data in the encrypted format.

146. The method of claim 143, wherein receiving the EMV card data in the encrypted format comprises receiving, by the computing device, the EMV card data in the encrypted format from a trusted source.

147. The method of claim 143, wherein receiving the EMV card data in the encrypted format comprises receiving, by the computing device, the EMV card data in the encrypted format via a network.

148. The method of claim 143, wherein the EMV card data comprises one or more of gift card data, prepaid card data, and stored value card data, and wherein the selected card is associated with one of the one of the gift card data, the prepaid card data, and the stored value card data.

149. A computer readable medium having instructions embodied thereon for handling card data, the instructions comprising:

instructions to receive, by a computing device, EMV card data in an encrypted format;

instructions to transmit, from the computing device to a universal card, the EMV card data in the encrypted format, wherein the universal card comprises a secure element which is configured to decrypt the EMV card data, and wherein the universal card is configured to store the decrypted EMV card data in the secure element;

instructions to receive, by the computing device from the universal card, non-secure EMV card data;

instructions to store, in the computing device, the non-secure EMV card data, wherein the computing device comprises an e-wallet application configured to permit a user selection of an EMV card based on an identification of at least a portion of the non-secure EMV card data; and

instructions to send, from the computing device to the universal card, an indication of the selected card, wherein the universal card is configured to configure a dynamic EMV chip of the universal card to emulate a static EMV chip of the selected card using at least a portion of the decrypted EMV card data stored in the secure element of the universal card.

150. The computer readable medium of claim 149, wherein the instructions to transmit, from the computing device to the universal card, the EMV card data in the encrypted format comprise instructions to transmit the EMV card data in the encrypted format via a short range transceiver of the computing device.

151. The computer readable medium of claim 149, the instructions further comprising:

instructions to store, by the computing device, the EMV card data in the encrypted format after receiving the EMV card data in the encrypted format.

152. The computer readable medium of claim 149, wherein the instructions to receive the EMV card data in the encrypted format comprise instructions to receive, by the computing device, the EMV card data in the encrypted format from a trusted source.

153. The computer readable medium of claim 149, wherein the instructions to receive the EMV card data in the encrypted format comprise instructions to receive, by the computing device, the EMV card data in the encrypted format via a network.

154. The computer readable medium of claim 149, wherein the EMV card data comprises one or more of gift card data, prepaid card data, and stored value card data, and wherein the selected

card is associated with one of the one of the gift card data, the prepaid card data, and the stored value card data.

155. A computing device comprising:

a short range transceiver;

an e-wallet application; and

a computer readable medium having instructions embodied thereon, the instructions comprising:

instructions to receive EMV card data in an encrypted format;

instructions to transmit, to a universal card via the short range transceiver, the EMV card data in the encrypted format, wherein the universal card comprises a secure element which is configured to decrypt the EMV card data, and wherein the universal card is configured to store the decrypted EMV card data in the secure element;

instructions to receive, from the universal card, non-secure EMV card data;

instructions to store the non-secure EMV card data, wherein the e-wallet application is configured to permit a user selection of a card based on an identification of at least a portion of the non-secure EMV card data; and

instructions to send, from the computing device to the universal card, an indication of the selected card, wherein the universal card is configured to configure a dynamic EMV chip of the universal card to emulate a static EMV chip of the selected card using at least a portion of the decrypted EMV card data stored in the secure element of the universal card.

156. The computing device of claim 155, the instructions further comprising:

instructions to store the EMV card data in the encrypted format after receiving the EMV card data in the encrypted format.

157. The computing device of claim 155, wherein the instructions to receive the EMV card data in the encrypted format comprise instructions to receive the EMV card data in the encrypted format from a trusted source.

158. The computing device of claim 155, wherein the instructions to receive the EMV card data in the encrypted format comprise instructions to receive the EMV card data in the encrypted format via a network.

159. The computing device of claim 155, wherein the EMV card data comprises one or more of gift card data, prepaid card data, and stored value card data, and wherein the selected card is associated with one of the one of the gift card data, the prepaid card data, and the stored value card data.

160. A method of handling card data, the method comprising:

receiving, by a universal card from a computing device, EMV card data in an encrypted format;

decrypting, by a decrypting module in a secure element of the universal card, the EMV card data;

storing the decrypted EMV card data in the secure element of the universal card;

transmitting, by the universal card to the computing device, non-secure EMV card data, wherein the computing device comprises an e-wallet application configured to permit a user selection of an EMV card based on an identification of at least a portion of the non-secure EMV card data;

receiving, by the universal card from the computing device, an indication of the selected EMV card; and

configuring a dynamic EMV chip of the universal card to emulate a static EMV chip of the selected card using at least a portion of the decrypted EMV card data stored in the secure element.

161. The method of claim 160, wherein receiving, by the universal card from the computing device, the EMV card data in the encrypted format comprises receiving the EMV card data in the encrypted format via a short range transceiver of the universal card.

162. The method of claim 160, wherein the computing device is configured to receive the EMV card data in the encrypted format from a trusted source.

163. The method of claim 160, wherein the computing device is configured to receive the EMV card data in the encrypted format via a network.

164. The method of claim 160, wherein the EMV card data comprises one or more of gift card data, prepaid card data, and stored value card data, and wherein the selected card is associated with one of the one of the gift card data, the prepaid card data, and the stored value card data.



165. A computer readable medium having instructions embodied thereon for handling card data, the instructions comprising:

instructions to receive, by a universal card from a computing device, EMV card data in an encrypted format;

instructions to decrypt, by a decrypting module in a secure element of the universal card, the EMV card data;

instructions to store the decrypted EMV card data in the secure element of the universal card;

instructions to transmit, by the universal card to the computing device, non-secure EMV card data, wherein the computing device comprises an e-wallet application configured to permit a user selection of an EMV card based on an identification of at least a portion of the non-secure EMV card data;

instructions to receive, by the universal card from the computing device, an indication of the selected EMV card; and

instructions to configure a dynamic EMV chip of the universal card to emulate a static EMV chip of the selected card using at least a portion of the decrypted EMV card data stored in the secure element.

166. The computer readable medium of claim 23, wherein the instructions to receive, by the universal card from the computing device, the EMV card data in the encrypted format comprise instructions to receive the EMV card data in the encrypted format via a short range transceiver of the universal card.

167. The computer readable medium of claim 165, wherein the computing device is configured to receive the EMV card data in the encrypted format from a trusted source.

168. The computer readable medium of claim 165, wherein the computing device is configured to receive the EMV card data in the encrypted format via a network.

169. The computer readable medium of claim 165, wherein the EMV card data comprises one or more of gift card data, prepaid card data, and stored value card data, and wherein the selected card is associated with one of the one of the gift card data, the prepaid card data, and the stored value card data.

170. A universal card comprising:

a dynamic EMV chip;

a secure element comprising a decrypting module; and

a computer readable medium having instructions embodied thereon, the instructions comprising:

instructions to receive, from a computing device, EMV card data in an encrypted format;

instructions to decrypt, by the decrypting module, the EMV card data;

instructions to store the decrypted EMV card data in the secure element;

instructions to transmit, to the computing device, non-secure EMV card data,

wherein the computing device comprises an e-wallet application configured to permit a user selection of an EMV card based on an identification of at least a portion of the non-secure EMV card data;

instructions to receive, from the computing device, an indication of the selected EMV card; and

instructions to configure the dynamic EMV chip to emulate a static EMV chip of the selected card using at least a portion of the decrypted EMV card data stored in the secure element.

171. The universal card of claim 170, the universal card further comprising:

a short range transceiver, wherein the instructions to receive, from the computing device, the EMV card data in the encrypted format comprise instructions to receive the EMV card data in the encrypted format via the short range transceiver.

172. The universal card of claim 170, wherein the computing device is configured to receive the EMV card data in the encrypted format from a trusted source.

173. The universal card of claim 170, wherein the computing device is configured to receive the EMV card data in the encrypted format via a network.

174. The universal card of claim 170, wherein the EMV card data comprises one or more of gift card data, prepaid card data, and stored value card data, and wherein the selected card is associated with one of the one of the gift card data, the prepaid card data, and the stored value card data.

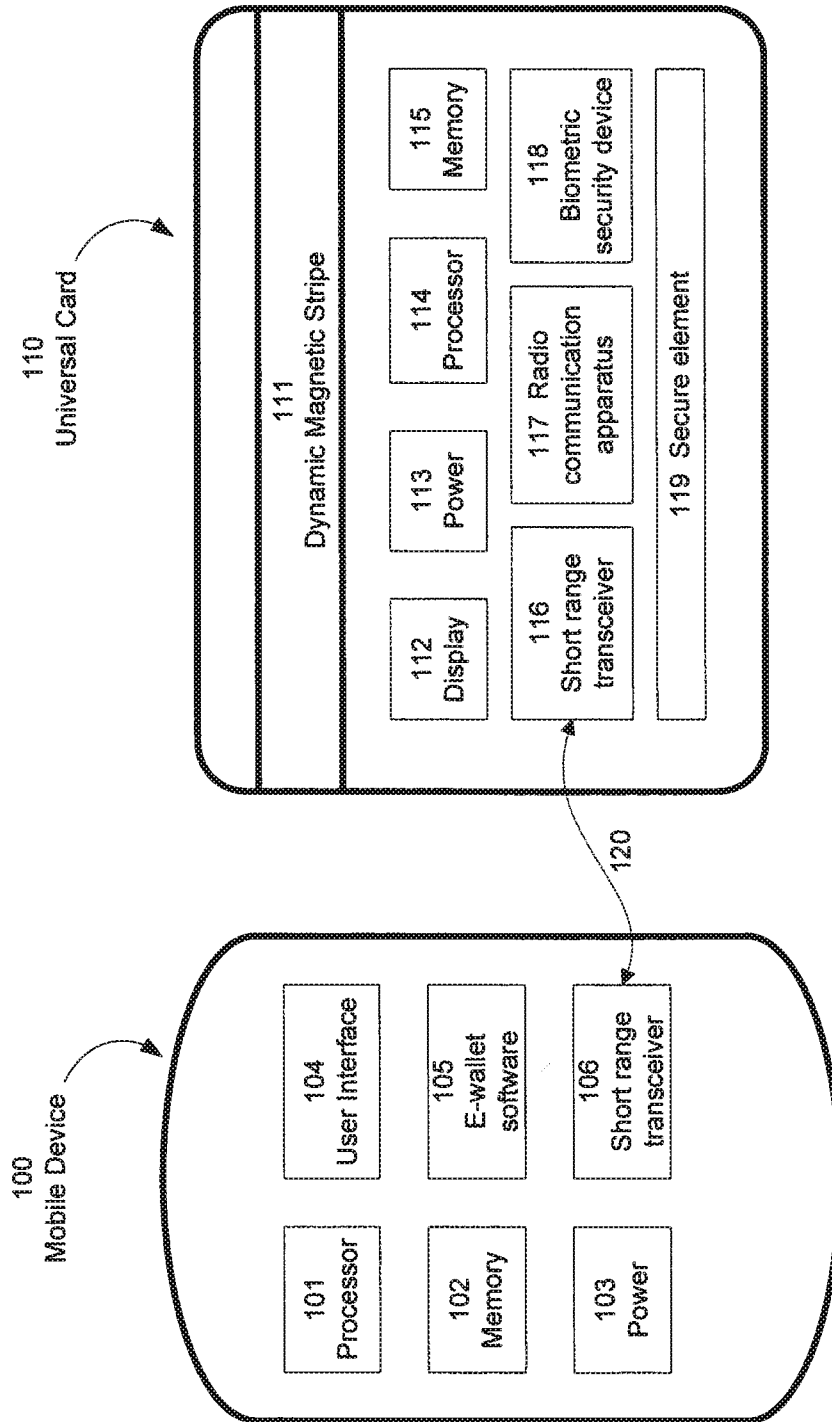


FIGURE 1

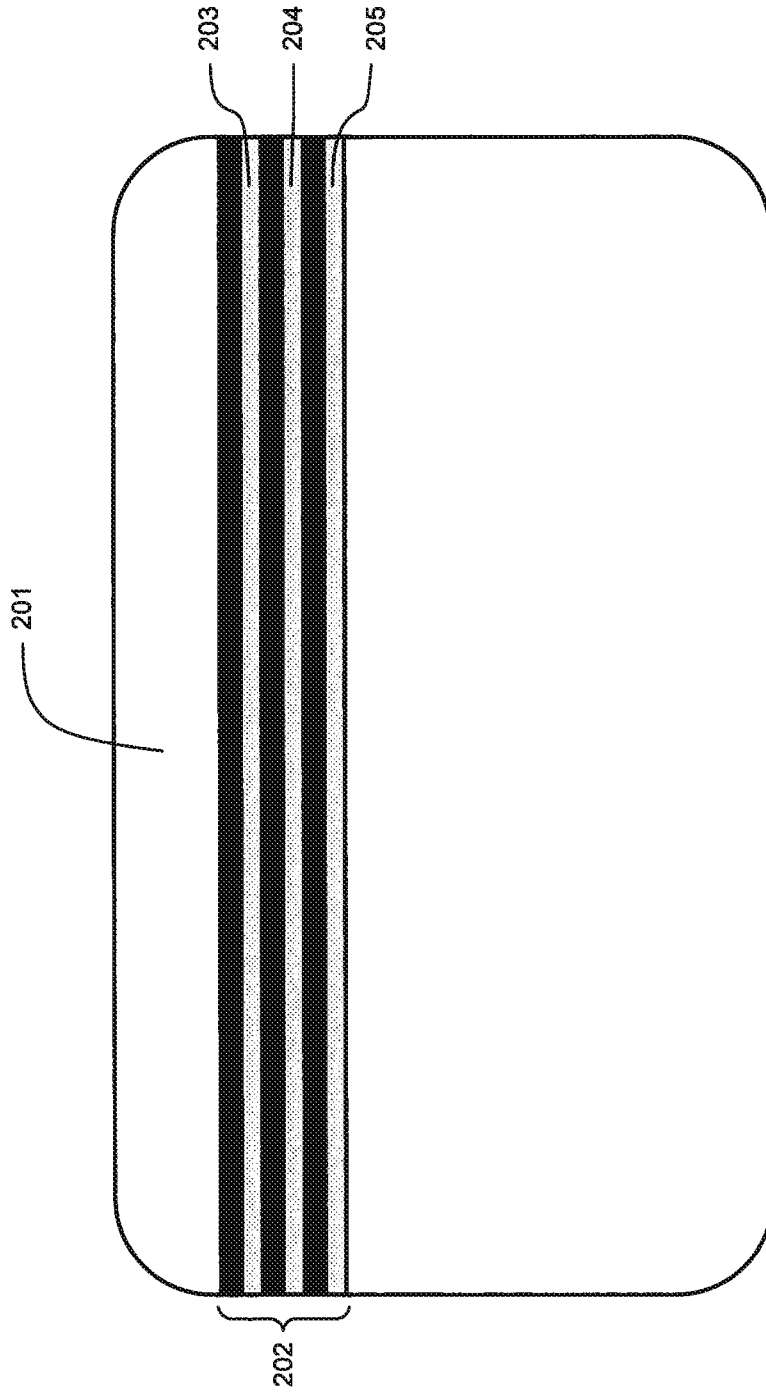
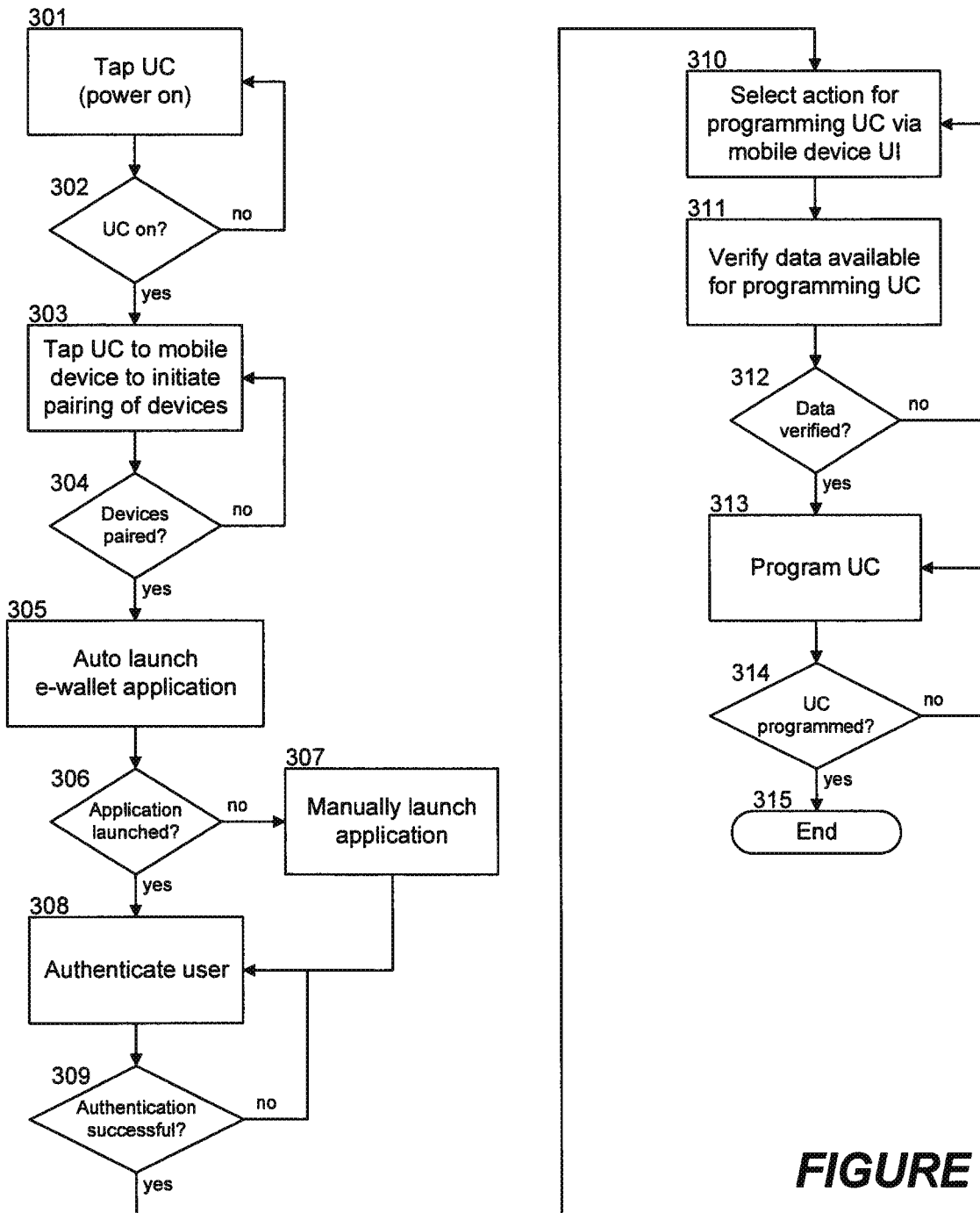
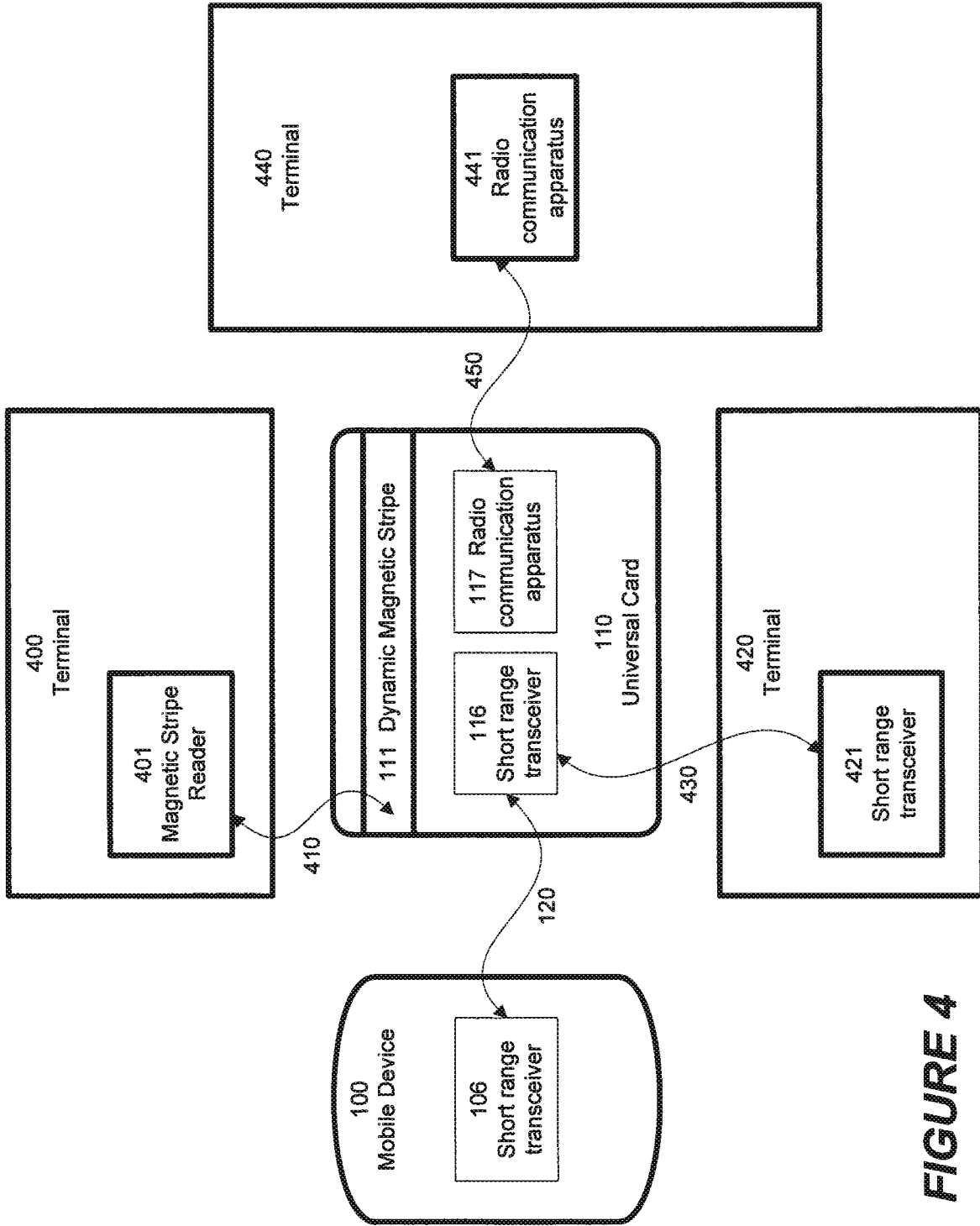


FIGURE 2



**FIGURE 3**



**FIGURE 4**

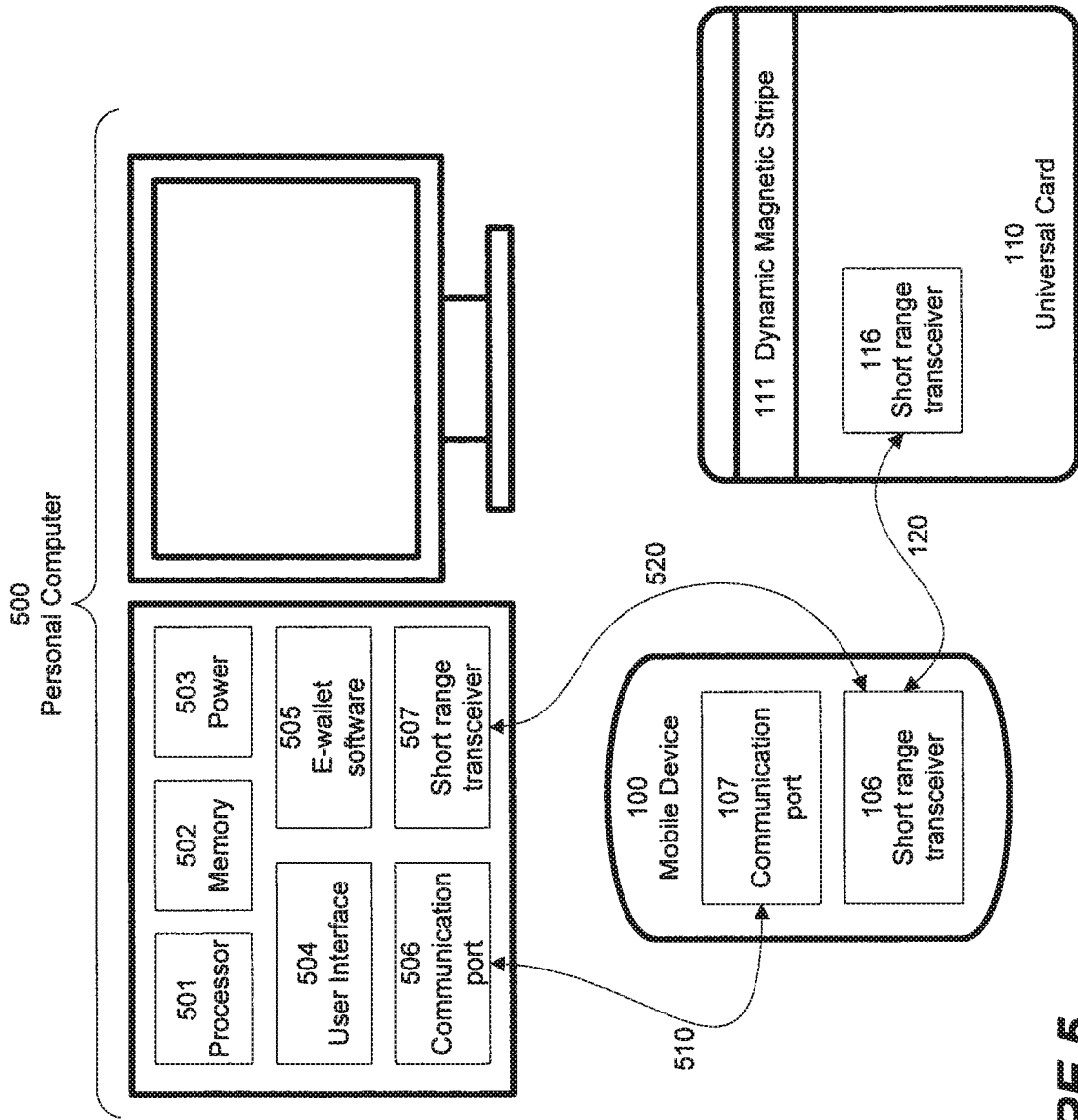
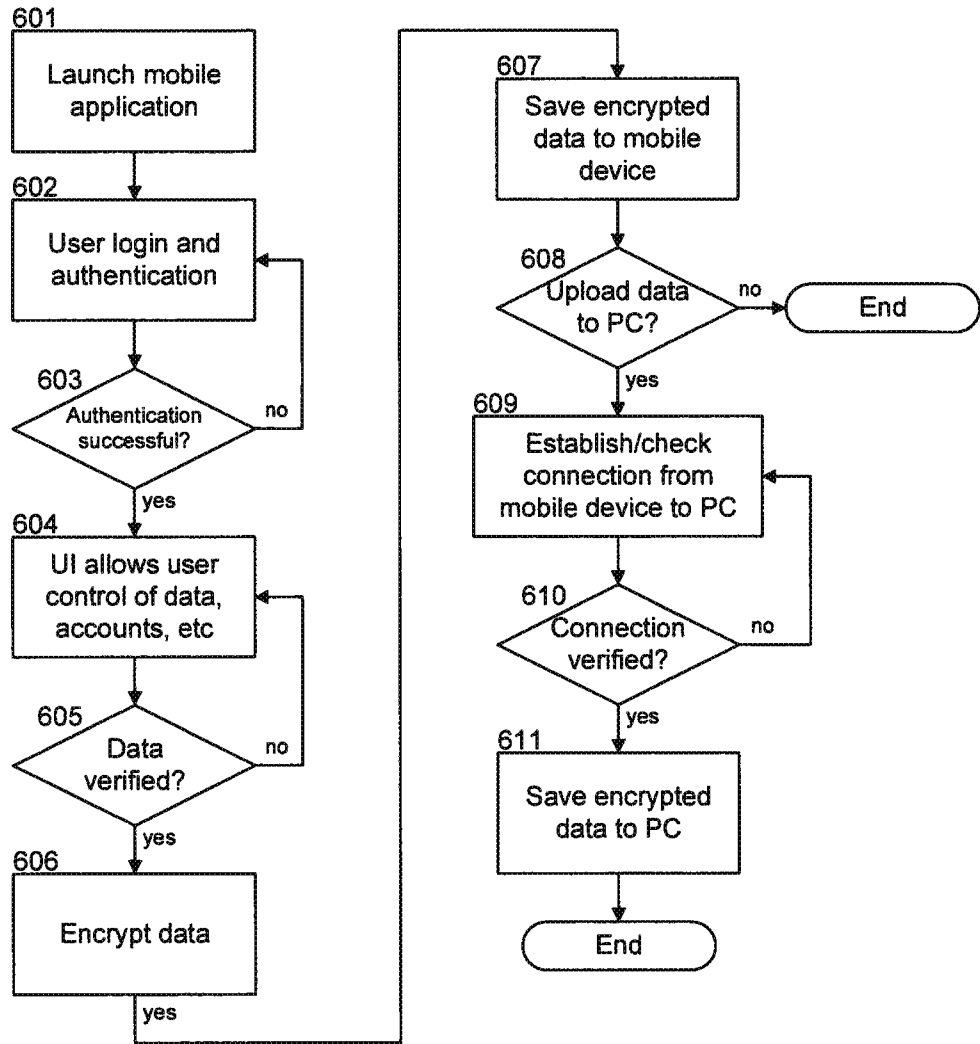
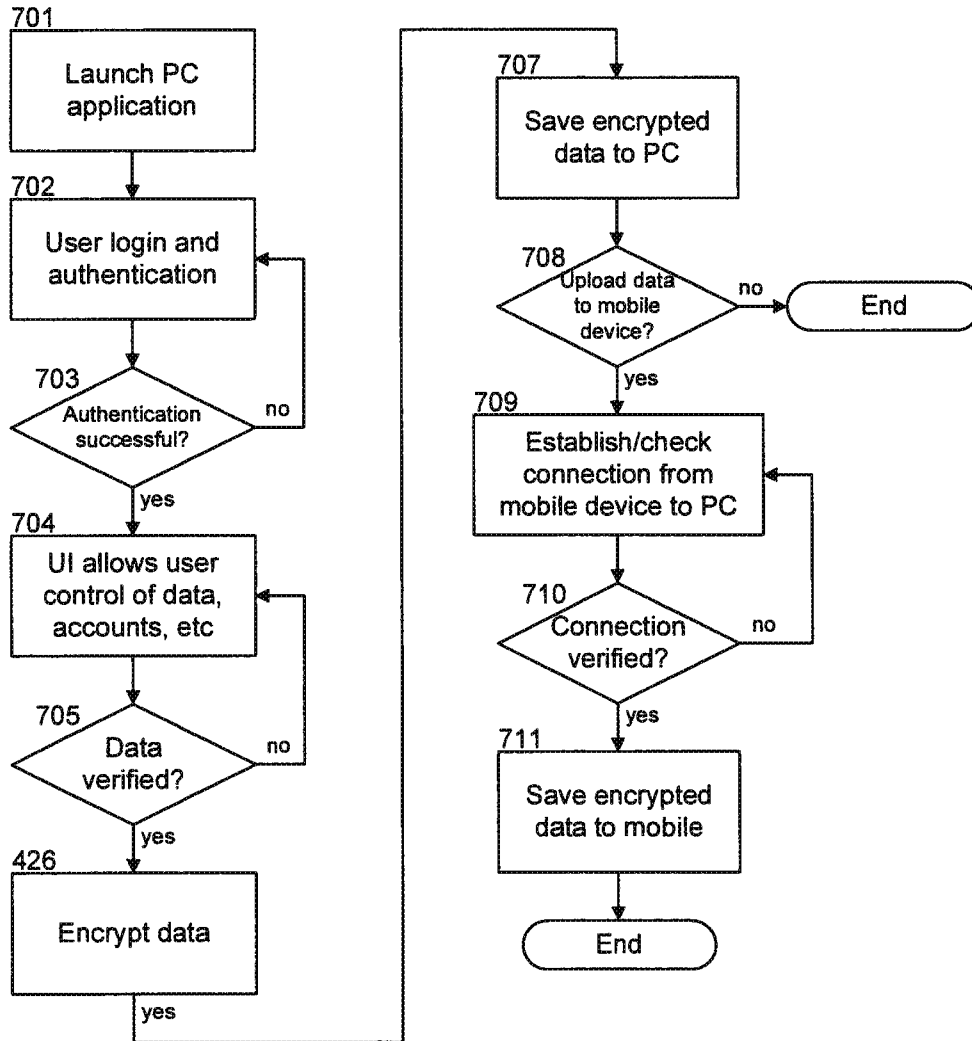


FIGURE 5

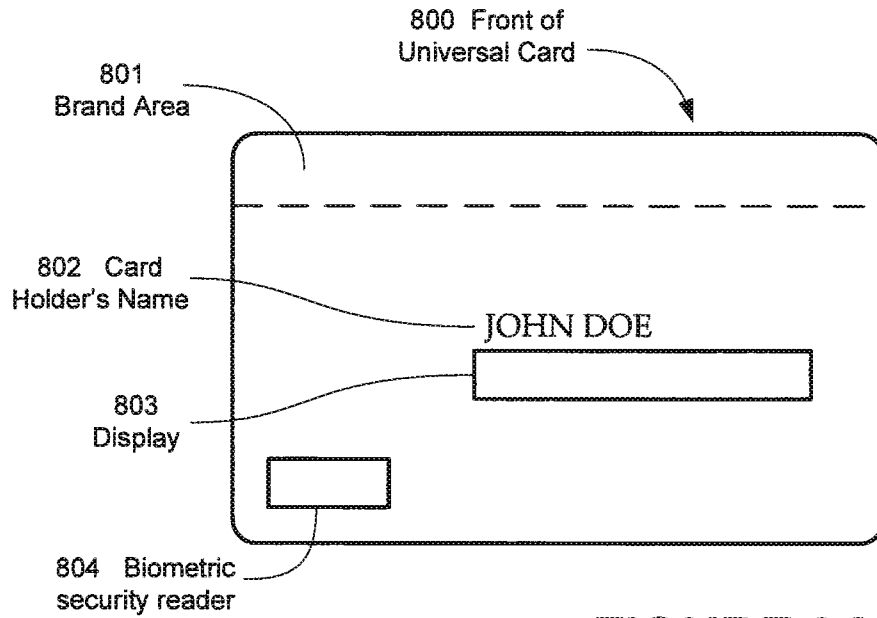


**FIGURE 6**

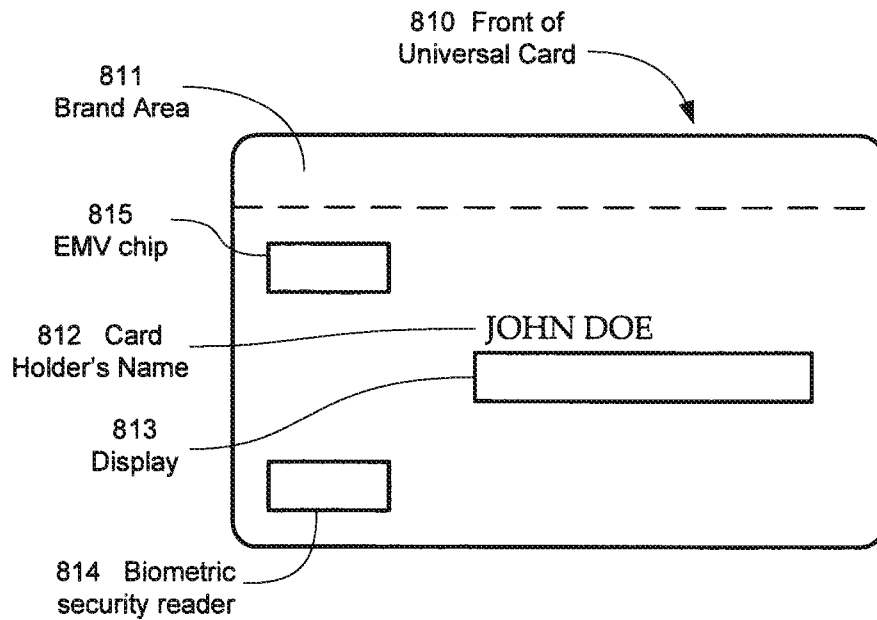




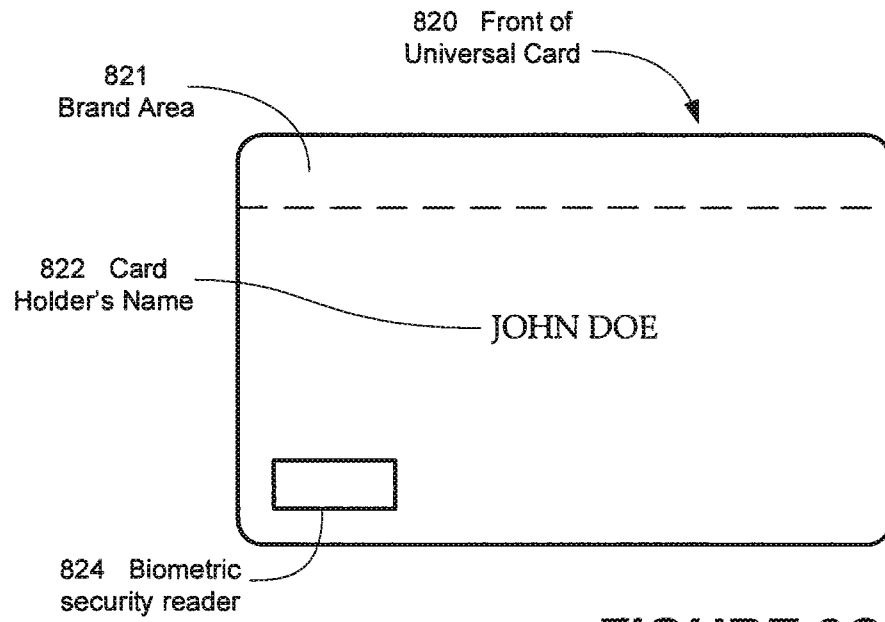
**FIGURE 7**



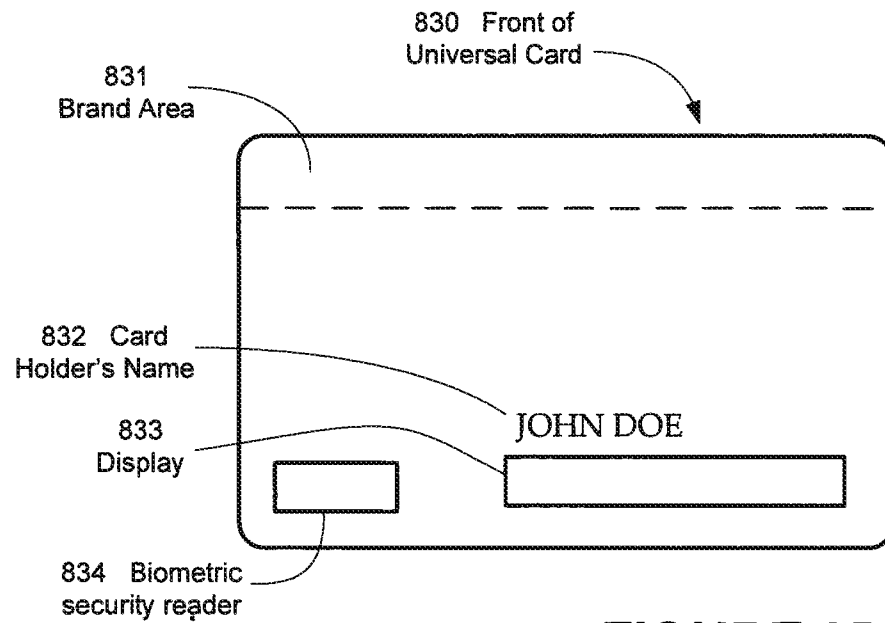
**FIGURE 8A**



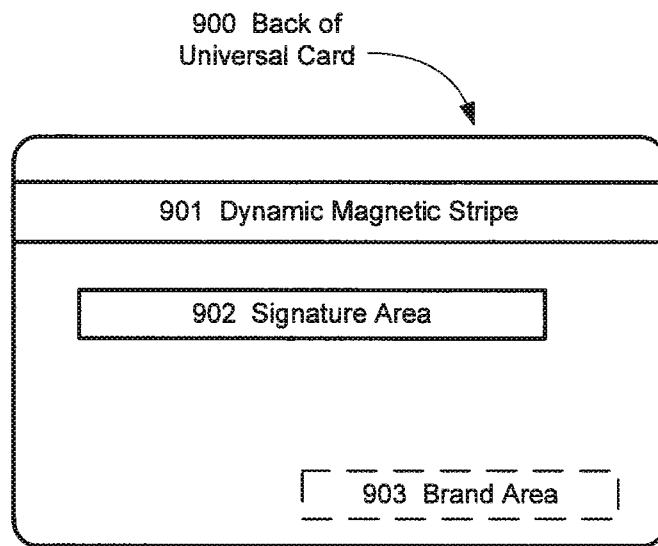
**FIGURE 8B**



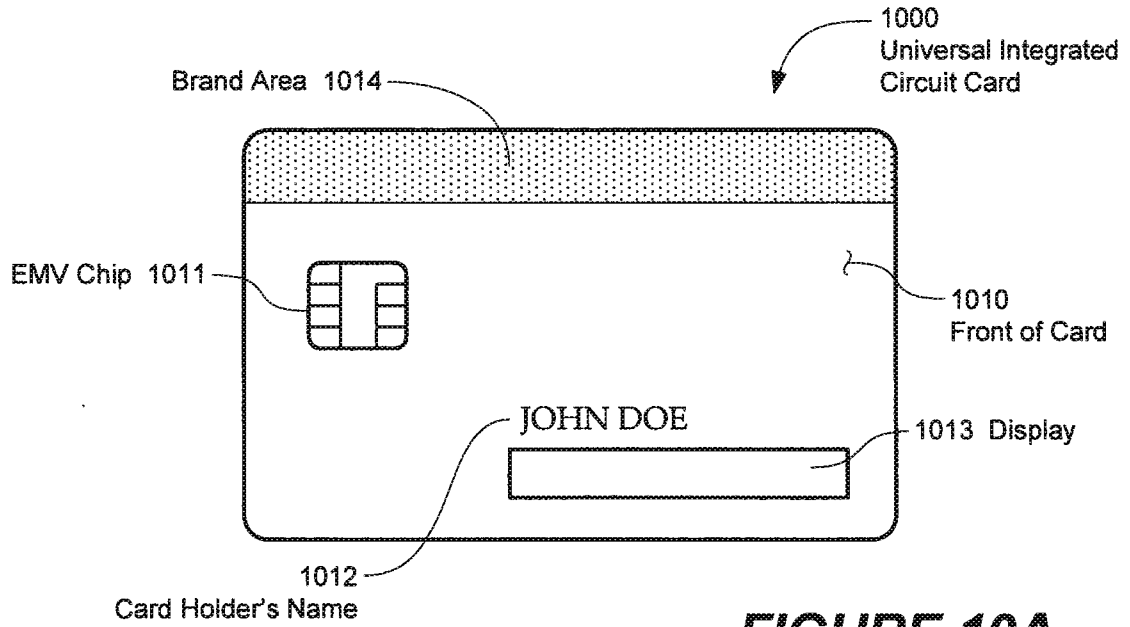
**FIGURE 8C**



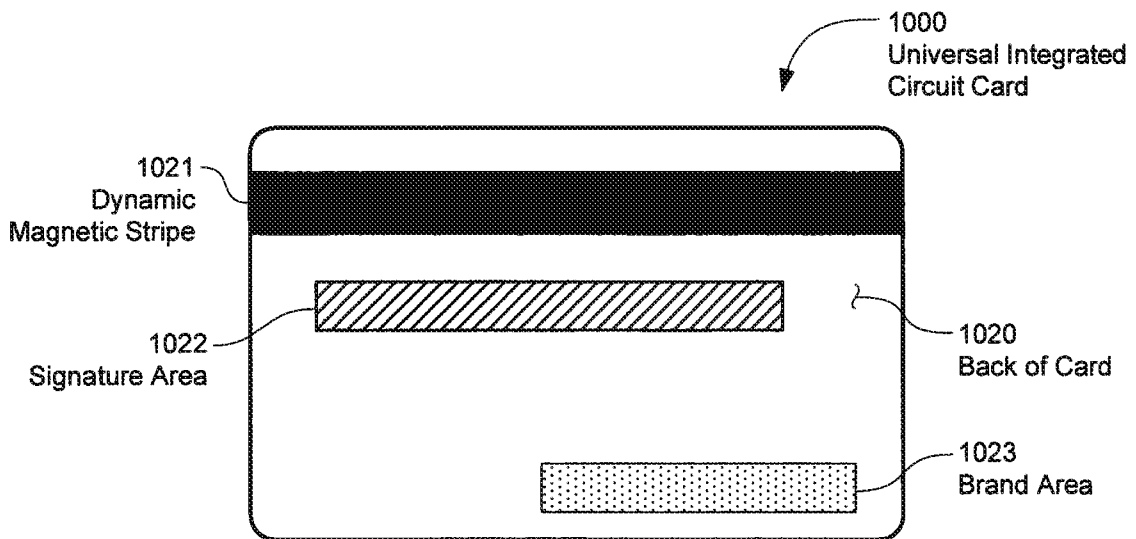
**FIGURE 8D**



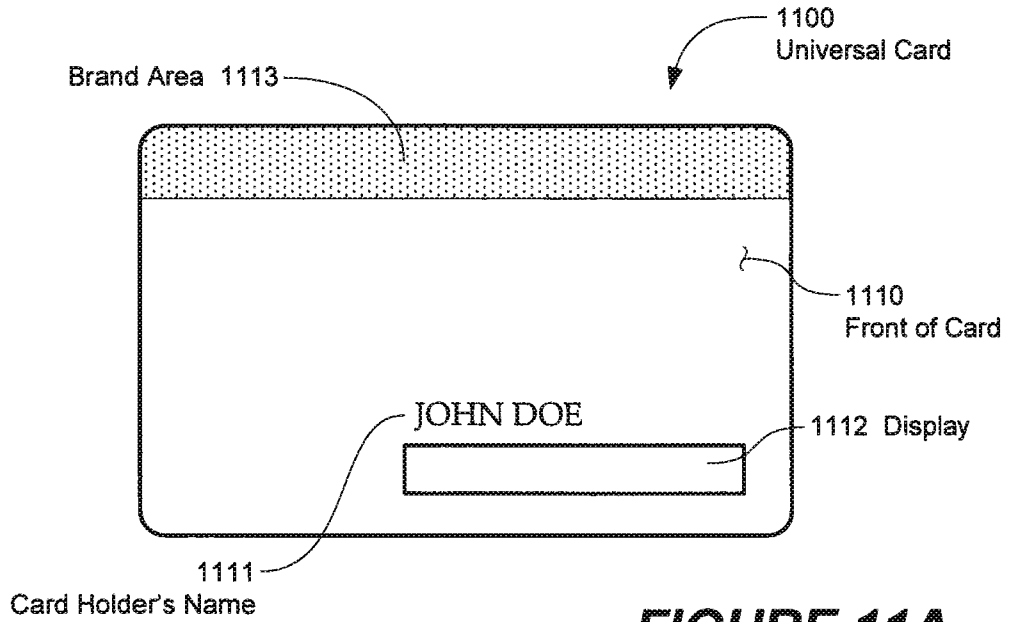
**FIGURE 9**



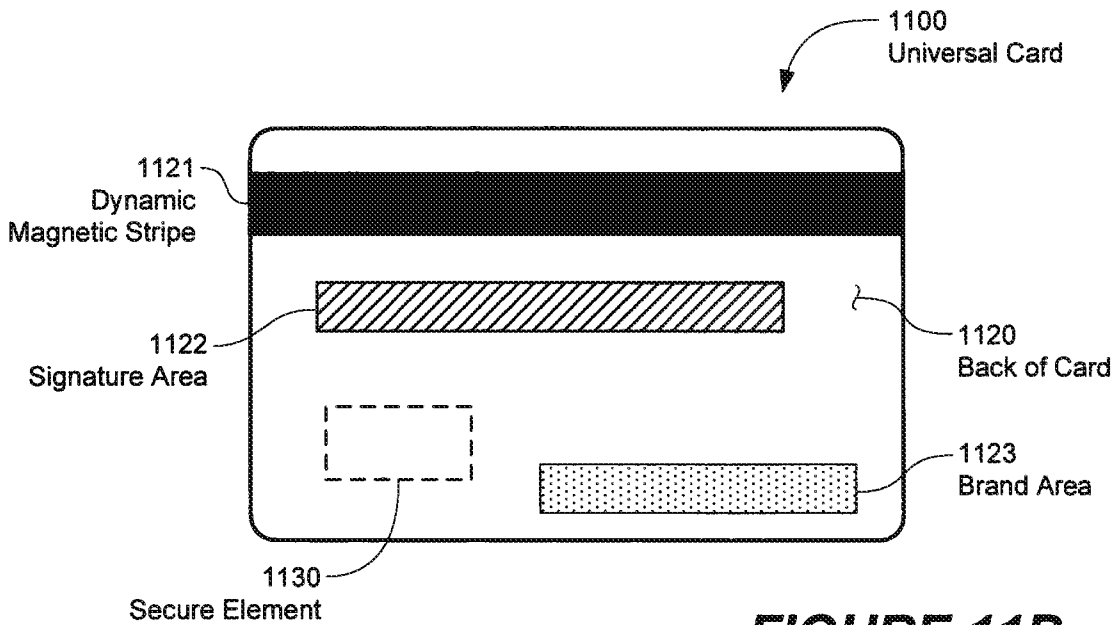
**FIGURE 10A**



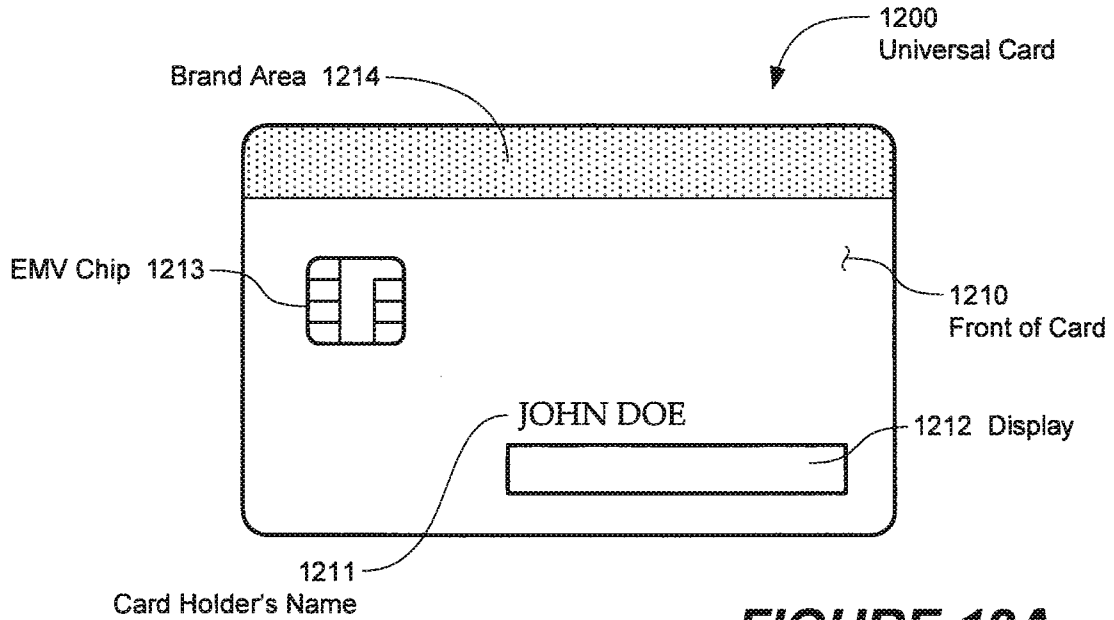
**FIGURE 10B**



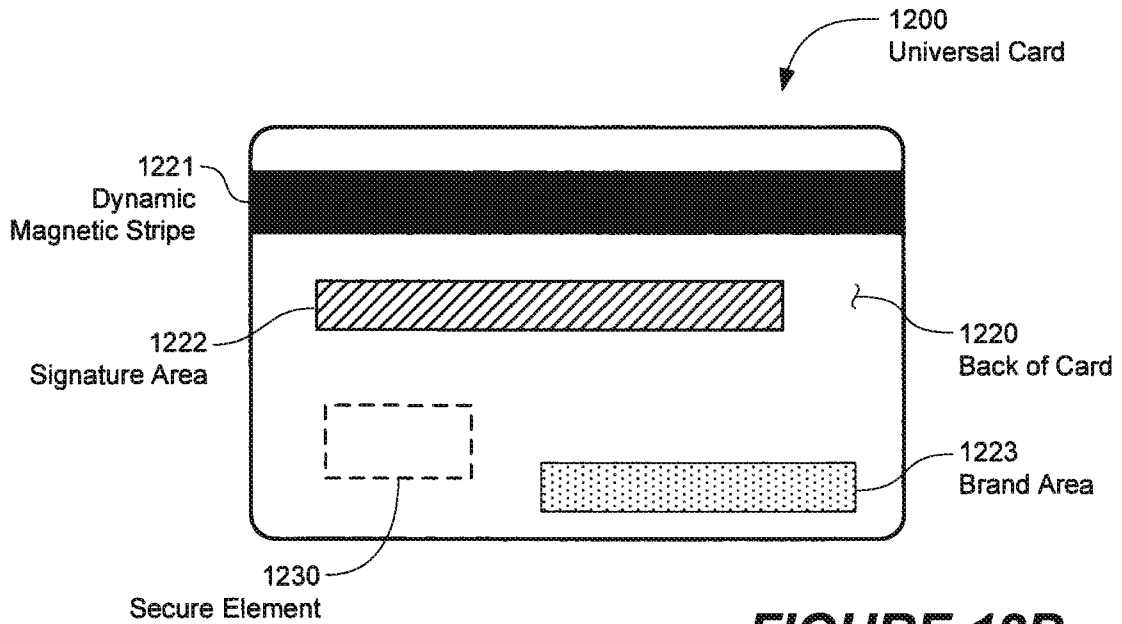
**FIGURE 11A**



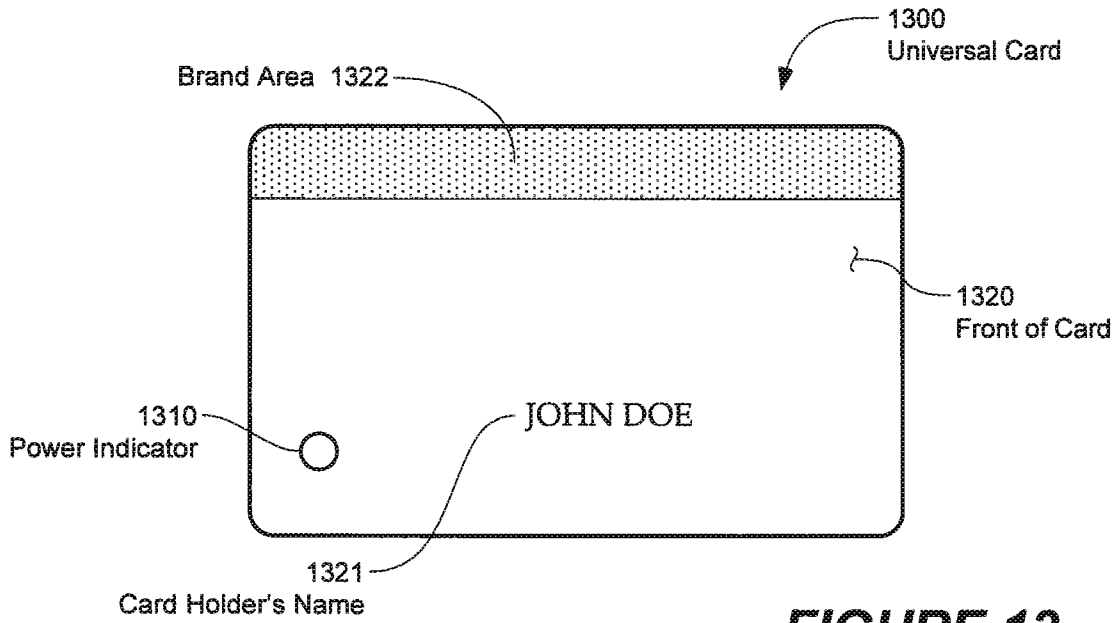
**FIGURE 11B**



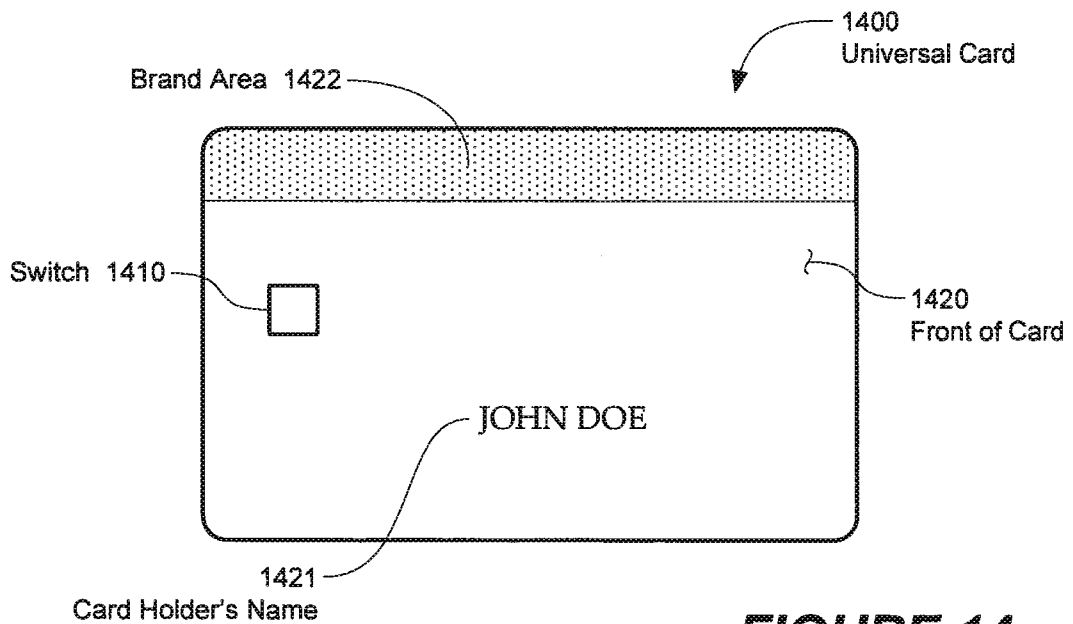
**FIGURE 12A**



**FIGURE 12B**

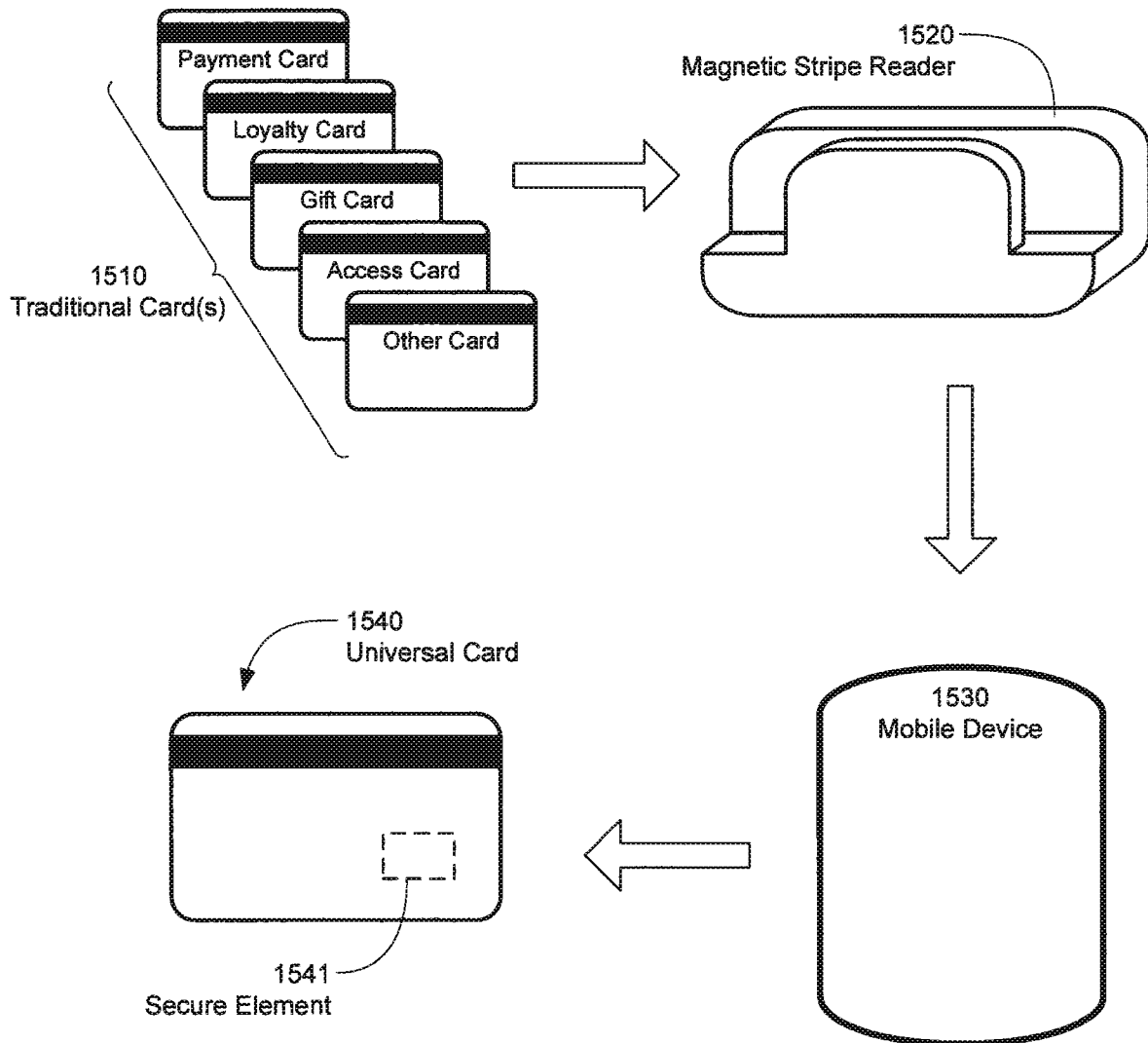


**FIGURE 13**

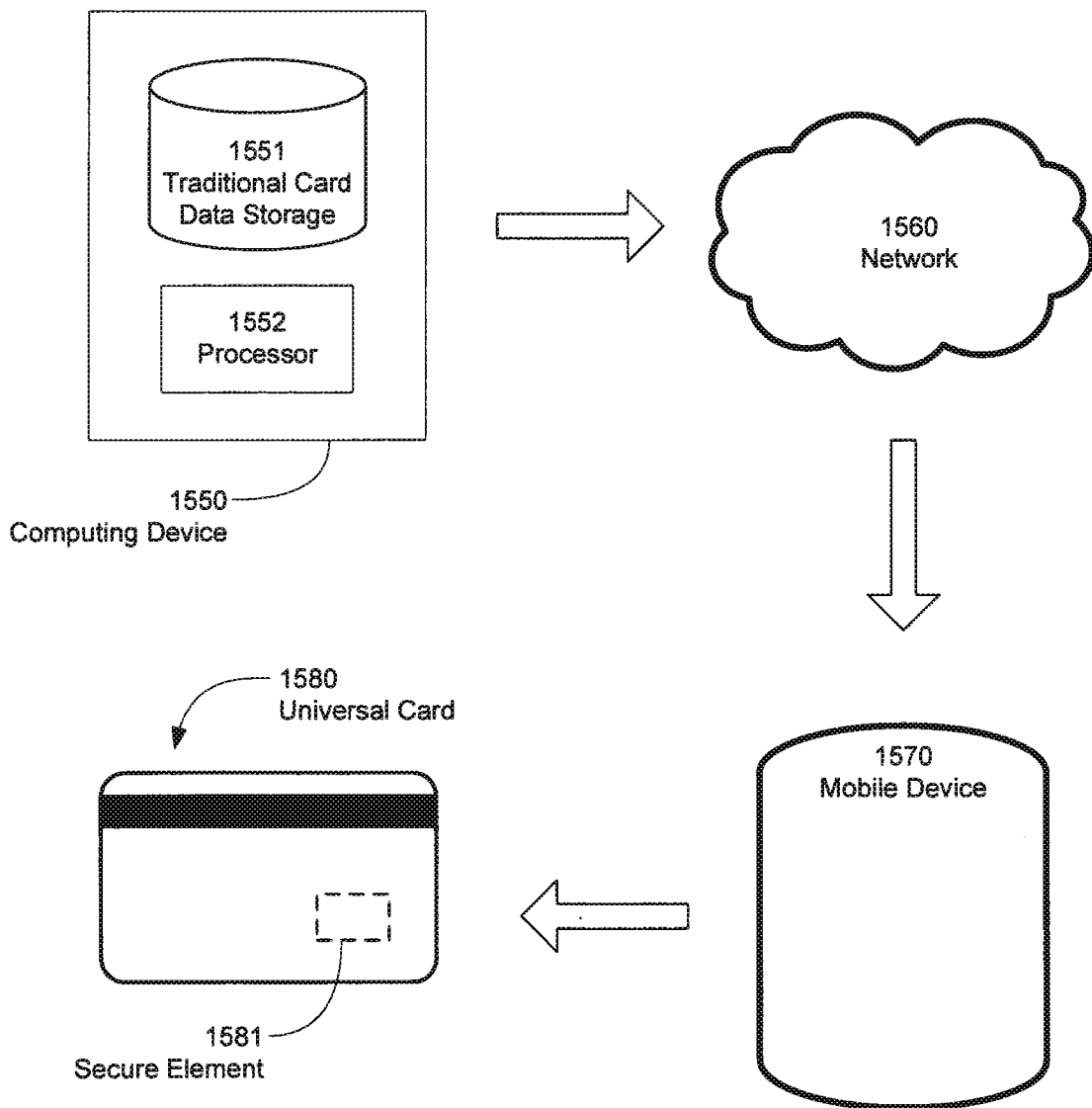


**FIGURE 14**



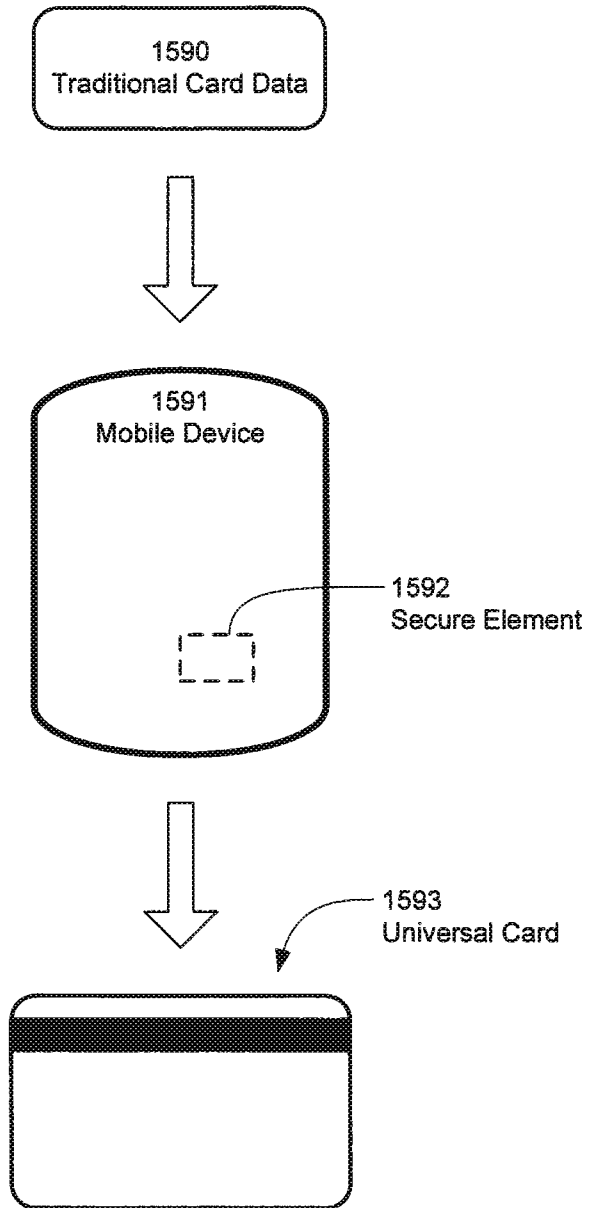


**FIGURE 15A**

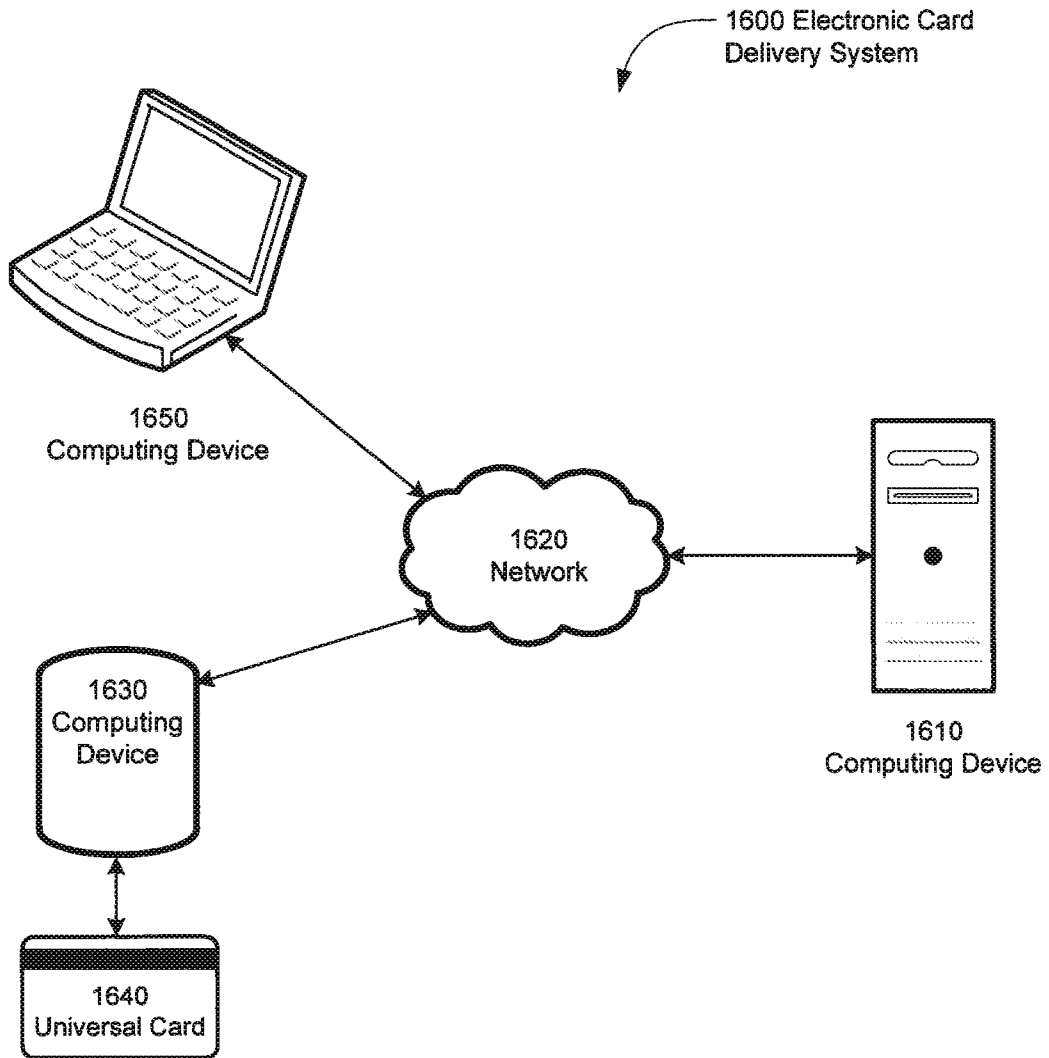


**FIGURE 15B**

17/34

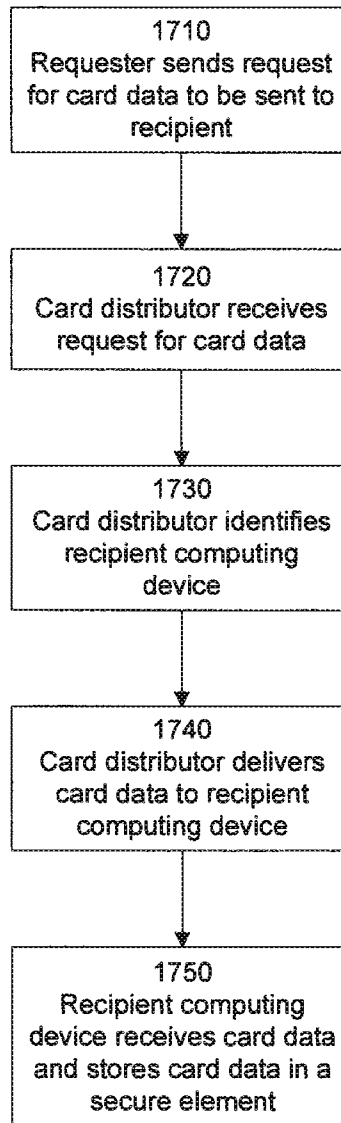


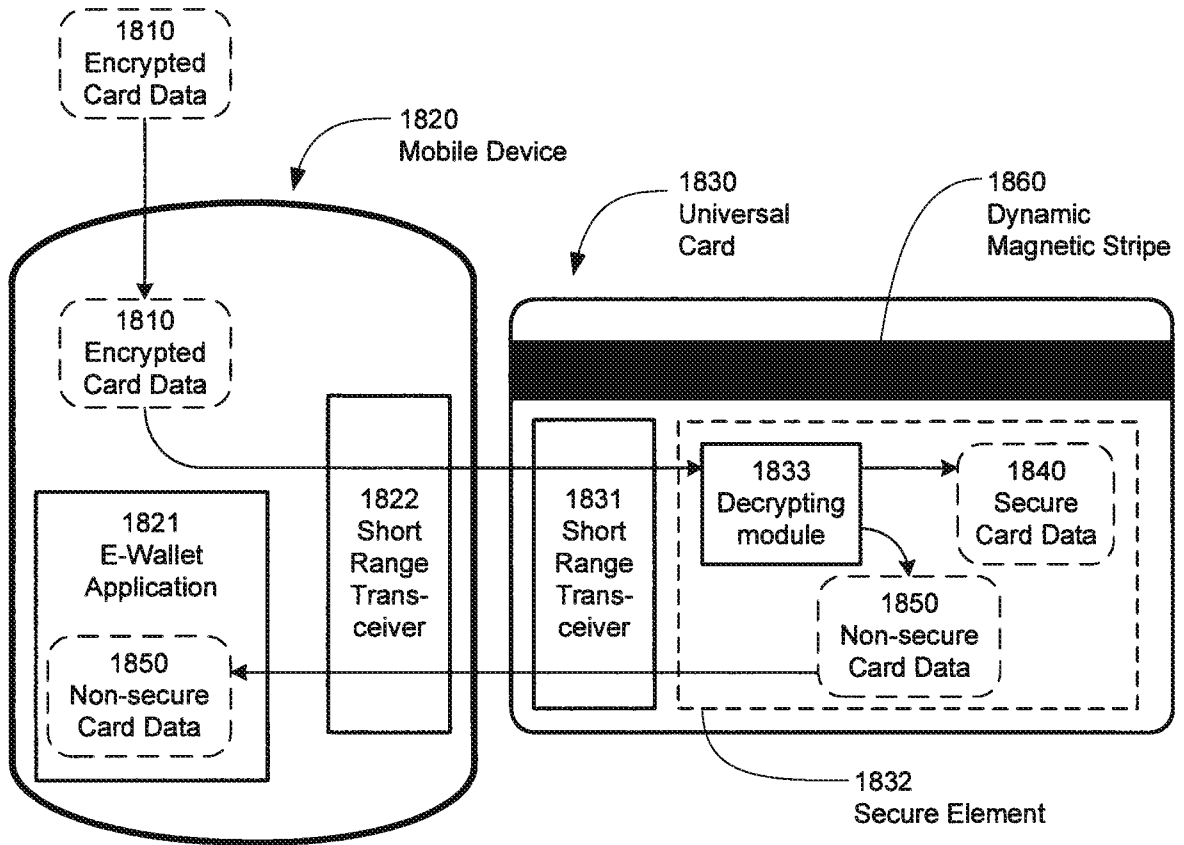
**FIGURE 15C**



**FIGURE 16**

19/34

**FIGURE 17**



**FIGURE 18**

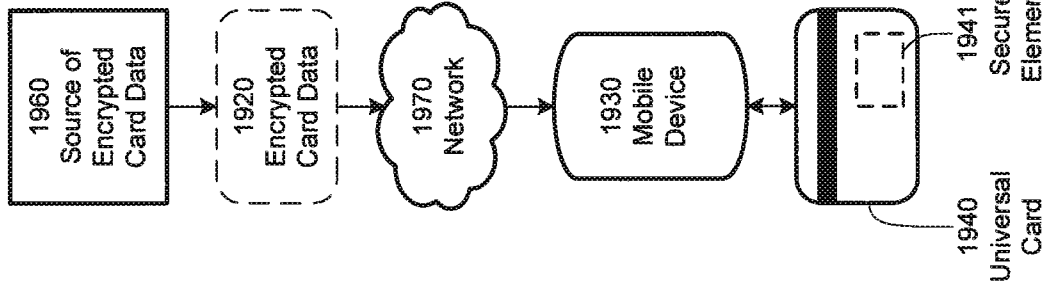


FIGURE 19C

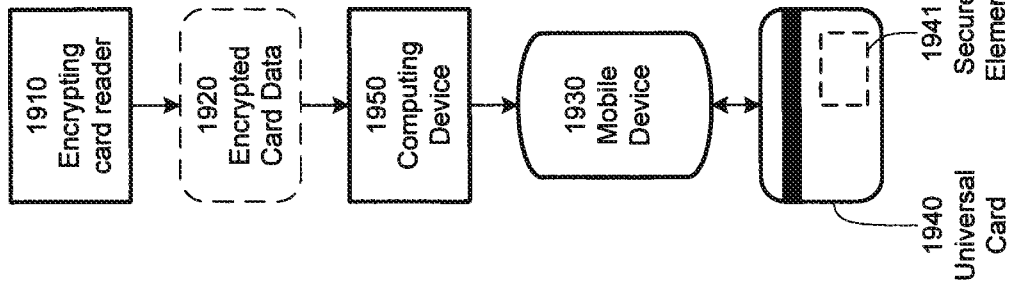


FIGURE 19B

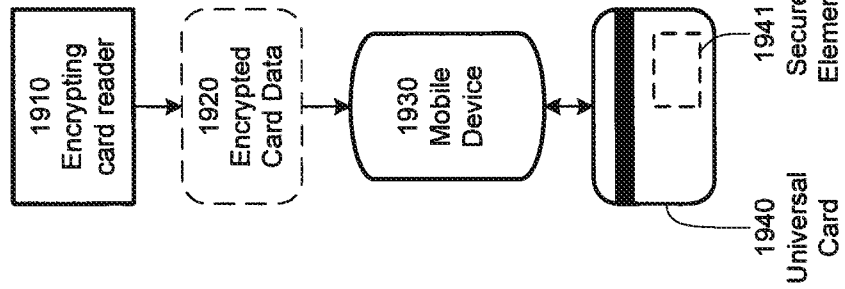
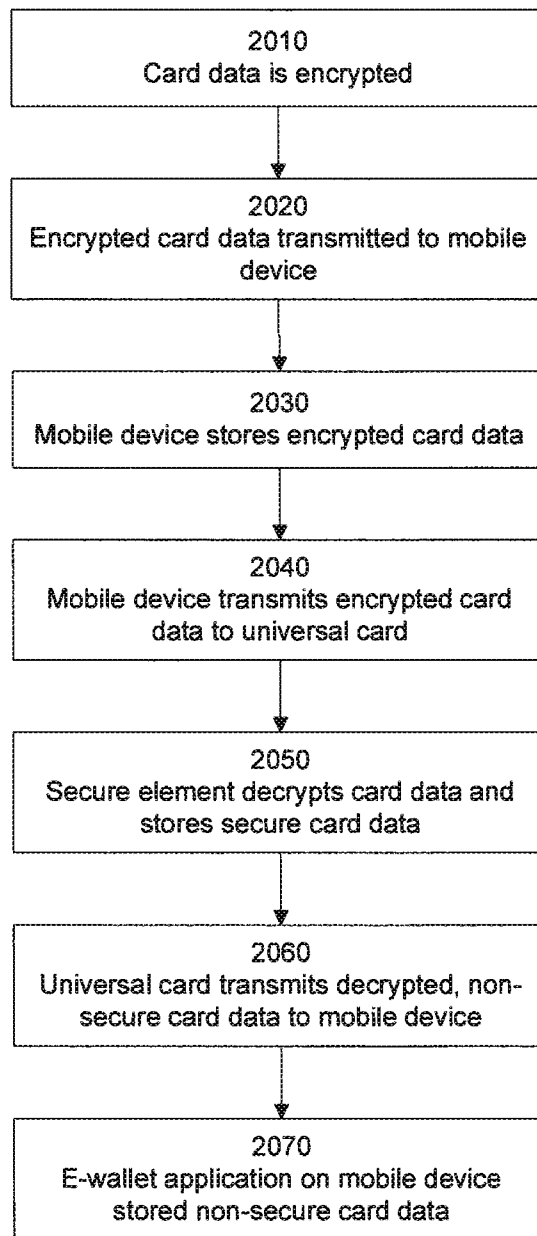
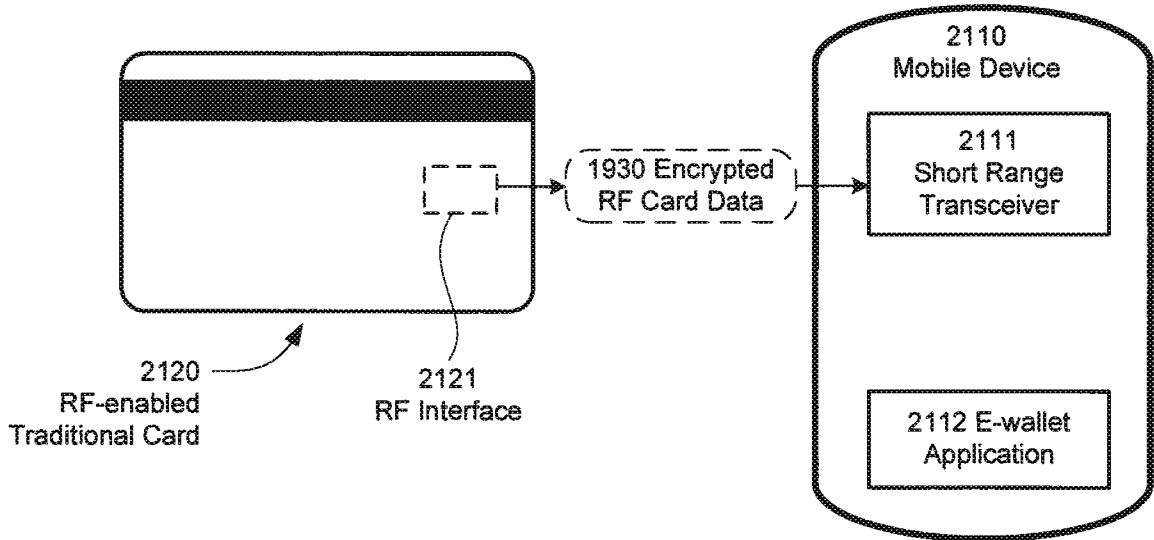


FIGURE 19A

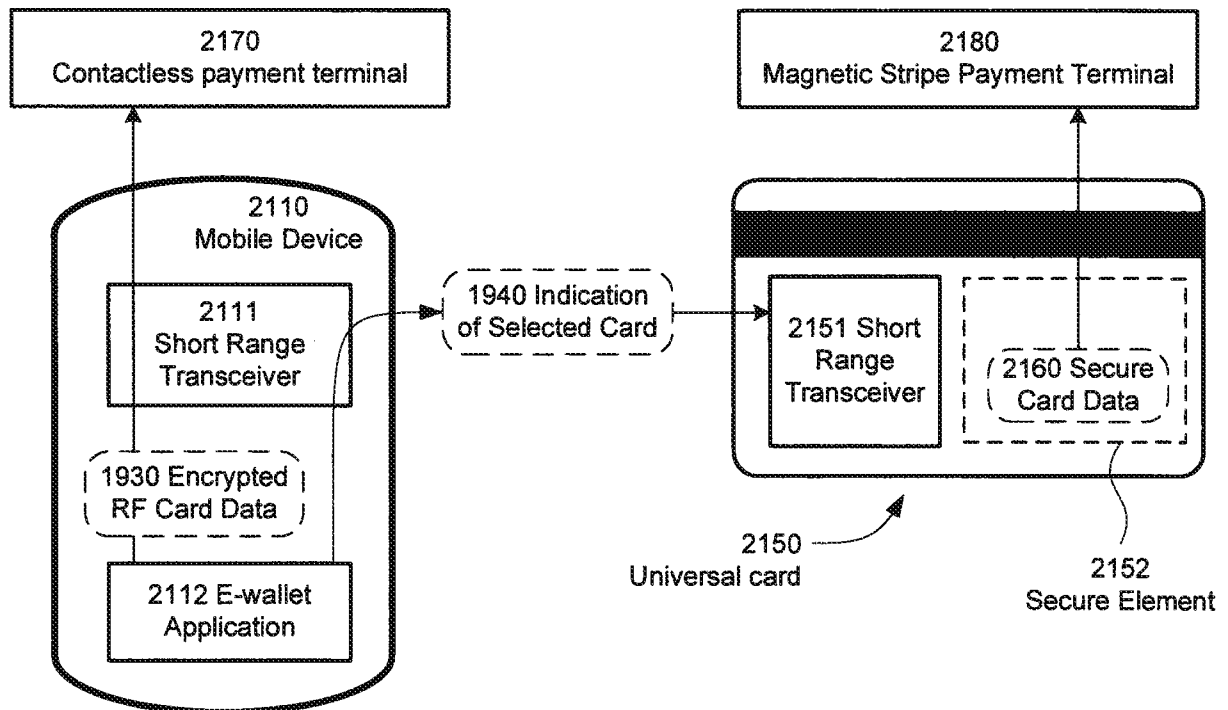
22/34

**FIGURE 20**





**FIGURE 21A**



**FIGURE 21B**

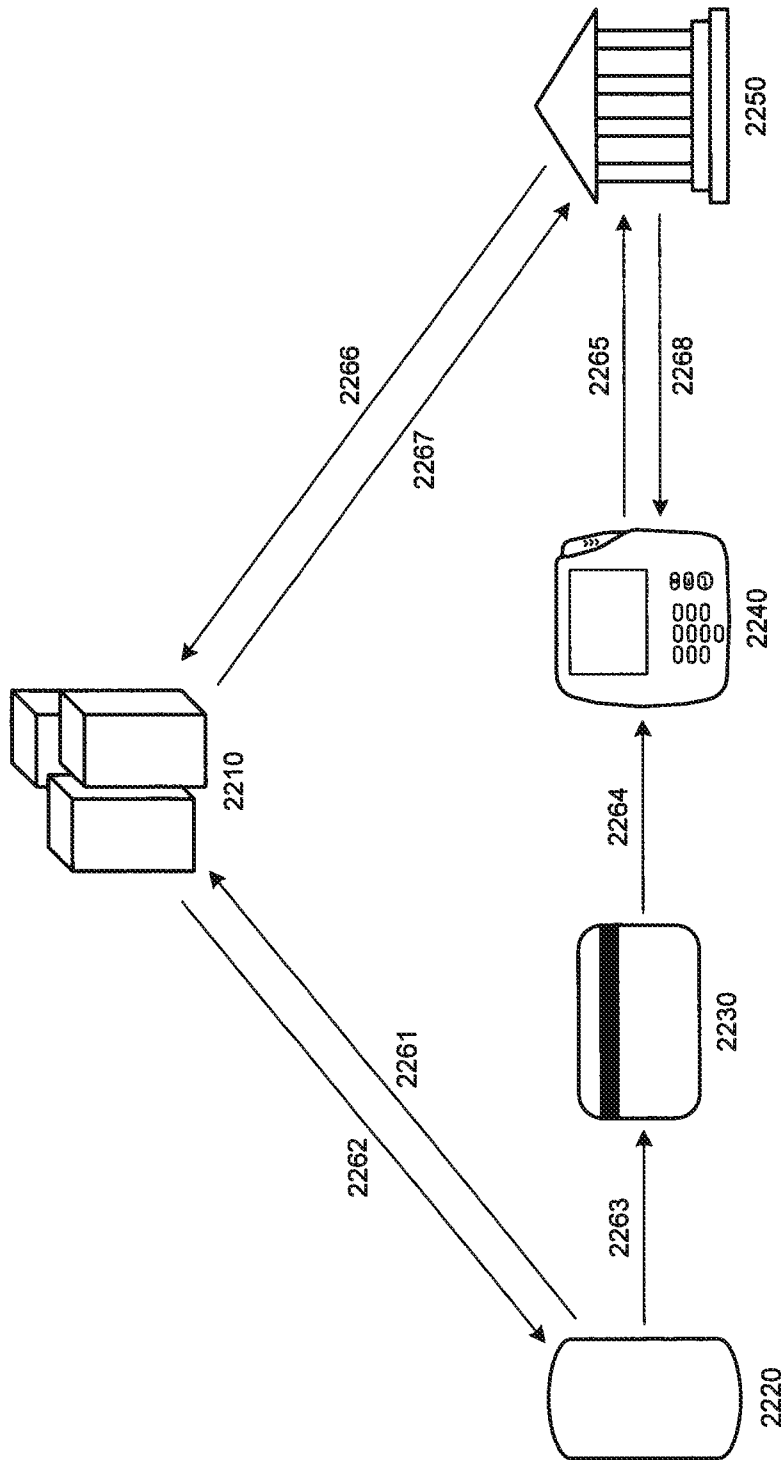


FIGURE 22

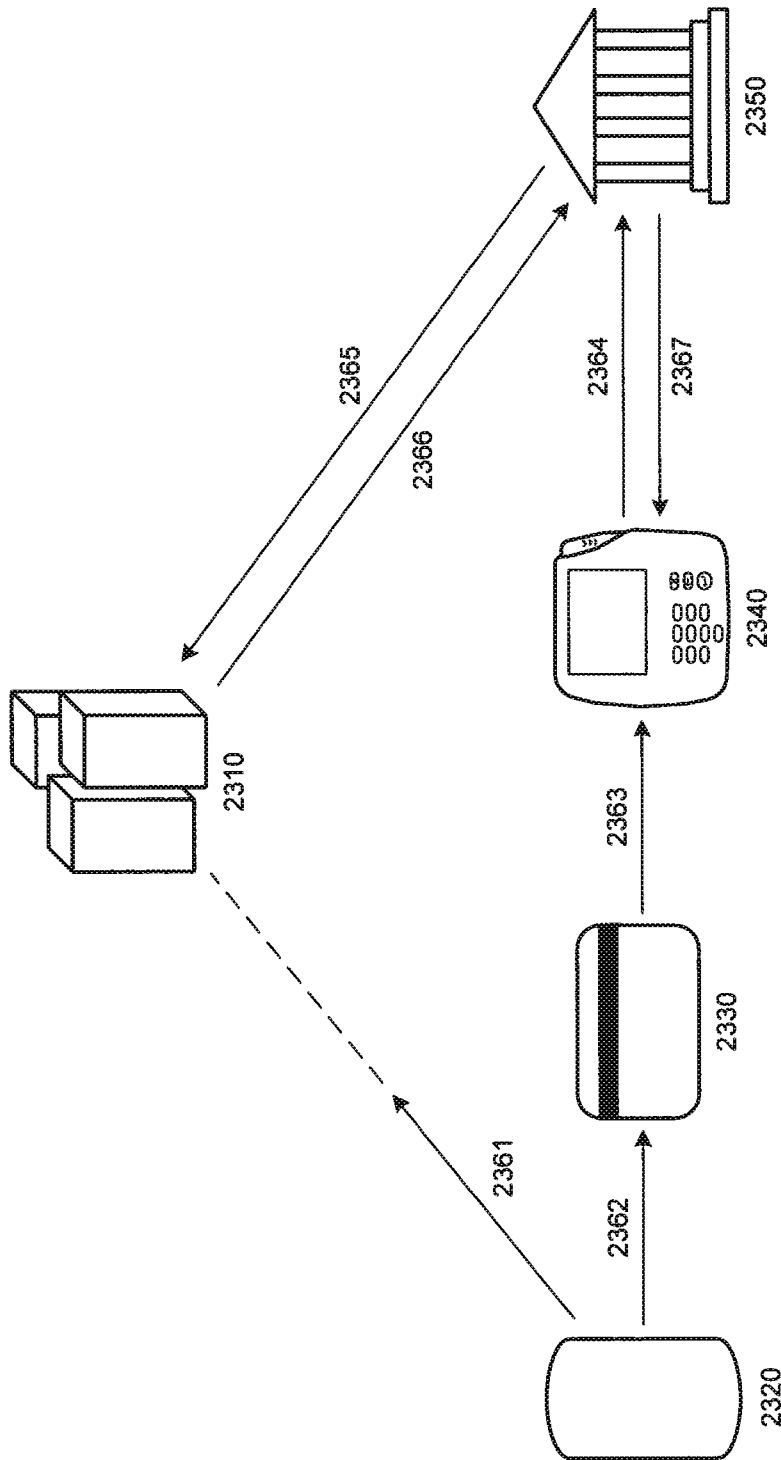
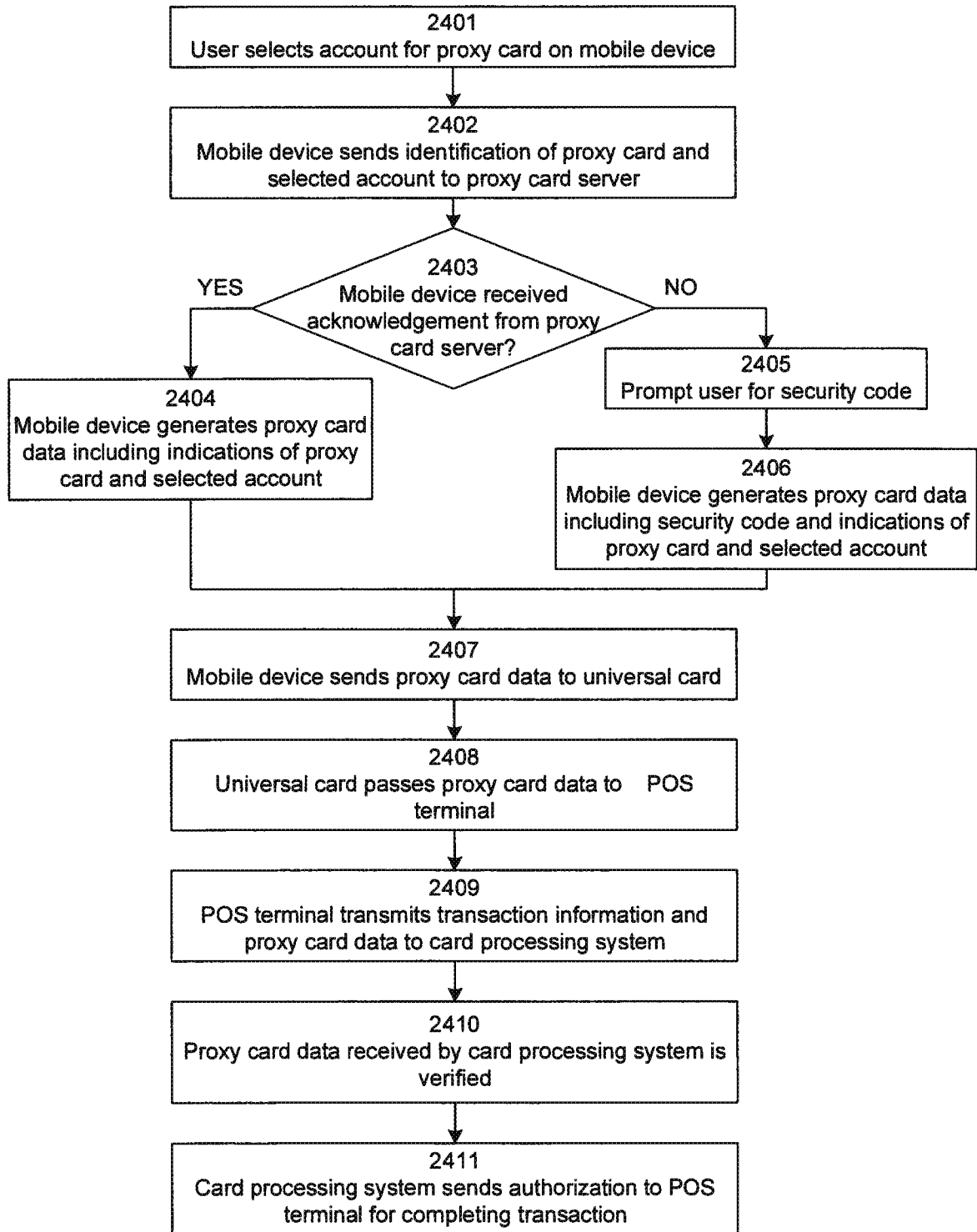
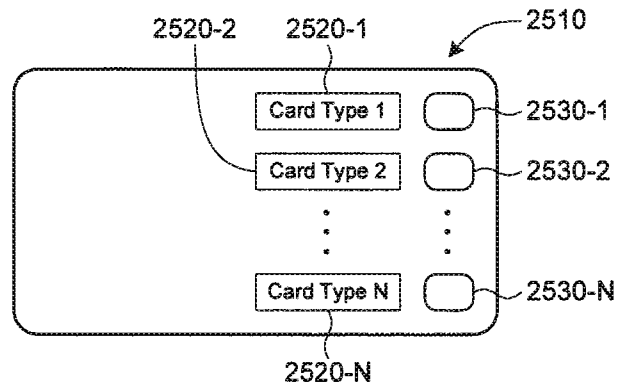


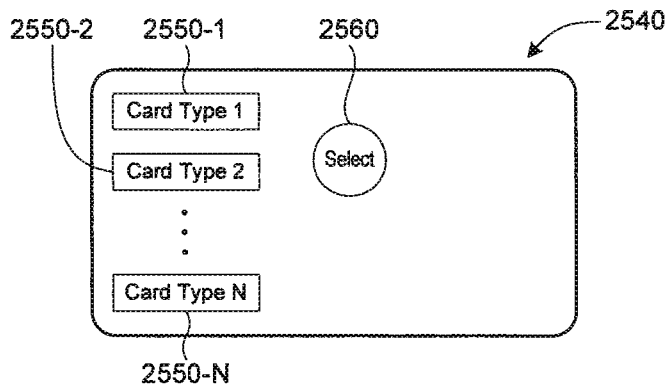
FIGURE 23



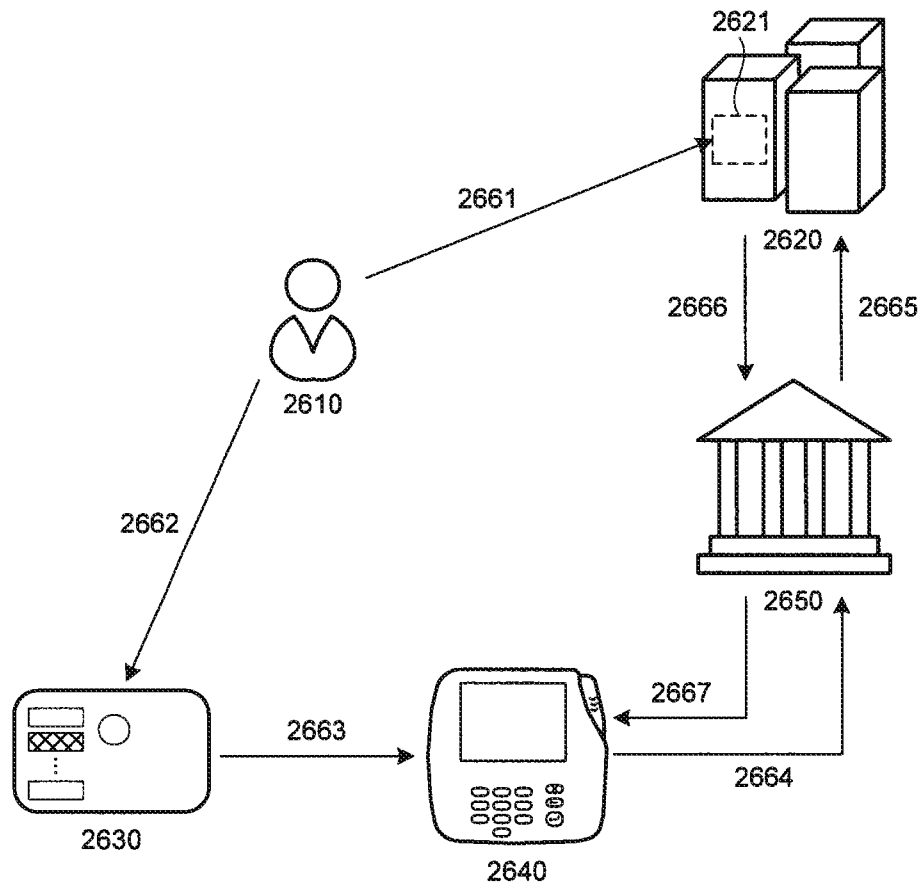
**FIGURE 24**



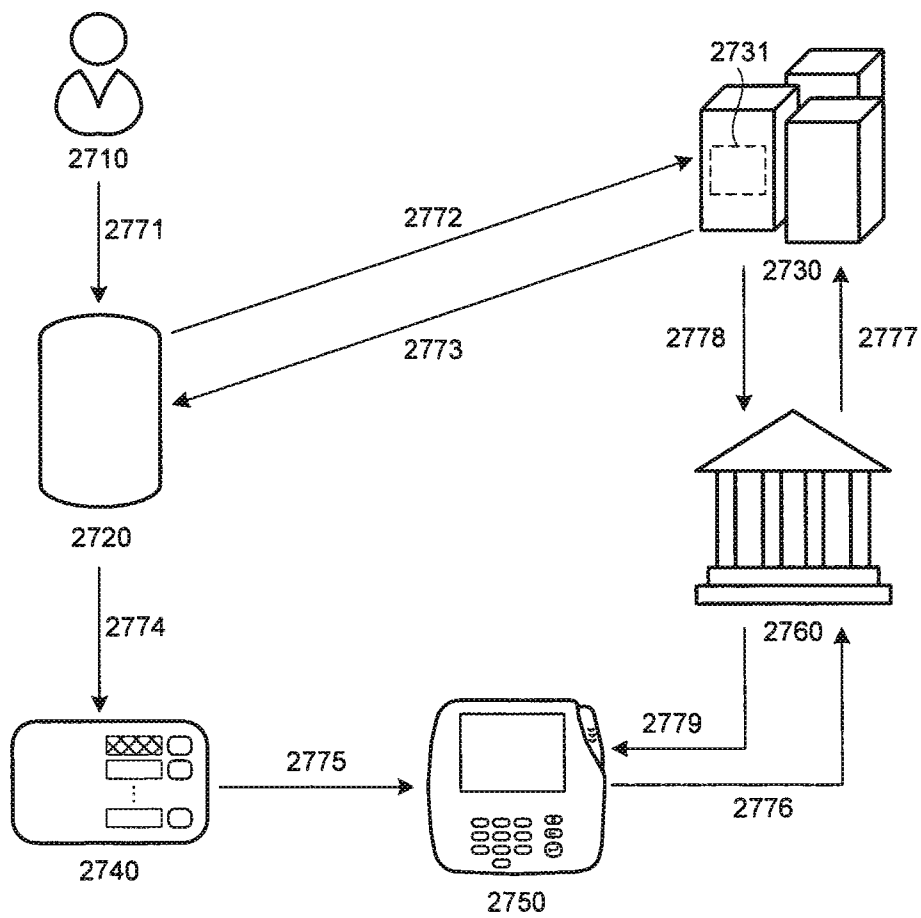
**FIGURE 25A**



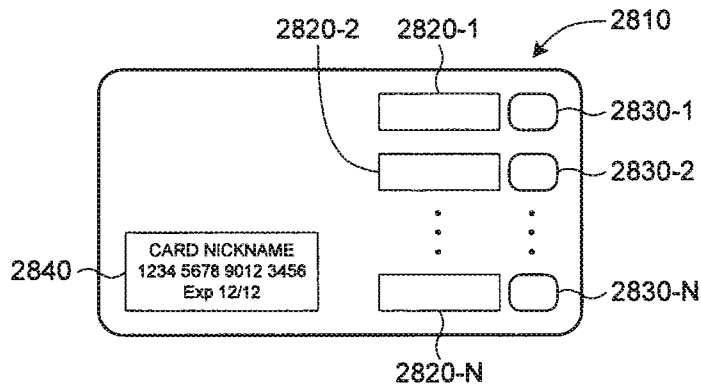
**FIGURE 25B**



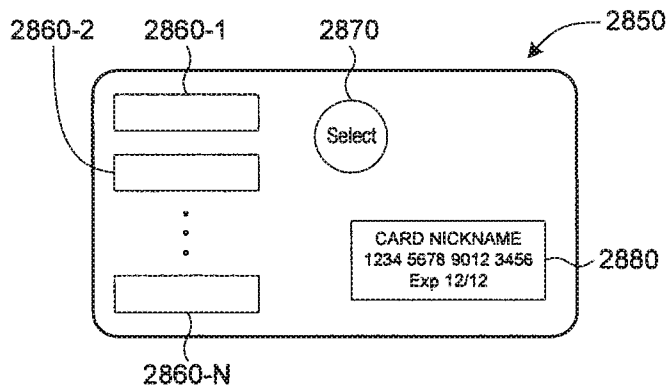
**FIGURE 26**



**FIGURE 27**

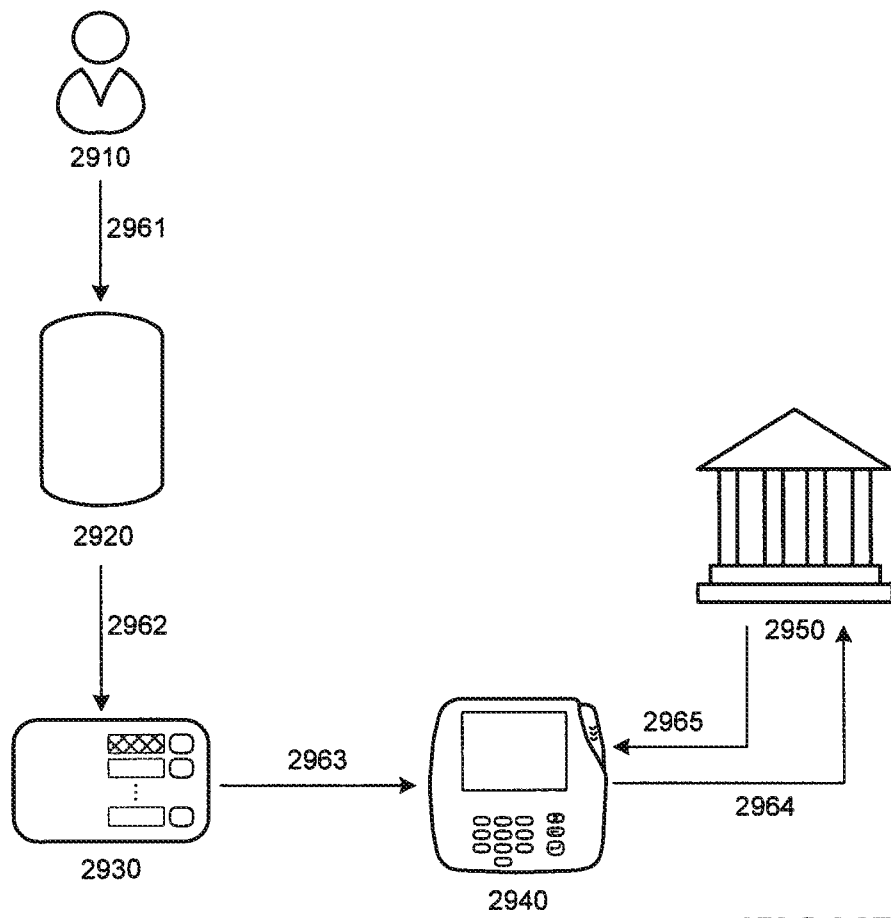


**FIGURE 28A**

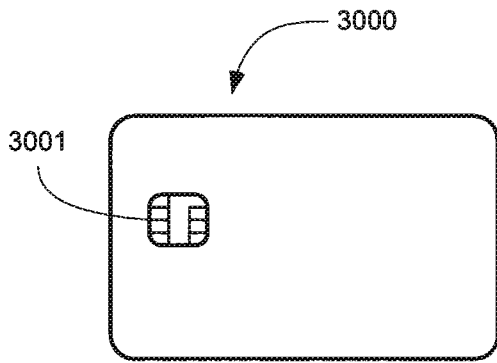


**FIGURE 28B**

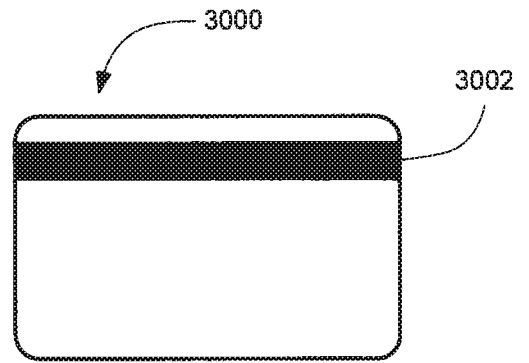




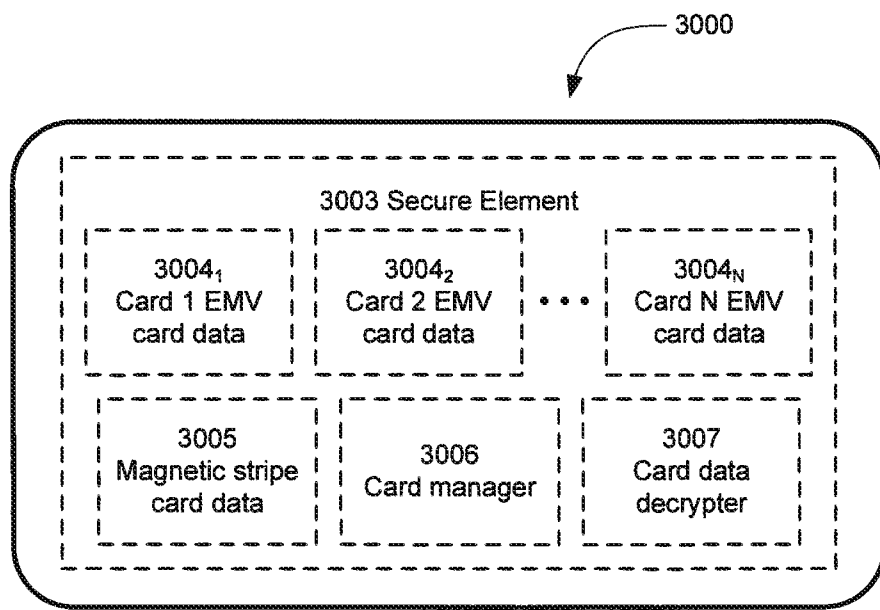
**FIGURE 29**



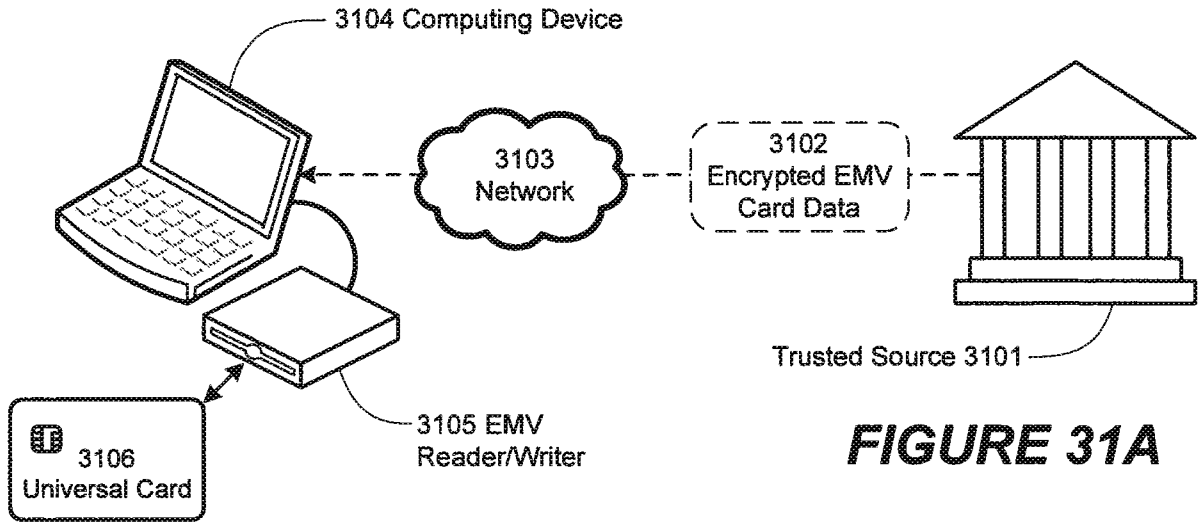
**FIGURE 30A**



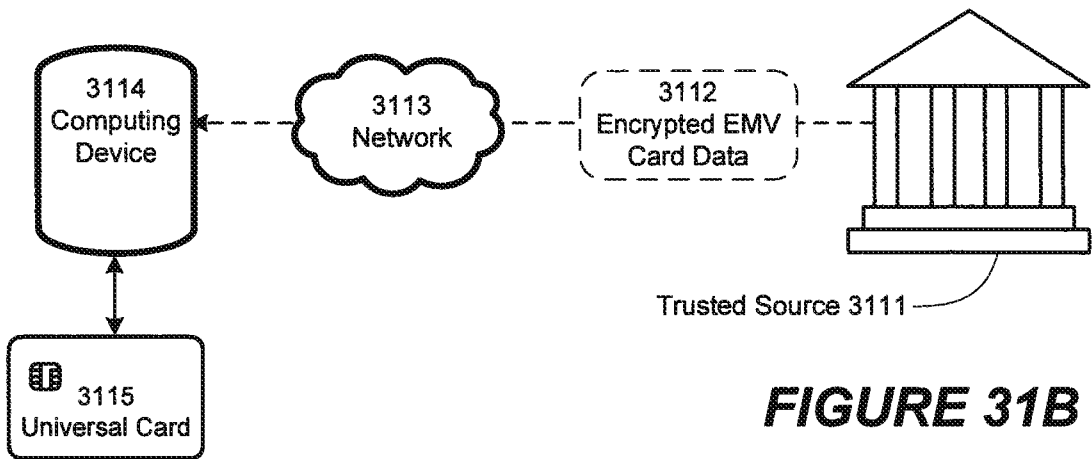
**FIGURE 30B**



**FIGURE 30C**

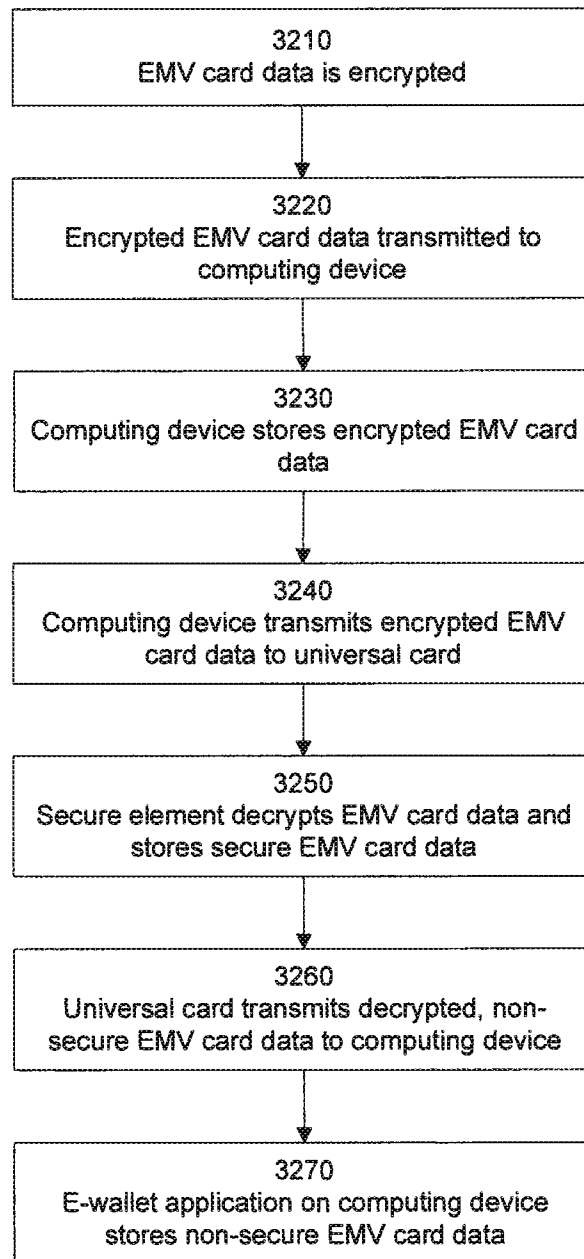


**FIGURE 31A**



**FIGURE 31B**

34/34

**FIGURE 32**

## INTERNATIONAL SEARCH REPORT

International application No.

PCT/US2013/023149.

<b>A. CLASSIFICATION OF SUBJECT MATTER</b> IPC(8) - G06K 1/18 (2013.01) USPC - 705/41 According to International Patent Classification (IPC) or to both national classification and IPC		
<b>B. FIELDS SEARCHED</b> Minimum documentation searched (classification system followed by classification symbols) IPC(8) - G06F 21/78; G06K 1/14, 1/18; G06Q 20/34, 20/36 (2013.01) USPC - 235/379, 380; 705/41, 51, 64, 65 Documentation searched other than minimum documentation to the extent that such documents are included in the fields searched CPC - G06F 21/78; G06K 1/14, 1/18; G06Q 20/34, 20/341, 20/3552, 20/3555, 20/36, 20/367, 20/3672 Electronic data base consulted during the international search (name of data base and, where practicable, search terms used) PatBase, Orbit, Google Patent, Google Scholar		
<b>C. DOCUMENTS CONSIDERED TO BE RELEVANT</b>		
Category*	Citation of document, with indication, where appropriate, of the relevant passages	Relevant to claim No.
X --- Y	US 2011/0218911 A1 (SPODAK) 08 September 2011 (08.09.2011) entire document	131-142 --- 1-98, 111-130, 143-174
Y	US 2010/0057580 A1 (RAGHUNATHAN) 04 March 2010 (04.03.2010) entire document	1-33, 38, 44, 49, 54, 59, 64
Y	US 2006/0190412 A1 (OSTROFF) 24 August 2006 (24.08.2006) entire document	78-130
Y	US 2010/0280948 A1 (COHEN) 04 November 2010 (04.11.2010) entire document	99-110
Y	US 2009/0103732 A1 (BENTEO et al.) 23 April 2009 (23.04.2009) entire document	34-77, 143-174
Y	US 2005/0116026 A1 (BURGER et al.) 02 June 2005 (02.06.2005) entire document	34-77, 143-174
Y	US 2011/0219026 A1 (SCHONEMANN) 08 September 2011 (08.09.2011) entire document	5-8, 10, 16-19, 21, 27-30, 32
Y	US 2009/0199206 A1 (FINKENZELLER et al.) 06 August 2009 (06.08.2009) entire document	143-174
<input type="checkbox"/> Further documents are listed in the continuation of Box C. <input type="checkbox"/>		
* Special categories of cited documents: "A" document defining the general state of the art which is not considered to be of particular relevance "E" earlier application or patent but published on or after the international filing date "L" document which may throw doubts on priority claim(s) or which is cited to establish the publication date of another citation or other special reason (as specified) "O" document referring to an oral disclosure, use, exhibition or other means "P" document published prior to the international filing date but later than the priority date claimed "T" later document published after the international filing date or priority date and not in conflict with the application but cited to understand the principle or theory underlying the invention "X" document of particular relevance; the claimed invention cannot be considered novel or cannot be considered to involve an inventive step when the document is taken alone "Y" document of particular relevance; the claimed invention cannot be considered to involve an inventive step when the document is combined with one or more other such documents, such combination being obvious to a person skilled in the art "&" document member of the same patent family		
Date of the actual completion of the international search 21 May 2013		Date of mailing of the international search report <b>05 JUN 2013</b>
Name and mailing address of the ISA/US Mail Stop PCT, Attn: ISA/US, Commissioner for Patents P.O. Box 1450, Alexandria, Virginia 22313-1450 Facsimile No. 571-273-3201		Authorized officer: Blaine R. Copenheaver PCT Helpdesk: 571-272-4300 PCT OSP: 571-272-7774

INTERNATIONAL SEARCH REPORT

International application No.

PCT/US2013/023149

Box No. II Observations where certain claims were found unsearchable (Continuation of item 2 of first sheet)

This international search report has not been established in respect of certain claims under Article 17(2)(a) for the following reasons:

- 1.  Claims Nos.:  
because they relate to subject matter not required to be searched by this Authority, namely:
  
- 2.  Claims Nos.:  
because they relate to parts of the international application that do not comply with the prescribed requirements to such an extent that no meaningful international search can be carried out, specifically:
  
- 3.  Claims Nos.:  
because they are dependent claims and are not drafted in accordance with the second and third sentences of Rule 6.4(a).

Box No. III Observations where unity of invention is lacking (Continuation of item 3 of first sheet)

This International Searching Authority found multiple inventions in this international application, as follows:

See extra sheet.

- 1.  As all required additional search fees were timely paid by the applicant, this international search report covers all searchable claims.
- 2.  As all searchable claims could be searched without effort justifying additional fees, this Authority did not invite payment of additional fees.
- 3.  As only some of the required additional search fees were timely paid by the applicant, this international search report covers only those claims for which fees were paid, specifically claims Nos.:
  
- 4.  No required additional search fees were timely paid by the applicant. Consequently, this international search report is restricted to the invention first mentioned in the claims; it is covered by claims Nos.:

Remark on Protest

- The additional search fees were accompanied by the applicant's protest and, where applicable, the payment of a protest fee.
- The additional search fees were accompanied by the applicant's protest but the applicable protest fee was not paid within the time limit specified in the invitation.
- No protest accompanied the payment of additional search fees.

INTERNATIONAL SEARCH REPORT

International application No.

PCT/US2013/023149

This application contains the following inventions or groups of inventions which are not so linked as to form a single general inventive concept under PCT Rule 13.1. In order for all inventions to be examined, the appropriate additional examination fees must be paid.

Group I, claims 1-33, drawn to providing data to a universal card comprising receiving a request that card data be sent to a recipient device, identifying the recipient device and delivering the card data to the recipient device via a network

Group II, claims 34-98, 111-174, drawn to receiving data in an encrypted format comprising secure and non-secure card data, wherein the universal card includes a secure element configured to decrypt the data to obtain decrypted secure and non-secure card data, storing the secure decrypted data in the secure element, storing the decrypted non-secure data in the computing device, which comprises an e-wallet application permitting user selection of a card, wherein the card is configured to configure a dynamic data communication mechanism of the card to emulate static data communication mechanism using the decrypted secure card data

Group III, claims 99-110, drawn to receiving by a proxy card server from a first device a request to disable a universal card from being used as a proxy card, receiving by a proxy card server from a second device, a request to authorize a payment transaction an determining that the data is associated with the universal card, and transmitting to the second device an indication that the transaction is unauthorized

The inventions listed as Groups I, II and III do not relate to a single general inventive concept under PCT Rule 13.1 because, under PCT Rule 13.2, they lack the same or corresponding special technical features for the following reasons: the special technical feature of the Group I invention: providing data to a universal card comprising receiving a request that card data be sent to a recipient device, identifying the recipient device and delivering the card data to the recipient device via a network as claimed therein is not present in the invention of Groups II and III. The special technical feature of the Group II invention: receiving data in an encrypted format comprising secure and non-secure card data, wherein the universal card includes a secure element configured to decrypt the data to obtain decrypted secure and non-secure card data, storing the secure decrypted data in the secure element, storing the decrypted non-secure data in the computing device, which comprises an e-wallet application permitting user selection of a card, wherein the card is configured to configure a dynamic data communication mechanism of the card to emulate static data communication mechanism using the decrypted secure card data as claimed therein is not present in the invention of Groups I or III. The special technical feature of the Group III invention: receiving by a proxy card server from a first device a request to disable a universal card from being used as a proxy card, receiving by a proxy card server from a second device, a request to authorize a payment transaction an determining that the data is associated with the universal card, and transmitting to the second device an indication that the transaction is unauthorized as claimed therein is not present in the invention of Groups I or II.

Groups I, II and III lack unity of invention because even though the inventions of these groups require the technical feature of initiating proxy card transactions using a universal card comprising handling card data, receiving card data by a computing device and transmitting the card data from the computing device to a universal card, and authorizing a payment transaction using a proxy card comprising passing card data from a universal card to a terminal, this technical feature is not a special technical feature as it does not make a contribution over the prior art in view of US 2011/0218911 A1 (SPODAK) 08 September 2011 (08.09.2011), Abstract, Figures 1, 4-5, paragraphs 17-20, 43-44, 46-50.

Since none of the special technical features of the Group I, II or III inventions are found in more than one of the inventions, unity of invention is lacking.