

**(12) STANDARD PATENT APPLICATION (11) Application No. AU 2013206427 A1**  
**(19) AUSTRALIAN PATENT OFFICE**

(54) Title  
**System and method of analyzing web addresses**

(51) International Patent Classification(s)  
**H04L 29/06** (2006.01) **H04L 12/22** (2006.01)  
**G06F 17/30** (2006.01)

(21) Application No: **2013206427** (22) Date of Filing: **2013.06.20**

(43) Publication Date: **2013.07.11**

(43) Publication Journal Date: **2013.07.11**

(62) Divisional of:  
**2007328397**

(71) Applicant(s)  
**Websense, Inc.**

(72) Inventor(s)  
**HUBBARD, Dan;TSE, Alan**

(74) Agent / Attorney  
**FB Rice, Level 23 44 Market Street, SYDNEY, NSW, 2000**

ABSTRACT

A system and method are provided for identifying active content in websites on a network. One embodiment includes a method of classifying web addresses. One embodiment may include a method of generating a score indicative of the reputation, or likelihood that a web site associated with an uncategorized URL contains active or other targeted content based on an analysis of the URL. In certain embodiments, the score is determined solely from the URL string. Other embodiments include systems configured to perform such methods.

2013206427 20 Jun 2013

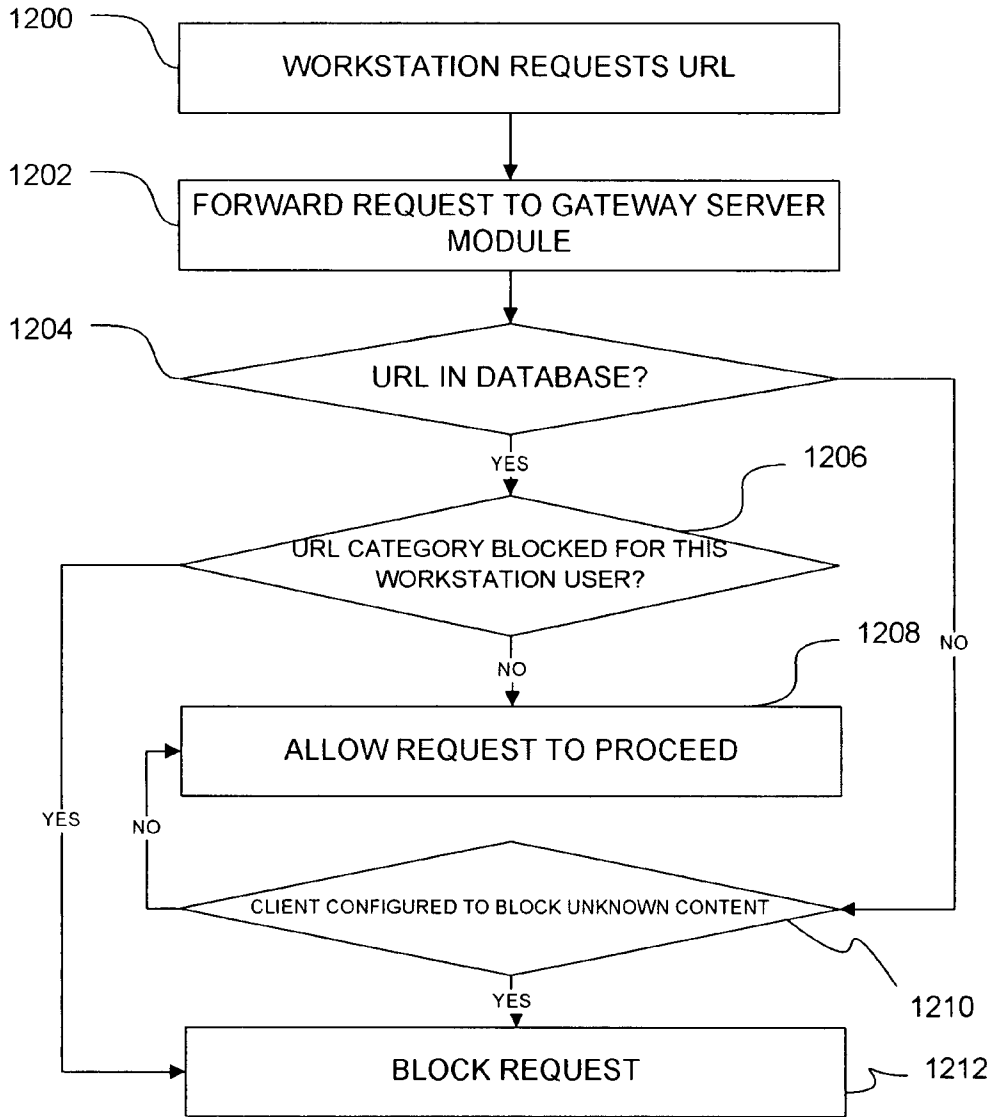

FIG. 16

**AUSTRALIA**

**Patents Act 1990**

**WEBSENSE, INC.**

**COMPLETE SPECIFICATION  
STANDARD PATENT**

*Invention Title:*

*System and method of analyzing web addresses*

The following statement is a full description of this invention including the best method of performing it known to us:-

2013206427 20 Jun 2013

## SYSTEM AND METHOD OF ANALYZING WEB ADDRESSES

## RELATED APPLICATIONS

[0001] This application claims the benefit of, and incorporates by reference in its entirety, U.S. Provisional Application no. 60/868305, filed December 1, 2006.

## BACKGROUND OF THE INVENTION

Field of the Invention

[0002] This application relates to data and application security. In particular, this application discloses systems methods of collecting and mining data to predict the content or nature of a web site based on its web address.

Description of the Related Technology

[0003] Traditionally, computer viruses and other malicious content were most often provided to client computers by insertion of an infected diskette or some other physical media into the computer. As the use of e-mail and the Internet increased, e-mail attachments became a prevalent method for distributing virus code to computers. To infect the computer with these types of viruses having malicious content, some affirmative action was typically required by the user such as opening an infected file attachment or downloading an infected file from a web site and launching it on their computer. Over time, antivirus software makers developed increasingly effective programs designed to scan files and disinfect them before they had the opportunity to infect client computers. Thus, computer hackers were forced to create more clever and innovative ways to infect computers with their malicious code.

[0004] In today's increasingly-networked digital world, distributed applications are being developed to provide more and more functionality to users in an open, collaborative networking environment. While these applications are more powerful and sophisticated, their increased functionality requires that network servers interact with client computers in a more integrated manner. For example, where previous web applications primarily served HTML content to client browsers and received data back from the client via HTTP post

2013206427 20 Jun 2013

commands, many new web applications are configured to send various forms of targeted content, such as active content, to the client computer which cause applications to be launched within the enhanced features of newer web browsers. For example, many web-based applications now utilize Active-X controls which must be downloaded to the client computer so they may be effectively utilized. Java applets, JavaScript, and VBScript commands also have the capability of modifying client computer files in certain instances.

[0005] The convenience that has arrived with these increases in functionality has not come without cost. Newer web applications and content are significantly more powerful than previous application environments. As a result, they also provide opportunities for malicious code to be downloaded to client computers. In addition, as the complexity of the operating system and web browsing applications increase, it becomes more difficult to identify security vulnerabilities which may allow hackers to transfer malicious code to client computers. Although browser and operating system vendors generally issue software updates to remedy these vulnerabilities, many users have not configured their computers to download these updates. Thus, hackers have begun to write malicious code and applications which utilize these vulnerabilities to download themselves to users' machines without relying on any particular activity of the user such as launching an infected file. One example of such an attack is the use of malicious code embedded into an active content object on a website. If the malicious code has been configured to exploit a vulnerability in the web browser, a user may be infected or harmed by the malicious code as a result of a mere visit to that page, as the targeted content in the page will be executed on the user's computer.

[0006] An attempt to address the problem of malicious code being embedded in active content is to utilize heightened security settings on the web browser. However, in many corporate environments, intranet or extranet applications are configured to send executable content to client computers. Setting browser settings to a high security level tends to impede or obstruct the effective use of these types of "safe" applications. Another attempt to address the issue is to block all executable content using a network firewall application. This brute force approach also is ineffective in many environments, because selective access to certain types of content is necessary for software to correctly function.

## SUMMARY OF CERTAIN INVENTIVE ASPECTS

[0007] The system, method, and devices of the invention each have several aspects, no single one of which is solely responsible for its desirable attributes. Without limiting the scope of this invention as expressed by the claims which follow, its more prominent features will now be discussed briefly. After considering this discussion, and particularly after reading the section entitled "Detailed Description of Certain Inventive Embodiments" one will understand how the features of this invention provide advantages that include improved detection of web sites having targeted content.

[0008] One embodiment includes a method of controlling access to web content. The method comprises receiving a request for at least one uniform resource locator (URL). The method further comprises generating an indicator of active content associated with the URL. The indicator is based on data associated with at least one component of the URL. The method further comprises determining whether to allow the request based at least partly on the at least indicator.

[0009] Another embodiment includes a system for controlling access to web content. The system comprises a gateway server module configured to receive a request for at least one uniform resource locator. The system further comprises a URL analysis module configured to generate an indicator of active content associated with the URL. The indicator is based on data associated with at least one component of the URL. The system further comprises a policy module configured to identify a policy associated with the URL. The system further comprises a content filtering module configured to determine whether to allow the request based at least partly on the at least indicator and the policy.

[0010] One embodiment includes a system for controlling access to web content. The system comprises means for receiving a request for at least one uniform resource locator. The system further comprises means for generating an indicator of active content associated with the URL. The indicator is based on data associated with at least one component of the URL. The system further comprises means for identifying a policy associated with the URL. The system further comprises means for determining whether to allow the request based at least partly on the at least indicator and the policy.

## BRIEF DESCRIPTION OF THE DRAWINGS

[0011] In this description, reference is made to the drawings wherein like parts are designated with like numerals throughout.

[0012] FIG. 1 is a block diagram of various components of a system in accordance with aspects of the invention.

[0013] FIG. 2 is a block diagram of a workstation module from Figure 1.

[0014] FIG. 3 is a block diagram of a gateway server module from Figure 1.

[0015] FIG. 4 is an example of a logging database.

[0016] FIG. 5 is an example of a URL Access Policy database table.

[0017] FIGS. 6A and 6B are examples of categorized and uncategorized URLs, respectively.

[0018] FIG. 7 is a block diagram of a database management module from Figure 1.

[0019] FIG. 8 is a block diagram of a collection system from Figure 7.

[0020] FIG. 9 is a block diagram of a collection module from Figure 8.

[0021] FIG. 10 shows a honey client system according to some aspects of the invention.

[0022] FIG. 11 is an example of URL-related data collected by the collection module from Figure 9.

[0023] FIG. 12 is a block diagram illustrating a scoring and categorization module from Figure 7.

[0024] FIG. 13A is an example of a properties table.

[0025] Figure 13B is an example of a processed web page properties table.

[0026] Figure 13C is an example of a definitions table.

[0027] FIG. 14 is a block diagram illustrating one embodiment of a training module from Figure 7.

[0028] FIG. 15 is a block diagram illustrating one embodiment of an active analysis system from Figure 12.

[0029] FIG. 16 is a flowchart describing how URLs may be handled in the gateway server module in one embodiment.



[0030] FIG. 17 is a flowchart describing how URLs may be handled by the gateway server module in conjunction with the policy module according to certain embodiments.

[0031] FIG. 18 is a flowchart describing the how the collection system may handle a URL within the gateway server module.

[0032] FIG. 19 is a flowchart describing the how the collection system may handle a URL within the database management module.

[0033] FIG. 20 is a block diagram of a data mining system.

[0034] FIG. 21 is a flowchart illustrating one embodiment of a method of categorizing URLs within the database management module.

[0035] FIG. 22 is a flowchart illustrating one embodiment of a method of identifying properties of a URL in the method of Figure 21.

[0036] FIG. 23 is a flowchart illustrating one embodiment of a method of categorizing URLs based on URL properties in the method of Figure 21.

[0037] FIG. 24 is a flowchart illustrating one embodiment of a method of identifying properties used in categorizing URLs in the methods of Figures 22 and 23.

[0038] Fig. 25 is a flowchart illustrating one embodiment of a method of controlling access to web content based on an indicator associated with a requested web address.

#### DETAILED DESCRIPTION OF CERTAIN INVENTIVE EMBODIMENTS

[0039] The following detailed description is directed to certain specific embodiments of the invention. However, the invention can be embodied in a multitude of different ways as defined and covered by the claims. In this description, reference is made to the drawings wherein like parts are designated with like numerals throughout.

[0040] Certain embodiments provide for systems and method of identifying and categorizing web content, including potentially executable web content and malicious content, that is found at locations identified by Uniform Resource Locators (URLs). As used herein, potentially executable web content generally refers to any type of content that includes instructions that are executed by a web browser or web client computer. Potentially executable web content may include, for example, applets, executable code embedded in

2013206427 20 Jun 2013

HTML or other hypertext documents (including script languages such as JavaScript or VBScript), executable code embedded in other documents, such as Microsoft Word macros, or stylesheets. Potentially executable web content may also refer to documents that execute code in another location such as another web page, another computer, or on the web browser computer itself. For example, a HTML web page that includes an “OBJECT” element, and thus can cause execution of ActiveX or other executable components, may generally be considered potentially executable web content regardless of the location of the executable components. Malicious content may refer to content that is not executable but which is calculated to exploit a vulnerability on a client computer. However, potentially executable web content may also be malicious content. For example, image files have been used to exploit vulnerabilities in certain operating systems when those images are processed for display. Moreover, malicious web content may also refer to interactive content such as “phishing” schemes in which a HTML form or other web content is designed to appear to be provided by another, typically trusted, web site such as a bank, in order to deceive the user into providing credentials or other sensitive information to an unauthorized party.

#### Description of System

[0041] Figure 1 provides a top level illustration of an exemplary system. The system includes a network 110. The network 110 may be a local area network, a wide area network, or some other type of network. The network 110 may include one or more workstations 116. The workstations 116 may be various types of client computers that are attached to the network. The client computers 116 may be desktop computers, notebook computers, handheld computers or the like. The client computers may also be loaded with operating systems that allow them to utilize the network through various software modules such as web browsers, e-mail programs, or the like.

[0042] Each of the workstations 116 may be in electrical communication with a gateway server module 120. The gateway server module may reside at the edge of the network 110 so that traffic sent to and from the Internet 112 may pass through it on its way into or out of the network 110. The gateway server module 120 may take the form of a software module that is installed on a server that stands as a gateway to a wider area network 112 than the network 110 to which the workstations 116 are directly attached. Also

connected to the Internet 112 is a database management module 114. The database management module also may be a software module (or one or more hardware appliances) which resides on one or more computing devices. The database management module 114 may reside on a machine that includes some sort of network connecting hardware, such as a network interface card, which allows the database management module 114 to send and receive data and information to and from the Internet 112.

[0043] In the example system of Figure 1, one or more of the work stations 116 may be in communication with one or more search engines 113 via the Internet 112. The search engine 113 is typically a web site which receives user requests for information and websites which are relevant to the parameters of the submitted user requests. Well known examples of search engines are Google, Yahoo, and Ask.com.

[0044] In the example system of Figure 1, one or more of the work stations 116 may be in communication with one or more syndicated websites 115 via the Internet 112. The syndicated website 115 offers a web feed of content from the website. Typically, the content from the syndicated website 115 is accessed by web feed readers installed on client workstations 116.

[0045] Referring now to Figure 2, a more detailed view of the workstation 116 is presented. The workstation 116 may include a workstation module 130. The workstation module 130 may take the form of software installed to run on the operating system of the workstation 116. Alternatively, the workstation module 130 could be an application running on another machine that is launched remotely by the workstation 116.

[0046] The workstation module 130 may include various components. The workstation module may include an inventory of a local active content module 132 which records all web content stored on the workstation 116. For example, the local content inventory module 132 may periodically inventory all local content. The inventoried data may be uploaded to the gateway server module 120 for comparison to a categorized URL/content database 146, which is discussed below in more detail. The local content inventory module 132 may determine whether new content is being introduced to the workstation 116 by comparison to the inventoried local content contained therein.

2013206427 20 Jun 2013

[0047] The workstation module 130 also may include one or more upload/download modules 134 and one or more URL request modules 136. The upload/download modules 134 may be used to send and receive data from the network 110, through the gateway server module 120 and to the Internet 112. The URL request module 136 may receive a data request from either a user or some system process, and send the request via the gateway server module 120 to retrieve the file and/or content associated with the request. The request may be a search engine request made to the search engine 113. In response to the search, the search engine 113 may return one website or a list of websites (and URL links leading to those websites) based on the search parameters. The request may also be a content request made to the syndicated website 115. In response to the request, the syndicated website 115 may return one URL link or a list of URL links to the requested content. For ease of explanation, the term network request is used to include user requests for content via the search engine 113 or requests sent via a web feed reader to the syndicated website 115. The system of Figure 1 monitors and/or modifies the data returned in response to the network request to inhibit objectionable or malicious content from being available to the user.

[0048] Typically, the functions of each of the upload/download modules 134 and the URL request modules 136 are performed by software applications such as web browsers, with Internet Explorer®, Mozilla Firefox, Opera, Safari, being examples of browsing software well-known in the art. These functions may also be performed by other types of software such as web feed readers, instant messaging programs, peer-to-peer file sharing applications, digital media player applications (e.g., iTunes®, RealPlayer, Quicktime), or some other applications.

[0049] Alternatively, the functions of the modules may be divided among different software applications. For example, an FTP application may perform the functions of the upload/download module 134, while a web browser performs the functions of sending requests to the search engine. A web feed reader application may send a request for content to the syndicated website 115. Other types of software may also perform the functions of the upload/download module 134. Although these types of software are generally not desirable

2013206427 20 Jun 2013

on a workstation, software such as Spyware, or Trojan Horses may make requests to send and receive data from the Internet.

[0050] The workstation module 130 may be in communication with the gateway server module 120. The gateway server module 120 may be used to analyze incoming and outgoing web traffic and to make various determinations about the impact the traffic may have on the workstations 116. Referring now to Figure 3, an example of the gateway server module 120 is provided. The gateway server module 120 is in two way communication with the workstation 116. It may receive file uploads and downloads and URL requests from the workstation module 130. The gateway server module 120 is also in two way communication with the Internet 112. Thus, requests originating within the workstations 116 of the network 110 may be required to pass through the gateway server module 120 as they proceed to the Internet. In some embodiments, the gateway server module 120 may be integrated with some firewall hardware or software that protects the network 110 from unauthorized intrusions from the Internet 112. In other embodiments, the gateway server module 120 may be a standalone hardware appliance or even a software module installed on a separate gateway server residing at the network gateway to the Internet 112.

[0051] As discussed above, the gateway server module 120 may receive URL requests and upload/download data from the workstation 116 by way of the workstation module 130. The gateway server module 120 may include various components that perform various functions based on the data received.

[0052] One feature included in the gateway server module 120 is the categorized URL/content database 146. The URL database 146 may be used to store information about URLs including data that is associated with the URLs. The categorized URL/content database 146 may be a relational database, or it may be stored in some other form such as a flat file, an object-oriented database, and may be accessed via an application programming interface (API), or some database management software (DBMS). The URL database 146 may generally be used to help determine whether URL requests sent by the URL request module 136 will be permitted to be completed. In one embodiment, the URLs stored in the URL database 146 are categorized.

2013206427 20 Jun 2013

[0053] The gateway server module 120 may also include a policy module 142. The policy module 142 may be used to implement network policies regarding how certain content will be handled by the gateway server module 120 or by a firewall or some other security software installed within the network 110. In one embodiment, the policy module 142 may be configured to provide the system guidance on how to handle URL requests for categorized URLs. For example, the gateway server module 120 may be configured to disallow URL requests that are categorized as being "Malicious" or "Spyware." In other embodiments, the policy module 142 may be used to determine how to handle URL requests that have not been categorized. In one embodiment, the system may be configured to block all requests for URLs that are not in the categorized URL/content database 146. The policy module 142 may also be configured to allow certain requests of uncategorized URLs based on the user making the request or the time at which the request is made. This allows the system to avoid having a one-size-fits-all configuration when such a configuration would not meet the business needs of the organization running the gateway server module 120.

[0054] The gateway server module 120 may include a collection module 140. The collection module 140 may be a software program, routine, or process that is used to collect data about URLs. In one embodiment, when an internet request is received from the URL request module 136 for content from the syndicated website 115, the collection module 140 may be configured to visit the website associated with the syndicated website 115 and download data to the gateway server module 120 for analysis by components of the gateway server module 120. The downloaded data may also be sent via the Internet 112 for delivery to the database management module 114 (as will be discussed in further detail below).

[0055] In some embodiments, the gateway server module 120 may also include a logging database 144. The logging database 144 may perform various functions. For example, it may store records of certain types of occurrences within the network 110. In one embodiment, the logging database 144 may be configured to record each event in which an uncategorized URL is requested by a workstation 116. In some embodiments, the logging database 144 may also be configured to record the frequency with which a particular uncategorized URL is requested. This information may be useful in determining whether an uncategorized URL should be of particular importance or priority and should be categorized

2013206427 20 Jun 2013

by the database management module 114 ahead of earlier received data. In some embodiments, uncategorized URLs may be stored separately in an uncategorized URL database 147.

[0056] For example, some spyware may be written to request data from a particular URL. If many workstations 116 within the network 110 are infected with the spyware, repeated requests to a particular URL may provide an indication that some anomaly is present within the network. The logging database may also be configured to record requests of categorized URL data. In some embodiments, categorizing requests of categorized URLs may be helpful in determining whether a particular URL has been mischaracterized.

[0057] Referring now to Figure 4, an example of the logging database 144 is discussed. The logging database 144 includes four columns of data. The first column, "No. Page Requests" 152 is indicative of the number of times a particular URL has been requested by users within the network 110. The second column "URL" 154 records the particular URL string that is being logged in the logging database 144. Thus, when a URL is sent to the logging database 144, the database may first be searched to determine whether the URL string is already in it. If not, then the URL string may be added to the database. In some embodiments, the collection module 140 may be configured to visit the requested URL and gather data about the URL. The collection module 140 may retrieve the page source of the requested URL and scan it for certain keywords that may indicate a type of content. For example, if the page source includes "javascript:/" then the page may be identified as having JavaScript. While such content is not inherently dangerous, a web page with JavaScript may have a greater chance of including malicious content designed to exploit how a browser application handles JavaScript function calls. In some embodiments, this data may be stored in the logging database 144 in JavaScript column 155. The logging database may also receive similar information from pages that include Active-X content and store that content within Active X column 156. In other embodiments, other types of active content may be detected and stored for java applets, VBScript, and the like.

[0058] Referring again to Figure 3, the gateway server module 120 may further include an IT interface module 148. The interface module 148 may be used to allow network

2013206427 20 Jun 2013

administrators or other technical personnel within an organization to configure various features of the gateway server module 120. In certain embodiments, the interface module 148 allows the network administrator or some other network management-type to configure the policy module 142.

[0059] The gateway server module 120 may further comprise a URL analysis module 149. The URL analysis module 149 is configured to analyze URLs based on the URL and data associated with the URL. Data associated with a URL may include reputation data. Examples of web reputation data include data associated with the URL host and the URL host nameserver. Additional examples of web reputation data are discussed below with reference to the URL analysis module 149.

[0060] The gateway server module 120 may also include a content filtering module 150. The content filtering module 150 may work in conjunction with the policy module and the categorized URL/content database 146 to filter portions of search results returned in response to a network request. In one embodiment, the content filtering module 150 may be configured to remove URL links and other content from a list of URLs returned in response to a user query sent to an Internet search engine 113. By way of example and not of limitation, the content filtering module 150 may be configured to recognize an outgoing search engine query. A page returned by the search engine 113 to the client workstation 116 may be intercepted by the gateway server module 120 and analyzed by the content filtering module 150. The content filtering module 150 may be configured to parse the returned page and identify URL links in the returned search results and embedded items of content such as images or active content.

[0061] Each identified URL link or item of content may be compared to the data in the URL/content database 146 to determine if the URL link has already been categorized. If it has been categorized, the policy module is consulted for instructions on how to handle the content. For example, the policy module 142 may instruct the content filtering module 150 to remove URL links that lead to web pages that are categorized as being "Malicious" or "Spyware." In addition, the content filtering module 150 may also be configured to remove objectionable content from the returned search engine results based on the presence and categorization of the content in the URL/content database 146. In one embodiment, the



content filtering module 150 may be configured to filter content based on information provided by the URL analysis module 149.

[0062] Referring now to Figure 5, an example of a URL access policy database 158 is provided. The URL access policy database 158 may be used by the policy module 142 to implement policies for accessing web-based content by workstations 116 within the network 110. In the embodiment shown the URL access policy database 158 includes a table with four columns. The first column is a user column 160. The “User” column 160 includes data about the users that are subject the policy defined in a given row of the table. The next column, “Category” 162, lists the category of content to which the policy defined by that row is applicable. The third column, “Always Block” 164 represents the behavior or policy that is implemented by the system when the user and category 162 of requested content match the user and category as defined in that particular row. In one embodiment, the “Always Block” field may be a Boolean-type field in which the data may be set to either true or false. Thus, in the first row shown in the data table, the policy module 142 is configured to “always block” requests for “malicious content” by user “asmith.”

[0063] As noted above, the policy module 142 may also be configured to implement policies based on different times. In the embodiment provided in Figure 5, the fourth column “Allowed Times” 166 provides this functionality. The second row of data provides an example of how time policies are implemented. The user 164 is set to “bnguyen” and the category 162 is “gambling.” The policy is not configured to “always block” gambling content for “bnguyen,” as indicated by the field being left blank. However, the time during which these URL requests are permitted is limited to from 6PM to 8AM. Thus, adopting these types of policies allows network administrators to provide a certain degree of flexibility to workstations and users, but to do so in a way that network traffic is not compromised during typical working hours.

[0064] In one embodiment, the URL analysis module 149 may be configured to examine requested URLs, e.g., URLs not previously categorized and generate a score or other data indicative of whether the URL is likely to reference targeted (e.g., active) content. In one embodiment, the URL analysis module 149 may comprise a reputation scoring module

(such as an embodiment of the reputation scoring module 331 of Figure 12) that generates a score or other data representative of a reputation of the URL.

[0065] When located within the gateway server module 120, the reputation scoring module of the URL analysis module 149 may directly analyze the reputation of the URL using local data and databases to determine a score with minimal latency. The reputation scoring module may communicate with one or more databases of the database management module 114 (see Figure 1) to obtain additional information about the URL or components of the URL for determining a score for the URL.

[0066] The URL analysis module 149 need not include the reputation scoring module and instead may rely upon a remotely located reputation scoring module. For example, a reputation scoring module 331 may be located at the database management module 114 as is illustrated in the embodiment of the database management module 114 in Figures 7 and 12. The URL analysis module 149 communicates the requested URL to the database management module 114 for scoring by the remotely located reputation scoring module 331. The database management module 114 communicates the results of the analysis performed by the reputation scoring module 331 back to the gateway sever module 120. The gateway server module 120 may rely upon the results received from the database management module 114 to determine under what conditions the user will be allowed access to the website associated with the requested URL. The gateway server module 120 may further rely upon a predetermined policy associated with the user when determining whether access will be allowed. Advantageously, a remotely located reputation scoring module may be shared by multiple gateway server modules 120. A remotely located scoring module may reduce the complexity of the software needed at the gateway server module 120.

[0067] In other embodiments, the functionality of the reputation scoring module may be shared between the gateway server module 120 and the database management module 114. Such an arrangement may provide benefits to the latency of the scoring process while still providing the benefit of shared access.

[0068] For example, a higher reputation score may be indicative of the likelihood that the website associated with the URL does not include active content. URLs that are uncategorized might still have a high reputation score if the host internet protocol (IP)

2013206427 20 Jun 2013

address of the URL is the same (e.g., the hostname is merely an alias) as a host IP for which categorized URLs are not associated with active or other targeted content. Conversely, if the host IP address is the same as a host IP address that is associated with active or other targeted content, the reputation score may be low. Of course, depending on the embodiment, different score ranges, or different interpretations of scores (e.g., high scores indicative of a bad URL reputation) may be used.

[0069] It is to be recognized that data or a score indicative of the reputation of a URL may be based on one or more different data elements and analysis. Examples of ways of generating reputation scores are discussed below with reference to a reputation scoring module illustrated in Figure 12. The URL analysis module 149 may use one or more of the reputation scoring techniques described with reference to Figure 12 to generate a URL a score or other indicator of reputation.

[0070] A score indicative of a reputation may be generated for a URL requested by a user or for a URL requested by a proxy on behalf of the user. For example, applications such as web feed readers or other types of content aggregators collect data on behalf of a user through a single aggregating URL. Well known examples of these types of applications include Google Reader, <http://www.mynewsbot.com/>, MyYahoo!, NewsGator and the like. These types of applications typically allow a user of the workstation 116 to designate or “subscribe” to various external web sites that offer syndicated content. The web feed reader or aggregator visits each of the websites or URLs subscribed to by the user and gathers the syndicated content from the visited websites. Examples of known web feed protocols for gathering or aggregating syndicated content include RSS and ATOM. The syndicated content is often delivered to the aggregating website and displayed to the user under the aggregating protocol's URL. The aggregated content may be delivered to the aggregating website, for example, in the form of an XML package and includes URLs associated with the websites from where the content was gathered.

[0071] Unlike the website URLs, the aggregating protocol's URL under which the content is displayed is not specific to the user or to the gathered content. For example, content aggregated by yahoo's web feed reader is displayed under the URL “<http://my.yahoo.com>”. Because the single aggregating URL, such as

“http://my.yahoo.com”, is not specific to the user or gathered content, in one embodiment, the reputation scoring module 331 does not rely exclusively upon the aggregating URL to determine one or more reputation scores for the website URLs. In such an embodiment, the reputation scoring module 331, whether residing within or remote from the gateway server module 120, preferably relies upon an analysis of the website URLs associated with the gathered content to generate reputation scores. In one embodiment, the content filtering module 150 provides the website URLs associated with the gathered content to the URL analysis module. Each reputation score may then be unique to each website URL and relied upon by the gateway server module 120 to determine under what circumstances, if any, the user will be allowed to access the content associated with each scored website URL gathered by such types of web feed reader applications.

[0072] The gateway server module 120 may apply this same process to a listing of URLs returned in response to a search engine request. The gateway server module 120 analyzes each of the returned URLs to generate reputation scores. Each reputation score may then be unique to each listed URL and relied upon by the gateway server module 120 to determine under what circumstances, if any, the user will be allowed to access the content associated with each scored URL listed by the search engine.

[0073] The gateway server module 120 may also apply these technique to interactive websites and content. For example, in developing the web into more of a communication platform, several web properties are allowing interactive content uploads by end-users. Examples include, but are not limited to, MySpace, FaceBook, GooglePages, etc. The content on these sites is often based on active technologies such as JavaScript, XML, and Ajax. To analyze these types of pages and content, the gateway server module 120 may rely at least in part on the top-level category of the domain in combination with the analysis by the reputation scoring module 331 of the content and referenced links on the website.

[0074] The URL analysis module 149 may provide its score to the policy module 142. The policy module 142 can be configured to implement different policies depending on the score, the user, or any other applicable parameters. Thus, in one embodiment, the URL analysis module 149 may generate a sufficiently high reputation score (e.g., indicative of a good reputation or low likelihood of active or other targeted content) for an uncategorized

URL so that the policy module 142 allows access to the uncategorized URL when the policy module 142 would otherwise not allow access to the URL. Alternatively, the policy module 142 may be configured to block access to URLs with low scores (e.g., indicative of poor reputation or higher likelihood of active or other targeted content) where the applicable policy might otherwise allow access to the URL.

[0075] Figures 6A and 6B provide illustrations of how the categorized URL database 146 may store categorized data. In one embodiment, the categorized URLs may be stored in a two-column database table such as the one shown in Figure 6A. In one embodiment, the table may include a URL column 172 which may simply store the URL string that has been characterized. The Category column 174 may store data about the how that URL has been characterized by database module 114 (as will be described in detail below). In one embodiment, the URL field may be indexed so that it may be more quickly searched in real time. Because the list of categorized URLs may reach well into the millions of URLs, a fast access routine is beneficial.

[0076] Referring now to Figure 6B, the table of uncategorized URLs 147 is provided (described earlier in connection with Figure 3). This table may be populated by URL requests from the workstation 116 which request URLs that are not present in the categorized URL/content database 146. As will be described in greater detail below, the gateway server module 120 may be configured to query the categorized URL/content database 146 to determine whether a requested URL should be blocked. If the requested URL is in the categorized database 146, the policy module may determine whether to allow the request to proceed to the internet 112. If the requested URL is not found in the categorized URL/content database 146, however, it may be added to the database 147 of uncategorized URLs so that it may be sent to the database management module 114 via the Internet 112 and later analyzed and categorized and downloaded into the database of categorized URLs 146.

[0077] Figure 7 is an illustration of various components that may be included in the database management module 114. As discussed above, the database management module 114 may be located remotely (accessible via Internet 112) from the network 110 and its associated workstations 116. The database management module may take the form of one

or many different hardware and software components such as a server bank that runs hundreds of servers simultaneously to achieve improved performance.

[0078] In one embodiment, the database management module 114 may include an upload/download module 178. The upload/download module 178 may be a software or hardware component that allows the database management module 114 to send and receive data from the Internet 112 to any number of locations and may, depending on the embodiment, operate in a substantially similar manner as the upload/download module 134 on the gateway server module 120. In one embodiment, the upload/download module is configured to send newly categorized URLs to gateway server modules 120 on the Internet 112 for addition to their local categorized URL/content databases 146.

[0079] The database management module 114 may also include a database management module URL/content database 180. The database management module URL/content database 180 may take the form of a data warehouse which stores URL strings and information about URLs that have been collected by a collection system 182 which will be described in further detail below. The database management module URL/content database 180 may be a relational database that is indexed to provide quick and effective searches for data. In certain embodiments, the URL/content database 180 may be a data warehousing application which spans numerous physical hardware components and storage media. The URL/content database 180 may include data such as URL strings, the content associated with those strings, information about how the content was gathered (e.g., by a honey client, by a customer submission, etc.), and possibly the date in which the URL was written into the URL/content database 180.

[0080] The database management module 114 may further include a training system 184. The training system 184 may be a software/hardware module which is used to define properties and definitions that may be used to categorize web-based content. The database management module 114 may further provide a scoring/classification system 186 which utilizes the definitions and properties created by the training system 184 to provide a score or classification (e.g., a categorization) to web content so that the categorization may be delivered via the upload/download module 178 to gateway server modules 120.

2013206427 20 Jun 2013

[0081] With reference now to Figure 8, a more detailed view of the collection system 182 is provided. The collection system 182 may include a database management collection module 190 which is coupled (either directly or indirectly) to a data mining module 192. The database management collection module 190 may be used by the database management module 114 to collect data for the URL/content database 180 about URLs that have not been categorized. The database management collection module 190 may also be used to collect URLs for additional analysis by other system components. The database management collection module 190 may be associated with one or more collection sources 194 from which it may collect data about URLs. Collection sources 194 may take various forms. In some embodiments, the collection sources 194 may include active and passive honeypots and honey clients, data analysis of logging databases 144 stored on the gateway server module 120 to identify applications, URLs and protocols for collection. The collection sources 194 may also be webcrawling applications that search the Internet 112 for particular keywords or search phrases within page content. The collection sources 194 may also include URLs and IP addresses data mined from a DNS database to identify domains that are associated with known malicious IP addresses. In some embodiments, URLs for categorization may be collected by receiving malicious code and malicious URL samples from other organizations who share this information. In yet other embodiments, URLs may be collected via e-mail modules configured to receive tips from the public at large, much in the way that criminals are identified through criminal tip hotlines.

[0082] Referring now to Figure 9, a more detailed view of the database management collection module 190 is provided. The database management collection module 190 may include various subcomponents that allow it to effectively utilize each of the collection sources 194 described above. The database management collection module 190 may include a search phrase data module 197 and an expression data module 198. The search phrase data module 197 collects and provides search phrases that may be relevant to identifying inappropriate content. The expression data module 198 may include various types of expressions such as regular expressions, operands, or some other expression. The search phrase data module 197 and the expression data module 198 each may include updatable record sets that may be used to define the search parameters for the web crawling collection

2013206427 20 Jun 2013

source 194. The database management collection module 190 may also include a priority module 200. The priority module 200 may take the form of a software process running within the collection system 182, or it may run as a separate process. The priority module may be used to prioritize the data collected by the database management collection module in order to have more potentially dangerous or suspect URLs (or data) receive close inspection prior to the likely harmless URLs. In one embodiment, the priority module 200 may assign priority based on the collection source 194 from which the URL is received. For example, if a URL is received from a customer report, it may be designated with a higher priority. Similarly, if the URL is received from a web crawler accessing a domain or IP address or subnet known to host malicious content in the past, the URL may receive a high priority. Similarly, a potentially dangerous website identified by a honey client (discussed in further detail below) may also receive a high priority. The database management collection module 190 may also include a data selection module 202 which may work with the priority module 200 to determine whether identified URLs should be tagged as candidate URLs for categorization. In one embodiment, the data selection URL may provide a user interface for receiving search parameters to further refine the prioritized data by searching for data based on priority and content.

[0083] As indicated above, the collection module may also include a data download module 204. The data download module 204 may be configured to identify URLs to visit and to download data and content from the visited URLs. The data download module 204 may work in conjunction with various subsystems in the database management collection module 190 to retrieve data for the URL/content database 180. One such subsystem is the webcrawler module 206. The webcrawler module 206 may be a software application configured to access websites on the Internet 112 by accessing web pages and following hyperlinks that are included in those pages. The webcrawler module 206 may be configured with several concurrent processes that allow the module to simultaneously crawl many websites and report the visited URLs back to the database management module URL/content database 180 as will be discussed in further detail below. The database management collection module 190 may also include a honey client module 208. The honey client module 208 is a software process configured to mimic the behavior of a web browser to visit websites



in such a manner that is inviting to malicious code stored within the visited pages. The honey client module 208 may visit the web sites and track the behavior of the websites and download the content back to the URL/content database 180 for further analysis.

[0084] The database management collection module 190 may also include a third party supplier module 212 which is configured to receive URLs and associated content from third parties. For example, the third party module 212 may be configured to provide a website which may be accessed by the general public. The module may be configured to receive an input URL string which may then be entered into the URL/content database 180. In some embodiments, the third party module may also be configured to receive e-mails from private or public mailing lists, and to identify any URL data embedded within the e-mails for storage in the URL/content database 180.

[0085] The database management collection module 190 may also include a gateway server access module 210. The gateway server access module is a software component or program that may be configured to regularly access the logging database 144 on the gateway server module 120 to download/upload all of the newly uncategorized web content identified by the logging database 144.

[0086] Referring back to Figure 8, the collection system 182 may also include a data mining module 192. The data mining module 192 may be used to obtain additional data about URLs stored in the database management module's URL/content database 180. In many instances, the information supplied by the collection sources 194 to the database management collection module 190 and URL/content database 180 is limited to nothing more than a URL string. Thus, in order for the system to effectively categorize the content within that URL, more data may be necessary. For example, the actual page content may need to be examined in order to determine whether there is dangerous content embedded within the URL. The data mining module 192 is used to collect this additional necessary data about the URLs, and will be discussed in further detail below.

[0087] [0087] Figure 10 provides a more detailed view of a honey client system 208. The honey client system 208 includes control servers 220. The control servers 220 are used to control a plurality of honey miners 222 which are configured to visit web sites and mimic human browser behavior in an attempt to detect malicious code on the

2013206427 20 Jun 2013

websites. The honey miners 222 may be passive honey miners or active honey miners. A passive honey miner is similar to a web crawler as described above. However, unlike the web crawler above which merely visits the website and reports the URL links available from that site, the passive honey miners may be configured to download the page content and return it to the control servers 220 for insertion into the URL database 180. The honey miners 222 may be software modules on a single machine, or alternately, they may be implemented each on a separate computing device.

[0088] In one embodiment, each control server may control 17 passive honey miners 222. The control servers 220 may extract or receive URLs from the URL database 180 which need additional information in order to be fully analyzed or categorized. The control servers 220 provide the URLs to the miners which in turn review the URLs and store the collected data. When a passive miner 222 is finished with a particular URL, it may request another URL from its control server 222. In some embodiments, the miners 222 may be configured to follow links on the URL content so that in addition to visiting URLs specified by the control server 220, the miners may visit content that it linked to those URLs. In some embodiments, the miners 222 may be configured to mine to a specified depth with respect to each original URL. For example, the miners 222 may be configured to mine down through four layers of web content before requesting new URL data from the control server 220.

[0089] In other embodiments, the control servers 220 may be configured to control active honey miners 222. In contrast to the passive honey miners which only visit web sites and store the content presented on the sites, the active honey miners 222 may be configured to visit URLs and run or execute the content identified on the sites. In some embodiments, the active honey miners 222 include actual web browsing software that is configured to visit websites and access content on the websites via the browser software. The control server 220 (or the honey miners themselves 222) may be configured to monitor the characteristics of the honey miners 222 as they execute the content on the websites they visit. In one embodiment, the control server 220 will record the URLs that are visited by the honey miners as a result of executing an application or content on the websites visited. Thus, active honey miners 222 may provide a way to more accurately track system behavior and discover

previously unidentified exploits. Because the active honey miners expose themselves to the dangers of executable content, in some embodiments, the active honey miners 222 may be located within a sandbox environment, which provides a tightly-controlled set of resources for guest programs to run in, in order to protect the other computers from damage that could be inflicted by malicious content. In some embodiments, the sandbox may take the form of a virtual machine emulating an operating system. In other embodiments, the sandbox may take the form of actual systems that are isolated from the network. Anomalous behavior may be detected by tracking in real-time, changes made to the file system on the sandbox machine. In some embodiments, the code executed by the active honey miners 222 may cause the machine on which they are running to become inoperable due to malicious code embedded in the webpage content. In order to address this issue, the control server may control a replacement miner which may step in to complete the work of a honey miner 222 which is damaged during the mining process.

[0090] Referring now to Figure 11, an example of a set of URL-related data that has been collected by the collection system is provided. Although a particular example of collected data is provided, one of skill in the art will appreciate that other data might be collected in addition to the data provided in this example. Included in the collected data is an IP address 230 for the URL. The IP address 230 may be used to identify websites that are hosting multiple domains of questionable content under the same IP address or on the same server. Thus, if a URL having malicious content is identified as coming from a particular IP address, the rest of the data in the URL/content database 180 may be mined for other URLs having the same IP address in order to select them and more carefully analyze them. The collected URL data may also include a URL 232 as indicated by the second column in Figure 11. In instances where the data is collected using a mining process such as the honey client process described above, the URL 232 may often include various pages from the same web domains, as the miners may have been configured to crawl through the links in the websites. The collected data may also include the page content 234 for a particular URL. Because the content of a URL may be in the form of graphics, text, applications and/or other content, in some embodiments, the database storing this URL data may be configured to store the page content as a binary large object (blob) or application objects in the data record. However, as

some web pages contain text exclusively, the page content 234 may be stored as text as well. In some embodiments, the collection routine may be configured to determine whether the URL contains executable content. In these instances, the resultant data set of collected data may include an indication of whether the URL has executable content 236 within its page code. This information may be later used in selecting data from the URL/content database 180 as candidate data for analysis.

[0091] FIG. 12 is a block diagram illustrating the scoring and categorization system 186 from Figure 7. In one embodiment, the scoring and categorization module 186 includes a properties database 320, a processed web page properties database 324, a definitions database 326, a static content classification module 328, a content scoring module 330, and a reputation scoring module 331. In one embodiment, the scoring and categorization system 186 includes an active analysis module 332. The content analysis module 322 receives one or more candidate URLs from the URL database 180 and identifies properties from the properties database 320 that it finds associated with each candidate URL. The values and/or counts of the properties for each URL are stored in the processed web page properties database 324. The static content classification module 328 queries the processed web page properties database 324 based on definitions from the definitions database 326 to associate categories with the candidate URLs. The content scoring module 330 may further associate a score with each URL that can be used to further categorize or to change the categories identified by the static content classification module 328. In one embodiment, the content scoring module 330 may identify candidate URLs for processing by the active analysis module 332. The active analysis module 332 downloads and executes any active content to identify behavior properties associated with the URL. These properties may then be provided to the content scoring module to further categorize the candidate URLs, e.g., change their categories, or add additional categories.

[0092] For example, a URL that is processed by the content analysis module 322 may receive a “malicious” category. The content scoring module 330 may then associate a score, e.g., a low score, with the URL that is indicative of the URL not being malicious. To resolve, the content scoring module 330 may provide the URL as a candidate URL to the active analysis module 332 to identify further properties or a behavior score that can be used

by the content scoring module 330 to determine whether the “malicious” category is appropriate.

[0093] The properties database 320 includes keywords, regular expressions, and other web page properties that can be used to categorize web pages. Properties may also be values associated with the web page such as HTTP request header data or other meta data associated with the web page. For example, properties may includes keywords to be identified in the document such as “<javascript>,” “<object>,” regular expressions such as “data=.\*\.txt” (e.g., the keyword “data=” followed by an arbitrary length string followed by “.txt”), or the content-type of the data from the HTTP header. FIG. 13A is an example of a properties database that includes the property and an additional field identifying the type of property, e.g., a keyword or a regular expression. In the illustrative database, a property ID field is used to provide a unique (within the database) identifier for each property. In other embodiments, other suitable types of keywords may be used.

[0094] In one embodiment, the content analysis module 322 receives candidate URLs from the URL database 180 that have been identified by the collection system 182. The content analysis module receives the content and other data associated (such as the HTTP header) with the URLs and identifies one or more of the properties in the properties database 320 that are associated with the candidate web pages and stores data relating to those properties in the processed web page properties database 324. The content analysis module 322 may receive the content of the candidate web pages from the URL database or it may download the data itself. In one embodiment, the honey client module 208 obtains and stores the content of each candidate web page in the URL database. In another embodiment, the content analysis module 322 downloads the content of the candidate web pages as part of processing the web page for properties.

[0095] In general, the properties database 320 stores the properties and sufficient information to identify the properties associated with a web page. For example, for keyword or regular expression properties, the properties database 320 may store the keyword or regular expression. In contrast, the processed web page properties database 324 may store counts of the keyword or regular expression found to be associated with each web page by the content analysis module 322. For regular expressions, depending on the embodiment, either a count

of matching expressions or the matching expressions themselves, or both may be stored in the processed web page properties database 324. For example, for a particular web page, the processed web page properties database 324 might store the value 3 referring to the number of times that the property “<javascript>” appears in the page, 0 for the number of times the property “<object>” appears, and “data=http://www.example.url/example.txt.” for the regular expression property “data=.\*\.txt.”

[0096] Figure 13B illustrates one embodiment of table in the processed web page properties database 324 in which the example properties of Figure 13A have been processed with respect to several web pages. In the illustrated embodiment, the database includes two tables, one relating URLs to unique (within the database) identifiers and a second relating the URL identifiers with properties associated with that URL. In the illustrated embodiment, the table includes an entry or row for each property of the web content data associated with the URL. In one embodiment, the database also includes numeric values for each property/URL corresponding to the keyword properties to indicate the number of times that the particular property was found in the web page. The database, for example in the URL/property table, may also include the actual expression matching a regular expression property for the URL. In one embodiment, the keyword properties can be searched in the page body and in the header or other metadata. In one embodiment, only the page body is searched. In yet another embodiment, the property may be associated with data, e.g., in the properties database 320, that indicates what data to process in identifying the property in a web page.

[0097] In one embodiment, the static content classification module 328 accesses web page properties database 324 and compares the properties for one or more web pages with definitions from the definitions database 326. When a web page matches a particular definition, the web page is identified with one or more categories associated with the definition. In one embodiment, these categories are stored in the URL database in association with the URL. In one embodiment, each definition is expressed in terms of one or more properties of the web page. In one embodiment, definitions are expressed as first order logical operations relating one or more of the properties. In one embodiment, terms of the definition are comprised of comparisons between web page properties or between properties and values (including constant values). For example, a definition might include an

2013206427 20 Jun 2013

expression such as “property\_1” = “property 2” AND occurrences of property\_3 > 5. In addition to comparisons, terms may include other operations on web page properties such as mathematical, string, or any other suitable computational expression. For example, a simple definition can be “data=,\*\\*.txt” = “data=xyx333.txt”, which matches any web page having as part of its content the string “data=xyx333.txt” (which matches the regular expression property “data=,\*\\*.txt”). More complex definitions may comprise logical operations on the terms. Such logical operations may include AND, OR, NOT, XOR, IF-THEN-ELSE, or regular expression matches on the properties. In one embodiment, the definitions may also include or correspond to database query expressions such as standard SQL database comparison functions and logical operations. In one embodiment, definitions may include executable code such as scripts or references to executable programs or scripts that at least partially determine a classification for a URL. Figure 13C illustrates an exemplary portion of a definitions database 326 according to one embodiment. As used herein, categories can refer to any type of classification. For example, a category may be merely a classification that indicates that further processing or analysis be performed for the URL to identify a category for the URL.

[0098] In one embodiment, the content scoring module 330 further analyzes web pages and assigns a score to the web page associated with one or more categories. In one embodiment, the score may be based on a weighted combination of the number of times that keywords are found in the web page. In one embodiment, the weights are stored in the properties database in association with the corresponding property. In one embodiment, the content scoring module 330 communicates such URLs to the active analysis module 332 for additional analysis.

[0099] In one embodiment, the content scoring module 330 bases the score at least partly on a reputation score generated by the reputation scoring module 331. In one embodiment, the reputation scoring module 331 may be configured to associate a score with a URL based on information about the URL, including URL components such as the URL scheme (e.g., “http:”), the host (e.g., www. uspto.gov) , the path (e.g., “index.html”), the query (e.g., the portion following a “?”), and the fragment (the portion following a “#”). The reputation scoring module 331 may generate the scores based on information about the URL





2013206427 20 Jun 2013

be any set of rules associated with words in a particular language. For example, in one embodiment, a simple word formation rule may identify strings of consonants or vowels that exceed a specified threshold (e.g., four) in length are unlikely to be a word. More sophisticated word formation rules may also be used that generate scores based on unlikely combinations of letters (e.g., xqv in English) in the URL string. For example, in one embodiment, a suitable information theoretic measure of information content such as information entropy may be calculated for one or more component of the URL, the URL, and/or content of the URL. Because strings containing random information tend to have a higher entropy measure, randomly generated data associated with a URL can be identified by scoring the URL based on entropy or by comparing the entropy, or entropy relative to length, of data associated with a URL (URL components, the URL string, and/or content of the URL) to a threshold.

[0100] It has been found that certain combinations of the scoring criteria are particularly useful for identifying active or other target content because, for example, the set of criteria covers a number of different ways that targeted active content might be created to avoid detection. Thus, in one example embodiment, the URL score combines scoring criteria including an entropy score, a score based on historical data associated with the URL, search results associated with the URL, and historical data associated with the IP address of the URL.

[0101] In one embodiment, the reputation scoring module 331 generates scores based on a database of internet addresses and/or domain names. The reputation scoring module 331 may assign scores to entire subnetworks (e.g., all addresses matching 128.2.\*.\* may have a particular score). Such networks or subnetworks help identify a web site as being based in a particular country or with a particular service provider. This has been found to be useful in scoring because certain countries and service providers have been correlated with certain types of web content due to different laws or lax enforcement of laws. The scoring system of networks or subnetworks may be based on the relative number of URLs in particular networks or domains that have a particular category. For example, if 95% of the URLs for a particular network in the URL database 180 are classified as having malicious

active content, new URLs may be given a score indicative of the likelihood that other URLs referencing servers in the same network are also likely to have such targeted content.

[0102] In an embodiment, the reputation scoring module 331 generates an indicator of reputation such as a reputation based on information about the registrar of the site (e.g., the domain name of a URL host). Such registrar information may include, for example, the identity of the registrar, the registrant (including address and contact information of the registrant), when the registrar record was created, when the registrar record was last updated, when the registrar record expires, and any other registrar data including data provided by the WHOIS protocol (e.g., Internet Engineering Task Force (IETF) RFC-3912).

[0103] The reputation scoring module 331 may include a database of changes in registrar data of at least a portion of the URLs in the URL database 180. The frequency or recentness of changes to registrar data associated with a URL may be used to at least partly to generate the reputation score. The reputation score for a URL may be generated at least partly by comparing at least part of the registrar data associated with the URL with registrar data of previously categorized URLs.

[0104] Hosts of targeted content may attempt to confuse or hide their content from filters by using a multiplicity of host and domain names and by frequently changing IP addresses associated with domains. The reputation scoring module 331 may generate reputation indicator data or scores based on a reputation of the name server which is common to the multiple hosts and domains associated with the name server. For example, the reputation scoring module 331 may include a database of nameservers (servers that provide domain name system (DNS) services to translate Internet host names to IP addresses). Generally, particular servers provide DNS services for a particular domain. Thus, if the nameserver for a URL host is the nameserver for other hosts that have previously been categorized or identified with targeted content, the reputation scoring module 331 may utilize this information when generating a reputation score for the uncategorized URL. For example, if the nameserver is associated with targeted content, the reputation score of the uncategorized URL may be low. The reputation scoring module 331 may also maintain a

database of hosts to IP addresses and utilize the database to generate a score based on the frequency with which the IP address changes for a particular host or domain.

[0105] In one embodiment, URLs with scores above a threshold are identified with a category, e.g., malicious, regardless of, or in addition to, the category identified by content analysis of the web page. In one embodiment, multiple scores associated with different categories are assigned to each URL, and the categories corresponding to each score above a given threshold are identified with the URL. In one embodiment, multiple thresholds are employed. For example, URLs having scores above one threshold value automatically are classified based on the score. In one embodiment, URLs having scores that are below the first threshold but above a second threshold are communicated to a human analyst for classification.

[0106] One embodiment may include a scoring and categorization system such that illustrated in U.S. Patent No. 6,606,659, entitled "SYSTEM AND METHOD FOR CONTROLLING ACCESS TO INTERNET SITES," which document is incorporated by reference in its entirety.

[0107] In one embodiment, the active analysis module 332 executes active content of a web page to identify its behavior properties. These properties may then be used to score and classify the web page. In one embodiment, one or more of the static content classification module 328, the reputation scoring module 331, and the content scoring module 330 identifies URLs for processing by the active analysis module 332. After receiving candidate URLs, the active analysis module 332 may provide a behavioral score or data associated with one or more behavior properties (e.g., a property such as "writes to registry") to the content scoring module for further categorization.

[0108] FIG. 14 is a block diagram illustrating one embodiment of the training module 184 from Figure 7. In one embodiment, the training module includes an analysis tasking module 352 that identifies web pages or URLs having content, such as active content, for which additional categories are desired. In one embodiment, the collection module 190 identifies URLs having active content. In another embodiment, an external source, such as security researchers, identify particular URLs having active content that has been identified with one or more categories, e.g., keyloggers, viruses, malicious content, worms, etc. In one

2013206427 20 Jun 2013

embodiment, these may be stored in the URL database 180. In one embodiment, the tasking module 352 maintains a database of such URLs (not shown). In one embodiment, the tasking module 352 database maintains a priority for these URLs and presents them to an analyst based on the priority.

[0109] A property identification module 354 identifies properties of the web page and definitions based on those properties that categorize the web page. In one embodiment, the properties identification module 354 provides an interface for a human analyst to apply particular rules or definitions to a URL using the scoring and classification system 186. In addition, in one embodiment, the property identification module 354 may provide an interface for the analyst to identify the URL as a candidate for the active analysis module 332 of Figure 10 to perform behavioral analysis of the URL to receive additional data for classifying the URL back from the active analysis module 332. The property identification module 354 may then provide this data to the analyst. In one embodiment, the analyst analyzes URL data from the scoring and classification system 186, including the active analysis module 332, to help identify properties and definitions that properly classify the URL and, where possible, other URLs that refer to similarly classified content. In one embodiment, property identification module 354 provides these newly identified properties and definitions to a database update module 356 that stores the new definitions and properties to the properties database 320 and the definitions database 326.

[0110] FIG. 15 is a block diagram illustrating one embodiment of the active analysis module 332 from Figure 12. In one embodiment, the active analysis module 332 includes a sandbox module 370 in which URLs are downloaded and any active content executed as would occur on a typical workstation 116. The sandbox module 370 transparently monitors the state of the computer to identify behavior of the web content affecting, for example, one or more of spawned processes, network access, processor usage, memory usage, use of system resources, file system access or modification, and registry access or modification.

[0111] A behavioral analysis module 372 compares the monitored actions from the sandbox module with a list, a database, or rules that characterize the monitored actions. In one embodiment, these characterizations define properties of the URL that are

subsequently analyzed by the static content classification module 328 of Figure 12. In another embodiment, an active scoring classification module 374 may use scores associated with behavioral properties to determine a score for the URL. In one embodiment, the score is a weighted score of these properties. This score may be used to classify the URL or be communicated to the content scoring module for classification. In another embodiment, rules or definitions, such as those from the definitions database 326 are applied to the behavioral properties of the URL (and, in one embodiment, the processed web page properties 324) to identify one or more categories associated with the URL. In one embodiment, the score of a URL may be at least partly based on identified categories of other URL references within the content of the URL. For example, if the site is unclassified but all the identified categories for the reference (e.g., using an HTML HREF element) are malicious, then the URL may be given a score indicative of the malicious content.

#### Description of Methods of Use and Operation

[0112] Depending on the embodiment, the acts or events of the methods described herein can be performed in different sequences, can be merged, or can be left out all together (e.g., not all acts or events are necessary for the practice of the method), unless the text specifically and clearly states otherwise. In addition, the methods described herein can include additional acts or events unless the text specifically and clearly states otherwise. Moreover, unless clearly stated otherwise, acts or events may be performed concurrently, e.g., through interrupt processing or multiple processors, rather than sequentially.

[0113] As discussed above in connection with Figure 3, in some embodiments, the gateway server module 120 may be configured to control access to certain URLs based on data stored in the categorized URL database 146. Figure 16 is a flowchart describing an embodiment in which the gateway server module handles a request from a workstation 116.

[0114] At block 1200, the workstation 116 requests a URL from the Internet 112. This request is intercepted at the Internet gateway and forwarded to the gateway server module 120 at block 1202. At block 1204, the categorized URL database 146 is queried to determine if the requested URL is stored in the database 146. If the requested URL is found as a record in the database, the process moves on to block 1206, where it analyzes the URL record to determine whether the category of the URL is one that should be blocked for the

workstation user. If the category is blocked, the process skips to block 1212 and the request is blocked. If the category is not blocked, however, the request is allowed at block 1208.

[0115] If the requested URL is not found as a record in the categorized URL database 146 at block 1204, the system proceeds to block 1210. At block 1210, the system determines how to handle the uncategorized content. In some embodiments, the system may utilize the policy module 142 to make this determination. If the gateway server module 120 is configured to block requests for uncategorized content, the process moves to block 1212, and the request is blocked. If, on the other hand, the module is configured to allow these types of uncategorized requests, the process moves to block 1208, where the request is allowed to proceed to the Internet 112.

[0116] In some embodiments, the request of URL data may result in new records being added to the logging database 144. These records may be later transferred to the database management module 114 for further analysis. Referring now to Figure 17, another flowchart describing a process by which the gateway server module may handle a URL request is provided. At block 1300, the gateway server module 120 receives a request for a URL. As noted above, this request may come from a workstation 116. At block 1302, the URL is then compared against the categorized URL database 146, and the system determines at block 1304 whether the requested URL is in the categorized URL database.

[0117] If the URL is already in the categorized URL database 146, the process skips to block 1308. If the requested URL is not found in the categorized URL database 146, however, the process moves to block 1306 where the URL is inserted into the uncategorized URL database 147. In some embodiments, the logging database 144 and the uncategorized URL 147 database may be the same database. After inserting the URL into the database, the method proceeds to block 1308. At block 1308, the policy database is checked for instructions on how to handle the received URL. Once the policy module 142 has been checked, the logging database 144 is updated to record that the URL has been requested at block 1310. If the workstation 116 is permitted to access the URL by the policy database, the process moves to block 1314 and the URL request is sent to the Internet 112. If, however, the policy database does not allow the request, the process skips to block 1316 and the request is blocked.

[0118] In some embodiments, the gateway server module 120 may perform collection activities to lessen the burden on the collecting system 182 of the database management module 114. Figure 18 provides an example of a system in which the gateway server collection module 140 is used to collect data about an uncategorized URL. At block 1400, the gateway server module receives a request for a URL. Next, at block 1402, the requested URL is compared against the categorized URL database. If the system determines that the requested URL is in the URL database at block 1404, the process moves to block 1410, where the request is either forwarded to the Internet 112 or blocked depending on how the URL is categorized.

[0119] If the requested URL is not in the categorized URL database 146, the process moves to block 1406 where the URL is sent to the gateway server collection module 140. Next, at block 1408, the collection module 140 collects URL data about the requested URL. In some embodiments, this data may be stored in the uncategorized URL database 147. Alternatively, this data may simply be forwarded to the database management module 114 via the Internet 112. Once the data has been collected and stored, the process moves to block 1410 where the URL request is either allowed or blocked based on the policies indicated in the policy module 142.

[0120] As discussed previously, uncategorized URL data may be sent from the gateway server module 120 to the database management module 114 for further analysis so that the URL may be categorized and added to the categorized URL database 146. However, because the volume of uncategorized data is so large at times, it may not be possible to categorize all of the received data without compromising accuracy or speed. As a result, in some instances, it may be desirable to identify candidate URLs within the uncategorized data that are most likely to present a threat to workstations 116 and networks 110.

[0121] Figure 19 provides an example of a method for identifying candidate URLs for further analysis. The method starts with a URL being received into the collection system 182 of the database module 114. At block 1502, the URL or application is preprocessed to determine whether it carries a known malicious data element or data signature. Next, at block 1504, if the system determines that the URL includes a known malicious element, the process skips to block 1514 where the URL is tagged as a candidate

2013206427 20 Jun 2013

URL and sent to the scoring/classification system 186 for further analysis. If the initial analysis of the URL in block 1504 does not reveal a malicious element, the process moves to block 1506, where the URL is added to a database of potential candidate URLs. Next, at block 1508, the data mining module 192 is configured to select URLs from sources 194 (of which the database of potential candidate URLs is one) based on preconfigured conditions such as attack strings, virus signatures, and the like. The data set including all of the data sources 194 is then sent to the data mining module 192 at block 1510, where each URL is analyzed by the data mining module 192 at block 1512. If the URL satisfies the defined preconfigured conditions, the process moves to block 1514 where the URL is tagged as a candidate URL and sent on to the scoring/classification system 186 for additional analysis. If, however, the URL does not meet the conditions specified for converting it to a candidate URL, the method proceeds to block 1516 and the URL is not tagged as a candidate. Although this embodiment is described in the context of URL candidate classification, one of skill in the art will readily appreciate that applications may be similarly analyzed and tagged as candidates using the process described above.

[0122] As discussed above, one of the challenges to collecting and analyzing Internet data to determine whether it includes harmful active content is the sheer volume of data that must be collected and analyzed. In yet another embodiment, the data mining module 192 may be used to address these issues by collecting large volumes of relevant data to utilize system resources effectively and efficiently. Referring now to Figure 20, a more detailed block diagram of the data mining system 192 is provided. The data mining system 192 may take the form of a software module that runs a plurality of asynchronous processes to achieve maximum efficiency and output. The data mining system 192 may include a plug-in module 242 which receives configuration parameters which provide instruction on how inputted data should be handled. In one embodiment, the instructions received by the plug-in module may take the form of an HTTP protocol plug-in that provide parameters for the data mining system 192 to receive URL data and analyze and supplement the data based on various HTTP-related instructions implemented by the data mining system on the URL data. In another embodiment, the plug-in may be geared toward mining some other protocol such as FTP, NNTP, or some other data form.



[0123] The data mining system 192, which may also be used to implement passive honey clients, also include a pool 246 of dispatchers 248. The dispatchers 248 are individual asynchronous processing entities that receive task assignments based on the data input (for analysis) into the data mining system and the configuration data received by the plug-in module 242. The pool 246 is a collection of the dispatchers that is controlled by a driver 244. The driver 244 is a managing mechanism for the pool. The driver 244 may be configured to monitor the activity of the dispatchers 248 in the pool 246 to determine when to send additional data into the pool 246 for mining and analysis. In one embodiment, the driver may be configured to send new data units into the pool 246 whenever any dispatchers 248 are idle. In one embodiment, the driver 244 may be utilized as a control server for managing honeyclient miners 222 as described above in connection with Figure 10. The pool 246 may deliver the data unit to the idle dispatcher 248. The dispatcher 248 reads the plug-in configuration and performs actions in accordance with plug-in module 242.

[0124] In one embodiment, the plug-in module 242 may receive an HTTP plug-in. The HTTP plug-in may be configured to receive input data in the form of URL strings about which the data mining system 192 will obtain additional information such as the page content for the URL, HTTP messages returned by the URL when accessed (such as “4xx - file not found” or “5xx – server error”). The plug-in may further specify a webcrawling mode in which the dispatches, in addition to collecting page content, also add URL links within the URL content to the URL data set to be analyzed.

[0125] FIG. 21 is a flowchart illustrating one embodiment of a method 2000 of categorizing URLs within the database management module 114. The method 2000 begins at a block 2002 in which properties are developed that can be used to categorize web pages. In one embodiment, the training module 184 is used to develop the properties in the properties database 320. In one embodiment, developing the properties includes developing definitions, e.g., expressions relating one or more properties, and storing the definitions in the definitions database 326. Next at a block 2004, web pages are identified for content analysis. In one embodiment, the collections module 190 identifies web pages for content analysis. In one embodiment, web pages having properties or other indicia of active content are identified for content analysis.

2013206427 20 Jun 2013

[0126] Moving to a block 2006, the content analysis module 322 identifies one or more properties associated with each of the identified web pages. Functions of block 2006 are described in more detail hereafter with reference to Figure 22. Proceeding to a block 2010, the static content classification module 328 identifies web pages with one or more categories based at least partly on properties. In one embodiment, the static content classification module 328 compares definitions from the definitions database 326 with the properties of each web page to identify its properties. In one embodiment, the categories include those indicative of whether the web page is associated with active content. In one embodiment, the categories include those indicative of types of active content, e.g., malicious, phishing sites, keyloggers, viruses, worms, etc., associated with or referenced by the web page. In one embodiment, the active content is included in the body of the web page. In one embodiment, the active content is referenced in a link or ActiveX object element of the web page. In one embodiment, active content includes interactive “phishing” sites that include content tending to mislead users into providing credentials or other sensitive, private, or personal information. In one embodiment, the scoring module 330 further scores and classifies the web pages. Moving to a block 2012, the categories associated with the web pages are stored in the URL database. In one embodiment, the upload download module 178 of Figure 7 distributes the new URL categories to one or more gateway server modules 120 or workstations 116 (both of Figure 1). In one embodiment, one or more blocks of the method 2000, e.g., blocks 2006-2012, may be performed either continuously as new URLs are received by the collections module 190. In one embodiment, one or more blocks of the method 2000, e.g., blocks 2006-2012, may be performed periodically.

[0127] FIG. 22 is a flowchart illustrating one embodiment of a method of performing the function of the block 2006 of Figure 21. The method begins at a block 2020 in which the content analysis module 322 receives a list of web page URLs in the URL database 180. In one embodiment, the collection module 190 provides the list of candidate URLs. Next at a block 2022, for each URL, the content analysis module 322 receives downloaded web page content. In one embodiment, the collection module 190 downloads the content and stores it in the URL database 180 from which the content analysis module 322 accesses the content. In another embodiment, the content analysis module 322

downloads and processes the content. Moving to a block 2024, the content analysis module 322 accesses properties from the properties database 320. Next at a block 2026, the content analysis module 322 identifies properties that are associated with each of the web pages based at least partly on the content of each of the web pages. In one embodiment, the content analysis module 322 scans the content to identify string, keyword, and regular expression properties from the properties database 320. In one embodiment, the content analysis module 322 may also decode content prior to, and/or after, scanning for properties. For example, the content analysis module 322 may decode web content such as URL-encoded portions of URLs or hex-coded web addresses prior to scanning to help prevent keywords from being hidden by encoding or partially encoding the keywords. Proceeding to a block 2028, the content analysis module 322 stores the identified properties associated with each web page in the processed web page properties database 324.

[0128] FIG. 23 is a flowchart illustrating one embodiment of a method of performing the function of the block 2010 of Figure 21. The method begins at a block 2042 in which the static content classification module 328 accesses definitions indicative of web page categories from the definitions database 326. Next at a block 2044, for each definition, the static content classification module 328 identifies one or more queries associated with each definition against the processed web page properties database 324. In one embodiment, the queries comprises SQL queries.

[0129] Moving to a block 2046, the static content classification module 328 compares the properties of the URLs in the web page properties database to the query to identify URLs matching the query. In one embodiment, the static content classification module 328 performs the comparison by executing the one or more identified database queries against the processed web page properties database 324. Next at a block 2050, the static content classification module 328 compares any identified URLs with the definition to identify any of the identified URLs that match the definition. In one embodiment, this comparison includes comparing the results of the database query using additional executable instructions, such as a Perl script, to identify matching URLs. Proceeding to a block 2052, the static content classification module 328 categorizes the identified URLs based on the definition. In one embodiment, each definition is associated with a single category. In

2013206427 20 Jun 2013

another embodiment, each definition is associated with several categories that are each identified with the URL. In yet another embodiment, the definition may include logical expressions that identify one or more categories to identify with the URL. For example, an if-then-else expression may identify different categories depending on the result of the if expression. In one embodiment, the content scoring module further scores the URL. Based on the score, the same, different, or additional categories may be identified with the URL. Next at a block 2054, the static content classification module 328 stores the categories of each URL to a categorized web page database. In one embodiment, the URL database 180 includes the categorized web page database.

[0130] FIG. 24 is a flowchart illustrating one embodiment of a method of performing the function of the block 2002 of Figure 21 as part of identifying the properties used in categorizing URLs in the methods of Figures 22 and 23. The method begins at a block 2062 in which the analysis tasking module 352 of Figure 14 receives active content data or URLs associated with active content. Next at a block 2064, property identification module 254 identifies properties that distinguish the target URLs related to the active content data from other URLs and identifies one or more categories associated with the target URLs. In one embodiment, the scoring and classification system 186 is used to help identify these properties. In addition, definitions comprising one or more of the properties may be identified that distinguish the target URLs that are associated with a particular category from other URLs that should not be associated with that category. Moving to a block 2068, the database update module 356 stores the properties, definitions, and categories in the properties database 320 and the definitions database 326. These updated properties and definitions are thus made available for processing URLs using, for example, the method illustrated in Figure 21.

[0131] FIG. 25 is a flowchart illustrating one embodiment of a method 3000 of controlling access to web content based on the components of a requested URL. The method 3000 begins at a block 3010 in which, for example, the URL analysis module 149 of the gateway server module 120 of Figure 1 receives a request for a URL from a workstation 116. Next at a block 3014, a reputation scoring module generates a reputation score or other reputation indicator of targeted content associated with the URL. The reputation scoring

module may be located locally at the gateway server module 120 or remote from the gateway server module 120. For example, the reputation scoring module 331 may be part of the database management module 114.

[0132] Methods of generating reputation scores are discussed above with reference to the URL analysis module 149 and the reputation scoring module 331. It is to be recognized that, depending on the embodiment, reputation scoring may be performed either as a sole means of allowing access to requested URLs or in combination with URL policies and/or URL categories. Moving to a block 3010, the gateway server module 120 determines whether to allow access to the URL based at least partly on the reputation score.

[0133] Alternatively, or additionally, the reputation scoring module 331 may provide the reputation score to the content scoring module 330, which may determine a category of the requested URL at least partly based on the reputation score. The gateway server module 120 may rely upon the determined category in combination with the score associated with the URL when determining whether to allow the user access to the website associated with the requested URL.

[0134] As used herein, “database” refers to any collection of stored data stored on a medium accessible by a computer. For example, a database may refer to flat data files or to a structured data file. Moreover, it is to be recognized that the various illustrative databases described in connection with the embodiments disclosed herein may be implemented as databases that combine aspects of the various illustrative databases or the illustrative databases may be divided into multiple databases. For example, one or more of the various illustrative databases may be embodied as tables in one or more relational databases. Embodiments may be implemented in relational databases, including SQL databases such as MySQL, object oriented databases, object-relational databases, flat files, or any other suitable data storage system.

[0135] Those of skill will recognize that the various illustrative logical blocks, modules, circuits, and algorithm steps described in connection with the embodiments disclosed herein may be implemented as electronic hardware, computer software, or combinations of both. To clearly illustrate this interchangeability of hardware and software, various illustrative components, blocks, modules, circuits, and steps have been described

2013206427 20 Jun 2013

above generally in terms of their functionality. Whether such functionality is implemented as hardware or software depends upon the particular application and design constraints imposed on the overall system. Skilled artisans may implement the described functionality in varying ways for each particular application, but such implementation decisions should not be interpreted as causing a departure from the scope of the present invention.

[0136] The various illustrative logical blocks, modules, and circuits described in connection with the embodiments disclosed herein may be implemented or performed with a general purpose processor, a digital signal processor (DSP), an application specific integrated circuit (ASIC), a field programmable gate array (FPGA) or other programmable logic device, discrete gate or transistor logic, discrete hardware components, or any combination thereof designed to perform the functions described herein. A general purpose processor may be a microprocessor, but in the alternative, the processor may be any conventional processor, controller, microcontroller, or state machine. A processor may also be implemented as a combination of computing devices, e.g., a combination of a DSP and a microprocessor, a plurality of microprocessors, one or more microprocessors in conjunction with a DSP core, or any other such configuration.

[0137] The steps of a method or algorithm described in connection with the embodiments disclosed herein may be embodied directly in hardware, in a software module executed by a processor, or in a combination of the two. A software module may reside in RAM memory, flash memory, ROM memory, EPROM memory, EEPROM memory, registers, hard disk, a removable disk, a CD-ROM, or any other form of storage medium known in the art. An exemplary storage medium is coupled to the processor such the processor can read information from, and write information to, the storage medium. In the alternative, the storage medium may be integral to the processor. The processor and the storage medium may reside in an ASIC. The ASIC may reside in a user terminal. In the alternative, the processor and the storage medium may reside as discrete components in a user terminal.

[0138] In view of the above, one will appreciate that embodiments of the invention overcome many of the longstanding problems in the art by providing an efficient means of processing the large numbers of URLs that are available on the Internet to identify

2013206427 20 Jun 2013

categories for URLs, particularly those that have active content. URLs having many types of active content may be difficult even for a human analyst to categorize because the relevant properties may be buried in executable code, including scripts, or in parameters to ActiveX components. The use of properties and definitions that can be efficiently processed allows ActiveX content to be effectively identified by an automatic process. Furthermore, by storing the properties of web pages in a database for later querying, large numbers of URLs can immediately be categorized based on these stored properties when a new definition of active content is identified.

[0139] While the above detailed description has shown, described, and pointed out novel features of the invention as applied to various embodiments, it will be understood that various omissions, substitutions, and changes in the form and details of the device or process illustrated may be made by those skilled in the art without departing from the spirit of the invention. As will be recognized, the present invention may be embodied within a form that does not provide all of the features and benefits set forth herein, as some features may be used or practiced separately from others. The scope of the invention is indicated by the appended claims rather than by the foregoing description. All changes which come within the meaning and range of equivalency of the claims are to be embraced within their scope.

WHAT IS CLAIMED IS:

1. A method of controlling access to web content comprising:  
receiving a request for at least one uniform resource locator (URL);  
generating an indicator of active content associated with the URL, wherein the indicator is based on data associated with at least one component of the URL; and  
determining whether to allow the request based at least partly on the indicator.
2. The method of Claim 1, wherein the data associated with at least one component of the URL comprises at least one of an indicator of entropy, a search result, data indicative of the history of the URL, and data indicative of the history of a network address associated with the URL.
3. The method of Claim 1, wherein the at least one component of the URL comprises one of a scheme of the URL, a host of the URL, a path of the URL, or a query fragment of the URL.
4. The method of Claim 1 further comprising comparing at least a portion of the URL to at least one word from a dictionary.
5. The method of Claim 1 further comprising generating a score by applying at least one word formation rule to at least a portion of the URL.
6. The method of Claim 5 further comprising identifying a sequence of consonants in at least a URL, wherein the sequence of consonants exceeds a specified length.
7. The method of Claim 1 further comprising:  
identifying a category associated with the URL, wherein determining whether to allow the request is based at least partly on the identified category.
8. The method of Claim 1 further comprising identifying a policy associated with the URL, wherein the determining whether to allow the request is based at least partly on the policy.
9. The method of Claim 8 further comprising determining whether the URL is in a database of categorized URLs.
10. The method of Claim 9 further comprising identifying the at least one policy based on the absence of the URL from the database.



2013206427 20 Jun 2013

11. The method of Claim 1, wherein the indicator of active content comprises a score.
12. A system for controlling access to web content comprising:
  - a gateway server module configured to receive a request for at least one uniform resource locator (URL);
  - a URL analysis module configured to generate an indicator of active content associated with the URL based on data associated with at least one component of the URL;
  - a policy module configured to identify a policy associated with the URL; and
  - a content filtering module configured to determine whether to allow the request based at least partly on the indicator and the policy.
13. The system of Claim 12, wherein the data associated with at least one component of the URL comprises at least one of an indicator of entropy, a search result, data indicative of the history of said URL, and data indicative of the history of a network address associated with the URL.
14. The system of Claim 12, wherein the at least one component comprises one of a scheme of the URL, a host of the URL, a path of the URL, or a query fragment of the URL.
15. The system of Claim 12, wherein the URL analysis module is configured to compare at least a portion of the URL to at least one word from a dictionary.
16. The system of Claim 12, wherein the URL analysis module is configured to generate a score by applying at least one word formation rule to at least a portion of the URL.
17. The system of Claim 16, wherein applying the at least one word formation rule comprises identifying a sequence of consonants in at least one URL, wherein the sequence of consonants exceeds a specified length.
18. The system of Claim 12, further comprising:
  - a categorized URL database configured to identify a category associated with the URL, wherein determining whether to allow the request is based at least partly on the identified category.

2013206427 20 Jun 2013

19. The system of Claim 12, wherein the content filtering module is configured to determine whether to allow the request based at least partly on the policy.

20. The system of Claim 19, wherein the gateway server module is configured to determine whether the URL is in a database of categorized URLs.

21. The system of Claim 20, wherein the policy module is configured to identify the at least one policy based on the absence of the URL from the database.

22. The system of Claim 12, wherein the indicator of active content comprises a score.

23. A system for controlling access to web content, the system comprising:  
means for receiving a request for at least one uniform resource locator (URL);  
means for generating an indicator of active content associated with the URL,  
wherein said indicator is based on data associated with at least one component of the URL;  
means for identifying a policy associated with the URL; and  
means for determining whether to allow said request based at least partly on the at least indicator and the policy.

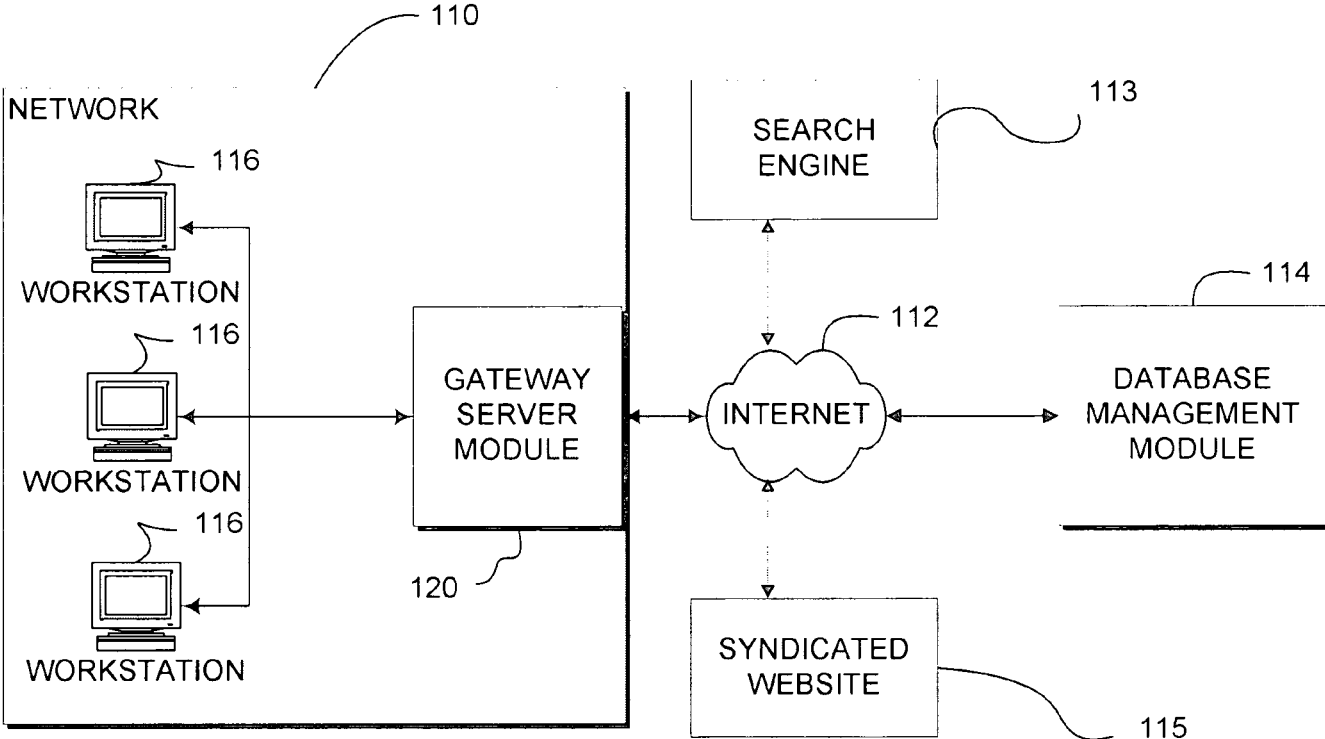

FIG. 1

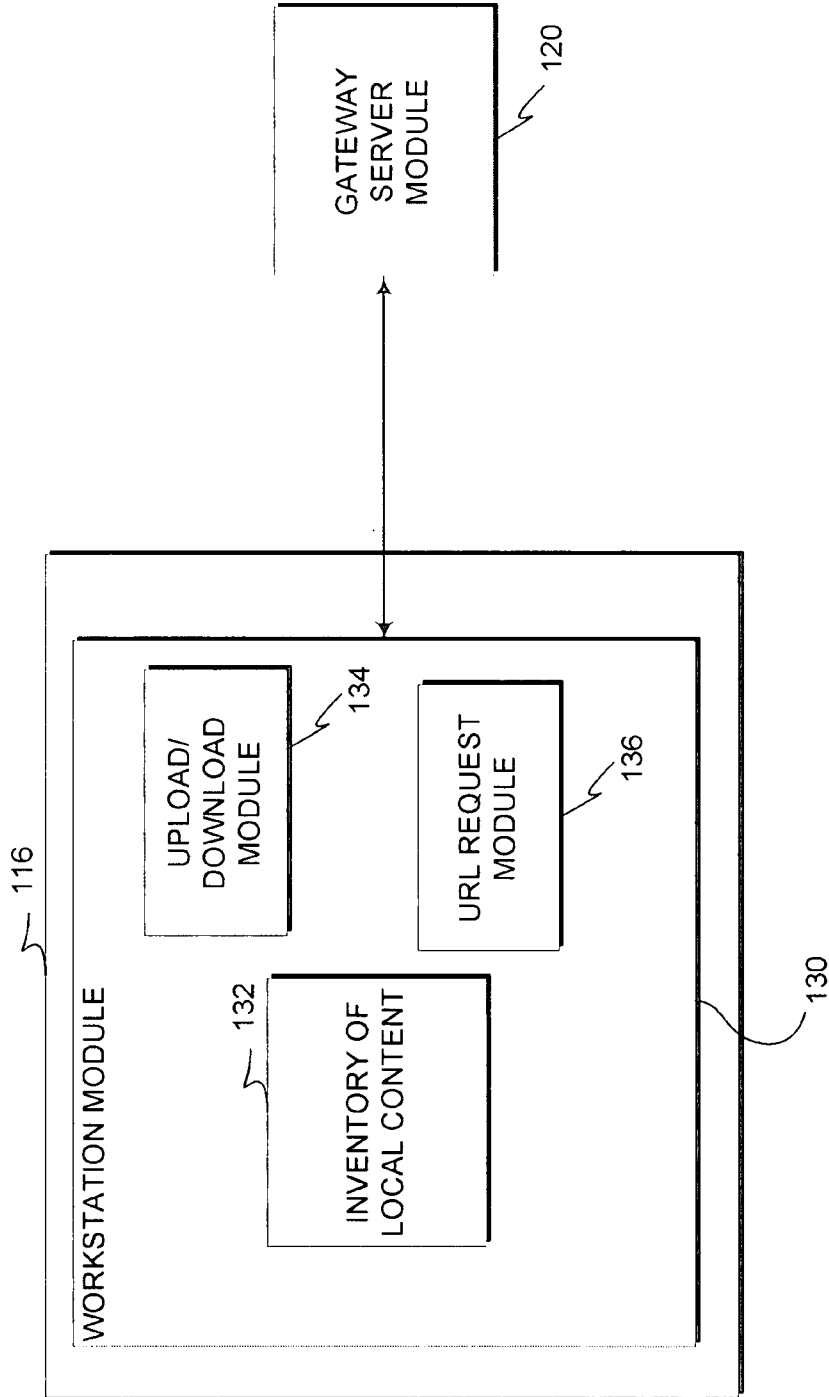

FIG. 2

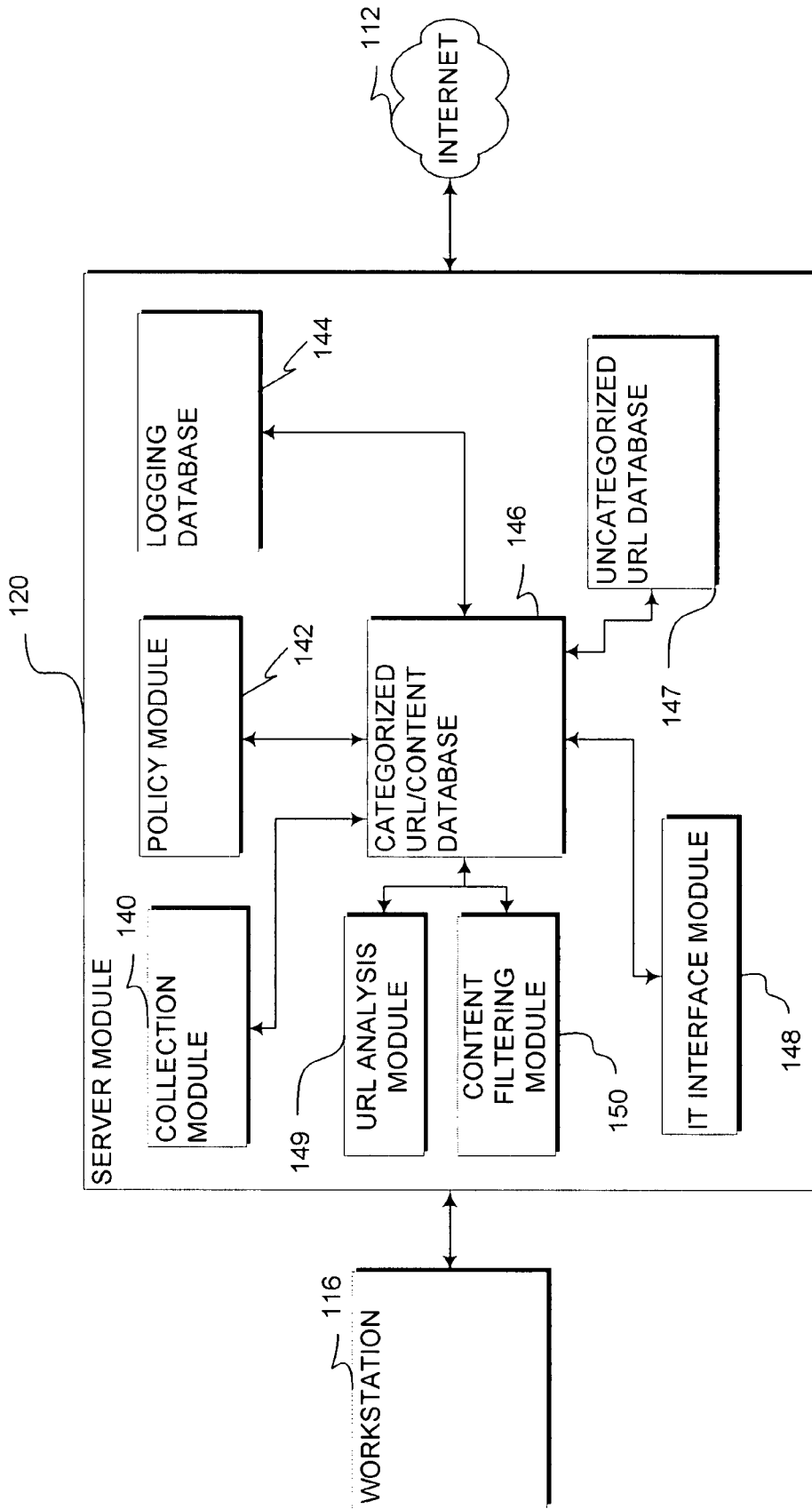

FIG. 3

Logging Database

No. Requests	URL	JavaScript?	ActiveX?
9000	<a href="http://www.google.com">www.google.com</a>	Yes	Yes
32	<a href="http://www.amazon.com/specialoftheday">www.amazon.com/specialoftheday</a>	No	Yes
2	<a href="http://www.sportsworld.com">www.sportsworld.com</a>	Yes	No
1	<a href="http://www.aasdfghd.com">www.aasdfghd.com</a>	No	No

144

152

154

155

156

FIG. 4

URL Access Policy Database

User	Category	Always block?	Allowed Times
asmith	Malicious	Yes	
bnguyen	Gambling		6pm - 8 am
clee	Spyware	Yes	
	Politics		6pm - 8 am

158

160

162

164

166

FIG. 5

146

<i>Categorized URLs</i>	
URL	Category
http://example1.com/ abc	Malicious
http://example2.biz/a bc	Gambling
http://example4.com/ abc	Spyware

172

174

**FIG. 6A**

147

<u>Uncategorized URLs</u>
URL
http://example4.com/abc
http://example6.biz/abc
http://example1.com/abc

**FIG. 6B**

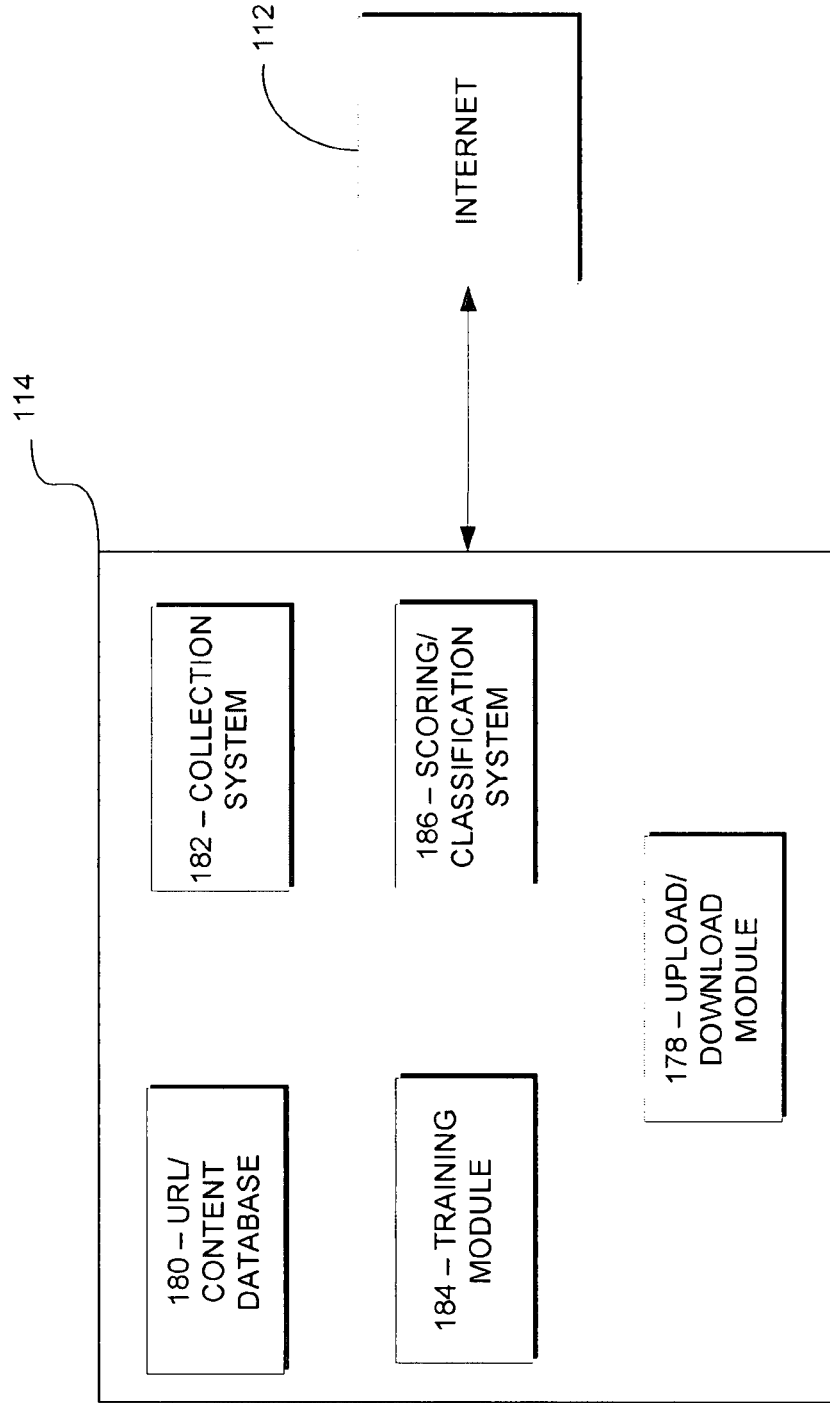

FIG. 7



2013206427 20 Jun 2013

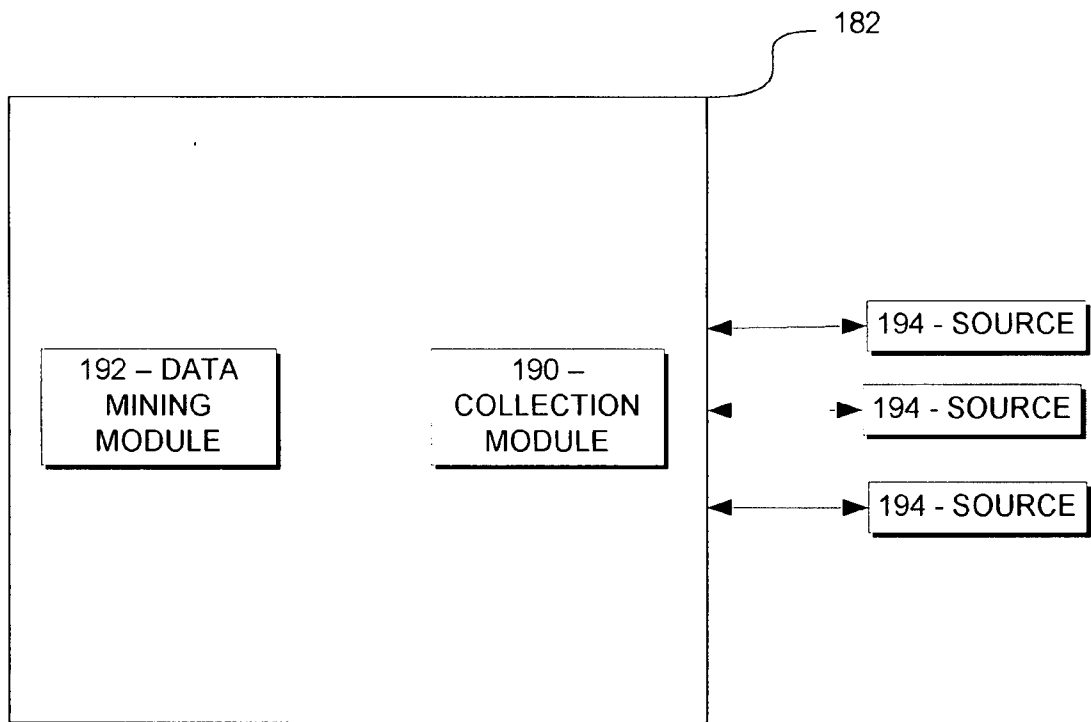

FIG. 8

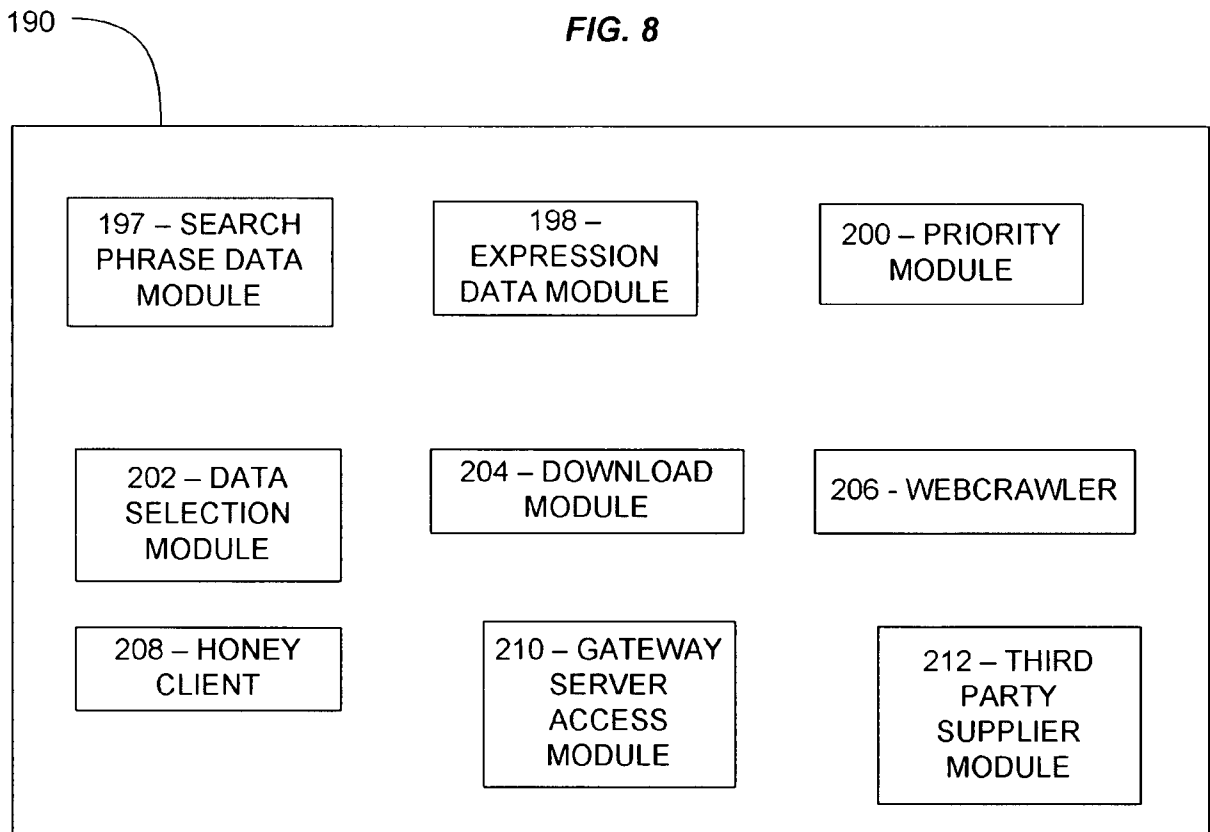

FIG. 9

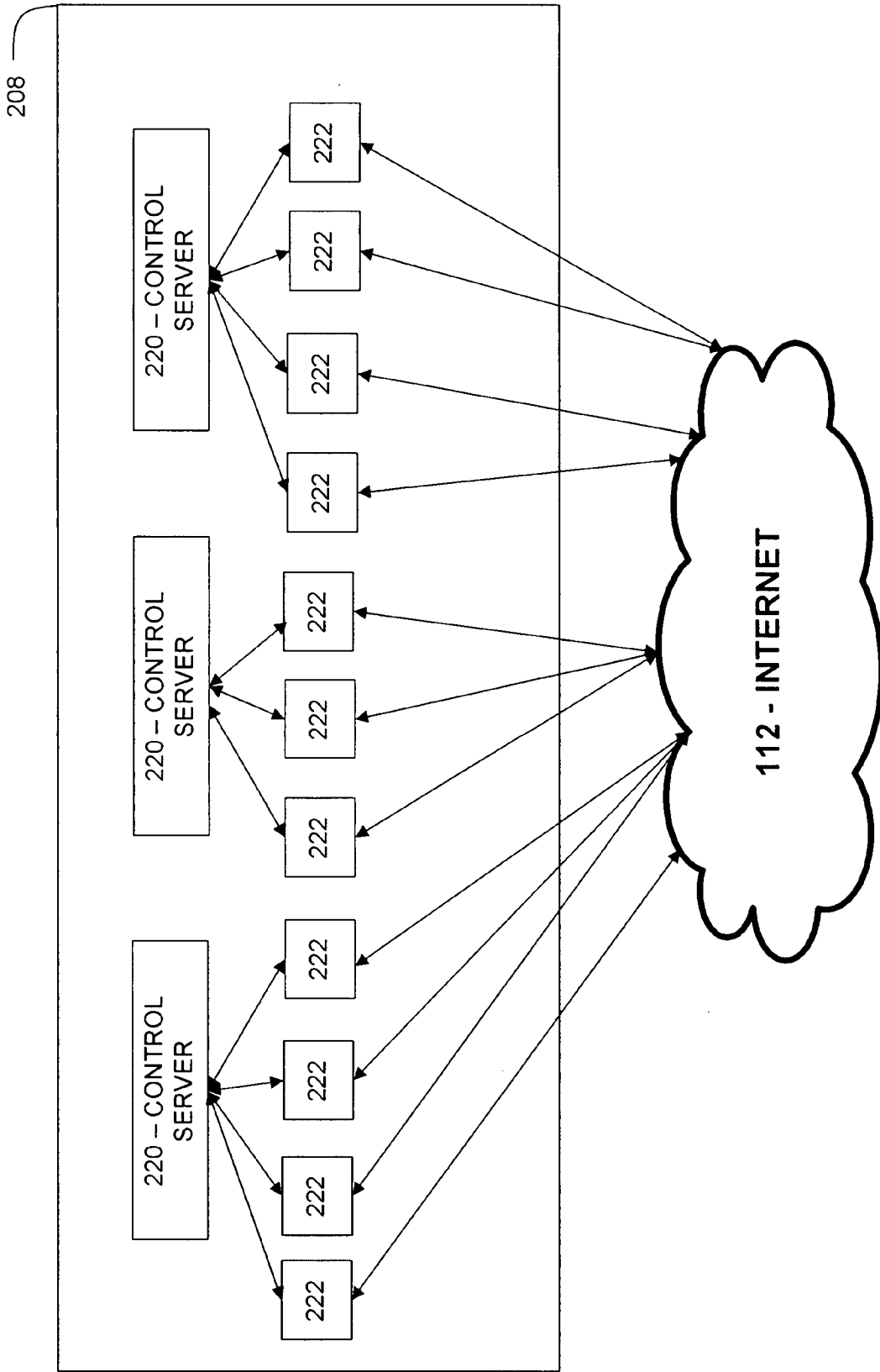

FIG. 10

URL DATA COLLECTED BY COLLECTION SYSTEM

IP ADDRESS	URL	PAGE CONTENT	ACTIVE CONTENT?
134.34.54.158	<u>www.gouggle.com</u>	BLOB	Yes
152.68.94.129	<u>www.amazon.com/specialoftheday</u>	BLOB	Yes
10.42.228.233	<u>www.sportsworld.com</u>	BLOB	No
152.36.242.21	<u>www.aasdfghd.com</u>	TEXT	No
134.34.54.158	<u>www.gouggle.com/page2.html</u>	BLOB	Yes

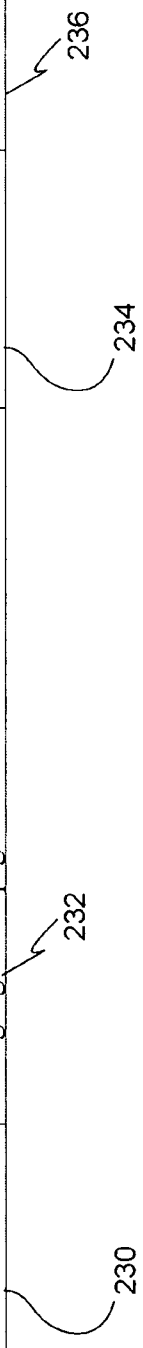

FIG. 11

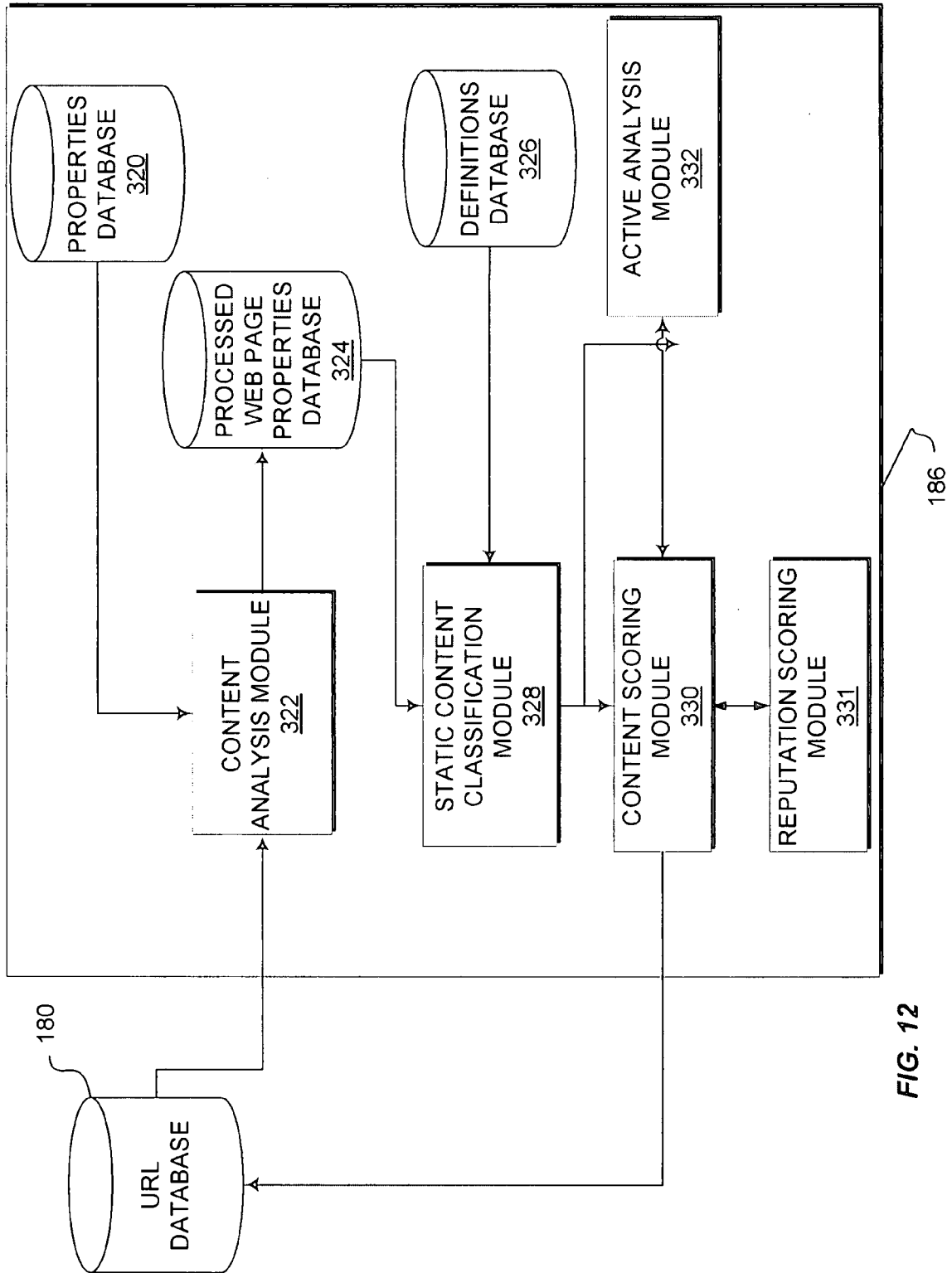

FIG. 12

FIG. 13A

Properties Database

Property_id	Property	Type
1	<javascript>	Keyword
2	<object>	Keyword
3	data=*\txt	Regular Expression
4	Content-Type	HTTP data

FIG. 13B

Processed Web Page Properties Database

url_id	url	Property_id
1	http://www.a.com	1
2	http://www.b.com	2
3	http://www.c.com	3
4	http://www.d.com	4

FIG. 13C

Definitions Database

Expression	Category
Content-Type = HTML and "<javascript>" > 2	Malicious
<object> = 6 and URL matches "a.com"	Gambling
"data=*\txt" = "data=xyx333.txt"	Spyware

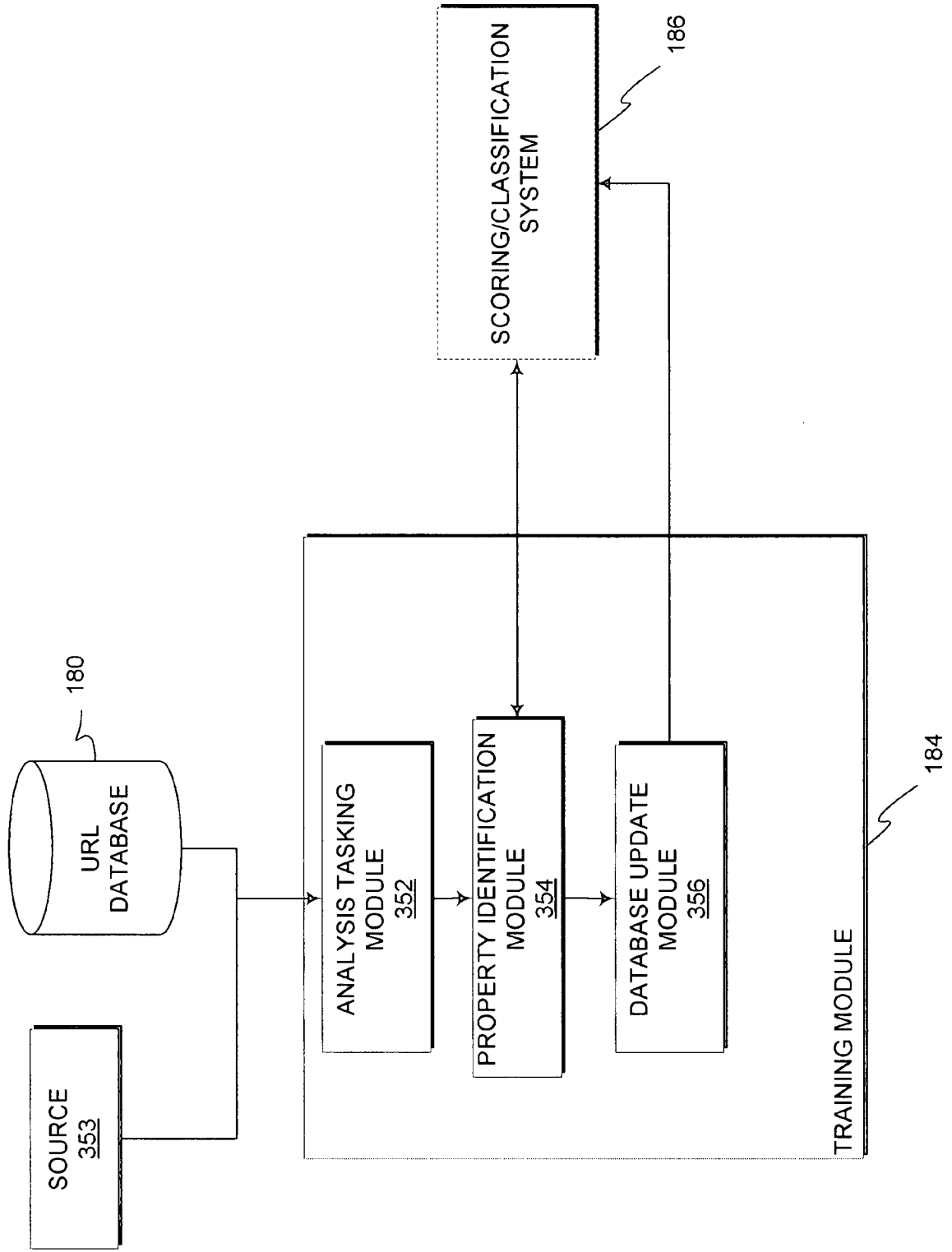

FIG. 14

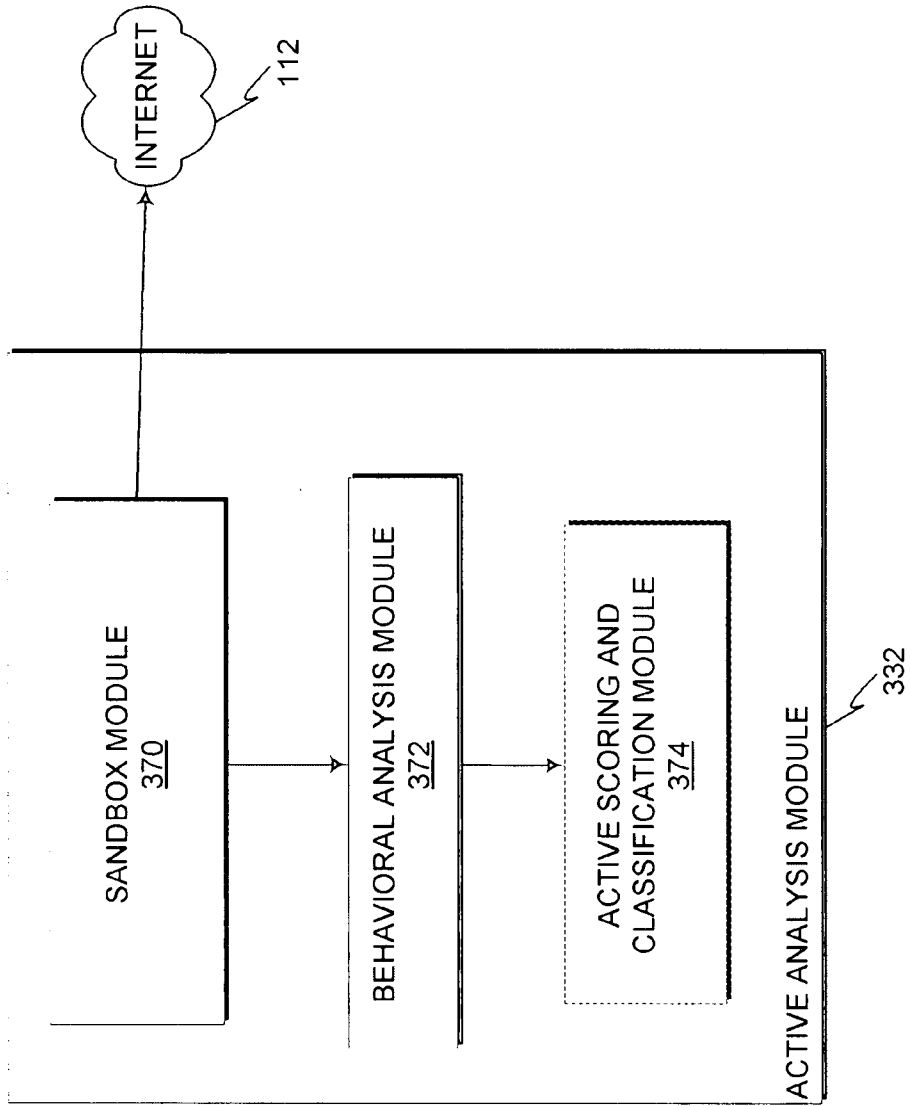

FIG. 15

2013206427 20 Jun 2013

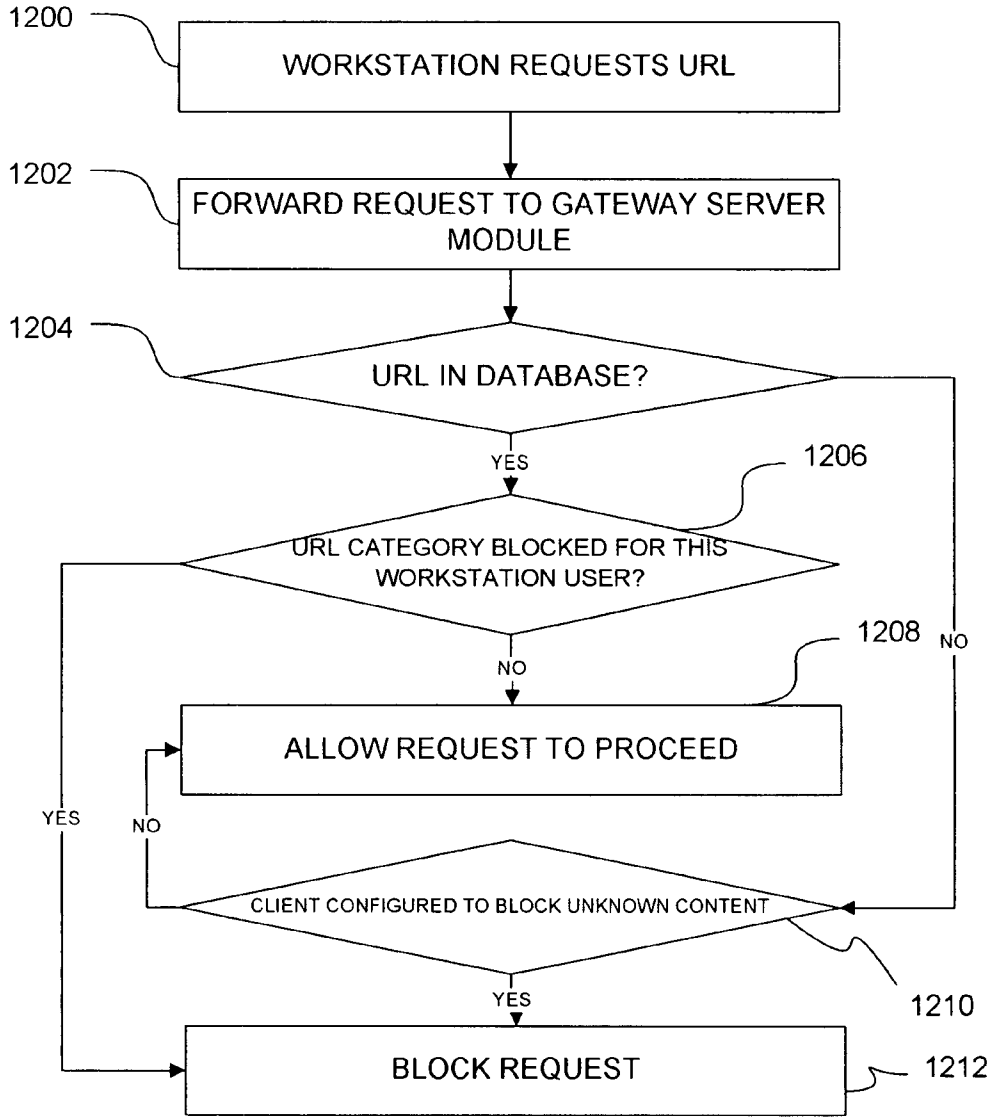

FIG. 16



2013206427 20 Jun 2013

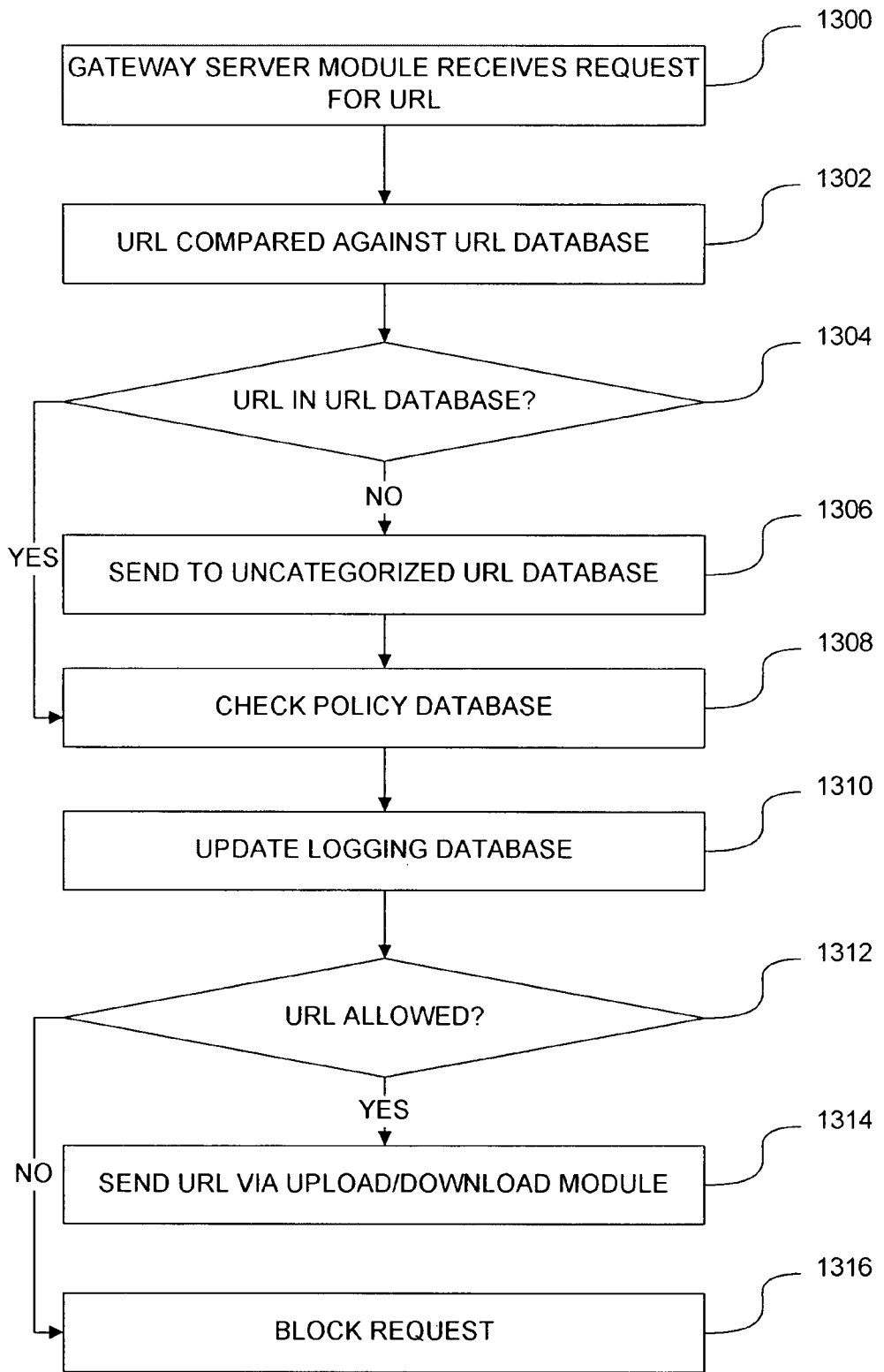

FIG. 17

2013206427 20 Jun 2013

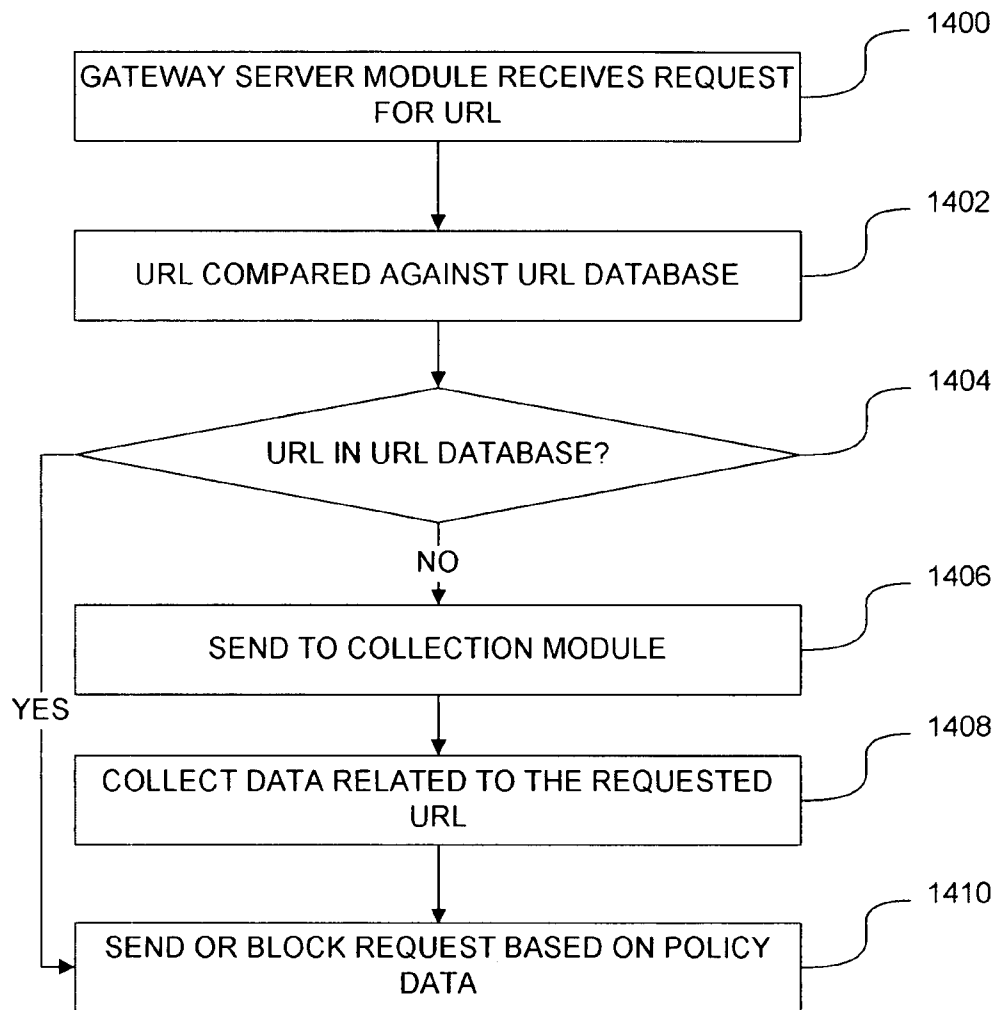

FIG. 18

2013206427 20 Jun 2013

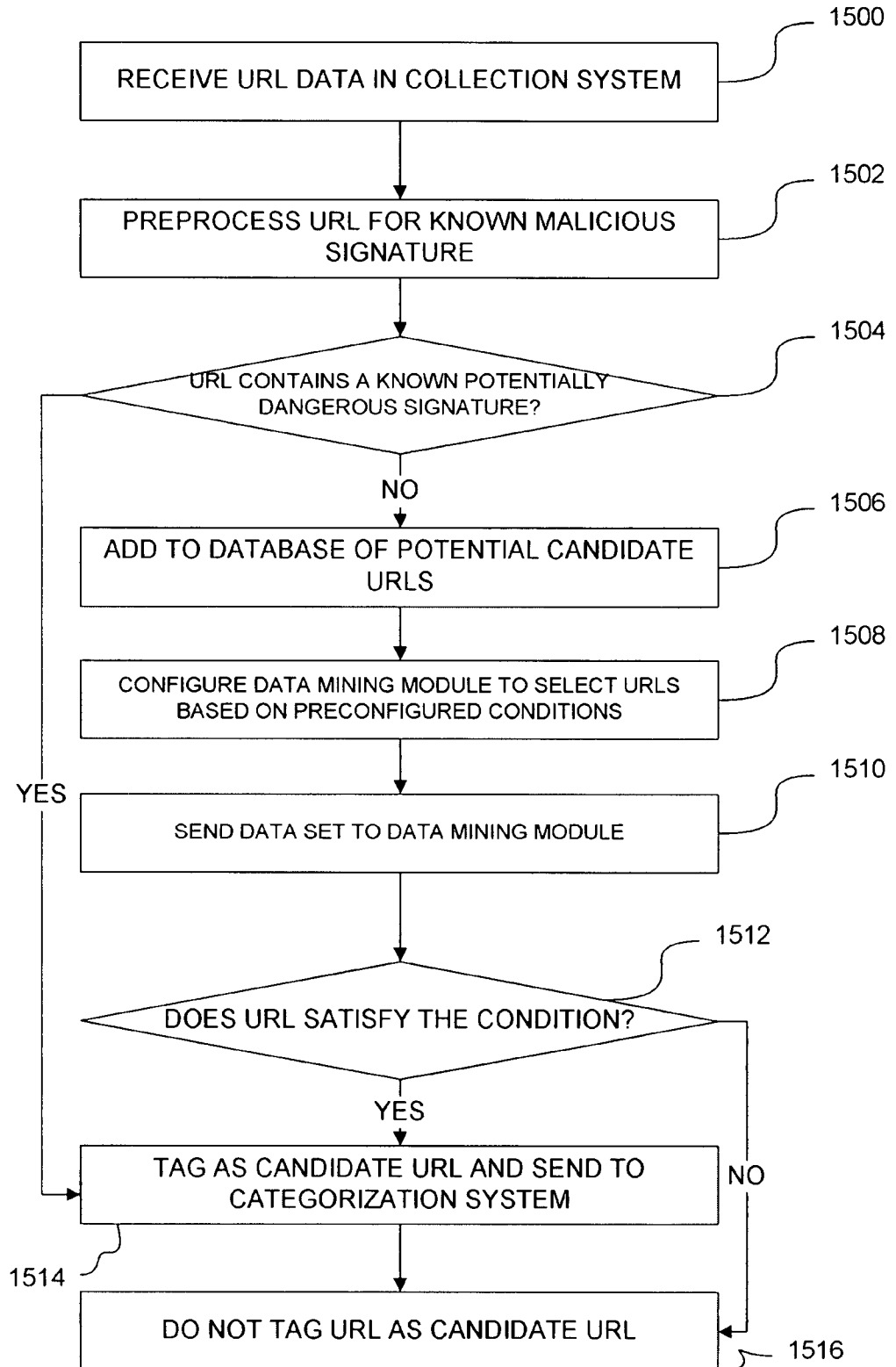

FIG. 19

2013206427 20 Jun 2013

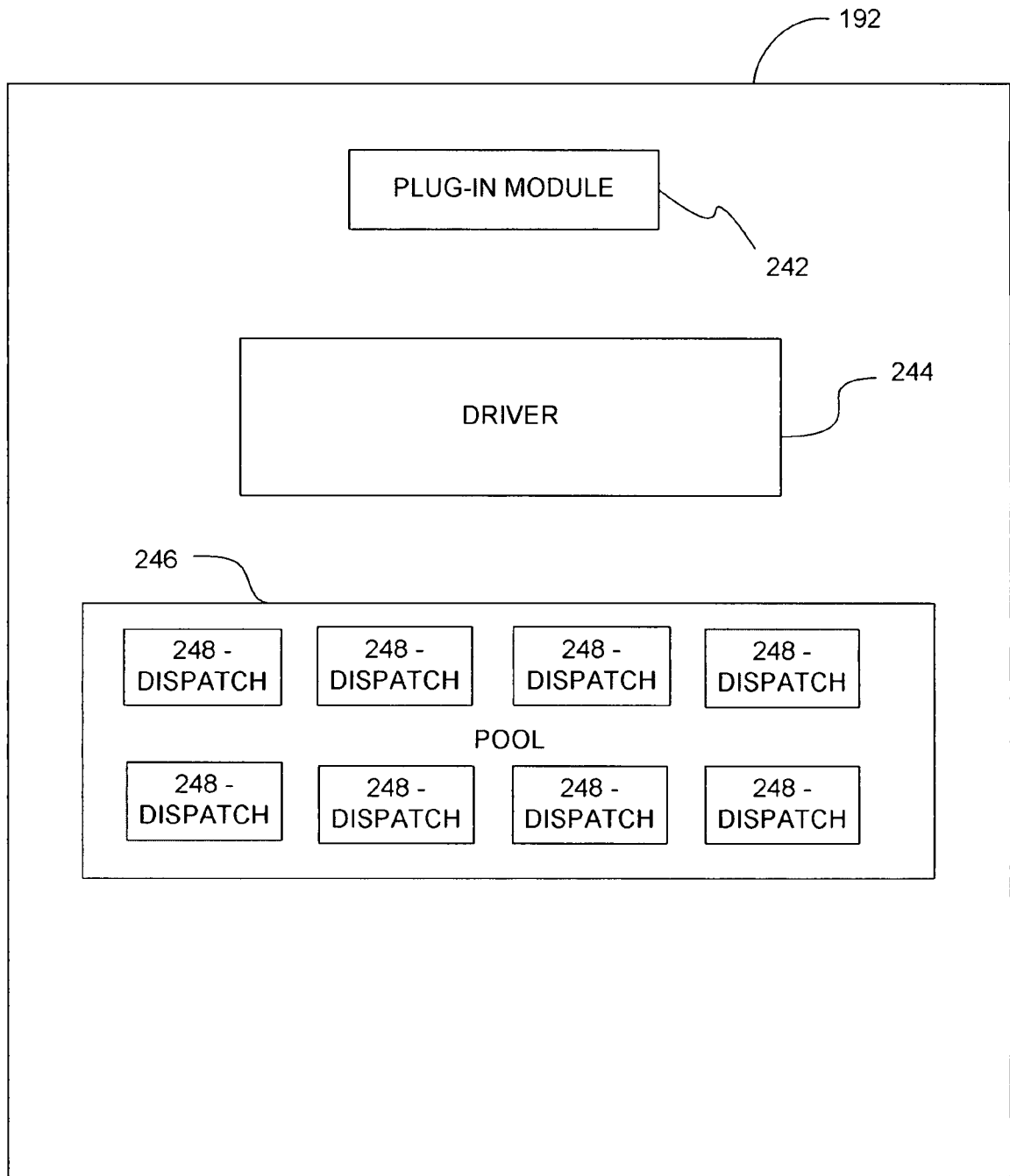

FIG. 20

2013206427 20 Jun 2013

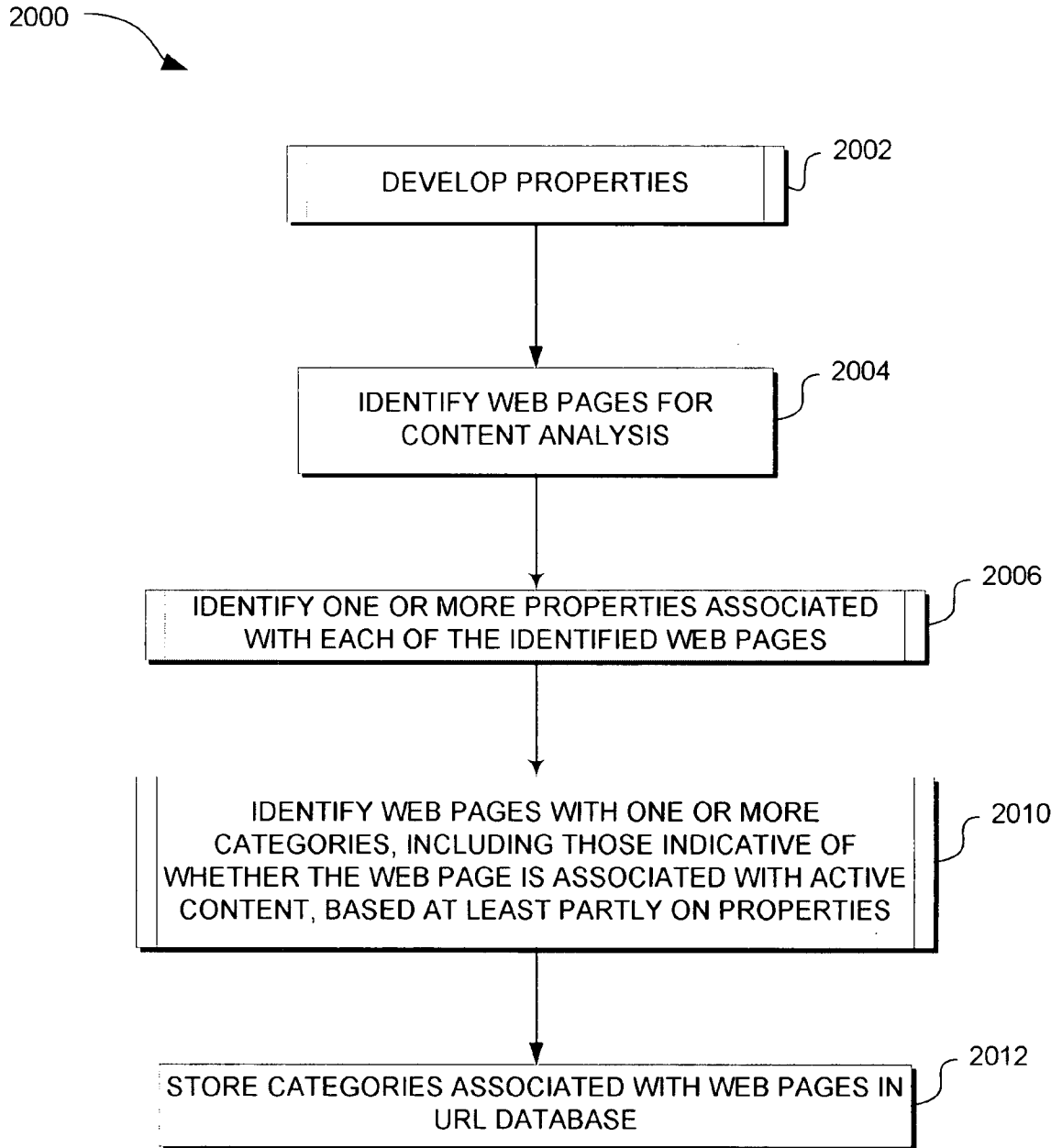

FIG. 21

2013206427 20 Jun 2013

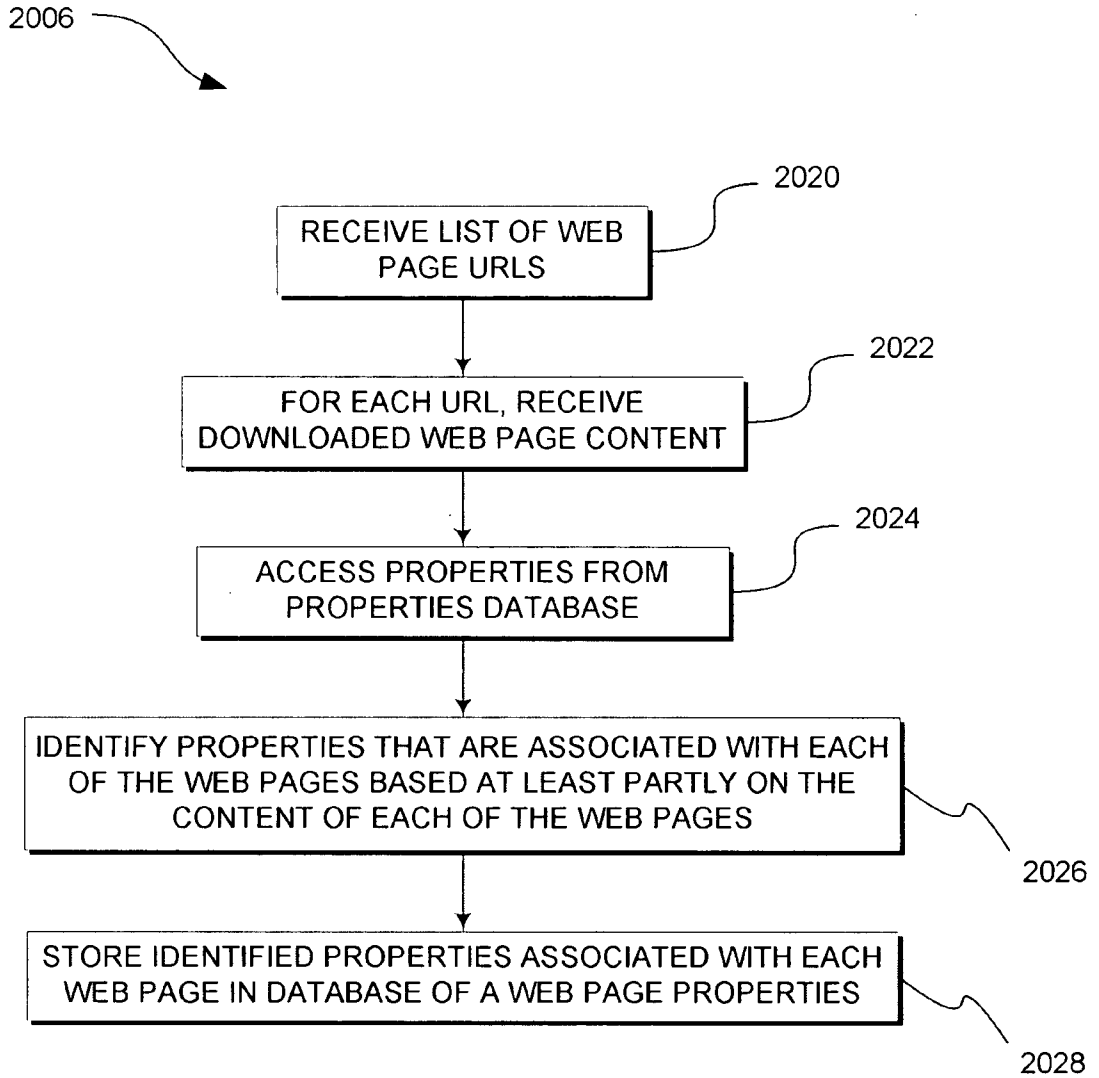

FIG. 22

2013206427 20 Jun 2013

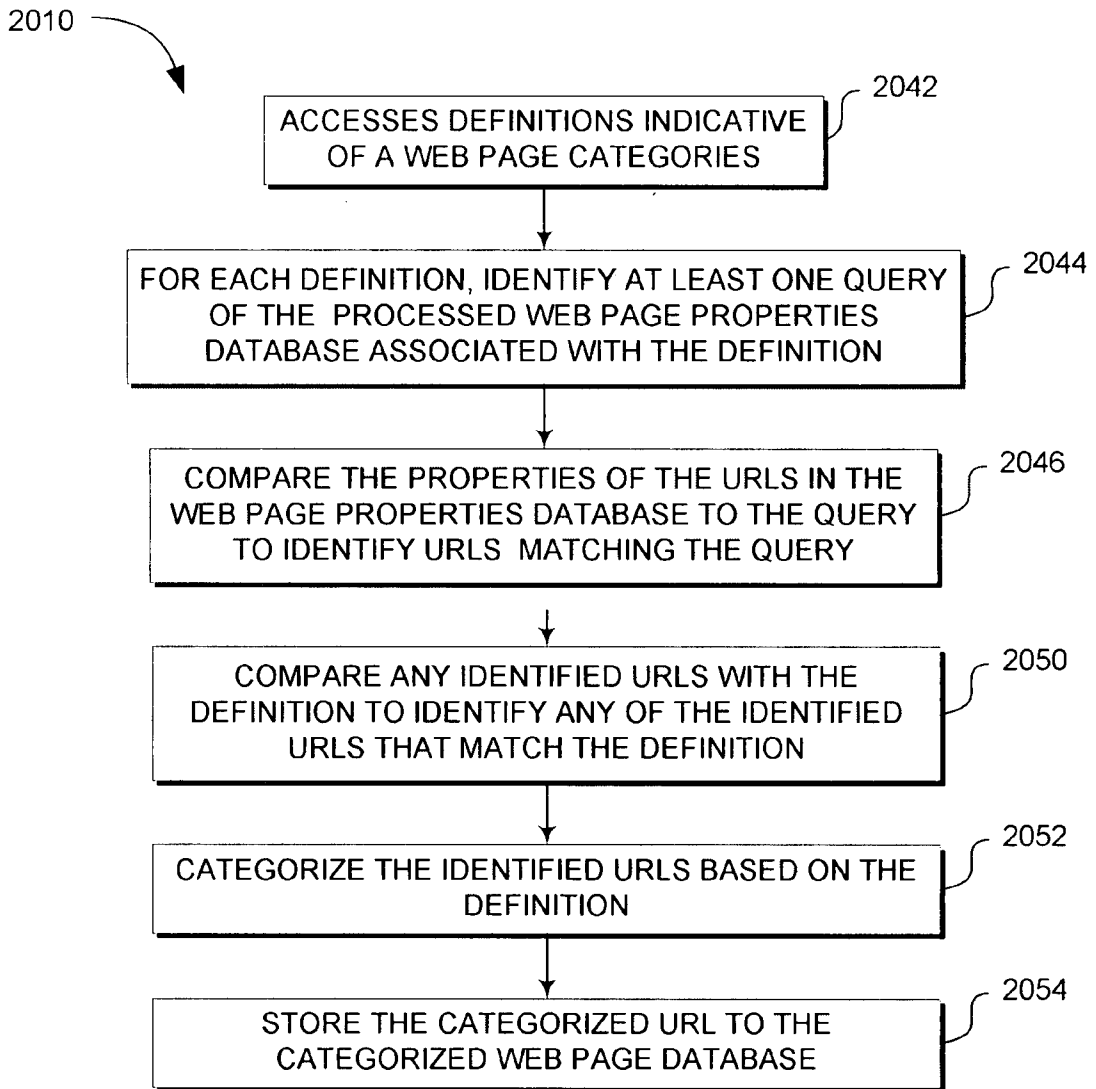

FIG. 23

2013206427 20 Jun 2013

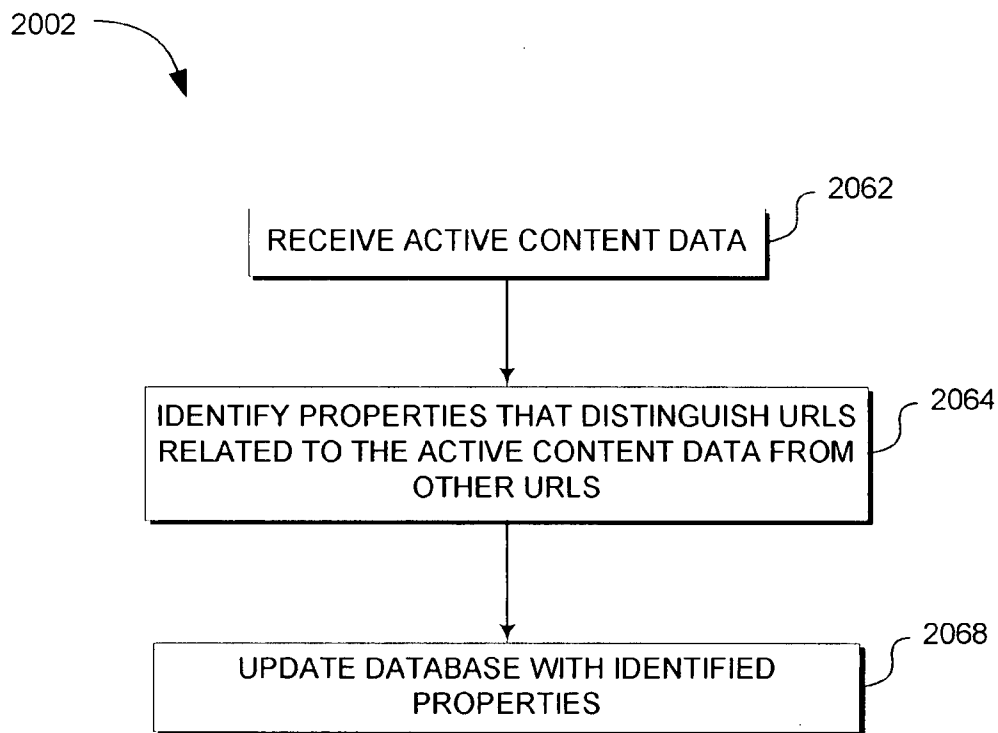

FIG. 24



2013206427 20 Jun 2013

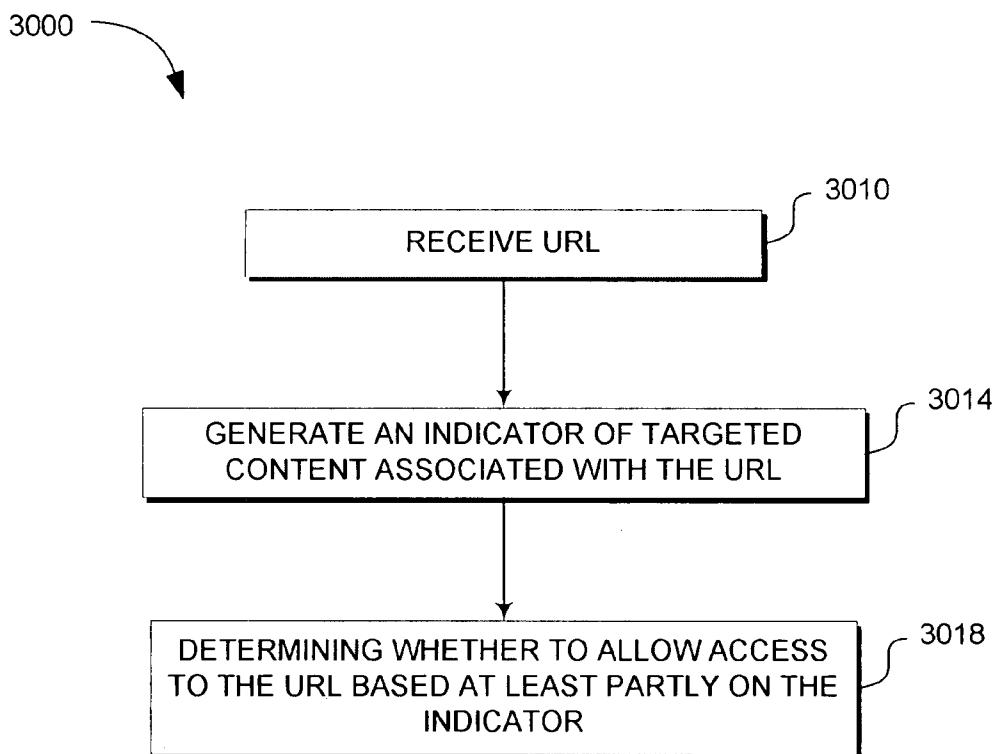

FIG. 25