

(19) World Intellectual Property
Organization
International Bureau



(43) International Publication Date
18 August 2005 (18.08.2005)

PCT

(10) International Publication Number
WO 2005/076409 A1

- (51) International Patent Classification⁷: H01Q 21/30, 1/38, 9/40, 1/22, G06F 1/16
- (21) International Application Number: PCT/EP2005/000879
- (22) International Filing Date: 28 January 2005 (28.01.2005)
- (25) Filing Language: English
- (26) Publication Language: English
- (30) Priority Data: 60/540,448 30 January 2004 (30.01.2004) US
- (71) Applicant (for all designated States except US): FRAC-TUS S.A. [ES/ES]; Avda. Alcalde Barnils 64-68, Edificio Testa - Modulo C3, Parque Empresarial Sant Joan, Sant Cugat del Valles, E-08190 Barcelona (ES).
- (72) Inventors; and
- (75) Inventors/Applicants (for US only): SOLER CAS-TANNY, Jordi [ES/ES]; Fray Luis de León, 19-21 àtic, E-08302 Mataró (ES). PUENTE BALIARDA, Carles [ES/ES]; Londres, 57 4^o 2a, E-08036 Barcelona (ES). BORJA BORAU, Carmen [ES/ES]; Tvra. de Dalt, 67, E-08024 Barcelona (ES).
- (74) Agent: BRACHMANN, Roland; Jones Day, Rechtsan-wälte Attorneys-at-Law, Prinzregentenstrasse 11, 80538 München (DE).
- (81) Designated States (unless otherwise indicated, for every kind of national protection available): AE, AG, AL, AM, AT, AU, AZ, BA, BB, BG, BR, BW, BY, BZ, CA, CH, CN, CO, CR, CU, CZ, DE, DK, DM, DZ, EC, EE, EG, ES, FI, GB, GD, GE, GH, GM, HR, HU, ID, IL, IN, IS, JP, KE, KG, KP, KR, KZ, LC, LK, LR, LS, LT, LU, LV, MA, MD, MG, MK, MN, MW, MX, MZ, NA, NL, NO, NZ, OM, PG, PH, PL, PT, RO, RU, SC, SD, SE, SG, SK, SL, SY, TJ, TM, TN, TR, TT, TZ, UA, UG, US, UZ, VC, VN, YU, ZA, ZM, ZW.
- (84) Designated States (unless otherwise indicated, for every kind of regional protection available): ARIPO (BW, GH, GM, KE, LS, MW, MZ, NA, SD, SL, SZ, TZ, UG, ZM, ZW), Eurasian (AM, AZ, BY, KG, KZ, MD, RU, TJ, TM), European (AT, BE, BG, CH, CY, CZ, DE, DK, EE, ES, FI, FR, GB, GR, HU, IE, IS, IT, LT, LU, MC, NL, PL, PT, RO, SE, SI, SK, TR), OAPI (BF, BJ, CF, CG, CI, CM, GA, GN, GQ, GW, ML, MR, NE, SN, TD, TG).

Published:
— with international search report

For two-letter codes and other abbreviations, refer to the "Guidance Notes on Codes and Abbreviations" appearing at the beginning of each regular issue of the PCT Gazette.

(54) Title: MULTI-BAND MONOPOLE ANTENNAS FOR MOBILE NETWORK COMMUNICATIONS DEVICES

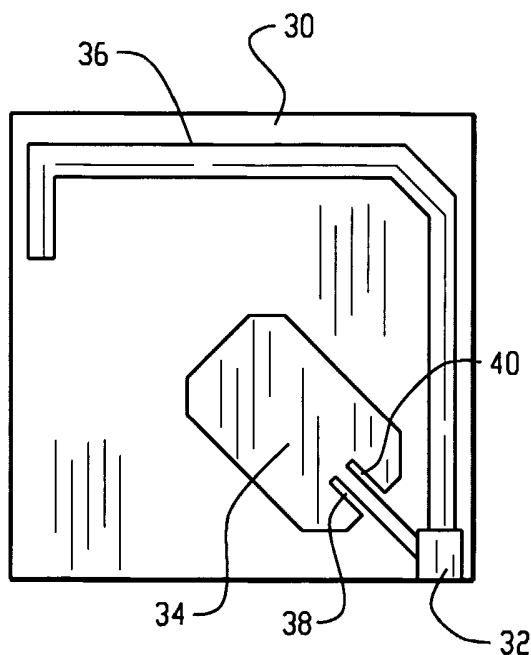

(57) Abstract: Multiband monopole antennas are disclosed. The antennas disclosed can include a substrate for mounting conductors, one or more conductors for receiving networking signals mainly in a first frequency band, and one or more conductors for receiving networking signals mainly in a second frequency band. The conductors can have a polygonal shape or the conductors can have a linear, space-filling, or grid dimension shape. The conductors can be connected at a feed point. One or more antenna can be incorporated into a single printed circuit board. When multiple antennas are used with the same printed circuit board, the conducting material of the printed circuit board located between the antenna attachment points can be interrupted to improve the isolation of each antenna.

WO 2005/076409 A1

MULTI-BAND MONOPOLE ANTENNAS FOR MOBILE NETWORK COMMUNICATIONS DEVICES

5

Introduction

This invention relates generally to the field of multi-band monopole antennas. More specifically, multi-band monopole antennas are provided that are particularly well-suited for use in mobile network communications devices, such as PCMCIA wireless cards, electronic devices with integrated WI-FI and WiMAX modules, compact flash wireless cards, wireless USB/UART dongles, and other wireless networking devices.

15 **BACKGROUND**

Multi-band antenna structures for use in a mobile network communications device are known in this art. In known wireless PCMCIA cards, for example, two dual-band antennas are typically used. The two antennas in a PCMCIA card, for example, are used with a diversity system in which the signal received from each antenna is compared and the best signal at any given time is used. A diversity system is particularly useful for indoor and multipath reception.

Summary

Multiband monopole antennas are disclosed. The antennas disclosed can include a substrate for mounting conductors, a first conductor for receiving networking signals mainly in a first frequency band, and a second conductor for receiving networking signals mainly in a second frequency band. The first conductor can have a polygonal shape with an aspect ratio of length to width of less than about 5

- 2 -

to about 1. The second conductor can be linear, space-filling, or grid dimension. The first and second conductors can be connected at a feeding point.

The antennas disclosed can also include a substrate for mounting conductors, first
5 and second conductors for receiving networking signals mainly in a first frequency band, and third and fourth conductors for receiving networking signals mainly in a second frequency band. The first and second conductors can be symmetrical polygonal shapes that have an aspect ratio of length to width of less than about 5 to about 1. The third and fourth conductors can be symmetrical linear,
10 space-filling, or grid dimension shapes. The first and second conductors can be symmetrically oriented with respect to each other about a central axis on the antenna substrate and the third and fourth conductors can be symmetrically oriented with respect to each other about the central axis on the antenna substrate. The first, second, third and fourth conductors can be connected at a feeding point.

15

The antennas can be formed on simple, readily available circuit board materials as separate units or formed directly onto a printed circuit board. Two or more of the disclosed antennas can be used on a single printed circuit board. When two or more antennas are used with the same printed circuit board, the conducting material of the printed circuit board located between the antenna attachment points can
20 be interrupted to improve the isolation of each antenna.

BRIEF DESCRIPTION OF THE DRAWINGS

Fig. 1 shows a top view of a multi-band monopole antenna for use in mobile network communications devices;
25

Fig. 2 shows a top view of another multi-band monopole antenna for use in mobile network communications devices;

30 Fig. 3 shows a top view of a non-symmetrical multibranch monopole antenna for use in mobile network communications devices;

- 3 -

Fig. 4 shows a top view of a symmetrical multibranch monopole antenna for use in mobile network communications devices;

5 Fig. 5 shows one example of a space-filling curve;

Figs. 6-9 illustrate an exemplary two-dimensional antenna geometry forming a grid dimension curve;

10 Fig. 10 shows a suggested carbus PCB layout for use with the antenna shown in Fig. 4; and

Fig. 11 shows another suggested carbus PCB layout for use with the antenna shown in Fig. 4.

15

DETAILED DESCRIPTION

Referring now to the drawing figures, Fig. 1 and Fig. 2 are top views of two exemplary multi-band monopole antennas for use in mobile network communications devices. The antennas of Fig. 1 and Fig. 2 include substrates (10, 20) and
20 multibranch monopole conductors with the branches being connected at common points called feeding points (12, 22). The antenna substrates of Fig. 1 and Fig. 2 can, for example, be a 10 mm × 10 mm × 0.8 mm circuit board with a copper base conductor. The number of branches of a monopole antenna is directly related to the number of frequency bands or groups of bands that can be received. The antennas of Fig. 1 and Fig. 2 have two branches and are, thus, capable of receiving
25 two different frequency bands. The branches of the antennas of Fig. 1 and Fig. 2 are non-symmetrical with the longer branch (14, 24) receiving a lower frequency band and the shorter branch (16, 26) receiving a higher frequency band. The length of the branches can be configured to receive signals specified in network-
30 ing standards such as the 802.11bg/Bluetooth standard (2.4-2.5 GHz) and the 802.11a band (4.9-5.875 GHz). Thus, the antennas of both Fig. 1 and Fig. 2 can

- 4 -

be configured, for example, to receive both 802.11bg band frequencies on the longer branch (14, 24) and 802.11a band frequencies on the shorter branch (16, 26). Coupling between branches in multibranch antennas is possible and such coupling can be taken into account during the design of the antenna. Further, services other than networking broadcast on these frequencies and the antennas disclosed herein can be used with those services as well.

Another multi-band monopole antenna design is shown in Fig. 3. The antenna of Fig. 3 is a non-symmetrical multibranch monopole. The antenna of Fig. 3 includes a substrate 30, a feeding point 32, and two conductor branches (34, 36). The shorter branch 34 is a polygonal monopole with notches (38, 40). The polygonal monopole could also have a multilevel shape such as that described in U.S. Patent Application Publication No. US 2002/0140615 A1, which is hereby incorporated by reference. The aspect ratio, i.e., the length compared to the width, of the shorter branch 34 of the polygonal monopole as depicted in Fig. 3 is about 3 to about 2. Preferably the aspect ratio is less than about 5 to about 1, more preferably the aspect ratio is less than about 3 to about 1, and even more preferably the aspect ratio is less than about 2 to about 1. The notches (38, 40) contribute to the antenna impedance match. One or more notches can be used, the length of each notch can vary, and, if more than one notch is used, the notches may be different lengths. A polygonal monopole can also have no notches. The longer branch 36 receives a lower frequency band and the shorter branch 34 receives a higher frequency band. The longer 36 and shorter 34 branches can be configured to receive network standard signals as discussed above with the antennas of Fig. 1 and Fig. 2.

Non-symmetrical antennas like the one shown in Fig. 3 are often designed for a specific printed circuit board (PCB) and, thus, are locked into a specific orientation on the PCB because the performance of the antenna can change with changes in the position, orientation, or identity of nearby circuitry. Symmetrical antennas on the other hand usually offer greater flexibility in terms of PCB placement be-

- 5 -

cause they are not as effected by changes in position, orientation, or identity of nearby circuitry.

Another multi-band monopole antenna is shown in Fig. 4. The antenna shown in
5 Fig. 4 is a symmetrical multibranch monopole antenna. The antenna of Fig. 4
includes a substrate 50, a feeding point 52, and four conductor branches (54, 56,
58, 60). Each conducting branch has an opposing mirror image conducting
branch that is symmetrical about a plane 61 that roughly divides the substrate 50
10 in half from top to bottom. The shorter branches (54, 56) are mirror images of
each other with respect to plane 61 and the longer branches (58, 60) are mirror
images of each other with respect to plane 61. The shorter branches (54, 56) are
polygonal monopoles with notches as discussed above with respect to the antenna
of Fig. 3. The longer branches (58, 60) receive a lower frequency band and the
shorter branches (54, 56) receive a higher frequency band. The longer branches
15 can be linear, space-filing, or grid dimension curves. The longer (58, 60) and
shorter (54, 56) branches can be configured to receive network standard signals as
discussed above with respect to the antennas of Fig. 1 and Fig. 2. Due to its
symmetry, the antenna of Fig. 4 has greater flexibility in terms of PCB placement
than the non-symmetrical antennas discussed above.

20

An example of a space-filling curve 62 is shown in Fig. 5. As used herein space-
filling means a curve formed from a line that includes at least ten segments, with
each segment forming an angle with an adjacent segment. When used in an an-
tenna, each segment in a space-filling curve 62 should be shorter than one-tenth of
25 the free-space operating wavelength of the antenna.

Examples of grid dimension curves are shown in Figs. 6 to 9. The grid dimension
of a curve may be calculated as follows. A first grid having square cells of length
L1 is positioned over the geometry of the curve, such that the grid completely
30 covers the curve. The number of cells (N1) in the first grid that enclose at least
a portion of the curve are counted. Next, a second grid having square cells of

- 6 -

length L2 is similarly positioned to completely cover the geometry of the curve, and the number of cells (N2) in the second grid that enclose at least a portion of the curve are counted. In addition, the first and second grids should be positioned within a minimum rectangular area enclosing the curve, such that no entire row or column on the perimeter of one of the grids fails to enclose at least a portion of the curve. The first grid should include at least twenty-five cells, and the second grid should include four times the number of cells as the first grid. Thus, the length (L2) of each square cell in the second grid should be one-half the length (L1) of each square cell in the first grid. The grid dimension (D_g) may then be calculated with the following equation:

$$D_g = -\frac{\log(N2) - \log(N1)}{\log(L2) - \log(L1)}$$

For the purposes of this application, the term grid dimension curve is used to describe a curve geometry having a grid dimension that is greater than one (1). The larger the grid dimension, the higher the degree of miniaturization that may be achieved by the grid dimension curve in terms of an antenna operating at a specific frequency or wavelength. In addition, a grid dimension curve may, in some cases, also meet the requirements of a space-filling curve, as defined above. Therefore, for the purposes of this application, a space-filling curve is one type of grid dimension curve.

Fig. 6 shows an exemplary two-dimensional antenna 64 forming a grid dimension curve with a grid dimension of approximately two (2). Fig. 7 shows the antenna 64 of Fig. 6 enclosed in a first grid 66 having thirty-two (32) square cells, each with length L1. Fig. 8 shows the same antenna 64 enclosed in a second grid 68 having one hundred twenty-eight (128) square cells, each with a length L2. The length (L1) of each square cell in the first grid 66 is twice the length (L2) of each square cell in the second grid 68 (L2 = 2 × L1). An examination of Figs. 7 and 8 reveal that at least a portion of the antenna 64 is enclosed within every square cell in both the first and second grids 66, 68. Therefore, the value of N1 in the above grid dimension (D_g) equation is thirty-two (32) (*i.e.*, the total number of cells in

- 7 -

the first grid 66), and the value of N2 is one hundred twenty-eight (128) (i.e., the total number of cells in the second grid 68). Using the above equation, the grid dimension of the antenna 64 may be calculated as follows:

$$D_g = -\frac{\log(128) - \log(32)}{\log(2 \times L1) - \log(L1)} = 2$$

- 5 For a more accurate calculation of the grid dimension, the number of square cells may be increased up to a maximum amount. The maximum number of cells in a grid is dependent upon the resolution of the curve. As the number of cells approaches the maximum, the grid dimension calculation becomes more accurate. If a grid having more than the maximum number of cells is selected, however, then
- 10 the accuracy of the grid dimension calculation begins to decrease. In some cases, the maximum number of cells is 100, but typically, the maximum number of cells in a grid is one thousand (1000).

- For example, Fig. 9 shows the same antenna 64 enclosed in a third grid 69 with
- 15 five hundred twelve (512) square cells, each having a length L3. The length (L3) of the cells in the third grid 69 is one half the length (L2) of the cells in the second grid 68, shown in Fig. 8. As noted above, a portion of the antenna 64 is enclosed within every square cell in the second grid 68, thus the value of N for the second grid 68 is one hundred twenty-eight (128). An examination of Fig. 9, however,
- 20 reveals that the antenna 64 is enclosed within only five hundred nine (509) of the five hundred twelve (512) cells in the third grid 69. Therefore, the value of N for the third grid 69 is five hundred nine (509). Using Figs. 8 and 9, a more accurate value for the grid dimension (D_g) of the antenna 64 may be calculated as follows:

$$D_g = -\frac{\log(509) - \log(128)}{\log(2 \times L2) - \log(L2)} \approx 1.9915$$

- 25 The performance aspects of multi-band monopole antennas can be effected by the layout of the metal in the PCB where an antenna is mounted. As discussed above, antennas can be designed to work within particular PCB environments or a PCB can be optimized to work with a particular antenna design. The specific design of the antenna shown in Fig. 3, for example, makes it particularly well-suited for use

- 8 -

with a cardbus PCB. To utilize the antenna shown in Fig. 3 with a cardbus PCB, two copies of the antennas shown in Fig. 3 could, for example, be mounted in the upper left corner and upper right corner of the cardbus PCB. Figs. 10 and 11 show examples of two PCBs suitable for use with the antenna of Fig. 4. In Fig. 10 and Fig. 11, two copies of the antenna of Fig. 4, for example, could be mounted in the upper left corners (80, 90) and upper right corners (82, 92). The PCBs of Fig. 10 and Fig. 11 include slots (84, 94) in the upper portion of the PCB. The slots (84, 94) provide an interruption in or absence of conducting material between antenna attachment positions. The slots (84, 94) allow the adjustment of the electrical path of the currents and fields that propagate along the conductive edge. An interruption in or absence of conducting material between antennas mounted on a PCB increases each antenna's isolation from the other antenna thereby potentially improving performance. In addition to slots, other interruptions that can be used include, but are not limited to, holes, FracPlane™ ground plates (such as those described in U.S. Patent Application Publication No. US 2004/0217916 A1, which is hereby incorporated by reference), and periodic, quasi-periodic, space-filling, multi-level, and frequency selective geometries. Further, one or more interruptions can be used. Figs. 10 and 11 show examples in which separate antenna components are mounted on a PCB. When an antenna is formed as a component separate from the PCB on which it will eventually be mounted, the substrate material used to make the antenna can be simple, readily available printed circuit board material. Further, directly forming an antenna on a particular PCB is also possible. In some embodiments, the antenna is formed directly on a substrate or laminate of an integrated circuit package including other electronic or radio frequency (RF) components or semiconductor dies.

This written description uses examples to disclose the invention, including the best mode, and also to enable a person skilled in the art to make and use the invention. The patentable scope of the invention is defined by the claims, and may include other examples that occur to those skilled in the art. Such other examples, which may be available either before or after the application filing date, are in-

tended to be within the scope of the claims if they have structural elements that do not differ from the literal language of the claims, or if they include equivalent structural elements with insubstantial differences from the literal language of the claims.

Claims

1. A multi-band monopole antenna, comprising:
5 an antenna substrate;
a first conductor for receiving networking signals in the frequency range of about 4.9 GHz to about 5.875 GHz, said first conductor having a polygonal shape with an aspect ratio of length to width of less than about 5 to about 1;
a second conductor for receiving networking signals in the frequency
10 range of about 2.4 GHz to about 2.5 GHz, said second conductor adopting a linear, space-filling, or grid dimension shape; and
a feeding point for connecting the first conductor and the second conductor.
- 15 2. The multi-band monopole antenna of claim 1, wherein the first conductor has one or more notches where material is removed from the polygonal shape for matching the impedance of the antenna.
3. The multi-band monopole antenna of claim 1, wherein the first conductor
20 has an aspect ratio of less than about 3 to about 1.
4. The multi-band monopole antenna of claim 1, wherein the first conductor has an aspect ratio of less than about 2 to about 1.
- 25 5. The multi-band monopole antenna of claim 1, wherein the first conductor has an aspect ratio of about 3 to about 2.
6. The multi-band monopole antenna of claim 1, wherein the first conductor receives network signals in the 802.11a band.

- 11 -

7. The multi-band monopole antenna of claim 1, wherein the second conductor receives network signals in the 802.11bg band.
8. The multi-band monopole antenna of claim 1, wherein the substrate comprises a 10 mm × 10 mm × 0.8 mm circuit board with a copper base conductor.
9. A printed circuit board comprising one or more of the multi-band monopole antennas of claim 1.
10. The printed circuit board of claim 9, wherein two or more multi-band monopole antennas are used and conducting material of the printed circuit board located between the antenna attachment points is interrupted.
11. A symmetrical multi-band monopole antenna, comprising:
an antenna substrate;
first and second conductors for receiving networking signals in the frequency range of about 4.9 GHz to about 5.875 GHz, said first and second conductors having symmetrical polygonal shapes with an aspect ratio of length to width of less than about 5 to about 1;
third and fourth conductors for receiving networking signals in the frequency range of about 2.4 GHz to about 2.5 GHz, said third and fourth conductors adopting symmetrical linear, space-filling, or grid dimension shapes; and
a feeding point for connecting the first, second, third and fourth conductors,
wherein the first and second conductors are symmetrically oriented with respect to each other about a central axis on the antenna substrate and the third and fourth conductors are symmetrically oriented with respect to each other about the central axis on the antenna substrate.

12. The symmetrical multi-band monopole antenna of claim 11, wherein the first and second conductors have one or more notches where material is removed from the polygonal shape for matching the impedance of the antenna.
- 5 13. The symmetrical multi-band monopole antenna of claim 11, wherein the first and second conductors each have an aspect ratio of less than about 3 to about 1.
14. The symmetrical multi-band monopole antenna of claim 11, wherein the
10 first and second conductors each have an aspect ratio of less than about 2 to about 1.
15. The symmetrical multi-band monopole antenna of claim 11, wherein the first and second conductors each have an aspect ratio of about 3 to about 2.
- 15 16. The symmetrical multi-band monopole antenna of claim 11, wherein the first and second conductor receives network signals in the 802.11a band.
17. The symmetrical multi-band monopole antenna of claim 11, wherein the
20 second and third conductors receive network signals in the 802.11bg band.
18. The symmetrical multi-band monopole antenna of claim 11, wherein the substrate comprises a 10 mm × 10 mm × 0.8 mm circuit board with a copper base conductor.
- 25 19. A printed circuit board comprising one or more of the symmetrical multi-band monopole antennas of claim 11.
20. The printed circuit board of claim 9, wherein two or more symmetrical
30 multi-band monopole antennas are used and conducting material of the printed circuit board located between the antenna attachment points is interrupted.

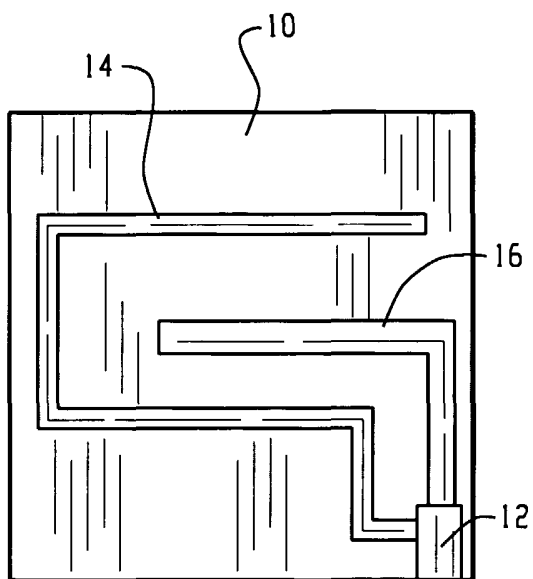

Fig. 1

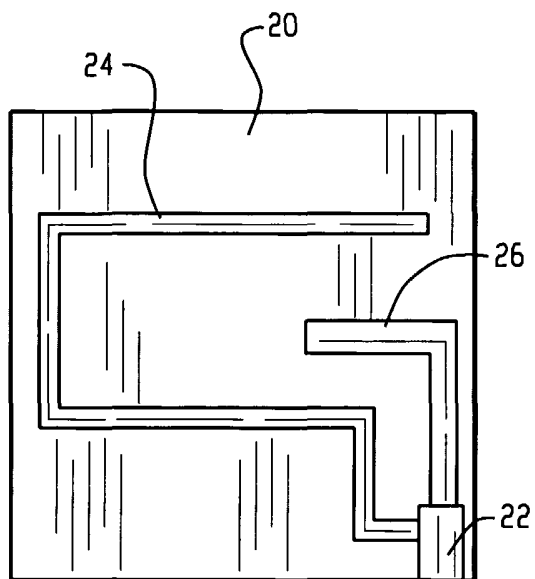

Fig. 2

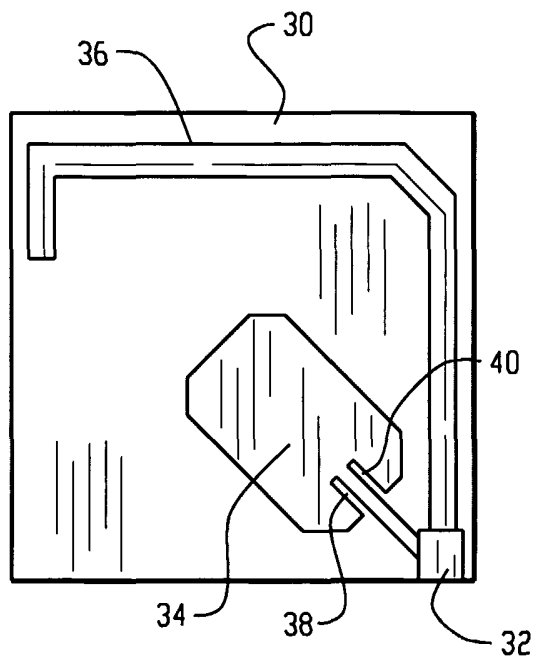

Fig. 3

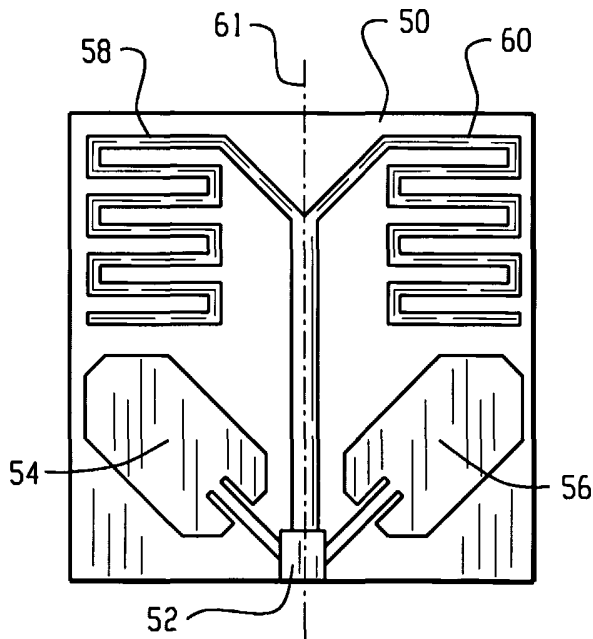

Fig. 4

2/7

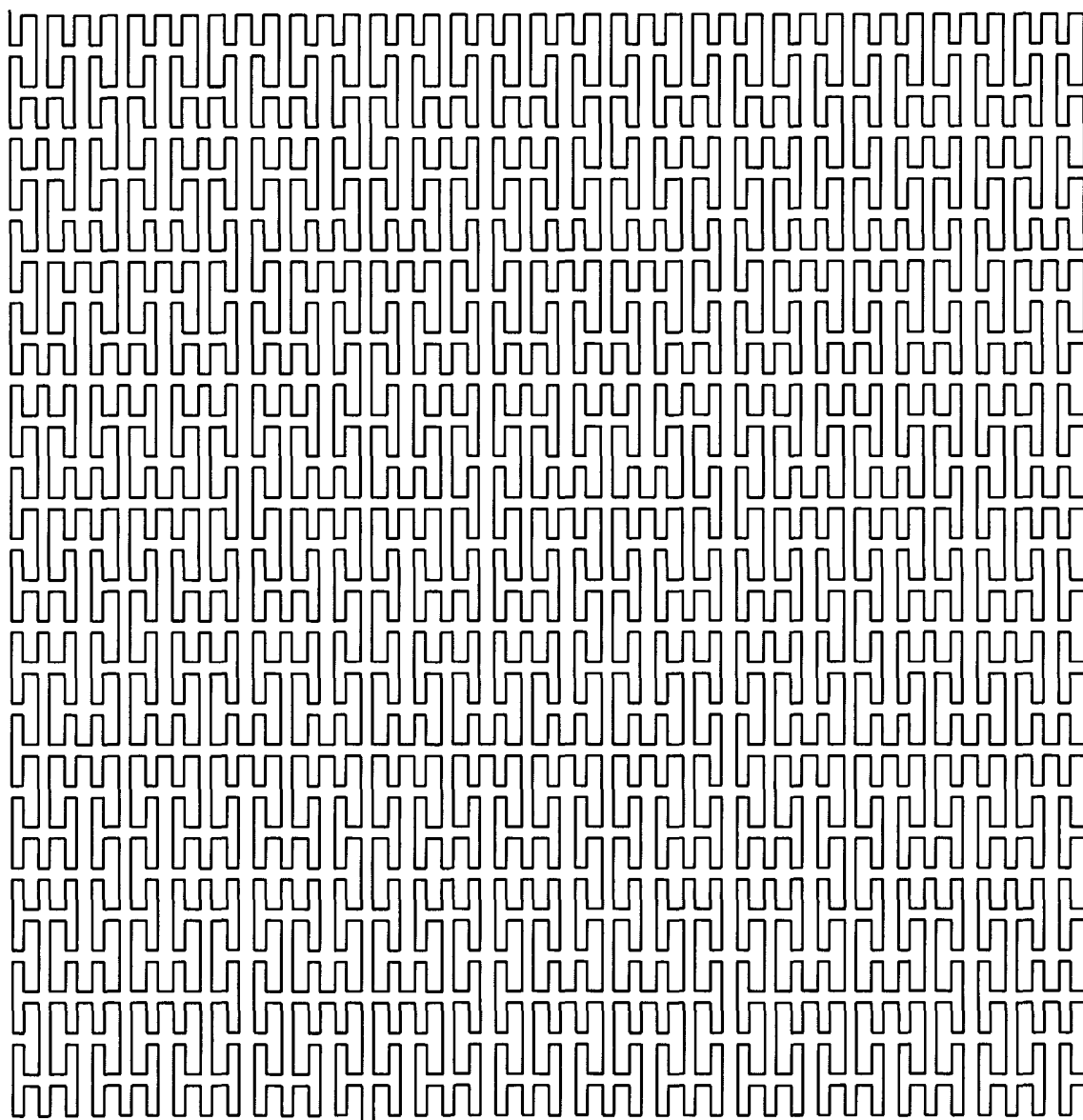
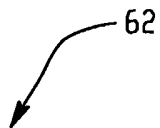

Fig. 5

3/7

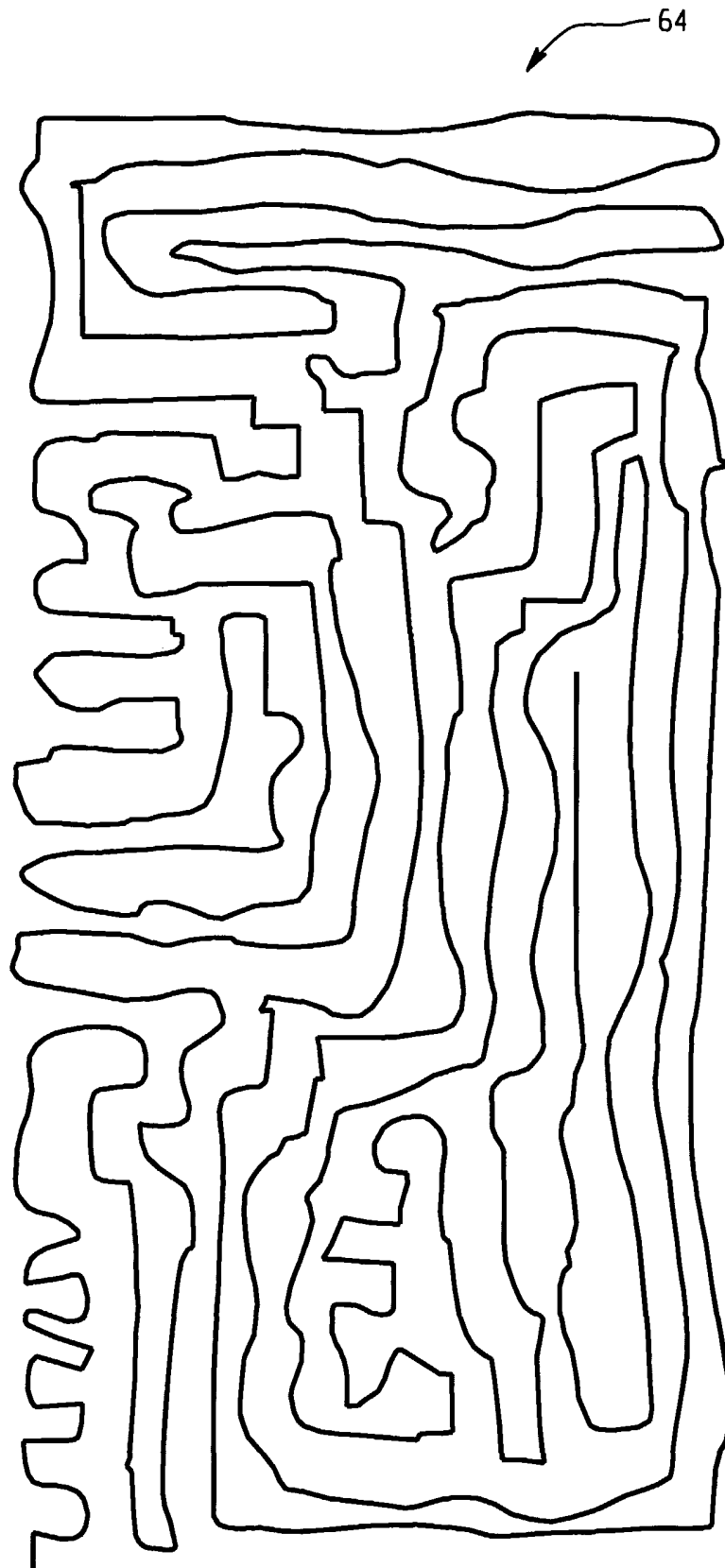

Fig. 6

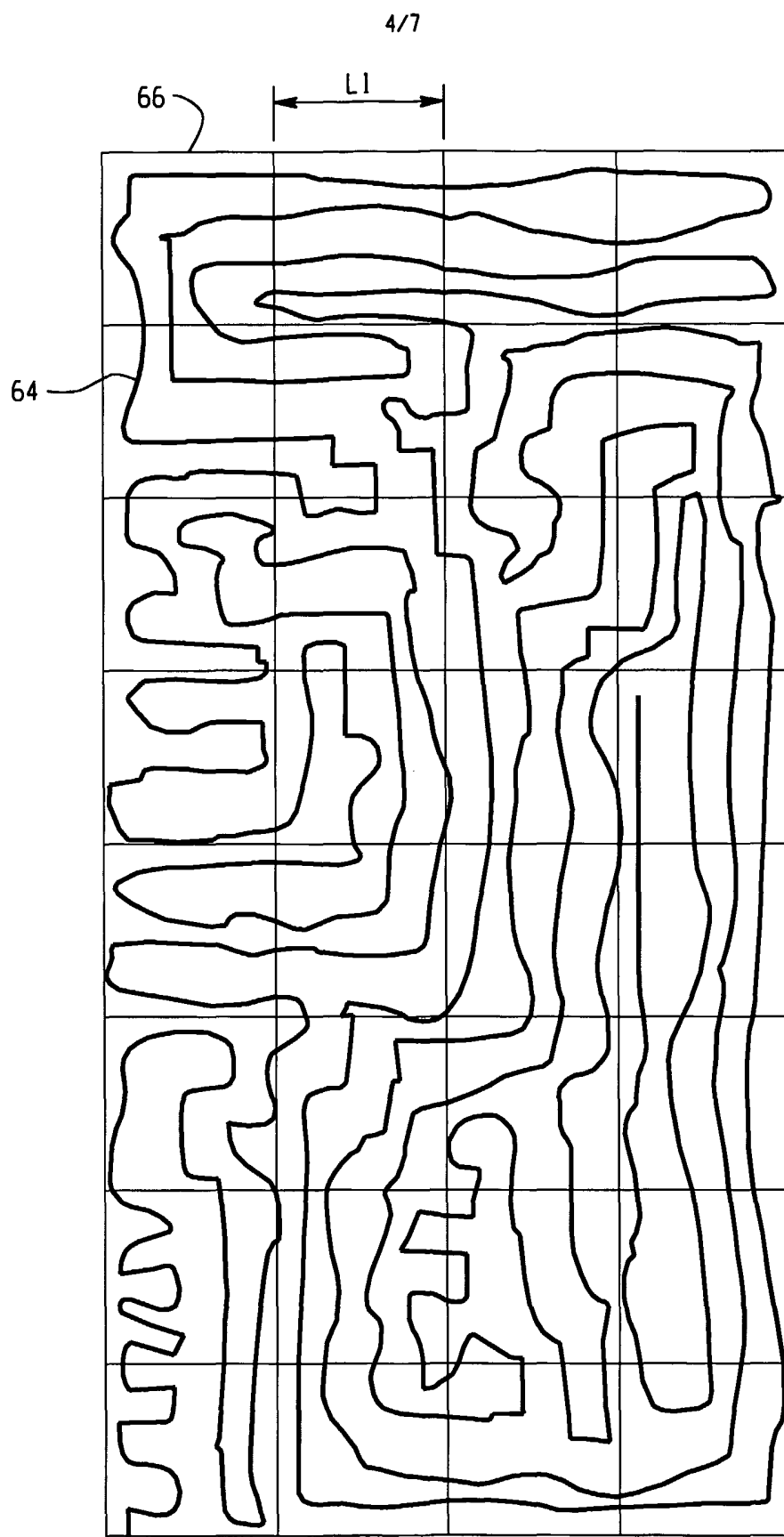

Fig. 7

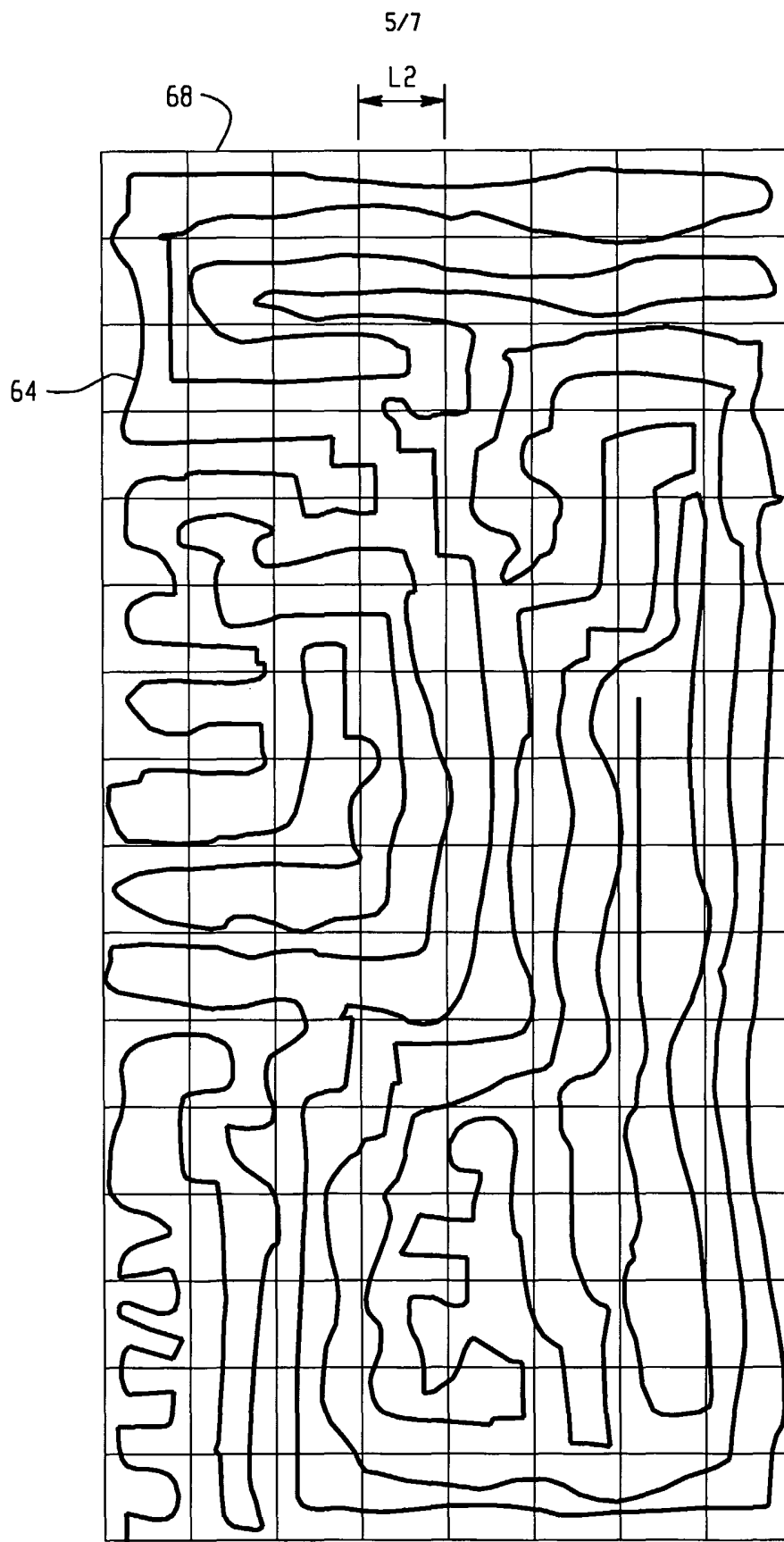

Fig. 8

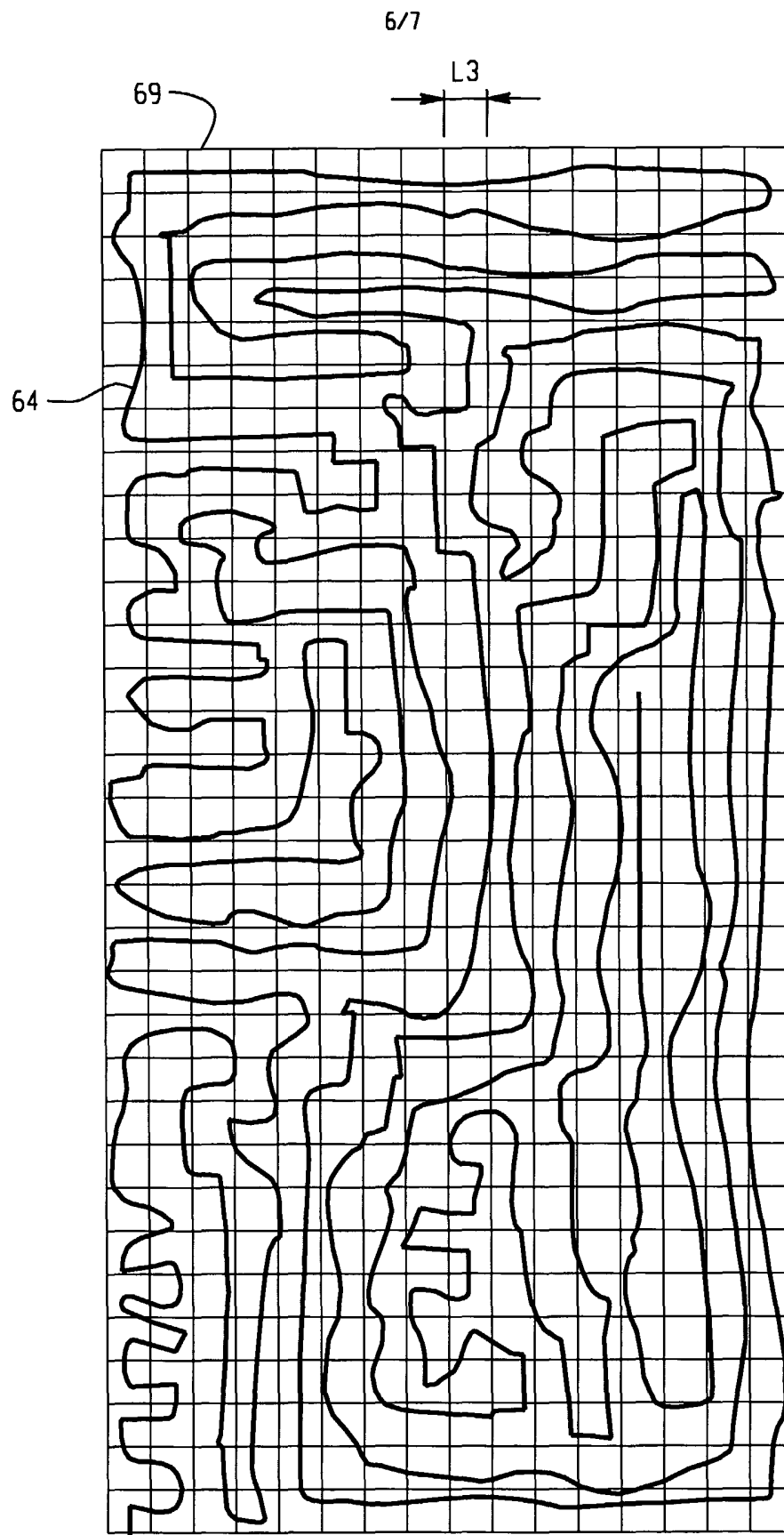

Fig. 9

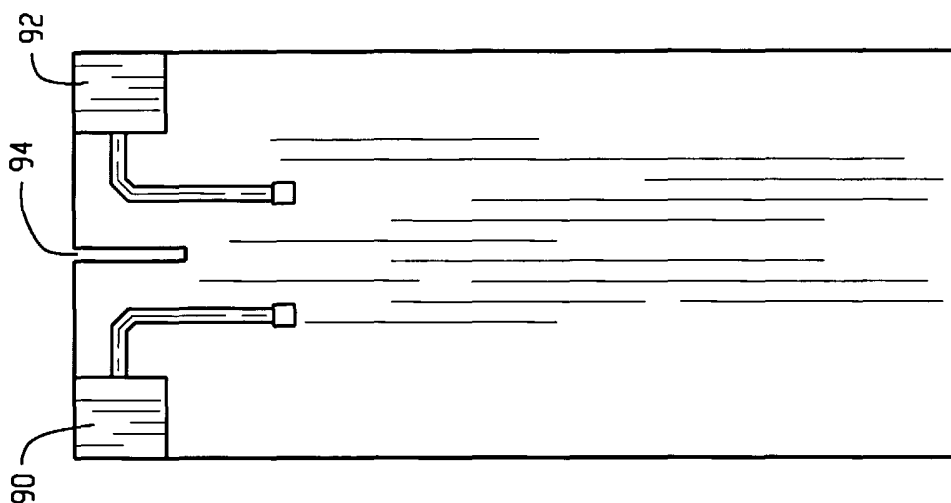

Fig. 11

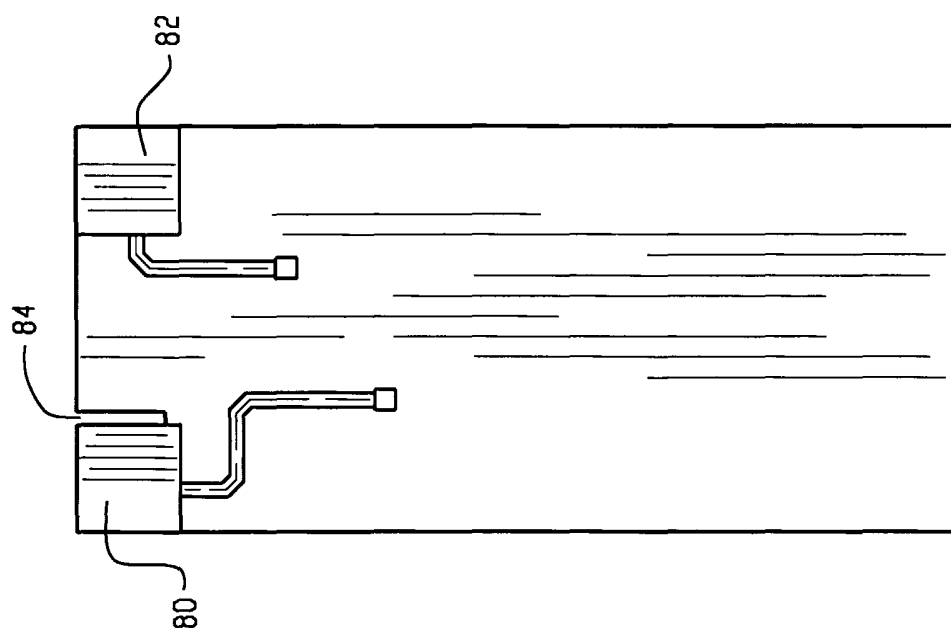

Fig. 10

INTERNATIONAL SEARCH REPORT

International Application No
PCT/EP2005/000879

A. CLASSIFICATION OF SUBJECT MATTER		
IPC 7	H01Q21/30	H01Q1/38 H01Q9/40 H01Q1/22 G06F1/16
According to International Patent Classification (IPC) or to both national classification and IPC		
B. FIELDS SEARCHED		
Minimum documentation searched (classification system followed by classification symbols) IPC 7 H01Q G06F		
Documentation searched other than minimum documentation to the extent that such documents are included in the fields searched		
Electronic data base consulted during the international search (name of data base and, where practical, search terms used) EPO-Internal, WPI Data, PAJ, INSPEC		
C. DOCUMENTS CONSIDERED TO BE RELEVANT		
Category °	Citation of document, with indication, where appropriate, of the relevant passages	Relevant to claim No.
X	US 2003/210187 A1 (WONG KIN LU ET AL) 13 November 2003 (2003-11-13) pages 2-3; figures 1,7a,7b	1,6,7,9, 11,16, 17,19
X		8,18
Y		2-5, 12-15
Y		10,20
X	PATENT ABSTRACTS OF JAPAN vol. 2003, no. 12, 5 December 2003 (2003-12-05) -& JP 2003 347828 A (SONY CORP), 5 December 2003 (2003-12-05) abstract	1
Y		10,20
	----- -/--	
<input checked="" type="checkbox"/> Further documents are listed in the continuation of box C. <input checked="" type="checkbox"/> Patent family members are listed in annex.		
° Special categories of cited documents :		
A document defining the general state of the art which is not considered to be of particular relevance *E* earlier document but published on or after the international filing date *L* document which may throw doubts on priority claim(s) or which is cited to establish the publication date of another citation or other special reason (as specified) *O* document referring to an oral disclosure, use, exhibition or other means *P* document published prior to the international filing date but later than the priority date claimed		*T* later document published after the international filing date or priority date and not in conflict with the application but cited to understand the principle or theory underlying the invention *X* document of particular relevance; the claimed invention cannot be considered novel or cannot be considered to involve an inventive step when the document is taken alone *Y* document of particular relevance; the claimed invention cannot be considered to involve an inventive step when the document is combined with one or more other such documents, such combination being obvious to a person skilled in the art. *&* document member of the same patent family
Date of the actual completion of the international search 29 April 2005		Date of mailing of the international search report 10/05/2005
Name and mailing address of the ISA European Patent Office, P.B. 5818 Patentlaan 2 NL - 2280 HV Rijswijk Tel. (+31-70) 340-2040, Tx. 31 651 epo nl, Fax: (+31-70) 340-3016		Authorized officer Ribbe, J

INTERNATIONAL SEARCH REPORT

 International Application No
 PCT/EP2005/000879

C.(Continuation) DOCUMENTS CONSIDERED TO BE RELEVANT		
Category °	Citation of document, with indication, where appropriate, of the relevant passages	Relevant to claim No.
Y	US 4 356 492 A (KALOI ET AL) 26 October 1982 (1982-10-26) pages 1A,2A, column 2, lines 39-66 -----	2-5, 12-15
X	WO 02/078123 A (TELEFONAKTIEBOLAGET L M ERICSSON ; BOLIN, THOMAS; YING, ZHINONG; ANDER) 3 October 2002 (2002-10-03) the whole document -----	1
X	EP 1 367 671 A (NGK SPARK PLUG CO., LTD) 3 December 2003 (2003-12-03) the whole document -----	1
P,A	US 2004/217916 A1 (QUINTERO ILLERA RAMIRO 'ES! ET AL) 4 November 2004 (2004-11-04) cited in the application the whole document -----	1,11
A	& WO 03/023900 A (FRACTUS, S.A; QUINTERO ILLERA, RAMIRO; PUENTE BALIARDA, CARLES) 20 March 2003 (2003-03-20) the whole document -----	1,11
A	US 2002/140615 A1 (CARLES PUENTE BALIARDA ET AL) 3 October 2002 (2002-10-03) cited in the application the whole document -----	1,3-5, 11,13-15

INTERNATIONAL SEARCH REPORT

Information on patent family members

International Application No
PCT/EP2005/000879

Patent document cited in search report	Publication date	Patent family member(s)	Publication date
US 2003210187	A1	13-11-2003	NONE
JP 2003347828	A	05-12-2003	NONE
US 4356492	A	26-10-1982	NONE
WO 02078123	A	03-10-2002	SE 518988 C2 17-12-2002 EP 1378021 A1 07-01-2004 SE 0102183 A 24-09-2002 WO 02078123 A1 03-10-2002 US 2004137950 A1 15-07-2004
EP 1367671	A	03-12-2003	JP 2003347827 A 05-12-2003 EP 1367671 A2 03-12-2003 US 2004001031 A1 01-01-2004
US 2004217916	A1	04-11-2004	WO 03023900 A1 20-03-2003 BR 0117125 A 28-09-2004 CN 1545749 A 10-11-2004 EP 1425820 A1 09-06-2004 JP 2005503062 T 27-01-2005 MX PA04002384 A 31-05-2004
WO 03023900	A	20-03-2003	WO 03023900 A1 20-03-2003 BR 0117125 A 28-09-2004 CN 1545749 A 10-11-2004 EP 1425820 A1 09-06-2004 JP 2005503062 T 27-01-2005 MX PA04002384 A 31-05-2004 US 2004217916 A1 04-11-2004
US 2002140615	A1	03-10-2002	WO 0122528 A1 29-03-2001 AT 292329 T 15-04-2005 AU 5984099 A 24-04-2001 BR 9917493 A 16-07-2002 CN 1379921 A 13-11-2002 EP 1223637 A1 17-07-2002 JP 2003510871 T 18-03-2003 MX PA02003084 A 20-08-2003