



(12) **United States Design Patent**
Pathy et al.

(10) **Patent No.:** **US D938,095 S**
(45) **Date of Patent:** **** Dec. 7, 2021**

(54) **LIGHTING DEVICE**

- (71) Applicant: **Pathy Medical, LLC**, Shelton, CT (US)
- (72) Inventors: **Vinod V. Pathy**, Madison, CT (US);
Bob Pedros, Oxford, CT (US)
- (73) Assignee: **Pathy Medical, LLC**, Shelton, CT (US)
- (**) Term: **15 Years**
- (21) Appl. No.: **29/653,200**
- (22) Filed: **Jun. 13, 2018**

Related U.S. Application Data

- (63) Continuation-in-part of application No. 15/849,827, filed on Dec. 21, 2017, now Pat. No. 10,816,147, (Continued)

(51) **LOC (13) Cl.** **26-04**

(52) **U.S. Cl.**
USPC **D26/113**

(58) **Field of Classification Search**
USPC D26/24, 25, 26, 27, 60-69, 72, 74, 75,
D26/76, 77, 78, 80, 81, 82, 83, 85, 86,
(Continued)

(56) **References Cited**

U.S. PATENT DOCUMENTS

2,242,536 A 5/1941 Montgomery
4,539,003 A 9/1985 Tucker
(Continued)

FOREIGN PATENT DOCUMENTS

CA 79913 * 2/1997
CA 102076 * 4/2005
(Continued)

OTHER PUBLICATIONS

“Eveready Compact LED Metal Flashlight,” Sep. 1, 2004, amazon.com, site visited Apr. 12, 2021, URL: <https://www.amazon.com/Eveready-Compact-Flashlight-Resistant-Batteries/dp/B00EFKV1C2> (Year: 2004).*

(Continued)

Primary Examiner — Eric L Goodman

Assistant Examiner — Sarah L Smith

(74) *Attorney, Agent, or Firm* — McCarter & English, LLP

(57) **CLAIM**

The ornamental design for a lighting device, as shown and described.

DESCRIPTION

FIG. 1 is a front perspective view of a lighting device; FIG. 2 is a rear perspective view of the lighting device of FIG. 1;

FIG. 3 is a front view of the lighting device of FIG. 1; FIG. 4 is a rear view of the lighting device of FIG. 1; FIG. 5 is a top view of the lighting device of FIG. 1, the bottom view being a mirror image thereof; and, FIG. 6 is a right side view of the lighting device of FIG. 1, the left side view being a mirror image thereof.

The broken lines show structure that is not part of the claimed design, but rather are directed to environment in which the design is associated, or show portions of the article on which the design is embodied or applied, and are for illustrative purposes only. The broken lines form no part of the claimed design. The oblique shading lines indicate transparent or translucent surfaces. The oblique shading lines on the lens of the lighting device indicate transparent or translucent surfaces that are clear.

1 Claim, 3 Drawing Sheets

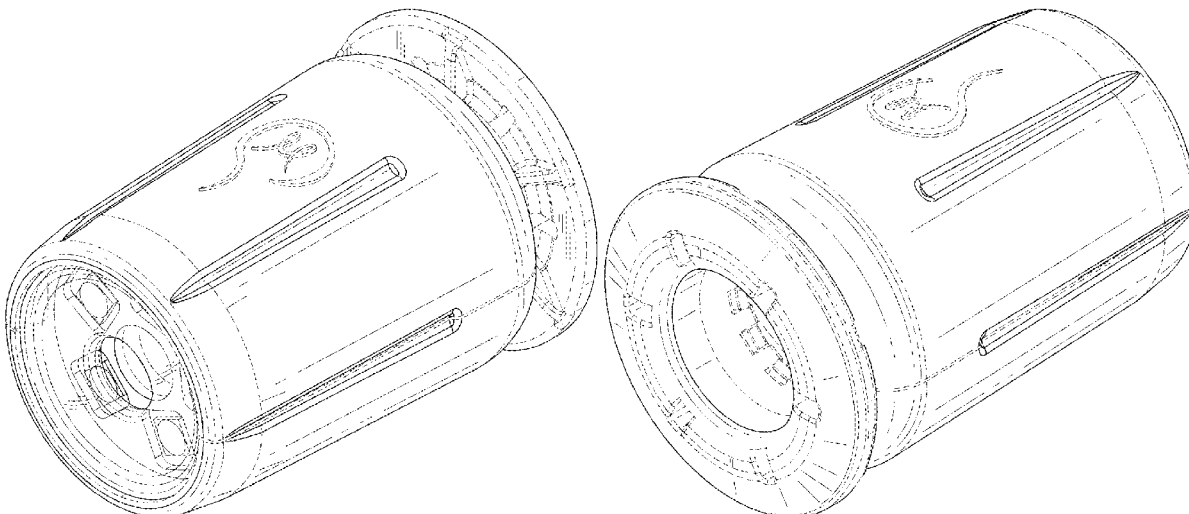

Related U.S. Application Data

which is a continuation of application No. 14/242, 819, filed on Apr. 1, 2014, now Pat. No. 9,851,060.

(60) Provisional application No. 61/853,232, filed on Apr. 1, 2013.

(58) **Field of Classification Search**

USPC D26/88, 89, 93, 104, 106, 108–115, 118, D26/120; D10/111–115
 CPC F21S 8/02; F21S 8/03; F21S 8/04; F21S 8/06; F21S 8/026; F21S 8/046; F21S 8/088; F21S 8/033; F21S 8/37; F21S 8/048; F21S 8/083; F21S 2/00; F21V 15/00; F21V 15/01; F21V 17/164; F21V 23/026

See application file for complete search history.

(56)

References Cited

U.S. PATENT DOCUMENTS

4,542,741 A 9/1985 Burgin
 4,619,248 A 10/1986 Walsh
 4,657,012 A 4/1987 Burgin
 5,281,134 A 1/1994 Schultz
 5,683,246 A 11/1997 Coss et al.
 5,692,863 A 12/1997 Louw
 5,716,320 A 2/1998 Buttermore
 5,785,408 A 7/1998 Tseng
 5,845,986 A 12/1998 Breen
 5,908,433 A 6/1999 Eager et al.
 5,928,140 A 7/1999 Hardten
 5,967,971 A 10/1999 Bolser
 6,080,105 A 6/2000 Spears
 6,084,422 A 7/2000 Bartholomew
 6,095,810 A 8/2000 Blanchett
 6,129,662 A 10/2000 Li et al.
 6,196,968 B1 3/2001 Rydin et al.
 6,213,621 B1 4/2001 Chien
 6,223,633 B1 5/2001 Chien-Chieh
 6,228,025 B1 5/2001 Hipps et al.
 6,277,064 B1 8/2001 Yoon
 6,322,499 B1 11/2001 Evans et al.
 6,325,522 B1 12/2001 Walian
 6,358,244 B1 3/2002 Newman et al.
 6,379,065 B2 4/2002 Perry et al.
 6,394,950 B1 5/2002 Weiss
 6,409,705 B1 6/2002 Kondo
 6,428,180 B1 8/2002 Karram et al.
 6,496,718 B1 12/2002 Lonky
 6,497,654 B1 12/2002 Leonard et al.
 6,504,985 B2 1/2003 Parker et al.
 6,517,551 B1 2/2003 Driskill
 6,540,390 B2 4/2003 Toth et al.
 6,554,768 B1 4/2003 Leonard
 6,585,727 B1 7/2003 Cashman et al.
 6,602,188 B2 8/2003 Bolser
 6,648,902 B2 11/2003 Colgan et al.
 6,739,744 B2 5/2004 Williams et al.
 6,769,911 B2 8/2004 Buchalla et al.
 6,805,666 B2 10/2004 Holland et al.
 6,817,978 B2 11/2004 Holland et al.
 6,955,444 B2 10/2005 Gupta
 6,971,989 B2 12/2005 Yossepowitch
 6,988,814 B1 1/2006 Correa
 7,008,076 B2 3/2006 Zirk
 7,063,436 B2 6/2006 Steen et al.
 7,083,613 B2 8/2006 Treat
 7,106,523 B2 9/2006 McLean et al.
 7,108,395 B2 9/2006 Correa
 7,141,015 B2 11/2006 Ruane
 7,270,439 B2 9/2007 Horrell et al.
 7,309,341 B2 12/2007 Ortiz et al.
 7,322,135 B2 1/2008 Gulati
 7,390,298 B2 6/2008 Chu

7,393,114 B2 7/2008 Devlin
 7,399,101 B2 7/2008 Clausen et al.
 7,481,766 B2 1/2009 Lee et al.
 D587,832 S * 3/2009 Bergmann F21V 21/0885 D26/63
 7,500,947 B2 3/2009 Kucklick
 7,503,894 B2 3/2009 Vankoski et al.
 7,534,104 B2 5/2009 Schneider
 7,631,981 B2 12/2009 Miller et al.
 7,748,979 B2 7/2010 Nahlieli
 7,832,914 B2 11/2010 Liu
 7,922,378 B2 4/2011 Bausenwein et al.
 7,927,240 B2 4/2011 Lynch
 7,954,687 B2 6/2011 Zemlok et al.
 7,976,559 B2 7/2011 Goldfarb et al.
 8,038,439 B2 10/2011 Schatz et al.
 8,047,987 B2 11/2011 Grey et al.
 8,075,553 B2 12/2011 Scheller et al.
 8,131,380 B2 3/2012 Cao et al.
 8,132,949 B2 3/2012 Vayser et al.
 8,152,718 B2 4/2012 Cheng
 8,162,852 B2 4/2012 Norris
 8,172,834 B2 5/2012 Bhadri et al.
 8,186,864 B2 5/2012 Komazaki et al.
 8,246,230 B2 8/2012 Todd et al.
 8,267,855 B2 9/2012 Barker
 8,328,402 B2 12/2012 O'Leary et al.
 8,371,848 B2 2/2013 Okawa et al.
 8,377,049 B2 2/2013 Cho et al.
 8,403,843 B2 3/2013 Bruto Da Costa
 8,419,428 B2 4/2013 Lawrence
 8,469,707 B2 6/2013 Emde
 8,485,972 B2 7/2013 Papac et al.
 8,496,475 B2 7/2013 Jamnia
 8,506,565 B2 8/2013 DeCarlo
 8,556,485 B2 10/2013 Geuder et al.
 8,636,658 B2 1/2014 Su et al.
 8,684,577 B2 4/2014 Vayser
 8,690,872 B2 4/2014 Jayaraj
 8,721,539 B2 5/2014 Shohat et al.
 8,758,224 B2 6/2014 Viola
 8,876,709 B2 11/2014 Vayser et al.
 8,876,713 B2 11/2014 Subramaniam
 8,882,756 B2 11/2014 Greeley et al.
 8,968,347 B2 3/2015 McCollam
 9,005,115 B2 4/2015 Vayser
 9,011,323 B2 4/2015 Vayser et al.
 9,023,039 B2 5/2015 Kerr
 9,050,048 B2 6/2015 Nadershahi et al.
 9,055,935 B2 6/2015 Grey et al.
 9,060,707 B2 6/2015 Grey et al.
 9,072,452 B2 7/2015 Vayser et al.
 9,107,650 B2 8/2015 Bjork et al.
 9,125,587 B2 9/2015 Hawkins et al.
 9,903,575 B2 * 2/2018 Ilenbiluan F21V 23/008
 D832,482 S * 10/2018 Price F21V 23/008 D26/63
 10,401,001 B2 * 9/2019 Kennedy A61B 90/35 600/249
 D887,624 S * 6/2020 Debelak B25B 15/02 D26/113
 D903,931 S * 12/2020 Guan A61B 90/361
 10,883,675 B1 * 1/2021 Hsu A61B 18/22
 10,907,807 B1 * 2/2021 Hsu A61B 1/0017
 2004/0166475 A1 8/2004 Nikolov
 2004/0242970 A1 12/2004 Burns
 2005/0065496 A1 3/2005 Simon et al.
 2006/0189849 A1 8/2006 Sharratt et al.
 2006/0282072 A1 12/2006 DesRosier
 2007/0049927 A1 3/2007 Saltzman
 2007/0060795 A1 3/2007 Vayser et al.
 2007/0066872 A1 3/2007 Morrison et al.
 2007/0093693 A1 4/2007 Geist et al.
 2007/0110496 A1 5/2007 Cetera
 2008/0147058 A1 6/2008 Horrell et al.
 2008/0266840 A1 10/2008 Nordmeyer et al.
 2008/0266845 A1 * 10/2008 Wu B25B 15/02 362/157
 2008/0275435 A1 11/2008 Nadolski

(56)

References Cited

U.S. PATENT DOCUMENTS

2009/0054890 A1 2/2009 DeCarlo
 2009/0198108 A1 8/2009 Chen et al.
 2010/0030033 A1 2/2010 Farley et al.
 2010/0106015 A1 4/2010 Norris
 2010/0118555 A1 5/2010 Lee
 2010/0125172 A1 5/2010 Jayaraj
 2010/0190129 A1 7/2010 Paz
 2010/0274097 A1 10/2010 Cho et al.
 2010/0312241 A1 12/2010 Erickson, Jr.
 2011/0060332 A1 3/2011 Cheng
 2011/0143304 A1 6/2011 Jamnia et al.
 2011/0190768 A1 8/2011 Shvetsov et al.
 2011/0257488 A1 10/2011 Koyama et al.
 2011/0261583 A1 10/2011 Geuder et al.
 2011/0279056 A1 11/2011 Waelti et al.
 2011/0289780 A1 12/2011 Tieg
 2012/0059226 A1 3/2012 Funt
 2012/0149992 A1 6/2012 Duggal et al.
 2012/0219923 A1 8/2012 Kert
 2012/0221000 A1 8/2012 Bromley et al.
 2012/0283718 A1 11/2012 Cosmescu
 2012/0283728 A1* 11/2012 Cosmescu A61B 90/35
 606/46
 2013/0183629 A1* 7/2013 Gan F21V 29/20
 2013/0197317 A1* 8/2013 Daniel A61B 90/35
 600/249
 2013/0267787 A1 10/2013 Warnock
 2013/0331657 A1 12/2013 Basson
 2014/0081086 A1 3/2014 Shvetsov et al.
 2014/0293590 A1* 10/2014 Pathy F21V 33/0068
 362/119
 2015/0025324 A1 1/2015 Wan
 2015/0238088 A1 8/2015 Hufnagel et al.
 2016/0178182 A1* 6/2016 Maglica F21L 4/005
 2016/0184046 A1* 6/2016 Blain A61B 17/1604
 600/249
 2016/0287062 A1* 10/2016 Kesten A61B 1/0017
 2017/0122525 A1* 5/2017 Cook
 2019/0101270 A1* 4/2019 Cramer, Jr. F21S 8/022
 D26/113
 2019/0336218 A1* 11/2019 Hammerland, III ... A61B 18/22
 2020/0337796 A1* 10/2020 Mezrich A61B 90/361
 2020/0345446 A1* 11/2020 Kimball A61B 17/07207
 2020/0378590 A1* 12/2020 Cohen F21K 9/20

2021/0048173 A1* 2/2021 Li F21V 15/01
 2021/0066990 A1* 3/2021 Rohner H02K 5/173
 2021/0068823 A1* 3/2021 Nicholas A61B 17/0686

FOREIGN PATENT DOCUMENTS

CN 3477209 * 9/2005
 CN 200982612 Y 11/2007
 DE 202004002963 U1 4/2004
 EM 002312173-0001 * 9/2013
 EP 3719389 A1 * 10/2020 F21V 17/12
 JP H07275261 A 10/1995
 JP 2000316874 A 11/2000
 JP 2005193012 A 7/2005
 JP 2005312727 A 11/2005
 JP 2009153785 A 7/2009
 JP 2012034804 A 2/2012
 JP 3174490 U 3/2012
 JP 5967971 B2 * 8/2016
 RU 2355562 C1 5/2009
 WO 2006065271 A2 6/2006
 WO 2013036625 A1 3/2013
 WO WO 2016194005 A1 * 12/2016 F21K 9/23

OTHER PUBLICATIONS

“Amscope UTP200X003MP Digital 2MP USB Microscope,” Nov. 22, 2013, amazon.com, site visited Apr. 12, 2021, URL: https://www.amazon.com/UTP200X003MP-Microscope-10X-200X-Magnification-Software/dp/B00GUTDMXW/ref=sr_1_4?dchild=1&keywords=medical+compact+led+light+source&qid=1618232909&sr=8-4 (Year: 2013).
 “HHIP 8401-0445 LED Goose Neck Work Light,” Jul. 11, 2013, amazon.com, site visited Apr. 12, 2021, URL: <https://www.amazon.com/HHIP-8401-0445-Goose-Magnetic-Flexible/dp/B01ADBMY3G> (Year: 2013).
 “Drpathynepsc,” Oct. 26, 2018, instagram.com, site visited Feb. 8, 2021, URL: https://www.instagram.com/p/BpaNjrmH_L/ (Year: 2018).
 “Light Jacket,” Oct. 4, 2018, manualslib.com, site visited Feb. 8, 2021, URL: <https://www.manualslib.com/manual/1660032/Pathy-Medical-Light-Jacket-Pm-Lj100.html?page=3#manua> (Year: 2018).
 MarineBuzz.com, “Use LED Clever Collar to Light Up Your Work Space,” website printout from <https://web.archive.org/web/20080918055357/http://www.marinebuzz.com/2008/09/14/use-led-clever-collar-to-light-up-your-work-space/>, Sep. 14, 2008, 1 page.

* cited by examiner

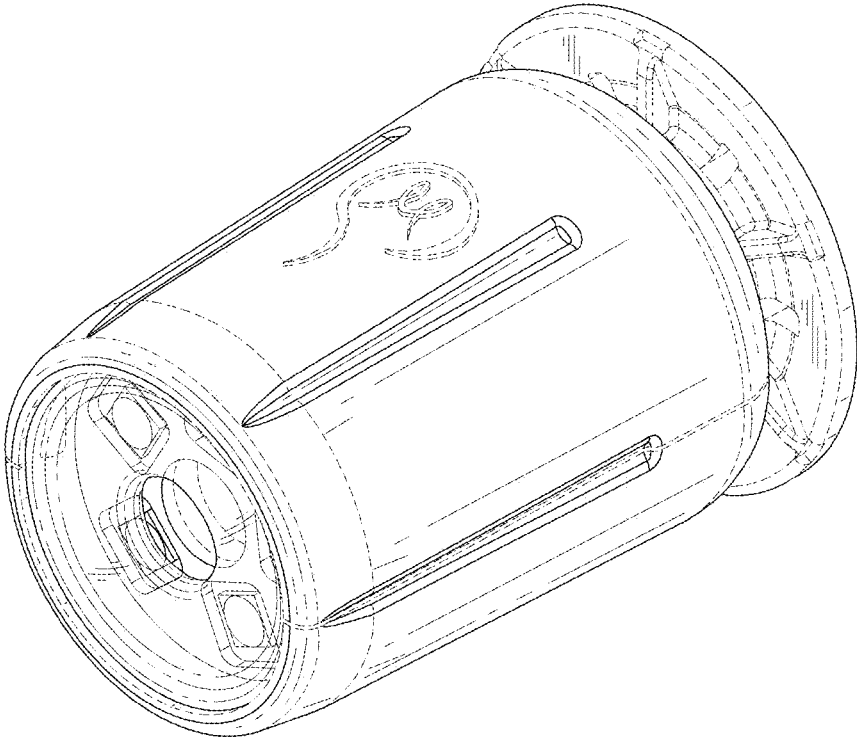

FIG. 1

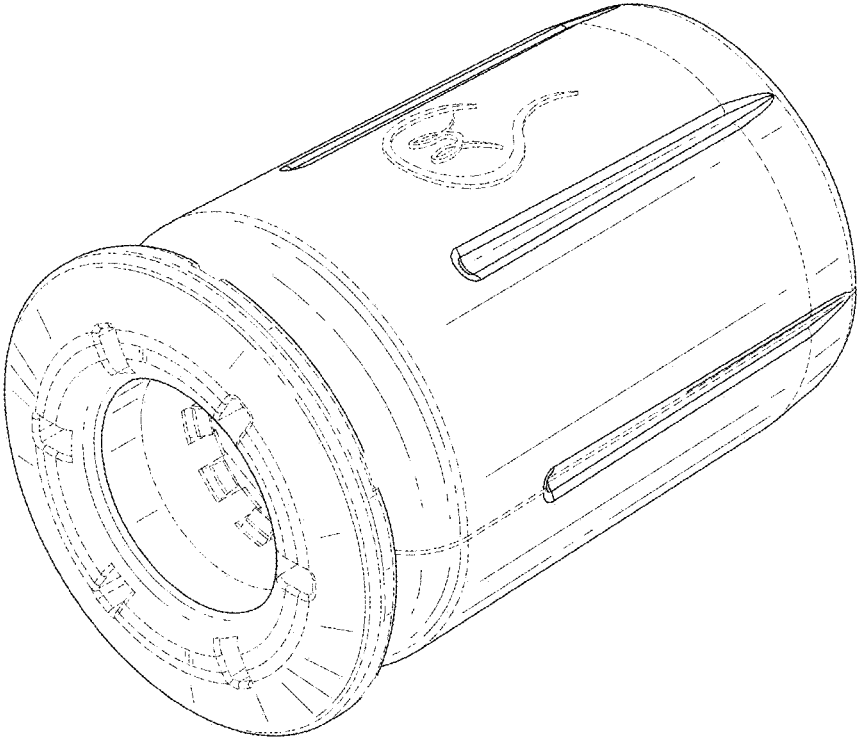

FIG. 2

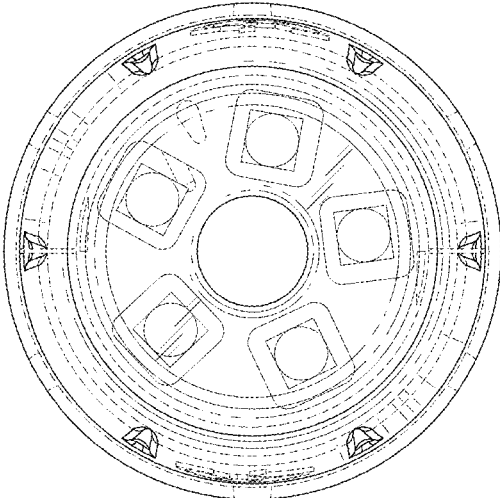

FIG. 3

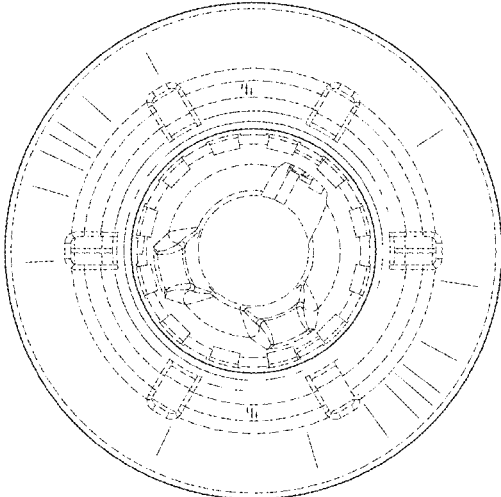

FIG. 4

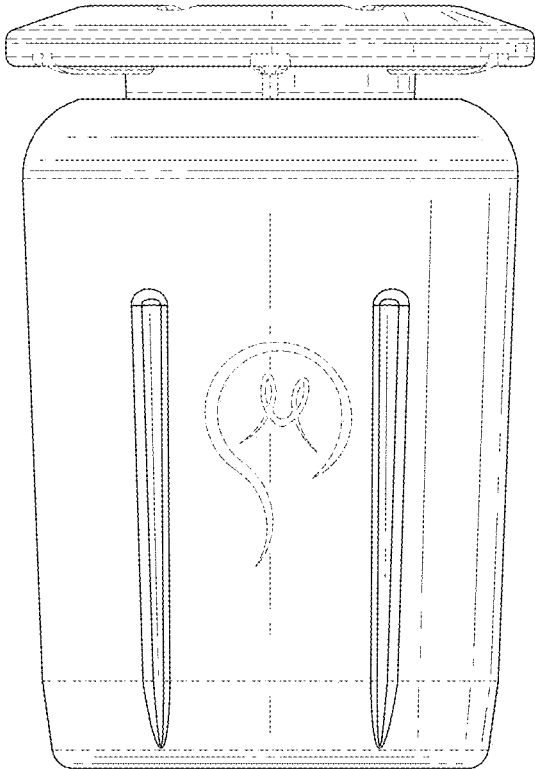

FIG. 5

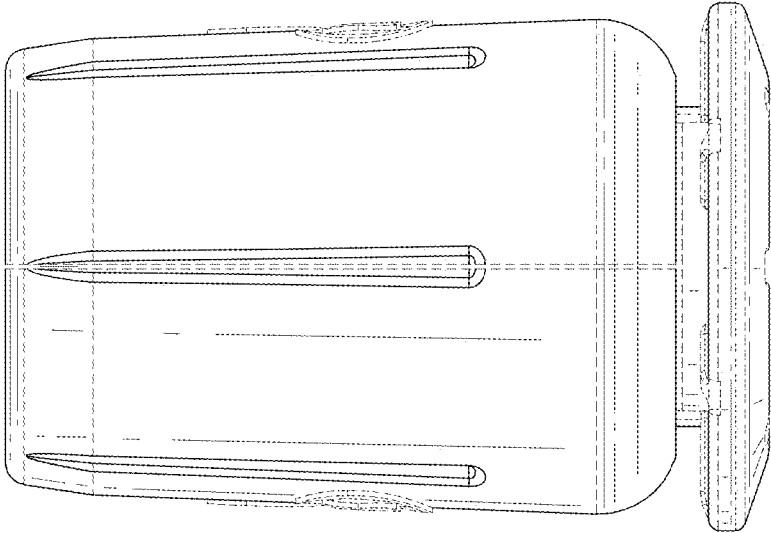

FIG. 6