



(19) **United States**

(12) **Patent Application Publication**

Lofgren et al.

(10) **Pub. No.: US 2004/0168014 A1**

(43) **Pub. Date: Aug. 26, 2004**

(54) **DEVICE AND METHOD FOR CONTROLLING SOLID-STATE MEMORY SYSTEM**

application No. 07/736,733, filed on Jul. 26, 1991, now Pat. No. 5,430,859.

Publication Classification

(76) Inventors: **Karl M. J. Lofgren**, Newport Beach, CA (US); **Jeffrey Donald Stai**, Placentia, CA (US); **Anil Gupta**, Irvine, CA (US); **Robert D. Norman**, San Jose, CA (US); **Sanjay Mehrotra**, Milpitas, CA (US)

(51) **Int. Cl.⁷** **G06F 12/00**
(52) **U.S. Cl.** **711/103**

(57) **ABSTRACT**

A memory system includes an array of solid-state memory devices are in communication with and under the control of a controller module via a device bus with very few lines. This forms an integrated-circuit mass storage system which is contemplated to replace a mass storage system such as a disk drive memory in a computer system. Command, address and data information are serialized into component strings and multiplexed before being transferred between the controller module and the array of memory devices. The serialized information are accompanied by a control signal to help sort out the multiplexed components. Each memory device in the array is assigned an array address by an array mount. An memory device is selected by an appropriate address broadcast over the device bus, without requiring the usual dedicated select signal. A reserved array mount configuration is used to unconditionally select the device mounted. A reserved address broadcast over the device bus deselected all previously selected memory devices. Read performance is enhanced by a read streaming technique in which while a current chunk of data is being serialized and shifted out of the memory subsystem to the controller module, the controller module is also setting up the address for the next chunk of data to begin to address the memory system.

Correspondence Address:

PARSONS HSUE & DE RUNTZ LLP
655 MONTGOMERY STREET
SUITE 1800
SAN FRANCISCO, CA 94111 (US)

(21) Appl. No.: **10/785,373**

(22) Filed: **Feb. 23, 2004**

Related U.S. Application Data

(60) Continuation of application No. 09/939,290, filed on Aug. 22, 2001, now Pat. No. 6,715,044, which is a continuation of application No. 09/657,369, filed on Sep. 8, 2000, now Pat. No. 6,317,812, which is a continuation of application No. 09/064,528, filed on Apr. 21, 1998, now Pat. No. 6,148,363, which is a continuation of application No. 08/931,193, filed on Sep. 16, 1997, now Pat. No. 5,806,070, which is a continuation of application No. 08/396,488, filed on Mar. 2, 1995, now abandoned, which is a division of

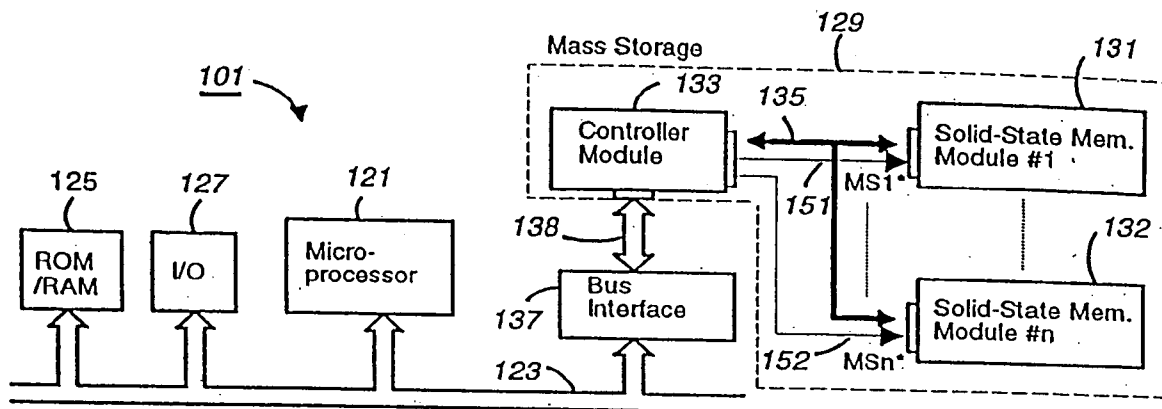

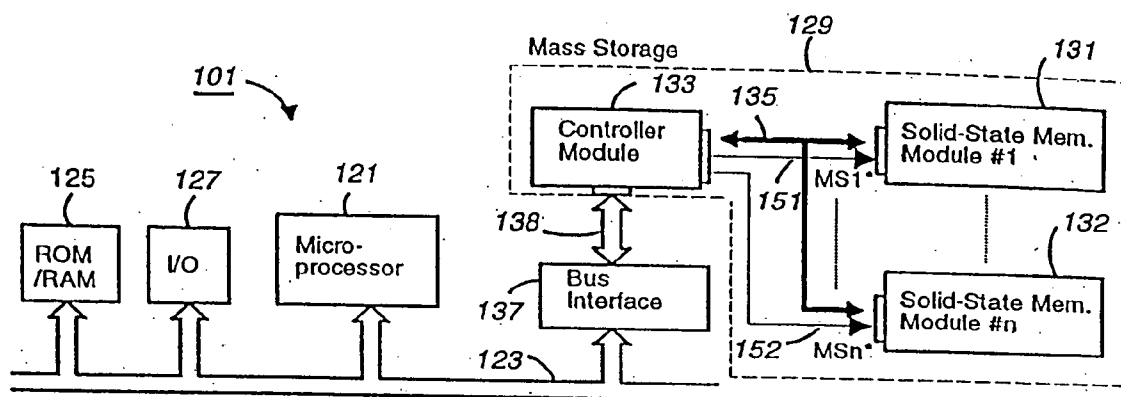

Fig. 1A

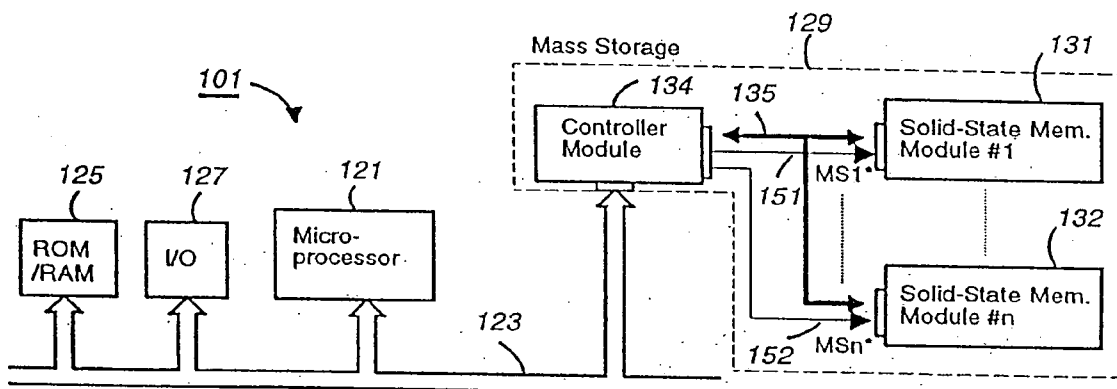

Fig. 1B

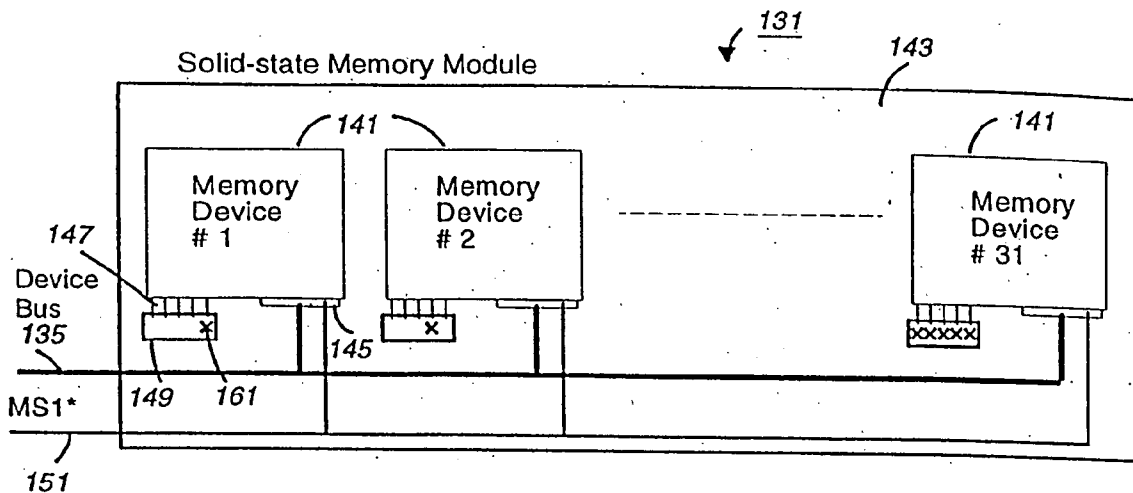

Fig. 2A

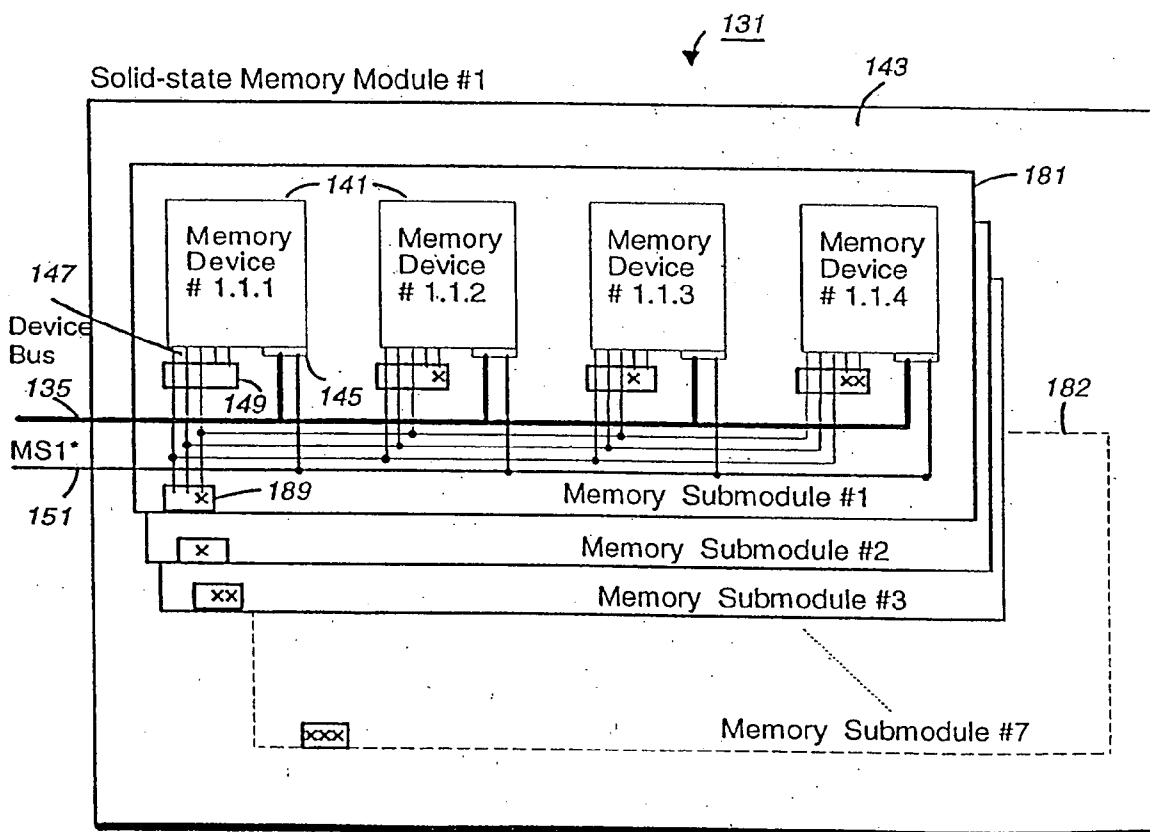

Fig. 2B

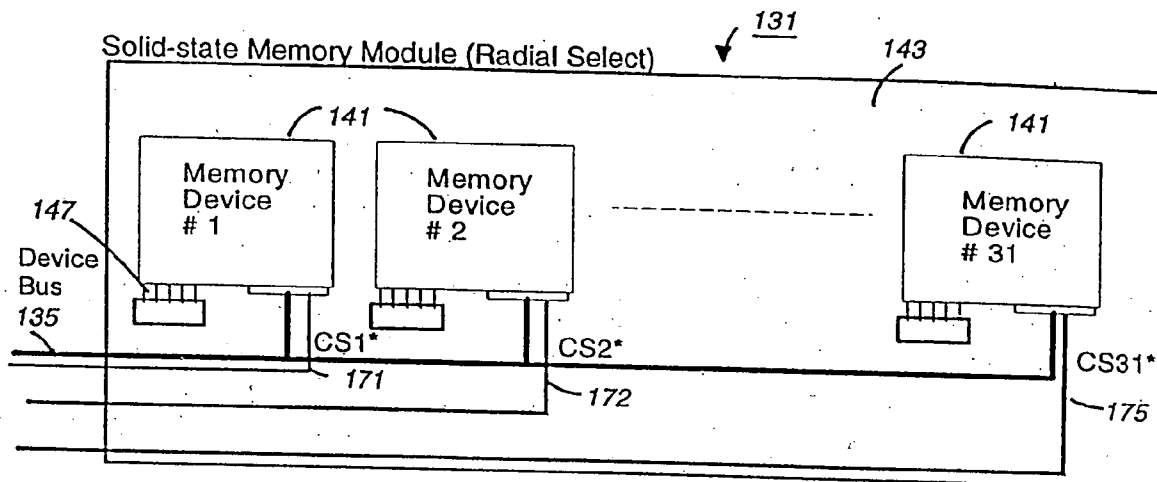

Fig. 3

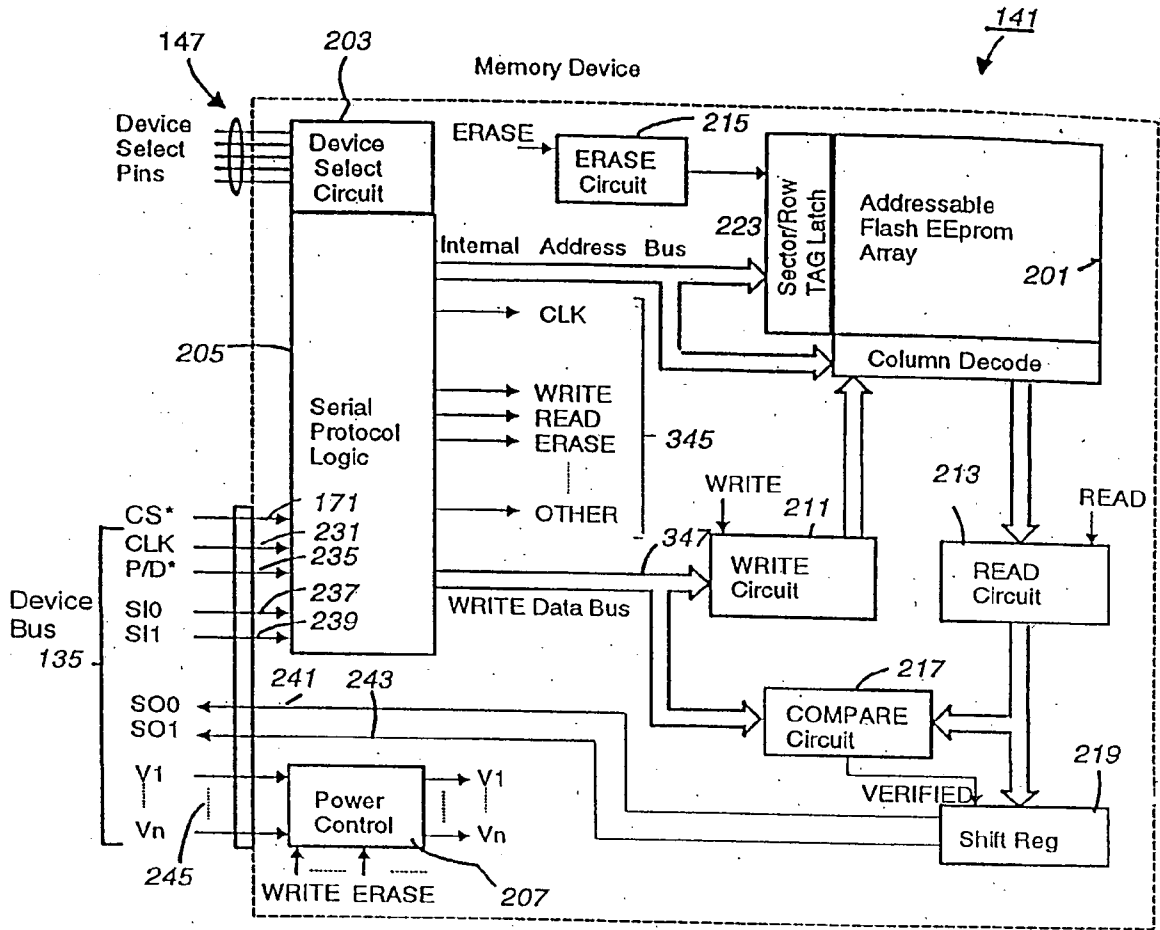

Fig. 4

Device Select Pins	Shift-in from SI0,SI1	DS (Device Select)
11111 (Master-select code)	Don't care	(selected)
11000 (example)	11000 (matched)	(selected)
11000 (example)	00001 (not matched)	(no change)
11000 (example)	11111 (Deselect code)	(deselected)

Fig. 6C

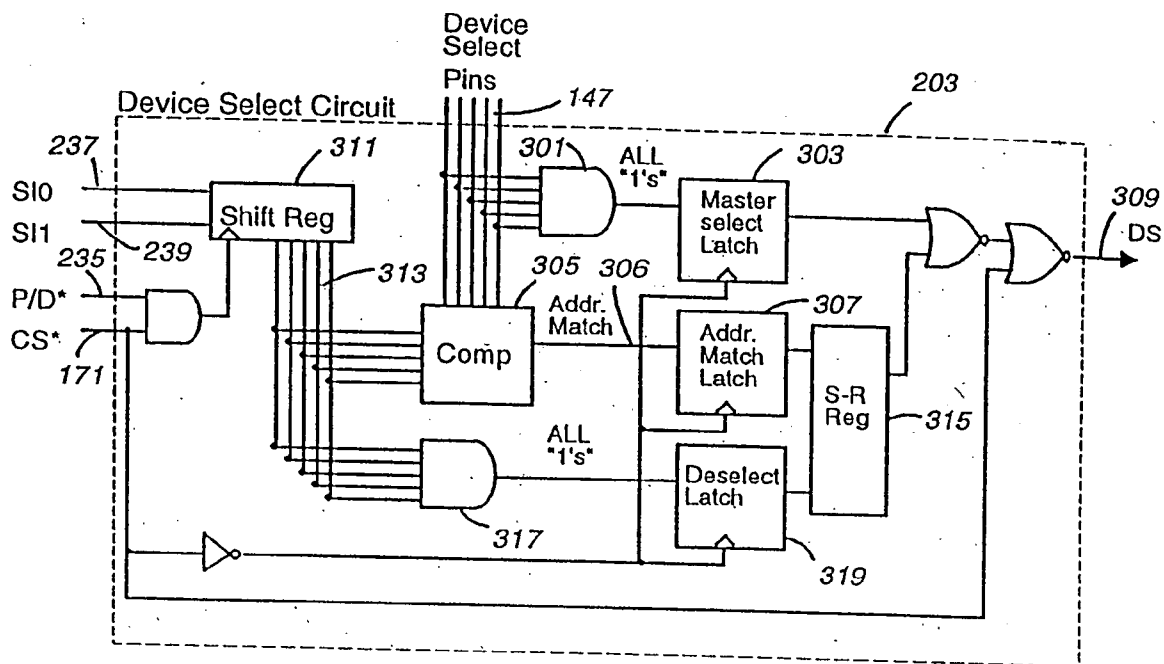

Fig. 5A

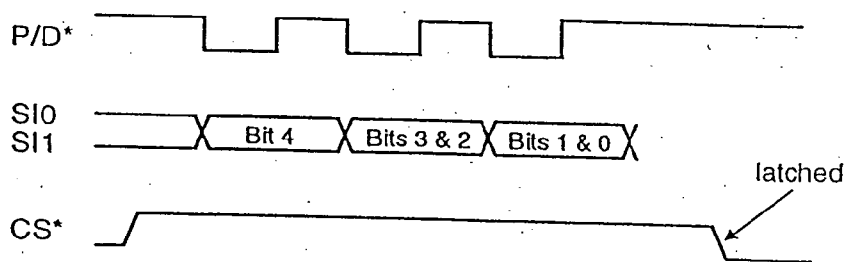

Fig. 5B

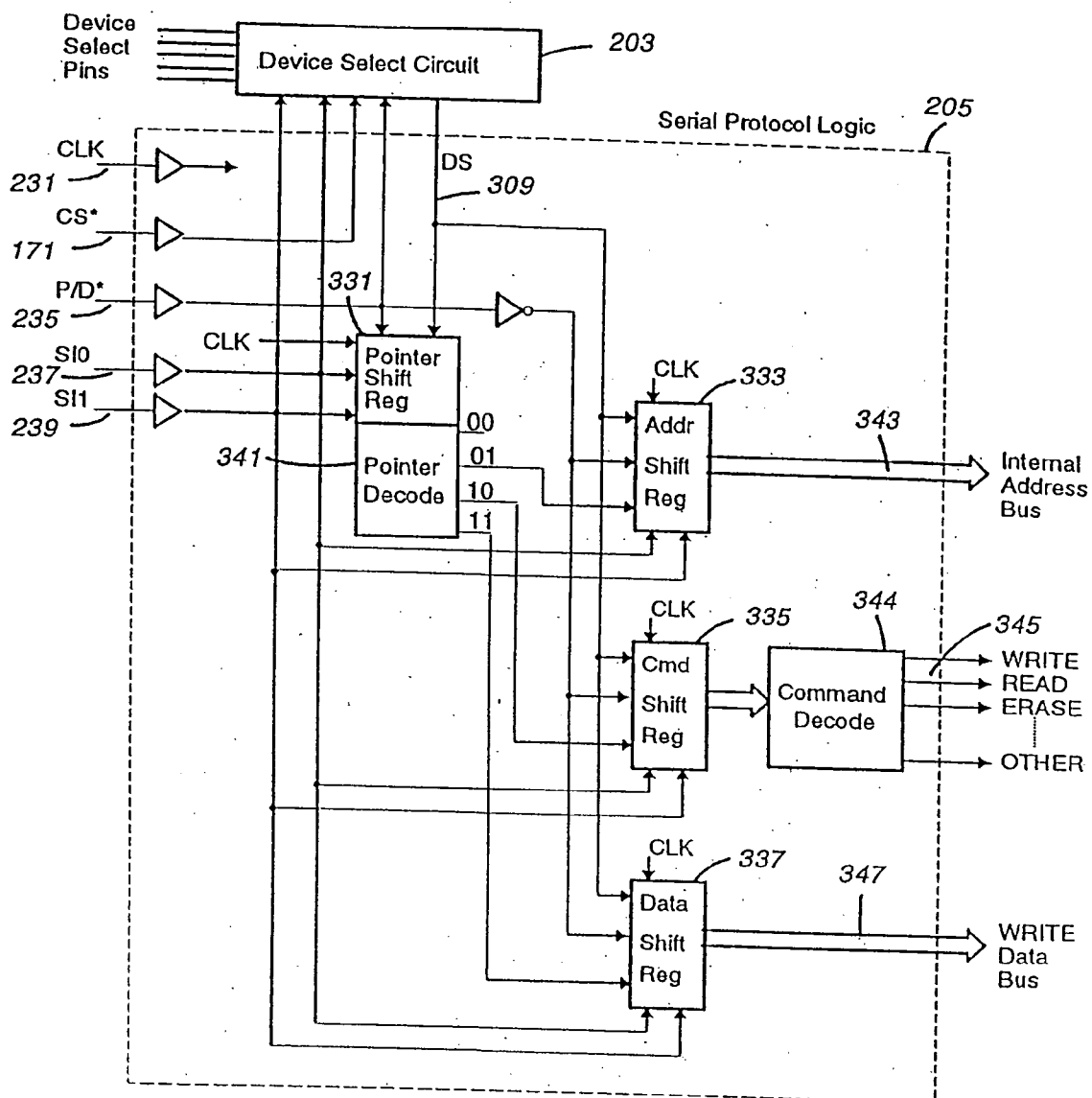

Fig. 6A

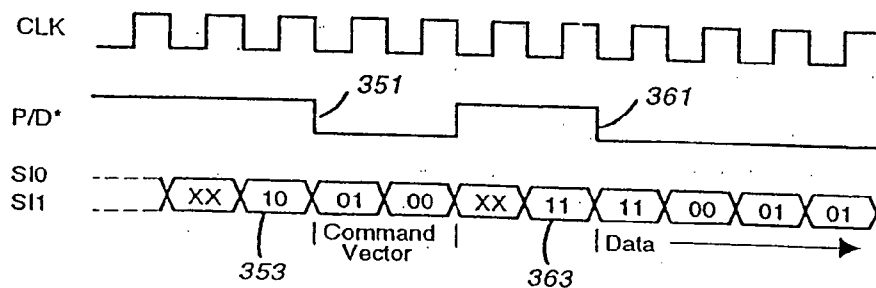

Fig. 6B

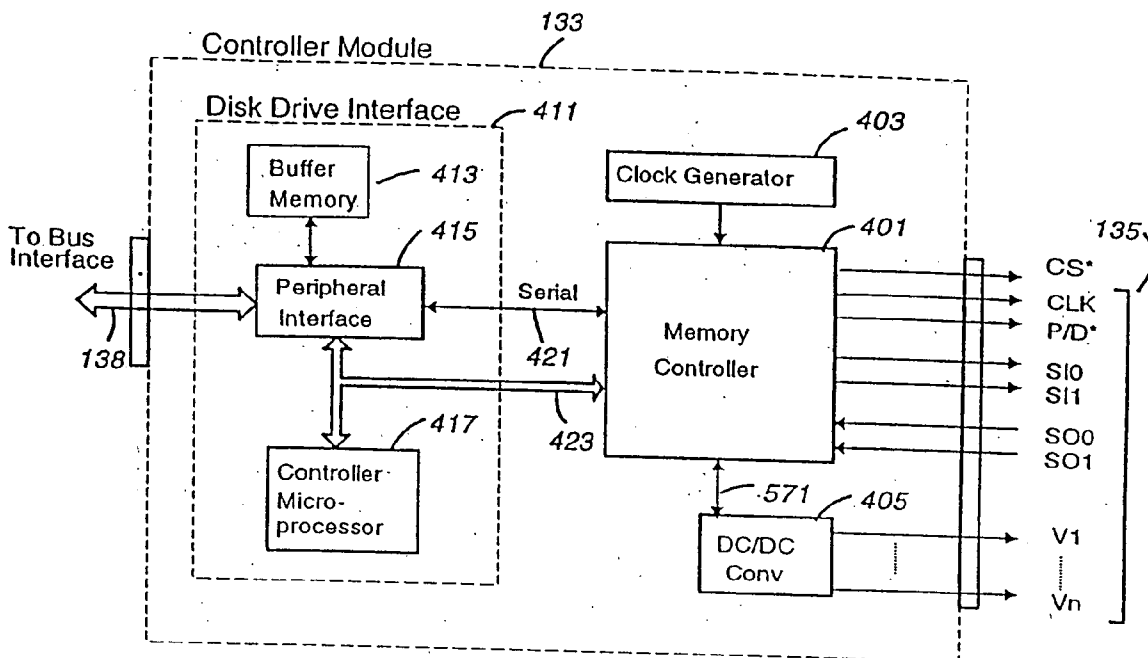

Fig. 7A

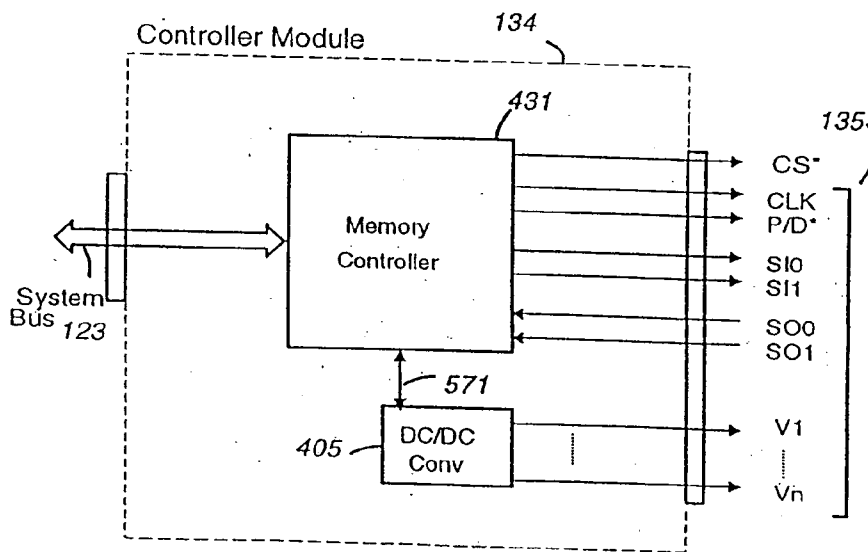

Fig. 7B

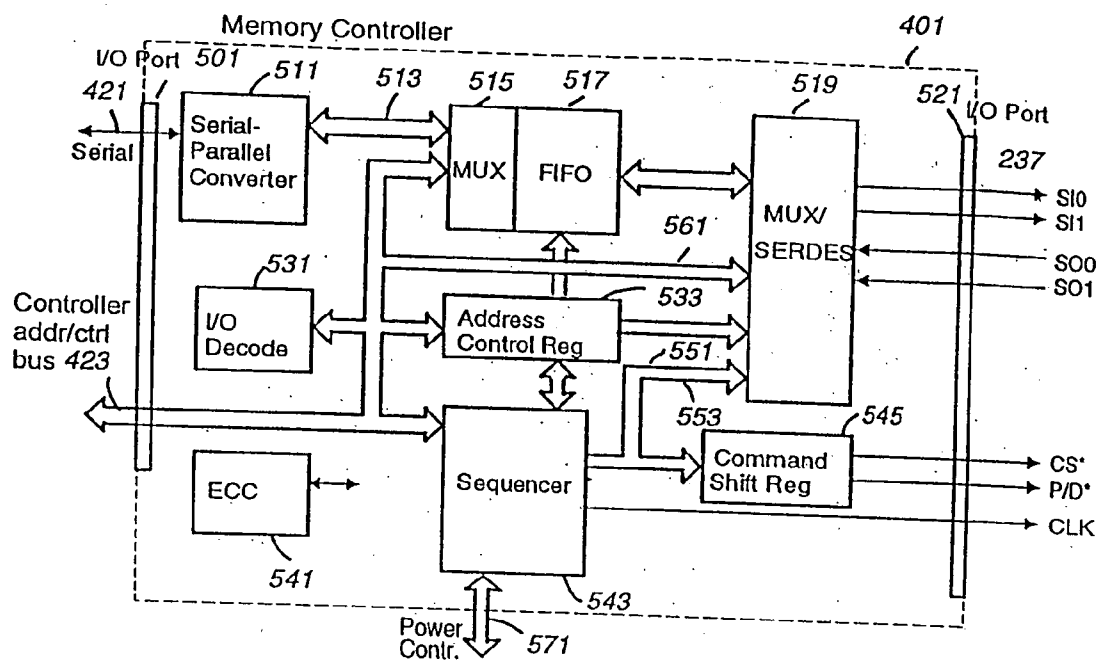

Fig. 8A

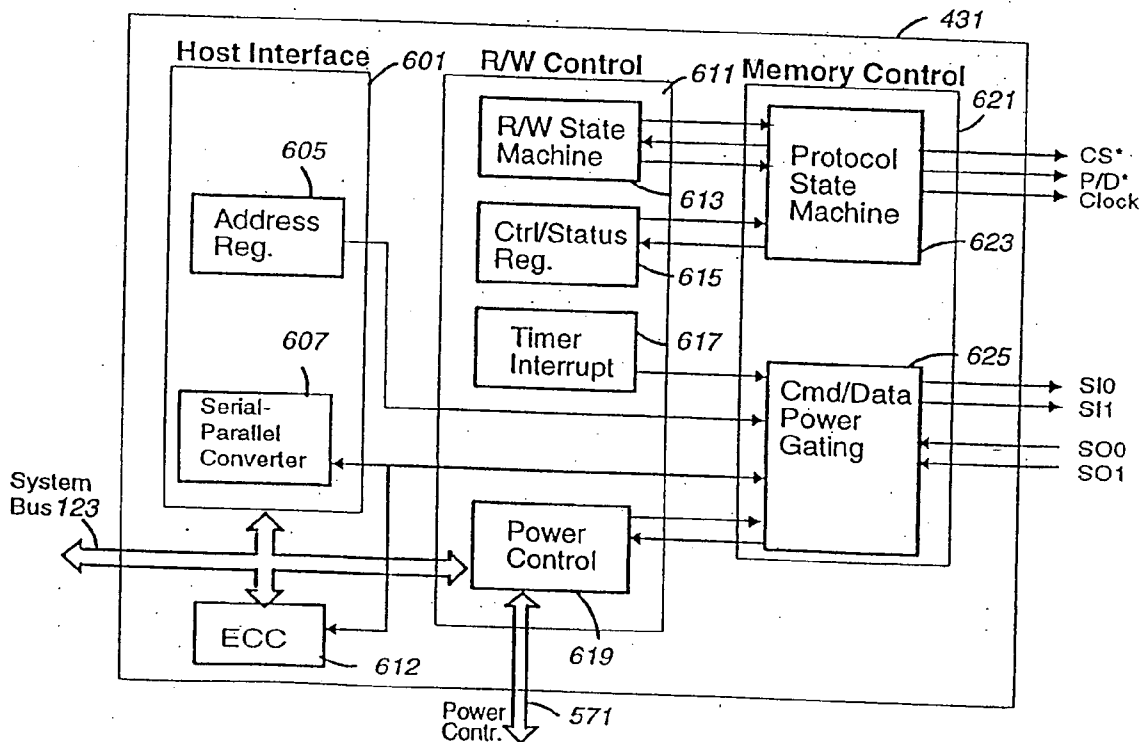

Fig. 8B

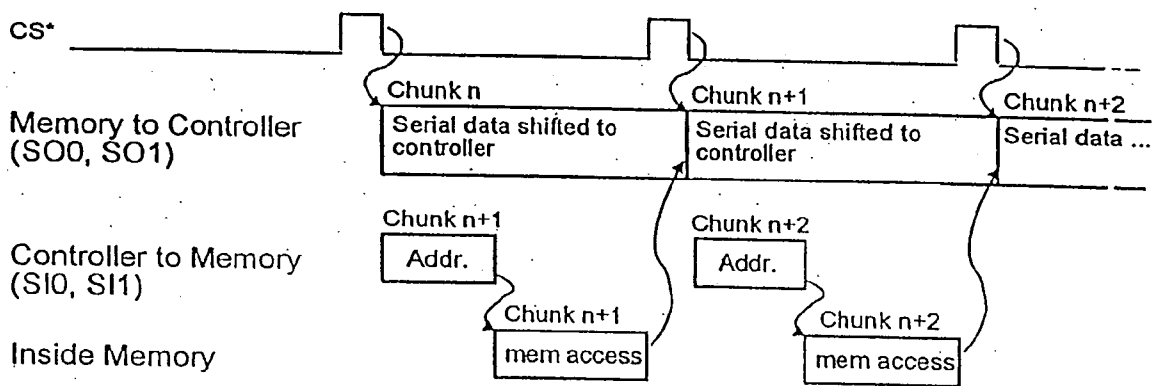

Fig. 9

DEVICE AND METHOD FOR CONTROLLING SOLID-STATE MEMORY SYSTEM

BACKGROUND OF THE INVENTION

[0001] This invention relates generally to a device and method for electronic data communication and particularly that between a memory controller and an array of memory chips.

[0002] Conventional memory system design uses a large number of parallel signals for the addressing, data transfer, and control of system operations. This is a very convenient means of configuring memory systems and results in very fast system operation. This is particularly true for integrated circuit, random access memory devices.

[0003] A disadvantage arises from this approach in that a large number of signal lines needs to be routed to each and every memory device in the memory system. This entails rather inefficient use of printed circuit board area and large cables and backplanes. Also, the system power supply must have higher capacity in order to deliver higher peak power for parallel signalling. In most cases, however, this inefficiency must be tolerated in order to achieve best possible speed of operation.

[0004] In some applications, on the other hand, it is possible to employ a serial link between two systems in order to reduce the number of cables therebetween, as well as the size of the cables, backplanes, and circuit boards in the systems. Overall, physical density can be dramatically improved over conventional methods, in that circuit boards can be made smaller and the total physical volume required for the connecting systems can be reduced. However, serial connections are usually slower than their parallel counterparts.

[0005] It is desirable to have simple connections between a memory controller and an array of memory devices, without compromising performance.

SUMMARY OF THE INVENTION

[0006] Accordingly, it is an object of the present invention to simplify the connections between two systems with minimum compromise on performance.

[0007] It is another object of the present invention to simplify the connections between a controller and an array of solid-state memory devices.

[0008] It is another object of the invention to provide means and method for selecting one or more memory devices within the memory array for communication.

[0009] It is also an object of the invention to provide means and method for de-selecting the memory devices which have previously been selected for communication.

[0010] It is yet another object of the present invention to allow the memory devices of the memory array to be configured so that they are all enabled for simultaneous communication.

[0011] It is yet another object of the present invention to improve the speed of the memory devices.

[0012] These and additional objects are accomplished by improvements in the architecture of a system comprising a

memory controller and an array of solid-state memory devices, and the circuits and techniques therein.

[0013] According to one aspect of the invention, an array of solid-state memory devices are in communication with and under the control of a controller module via a device bus with minimum lines. This forms an integrated-circuit memory system which is contemplated to replace a mass storage system such as a disk drive memory in a computer system. Command, address and data information are serialized and multiplexed before being transferred between the controller module and the memory subsystem. The serialized information are accompanied by a control signal to help sort out the multiplexed components. When the control signal is asserted, a circuit on each memory device of the subsystem interprets the serialized bits of information as a pointer code. After the control signal is de-asserted, the device routes subsequent bits of the serialized information to the appropriate command, address or data registers according to the type of information pointed to by the code.

[0014] The present invention uses a serial link to interconnect between the solid-state memory devices and the controller module. The serial link greatly reduces the number of interconnections and the number of external pads for each device, thereby reducing cost. Also expansion of the memory capacity of the system is simply achieved by a higher packing density of devices on standard printed circuit boards. It is not necessary to have a variety of circuit boards for each density, since the number of address and chip select signals does not change with capacity.

[0015] An important aspect of the invention is to employ a broadcast-select scheme to select or enable a given memory device chip among an array of chips in a memory board or memory module. Each memory device chip has a multi-bit set of pinouts that is connected internally to a device select circuit and externally to a multi-bit mount on the memory module's backplane. Each multi-bit mount on the backplane is pre-configured or keyed to a given address (represented by a multi-bit combination of "O"'s and "I"'s) according to its location in the array. In one embodiment, the terminals in the multi-bit mount corresponding to the "O" bit are set to ground potential. When a memory chip is powered on, the address of the array as defined by the mount key is passed onto the device select circuit of the chip. To select a given memory chip, the correct array address for that chip is sent to all the chips in the array via the interconnecting serial bus. This address is compared at each chip with that it acquired from its mount, and the chip that matched is selected or enabled by its device select circuit. A memory chip remains selected until explicitly deselected, allowing more than one memory chip to be enabled at a time.

[0016] The invention provides a simple scheme for assigning an array address to each of the chips mounted on a memory module's backplane. By providing the keying at the backplane instead of at the memory chips, the memory chips can be made generic. This also avoids the need for conventional use of individual chip select to each memory chip. This results in very low pin count in multi-chip modules, especially that of socketed modules, enabling high density package of memory chips on memory modules.

[0017] According to another aspect of the invention, the array of memory chips may be distributed over a plurality of

memory modules. Each of the memory modules can be enabled by a module select signal from the controller module.

[0018] According to another aspect of the invention, each memory module may be further partitioned into a plurality of memory submodules. These submodules may be mounted on a memory module's backplane and are all enabled by the same module select signal. The multi-bit address in the multi-bit mount for each memory device is partitioned into two subsets. The permutations of one subset are used to provide the different memory-device addresses on a memory submodule. The permutations of the other subset are used to provide the different memory-submodule addresses on a memory module. Thus, there is a pre-configured multi-bit mount for each memory submodule on the memory module's backplane.

[0019] According to another aspect of the invention, one particular key among the permutations of the multi-bit mounts is reserved as a "master key" to unconditionally have each device select circuit enable its chip. In the preferred embodiment, this "master key" is given by having all the bits of a multi-bit mount not grounded. This allows a group of chips with this "master key" mount to be selected together.

[0020] According to yet another aspect of the invention, the broadcast select scheme has a reserved code that can be communicated to the array of memory chips on the backplane in order to deselect all previously selected chips. In the preferred embodiment, a select sequence of shifting in a pattern of all ones results in a global deselect.

[0021] Another important aspect of the invention is to implement a streaming read scheme to improve the read access of the memory system. While a chunk (e.g. 64 bits) of data is being read from the memory cells, serialized and shifted out of a memory chip, the address for the next chunk is being setup and sent to the memory chip to begin accessing the next chunk of data. The overlapping operations of reading out of one chunk of data and staging for the access of the next chunk of data greatly improve the read access speed of the memory system.

[0022] As mentioned before, the use of a serial link is unconventional for integrated circuit memory chips. These memory devices are typically random-access memories which are designed for high speed access and therefore employ parallel address and data buses. Serializing the command, address and data information for these devices is unconventional since it may require more circuitry than conventional parallel access, and may result in slower access. However, the present invention, when used in a block transfer regime (e.g., reading 4096 consecutive user bits at a time, is relatively insensitive to access time, the speed being determined largely by the data throughput once reading has begun. The present invention recognizes that employment of a serial link in the present EEPROM system architecture, particularly with the features of broadcast selection and streaming read, results in simplified connections therein without compromising access speed for the intended application.

[0023] Additional objects, features and advantages of the present invention will be understood from the following description of the preferred embodiments, which description should be taken in conjunction with the accompanying drawings.

BRIEF DESCRIPTION OF THE DRAWINGS

[0024] FIG. 1A is a general microprocessor system connecting via a bus interface to a solid-state mass storage system according to a preferred embodiment of the present invention;

[0025] FIG. 1B is a general microprocessor system connecting directly via a system bus to a solid-state mass storage system according to another preferred embodiment of the present invention;

[0026] FIG. 2A illustrates schematically the solid-state memory module having an array of memory devices mounted on "keyed" mounts in a memory board backplane;

[0027] FIG. 2B illustrates schematically another memory partition in which a plurality of memory submodules are being mounted on "keyed" mounts on the backplane of the solid-state memory module, and a plurality of memory devices is being mounted on "keyed" mounts on each memory submodule;

[0028] FIG. 3 illustrates a "radial select" configuration of the memory devices in FIG. 2 in which the mounts all have the master, all-bits-ungrounded "keys", and each memory device is selected by an individual chip select (CS*) signal;

[0029] FIG. 4 is a schematic illustration of the functional blocks of a flash EEPROM memory device;

[0030] FIG. 5A shows one embodiment of the device select circuit in FIG. 4;

[0031] FIG. 5B is a timing diagram for the device select circuit of FIG. 5A;

[0032] FIG. 6A is one embodiment of the serial protocol logic within the memory device illustrated in FIG. 4;

[0033] FIG. 6B is a timing diagram for the serial protocol logic of FIG. 6A;

[0034] FIG. 7A is a schematic illustration of the functional blocks of the controller module illustrated in FIG. 1A;

[0035] FIG. 7B is a schematic illustration of the functional blocks of the alternative controller module illustrated in FIG. 1B;

[0036] FIG. 8A is a schematic illustration of the functional blocks of the memory controller illustrated in FIG. 7A;

[0037] FIG. 8B is a schematic illustration of the functional blocks of the memory controller illustrated in FIG. 7B; and

[0038] FIG. 9 is a timing diagram for the read streaming scheme, according to a preferred embodiment of the present invention.

[0039] Table 1 shows the logic of the device select circuit in FIGS. 4-6.

DETAILED DESCRIPTION OF THE PREFERRED EMBODIMENTS

[0040] A typical computer system in which the various aspects of the present invention are incorporated is illustrated generally in FIG. 1A. A typical computer system 101 has an architecture that includes a micro-processor 121 connected to a system bus 123, along with random access,

main system memory **125**, and at least one or more input-output devices **127**, such as a keyboard, monitor, modem and the like. Another main computer system component that is connected to a typical computer system bus **123** is a large amount of long-term, non-volatile memory **129**. Conventionally, such a mass storage is a disk drive with a capacity of tens of megabytes of data storage. During the functioning of the computer system **101**, data from this mass storage **129** is retrieved into the system volatile memory **125** for processing, and new or updated data can be easily written back to the mass storage.

[0041] One aspect of the present invention is the substitution of a specific type of semiconductor memory system for the disk drive but without having to sacrifice non-volatility, ease of erasing and rewriting data into the memory, speed of access, and reliability. This is accomplished by employing an array of non-volatile, solid-state memory, integrated circuit chips. This type of memory has additional advantages of requiring less power to operate, and of being lighter in weight than a hard disk drive memory, thereby being especially suited for battery-operated portable computers.

[0042] The integrated circuit mass storage memory **129** includes one or more solid-state memory modules such as **131**, **132** under the control of a controller module **133**. Addresses, data, and commands are communicated between the memory modules **131**, **132** and the controller module **133** by means of a device bus **135**. The one or more memory modules such as **131**, **132** can be selectively enabled by individual module select signals such as $MS1^*$, $MS2^*$. These signals are carried in select lines such as **151**, **152** from the controller module to individual memory modules. The controller module **135** is connected to a bus interface **137** via an interface bus **138**. The interface **137** is connected on the other hand to the computer system via the standard computer system bus **123**. For personal computer systems the bus interface **137** is preferably an IDE (Integrated Device Electronics) controller.

[0043] FIG. 1B illustrates an alternative embodiment in which the controller module **134** is connected directly to the system bus **123** of the computer system **101**. In this embodiment, as will be described later, the controller module **134** is simplified as some of its functions are performed by the system microprocessor **121** and other system resources.

[0044] Solid-State Memory Module

[0045] FIG. 2A illustrates schematically the solid-state memory module such as **131** or **132** of FIGS. 1A and 1B having an array of memory devices **141** mounted on a printed circuit memory board or a backplane **143**. Each memory device **141** is an integrated circuit memory chip.

[0046] Each memory device **141** has two groups of external pads or pinouts. The first group is the device-bus pinouts **145** for connection to the device bus **135** on the backplane **143**. In this way, the device bus **135** interconnects between all the memory devices **141** in the solid-state memory module **131** on the one hand, and the controller module **133** or **134** on the other hand (see FIGS. 1 and 2).

[0047] The second group of external pads are device-select pinouts **147** which are to be connected to corresponding pads of a mount **149** on the backplane **143**. There is one

such mount for each memory device so that the memory devices **141** are laid out in an array in the backplane **143**.

[0048] As an example, a memory device **141** may have five device-select pinouts, which are connected to five corresponding pads on the mount **149**. By selectively grounding certain pads, such as a pad **161** on the mount, each mount may be configured or "keyed" to designate a definite address of the array. With five pins, the number of groundable pad configurations or "keys" amounts to $2^5=32$ permutations. Thus in the preferred embodiment, the mounts in the array will have grounding configurations (11111), (11110), (11101), . . . , (00000), where "O" denote a pad that is grounded.

[0049] As will be discussed in connection with a device select circuit illustrated in FIGS. 4 and 5A, these keyed mounts are used to assign an array address to the memory device chip **141** mounted thereon. In this way each memory device chip can be addressed for selection or enablement.

[0050] FIG. 2B illustrates schematically another memory partition in which each memory module such as **131** may be further partitioned into a plurality of memory submodules such as **181**, **182**. This allows for more flexibility in memory configurations without the need to provide at the outset the full capacity of mounts for all possible memory devices **141** in the memory module's backplane **143**. In this way, the backplane **143** needs only provide a reduced set of mounts and spaces for these submodules. Each submodule such as **181**, **182** has a smaller group of memory devices **141** mounted on it and they are all enabled by the same module select signal $MS1^*$ **151**.

[0051] Similar to the case illustrated in FIG. 2A, each memory device **141** is given an address on the memory submodule **181** by means of the grounding configuration of the multi-pin mount **149**. However, with a reduced number the memory devices in a submodule, only a subset of the bits of the multi-pin mount is required. For example, with four memory devices **141** per submodule, only two bits of the multi-pin mount **149** need be configured to provide unique addresses on each submodule. The rest of the bits in the multi-pin mount **149** may be configured to provide unique addresses for the memory submodules such as **181**, **182** on the backplane **143** of the memory module **131**. For a 5-bit mount, two of the bits are configured for four memory-device addresses on each memory submodule, and the other three bits are configured for up to eight memory-submodule addresses on the memory module's backplane **143**.

[0052] The memory submodules such as **181**, **182** are each mounted on the memory module's backplane **143** with connections to the device bus **135** and to a submodule multi-pin mount **189**. This mount **189** is a subset of a memory-device's multi-pin mount **149**. For the example above, it will be a 3-pin mount.

[0053] According to another aspect of the invention, one particular "key" among the permutations of grounding configurations of the multi-bit mounts **149** is reserved as a "master select" which unconditionally allows each chip to be selected or enabled.

[0054] FIG. 3 illustrates a radial select scheme, in which all the memory devices **141** in the solid-state memory module **131** can be enabled for selection by a "master-select" configuration. In the preferred embodiment, this

“master select” is given by having all the bits of the mount not grounded. Thus, each mount **149** in the array has the same grounding configuration, namely (11111). Individual memory device within the solidstate memory module **131** is selected by dedicated chip select signals such as CS1*, CS2*, CS31* as in the conventional case. These dedicated chip select signals are respectively carried in additional lines such as **171**, **172**, **175** among the device bus **135**.

[0055] Flash EEPROM Memory Device

[0056] Examples of non-volatile, solid-state memory, integrated circuit chips include read-only-memory (ROM), electrically-programmable-read-only-memory (EPROM), electrically-erasable-programmable-read-only-memory (EEPROM), and flash EEPROM.

[0057] In the preferred embodiment, an array of flash electrically-erasable-programmable-read-only memories (EEPROM's) in the form of an integrated circuit chip is employed as the memory device **141**. A flash EEPROM device is a non-volatile memory array which may be partitioned into one or more sectors. These sectors are addressable for wholesale electrical erasing of memory cells therein. Various details of flash EEPROM cells and systems incorporating defect managements have been disclosed in two co-pending U.S. patent applications. They are copending U.S. patent applications Ser. No. 508,273, filed Apr. 11, 1990, by Mehrotra et al., and Ser. No. 337,566, filed Apr. 13, 1989, by Harari et al. Relevant portions of these two disclosures are hereby incorporated by reference.

[0058] **FIG. 4** is a schematic illustration of the functional blocks of a flash EEPROM memory device. The flash EEPROM memory device **141** includes an addressable flash EEPROM cell array **201**, a serial protocol logic **205**, a power control circuit **207**, and various WRITE, READ, ERASE circuits **211**, **213**, **215**, **217** and **219**.

[0059] Serial Device Bus

[0060] One important feature of the present invention is to employ a serial link between each of the memory devices **141** and the controller module **133** or **134**. The serial link carries serialized addresses, data and commands. This has several advantages in the present application. The serial link greatly reduces the number of interconnecting lines between the controller module **133** or **134** and each of the memory device chip **141**. Fewer signal lines requires fewer traces on the printed circuit memory boards or backplanes **143**, resulting in dramatic savings in board space and overall system density improvements. Fewer pins are required. This applies both to memory card edge connectors and to individual memory device chip pinouts. The results of fewer pins is lower costs and greater system reliability. Also fewer pinouts on a memory device results in a smaller device and consequently, lower device cost. Finally, expanding the memory capacity of the system is simply achieved by a higher packing density of devices on standard printed circuit boards. It is not necessary to have a variety of circuit boards for each density, since the number of address and chip select signals does not change with capacity when employing a serial link. By having a common serial interface, a controller can be designed to support memory devices of differing capacities without modifications to the system. In this way, future memory devices of different capacities can be connected to the same controller without hardware changes

resulting in forward and backward compatibility between memory cards and controllers.

[0061] Still referring to **FIG. 4**, the flash EEPROM memory device **141** has two sets of external pins. The first set of external pins is for connection to the device bus **135**. The device bus **135** includes a timing signal line, CLK **231**, a control signal line P/D* **235**, two serial-In's, SI**0237**, SI**1239**, two serial-Out's S**00241**, SO**1243**, and a set of power lines V1 . . . Vn **245**. Another control signal line, chip select CS* **171** is shown outside the device bus **135**, although in some embodiments, it may be regarded as part of the device bus **135**. The use of two serial-In's and two serial-Out's requires very few signal lines and yet still allow information to be transferred at adequate rates.

[0062] The second group of external pins consists of the five device-select pinouts **147** described in connection with **FIGS. 2 and 3**.

[0063] Device Select Scheme and Circuit

[0064] According to the present invention, any memory device **141** among the array of memory devices mounted on the backplane **143** may be enabled such that the device is selected whenever the CS* **171** (chip select) is asserted. In particular, each device may be enabled in one of two ways.

[0065] The first is “master-select” by means of a special grounding configuration of the device select pins **147**, as described earlier in connection with **FIG. 3**. One particular “key” among the permutations of grounding configurations of the multi-bit mounts **149** (see **FIG. 3**) is reserved as a “master select” which unconditionally allows each chip to be selected or enabled. This allows a group of chips with this “master select” mount to be selected together (see **FIG. 3A**) or allows for radial selection of individual devices (see **FIG. 3B**).

[0066] The second is “address-select” by shifting in an address that matches the one defined by the device select pins **147** from the serial lines SIO **237**, SI**1239**. As described in connection with **FIGS. 2 and 3**, the address for each location in the array is defined by the grounding configuration or “key” of the mount **149** thereat. By virtue of the memory device connecting to the mount **149**, the address defined by the mount is passed onto the memory device **141**. Whenever a memory device **141** is to be selected, its array address is made available on the device bus **135**. A device select circuit in each memory device **141** compares the array address obtained from the device bus to that obtained from the device select pinouts **147**.

[0067] According to yet another aspect of the invention, an “address-deselect” scheme is employed in which a special address or code can be shifted in to deselect devices that have previously been selected. In the preferred embodiment, the special deselect code is (11111).

[0068] Table 1 summarizes the logic of the device select circuit **203** which appears in **FIGS. 4-6**. The device select circuit has inputs from the device select pins **147** and the device bus **135**, and has an output DS **309** (see **FIG. 5A**) to select or deselect the device it is controlling.

[0069] **FIG. 5A** shows one embodiment of the device select circuit **203** incorporating the “master-select”, “address-select”, “address-deselect” features. The circuit **203** has inputs SI**0237**, SI**1239**, and the two control lines

CS* 171, P/D* 235 from the device bus 135. In the present example, the array address of the memory device 141 in FIG. 4 is defined by a 5-bit address. This 5-bit address is set by the mount 149 and communicated to the device select circuit 203 via the device select pinouts 147.

[0070] The master-select feature is implemented by the 5-input AND gate 301. When a pin configuration of (11111) appears, the HIGH output of the AND gate 301 is latched by a master-select latch 303. This in turn results in DS 309 becoming HIGH.

[0071] Device selection by address-matching is implemented by a comparator 305 and an address-match latch 307. In order to enable a particular memory device 141, the same address for that device must be obtained from the serial-in lines 237, 239 of the device bus 135. In the present embodiment, a 5-bit array address is shifted into a shift register 311 from the serial-in lines SI0237, SI1239. The clocking signal is carried in the control line P/D* 235 which is gate-enabled by a HIGH signal in the master chip select line CS* 171. The 5-bit array address is then passed from the shift register 311 via the bus 313 to the comparator 305. The comparator 305 compares this address with that obtained from the device-select pinouts 147. The comparator output 306 goes HIGH whenever the addresses match. This output is clocked into the address-match register 307 by the falling edge of CS* 171. This results in a S-R register 315 being set HIGH such that DS 309 is also HIGH and the device is selected. On the other hand, when the addresses do not match, DS 309 will be LOW and the device is not selected.

[0072] Device deselection by "address-deselect" is implemented by a special deselect code e.g., (11111) is used to signal global deselection. A second 5-input AND gate 317 looks for a data pattern of all one's being shifted into the shift register 311. When a match occurs and also the chip select CS* in the line 171 is activated, the comparator 317 outputs a deselect signal which is latched by a deselect latch 319. This in turn is used to reset the S-R register 315 on all devices previously selected. By shifting in the (11111) pattern and activating, the CS* signal, all devices that are presently selected will see the deselect pattern and will be deselected.

[0073] FIG. 5B is a timing diagram for the device select circuit of FIG. 5A. First, the CS* signal goes high and the timing signal in P/D* at half the CLK rate is used to clock the serial address from SI0 and SI1 into the shift register 301. After three P/D* clock periods, 6 bits have been loaded into the shift register 301 and only the least significant 5 bits are used by the comparator 303. The trailing edge of CS* is used to load the various latches 303, 307, 319.

[0074] Serial Protocol and Device

[0075] After a memory device 141 (see FIGS. 2, 3, 4) has been addressed and enabled, read or write operations may be performed on it. A stream of serialized addresses, data and commands is then passed between the controller module 133 or 134 (see FIGS. 1A and 1B) and the enabled memory device 141 via the device bus 135. From the memory device end, a serial protocol logic is used to sort out, re-organize and re-route the various information in the serial stream to their appropriate destinations.

[0076] FIG. 6A is one embodiment of the serial protocol logic in the memory device 141 illustrated in FIG. 4. The

serial protocol logic 205 receives inputs from the device bus 135. They are clock signals from the CLK 231 line, control signals from CS* 171, P/D* 235 and serial-in lines SI0237, SI1239. The serial protocol logic 205 essentially sorts out the serialized stream of addresses, data and commands from the serial lines SI0237 and SI1239. It then re-routes each type of information before converting some of them into parallel forms for output.

[0077] A pointer shift register 331 and a pointer decode 341 are used to direct the non-pointer information in the serial lines SI0237, SI1239 to either an address shift register 333 or to a command shift register 335 or to a data shift register 337.

[0078] In the preferred embodiment, the address shift register 333, when enabled, shifts the 2-bit stream from the serial lines SI0, SI1 out to an 18-bit internal address bus 343. Similarly, the command shift register 335 shifts out a parallel command vector which is further decoded by a command decode 344 into a number of control signals such as WRITE, READ, ERASE, . . . , and OTHER carried by control lines 345. Similarly, the data shift register 337 shifts in a 64-bit chunk of data, and outputs it in parallel on a WRITE data bus 347.

[0079] The pointer shift register 331 is first enabled to receive the routing information. After the routing information is received, the pointer shift register 331 is disabled. The routing information received is decoded by the pointer decode 341 to selectively enable one of the three shift registers 333, 335, 337. Timing and control is provided by the P/D* line 235. One state (HIGH) of P/D* 235 is used to enable the pointer shift register 331 and disable the shift registers 333, 335 and 337. The other state (LOW) of P/D* 235 is used to disable the pointer shift register 331 and enable the shift registers 333, 335 and 337.

[0080] The operation of the serial protocol logic 205 illustrated in FIG. 6A is best understood with reference to its timing diagrams.

[0081] FIG. 6B is the corresponding timing diagrams for the operations of the serial protocol logic. When P/D* 235 is HIGH, the shift registers 333, 335 and 337 are disabled. A stream of 2-bit codes from the two serial lines SI0, SI1 are clocked into the pointer shift register 331 at the rising edge of each clock period. Each of these 2-bit codes is used to select and point to one of the shift registers 333, 335 and 337.

[0082] For example, as shown in FIG. 6A, the 2-bit code "00" is reserved for future use. Code "01" points to the address shift register 333. Code "10" points to the command shift register 335. Code "11" points to the data shift register 337. The protocol is such that when P/D* 235 goes LOW, the falling edge is used to load the last 2-bit code in the pointer shift register 331 to the pointer decode 341. In FIG. 6B, for the P/D* signal, the first falling edge shown (351) loads the code "10" (353) from the pointer shift register 331 to the pointer decode 341. This means the command shift register 335 is pointed to and is selected.

[0083] After P/D* line 235 goes LOW, the pointer shift register is disabled and the information from the serial lines SI0, SI1 are shifted into the enabled command shift register 335 and interpreted as a command vector. The shifting ends when the P/D* line 235 goes HIGH again.

[0084] Thereafter, the pointer shift register 331 is again enabled to receive information from the serial lines S10, S11. In the example shown in FIG. 6B, for the P/D* signal, the second falling edge shown (361) latches the code "11" (363) into the pointer shift register 331. This means the data shift register 337 is now pointed to and is selected. Once again, the pointer shift register 331 is disabled and the information from the serial lines S10, S11 are now shifted into the enabled data shift register 337 and interpreted as data. The shifting ends when the P/D* line 235 goes HIGH again.

[0085] Controller Module

[0086] Referring again to FIGS. 1A and 1B, having described the solid-state memory module 131 with respect to the serially linked device bus 135, attention is now directed to the controller module 133 or 134.

[0087] FIG. 7A is a schematic illustration of the functional blocks of the controller module illustrated in FIG. 1A. The controller module 133 contains essentially a memory controller 401 which manages the information flow between the solid-state memory module 131 and the disk drive interface 411. It also sequences various control signals for the operation of the memory devices 141. The memory controller 401 receives timing clock signals from a clock generator 403. It also controls the output of various voltages required for the operations of the memory device 141 by means of a power supply or converter 405. The device bus 135 links the memory controller 401 and the power supply 405 to the memory device 141.

[0088] In the preferred embodiment, a standard disk drive interface 411 is implemented between the memory controller 401 and the computer system bus 123. In this way, to the computer system 101, the controller module 133 and therefore the mass storage 129 behaves as if it is a disk drive system. This allows hardware and software compatibility when the present solid-state memory system is used to substitute for a disk drive system.

[0089] The standard disk drive interface 411 typically includes a buffer memory 413, a peripheral interface 415 and a controller microprocessor 417. The buffer memory 413 is essentially a static RAM, and it temporarily holds data that is to be written or that has just been read. The peripheral interface 415 may be implemented by a commercially available integrated-circuit chip such as the SH 265 Disk controller by Cirrus Logic Inc. The peripheral interface 415 exchanges data with the memory controller 401 via a data serial line 421. The controller microprocessor 417 may be implemented by a commercially available integrated-circuit chip such as the 68HC11 microprocessor by Motorola Inc. A controller address and control bus 423 also interconnects the peripheral interface 415, the memory controller 401 and the controller microprocessor 417.

[0090] FIG. 7B is a schematic illustration of the functional blocks of the alternative controller module illustrated in FIG. 1B. The controller module 134 contains essentially a memory controller 431 and a power converter 405. The memory controller 431 manages the information flow between the solid-state memory module 131 and the computer system 101. It also sequences various control signals for the operation of the memory devices 141. Unlike the controller module 133 of FIG. 7A, some of the controller module's functions are performed by the system micropro-

cessor 121 and other system resources of the computer system 101 (see FIG. 1B). The memory controller 431 is in direct communication with the system microprocessor 121 via the microprocessor bus 137. Similarly to the memory controller 401, it also controls the output of various voltages required for the operations of the memory device 141 by means of a power supply or converter 405. The device bus 135 links the memory controller 431 and the power supply 405 to the memory devices 141.

[0091] FIG. 8A is a schematic illustration of the functional blocks of the memory controller 401 illustrated in FIG. 7A. As described above, the memory controller 401 is linked to the disk drive interface 411 by means of a serial data line 421 and a controller address and control bus 423. Tracing the data path from the disk drive interface 411 side, the serial data line 421 enters through an I/O port 501 and is converted by a serial/parallel device (SERDES) 511 to a 8-bit parallel bus. It is then switched by a MUX 515 into a FIFO 517 before being serialized and switched out by a MUX/SERDES 519 to an I/O port 521 as the 2-bit serial-in bus S10, S11. On the other hand, the data path from the device bus 135 side has the 2-bit serial-out bus S00, S01 tracing a reverse path along the same functional blocks.

[0092] The memory controller 401 also has an I/O decode (e.g. register strobe/enable decodes) 531, address control registers 533, an error correction code (ECC) hardware 541, a sequencer 543, and a command shift register 545. Addresses and control signals are carried along the controller address and control bus 423. The bus enters through the I/O port 501 and lines therein interconnect the various functional blocks as shown in FIG. 8A. The ECC hardware 541 is used to check and correct errors that may arise in the data (connections not explicitly shown).

[0093] In order to describe the operation of the memory controller 401 in relation to the computer system 101, the controller module 133 and the memory module 131, references are also made to FIGS. 1A, 2 and 7A.

[0094] To initiate the reading or writing of a memory device 141, the system microprocessor 121 initializes internal registers (e.g. address control registers 533) and the sequencer 543 for operation. When a command and accompanying address are received from the host computer system 101 via the peripheral interface 415, the controller microprocessor 417 evaluates the command and translates that command and address to a memory device address and command sequence. The memory device's address is loaded into the address control registers 533 in the memory controller 401. The microprocessor then activates the desired sequence by writing a command vector to the sequencer. This command vector will cause the sequencer to jump to the address value loaded and start executing the code at that address.

[0095] For a read command, the microprocessor receives a command over the host interface via the peripheral interface 415 of the controller module 133. It evaluates this command and translates the address to a memory device address. The microprocessor then loads this address into the address control registers 533. The microprocessor then loads the sequencer 543 with the starting address of the read sequence. The sequence starts executing code at this address. The sequencer 543 first shifts out the select address for selecting a particular memory device chip 141, followed

by a memory chunk (e.g. 64 bits) address from the address control registers through the lines 551 via the MUX/SERDES 519 to the serial-in lines S10, S11. The sequencer then puts out a read command and switches the MUX/SERDES 519 to receive it via the lines 553. The read command is shifted out to the serial-in lines S10, S11. In the meantime, the sequencer 543 is putting out the control signals CS* and P/D* through the command shift registers 545.

[0096] Once the read is started the sequencer 543 enables the FIFO 517 to accept incoming data read from the memory device 141. This data is received into registers in the I/O port 521 and converted to parallel data in the MUX/SERDES 519 before being put into the FIFO 517. At the same time the FIFO 517 is enabled to load data, the ECC hardware 541 is activated and starts calculating on the data loaded into the FIFO. The sequencer 543 looks at a FIFO RDY line (not explicitly shown) to see if a byte of data is ready to be sent to the peripheral interface 415 of the disk drive interface 411. When the FIFO 517 is ready, the sequencer 543 signals the peripheral interface 415 to receive the data and then transmits the data from the FIFO 517 via the SERDES 511 out to the serial line 421.

[0097] In the preferred embodiment, data is written and read in 64-bit chunks. After one chunk of data is read, the sequencer 543 then updates the address control register 533 (chunk counter) and shifts out the address for the next chunk to be read. While reading data from memory, the controller will output the address for the next chunk to be read at the same time it is receiving the read data from the present chunk. The controller supports overlapping operations to give a continuous flow of data. This sequence continues until the last data chunk is read as signaled by the address control registers 533 to the sequencer 543. While data is being received from the memory device 141, it is being gated by the sequencer 543 into the ECC hardware for error checking. The status of the ECC check as to whether data was received correctly is then posted to the controller microprocessor 417. After this, the sequencer 543 checks to see if the FIFO 517 has been emptied, and if so, shuts the I/O ports 501, 521 off and gates to an idle state, waiting for a new command.

[0098] The controller microprocessor 417 of the disk drive interface 411 has a direct path for reading and writing data to and from the memory device 141 via the controller address and control bus 423 and 561 and the MUX/SERDES 519. This is done to support header reads, formatting and diagnostics.

[0099] For a write command, the controller microprocessor 417 of the disk drive interface 411 in the controller module 133 receives a command over the bus interface 138 via the peripheral interface 415 (see also FIGS. 1a, 7a). When the sequencer 543 receive a write vector it will signal and drive an input on the peripheral interface 415 of the disk drive interface 411. The peripheral interface 415 will then initiate the sequencer 543 to have serial data received over the serial line 421. The data received by the SERDES 511 is put in parallel format and written into the FIFO 517 via the MUX 515.

[0100] The addressing of a particular memory device chip and a memory chunk therein is similar to that described for the read operation. While the FIFO 517 is being filled the sequencer 543 has gated the address loaded in the address control registers 533 to the memory device, including the

device chip select address. After a memory device chip is selected and the memory device address is loaded, the sequencer will look at a FIFO RDY line (not explicitly shown) to see if a byte of data is ready to be sent to the memory device 141 via the device bus 135. When the FIFO 517 is ready, the sequencer 543 switches the MUX/SERDES 519 from the address control registers 533 to the FIFO 517 to receive data instead. The sequencer gates out in 64-bit chunk of data, received a byte at a time from the FIFO, and transmits the data via the SERDES/MUX 519 and I/O port 521 out to the Serial-out lines SOO, SOI of the device bus 135. The sequencer 543 then switches the MUX/SERDES 519 again to shift out the required command vectors via the bus 553 to the Serial-in lines S10, S11.

[0101] After the address, command and data have been loaded into the memory device 141, the sequencer will activate the power converter 405 of the controller module 133 by loading the proper values in the power control I/O port registers (not explicitly shown) via a bus 571. The output of these registers drive the inputs to the power converter 405 providing the required voltages for the programming (or writing) of the memory device. These output lines also turn on any programming reference current out of the power converter 405.

[0102] In addition, the sequencer 543 handles the control interface to the memory device 141 by outputting control signals CS*, P/D* via the command shift registers 545. Also, the sequencer keeps track of the write time and at the end of it, halts programming by lowering the programming voltage from the power converter 405.

[0103] In the preferred embodiment, a 64-bit chunk of data is programmed at a time. After a chunk of data is programmed, the sequencer will then issue a pulse to the address control registers 533 updating the chunk address. It then repeats the sequence for the next chunk to be programmed.

[0104] While the data is being gated to the memory device 141, it is also being sent to the ECC hardware 541. After the sequencer has sent the last chunk of data it turns the FIFO 517 off and enables the check bytes in the ECC hardware 541 to be written to the memory device 141. Thereafter, the sequencer is done and returns to the idle state until a new command from the controller microprocessor 417 from the disk drive interface arrives to activate it.

[0105] A memory controller incorporating defect management and a write cache for flash EEPROM devices has been disclosed in co-pending U.S. patent application Ser. No. 337,566, filed Apr. 13, 1989, by Harari et al. The relevant portions of the disclosure from that application are hereby incorporated by reference.

[0106] FIG. 8B is a schematic illustration of the functional blocks of the alternative memory controller 431 illustrated in FIG. 7B. A key feature of this architecture is to have the data that is read or written to be accessed by a host interface 601 used to set up the control. Unlike the embodiment shown in FIG. 8A, this memory controller 431 interfaces directly with the system bus 123 and does not have a bus interface 137 not a disk drive interface 411 inserted therebetween (see FIG. 1B). Tight interaction with the host microprocessor 121 is required.

[0107] The host interface **601** is connected directly to the system bus **123**. It includes an address registers **605** and a serial/parallel converter (SERDES) **607**.

[0108] The memory controller **431** also includes a read/write control block **611** connected in between the host interface **601** and a memory control block **621**. Error correction is performed by an ECC hardware **612**. The read/write (R/W) control block **611** further includes a R/W state machine **613**, control/status registers **615**, a timer interrupt **617**, and a power control **619**. The memory control block **621** further includes a memory protocol state machine **623** and a command/data power gating control **625**. The gating control **625** is for gating commands, addresses, data, and also a programming reference current into the device bus **135** (see also FIG. 7B).

[0109] The design of the memory controller **431** is based on the two state machines **613** and **623** to handle the hardware control. The read/write (R/W) state machine **613** handles the high level details of the operations, while the low level protocol state machine **623** is used to handle the details of the memory-device interface.

[0110] To initiate a write sequence to the memory device **141**, the host microprocessor **121** through the host interface **601** writes the desired starting address into the address registers **605**. The microprocessor also writes the control/status registers **615** with the code for a particular group of memory devices that is to be turned on for this command. In one embodiment, the SERDES **607** also contains memory that allows an entire block of data to be buffered up between the host and the memory device **141**.

[0111] The microprocessor **121** then writes the R/W state machine **613** with a vector for a write command. The R/W state machine **613** selects the address registers **605** as the data source and enables the protocol state machine **623** to begin. Then the protocol state machine **623** serially selects the desired memory device chip and shifts in the desired memory cell address. The protocol state machine **623** also outputs the proper command and starts the shifting of the write data to the memory device. This is done by taking the data out of the SERDES **607** in a serial manner and directing it through the memory control block **621** for shifting to the memory device.

[0112] As data is shifted to the memory device the system microprocessor **121** continues to load data into the SERDES **607** keeping data ready to be shifted to the memory device. As data is being pulled out of the SERDES **607** it is also input to the ECC hardware **612** where the clock bits are being generated.

[0113] When a chunk of data (64 bits) has been shifted to the memory device, the protocol state machine **623** stops sending data and activates the high programming voltages by setting the proper control bits in the power gating of gating control **625** and power control **619**. This in turn drives the power converter **405** of the controller module **134** to output the proper voltages as enabling the programming reference current via serial-in **SI0237**.

[0114] The programming voltages and programming reference current are turned on for a specified duration by the protocol state machine **623** and the sequence is repeated for the next, chunk. If data written to the memory device is the last chunk, the ECC hardware **612** is enabled and its data is

written to the memory device via the device bus **135** by the normal chunk programming operations.

[0115] During the write sequence, status bits from the status registers **605** are available to the host microprocessor **121**. Example of such status bits are data ready/empty, ECC errors etc.

[0116] The read sequence is much like that of write with the flow of data reversed. The microprocessor **121** loads the starting address into the address registers **605**. It then selects the desired group of memory devices by writing the code for them into the control/status registers **615**. The microprocessor then issues the read command to the R/W state machine **613**. It then activates the protocol state machine **623** which shifts out the address of the memory device, causing the proper chip to be serially selected and the starting address to be loaded into the memory device. The protocol state machine **623** also shifts out the read command to the selected memory device and also outputs appropriate control signals (e.g. P/D*) to the control lines in the device bus **135**. The read serial data received from the memory device is then directed by the gating control **625** to the SERDES **607** logic as well as the ECC hardware **612**. The microprocessor **121** then polls a status bit in the status registers **605** to see if a word of data is compiled in the SERDES **607**. When this bit goes active by the proper number of bits being loaded, the micro-processor **121** reads the data from the SERDES **607** and stores it in the host memory **125**. Thus a word of read data at a time is transferred to the host computer system **101**. The controller will output the next address and perform the access delay for the next chunk at the same time the present chunk is being input. This allows for overlapping of access times to get a continuous stream of read bits. This continues until the last data bytes are loaded into the SERDES **607**. In that event, the ECC bytes are fetched from the ECC hardware **612** and compared with the value recorded in the memory's sector. If an error occurs, a correction of the data will be attempted. If no error has occurred the R/W controller halts, stopping the protocol state machine **623**, and waits for a new command to be entered.

[0117] Read Streaming

[0118] An important feature of the present invention as described above is the ability to perform a read streaming function between the memory devices **141** and the controller module **133** or **134** (see FIGS 1A and 1B). Referring to FIGS. 4, 8A and 8B, the memory device **141** supports read streaming by latching the 64 bits (chunk) of parallel information of a read cycle into a holding shift register **219** to be shifted out as a serial stream.

[0119] The timing diagram for read streaming is illustrated in FIG. 9, which is to be referred in conjunction with FIGS. 4, 8A and 8B. At the falling edge of the module select signal **MS***, the current (nth) chunk (64 bits) of data read out and is then shifted to the controller module **133** or **134**. At the controller module, the data is put in deserialized form and stored to be sent over the host interface. While the current (nth) chunk of data is being shifted out to the controller module, the memory controller **401** or **431** also updates the address for the next ((n+1)th) chunk of data to be read, and sends it to the memory device **141**. This address is then used to access the memory device for the next ((n+1)th) chunk of data while the current (nth) chunk of data is still being shifted out. When the last pair of bits of the current chunk

has been shifted out, the next 64 bits of data are already available at the outputs of the 64 sense amplifiers of the read circuit **213**. This information can then be transferred to the 64 bit serial out shift register **219** without the usual memory access delay.

[**0120**] This read streaming sequence is repeated until all data desired by the memory controller **401** or **431** has been fetched from the memory device **141**. By performing reads in this pipeline manner, overall system performance can be improved and the serial data stream is made to look like a continuous bit stream. In contrast, typical memory structures do not have read out time overlapping with address and access times.

[**0121**] While the embodiments of the various aspects of the present invention that have been described are the preferred implementation, those skilled in the art will understand that variation thereof may also be possible. Therefore, the invention is entitled to protection within the full scope of the appended claims.

It is claimed:

1. A mass storage system for use with a computer system, comprising:

a plurality of solid-state memory device chips, each having a large number of memory cells partitioned into individually addressable chunks for write or read operations, said memory cells being organized into one or more sectors individually addressable for erase operation;

a memory chip controller for controlling the plurality of memory chips, said memory chip controller being adapted to communicate with the computer system; and

a device bus for connecting said memory chip controller to each of said plurality of solid-state memory chips, said device bus carrying serialized address, data and command information, thereby substantially reducing the number of connections therebetween.

2. A mass storage system as in claim 1, wherein the memory chips are flash EEPROM devices.

3. A mass storage system as in claim 1, wherein the device bus includes two serial-in lines, two serial-out lines, a clock line, a master chip-select line, a serial protocol control line, and a plurality of power lines.

4. A mass storage system as in claim 3, wherein the memory chips are flash EEPROM devices.

5. A mass storage system as in claim 1, wherein the device bus consists of two serial-in lines, two serial-out lines, a clock line, a master chip-select line, a serial protocol control line, and a plurality of power lines.

6. A mass storage system as in claim 5, wherein the memory chips are flash EEPROM devices.

7. A mass storage system as in claim 1, wherein the mass storage system is adapted to communicate with the computer system via a standard computer system bus, and wherein the mass storage system is adapted to be powered by a standard power supply within the computer system.

8. A mass storage system as in claim 7, wherein the memory chips are flash EEPROM devices.

9. A mass storage system as in claim 1, wherein the mass storage system is adapted to communicate with the computer system via a standard computer bus interface, and wherein

the mass storage system is adapted to be powered by a standard power supply within the computer system.

10. A mass storage system as in claim 9, wherein the memory chips are flash EEPROM devices.

11. A mass storage system as in claim 1, further including:

one or more backplanes each containing a plurality of mounts, each said plurality of mounts adapted to receive one of the plurality of memory chips;

an extension of the device bus to each of the plurality of mounts for connection to the memory chip thereon;

a set of device-select pinouts on each memory chip;

a set of corresponding pads on each mount for connection to the set of device-select pinouts of the memory chips mounted thereon, said set of corresponding pads having a predetermined configuration of grounded pads to define a mount address and therefore a unique array address for each memory chip mounted on each said one or more backplanes.

12. A mass storage system as in claim 11, wherein the memory chips are flash EEPROM devices.

13. A mass storage system as in claim 11, each said memory chip further including:

a device select circuit for enabling the memory chip thereof whenever an array address received from the device bus coincides with the array address obtained from the set of device-select pinouts as defined by the predetermined configuration of grounded bonding pads.

14. A mass storage system as in claim 13, wherein the memory chips are flash EEPROM devices.

15. A mass storage system as in claim 13, said device select circuit further including:

means responsive to an asserting chip-select signal and a clock signal from the device bus for converting a serialized array address from the device bus to a corresponding parallel array address; and

means for asserting a memory chip-select signal whenever a match occurs between the corresponding parallel array address and the array address obtained from the set of device-select pinouts as defined by the predetermined configuration of grounded bonding pads.

16. A mass storage system as in claim 15, wherein the memory chips are flash EEPROM devices.

17. A mass storage system as in claim 13, wherein said device select circuit further including:

a master-select circuit for enabling the memory chip thereof whenever said set of corresponding pads are configured with a predetermined, master-select grounding configuration.

18. A mass storage system as in claim 17, wherein the memory chips are flash EEPROM devices.

19. A mass storage system as in claim 17, wherein the memory chip is enabled by said master-select circuit and a dedicated chip select signal.

20. A mass storage system as in claim 19, wherein the memory chips are flash EEPROM devices.

21. A mass storage system as in claim 11, wherein said device select circuit further including:

a device deselect circuit for disabling each memory chip thereof whenever an array address received from the device bus coincides with a predetermined address.

22. A mass storage system as in claim 21, wherein the memory chips are flash EEPROM devices.

23. A mass storage system as in claim 1, further including:

- one or more memory submodules each containing a plurality of memory-device mounts, each memory-device mount adapted to receive one of the plurality of memory chips;
- one or more backplanes each containing a plurality of submodule mounts adapted to receive one of the plurality of memory submodules;
- an extension of the device bus to each memory submodule for connection to each memory-device mount and therefore to each memory chip thereon;
- a set of device-select pinouts on each memory chip;
- a set of corresponding pads on each memory-device mount for connection to the set of device-select pinouts of the memory chips mounted thereon, said set of corresponding pads being partitioned into first and second subsets of pads;
- said first subset of pads capable of providing group of grounded pads configurations to define unique addresses for all memory-device mounts and therefore addresses for corresponding memory chips mounted on each memory submodule; and
- said second subset of pads being connected to corresponding pads on each submodule mount and capable of providing a second group of grounded pads configurations to define unique addresses for all submodule mounts and therefore addresses for corresponding memory submodules mounted on each backplane.

24. A mass storage system as in claim 23, wherein the memory chips are flash EEPROM devices.

25. A mass storage system as in claim 23, each said memory chip further including:

- a device select circuit for enabling the memory chip thereof whenever an array address received from the device bus coincides with the array address obtained from the set of device-select pinouts as defined by the predetermined configuration of grounded bonding pads.

26. A mass storage system as in claim 25, wherein the memory chips are flash EEPROM devices.

27. A mass storage system as in claim 25, said device select circuit further including:

- means responsive to an asserting chip-select signal and a clock signal from the device bus for converting a serialized array address from the device bus to a corresponding parallel array address; and
- means for asserting a memory chip-select signal whenever a match occurs between the corresponding parallel array address and the array address obtained from the set of device-select pinouts as defined by the predetermined configuration of grounded bonding pads.

28. A mass storage system as in claim 27, wherein the memory chips are flash EEPROM devices.

29. A mass storage system as in claim 25, wherein said device select circuit further including: a master-select circuit for enabling the memory chip thereof whenever said set of corresponding pads are configured with a predetermined, master-select grounding configuration.

30. A mass storage system as in claim 29, wherein the memory chips are flash EEPROM devices.

31. A mass storage system as in claim 29, wherein the memory chip is enabled by said master-select circuit and a dedicated chip select signal.

32. A mass storage system as in claim 31, wherein the memory chips are flash EEPROM devices.

33. A mass storage system as in claim 23, wherein said device select circuit further including:

- a device deselect circuit for disabling each memory chip thereof whenever an array address received from the device bus coincides with a predetermined address.

34. A mass storage system as in claim 33, wherein the memory chips are flash EEPROM devices.

35. A mass storage system as in claim 1, each said solid-state memory device further including:

- a serial protocol logic for controlling the protocol of the serialized address, data and command information carried in the device bus, said serial protocol logic comprising;
- means for routing and converting serialized addresses from the device bus to a parallel address bus;
- means for routing and converting serialized data from the device bus to a parallel data bus;
- means for routing and converting serialized command codes from the device bus to a plurality of parallel command lines;
- a pointer shift register means for capturing a code from the device bus;
- a pointer decode means for selectively enable said one of the routing and converting means; and
- a serial protocol control signal from the device bus for enabling said pointer shift register means for capturing the code from the device bus while disabling said converting means, and for disabling said pointer shift register means after the code has been captured and enabling said routing and converting means.

36. A mass storage system as in claim 35, wherein the memory chips are flash EEPROM devices.

37. A method for transferring command, address and data information between two system via a serial bus connected therebetween, comprising the steps of:

- serializing each command, address or data information into respective string components;
- providing a code tag to each respective string component;
- multiplexing the respective string components into a serial stream so that each respective string component has a definite start and end time sequence and is preceded by its corresponding tag code;
- providing a serial protocol control signal which provides a time reference for the start and end of each respective string component in the serial stream;

transferring the serial stream and the serial protocol control signal from one system to another system;

detecting the start and end of each respective string component in the serial stream by reference to the serial protocol control signal;

reading the tag code of each respective string component and routing each respective string component in the serial stream accordingly, thereby extracting each command, address or data string components from the serial stream in the other system.

38. A method as in claim 37, further comprising the step of:

converting each routed command, address and data information back to a parallel format.

39. In a memory system having at least one memory device in communication with a controller, said memory device transferring data with the controller serially, an improved method of reading data stored in the memory device, comprising the steps of:

reading a new chunk of data as a current chunk of data from the memory device in parallel;

converting the current chunk of read data from parallel to serial format and shifting out to the controller;

setting up the address for the next chunk of data to be read and sending it from the controller to the memory device while the current chunk of data is being shifted out from the memory device to the controller;

accessing the memory device with the address for the next chunk of data while the current chunk of data is being shifted out from the memory device to the controller; and

repeating all the above steps, after the current chunk has been shifted out of the memory device, until all chunks to be read have been shifted out of the memory device.

* * * * *