



(19) **United States**

(12) **Patent Application Publication**  
**Bohine, JR.**

(10) **Pub. No.: US 2007/0040673 A1**

(43) **Pub. Date: Feb. 22, 2007**

(54) **APPARATUS AND METHOD FOR ASYNCHRONOUSLY ANALYZING DATA TO DETECT RADIOACTIVE MATERIAL**

(60) Provisional application No. 60/460,202, filed on Apr. 3, 2003. Provisional application No. 60/456,754, filed on Mar. 21, 2003. Provisional application No. 60/445,408, filed on Feb. 6, 2003. Provisional application No. 60/407,148, filed on Aug. 28, 2002. Provisional application No. 60/388,512, filed on Jun. 12, 2002.

(75) Inventor: **Jerry Bohine JR.**, Gates Mills, OH (US)

**Publication Classification**

Correspondence Address:  
**AKIN GUMP STRAUSS HAUER & FELD L.L.P.**  
**ONE COMMERCE SQUARE**  
**2005 MARKET STREET, SUITE 2200**  
**PHILADELPHIA, PA 19103 (US)**

(51) **Int. Cl.**  
**H04Q 7/00** (2006.01)  
(52) **U.S. Cl.** ..... **340/539.26**

(73) Assignee: **Quintell of Ohio, LLC**

(57) **ABSTRACT**

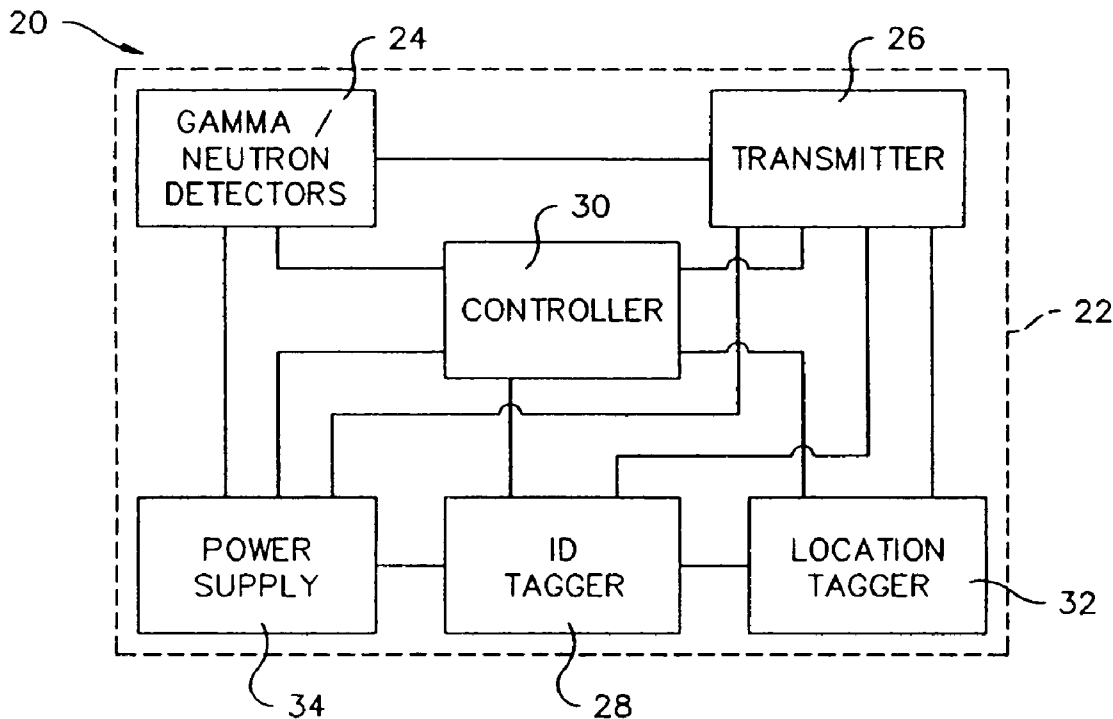
(21) Appl. No.: **11/177,857**

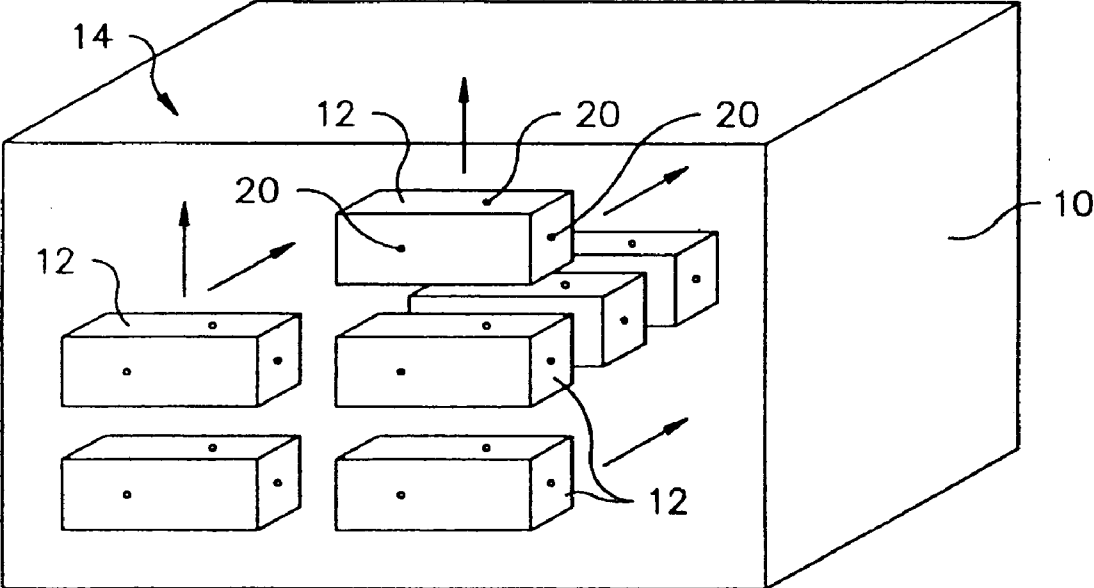
(22) Filed: **Jul. 8, 2005**

A radioactive material detection system includes a cargo container monitoring system and a control center. The cargo container monitoring system has a radiation sensor configured to detect radiation over a predetermined or commanded period of time and a transceiver configured to send the information received from the radiation sensor. The control center is in communication with the transceiver of the cargo container monitoring system. The control center is configured to receive data from at least one additional source other than the cargo container monitoring system and to asynchronously analyze the data from the at least one additional source and the information from the radiation sensor, during transit, so as to detect radioactive material in a cargo container.

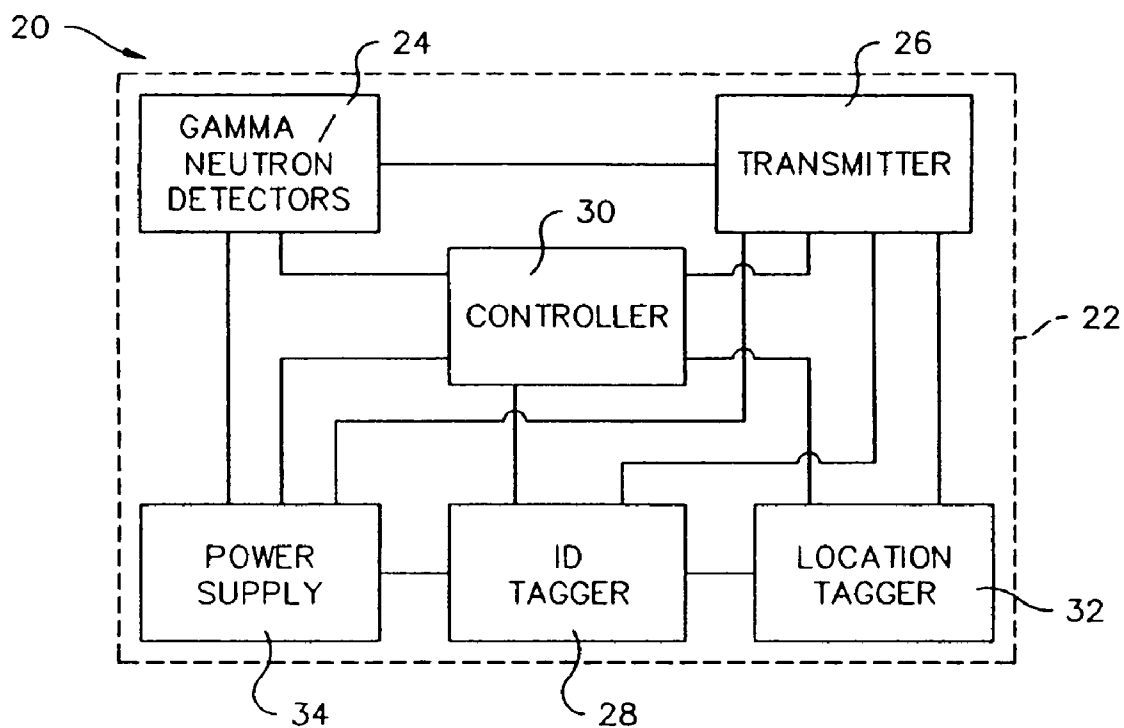
**Related U.S. Application Data**

(63) Continuation of application No. 10/801,357, filed on Mar. 16, 2004, now Pat. No. 6,965,314, which is a continuation-in-part of application No. 10/458,923, filed on Jun. 10, 2003, now Pat. No. 6,891,470.

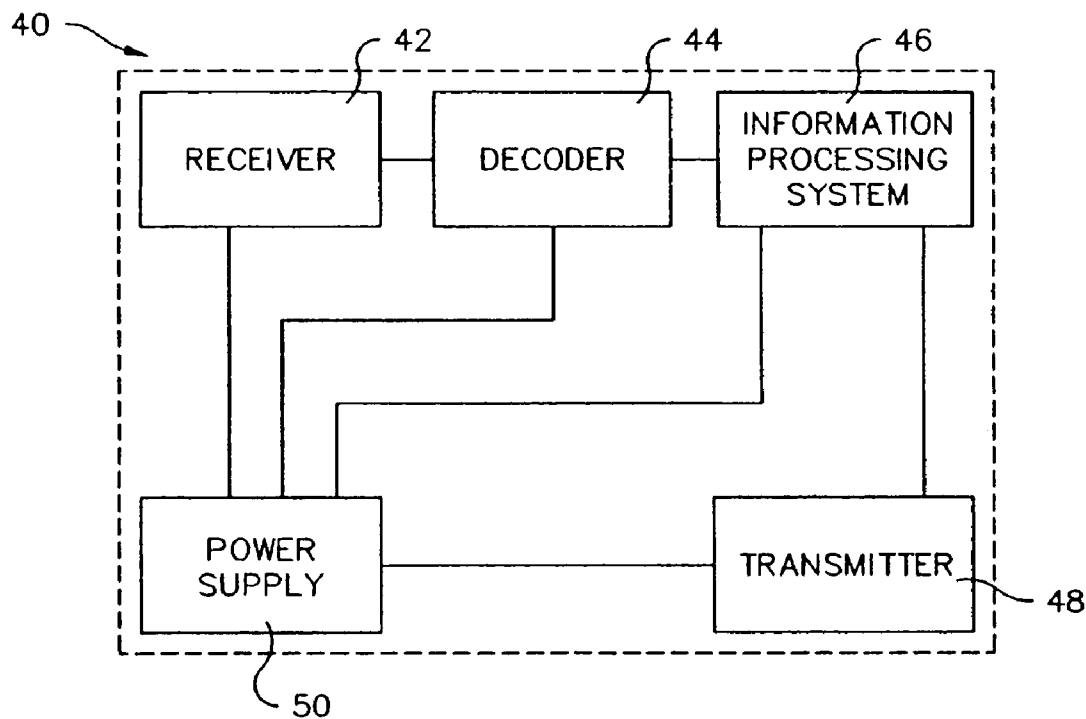




*Fig. 1*



**Fig. 2**



**Fig. 3**

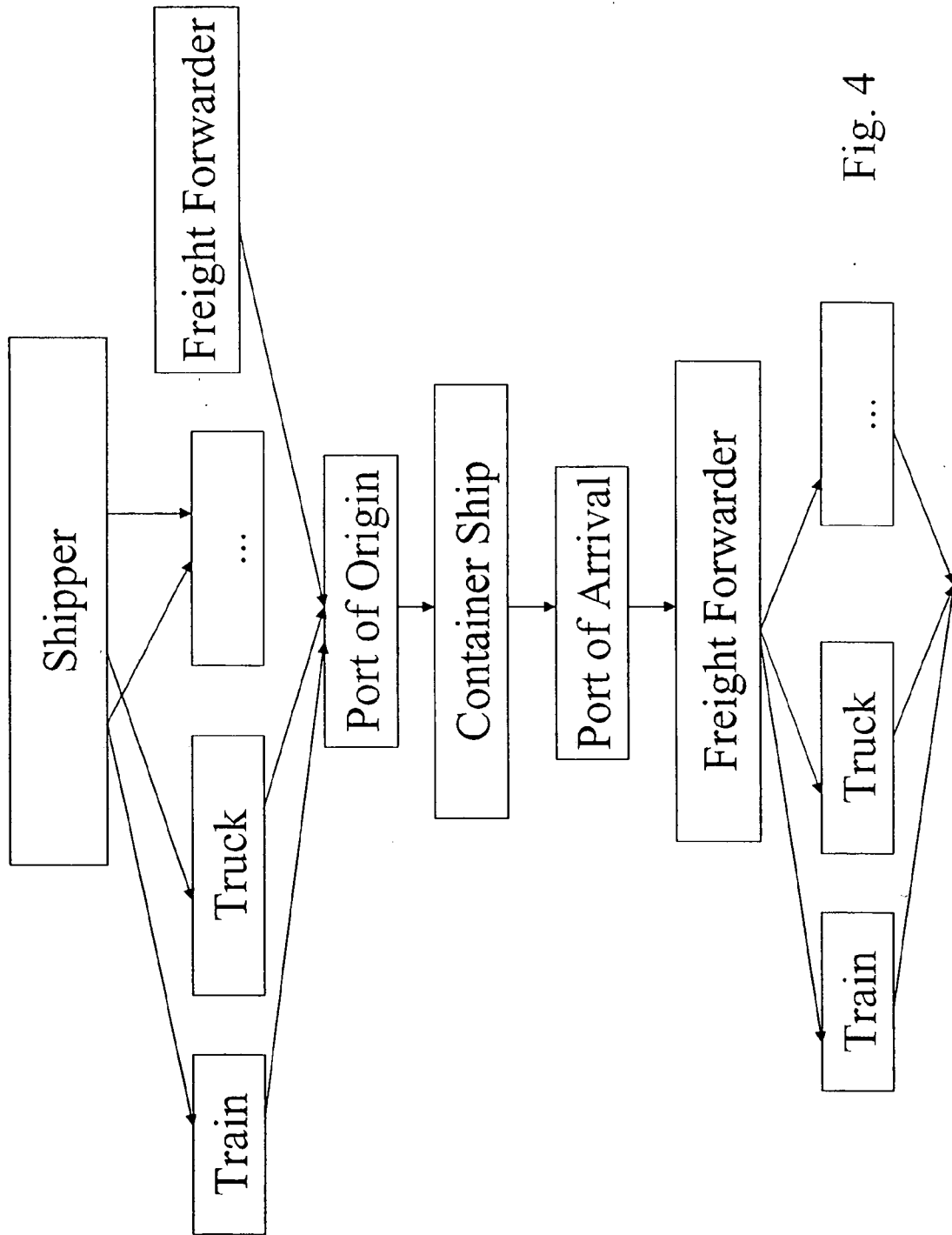


Fig. 4

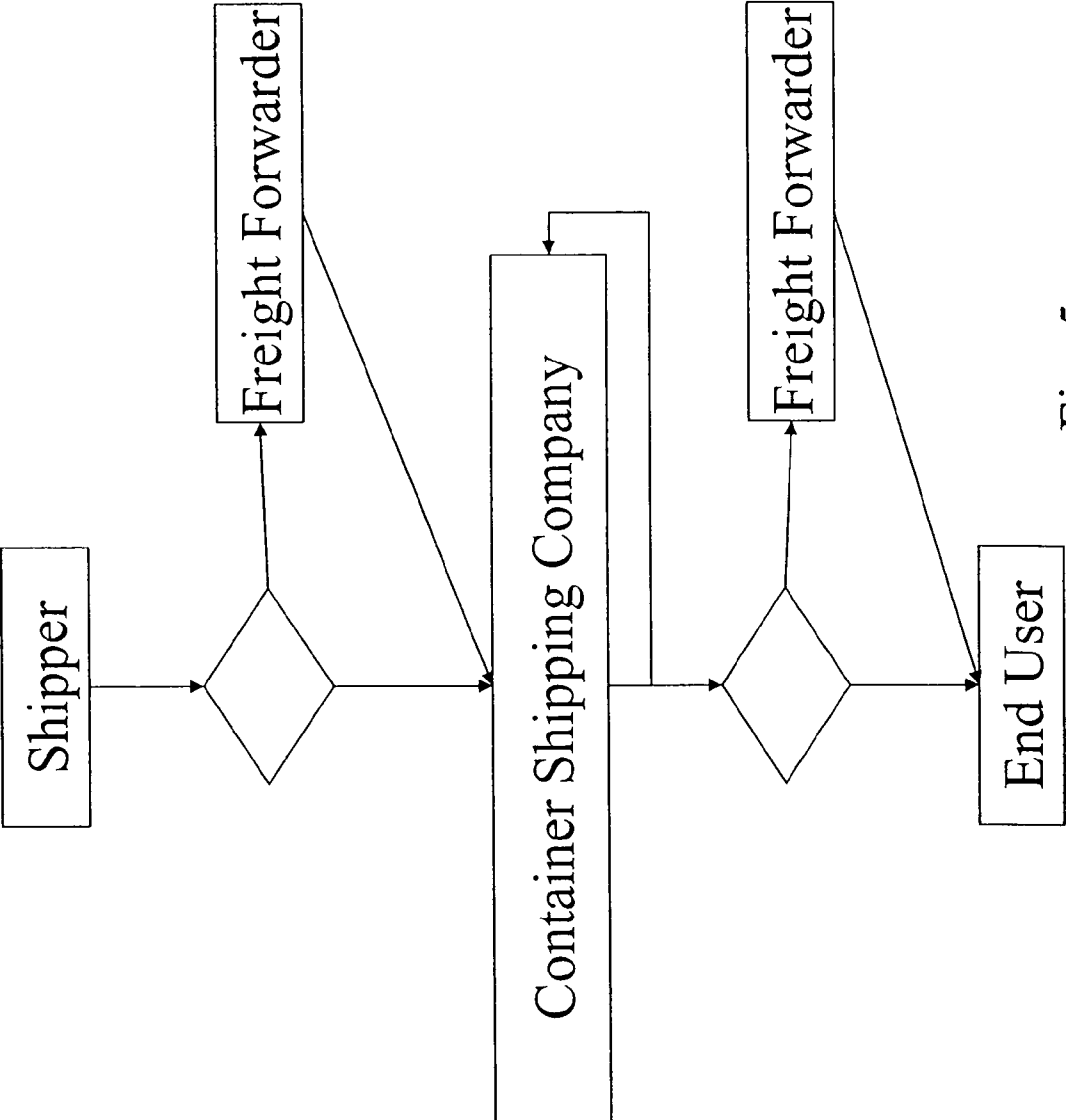


Fig. 5

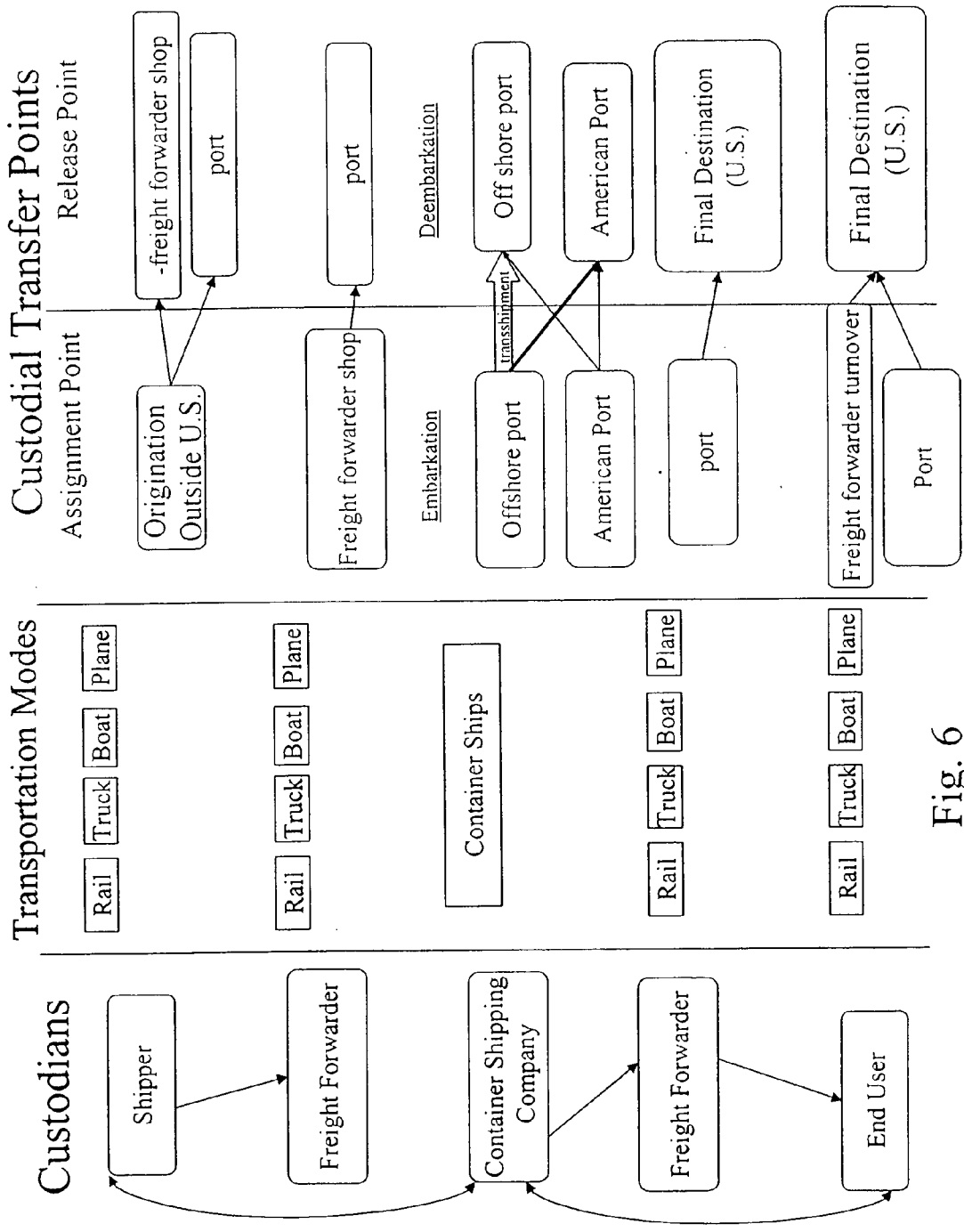


Fig. 6

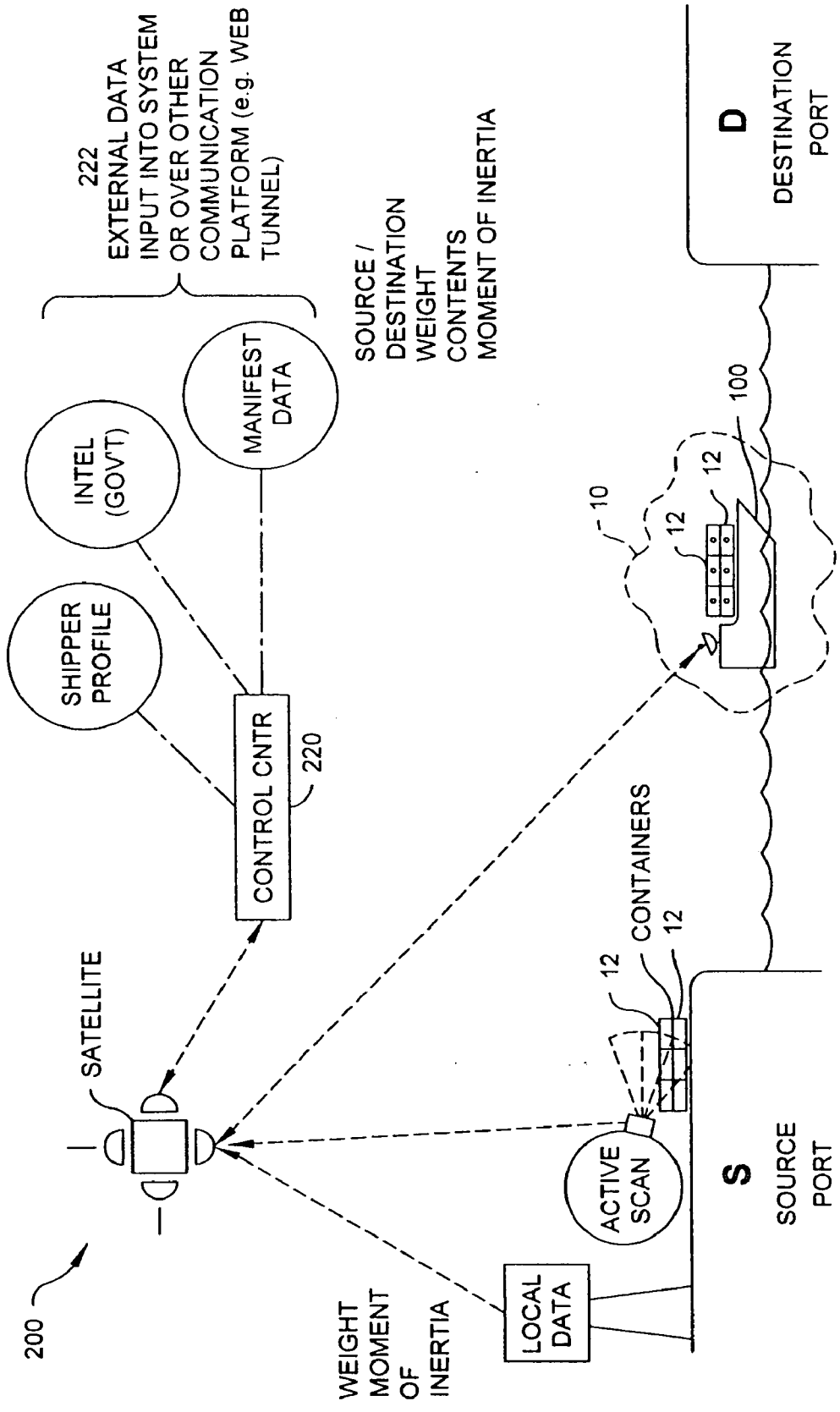
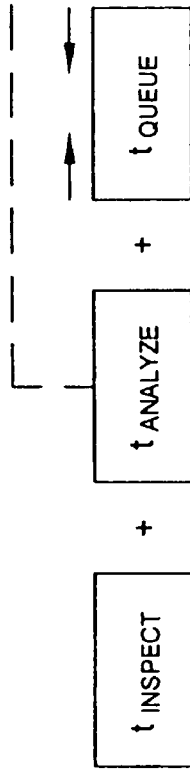


Fig. 7

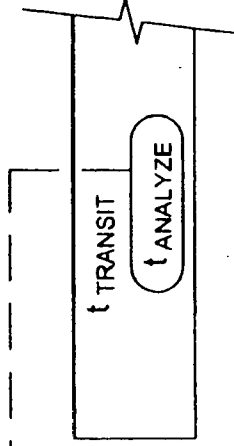
**ACTIVE OR PASSIVE  
INSPECTION AT A  
PORT OF TIME T**



$$T = t_{INSPECT} + t_{ANALYZE} + t_{QUEUE}$$

Where  $t_{QUEUE} = f(t_{ANALYZE})$

**ACTIVE INSPECTION  
COMBINED WITH  
CARGO CONTAINER  
MONITOR SYSTEM 10**



$$t_{QUEUE} \propto \text{Constant}$$

OR  $t_{QUEUE} \neq f(t_{ANALYZE})$

**Fig. 8**



**APPARATUS AND METHOD FOR  
ASYNCHRONOUSLY ANALYZING DATA TO  
DETECT RADIOACTIVE MATERIAL**

**CROSS REFERENCE TO RELATED  
APPLICATIONS**

[0001] This application is a continuation of U.S. patent application Ser. No. 10/801,357 filed Mar. 16, 2004, entitled "Apparatus and Method for Asynchronously Analyzing Data to Detect Radioactive Material," which is a continuation-in-part of U.S. patent application Ser. No. 10/458,923 filed Jun. 10, 2003, entitled "Method and Apparatus for Detection of Radioactive Material," the entire contents of which are incorporated by reference herein.

[0002] This application claims the benefit of U.S. Provisional Patent Applications No. 60/460,202 filed on Apr. 3, 2003; 60/456,754 filed on Mar. 21, 2003; 60/445,408 filed Feb. 6, 2003; 60/407,148 filed Aug. 28, 2002; and 60/388,512 filed Jun. 12, 2002, all entitled "Method and Apparatus for Detection of Radioactive Material," the entire contents of which are incorporated by reference herein.

**BACKGROUND OF THE INVENTION**

[0003] The present invention relates generally to an apparatus and method for asynchronously analyzing data to detect nuclear weapons and/or radioactive material and, more particularly, to an apparatus and method for asynchronously analyzing data to detect nuclear weapons and/or radioactive material within a vessel or container during shipment from one location to another.

[0004] There is a growing concern that terrorists or others may at some time in the near future attempt to import into the United States or some other country radioactive or nuclear material which may then be used for the construction of a nuclear weapon for carrying out terrorist objectives. One way of shipping such radioactive or nuclear material is to hide the material among or within seemingly innocuous cargo. For example, such nuclear material could be placed within a standard, sealed cargo container of the type typically employed for shipping cargo by sea, rail, air or by truck. The nuclear material could be positioned within such a sealed cargo container along with other innocuous goods with the container being positioned, for example, within the hold of a large container ship which may be transporting a thousand or more such containers from one location to another. Typically, existing cargo inspection systems are employed either at the port of debarkation or the port of entry for such container ships. Because of the large number of containers which are typically transported by a single large container ship, it is difficult, if not impossible, using the presently available inspection equipment and personnel to thoroughly check each and every container for the presence of any type of contraband, including radioactive or nuclear material. A more typical scenario presently is to provide spot-checks of a certain number of containers in a given shipment using, for example, active scanning technology such as X-ray, gamma ray or even neutron interrogation of the selected containers which is done on a small sub-set of the overall number of containers. An active scan is anytime an outside energy source is introduced to interrogate or stimulate materials within an object such as a container. Active scans may include neutrons, Gamma rays,

magnetic resonance, electromagnetic waves such as infrared, radiofrequency, X-ray, conceivably even ultrasonic, and the like. Generally, active scanning systems include a neutron detector of some sort for detecting neutrons emitted from excited materials within the object or container.

[0005] Other types of scanning technologies, which are not fully commercially developed, but which may also be considered to be active scanning inspection systems include nuclear fluorescence and thermal nuclear analysis (TNA). A nuclear fluorescence system irradiates an object to be tested with a particular radiant spectrum and if there is nuclear material within the object a different energy is emitted back out from the object. For example using neutrons from a deuterium-deuterium reaction, such neutrons have sufficient energy to activate Uranium-235 or Plutonium, among others, which causes a fission reaction in that material (e.g., input 4-5 MeV and get 6+ MeV out due to the fission reaction). Detecting a higher energy output from the object is an indication that there is an "amplifier" inside the object. Thermal neutrons used in TNA have a very low velocity. If a neutron is produced in a fission reaction activated by a thermal neutron, it usually emitted at high energy nominally 2 MeV where 1 eV is equivalent to about 10K degrees with one degree of freedom. The presence of fissionable material is revealed by detection of such a high energy emission. Presently, active scanning inspection equipment do not operate and get analyzed quickly enough to provide real-time scanning for every container. One proposed solution is to scan the containers as they are received at the port of loading and then put the containers in storage pending on-loading. The analysis time of such scanned images slows that process because it requires expertise (similar to radiology and X-ray interpretation). When the data has been analyzed, a particular container may then be flagged for a more thorough or detailed inspection which not only causes delays in the transport of the containers, as well as potential huge back ups in the loading and unloading of the container ships, but is too late in detecting the presence of nuclear material or suspected shielded containers.

[0006] Another way to analyze containers for potential threats is by analyzing manifest information or container source/destination data. A problem with detecting nuclear and fissile materials shielded in containers using only container manifest information or container source/destination data are potential transshipment diversionary tactics. Terrorists wishing to conceal the nuclear material and/or shielding may make modifications to the container or the container contents in an attempt to veil nuclear material and/or shielding. Alternatively, such terrorists may ship the containers to a number of intermediate destinations which would not be recognized as high risk sources themselves directly. Likewise, a terrorist organization may bribe, coerce, convince or dupe a shipper, such as a "less than container load" (LCL) shipper, into adding an illicit crate into a consolidated shipment. In an extreme case, a terrorist organization may acquire a company that already has an established shipping record for innocuous materials and ship an entire container loaded with nuclear material under the name of the acquired company. The likelihood of detecting such a container by spot check active scanning and limited manifest information or container source/destination data is very low.

[0007] It is desirable to have an apparatus and method for asynchronously analyzing data to detect radioactive material

within a sealed container which is within a vessel while the container is in transit from one location to another. In this manner, it is possible to more accurately identify potential threats while in transit using data from multiple sources to permit appropriate action to be taken long before the radioactive or nuclear material enters the territorial limits of a country.

#### BRIEF SUMMARY OF THE INVENTION

[0008] Briefly stated, the present invention comprises a radioactive material detection system including a cargo container monitoring system and a control center. The cargo container monitoring system includes a plurality of radioactive material detection apparatuses each having a wireless transmitter, a radiation sensor configured to detect radiation over a predetermined or commanded period of time, a detection controller configured to send sensed radiation to the wireless transmitter for transmission and an identification tag electrically coupled to one of the controller and the wireless transmitter and configured to provide identification data or location data to the information being transmitted by the wireless transmitter. The cargo container monitoring system also includes a master unit/master module having a receiver configured to receive the wirelessly transmitted information from each of the wireless transmitters of the plurality of radioactive material detection apparatuses, a transceiver and a master controller coupled to the receiver and configured to send the information received from the radioactive material detection apparatuses through the transceiver. The control center is in communication with the transceiver of the master unit/master module. The control center is configured to receive data from at least one additional source other than the master unit/master module and to asynchronously analyze the data from the at least one additional source and the information from the radioactive material detection apparatuses so as to detect radioactive material in a particular container.

[0009] In yet another aspect, the present invention comprises a method of detecting radioactive material within a plurality of containers using a radioactive material detection system. The radioactive material detection system includes a cargo container monitoring system and a control center. The cargo container monitoring system includes a plurality of radioactive material detection apparatuses and a master unit/master module. The plurality of radioactive material detection apparatuses each have a wireless transmitter, a radiation sensor, a detection controller and an identification tag. The master unit/master module has a receiver configured to receive the wirelessly transmitted information from each of the wireless transmitters, a transceiver and a master controller. The control center is in communication with the transceiver of the master unit/master module. The control center is configured to receive data from at least one additional source other than the master unit/master module and to asynchronously analyze the data from the at least one additional source and the information from the radioactive material detection apparatuses so as to detect radioactive material in a particular container. The method includes using the master unit/master module and the plurality of radioactive material detection apparatuses to sense at least one of gamma radiation and neutrons at each radioactive material detection apparatus and transmit the initially sensed signal to the master unit/master module; establishing a background radiation space for the plurality of containers based upon the

initially sensed signals; storing the background radiation space in the master unit/master module or the control center; sensing at least one of gamma radiation and neutrons over the predetermined or commanded period of time at each radioactive material detection apparatus and transmitting the currently sensed signal to the master unit/master module; establishing a current radiation space for the plurality of containers based upon the currently sensed signals; comparing the current radiation space as currently sensed by the radioactive material detection apparatuses to the background radiation space as initially sensed by the radioactive material detection apparatuses in order to identify an anomaly amongst the plurality of containers; asynchronously analyzing the data from the at least one additional source and the compared information so as to identify an anomaly amongst the plurality of containers, to reduce false positives, to reduce false negatives and/or to increase a sensitivity reading.

[0010] In yet another aspect, the present invention comprises a method of detecting radioactive material within a plurality of containers using a radioactive material detection system. The radioactive material detection system includes a cargo container monitoring system and a control center. The cargo container monitoring system includes a master unit/master module and a plurality of radioactive material detection apparatuses. Each radioactive material detection apparatus has a transmitter, a detection controller and a radiation sensor configured to detect radiation over a predetermined or commanded period of time. The control center is in communication with the master unit/master module and is configured to receive data from at least one additional source other than the master unit/master module. The method includes: sensing radiation at each radioactive material detection apparatus; receiving sensed information from each radioactive material detection apparatus at the master unit/master module, over the predetermined or commanded period of time; adjusting for background or cosmic radiation to create adjusted sensor information and to facilitate the identification of an anomaly or unusual data which is likely to indicate the presence of nuclear radioactive material; and asynchronously analyzing the data from the at least one additional source and the adjusted sensor information so as to identify an anomaly amongst the plurality of containers, to reduce false positives, to reduce false negatives and/or to increase a sensitivity reading.

[0011] In yet another aspect, the present invention comprises a method of detecting radioactive material within a plurality of containers using a radioactive material detection system. The radioactive material detection system includes a cargo container monitoring system and a control center. The cargo container monitoring system includes a master unit/master module and a plurality of radioactive material detection apparatuses. Each apparatus has a transmitter, a detection controller and a radiation sensor configured to detect radiation over a predetermined or commanded period of time. The control center is in communication with the master unit/master module and is configured to receive data from at least one additional source other than the master unit/master module. The method includes: mounting the plurality of radioactive material detection apparatuses to the plurality of cargo containers, the total set of detection apparatuses comprising an array of detector and cargo container locations; sensing at least one of gamma radiation and neutrons in totality and/or by spectral distribution over

the predetermined or commanded period of time at each radioactive material detection apparatus and transmitting signals representing measured radiation to the master unit/master module; calculating an average measured radiation level at each radioactive material detection apparatus location throughout the entire array of radioactive material detection apparatuses by averaging the radiation sensed at radioactive material detection apparatuses proximate to each radioactive material detection apparatus, the set of average values for the plurality of radioactive material detection apparatuses forming a varying set of calculated estimates of background radiation space for the plurality of radioactive material detection apparatuses and corresponding cargo containers; and comparing the measured radiation at each radioactive material detection apparatus location to the calculated estimate of background radiation at each location in order to create compared sensor information; and asynchronously analyzing the data from the at least one additional source and the compared sensor information so as to identify an anomaly amongst the plurality of containers, to reduce false positives, to reduce false negatives and/or to increase a sensitivity reading.

#### BRIEF DESCRIPTION OF THE SEVERAL VIEWS OF THE DRAWINGS

[0012] The following detailed description of preferred embodiments of the invention will be better understood when read in conjunction with the appended drawings. For the purpose of illustrating the invention, there are shown in the drawings embodiments which are presently preferred. It should be understood, however, that the invention is not limited to the precise arrangements and instrumentalities shown.

[0013] In the drawings:

[0014] FIG. 1 is a functional block diagram of a cargo container monitoring system having a plurality of radioactive material detection apparatuses arranged on a plurality of objects to be tested which are arranged in a three-dimensional matrix in accordance with the preferred embodiments of the present invention;

[0015] FIG. 2 is a schematic functional block diagram of a radioactive material detection apparatus in accordance with the preferred embodiments of the present invention;

[0016] FIG. 3 is a schematic functional block diagram of a master unit/master module or receiver station in accordance with the preferred embodiments of the present invention;

[0017] FIGS. 4-5 are a flow diagram demonstrating a transit path of a container from a source to a destination;

[0018] FIG. 6 is a functional diagram demonstrating custodial transfer points during transit for a container;

[0019] FIG. 7 is a schematic functional block diagram of a radioactive material detection system in accordance with a preferred embodiment of the present invention; and

[0020] FIG. 8 is a graphic demonstrating a general asynchronous analysis in accordance with the preferred embodiments of the present invention as compared with the time for inspection, analysis and queue of an active scanning system functioning alone.

#### DETAILED DESCRIPTION OF THE INVENTION

[0021] Referring to the drawings, wherein the same reference numerals are employed for indicating like elements throughout the several figures, there is shown in FIGS. 1-3, a schematic representation of a cargo container monitoring system 10 in accordance with preferred embodiments of the present invention. The cargo container monitoring system 10 (FIG. 1) includes a plurality of radioactive material detection apparatuses 20 (FIG. 2) and a master unit/master module 40 (FIG. 3). Each radioactive material detection apparatus 20 includes a transmitter 26, a radiation detector or sensor 24, a detection controller 30 and an identification tag or ID tagger 28. Each transmitter 26 is capable of transmitting information in correspondence with a signal. Preferably, the transmitter 26 transmits information using radio frequency, infrared, light waves, microwaves, electrical voltage, electrical current and the like. Each radiation sensor 24 has a sensor output and is configured to detect radiation over a predetermined or commanded period of time. Preferably, the radiation sensor 24 is configured to vary the sensor output in proportion to an amount of radiation detected. The amount of radiation detected may be an amount of intensity or a cumulative value as sensed over a predetermined or commanded period of time. Each detection controller 30 is configured to receive the output from its associated radiation sensor 24 and to send its respective output signal to its respective transmitter 26 for transmission. Each identification tag 28 is electrically coupled to at least one of the controller 30 and the transmitter 26 and is configured to provide identification data and/or location data to the information being transmitted by the transmitter 26. The identification data may include a unique identifier for an object to be tested 12, and may additionally include information about the contents, ownership, source and/or destination of the object to be tested 12. Preferably, the radiation sensor 24 varies the sensor output in proportion to an amount of radiation detected.

[0022] The master unit/master module 40 includes a receiver 42, an indication output such as transmitter or transceiver 48 of the master unit/master module 40 and a master controller or information processing system 46. The receiver 42 is configured to receive the transmitted information from each of the transmitters 26 of the radioactive material detection apparatuses 20. The master controller 46 is coupled to the receiver 42 and is configured to drive an indication output or transmitter 48 based upon a status of the information received. The indication output 48 may be connected to a remote or local indicator light, annunciator panel, display device, sound generating device (i.e., a horn or a buzzer), and the like. Alternatively, the indicator output 48 may be a transmitter or transceiver 48 connected to a remote communication system such as a cellular system, a telephonic system, a wired computer network, a satellite system, a radio system and the like for communicating with a control center 220 (FIG. 7).

[0023] Preferably, a plurality of subsets of the plurality of radioactive material detection apparatuses 20 are arranged on a plurality of objects to be tested 12, as depicted in FIG. 1, and the plurality of objects to be tested 12 are arranged such that subsets of the plurality of radioactive material detection apparatuses 20 arranged on adjacent objects to be tested 12 are capable of detecting at least a portion of other

adjacent objects to be tested **12** nearest thereto. For example, a first subset of the plurality of radioactive material detection apparatuses **20** may be arranged on a first object to be tested **12** and a second subset of the plurality of radioactive material detection apparatuses **20** may be arranged on a second object to be tested **12**. The first and second objects to be tested **12** are arranged such that the first subset of the plurality of radioactive material detection apparatuses **20** is capable of detecting at least a portion of the second object to be tested **12** and vice versa. Preferably, at least three of the plurality of radioactive material detection apparatuses **20** are arranged on each object to be tested **12** and are oriented on the object to be tested **12** in a manner that minimizes the distance from any point within the object to be tested **12** to one of the three radioactive material detection apparatuses **20**. It is contemplated that a plurality of radioactive material detection systems **10** can be inter-connected by a supervisory monitoring or control station for monitoring a plurality of floors, areas, buildings, holds and the like.

[0024] In one possible implementation, FIG. 1 may be a schematic representation of the hold of a typical container ship **100** (FIG. 7) of a type well known to those of ordinary skill in the art. The container ship **100** includes the cargo container monitoring system **10** which is employed for receiving within its hold and, in some cases upon its deck, a plurality of objects to be tested such as box-like cargo containers **12** generally of a predetermined size of approximately 10 feet by 10 feet by 40 feet or 10 feet by 10 feet by 20 feet. The cargo containers **12** are preloaded with goods to be shipped from one location to another before being loaded onto the container ship **100**. Typically, the containers **12** preloaded with the goods to be shipped are sealed before being placed on the container ship **100**. The hold of the container ship **100** is sized for receiving a plurality of such containers **12** in a side by side, end to end relationship with other containers **12** being stacked one on top of another to effectively establish a three dimensional container matrix **14** to take advantage of the available space of the container ship **100** for maximum shipping efficiency. The containers **12** are typically made of steel or some other rigid, high strength material in order to provide adequate support for the overlying containers **12** and to adequately protect the goods being shipped within each container **12** from damage which may occur during shipment and the loading/unloading of the containers **12**. A typical large container ship **100** may receive one thousand or more containers **12** for shipping from one location to another. As mentioned above, because of the size of the containers **12** and the number of containers on each container ship **100**, it is difficult if not impossible to adequately inspect each and every container for contraband, including radioactive material, at the time the containers **12** are being unloaded from the container ship **100** for further transport.

[0025] The term cargo container **12** as used herein should not be construed as limiting and may include any cargo receptacle, box, or container in which material is held or carried, and/or may include large equipment being shipped which itself could constitute a sort of container (e.g., a pre-fabricated machine or building).

[0026] The present invention provides a method and system for detecting the presence of radioactive or nuclear material within such containers **12** on a container ship **100** (or in some other mode of transport) as the ship is trans-

porting the containers **12** from one location to another (see FIGS. 4-6). Typically, the ocean transit time of a container ship **100** is at least several days and could be as many as 10 or more days from the time a loaded container ship **100** leaves a port at a first location until the time that the container ship **100** enters a port at a second location. For shipments between Western Europe and the United States, a typical transit time is in the range of 9 to 11 days for an east coast U.S. port. The present invention takes advantage of the relatively long transit time to facilitate an orderly, thorough detection of the presence of radioactive or nuclear material within a container **12** without creating any unacceptable delays or port congestion either at the departure or arrival port of the container ship **100**. In this manner, appropriate action may be taken while the ship **100** is still out to sea, long before approaching or entering a port. In addition, because the presence of nuclear or radioactive material can be detected while the ship **100** is at sea, the ship **100** can be held outside of a port to prevent entry of the material into a country or may be diverted to a safe harbor for further inspection.

[0027] FIG. 2 is a functional schematic block diagram of the sensor apparatus **20** in accordance with the preferred embodiments of the present invention. The sensor apparatus **20** is contained within a housing **22** which is preferably sealed and is made of a generally rigid high strength material such as a polymeric material. Preferably, the sensor housing **22** is tamper resistant and includes a mechanism for identifying by a quick, visual or other inspection whether the housing **22** has been opened or otherwise tampered with and or an internal electronic means to detect tampering. The housing **22** is adapted to be secured to the inside or outside of a container **12** at a predetermined location. Various techniques and methods well known to those of ordinary skill in the art may be employed for securing the housing **22** to the container **12** including the use of one or more mechanical fasteners such as screws, bolts, clamps, etc., the use of an adhesive or epoxy adhesive, suction cups, a magnetic attachment device or any other suitable attachment device or technique. Preferably, the housing **22** is adapted to be temporarily secured to an interior or exterior surface of the container **12**. Thus, the radioactive material detection apparatus **20** may be a portable unit. However, it is within the scope and spirit of the present invention that the housing **22** be permanently secured to a container **12**. Preferably, the location on the container **12** where the housing **22** is secured will be such that the housing **22** will not affect the loading or unloading of the container **12** or the stacking of the containers **12** in the three dimensional matrix **14**. Preferably, the housing **22** is relatively small as compared to the container **12** or other object to be tested.

[0028] Referring again to FIG. 2, the housing **22** contains the components necessary for passive detection of the presence of radioactive material over the time period during which the container ship **100** moves from one port to another. In the present embodiment, the housing **22** includes a gamma radiation detection sensing component or sensor **24**, a transmitter **26**, an identification component or ID tagger **28**, a controller **30**, a location component or tagger **32** and a power source **34** for providing operating power to the other components as needed. Preferably, the gamma radiation sensor component **24** is a self-contained passive device capable of sensing the presence of gamma radiation emitted from radioactive material which may be present within or

near the container 12 to which the sensor apparatus 20 is attached. The gamma radiation sensing component 24 is preferably of a type which is generally well known to those of ordinary skill in the art and is available from several sources. The gamma radiation sensing component 24 provides an electrical output signal which is proportional to the sensed gamma radiation. The output from the gamma radiation sensing component 24 is supplied as an input to the transmitter 26. The output of the radiation sensor 24 may also be accumulated over a predetermined or commanded intervals of time prior to transmission to transmitter 26. Suitable signal conditioning components (not shown) may be interposed between the gamma radiation sensing component 24 and the transmitter 26.

[0029] The purpose of the gamma radiation sensing component 24 is to maximize sensitivity and thus the detection of counterband radioactive or nuclear material (fissile material). However, sensitive gamma ray detectors may also be sensitive to particular radioactive isotopes occurring naturally as trace elements within certain commercially acceptable materials. Potassium 40 which occurs in potassium based fertilizer as well as the decay products of trace radioactivity in clay are examples of commercially acceptable materials which may be detected by the gamma radiation sensing component 24. Man-made radioactive materials intended for use in medical or industrial applications which may also be legally shipped in cargo containers could also be detected. Thus, the detection by the gamma radiation sensing component 24 of the present system could constitute false detection of apparently clandestine fissile material.

[0030] One way to minimize the occurrence of such false positive detections is by using a separate detector which is sensitive to neutrons, along with the gamma radiation sensing component 24. The vast majority of naturally occurring radioactive elements and of man-made radioactive isotopes do not emit neutrons whereas fissile materials do emit neutrons. In this manner, simultaneous monitoring using the gamma radiation sensing component 24 along with a neutron monitoring component permits differentiation between the fissile materials and other radioactive sources.

[0031] Another way of identifying potential false positive detections by the gamma radiation sensing component 24 is by also detecting gamma-ray spectral characteristics. Each radioactive isotope emits gamma rays having an identifiable characteristic energy spectrum. By detecting the gamma ray spectrum, the specific source material can be easily identified. Detection can be registered as a spectral continuum or more simply in properly chosen discreet energy bins. Detectors and associated electronics that register radiation in specific energy windows are commercially available. For example, potassium 40 with an energy peak of 1.466 MEV can be readily distinguished from other isotopes and particularly from fissile materials having different energy peaks. Other naturally occurring and man-made isotopes can be distinguished in the same manner. The presence of heavy shielding (e.g., "high Z material") between the radiation source and the detector can potentially degrade and smear the characteristic spectral lines and thus lessen the usefulness of spectral identification. However, commercially acceptable, legitimately shipped naturally occurring materials, such as potassium, are likely to be uniformly distributed in the cargo containers and not deliberately shielded. Hence, some of the radiation will still reach the detector

unobstructed and will thus provide a means of detecting the associated energy spectrum and identifying signature. Man-made radiation sources also have characteristic radiation signatures and ideally will be declared on the shipping manifest to facilitate the occurrence of false positive detections.

[0032] Although the sensing component 24 employed in connection with the present invention is extremely sensitive, in part due to the long detection times and highly sensitive detector structure, massive deliberate shielding of the interior of all or part of a container 12 remains a potential concern. For such shielding to be most effective, it must contain both gamma and neutron attenuating components. Gamma attenuating materials must be very dense and of a high atomic number, such as lead or a similar dense material. On the other hand, neutron attenuating materials must be of a low atomic weight but of a large volume. The conflicting shielding requirements between gamma radiation and neutrons are impractical in terms of both the container weight and volume constraints. To meet the weight constraints, the high density shielding required for gamma radiation must be concentrated right around the fissile material. This results in a disproportionately high weight to moment of inertia ratio for the container 12. As a result, massive shielding within a container 12 can be detected by measuring the weight to moment of inertia ratio of the container 12. Any container 12 having an unusually high weight to moment of inertia ratio is likely to have deliberate shielding and can be identified for further analysis. Thus, when the measured moment of inertia varies by a predetermined deviation amount, the detection controller 30 or the master unit/master module 40 may determine that heavy shielding is being used within a particular object to be tested 12. To preclude degradation of the sensitivity of the gamma radiation sensing component 24 due to massive shielding, the present invention includes equipment (not shown) for measuring the mass and at least one but preferably three moments of inertia of each cargo container 12 at the port of embarkation, prior to loading the container 12 onto the container ship. Thus, measurement of a threshold mass/moment of inertia concentration can be considered to be a probable detection of a false negative condition.

[0033] Alternatively, a rotational inertia test may be performed on each container 12 being shipped. The rotational inertia test comprises simply raising one or more edges of the container 12 and measuring the movement and/or acceleration for a given lifting force. The test may be performed along one or more axes. The density of any shielding material may be determined using a simple algorithm along with the measured test data and the total weight of the container 12. The calculation provides an indication of how concentrated the total weight of the container 12 may be—a concentrated weight may be high density shielding (i.e., "high Z material" or the like). Thus, when the measured rotational inertia varies by a predetermined deviation amount, the detection controller 30 or the master unit/master module 40 may determine that heavy shielding is being used within a particular object to be tested 12. This technique may be used to test for false negation in detection systems used for ship borne containers, trucks, cars, airline cargo containers and in almost any other shipping environments or non-shipping environment in which details of the contained material may be obscured from observation or might not otherwise be available.

[0034] Performance of the present invention can be further enhanced by utilizing information from the shipping manifest and from other sources relating to the type of contents, the shipper, the destination, prior history of the cargo, etc. in combination with the gamma radiation sensing component 24 and related components. One example of the use of such information relates to the manifest of man-made radioactive sources or a threshold concentration of high density as discussed above. The combination of data from the present invention along with information from other sources 222 (FIG. 7) improves the probability of the detection of fissile material and minimizes the probability of false positives or false negatives. Thus, the present invention includes provisions for merging data from various additional sources 222 to improve true positive detection and to minimize false positives or false negatives. False negatives, as used herein, include missing a container 12 having nuclear material therein because the sensitivity threshold is too stringent.

[0035] A neutron detector or any other suitable sensor could be employed instead of or in addition to the gamma radiation sensing component 24. If a neutron detector is used in conjunction with the gamma radiation sensing component 24 both types of emissions would be measured with the measured information being provided on separate channels or multiplexed over a single channel. In addition, the gamma radiation sensing component 24, neutron detector and/or other sensor would have self diagnostics to periodically confirm proper functionality and to provide an indication of any potential tampering and/or damage. The lack of an appropriate output signal from a gamma radiation sensing component 24, neutron detector or other sensor would suggest that the associated container 12 could be suspect.

[0036] The transmitter 26 is adapted to receive the output signal from the gamma and/or neutron radiation sensing component 24 and to transmit the signal in a manner well known to those of ordinary skill in the art. Preferably, the transmitter 26 is of the radio frequency type. However, it will be appreciated by those of ordinary skill in the art that the transmitter 26 may be of some other type such as an infrared or acoustic transmitter. Alternatively, the transmitter 26 may be of a type used in connection with satellite transmissions and/or a type used with cellular telephones. Alternatively, the transmitter 26 may use a spread spectrum or other efficient commercial communications method to facilitate transmission to and/or from a plurality of transmitters 26 arranged in an array, a matrix, a cluster and the like. Alternatively, the transmitter 26 may be a part of a transceiver, with the capability of sending as well as receiving signals. Any received signals would be routed to the controller 30 for execution of the received commands. The precise type of transmitter 26 employed should not be considered to be a limitation on the present invention. Preferably, the transmitter 26 includes a built in antenna or other transmitting element. Alternatively, a separate antenna (not shown) may be employed.

[0037] The identification component or ID tagger 28 is also connected to the transmitter 26 for the purpose of transmitting identification information. Preferably, each sensor apparatus 20 can be uniquely identified utilizing the identification component 28 in combination with the transmitter 26. The identification component 28 may use any of a variety of techniques including the use of a particular transmitter frequency, the use of digital identification tech-

niques or the like. Accordingly, the particular techniques or technology used by the identification component 28 should not be considered to be a limitation on the present invention.

[0038] A location component or location tagger 32 is also included to permit identification of the physical location of the sensor 20. Again, any standard technique or device known to those skilled in the art may be employed for performing the functions of the location component 32. Location information from the location component 32 is also transmitted by the transmitter 26. Alternatively, the location information may be input to the receiver station (FIG. 3) by bar coding or other means as would be recognized by one skilled in the art.

[0039] The controller 30 is employed for controlling the operation of the gamma radiation sensing component 24, the transmitter 26, the identification component 28 and the location component 32. The controller 30 may be a micro-processor, ASIC, or any other suitable known controlling device which has been programmed with software or firmware for providing the necessary control signals to the other components within the sensor apparatus 20. For example, in one embodiment, the controller 30 may control the timing of the transmission by the transmitter 26 of the identification information and/or the information received from the gamma radiation sensing component 24. Moreover, the controller 30 may control the operation of the other components to minimize battery life. Other control schemes or techniques will be apparent to those of ordinary skill in the art.

[0040] The power source 34 is preferably a self contained, battery which contains sufficient energy to power the other components within the sensor apparatus 20 for at least the transit time of the container ship 100. Preferably, the battery is of the rechargeable type. However, non-rechargeable batteries may alternatively be employed. The power source 34 also includes the necessary protection circuitry for the battery including a voltage regulator, short circuit protection, etc., as well as the necessary circuitry for recharging the battery. Although in the presently preferred embodiment a battery is employed as the primary power source, it will be appreciated by those of ordinary skill in the art that other power sources may be employed such as solar cells or the like. It will also be appreciated by those of ordinary skill in the art that external power may be supplied to the sensor apparatus 20 on a periodic basis to permit a form of "burst" transmission of the data obtained by the gamma radiation sensing component 24. Accordingly, it will be appreciated by those of ordinary skill in the art that any suitable power source may alternatively be employed.

[0041] As previously stated, the housing 22 containing the various components of the sensor apparatus 20 is adapted to be secured to a container 12. FIG. 1 illustrates a container in which three separate sensor apparatuses 20 are secured at three spaced locations on different sides of the container 12. In particular, a first sensor apparatus 20 is secured to a first side panel of the container approximately one third of the distance from a first end, a second sensor apparatus is secured to an end panel of the container 12 and a third sensor apparatus 20 is secured to a top panel of the container 12 approximately one third of the distance from the second end of the container 12. Alternatively, the first and third sensor apparatuses 20 can be affixed on the same side of the

container. By positioning the three sensor apparatuses **20** in this manner, complete coverage of the interior of the container **12** and the surrounding vicinity may be obtained. It will be appreciated by those skilled in the art that a lesser or greater number of sensor apparatuses **20** may be used for a container **12**, for example, one for each container **12**. Additionally, a single sensor apparatus **20** may be used for detecting the presence of nuclear material in two or more containers.

[0042] As discussed above, the primary concept of the present invention involves detecting the presence of radioactive or nuclear material within a container **12** during transit to take advantage of a longer detection time and to prevent entry of any nuclear or radioactive material into a country or port. To achieve this result, a receiver station **40** is provided. The receiver station **40** is preferably located on the container ship **100**. However, it will be appreciated by those of ordinary skill in the art that the receiver station **40** may be at some other location, such as a land-based location, if desired. All that is necessary is that the receiver station **40** have the ability to receive signals from the transmitter **26** of each sensor apparatus **20** within a container ship **100** either directly or indirectly such as through a satellite link or the like.

[0043] As best shown in FIG. 3, the receiver station **40** includes a receiver **42**, a decoder **44** and an information processing system **46**. The receiver **42** is preferably of the same type as the transmitter **26** so that the receiver **42** is capable of receiving signals transmitted by the transmitter **26** of each sensor apparatus **20**. Preferably, the receiver **42** includes a built in antenna or, alternatively, a separate antenna (not shown) may be provided. The receiver **42** receives and demodulates signals received from the transmitter **26** for each of the sensor apparatuses **20**. However, special purpose processors may be used as well. The demodulated signals are then fed to a decoder **44** which is also of a type known to those of ordinary skill in the art. The decoder **44** effectively decodes the received signals and converts them to a digital format, sending them to the information processing system **46**. In the present embodiment, the information processing system is a personal computer which includes suitable software to permit analysis of the information signals received from each of the sensor apparatuses **20**. Preferably the information processing system **46** includes a database which is keyed to each individual sensor apparatus **20** utilizing the identification information provided by the identification component **28** of each sensor. The received information creates a background radiation space. Preferably, the information system **46** receives and stores in the database the information obtained from the gamma and neutron radiation sensing component **24** of each sensor apparatus **20**. Alternatively, a command center **220** (FIG. 7) receives and stores a database of the information obtained from each sensor apparatus **20** and/or for each information system **46**. The received information from each sensor apparatus **20** permits the information system **46**, over time, to make adjustments for background or cosmic radiation to facilitate the identification of anomalies or unusual data which is likely to indicate the presence of radioactive material. Software available within the information processing system **46** analyzes the received information from each gamma and neutron radiation sensing component **24**, over time, for the purpose of determining background radiation and any such anomalies which could indicate the presence of

radioactive or nuclear material. Typically, the entire set of sensor apparatuses **20** will measure the sum of any signal due to radioactive cargo and the background radiation at each sensor location. The background radiation level can be determined to high accuracy at each sensor location by fitting smooth curves to the radiation curve measured throughout the matrix of containers or objects to be tested and the associated sensor apparatuses **20** attached thereto which thereby creates the aforementioned background radiation space. Deviation in radiation count at any detector or sensor apparatus **20** over the smoothed background radiation level for that position are indications of local radioactivity. If the presence of radioactive or nuclear material is detected, the information processing system **46** transmits an alarm signal either to personnel on board the container ship **100** or to a central facility utilizing an indication output or transmitter **48**. The indication output **48** may be a cellular phone, satellite radio, Internet connection, or any other suitable device which may be employed for transmitting the alarm signal to the desired location. The information processing system **46** also includes software which uses information from the location component **32** to identify the particular location on the container ship **100** where a sensor apparatus **20** detects the presence of radioactive material using the three dimensional container matrix **14**. In this manner, identification of a particular container **12** which may contain radioactive material is facilitated. Transmitter **48** may also have the capability of transmitting command signals to component **26** attached to container **20**, if the embodiment of component **26** is a transceiver. Thus, the master unit/master module **40** may be a monitoring device or a controlling device.

[0044] It will be appreciated by those of ordinary skill in the art that while a particular preferred embodiment of a system for detecting the presence of radioactive material within a ship board container **12** has been described, the basic concepts of the present invention are applicable in other environments. For example, the same basic techniques and technology may be employed in sensing the presence of radioactive or nuclear material in containers **12** being shipped by other methods such as by rail, air, truck, etc. Further, the same techniques could alternatively be employed for detecting the presence of radioactive or nuclear material in a non-container environment such as non-container, bulk shipments, by merely placing sensor apparatuses **20** at various locations within, for example, the hold of a ship **100** where bulk shipments are stored for transit. Thus, it will be appreciated by those of ordinary skill in the art that one basic premise of the preferred embodiments of the present invention is to make maximum use of the transit time for the purpose of detecting the presence of radioactive material and thereby eliminate or at least minimize the need to check individual containers or bulk shipments upon arrival at a port or other location. The preferred invention may also be utilized for non-modularized bulk shipments, for example on a ship **100**, by regular loading and spacing of detector apparatuses **20** to that have larger area of detection and thus greater range of detection. If the arrays have directionality as well, locating the specific point within a larger space can be accomplished via triangulation. Location determination within a ship **100** greatly facilitates intervention. Each module would still be linked to a central relay point as before. The larger arrays would compensate for lessened regularity of the array positioning and will use

the transit time for most efficient detection a substantial improvement of detection accuracy and provide for intervention by the inspection authority during transit when flexibility of response is possible.

[0045] The whole system transmission can be made more secure by proper encoding of all communications to and from the detection apparatuses 20 and the master unit/master module 40 as well as between the master unit/master module and the control center 220 (FIG. 7) as would be known to one skilled in the art.

[0046] Each sensor or detector 24 can be calibrated during production for a particular energy spectrum response as compared to an isotopic element calibration standard. The calibration standard may also be attached or disposed on or near each sensor or detector 24 to serve as a continuous reference for comparison during measurement. Further, the sensors or detectors 24 may also be configured for field calibration or standardization as would be known in the art. Furthermore, each sensor or detector 24 can be operated with an automatic temperature calibration or compensation feature to facilitate consistent performance across a wide range of temperatures.

[0047] The cargo container monitoring system 10 described herein may be used in conjunction with, or integrated with other cargo security systems, such as chemical and biological detectors, tamper-proof security systems (so called electronic container seal or "E-seal technology") and information systems that may be used in cargo inspection systems. The cargo container monitoring system 10 as described above can also incorporate human sensor technology. For example, an acoustic sensor or microphone, an odor sensor, a motion sensor or any other type of sensor which may detect the presence of humans could be included either within the sensor housing 22 or within a separate housing. Such a sensor could function continuously or could be activated by the controller 30 or by the receiver station 40 to confirm the presence of a human stowaway or "minder" within a container 12. The detection of the presence of a human within a container 12 together with the detection of radioactive material in the container 12 provides additional confirmation of the successful use of the cargo container monitoring system 10. Thus, it is contemplated that the present invention can be used in combination with a live being detector configured to detect the presence of a live being within an object to be tested 12, like a container 12 described above.

[0048] Successful detection of nuclear weapons, fissile material or "dirty" nuclear waste material is a function of a number of variables: fissile strength, shielding of target, attenuation of target by surrounding material, area of detection device, and time available for detection. The latter variable, the time of detection, will overcome all other variables in successful detection.

[0049] The sensor apparatus 20 could also be used with a GPS system for identifying the location of a container 12, truck, or other object to be tested, etc. to which the sensor apparatus 20 may be secured. In addition, the sensor apparatus 20 itself may be used to indicate that the seal of a container has been breached.

[0050] When the present invention is implemented as a communication-linked radioactive material detection sys-

tem 200 (FIG. 7), the radioactive material detection system 200 can also be used to perform other vital and non-vital functions such as commercial GPS locating, protection against clandestine opening of the transportation unit and simple logistical information polling. The linked data can be compared to a database of manifest shipping information to identify the parties involved in the shipment of the target shipment, thus proving for rapid investigation even during transit and to resolve a target identification of legitimate cargo.

[0051] FIGS. 4-5 are a flow diagram demonstrating a transit path of a container 12 from a source to a destination. FIG. 6 is a functional diagram demonstrating custodial transfer points during transit for a container 12. As can be seen, between the original shipper and the final end user destination, there are many intermediate points where a container 12 may be tampered with or compromised along the way. Additionally, having a container 12 change ships 100 at intermediate ports may be used superficially veil the actual source or source port S from a country that may be considered a higher security threat due to terrorist activity in such a country to a country that is not considered a high security risk. One of the major vulnerabilities of trusted shippers is that they can be compromised, and therefore, by merging data from a plurality of additional sources 222 and with the cargo container monitoring system 10 the likelihood of detecting such a compromised container is greatly improved.

[0052] FIG. 7 shows that the radioactive material detection system 200 includes a cargo container monitoring system 10 and a control center 220. The cargo container monitoring system 10 includes a plurality of radioactive material detection apparatuses 20 and a master unit/master module 40. The plurality of radioactive material detection apparatuses 20 each have a wireless transmitter 26, a radiation sensor 24 configured to detect radiation over a predetermined or commanded period of time, a detection controller 30 configured to send sensed radiation to the wireless transmitter 26 for transmission and an identification tag 28 electrically coupled to one of the controller 30 and the wireless transmitter 26 and configured to provide identification data or location data to the information being transmitted by the wireless transmitter 26. The master unit/master module 40 has a receiver 42 configured to receive the wirelessly transmitted information from each of the wireless transmitters 26 of the plurality of radioactive material detection apparatuses 20, a transceiver 48 and a master controller 46 coupled to the receiver 42 and configured to send the information received from the radioactive material detection apparatuses 20 through the transceiver 48. The control center 220 is in communication with the transceiver 48 of the master unit/master module 40. The control center 220 is configured to receive data from at least one additional source 222 other than the master unit/master module 40 and to asynchronously analyze the data from the at least one additional source 222 and the information from the radioactive material detection apparatuses 20 so as to detect radioactive material in a particular container 12. The transceiver 48 communicates with the control center 220 by using one or more of a cellular system, a wireless computer network, an infrared system, an ultrasonic system, a satellite system, and a radio system.



[0053] The preferred embodiments also provide for a method of detecting radioactive material within a plurality of containers 12 using a radioactive material detection system 200. The radioactive material detection system 200 includes a cargo container monitoring system 10 and a control center 220. The cargo container 12 monitoring system includes a master unit/master module 40 and a plurality of radioactive material detection apparatuses 20. Each radioactive material detection apparatus 20 has a transmitter 26, a detection controller 30 and a radiation sensor 24 configured to detect radiation over a predetermined or commanded period of time. The control center 220 is in communication with the master unit/master module 40 and is configured to receive data from at least one additional source 222 other than the master unit/master module 40. Radiation is sensed at each radioactive material detection apparatus 20. The sensed information is received from each radioactive material detection apparatus 20 at the master unit/master module 40, over the predetermined or commanded period of time. Either the master unit/master module 40 or the command center 220 adjusts for background or cosmic radiation in order to create adjusted sensor information and to facilitate the identification of an anomaly or unusual data which is likely to indicate the presence of nuclear radioactive material. The command center 220 asynchronously analyzes the data from the at least one additional source 222 and the adjusted sensor information so as to identify an anomaly amongst the plurality of containers 12, to reduce false positives, to reduce false negatives and/or to increase a sensitivity reading.

[0054] The preferred embodiments also provide for another method of detecting radioactive material within a plurality of containers 12 using a radioactive material detection system 200. The plurality of radioactive material detection apparatuses 20 are mounted to the plurality of cargo containers 12, the total set of detection apparatuses 20 comprising an array of detector and cargo container locations. At least one of gamma radiation and neutrons are sensed in totality and/or by spectral distribution over the predetermined or commanded period of time at each radioactive material detection apparatus 20 and signals representing measured radiation are transmitted to the master unit/master module 40 which communicates the sensed data to the control center 220. The control center 220 calculates an average measured radiation level at each radioactive material detection apparatus location throughout the entire array of radioactive material detection apparatuses 20 by averaging the radiation sensed at radioactive material detection apparatuses 20 proximate to each radioactive material detection apparatus 20. The set of average values for the plurality of radioactive material detection apparatuses 20 forms a varying set of calculated estimates of background radiation space for the plurality of radioactive material detection apparatuses 20 and corresponding cargo containers 12. The control center 220 compares the measured radiation at each radioactive material detection apparatus location to the calculated estimate of background radiation at each location in order to create compared sensor information. The control center 220 then asynchronously analyzes the data from the at least one additional source 222 and the compared sensor information so as to identify an anomaly amongst the plurality of containers 12, to reduce false positives, to reduce false negatives and/or to increase a sensitivity reading.

[0055] The present invention provides for the analysis of the multiple sources of data 222 for each container 12 thereby providing each container 12 with a rating system. With the present system, there is an opportunity to make changes to the rating of a particular container 12 in transit thereby providing a dynamic rating system. Each alternate source of data 222 may contribute to increasing the rating of the particular container 12 making it subject to higher scrutiny and the possibility of taking other actions. For example, an increased rating for a particular container 12 could trigger a changed standard deviation criteria (i.e., a different sigma resulting in an increased sensitivity) for monitoring the sensed data around that container 12 using the cargo container monitoring system 10 which sensitizes the ability to detect anomalies around that container 12.

[0056] Additional sources of data 222 include active container scanning systems, container manifests, container weight, container moment of inertia in one or more dimensions, container transit histories, container source logs, container destination logs, a country of origin log, a destination country log, and a field investigation report to name a few. Other additional sources of data 222 include intelligence information about the shipper, the country of origin, the shipping route, transit country, freight forwarder, consignee, owner of the cargo and the like.

[0057] Another alternate source of data 222 could also be based on an historical database for the shippers. If there is a shipment that is outside the normal pattern of the shipper, such data may set a higher warning level for a particular container 12. Thus, the present invention contemplates a standard shipper profile in order to identify changes in the shipping methods, sources, destinations, manifests and the like for those profiled shippers.

[0058] Yet another alternate source of data 222 includes evidence that the container was opened en route by detection of tampering of the container doors (e.g., "E-seal" systems). Preferably, the tampering detection is also remotely monitored during transit so that data can be merged with the other data in the control center 220 and appropriate action can be taken such as increasing the sensitivity of the cargo container monitoring system 10.

[0059] Asynchronous data analysis en route or in transit obviously enables other steps to potentially be taken such as increasing the sensitivity of the transitory monitoring of the containers 12, conducting field investigations of the shippers, conducting physical inspections of the container in question and the like. The key is being able to intervene and take action before the questionable container 12 has arrived in the destination port D.

[0060] Combining active scanning data with the cargo container monitoring system 10 makes the data from such active scanning more timely. The actively scanned images are either interpreted by a human operator or alternatively, the data is stored as an electronic image which may be interpreted using image recognition software. In the case of the human interpretation, results may not be sent to the control center 220 until after ship 100 has departed from the source port S, but preferably before the container 12 arrives at the destination port D. Instead of having to temporarily store the containers 12, action can be taken en route. FIG. 8 is a graphic demonstrating a general asynchronous analysis in accordance with the preferred embodiments of the present

invention as compared with the time for inspection, analysis and queue of an active scanning system functioning alone. Both methods would require a transit time, but by merging the data at the control center **220** the transit time can be utilized to analyze the actively scanned data and possibly take other actions with the cargo container monitoring system **10** during transit. Thus, the present invention supports both active and passive scanning systems in a synergistic and interactive fashion so that more timely action can be taken.

[**0061**] While described herein as combining active scanning technology with passive scanning technology, it is contemplated that passive scanning data can be combined with passive scanning data, active scanning data can be combined with active data and combinations thereof along with other additional sources of data to perform asynchronous analysis of data in accordance with the preferred embodiments of the present invention.

[**0062**] From the foregoing, it can be seen that the present invention comprises an apparatus and method for asynchronously analyzing data to detect radioactive material within a sealed container which is within a vessel while the container is in transit from one location to another. It will be appreciated by those skilled in the art that changes could be made to the embodiments described above without departing from the broad inventive concept thereof. It is understood, therefore, that this invention is not limited to the particular embodiments disclosed, but it is intended to cover modifications within the spirit and scope of the present invention as defined by the appended claims.

**1.** A radioactive material detection system comprising:

a cargo container monitoring system having a radiation sensor configured to detect radiation over a predetermined or commanded period of time and a transceiver configured to send the information received from the radiation sensor; and

a control center in communication with the transceiver of the cargo container monitoring system, the control center being configured to receive data from at least one additional source other than the cargo container monitoring system and to asynchronously analyze, during transit, the data from the at least one additional source and the information from the radiation sensor, so as to detect potential radioactive material in a cargo container.

**2.** The radioactive material detection system of claim 1, wherein the at least one additional source includes one of active container scanning systems, container manifests, container weight, container moment of inertia in one or more dimensions, container transit histories, container source logs, container destination logs, a country of origin log, a destination country log, and a field investigation report.

**3.** The radioactive material detection system of claim 1, wherein the transceiver communicates with the control center by using one of a cellular system, a wireless computer network, an infrared system, an ultrasonic system, a satellite system, and a radio system.

**4.** The radioactive material detection system of claim 1, wherein the at least one additional source includes intelligence information about the shipper, the country of origin, the shipping route, transit country, freight forwarder, consignee, owner of the cargo, manifest, and history of shipper.

**5.** The radioactive material detection system of claim 1, wherein the at least one additional source includes an apparatus that measures one of rotational inertia properties and moment of inertia properties of the cargo container.

**6.** The radioactive material detection system of claim 1, wherein the cargo container monitoring system also monitors at least one of temperature data, tamper detection data, odor data, sound data and motion sensor data.

**7.** The radioactive material detection system of claim 1, further comprising a dynamic rating system for each container that is updated during transit based upon the asynchronously analyzed data.

**8.** The radioactive material detection system of claim 1, wherein the cargo container monitoring system utilizes spectral data collected by the radiation sensor to identify naturally occurring or manmade radioisotopes and eliminates the naturally occurring or manmade radioisotopes to distinguish between naturally occurring or manmade material and fissile material.

**9.** A method of detecting radioactive material within a cargo container, the method comprising:

detecting radiation using a cargo container monitoring system having a radiation sensor;

sending information received from the radiation sensor to a control center in communication with the cargo container monitoring system;

receiving, at the control center, data from at least one additional source other than the cargo container monitoring system; and

asynchronously analyzing, during transit of the cargo container, the data from the at least one additional source and the information from the radiation sensor so as to detect potential radioactive material in the cargo container.

**10.** The method according to claim 9, further comprising:

upon a potential detection of radioactive material, taking action during transit of the cargo container.

**11.** The method according to claim 10, wherein the action during transit includes at least one of intercepting the cargo container before arrival, conducting a field investigation of a shipper of the cargo container, conducting a physical inspection of the cargo container, performing an active scan on the cargo container, increasing a warning level for the cargo container and increasing sensitivity of monitoring of the cargo container.

**12.** The method according to claim 9, wherein the radiation detecting includes active scanning.

**13.** The method according to claim 12, wherein the radiation detecting includes interpreting the data acquired by the active scan during transit.

**14.** The method according to claim 9, wherein the radiation detecting occurs over a predetermined or commanded period of time.

**15.** The method according to claim 9, wherein transit of the cargo container includes at least one of over-water shipping, over-land hauling, air transport and train/rail transport.

**16.** The method according to claim 9, wherein transit of the cargo container includes unloading one of a ship, a truck, a train and an airplane.

17. The method according to claim 9, wherein the asynchronous analyzing occurs during one of queuing, loading and unloading.

18. The method according to claim 9, wherein the at least one additional source includes an apparatus that measures one of rotational inertia properties and moment of inertia properties of the cargo container.

19. The method according to claim 9, wherein the at least one additional source includes one of container manifests, container weight, container moment of inertia in one or more dimensions, container transit histories, container source logs, container destination logs, a country of origin log, a destination country log, and a field investigation report.

20. The method according to claim 9, wherein the at least one additional source includes intelligence information about the shipper, the country of origin, the shipping route, transit country, freight forwarder, consignee, owner of the cargo, manifest, and history of shipper.

21. The method according to claim 9, wherein the at least one additional source includes detecting physical tampering of the cargo container.

22. A radioactive material detection system comprising:

a cargo container monitoring system having a radiation sensor that detects the presence of radioactive material in a cargo receptacle;

an inertia test apparatus configured to detect mass and inertia data of the cargo receptacle; and

a control center in communication with the cargo container monitoring system to receive radiation data from the radiation sensor, the control center being configured to receive data from the inertia test apparatus and to asynchronously analyze, during transit, the inertia data and radiation data so as to detect potential radioactive material in a cargo container.

23. The radioactive material detection system according to claim 22, wherein the cargo container monitoring system includes at least one of an active scanner and a passive scanner.

24. The radioactive material detection system according to claim 22, wherein transit includes at least one of queuing, loading, shipping and unloading.

25. The radioactive material detection system according to claim 22, wherein the inertia test apparatus is integrated into a lifting device.

26. The radioactive material detection system according to claim 22, wherein the inertia test apparatus measures at least one of rotational inertia and moment of inertia.

27. A method of detecting radioactive material within a cargo container, the method comprising:

receiving, at a control center, sensed information about the cargo container from a cargo container monitoring system having a radiation sensor configured to detect radiation over a predetermined or commanded period of time;

receiving, at the control center, data about the cargo container from at least one additional source; and

asynchronously analyzing, at the control center, the data from the at least one additional source and the sensed information so as to identify potential radioactive material within the cargo container.

28. The method according to claim 27, further comprising:

upon identification of potential radioactive material, taking action during transit of the cargo container.

29. The method according to claim 28, wherein transit includes at least one of queuing, loading, shipping and unloading.

30. The method according to claim 27, wherein the at least one additional source includes an apparatus that measures one of rotational inertia properties and moment of inertia properties of the cargo container.

31. The method according to claim 27, wherein the at least one additional source includes one of active container scanning systems, container manifests, container weight, container transit histories, container source logs, container destination logs, a country of origin log, a destination country log, and a field investigation report.

32. A radioactive material detection system comprising:

a cargo container monitoring system having a radiation sensor configured to detect at least one of gamma spectrum and neutrons over a predetermined or commanded period of time; and

a control center in communication with the cargo container monitoring system, the control center being configured to receive data from at least one additional source other than the cargo container monitoring system and to asynchronously analyze the data from the at least one additional source and the information from the radiation sensor so as to detect potential radioactive material in a cargo container.

33. The radioactive material detection system of claim 32, wherein the at least one additional source includes one of active container scanning systems, container manifests, container weight, container moment of inertia in one or more dimensions, container transit histories, container source logs, container destination logs, a country of origin log, a destination country log, and a field investigation report.

34. The radioactive material detection system of claim 32, wherein the cargo container monitoring system communicates with the control center by using one of a cellular system, a wireless computer network, an infrared system, an ultrasonic system, a satellite system, and a radio system.

35. The radioactive material detection system of claim 32, wherein the at least one additional source includes intelligence information about the shipper, the country of origin, the shipping route, transit country, freight forwarder, consignee, owner of the cargo, manifest, and history of shipper.

36. The radioactive material detection system of claim 32, wherein the at least one additional source includes an apparatus that measures one of rotational inertia properties and moment of inertia properties of the cargo container.

37. The radioactive material detection system of claim 32, wherein the cargo container monitoring system also monitors at least one of temperature data, tamper detection data, odor data, sound data and motion sensor data.

38. The radioactive material detection system of claim 32, further comprising a dynamic rating system for each container that is updated based upon the asynchronously analyzed data.

39. The radioactive material detection system of claim 32, wherein the cargo container monitoring system utilizes spectral data collected by the radiation sensor to identify naturally occurring or manmade radioisotopes and elimi-

nates the naturally occurring or manmade radioisotopes to distinguish between naturally occurring or manmade and fissile material.

40. A method of detecting radioactive material within a cargo container, the method comprising:

detecting radiation using a cargo container monitoring system having a radiation sensor that detects one of gamma spectrum and neutrons;

sending information received from the radiation sensor to a control center in communication with the cargo container monitoring system;

receiving, at the control center, data from at least one additional source other than the cargo container monitoring system; and

asynchronously analyzing the data from the at least one additional source and the information from the radiation sensor so as to detect potential radioactive material in the cargo container.

41. The method according to claim 40, further comprising:

upon a potential detection of radioactive material, taking intervening action regarding the cargo container.

42. The method according to claim 41, wherein the intervening action includes at least one of intercepting the cargo container, conducting a field investigation of a shipper of the cargo container, conducting a physical inspection of the cargo container, performing an active scan on the cargo container, increasing a warning level for the cargo container and increasing sensitivity of monitoring of the cargo container.

43. The method according to claim 40, wherein the radiation detecting includes active scanning.

44. The method according to claim 43, wherein the radiation detecting includes interpreting the data acquired by the active scan.

45. The method according to claim 40, wherein the radiation detecting occurs over a predetermined or commanded period of time.

46. The method according to claim 40, wherein the asynchronously analyzing of the cargo container occurs during at least one of over-water shipping, over-land hauling, air transport and train/rail transport.

47. The method according to claim 40, wherein the asynchronously analyzing of the cargo container occurs during unloading one of a ship, a truck, a train and an airplane.

48. The method according to claim 40, wherein the asynchronously analyzing of the cargo container occurs during one of queuing, loading and unloading.

49. The method according to claim 40, wherein the at least one additional source includes an apparatus that measures one of rotational inertia properties and moment of inertia properties of the cargo container.

50. The method according to claim 40, wherein the at least one additional source includes one of container manifests, container weight, container moment of inertia in one or more dimensions, container transit histories, container source logs, container destination logs, a country of origin log, a destination country log, and a field investigation report.

51. The method according to claim 40, wherein the at least one additional source includes intelligence information about the shipper, the country of origin, the shipping route, transit country, freight forwarder, consignee, owner of the cargo, manifest, and history of shipper.

52. The method according to claim 40, wherein the at least one additional source includes detecting physical tampering of the cargo container.

\* \* \* \* \*