



US 20070271934A1

(19) **United States**

(12) **Patent Application Publication**
Lyon

(10) **Pub. No.: US 2007/0271934 A1**

(43) **Pub. Date: Nov. 29, 2007**

(54) **AIR TREATMENT SYSTEM FOR
CONDITIONING AND PURIFYING THE AIR
OF A VEHICLE CABIN**

Publication Classification

(51) **Int. Cl.**
F25D 17/06 (2006.01)

(75) **Inventor: Roland Lyon, Couture sur le Loir (FR)**

(52) **U.S. Cl.** **62/94**

Correspondence Address:
WESTMAN CHAMPLIN & KELLY, P.A.
SUITE 1400
900 SECOND AVENUE SOUTH
MINNEAPOLIS, MN 55402-3319 (US)

(57) **ABSTRACT**

The disclosure relates, in particular to an evaporating air conditioner for cabins of vehicles or the similar comprising an evaporation chamber provided with a water mister arranged therein and an injector for injecting air into said evaporation chamber in such a way that it is directed towards the cabin by an air output and passes through at least one humid filter. The inventive air conditioner includes deflectors converging said injected air and said water mist towards a runoff mounted near said humid filter in such a way that water droplets produced from said water mist are directed towards the filter surface which is oriented inside of the evaporation chamber and flow thereon.

(73) **Assignee: AereI, Besse-sur-Braye (FR)**

(21) **Appl. No.: 10/588,832**

(22) **PCT Filed: Feb. 3, 2005**

(86) **PCT No.: PCT/FR05/00235**

§ 371(c)(1),
(2), (4) **Date: May 14, 2007**

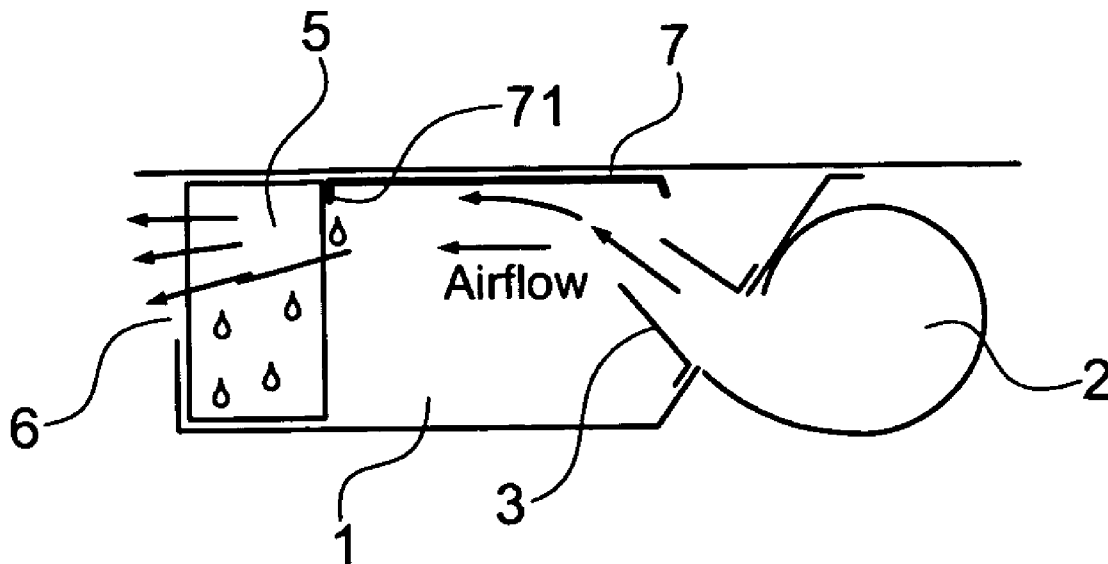

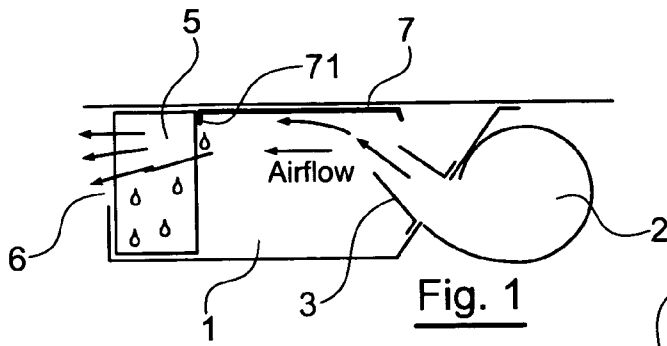

Fig. 1

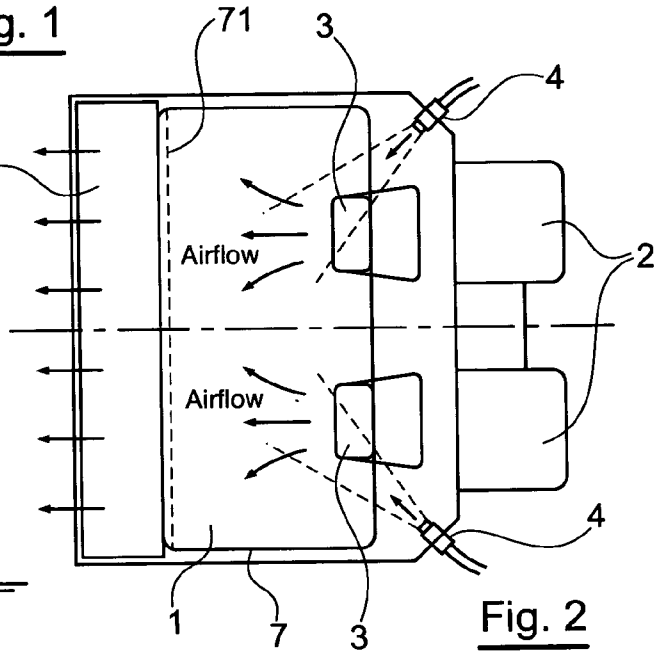

Fig. 2

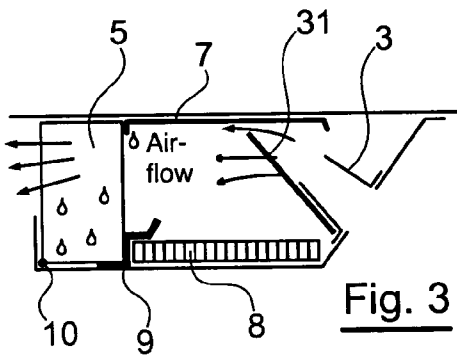

Fig. 3

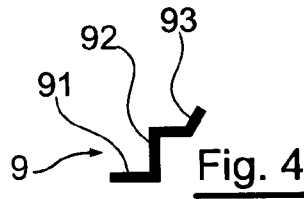

Fig. 4

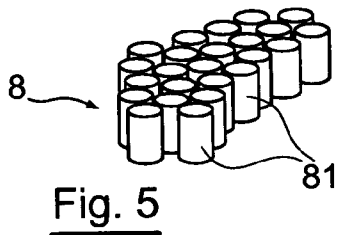

Fig. 5

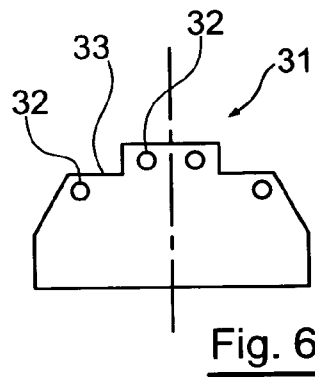

Fig. 6

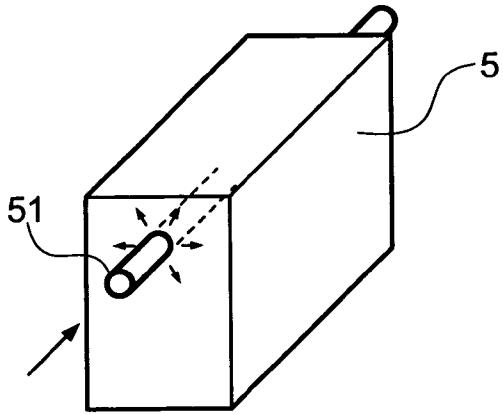

Fig. 7

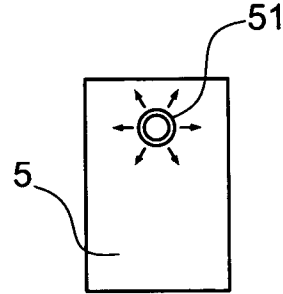

Fig. 8

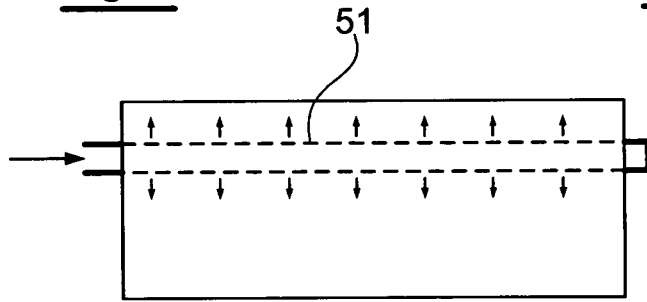

Fig. 9

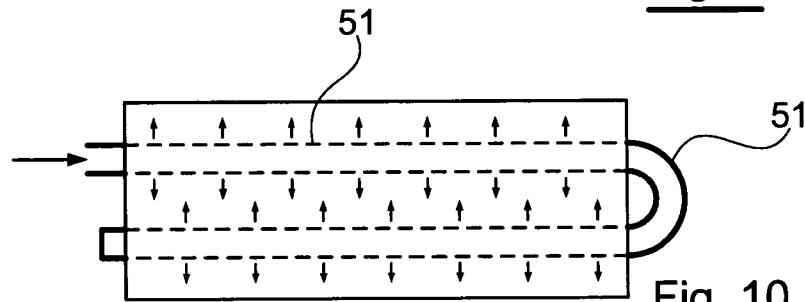

Fig. 10

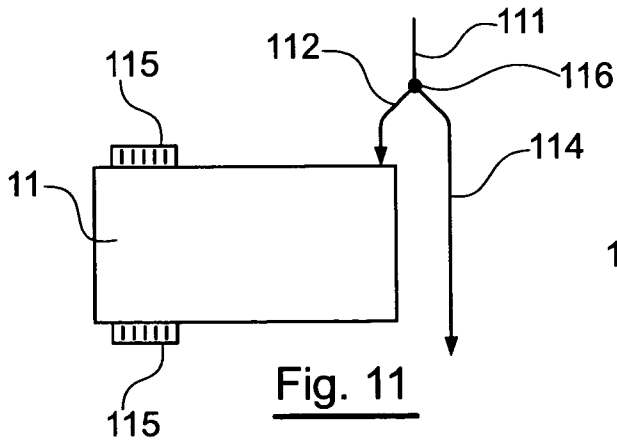

Fig. 11

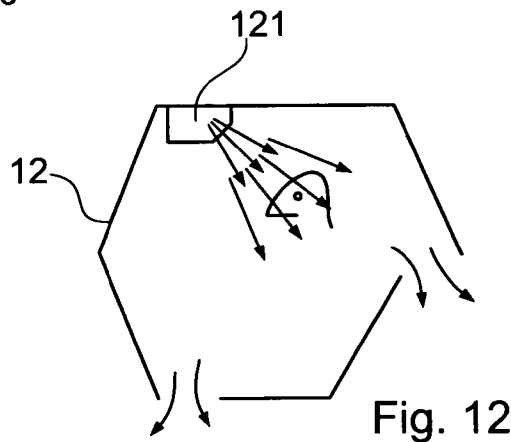

Fig. 12

AIR TREATMENT SYSTEM FOR CONDITIONING AND PURIFYING THE AIR OF A VEHICLE CABIN

CROSS-REFERENCE TO RELATED APPLICATION

[0001] This Application is a Section 371 National Stage Application of International Application No. PCT/FR2005/000235, filed Feb. 3, 2005, and published as WO 2005/082654 on Sep. 9, 2005, not in English.

FIELD OF THE DISCLOSURE

[0002] The disclosure relates to the field of air treatment devices associated with vehicle cabins. More precisely, the disclosure relates to a filtering air conditioner designed to equip the cabin of a vehicle.

BACKGROUND

[0003] The term vehicle is understood to mean all vehicles including agricultural vehicles, construction vehicles, industrial vehicles, or others.

[0004] Water evaporative air conditioners conventionally comprise an annular evaporation chamber, means of drawing in the outside air and dampening or humidifying means inside the chamber. These humidifying means generally consist of a rotating disk or injectors that spray water into the chamber, producing droplets the size of which may vary. In this way, a fine rain or mist (hereinafter in the description, the terms "mist" or "rain" or "sprayed water" will be used with differentiation).

[0005] The principle of this type of air conditioner consists in obtaining an evaporation phenomenon, which is accompanied by a cooling of the air that is intended to be pulsed into the cabin.

[0006] Another type of water evaporative air conditioner is described by the patent EP0027760 filed under the same name as this application.

[0007] According to the technique described, the air conditioner includes an evaporation chamber into which opens out a distribution chamber for the air pulsed by a turbofan. At the end of the chamber opposite the air intake is placed an eliminator medium through which the air passes in order to reach the cabin.

[0008] A solution such as this has made it possible to propose more compact air conditioners while at the same time providing satisfactory cooling of the air.

[0009] However, treating the air with such air conditioners does not involve purification of the air.

[0010] Such being the case, in certain applications of the invention, the vehicle is placed in a hostile atmosphere and the air drawn in by the air conditioner may be laden with dust, aerosols, fumes or various gases.

[0011] This is the case, for example, of tractors and agricultural vehicles when crops are being sprayed with phytosanitary treatments, or of vehicles working in quarries.

[0012] Thus, it is desirable that the air delivered into the cabin of a vehicle might not only be conditioned but also purified, when the air in question is drawn in from outside

of the cabin. It is also necessary to ensure quality control of the air breathed in, i.e., the atmosphere inside of the passenger compartment.

[0013] Conventionally, this dual problem (air conditioning+purification) is approached in terms of the treatment of a cubic capacity, by the association of an airtight cabin with a refrigerating air conditioner and filters at its air intake. The disadvantage of this system is that respiratory protection of the operator becomes faulty, on the one hand, when the cabin is not or is no longer sealed and, on the other hand, by the internal recycling of the air involved in this type of air conditioning.

SUMMARY

[0014] An embodiment of the disclosure relates to a water evaporative air conditioner for vehicle cabins and the like, of the type including an evaporation chamber in which mist-forming means are provided, air being delivered into said evaporation chamber with a view to being directed towards said cabin via an air outlet, while passing through at least one wet filter, including deflector means making it possible to cause said delivery air and said mist to converge towards run-off means provided in the vicinity of said wet filter, with the result being that the droplets of water formed by the mist are directed towards the surface of said filter facing the inside of said evaporation chamber, and run off over this surface.

[0015] In this way, thanks to an embodiment of the invention, the air-conditioning and air purification functions are carried out simultaneously by a single device. As a matter of fact, the cooled air in contact with the mist of water impacts the wet filter, which thus acts also as an impact and coalescing filter, the air thereby being rid of its impurities, such as liquid or solid aerosols.

[0016] These functions are ensured in a reliable and long-lasting manner by implementing the run-off means according to an embodiment of the invention, these means making it possible to clean the surface of the filter as a result of the run-off produced.

[0017] Moreover, the wetting of the filter is accomplished almost irrespectively of the tilt and vibrations of the assembly, which guarantees performance levels that would not be obtainable with a drip gutter or mere gravity.

[0018] It is noted that an embodiment of the invention proposes a technique according to which the air conditioning and purification are carried out by the same functional unit, which constitutes a notable change in comparison with the prior art.

[0019] As a matter of fact, conventional air-conditioning systems do not provide the purification function by themselves. Therefore, an air filtration device is most often associated with them. In practice, it is recognized that the purification function may be subject to malfunctioning, possibly to the point of presenting health hazards (e.g., in the case the salting out of an active carbon filter), or perhaps be quite simply absent from the equipment. The purification function is made faulty by the recycling of the inside air, as soon as the quality of this airflow is not controlled.

[0020] In contrast, the air that is pulsed into the cabin with the aid of the air conditioner is, in this case, both systematically cooled and purified.

[0021] In addition, owing to the principle of evaporative air conditioning, open-cycle operation is possible (i.e., without recycling the air), which enables maximum pressurization of the cabin. In this way, any direct intake of outside air into the cabin is prevented (the air pulsed into the cabin coming entirely from the air treatment system). Furthermore, it is not necessary to make the cabin airtight, as is most often the case with the devices of the prior art.

[0022] In other words, operation occurs using purified air coming exclusively from the air conditioner, without any recirculation of air coming from the cabin.

[0023] According to one preferred solution, said wet filter is made of a hydrophilic material.

[0024] A filter thus made fulfills several functions simultaneously: that of a humidifying medium, that of an impact and coalescing filter and that of a wet filter.

[0025] According to one advantageous solution, said run-off means include at least one impact lip for said droplets, extending into the upper portion of said wet filter in a plane substantially coincident with the plane of said surface of said filter turned towards the inside of said chamber.

[0026] An internal architecture for the air conditioner such as this proves to be easy to implement and inexpensive to produce.

[0027] Said lip is preferentially formed by a fold made in a plate, referred to as a drop-out plate, fastened beneath a cover for closing said evaporation chamber.

[0028] A simply designed solution is obtained, the assembly of which can be easily and quickly accomplished.

[0029] In this case, said drop-out plate advantageously has a raised portion or profile designed to evenly distribute the water over said lip.

[0030] The run-off is thus optimized, which ensures that the face of the filter turned towards the inside of the evaporation chamber is evenly washed.

[0031] Advantageously, the device includes a deflector plate running in line with a delivery air distribution box.

[0032] In this way, proper diffusion of the air is ensured so as to cause it to impact the run-off means, and more particularly the inside face of the plate fastened beneath the cover.

[0033] In this case, said deflector plate advantageously contains perforations and/or a cut-out section in its upper edge.

[0034] In this way, control is exercised over:

[0035] the cross-wise distribution of the airflow;

[0036] the shear rates of the air;

[0037] the wetness distribution of the filter (as mentioned previously).

[0038] According to one particular embodiment, said mist-forming means include at least one injector positioned in relation to said deflector means such that said injector or injectors expel the water in a direction that, in the area of said run-off means, converges with the airflow at the outlet of said deflector means.

[0039] The mist spray cone is thus optimally pointed so as to converge with the flow of air towards the inside face of the drop-out plate.

[0040] Advantageously, said chamber includes at least two drain-off points for the condensed water, which are paired with extracting means.

[0041] In this way, an effective drain-off of the condensed water is obtained, which, for example, can be carried out with the aid of a pump (or several pumps) associated with water filtering means.

[0042] The amount of stagnant water is thereby minimized. Furthermore, in this way, an almost complete and continuous drain-off of the condensed water is ensured.

[0043] According to one preferred solution, said chamber has a bottom provided with lining means including at least one of the means belonging to the following group:

[0044] covering with a material including a plurality of tubes joined to one another or intercommunicating cells;

[0045] a profiling having water pass-through means.

[0046] An arrangement such as this makes it possible to work under nearly any circumstances as regards tilting, vibrations and length of use.

[0047] As a matter of fact, the amounts of condensed water are "trapped" by the liner provided at the bottom of the chamber, which makes it possible to eliminate or, at the very least, limit the wave effects during abrupt changes in tilt.

[0048] The condensed water is then gradually released by arriving in a space formed between the liner and the bottom of the evaporation chamber.

[0049] According to a first alternative, a pad made of a soft foam material is interposed between said covering and the bottom of said chamber.

[0050] According to a second alternative, the profiling has at least one of the means belonging to the following group:

[0051] a water pass-through opening;

[0052] a space formed in relation to the bottom and/or walls of said chamber;

[0053] an upper lip extending said profiling.

[0054] In either case (or both combined), the transfer rate of the stagnant water is controlled, in particular during abrupt changes in tilt.

[0055] Furthermore, overly fast transfers of water are prevented, which could momentarily saturate the drain-off system.

[0056] Advantageously, said extraction means are connected to a water reservoir, and a valve makes it possible to shift between at least two configurations:

[0057] a recycling configuration in which the water recovered by said extraction means is redirected towards said reservoir;

[0058] a discharge configuration in which the water recovered by said extraction means is discharged as waste water.

[0059] The operator can thus select his mode of operation, either by using a volume of clean water (which may prove useful in the case of use in a particularly hostile environment), or by recycling the used water.

[0060] According to one particular embodiment, this device includes wetting means built into said wet filter.

[0061] In this case, said wetting means include a circulating system made of a porous material.

[0062] An embodiment of the invention also relates to a vehicle whose cabin is equipped with a water evaporative air conditioner, of the type including an evaporation chamber in which mist-forming means are provided, air being delivered into said evaporation chamber with a view to being directed towards said cabin via an air outlet, while passing through at least one wet filter, including deflector means making it possible to cause said delivery air and said mist to converge towards run-off means provided in the vicinity of said wet filter, with the result being that the droplets of water formed by the mist are directed towards the surface of said filter facing the inside of said evaporation chamber, and run off over this surface.

[0063] According to one advantageous solution, said vehicle and/or said air conditioner include means of diffusing the air coming from said air conditioner, making it possible to point at least one airflow into said cabin directly towards at least one operator position.

[0064] This is made possible by the water evaporative air conditioner according to an embodiment of the invention, whose climate control features comply with the physiological comfort requirements (temperature and humidity control) relating to the face and body of the operator.

[0065] This stands in opposition to conventional air-conditioning systems that supply air whose temperature at the outlet of the diffuser is too low to permit direct diffusion. Therefore, it is necessary to direct the airflow towards the walls of the passenger compartment and not towards the occupant.

[0066] According to one preferred solution, said vehicle and/or said air conditioner includes means of slaving the flow rate of the air coming from said air conditioner to the pressurization of said cabin, provided in such a way that the airflow rate varies inversely in relation to the variations in said pressurization.

[0067] In this way, when the cabin is open, the flow rate of the air coming from the air conditioner may be at a maximum and therefore be at a speed that makes it possible to reach the operator directly, like an air curtain or "zoning" effect.

[0068] According to another advantageous characteristic, said slaving means also act on said diffusion means so that the air is pointed towards the operator when the pressurization of said cabin decreases, and is pointed in another direction when said pressurization increases.

[0069] An embodiment of the invention also relates to a cabin designed to be mounted on a vehicle equipped with a water evaporative air conditioner, of the type including an evaporation chamber in which mist-forming means are provided, air being delivered into said evaporation chamber with a view to being directed towards said cabin via an air

outlet, while passing through at least one wet filter, including deflector means making it possible to cause said delivery air and said mist to converge towards run-off means provided in the vicinity of said wet filter, with the result being that the droplets of water formed by the mist are directed towards the surface of said filter facing the inside of said evaporation chamber and run off over this surface.

[0070] Other characteristics and advantages will become more clearly apparent upon reading the following description of a preferential embodiment and of several of its alternative embodiments, given as illustrative and non-limiting examples, and of the appended drawings.

BRIEF DESCRIPTION OF THE DRAWINGS

[0071] FIGS. 1 and 2 are respective side and top sectional views of an air conditioner according to an embodiment of the invention;

[0072] FIG. 3 is a sectional side view of an alternative embodiment of an air conditioner according to an embodiment of the invention;

[0073] FIG. 4 is a sectional side view of a profiling designed to slow down the transfers of condensed water in an air conditioner according to an embodiment of the invention;

[0074] FIG. 5 is a view of a bottom liner designed to equip an air conditioner according to an embodiment of the invention;

[0075] FIG. 6 is a front view of a deflector plate designed to equip an air conditioner according to an embodiment of the invention;

[0076] FIGS. 7 to 9 are views of a particular embodiment of a wet filter designed to equip an air conditioner according to an embodiment of the invention;

[0077] FIG. 10 is a view of an alternative to the wet filter shown in FIGS. 7 to 9;

[0078] FIG. 11 is a schematic illustration of a circulating system for returning condensed water to the water reservoir of an air conditioner according to an embodiment of the invention;

[0079] FIG. 12 is a schematic view of a cabin equipped with an air conditioner according to an embodiment of the invention, showing the airflows inside the cabin.

DETAILED DESCRIPTION OF ILLUSTRATIVE EMBODIMENTS

[0080] The device of this disclosure shall be hereinafter designated as either an "air treatment system" or an "air conditioner".

[0081] With reference to FIG. 1, a water evaporative air conditioner according to an embodiment of the invention includes:

[0082] an evaporation and air-washing chamber 1;

[0083] a turbofan 2 making it possible to pulse air into the evaporation chamber via a distribution box 3;

[0084] injectors 4 consisting of means of forming a mist inside the evaporation chamber 1;

- [0085] a wet filter **5** placed in front of the air outlet **6** of the air conditioner, by means of which the cooled and purified air is directed into the cabin of a vehicle.
- [0086] According to this embodiment of the invention, the air delivered into the chamber **1** and the mist converge towards drop-out plate **7** forming run-off means, this plate having a lip **71** in the vicinity of the wet filter **5** so that droplets formed by the mist are carried towards the surface of the filter **5** turned towards the inside of the chamber, and run-off over this surface.
- [0087] As it appears, this lip **71** extends into a plane substantially coincident with the plane of the surface of the filter **5** turned towards the inside of the chamber, while being contiguous with said surface.
- [0088] The lip **71** consists of a fold formed in the drop-out plate, the latter being fastened beneath the cover **73** of the air conditioner.
- [0089] It is noted that the run-off means just described might be formed directly inside the wall of the cover, according to another foreseeable embodiment.
- [0090] Additionally, the drop-out plate **7** has a raised portion (not shown), e.g., grooves, making it possible to distribute the water over the surface of the plate, then the lip and, as a result, the filter **5**.
- [0091] According to the embodiment shown in FIG. **3**, a deflector plate **31** is inserted beneath the distribution box **3** so as to extend the latter.
- [0092] As it appears in FIG. **6**, this deflector plate has a cut-out section **33** and openings **32**, with a view to controlling the cross-wise distribution and speed of the airflow.
- [0093] In addition, the bottom of the evaporation chamber is provided with a liner **8** consisting of tubes **81** joined to one another, as illustrated in FIG. **5**.
- [0094] Preferentially, sandwiched between the bottom of the chamber **1** and the base of the liner **8** is a pad, which may consist of an open-cell material (not shown), making it possible to control the water-flow attenuation between the bottom and the liner.
- [0095] At the base of the wet filter **5**, a contoured profiling **9** is also provided, blocking an overly rapid transfer of condensed water towards the two drain-off points **10** arranged at the base of the chamber, in the corners thereof, in the vicinity of which the filter **5** is located.
- [0096] Extraction means are associated with the drain-off points **10**. It is noted that these drain-off points may be situated level with the bottom of the chamber (and not necessarily underneath this bottom).
- [0097] The profiling **9**, as illustrated in FIG. **4**, makes it possible to slow down the transfers of condensed water in the area of the liner owing to an appropriate dimensioning of the space maintained between its walls **91**, **92** and the interior walls (bottom and sides) of the evaporation chamber, and owing to the holes provided in the wall **92** (not shown), the arrangement and diameters of which are selected for controlling the water transfer rate during tilting.
- [0098] In addition, the profiling **9** is equipped with an upper lip **93** designed to block an overly rapid transfer of free water towards the drain-off points.
- [0099] In this case, the wet filter **5** is made of a hydrophilic material.
- [0100] According to one foreseeable alternative shown in FIGS. **7** to **9**, the hydrophilic wetting is obtained by an internal delivery of water to its core: to this end, a circulating system **51** consisting of one or several lengths of tubing made of a porous material (e.g., a porous rubber hose such as is used in irrigation, or tubing made of ceramic or another porous material) passes through the filter **5**; this tubing is in contact with the hydrophilic material, in the same way as the copper tubes contained in radiators, and that are in contact with the fins.
- [0101] As shown in FIG. **9**, the circulating system **51** comprises a single branch receiving pressurized water at one of its ends and sealed at the other end.
- [0102] According to one foreseeable alternative shown in FIG. **10**, the circulating system **51** has two (or more) branches inside the filter **5**.
- [0103] The water is delivered under pressure to the interior of this circulating system made of a porous tubing; it beads through its wall, and passes into the filter medium the hydrophilic material of which ensures that it is diffused throughout its capacity.
- [0104] In reference to FIG. **11**, the injectors present inside the evaporation chamber are connected to a water reservoir **11**.
- [0105] The drain-off points for the condensed water are connected to a drain line **111**.
- [0106] A valve **116** makes it possible to choose to connect the drain line with:
- [0107] either a recycling line **112** by which the possibly pre-filtered water is returned to the reservoir;
 - [0108] or a discharge line **114** making it possible to discharge the water as waste water, which enables continuous clean water operation.
- [0109] The top plug **115** enables filling of the reservoir. The bottom plug **113** (or a valve) enables regular purging of the reservoir after work is completed, so that it is possible, at the end of the day, to discharge the residual concentrated waste water that has already been put to work and, the next day, to start again with a reservoir of fresh clean water.
- [0110] It is noted that the pumps for the injection line and purge line (drain-off) may be operated cyclically or sequentially, thereby making it possible to extend their lifespan. This is made possible, in particular, because of the hydrophilic nature of the filter **5** which, for this reason, exhibits a wetting hysteresis phenomenon between two injection cycles, and because of the device for managing the condensed water inside the air conditioner, which provides a buffer effect between two purge cycles.
- [0111] With reference to FIG. **12**, an air conditioner such as the one just described is installed on a vehicle cabin **12**.
- [0112] According to this embodiment, this cabin **12** is non-airtight, as shown schematically, and is pressurized.
- [0113] The absence of recycling, and the use of an airflow taken 100% from the outside, enables complete pressurization with 100% of the airflow involved. In this way, the

passenger compartment benefits from a maximum pressurization, which renders the cabin airtight, including with respect to localized openings (e.g., control panel pass-throughs), or the deterioration of seals.

[0114] Protection against the intake of environmental nuisances is thus ensured by insulating the passenger compartment.

[0115] The design and manufacture of the cabin can be simplified since air-tightness is obtained not by reason of its construction, but by the air pressurization.

[0116] Diffusion means 12 are provided to enable the operator to receive the airflow directly on himself, and particularly on the upper portion of the body and on the face.

[0117] It is in this way that the respiratory protection of the operator is then ensured thanks to the quality of the cooled and purified air of the flow in which the operator is directly situated.

[0118] The fact that the cabin is not closed is compensated for by the arrangement that allows the driver to benefit directly from surrounding local micro-climate, which determines the air that he breathes.

[0119] According to another characteristic, the airflow rate of the fan turbine is slaved to the pressurization of the cabin: a pressure switch or differential pressure sensor measures the relative excess pressure of the passenger compartment interior in relation to the exterior. The flow rate of the turbine is slaved such that it automatically varies inversely in relation to the pressurization: maximum flow rate for minimum pressurization, and vice-versa.

[0120] Thus, when the cabin is open, the pressurization is minimum and the airflow rate (which is then maximum) has a velocity that enables it to reach the operator directly, like an air curtain or zoning effect.

[0121] According to yet another characteristic, the output direction of the airflow is likewise slaved to the pressurization measurement, such that the flow is pointed directly on the operator when the pressurization is minimum (open cabin), and away from the operator when the pressurization is maximum (sealed cabin).

[0122] It is noted that these automatic controls are implemented according to a default operation mode; the operator may therefore establish various control settings manually. The "slaved" control settings are automatically reset when the apparatus stops.

[0123] It is recalled that the invention is not limited to the embodiment just described. As a matter of fact, the air conditioner may benefit from the improvements consisting, in particular, of:

[0124] activating the air washing by incorporating physical and/or chemical adjuvants into the water; these adjuvants may be added to the reservoir in slowly dissolving, concentrated solid or liquid form, where they blend with the water over successive fillings; these slowly dissolving, concentrated adjuvants may also be integrated into the water filter housings, which furthermore must be replaced regularly during maintenance operations (in this way, the user need not ever be concerned with renewing the adjuvant);

[0125] associating treatment of the water, e.g., by integrating a copper exchanger (fungicidal, algicidal properties . . .) and/or with the aid of radiating lamp(s) or tube(s) built into the air conditioner and/or the reservoir.

[0126] An embodiment proposes a water evaporative air conditioner that makes it possible to move about in certain hostile atmospheres and that delivers fresh and healthy air into the cabin.

[0127] An embodiment provides an air conditioner such as this, which is capable of operating effectively either when the cabin is closed or when it is open.

[0128] An embodiment provides an air conditioner such as this, which retains the advantages of prior evaporative air conditioners, in particular as concerns the management of condensed water inside the air conditioner.

[0129] An embodiment provides an air conditioner such as this, which is simple in design and easy to implement and to install on, or build into the cabin of a vehicle.

[0130] Although the present disclosure has been described with reference to preferred embodiments, workers skilled in the art will recognize that changes may be made in form and detail without departing from the spirit and scope of the invention.

1. A water evaporative air conditioner for vehicle cabins and the like, the air conditioner comprising:

an evaporation chamber, air being delivered into said evaporation chamber with a view to being directed towards said cabin via an air outlet, while passing through at least one wet filter

a mister, which delivers mist into the evaporation chamber;

a run-off provided in the vicinity of said wet filter; and

a deflector positioned to cause said delivery air and said mist to converge towards the run-off, with the result being that droplets of water formed by the mist are directed towards a surface of said wet filter facing an inside of said evaporation chamber, and run off over this surface.

2. Air conditioner of claim 1, wherein said wet filter comprises a hydrophilic material.

3. Air conditioner of claim 1, wherein said run-off includes at least one impact lip for said droplets, extending into an upper portion of said wet filter in a plane substantially coincident with the plane of said surface of said filter turned towards the inside of said chamber.

4. Air conditioner of claim 3, wherein said lip is formed by a fold made in a plate, referred to as a drop-out plate, fastened beneath a closing cover for said evaporation chamber.

5. Air conditioner of claim 4, wherein said drop-out plate has a raised portion or profile designed to evenly distribute the water over said lip.

6. Air conditioner of claim 1, and further comprising a delivery air distribution box, which delivers the air into the evaporation chamber, and wherein the deflector comprises a deflector plate running in line with the delivery air distribution box.

7. Air conditioner of claim 6, wherein said deflector plate contains perforations and/or a cut-out section in an upper edge thereof.

8. Air conditioner of claim 6, wherein said mister includes at least one injector positioned in relation to said deflector such that said at least one injector expels the water in a direction that, in the area of said run-off, converges with the airflow at an outlet of said deflector.

9. Air conditioner of claim 1, wherein said chamber includes at least two drain-off points for condensed water, which are paired with an extractor.

10. Air conditioner of claim 1, wherein said chamber has a bottom provided with a liner including at least one of the elements belonging to the following group:

a covering with a material including a plurality of tubes joined to one another or intercommunicating cells; and

a profiling having at least one water pass-through.

11. Air conditioner of claim 10, and further comprising a pad made of a soft foam material is interposed between said covering and a bottom of said chamber.

12. Air conditioner of claim 10, wherein the profiling has at least one of the elements belonging to the following group:

a water pass-through opening;

a space formed in relation to a bottom and/or walls of said chamber; and

an upper lip extending said profiling.

13. Air conditioner of claim 9, wherein said extractor is connected to a water reservoir a valve makes it possible to shift between two configurations:

a recycling configuration in which the water recovered by said extractor is redirected towards said reservoir; and

a discharge configuration in which the water recovered by said extractor is discharged as waste water.

14. Air conditioner of claim 1, and further comprising wetting means built into said wet filter.

15. Air conditioner of claim 14, wherein said wetting means include a circulating system made of a porous material.

16. A vehicle whose cabin is equipped with a water evaporative air conditioner, which comprises:

an evaporation chamber, air being delivered into said evaporation chamber with a view to being directed towards said cabin via an air outlet, while passing through at least one wet filter

a mister, which delivers mist into the evaporation chamber;

a run-off provided in the vicinity of said wet filter; and

a deflector positioned to cause said delivery air and said mist to converge towards the run-off, with the result being that droplets of water formed by the mist are directed towards a surface of said wet filter facing an inside of said evaporation chamber, and run off over this surface.

17. Vehicle of claim 16, wherein said cabin and/or said air conditioner include a diffuser, which diffuses the air coming from said air conditioner, making it possible to point at least one airflow into said cabin directly towards at least one operator position.

18. Vehicle of claim 16, wherein said cabin and/or said air conditioner include means of slaving the flow rate of the air coming from said air conditioner to a pressurization of said cabin, provided in such a way that the air flow rate varies inversely in relation to variations in said pressurization.

19. Vehicle of claim 18, wherein said cabin and/or said air conditioner include a diffuser, which diffuses the air coming from said air conditioner, making it possible to point at least one airflow into said cabin directly towards at least one operator position, and, wherein said slaving means also act on said diffuser so that the air is pointed towards the operator position when the pressurization of said cabin decreases, and is pointed in another direction when said pressurization increases.

20. A cabin designed to be mounted on a vehicle equipped with a water evaporative air conditioner, the cabin comprising:

an evaporation chamber (1) in which mist-forming means (4) are provided, air being delivered into said evaporation chamber with a view to being directed towards said cabin via an air outlet, while passing through at least one wet filter

a mister, which delivers mist into the evaporation chamber;

a run-off provided in the vicinity of said wet filter; and

a deflector positioned to cause said delivery air and said mist to converge towards the run-off, with the result being that droplets of water formed by the mist are directed towards a surface of said wet filter facing an inside of said evaporation chamber, and run off over this surface.

* * * * *