

[54] INFLATABLE LOAD SUPPORTING STRUCTURES

[72] Inventor: Walter P. Nail, 260 Renforth Drive, Etobicoke, Ontario, Canada

[22] Filed: Jan. 6, 1970

[21] Appl. No.: 885

[30] Foreign Application Priority Data

Jan. 9, 1969 Canada.....039,632

[52] U.S. Cl.....5/349, 297/284

[51] Int. Cl.....A47c 27/08

[58] Field of Search.....5/348, 349, 350, 355, 338; 297/DIG. 8, 284; 254/93 HP

[56] References Cited

UNITED STATES PATENTS

3,303,518	2/1967	Ingram	5/349
2,434,641	1/1948	Burns	5/348 X
2,245,909	6/1941	Enfajian	5/348

Primary Examiner—Bobby R. Gay
Assistant Examiner—Andrew M. Calvert
Attorney—Douglas S. Johnson

[57] ABSTRACT

The invention is an inflatable structure which has both shape and load control achieved by locating a plurality of inflatable beams columns or chambers within an outer inflatable chamber, all formed of flexible substantially non expansible (limited stretch) air impervious material, the beams columns or chambers being connected to opposed walls of the outer chamber to limit their separation and being constructed and arranged to preclude transfer of air between the interior thereof and the outer chamber in at least certain directions, the beams or columns being side by side or spaced as desired relative to each other in accordance with the intended load and the connections between the beams or columns and the opposing walls of the outer chamber including connections extending in different directions to give stability under load.

6 Claims, 9 Drawing Figures

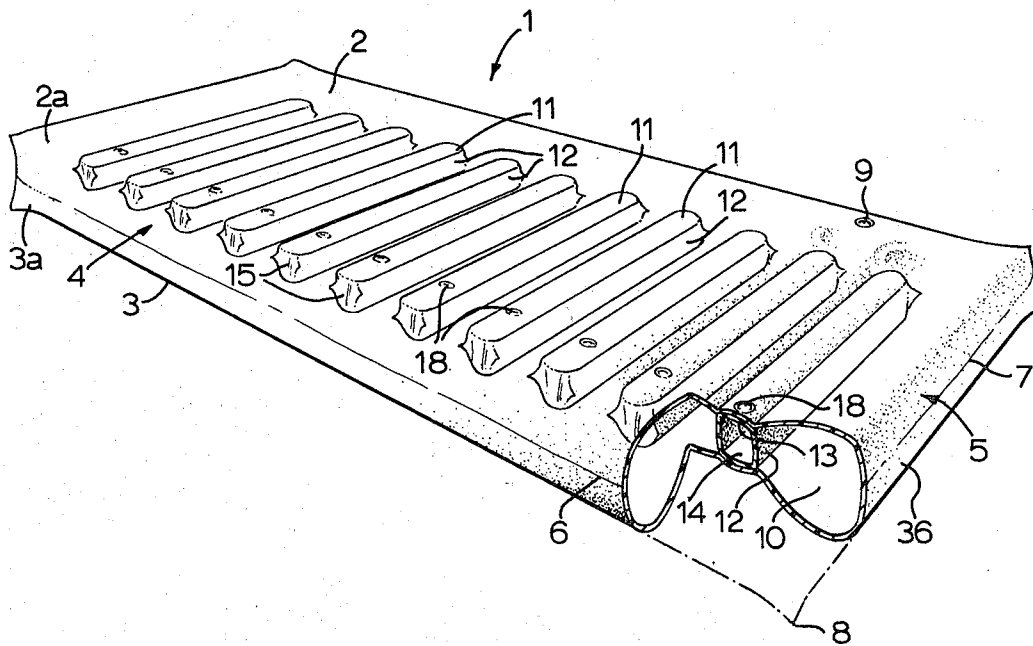

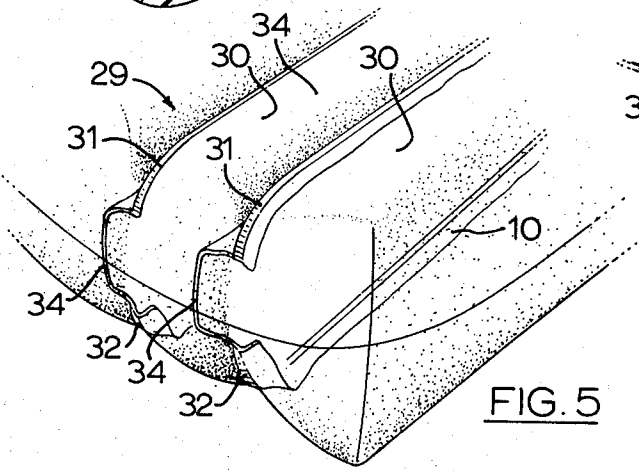
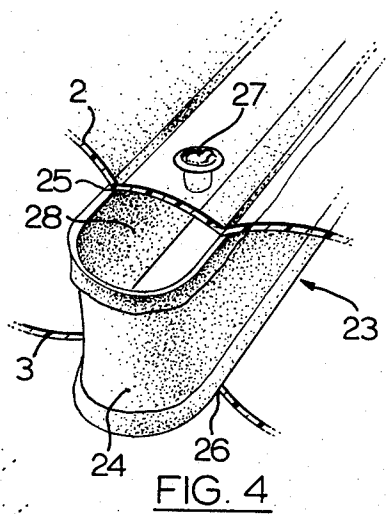
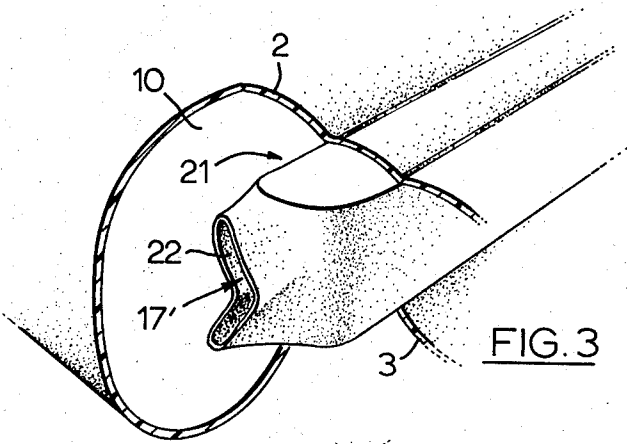
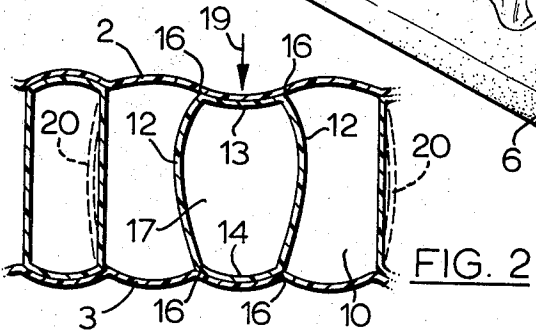
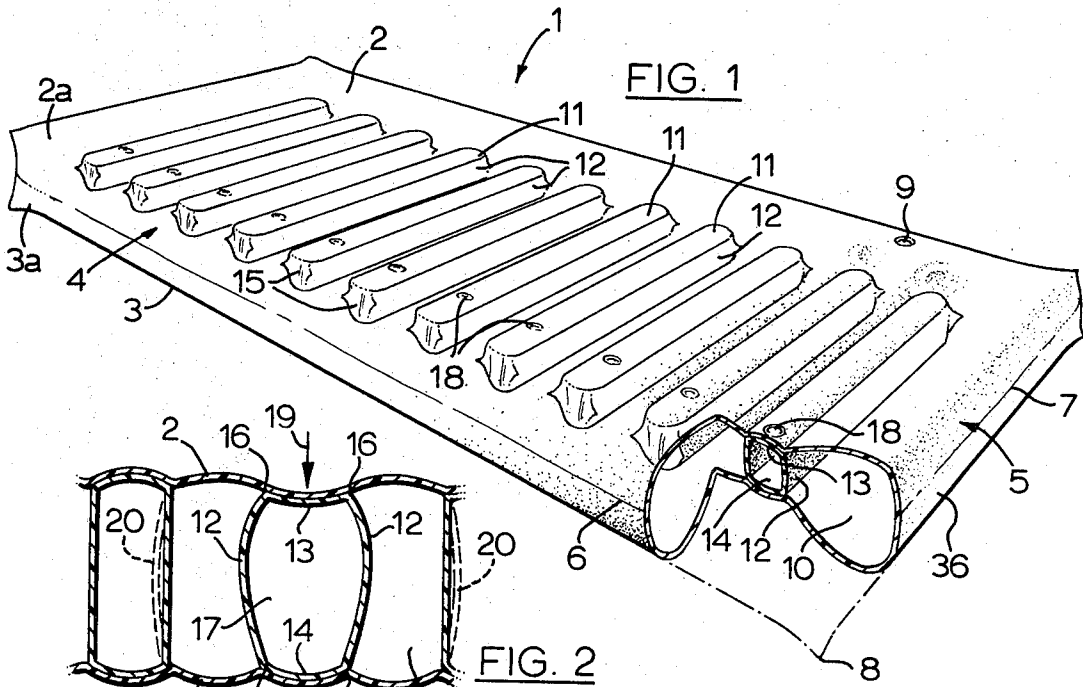

INVENTOR.
WALTER P. NAIL

BY *Douglas S. Johnson*

Attorney

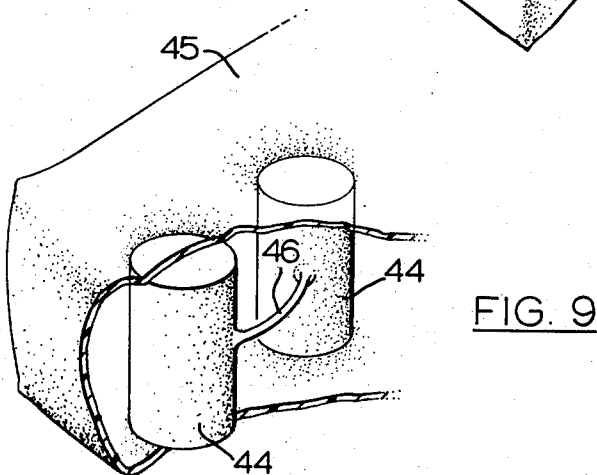
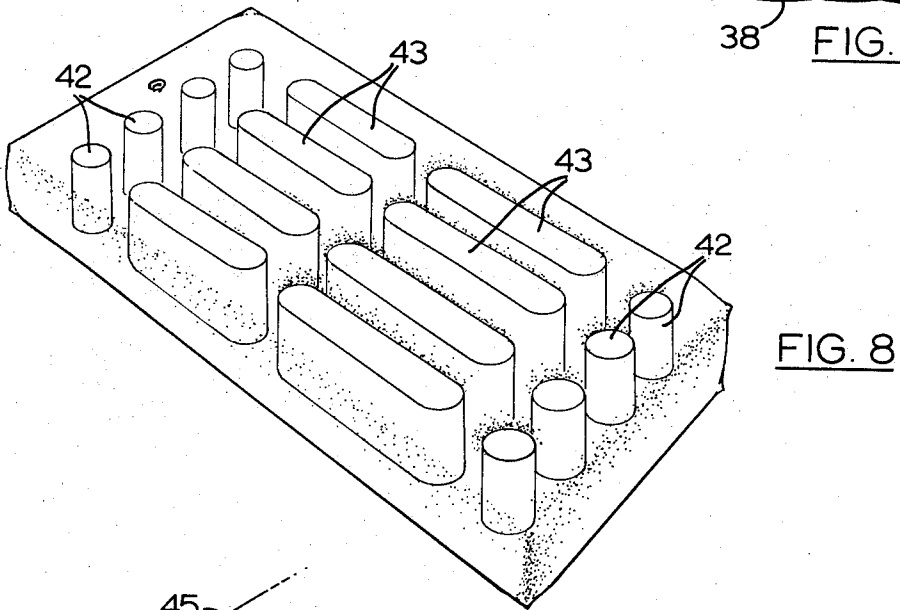
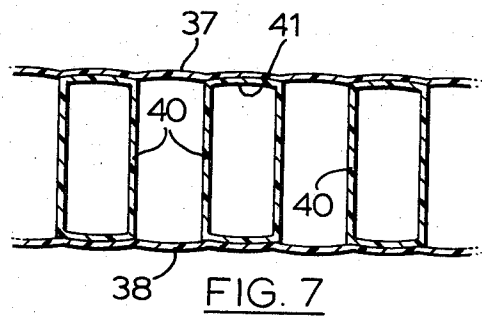
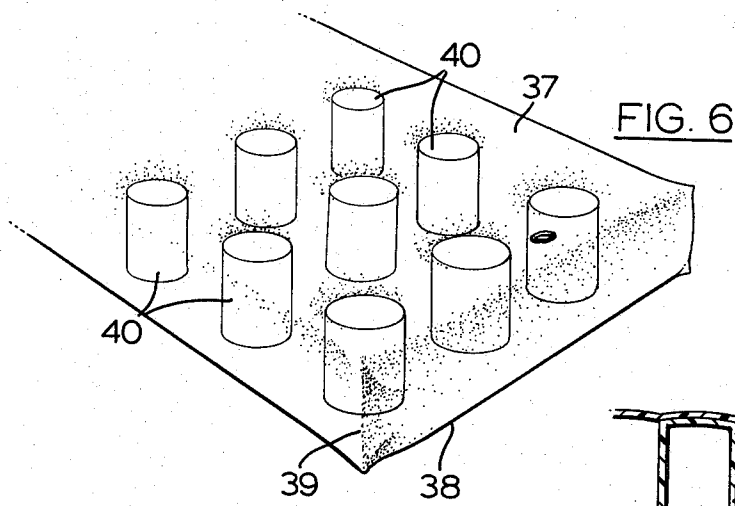

INVENTOR.
WALTER P. NAIL

BY *Douglas S. Johnson*

Attorney

INFLATABLE LOAD SUPPORTING STRUCTURES**FIELD OF INVENTION**

This invention relates to inflatable structures and particularly to inflatable load supporting structures where the function of the structure is to provide a measure of resiliency or a spring effect.

BACKGROUND OF INVENTION

While I have disclosed in my U.S. Pat. Nos. 2,987,735 and 3,029,109 METHODS OF CONTROLLING INFLATABLE ARTICLES to provide a stable inflatable article of any desired shape or configuration, I have now further discovered that I can provide such inflatable articles with a controlled stability or resiliency or springiness by the incorporation into the structure of an "air spring" effect. I have therefore now found that I can provide inflatable structures where substantially any desired stability, stiffness or springiness can be imparted thereto and can be readily altered in use to suit the requirement of the use or the convenience of the user.

SUMMARY OF INVENTION

According to the invention an inflatable structure is provided by utilizing an arrangement of "air beams" within an outer inflatable chamber, the air beams internally enclosing isolating or at least partially restricting pockets of air, the beams serving, on the one hand, to control the shape of the inflatable structure by fixing the separation of opposing walls of the chamber and on the other hand, to set up a resilient resistance to the approach of opposing walls proportional to the internal air pocket pressures and/or degree of isolation or restriction of the air in said internal air pockets, and proportional to the air pressure in the outer inflatable chamber.

For sake of simplicity the invention will be described with reference to a simple structure in the form of a mattress but it will be understood that such illustration is by way of example only and the invention is not limited to any specific structural form.

BRIEF DESCRIPTION OF DRAWING

The invention will be more fully understood with reference to the accompanying drawings in which,

FIG. 1 is a perspective view partly broken away of a mattress constructed to embody the invention and incorporating one form of air beams.

FIG. 2 is an enlarged partial vertical cross sectional view taken at right angles to the direction of the air beams.

FIG. 3 is a fragmentary perspective view of a mattress similar to FIG. 1 but illustrating a modified form of air beam embodying the invention.

FIGS. 4 and 5 are views similar to FIG. 3 but illustrating still further forms of air beams according to the invention.

FIG. 6 is a perspective view partly broken away of an inflatable planar structure embodying the invention in which the air beams or pockets within the outer chamber are constituted by a series of cylindrical columns extending between the upper and lower faces of the structure.

FIG. 7 is an enlarged vertical cross sectional view of the columns of FIG. 6.

FIG. 8 is a perspective view showing another form of inflatable planar structure having various shapes of air beams or pockets within the outer chamber.

FIG. 9 is a broken away perspective view showing another form of inflatable structure embodying the invention in which air pockets are interconnected.

DETAILED DESCRIPTION OF INVENTION

Referring to FIG. 1 there is shown a mattress generally designated at 1 which comprises an outer chamber defined by a top wall 2, a bottom wall 3, side walls 4 and end walls 5. The side and end walls are formed by flaps of the top and bottom walls, the top wall being formed with flaps 2a and the bottom wall with flaps 3a which are sealed together as at 6 to form the side walls 4. Similarly the top wall is provided with flaps 2b and the bottom wall with flaps 3b which are sealed together as at 7 forming the end walls 5. The side and end walls are united by seals 8 to form an inflatable chamber of generally rectilinear form when deflated and of the same general form when inflated by virtue of the beam arrangement as hereinafter more fully described. A suitable valve 9 is provided for inflating what may be termed the outer mattress chamber 10. Arranged internally of the chamber 10 are a series of beams generally designated at 11. Each of the beams are shown as comprising a tube having side walls 12, a top wall 13, a bottom wall 14, and end walls 15. Both the walls of the outer mattress chamber 10 and the beams 11 are formed of a flexible substantially non-extensible material such as a relatively heavy vinyl or similar plastic such as plastic laminates, rubber coated rubber and the like. It will be understood that the thickness of the material will depend upon the maximum pressure to be developed within the mattress and of course the material should not be too thin in any event so that it will not readily puncture. The side walls 12 of beams 11 are sealed at the top and bottom as at 16 to the top wall 2 and bottom wall 3 of the outer chamber 10. The top and bottom walls 13 and 14 of the beams 11 may also if desired be sealed to the top and bottom walls of the chamber 10 respectively, but this is not essential. Alternately only a portion or portions of the top and bottom walls 13 and 14 of the beams may be sealed to the top and bottom walls of the chamber 10. Thus each of the beams 11 constitutes a separate inflatable air chamber 17 completely isolated from the outer chamber 10. Suitable valves 18 are provided for inflating the internal beam chambers 17. In use the mattress is erected by inflating the outer chamber 10 through the valve 9. Then each of the beam chambers 17 is inflated through the respective valve 18 and the stiffness or softness of the mattress and its degree of springiness or any part thereof may be adjusted by changing the pressure in the beams or individual beam and the pressure in the outer chamber 10.

The spring effect produced by the inflated outer chamber 10 and the beams 11 will be better understood with reference to FIG. 2. As illustrated in FIG. 2 when pressure is applied, for example at the point of the arrow 19, the top wall 2 of the outer chamber will tend to displace downwardly toward the bottom wall 3 which will apply pressure simultaneously to the air contained in the beam 11 immediately beneath the arrow and to the outer chamber generally. The air in the beam 11 will tend to compress resisting the downward

pressure and in compressing will tend to force or bulge out the side walls 12. At the same time, the air in the chamber 10 will compress increasing the internal pressure within the chamber 10 and this compressed air will in turn act under the increased pressure to resist the bulging of the beam walls 12 thus increasing the compression of the air in the respective beam chamber 17 to increase the resistance offered to deformation of the mattress in the area of the selected beam under the applied load. If the applied load is heavy enough, the wall of adjoining beams 11 as indicated by the dotted lines 20 will tend to curve inwardly thereby compressing the air in the adjoining beams and increasing the pressure therein which will have a reactive effect, tending to restore the side walls 20 to their original position. This reactive effect will in turn tend to increase the pressure in the chamber 10 to reflect an increased pressure on the walls 12 of the partially collapsed beam to urge the walls thereof towards their original position to act to increase the internal beam pressure and restore it towards its original position.

By controlling the air pressure in the outer chamber 10, and in the beam chambers 17, a resilient spring action having the desired resistance to compression of the mattress can be achieved. Thus the mattress may be made soft so that a weight supported on the mattress will tend to sink into the mattress or it can be made relatively hard so that the mattress will be firm and support a weight with relatively little deformation.

It will be appreciated that one section of the mattress may be made softer or stiffer if desired by inflating the beams to a lesser or greater pressure through the valves 18. In use, of course, the resiliency of the mattress or areas of the mattress can be changed as desired through the control of the inflation.

Since the mattress is made up of a plastic material, which is moisture, as well as air impervious, it will be soil proof, stain proof and can be readily washed without damage.

It will be understood that the mattress may be covered with a suitable pad of foam rubber or the like and any suitable covering or appropriate design.

While FIGS. 1 and 2 illustrate the preferred form of the invention, FIG. 3 illustrates another satisfactory beam structure 21 which may be employed in place of the beams 11. The beam 21 is similar to the beam 11 except that the beam is open ended so that the air can pass from the outer chamber into the beam through an opening at each end indicated at 22, only one end being shown. The same general spring action is achieved except that now there is an exchange of air permitted between the outer chamber 10 and the open chamber 17' internally of the beam. However there is still a measure of restriction in air flow within the chamber 10 and also even in air exchange between the chamber 10 and the internal beam chamber 17' because as the beam 21 tends to collapse under a load by the combined compression of air in chamber 17' and exhaust air from chamber 17' into the outer chamber 10 the compression of the air in the outer chamber 10 will be increased increasing its pressure. Due to this increasing air pressure in chamber 10 there will be an increasing resistance to the movement of the air from internally of the beam into the outer chamber 10 to increase the resistance to collapse of the beam 21 under load. This air

pressure interplay between the air compressed internally and externally of the beam provides a measure of "air spring" effect.

It will be understood that along with and forming an element of this air spring effect the beams 21 limit the bulging of any other portion of the mattress by tying the opposing walls 2 and 3 together to a defined separation and maintaining them essentially planar.

The beams shown in FIGS. 1, 2, and 3 are in effect tubes having upper and lower walls butting the upper and lower mattress walls 2 and 3 respectively to give added support and control to the mattress surfaces 2 and 3. However, the beams need not be complete tubes. In FIG. 4 for instance a satisfactory beam 23 is illustrated which has rounded closed end walls 24 (only one being shown) but the beam is open at the top and bottom. The top edge 25 is sealed throughout its continuous perimeter to the top wall 2 of the mattress and its bottom edge 26 is similarly sealed to the bottom mattress wall 3. A suitable valve 27 allows the isolated chamber 28 defined internally of the beam to be inflated as desired. The effect of the beam 23 is similar to that described in conjunction with FIG. 1. In this connection it will be noted that the two longitudinal side walls of the beam 23 are joined by the end walls 24 and this connection between the side walls or in other words the provision of a seal between the beam and the upper and lower walls 2 and 3 running transversely of the beam provides a stabilizing effect which will resist roll of the walls 2 and 3 of the inflatable structures of FIG. 4. This is the same effect as is achieved by the joining of the side walls 12 of the beams 11 by the top and bottom walls 13 and 14 in the mattress structure shown in FIGS. 1 and 2.

FIG. 5 shows a beam generally designated at 29 which functions in the same manner as the beam 21 of FIG. 3. However beam 29 is simply formed of two side walls 30 sealed at their top and bottom edges 31 and 32 respectively to the top and bottom mattress walls 2 and 3. The end walls 34 (only one of each side being shown) are curved down the side wall of the mattress but are not sealed so that restricted air flow is permitted between the interior beam chamber 35 and the interior chamber 10 of the mattress.

With reference to FIGS. 6 and 7 the inflatable structure comprises a top wall 37, bottom wall 38 and side walls 39. In this case the "beams" 40 are in the form of a cylinder running between the top and bottom walls 37 and 38 and having end walls 41 sealed or glued if desired to the walls 37 and 38. Alternately only an edge perimeter portion or even a limited central portion of the end walls 41 need to be sealed or glued to the walls 37 and 38.

Again the interaction between the various independent air storing pockets or beams within the outer inflatable chamber is of the nature of that described with reference to FIG. 1.

The pockets or beams 40 may be inflated in any desired way for example before being partitioned within the outer chamber or they may be inflated through suitable valves (not shown) or by means of a needle pierced through into the pockets and subsequently withdrawn and the opening sealed.

While again the structure is to be formed from a flexible substantially non extensible material it will be ap-

5

6

preciated that the material will have some give to it depending upon, for example, its thickness and material having some limited stretch within recovery limits may be tolerated or in fact useful to add to or modify the spring effect.

FIG. 8 illustrates an inflatable structure having a combination of cylindrical columns, pockets or beams 42 and elongated beams 43.

As illustrated in FIG. 9 the air pockets, columns or beams 44 instead of being completely independent within the structure 45 may be in communication with each other through conduit 45.

While several very simple forms of the invention have been described, it will be understood that the invention has wide application and various modifications of structure may be made by those skilled in the art without departing from the spirit of the invention or scope of the appended claims.

I claim:

1. An inflatable structure comprising an inflatable outer air chamber formed of flexible substantially non expansible air impervious material and having when deflated a peripheral outline corresponding to the desired structure, and a plurality of inflatable beams arranged in spaced relation within said outer chamber, each of said beams defining an internal air chamber and comprising spaced side wall portions formed of flexible substantially non expansible air impervious material connected to opposed walls of said outer air

chamber to limit separation of said opposed walls, said outer air chamber being in continuous communication between opposite sides of said beams whereby said spaced side wall portions are exposed to the same outer chamber pressure when said outer chamber is inflated, each of said beams being constructed and arranged to preclude transfer of air between said internal air chamber and said outer air chamber in at least certain directions.

2. An inflatable structure as claimed in claim 1 in which at least some of said beams have top and bottom wall portions connected to the opposed walls of said outer chamber.

3. An inflatable structure as claimed in claim 1 in which at least some of said beams comprise tubes said tubes having top and bottom wall portions connected to the opposed walls of said outer chamber.

4. An inflatable structure as claimed in claim 1 in which at least some of said tubes are longitudinal tubes extending longitudinally of the structure.

5. An inflatable structure as claimed in claim 1 in which at least some of said tubes comprise columns extending between the opposed walls of said outer structure.

6. An inflatable structure as claimed in claim 1 in which at least some of said beams comprise longitudinal tubes extending substantially parallel to said one side of said rectilinear structure.

* * * * *

30

35

40

45

50

55

60

65