

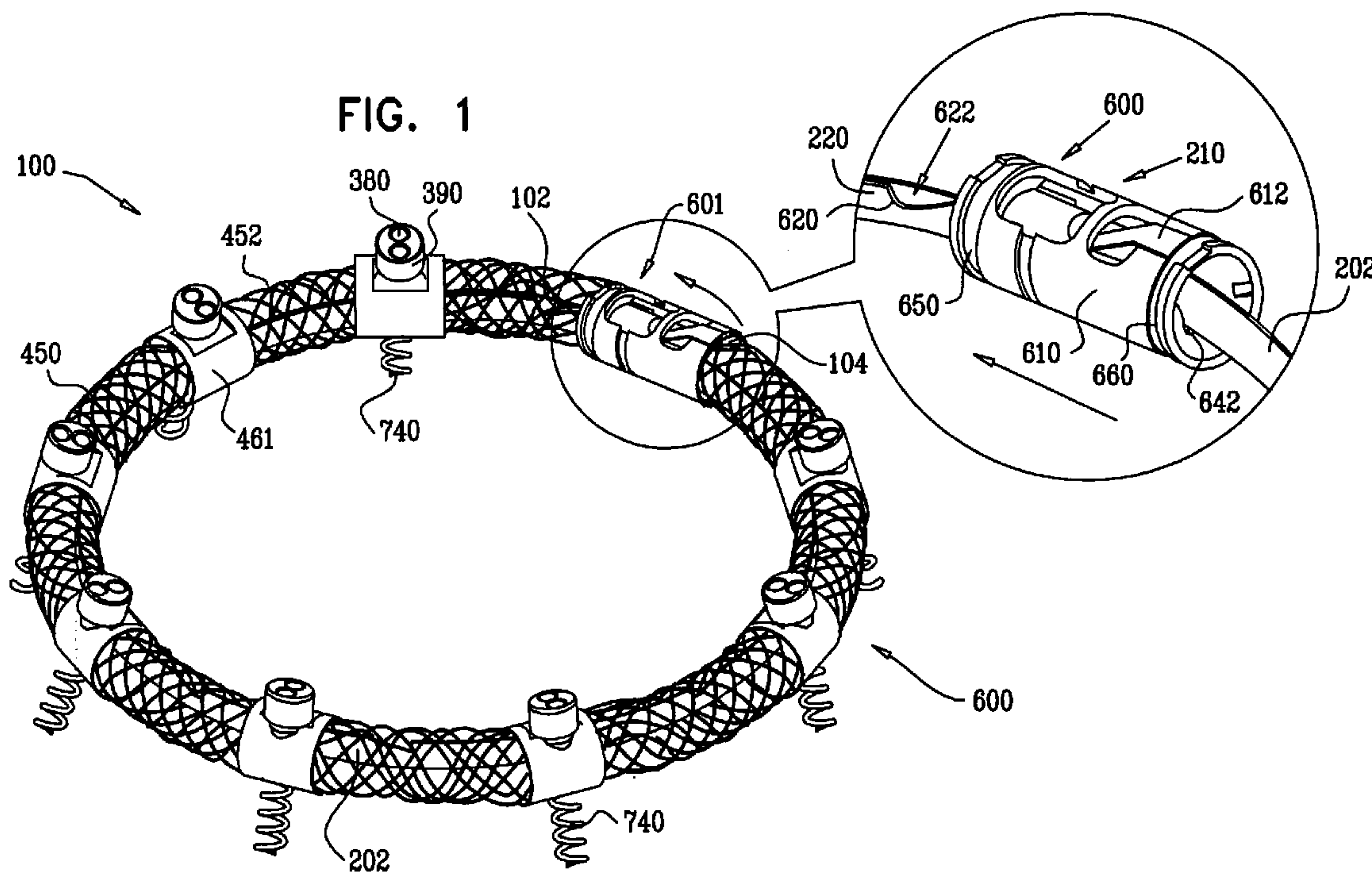

(86) Date de dépôt PCT/PCT Filing Date: 2009/06/15
 (87) Date publication PCT/PCT Publication Date: 2010/01/14
 (85) Entrée phase nationale/National Entry: 2010/12/14
 (86) N° demande PCT/PCT Application No.: IL 2009/000593
 (87) N° publication PCT/PCT Publication No.: 2010/004546
 (30) Priorité/Priority: 2008/06/16 (US61/132,295)

(51) Cl.Int./Int.Cl. *A61M 25/00* (2006.01)
 (71) Demandeur/Applicant:
 VALTECH CARDIO, LTD., IL
 (72) Inventeurs/Inventors:
 GROSS, AMIR, IL;
 BEINART, IFTAH, IL;
 MILLER, ERAN, IL;
 CABIRI, OZ, IL;
 ELIACHAR, ELIAHU, IL;
 LILACH, NIR, IL;
 GROSSFELD, RAM, IL;
 ...
 (74) Agent: GOWLING LAFLEUR HENDERSON LLP

(54) Titre : DISPOSITIFS D'ANNULOPLASTIE ET PROCEDES DE MISE EN PLACE DE CEUX-CI
 (54) Title: ANNULOPLASTY DEVICES AND METHODS OF DELIVERY THEREFOR



(57) **Abrégé/Abstract:**

Apparatus is provided, including a tube (421) shaped to define a tube lumen at least one implant (100) reversibly coupled to the tube (421), and configured for implantation within a body of a patient. The apparatus also comprises two or more longitudinal guide members (470) disposed at least in part along a distal portion of the tube (421), the longitudinal guide members (470) having distal portions thereof configured to be reversibly coupled to the implant (100), and arranged such that application of a force to a first one of the longitudinal guide members (470) steers the distal portion of the tube (421) toward a first location along the implant (100), and application of a force to a second one of the longitudinal guide members (470) steers the distal portion of the tube (421) toward a second location along the implant (100). Other embodiments are also described.

(72) Inventeurs(suite)/Inventors(continued): GOLOM, DMITRY, IL; MEYER-BRODNITZ, GIDEON, IL; MOSAIUF, ARNON, IL

(12) INTERNATIONAL APPLICATION PUBLISHED UNDER THE PATENT COOPERATION TREATY (PCT)

(19) World Intellectual Property Organization
International Bureau(43) International Publication Date
14 January 2010 (14.01.2010)(10) International Publication Number
WO 2010/004546 A1(51) International Patent Classification:
A61M 25/00 (2006.01)Haifa (IL). MOSAIUF, Arnon [IL/IL]; P.O. Box 153,
Geva Carmel 75 (IL).(21) International Application Number:
PCT/IL2009/000593(74) Agents: SANFORD T. COLB & CO. et al.; P.O. Box
2273, 76122 Rehovot (IL).(22) International Filing Date:
15 June 2009 (15.06.2009)(81) Designated States (unless otherwise indicated, for every
kind of national protection available): AE, AG, AL, AM,
AO, AT, AU, AZ, BA, BB, BG, BH, BR, BW, BY, BZ,
CA, CH, CL, CN, CO, CR, CU, CZ, DE, DK, DM, DO,
DZ, EC, EE, EG, ES, FI, GB, GD, GE, GH, GM, GT,
HN, HR, HU, ID, IL, IN, IS, JP, KE, KG, KM, KN, KP,
KR, KZ, LA, LC, LK, LR, LS, LT, LU, LY, MA, MD,
ME, MG, MK, MN, MW, MX, MY, MZ, NA, NG, NI,
NO, NZ, OM, PE, PG, PH, PL, PT, RO, RS, RU, SC, SD,
SE, SG, SK, SL, SM, ST, SV, SY, TJ, TM, TN, TR, TT,
TZ, UA, UG, US, UZ, VC, VN, ZA, ZM, ZW.

(25) Filing Language: English

(26) Publication Language: English

(30) Priority Data:
61/132,295 16 June 2008 (16.06.2008) US(71) Applicant (for all designated States except US): VAL-
TECH CARDIO, LTD. [IL/IL]; 6 Yoni Netanyahu
Street, 60376 Or-Yehuda (IL).

(72) Inventors; and

(75) Inventors/Applicants (for US only): GROSS, Amir
[IL/IL]; 87 HaYarkon Street, 63432 Tel Aviv (IL).
BEINART, Iftah [IL/IL]; 8 Yitzhak Ben Tzvi Street,
45373 Hod Hasharon (IL). MILLER, Eran [IL/IL]; 546
Hateena Street, 76803 Moshav Beit Elazari (IL).
CABIRI, Oz [IL/IL]; 775 Nachal Natof Street, 71799
Macabim Reut (IL). ELIACHAR, Eliahu [IL/IL]; 25
Yefe Nof Street, 34371 Haifa (IL). LILACH, Nir [IL/IL];
30063 Kfar Yehoshua (IL). GROSSFELD, Ram [IL/IL];
4a Eitanim Street, 34384 Haifa (IL). GOLOM, Dmitry
[IL/IL]; 15/3 Yair Stern Street, 35475 Haifa (IL). MEY-
ER-BRODNITZ, Gideon [IL/IL]; 2 Hillel Street, 33073(84) Designated States (unless otherwise indicated, for every
kind of regional protection available): ARIPO (BW, GH,
GM, KE, LS, MW, MZ, NA, SD, SL, SZ, TZ, UG, ZM,
ZW), Eurasian (AM, AZ, BY, KG, KZ, MD, RU, TJ,
TM), European (AT, BE, BG, CH, CY, CZ, DE, DK, EE,
ES, FI, FR, GB, GR, HR, HU, IE, IS, IT, LT, LU, LV,
MC, MK, MT, NL, NO, PL, PT, RO, SE, SI, SK, TR),
OAPI (BF, BJ, CF, CG, CI, CM, GA, GN, GQ, GW, ML,
MR, NE, SN, TD, TG).

Published:

— with international search report (Art. 21(3))

(54) Title: ANNULOPLASTY DEVICES AND METHODS OF DELIVERY THEREFOR

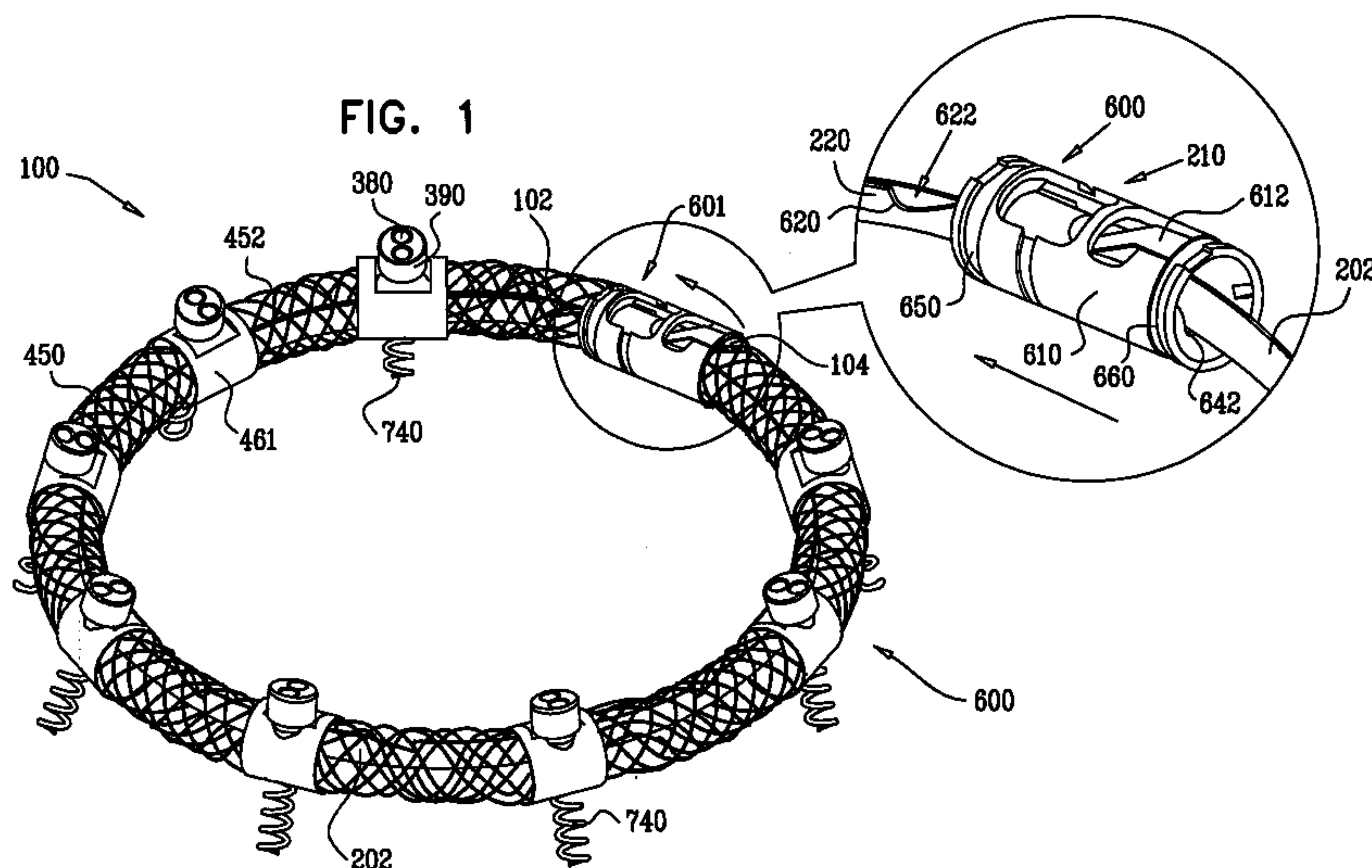

(57) Abstract: Apparatus is provided, including a tube (421) shaped to define a tube lumen at least one implant (100) reversibly coupled to the tube (421), and configured for implantation within a body of a patient. The apparatus also comprises two or more longitudinal guide members (470) disposed at least in part along a distal portion of the tube (421), the longitudinal guide members (470) having distal portions thereof configured to be reversibly coupled to the implant (100), and arranged such that application of a force to a first one of the longitudinal guide members (470) steers the distal portion of the tube (421) toward a first location along the implant (100), and application of a force to a second one of the longitudinal guide members (470) steers the distal portion of the tube (421) toward a second location along the implant (100). Other embodiments are also described.



WO 2010/004546 A1

ANNULOPLASTY DEVICES AND METHODS OF DELIVERY THEREFOR

CROSS-REFERENCES TO RELATED APPLICATIONS

The present application claims priority from US Provisional Patent Application 61/132,295 to Gross et al., entitled, "Annuloplasty devices and methods of delivery therefor," filed June 16, 2008, which is incorporated herein by reference.

FIELD OF THE INVENTION

The present invention relates in general to valve repair. More specifically, the present invention relates to percutaneous repair of a mitral valve of a patient.

BACKGROUND OF THE INVENTION

Ischemic heart disease causes mitral regurgitation by the combination of ischemic dysfunction of the papillary muscles, and the dilatation of the left ventricle that is present in ischemic heart disease, with the subsequent displacement of the papillary muscles and the dilatation of the mitral valve annulus.

Dilation of the annulus of the mitral valve prevents the valve leaflets from fully coapting when the valve is closed. Mitral regurgitation of blood from the left ventricle into the left atrium results in increased total stroke volume and decreased cardiac output, and ultimate weakening of the left ventricle secondary to a volume overload and a pressure overload of the left atrium.

US 2007/0299424 to Cumming et al. describes a catheter assembly includes an inner liner made of flexible material and an outer layer having a steering mechanism. The steering mechanism includes at least one flat wire and a corresponding lumen through which the flat wire may travel. The steering mechanism may also include at least one pull ring to which the flat wires are attached. A layer of heat shrink material may encompass the outer layer. A braided wire assembly, which may have a braid density that varies along the length of the catheter, may also be provided in the outer layer. The overall cross-section of the catheter assembly is preferably substantially circular. A catheter shaft may include a plurality of segments of differing hardness characteristics. The outer layer typically comprises a melt processing polymer such that the catheter assembly may be laminated using heat.

PCT Publication WO 96/40344 to Stevens-Wright et al. describes a bidirectional steering catheter comprising a distal electrode assembly, a flexible tip assembly, an elongated shaft having a central lumen running the length of the shaft, and a handle/actuator. A plurality of ring electrodes are attached to the surface of the flexible tip assembly. Signal wires running the length of the catheter are electrically connected to each ring electrode. At least two pull cables having first and second ends extend distally through the central lumen. The first end of each pull cable is attached to the handle/actuator. The second end of each pull cable is attached to the distal electrode assembly, such that the distal electrode assembly may be moved between a first and second position within a single plane by manipulating the handle/actuator. At least two reinforcement members are located inside the flexible tip assembly. Each reinforcement member has a proximal section, a middle section and a distal section. Each proximal section has a larger diameter than each middle section, thus being stiffer than the middle section. This variable stiffness along the length of each reinforcement member distributes stresses evenly along the length of the tip assembly.

US 2005/0004668 to Aklog et al. describes implantable devices and methods for the repair of a defective cardiac valve. The implantable devices include an annuloplasty ring and a restraining and/or a remodeling structure or mechanism. The annuloplasty ring functions to reestablish the normal size and shape of the annulus bringing the leaflets in proximity to each other. A device having a remodeling structure further facilitates remodeling of the valve but allows the use of a flexible ring. The restraining structure functions to restrain the abnormal motion of at least a portion of the valve being repaired. The restraining and remodeling structures may include at least one strut across the interior of the circumference of the ring.

US 2005/0171601 to Cosgrove describes an annuloplasty repair segment and template for heart valve annulus repair. The elongate flexible template may form a distal part of a holder that also has a proximal handle. Alternatively, the template may be releasably attached to a mandrel that slides within a delivery sheath, the template being released from the end of the sheath to enable manipulation by a surgeon. A tether connecting the template and mandrel may also be provided. The template may be elastic, temperature responsive, or multiple linked segments. The template may be aligned with the handle and form a two- or three-dimensional curve out of alignment with the handle such that the annuloplasty repair segment attached thereto conforms to the curve. The

template may be actively or passively converted between its straight and curved positions. The combined holder and ring are suited for minimally-invasive surgeries in which the combination is delivered to an implantation site through a small access incision with or without a cannula, or through a catheter passed through the patient's vasculature.

5 US Patent 6,102,945 to Campbell describes a support ring for a natural human heart valve, including a first ring portion having opposite terminal ends and a second ring portion having opposite terminal ends. An interconnector extends through and interconnects the first and second ring portions, to maintain the opposite terminal ends of the first ring portion adjacent the opposite terminal ends of the second ring portion, to
10 form a segmented ring having a first and a second interface between the first and second ring portions. The first ring portion is of a greater length than the second ring portion. The ring portions are separable by severing the interconnector at the first and second interfaces, thus producing two variable size ring segments.

US Patent 5,593,424 to Northrup III describes an apparatus and method for
15 reducing the circumference of a vascular structure comprising the steps of providing a plurality of sutures and a plurality of discrete suture support segments of a biocompatible, inert material. Each suture support segment has at least two suture holes spaced a predetermined distance apart. The method includes individually suturing each discrete suture support segment to the vascular structure with one of the plurality of sutures by
20 effecting a horizontal mattress (U-shaped) suture along the vascular structure through a length of tissue of the vascular structure such that the length (D') of tissue sutured is greater than distance (D); and tightening and tying off the suture, whereby each sutured suture support segment creates an imbrication in the vascular structure, thereby reducing the circumference thereof. A biocompatible, inert stabilizing material is described as
25 being optionally affixed over the suture support segments and the vascular structure prior to tying off the suture to stabilize the interval between the suture support segments and eliminate direct exposure of the segmented apparatus to blood.

The following patents and patent applications may be of interest:

EP Patent EP 06/14342 to Pavcnik et al.

30 EP Patent EP 10/06905 to Organ

PCT Publication WO 00/22981 to Cookston et al.

PCT Publication WO 01/26586 to Seguin

- PCT Publication WO 01/56457 to Pruitt
- PCT Publication WO 03/047467 to Cosgrove et al.
- PCT Publication WO 04/103434 to Martin et al.
- PCT Publication WO 05/046488 to Douk et al.
- 5 PCT Publication WO 06/012013 to Rhee et al.
- PCT Publication WO 06/012038 to Shaoulian et al.
- PCT Publication WO 06/086434 to Powell et al.
- PCT Publication WO 06/097931 to Gross et al.
- PCT Publication WO 06/105084 to Cartledge et al.
- 10 PCT Publication WO 07/011799 to Navia et al.
- PCT Publication WO 07/121314 to Rafiee et al.
- PCT Publication WO 07/136981 to Cumming et al.
- PCT Publication WO 96/39963 to Abela et al.
- PCT Publication WO 97/01369 to Taylor et al.
- 15 PCT Publication WO 98/46149 to Organ
- US Patent 3,656,185 to Carpentier
- US Patent 4,961,738 to Mackin
- US Patent 5,306,296 to Wright et al.
- US Patent 5,325,845 to Adair
- 20 US Patent 5,716,370 to Williamson, IV et al.
- US Patent 5,855,614 to Stevens et al.
- US Patent 6,074,401 to Gardiner et al.
- US Patent 6,524,338 to Gundry
- US Patent 6,533,772 to Sherts et al.
- 25 US Patent 6,569,198 to Wilson et al.
- US Patent 6,619,291 to Hlavka et al.

US Patent 6,626,899 to Houser et al.

US Patent 6,629,534, PCT Publication WO 06/116558 and US 2004/0039442 to St. Goar et al.

US Patent 6,752,813 to Golfarb et al.

5 US Patent 6,764,510 to Vidlund et al.

US Patent 6,893,459 to Macoviak

US Patent 6,918,917 to Nguyen et al.

US Patent 6,926,730 to Nguyen et al.

US Patent 6,986,775 to Morales et al.

10 US Patent 7,004,176 to Lau

US Patent 7,101,395 to Tremulis et al.

US Patent 7,150,737 to Purdy et al.

US Patent 7,172,625 to Shu et al.

US Patent 7,175,660 to Cartledge et al.

15 US Patent 7,220,277 to Arru et al.

US Patent 7,226,467 to Lucatero et al.

US 2001/0021874 to Capentier

US 2002/0198586 to Inoue

US 2003/0050693 to Quijano et al.

20 US 2003/0078465 to Pai et al.

US 2003/0114901 to Loeb et al.

US 2003/0191528 and US Patent 6,805,711 to Quijano et al.

US 2003/0199974 to Lee et al.

US 2004/0127983 to Mortier et al.

25 US 2004/0138744 to Lashinski et al.

US 2004/0148021 to Cartledge et al.

- US 2004/0193191 to Starksen et al.
- US 2004/0236419 to Milo
- US 2004/0243227 to Starksen et al.
- US 2004/0260394 to Douk et al.
- 5 US 2005/0055038 to Kelleher et al.
- US 2005/0096740 to Langberg et al.
- US 2005/0222678 to Lashinski et al.
- US 2005/0288778 to Shaoulian et al.
- US 2005/0288781 to Moaddeb et al.
- 10 US 2006/0095009 to Lampropoulos et al.
- US 2006/0195134 to Crittenden
- US 2006/0282161 to Huynh et al.
- US 2006/0247763 to Slater
- US 2007/0080188 to Spence et al.
- 15 US 2007/0244556 to Rafiee et al.
- US 2007/0299424 to Cumming et al.
- US 2008/0027483 to Cartledge et al.
- US 2004/0148019 and US 2004/0148020 to Vidlund et al.
- US 2004/0260393 to Rahdert et al. and US 2004/0127982 to Machold et al.
- 20 US 2005/0010287 and 2004/0138745 to Macoviak et al.

The following articles may be of interest:

O'Reilly S et al., "Heart valve surgery pushes the envelope," Medtech Insight 8(3): 73, 99-108 (2006)

25 Dieter RS, "Percutaneous valve repair: Update on mitral regurgitation and endovascular approaches to the mitral valve," Applications in Imaging, Cardiac Interventions, Supported by an educational grant from Amersham Health pp. 11-14 (2003)

Swain CP et al., "An endoscopically deliverable tissue-transfixing device for securing biosensors in the gastrointestinal tract," *Gastrointestinal Endoscopy* 40(6): 730-734 (1994)

5 Odell JA et al., "Early Results of a Simplified Method of Mitral Valve Annuloplasty," *Circulation* 92:150-154 (1995)

SUMMARY OF THE INVENTION

In some embodiments of the present invention, systems and surgical methods are provided for repair of a dilated mitral valve of a patient. Typically, an annuloplasty structure, e.g., at least one elongate segment of an annuloplasty ring, is transcatheterally advanced toward an atrial surface of an annulus of the mitral valve, using a percutaneous transcatheter approach. In some embodiments, the annuloplasty structure is positioned at the annulus using a minimally-invasive approach, e.g., intercostal access. In some embodiments of the present invention, systems and methods are provided for repairing the valve of the patient using an open-heart procedure. For embodiments in which the annuloplasty structure is transcatheterally advanced toward the annulus, the annuloplasty structure assumes (1) a linear configuration having first and second ends as it is advanced transcatheterally toward the left atrium of the patient, and (2) a closed configuration, e.g., a substantially ring-shaped or "D"-shaped configuration, once deployed within the left atrium of the patient.

In some embodiments, the annuloplasty structure has a longitudinal axis when disposed in a linear state thereof and comprises one or more, e.g., a plurality, of subunits that are compressible along the longitudinal axis of the annuloplasty structure. Typically, the annuloplasty structure comprises one or more, e.g., a plurality, of anchor mounts which are each configured to facilitate anchoring of the annuloplasty structure to the annulus of the patient.

Typically, the annuloplasty structure is shaped to define a substantially tubular structure which defines at least one hollow lumen configured for passage therethrough of a ratchet mechanism and/or at least one contracting element, e.g., wire or cable. In some embodiments, the annuloplasty structure is shaped to define a first lumen for passage therethrough of the ratchet mechanism and a second lumen for passage therethrough of the at least one contracting wire.

Typically, the ratchet of the ratchet mechanism is shaped to define an elongate structure shaped to define a plurality of engaging structures, e.g., holes, slots, grooves, etc., therealong. The engaging structures maintain various locked configurations of the annuloplasty structure. As the annuloplasty structure is advanced toward a heart of the patient, the annuloplasty structure is shaped to define a substantially linear configuration having first and second ends. Once the annuloplasty structure has been positioned within

the atrium of the patient, the contracting wire is pulled, thereby drawing together the respective ends of the ratchet such that the annuloplasty structure, in turn, assumes a generally circular configuration. Ultimately, the ratchet mechanism locks in place the respective ends of the ratchet, thereby maintaining an adjusted perimeter of the
5 annuloplasty structure.

In some embodiments of the present invention, a delivery system is provided for positioning and anchoring of the annuloplasty structures described herein to the annulus of the patient. The delivery system comprises an advancement catheter housing (a) the annuloplasty structure in a distal portion thereof, and (b) a steerable catheter disposed
10 proximally with respect to the annuloplasty structure. A plurality of guide members are reversibly coupled to the annuloplasty structure and to the steerable catheter. These guide members facilitate steering of the steerable catheter toward specific locations along the annuloplasty structure. Typically, by pulling on the proximal end of a given guide member, the distal end of the catheter is steered toward a given location of annuloplasty
15 structure.

Once the distal end of the catheter is disposed in proper orientation with respect to the given location along the annuloplasty structure, an anchoring device, e.g., an anchor or a suture, is delivered through the steerable catheter and toward the given location. The annuloplasty structure is then anchored to the annulus via the anchoring device. Thus, the
20 steerable catheter and guide members facilitate target-specific anchoring of the annuloplasty structure to the annulus.

In some embodiments, the anchoring device comprises a helical anchor configured to be corkscrewed into the annulus of the patient. In some embodiments, the anchoring device comprises an anchor configured to assume a predetermined shape once it emerges
25 from within the distal end of the catheter.

In some embodiments, the annuloplasty structure is shaped to define a single tubular element having first and second ends which meet and form a ring structure once inside the left atrium and manipulated by the operating physician. In some embodiments, the annuloplasty structure comprises at least two discrete hollow ring segments which are
30 each anchored at respective positions along the annulus circumference of the mitral valve. In either embodiment, the contracting wire functions as a drawstring to pull the segment(s) into proper orientation once the segment(s) has been anchored to the annulus.

Using real-time monitoring, tactile feedback and optionally in combination with fluoroscopic imaging, the contracting wire is then pulled. Consequently, the leaflets are drawn toward one another in accordance with the level of dilation of the preoperative mitral valve. Thus, generally, the normal structural configuration is returned to the leaflets, effecting a reduction in mitral valve perimeter/size and in valve regurgitation.

In some embodiments of the present invention, a delivery tool is provided for use during an open-heart procedure in order to anchor to the annulus the annuloplasty structures described herein. The handle of the tool is coupled to a plurality of hollow-lumen tubes. The respective proximal ends of tubes are accessible from a proximal portion of the handle, and the respective distal portions of the tubes are attached to the annuloplasty structure at respective locations thereof. The annuloplasty structure is advanced by the tool and toward the annulus while assuming its closed configuration. Once positioned along the annulus, a respective anchoring device is advanced through each of the tubes, through the annuloplasty structure, and subsequently into the tissue of the annulus.

Particular embodiments are described herein for implementing these techniques.

There is therefore provided, in accordance with respective embodiments of the present invention, the following inventive concepts:

1. Apparatus, including:
 - a tube shaped to define a tube lumen;
 - at least one implant reversibly coupled to the tube, and configured for implantation within a body of a patient; and
 - two or more longitudinal guide members disposed at least in part along a distal portion of the tube, the longitudinal guide members having distal portions thereof configured to be reversibly coupled to the implant, and arranged such that application of a force to a first one of the longitudinal guide members steers the distal portion of the tube toward a first location along the implant, and application of a force to a second one of the longitudinal guide members steers the distal portion of the tube toward a second location along the implant.
2. The apparatus according to inventive concept 1, wherein the implant includes an annuloplasty structure.

3. The apparatus according to inventive concept 1, wherein the implant includes a braided mesh.
4. The apparatus according to inventive concept 1, wherein the implant includes at least one subunit that is compressible along a longitudinal axis of the implant.
5. The apparatus according to inventive concept 1, wherein the implant is configured for transcatheter advancement into a body cavity of the patient.
6. The apparatus according to inventive concept 1, wherein the implant is configured for transcatheter advancement into an atrium of a heart of the patient.
7. The apparatus according to inventive concept 1, wherein the apparatus further includes a housing configured to surround at least a portion of the tube, the housing being shaped to define one or more channels configured for passage therethrough of the two or more longitudinal guide members, and wherein the housing is configured to move rotationally with respect to a longitudinal axis of the tube.
8. The apparatus according to inventive concept 7, wherein the housing is shaped to define two or more channels, wherein each channel is configured for passage therethrough of a respective one of the two or more longitudinal guide members.
9. The apparatus according to inventive concept 1, wherein the implant includes at least one elongate segment.
10. The apparatus according to inventive concept 9, wherein the elongate segment includes a shape-memory alloy, the alloy being configured to assume a curved configuration once the segment has been advanced into an atrium of a heart of the patient.
11. The apparatus according to inventive concept 9, wherein the elongate segment includes a ratchet mechanism including a body portion, a first end shaped to define at least one first engaging structure, and a second end shaped to define at least one second engaging structure configured to engage the first engaging structure.
12. The apparatus according to inventive concept 11, wherein:
 - the body portion is shaped to define at least one tubular body portion having at least one lumen therein,
 - the apparatus further includes a wire disposed at least in part within the lumen of the body portion, and

the tubular body portion is configured to be advanced toward a left atrium of the patient in a generally straight configuration and subsequently to assume a curved configuration in response to a contracting force applied thereto by contraction of the wire.

13. The apparatus according to inventive concept 11, wherein:

5 the body portion is shaped to define a flat body portion,
the apparatus further includes a wire disposed at least alongside the body portion,
and

10 the elongate segment is configured to be advanced toward a left atrium of the patient in a generally straight configuration and subsequently to assume a curved configuration in response to a contracting force applied thereto by contraction of the wire.

14. The apparatus according to inventive concept 9, wherein:

the elongate segment is shaped to define an elongate tube having a lumen therein,
and

15 the apparatus further includes a ratchet mechanism configured to be disposed within the lumen of the elongate segment, the ratchet mechanism including a body portion, a first end shaped to define at least one first engaging structure, and a second end shaped to define at least one second engaging structure configured to engage the first engaging structure.

15. The apparatus according to inventive concept 14, the apparatus further includes a
20 wire disposed at least in part within the lumen of the elongate segment, wherein the elongate segment is configured to be advanced toward a left atrium of the patient in a generally straight configuration and subsequently to assume a curved configuration in response to a contracting force applied thereto by contraction of the wire.

16. The apparatus according to inventive concept 15, wherein the ratchet mechanism
25 is configured to be advanced toward the left atrium of the patient in a generally straight configuration and subsequently to assume a curved configuration in response to the contracting force.

17. The apparatus according to inventive concept 15, wherein, in response to the
30 contracting force, the wire is configured to draw together opposing ends of the ratchet mechanism and opposing ends of the elongate segment, and wherein the ratchet mechanism is configured to maintain respective first ratcheted perimeters of the elongate segment and the ratchet mechanism.

18. The apparatus according to inventive concept 17, wherein, in response to an additional contracting force by additional contraction of the wire, the wire is configured to contract the ratchet mechanism and the elongate segment to respective second ratcheted perimeters thereof, each second ratcheted perimeter being smaller than the respective first ratcheted perimeters, and wherein the ratchet mechanism is configured to maintain the respective second ratcheted perimeters of the ratchet mechanism and the elongate segment.

19. The apparatus according to inventive concept 9, wherein the elongate segment includes first and second segments configured for simultaneous advancement toward an atrium of a heart of the patient.

20. The apparatus according to inventive concept 19, wherein the first and second segments are configured to be advanced toward the atrium of the patient in a generally straight configuration and subsequently to assume a curved configuration.

21. The apparatus according to inventive concept 19, wherein the first and second segments include a shape-memory alloy, the alloy being configured to assume a curved configuration once the segments have been advanced into the atrium of the patient.

22. The apparatus according to inventive concept 9, wherein the elongate segment includes two or more anchor mounts each having longitudinal axes thereof that are transverse to a longitudinal axis of the elongate segment, each mount shaped to provide a channel aligned along the longitudinal axis of the respective anchor mount that is transverse to the longitudinal axis of the anchor mount.

23. The apparatus according to inventive concept 22, wherein application of the force to the first one of the longitudinal guide members steers the distal portion of the tube toward a first one of the two or more anchor mounts, and wherein application of the force to the second one of the longitudinal guide members steers the distal portion of the tube toward a second one of the two or more anchor mounts.

24. The apparatus according to inventive concept 22, wherein the elongate segment includes at least one subunit disposed between the two or more anchor mounts, the subunit being compressible along the longitudinal axis of the elongate segment.

25. The apparatus according to inventive concept 22, wherein a respective one of the two or more longitudinal guide members is reversibly coupled to each of the two or more anchor mounts.

26. The apparatus according to inventive concept 25, wherein a distal end of each of the two or more longitudinal guide members is reversibly coupled to a lateral wall of a respective one of the two or more anchor mounts:

27. The apparatus according to inventive concept 25, wherein:

5 the elongate segment is shaped to define an elongate tube having a lumen thereof, the two or more anchor mounts are each shaped to define at least one lumen having a longitudinal axis thereof aligned in parallel with a longitudinal axis of the lumen of the elongate tube, and

10 the apparatus further includes a ratchet mechanism configured to be disposed within the lumen of the elongate segment and within respective lumens of the two or more anchor mounts, the ratchet mechanism including a body portion, a first end shaped to define at least one first engaging structure, and a second end shaped to define at least one second engaging structure configured to engage the first engaging structure.

15 28. The apparatus according to inventive concept 27, further comprising a wire disposed at least in part within the lumen of the elongate segment and within respective lumens of the two or more anchor mounts, wherein the elongate segment is configured to be advanced toward an atrium of a heart of the patient in a generally straight configuration and subsequently to assume a curved configuration in response to a contracting force applied thereto by contraction of the wire.

20 29. The apparatus according to inventive concept 28, wherein the ratchet mechanism is configured to be advanced toward the atrium of the patient in a generally straight configuration and subsequently to assume a curved configuration in response to the contracting force.

25 30. The apparatus according to inventive concept 28, wherein, in response to the contracting force, the wire is configured to draw together opposing ends of the ratchet mechanism and opposing ends of the elongate segment, and wherein the ratchet mechanism is configured to maintain respective first ratcheted perimeters of the ratchet mechanism and the elongate segment.

30 31. The apparatus according to inventive concept 30, wherein, in response to an additional contracting force by additional contraction of the wire, the wire is configured to contract the ratchet mechanism and the elongate segment to respective second ratcheted perimeters thereof, each second ratcheted perimeters being smaller than the respective

first ratcheted perimeters, and wherein the ratchet mechanism is configured to maintain the respective second ratcheted perimeters of the ratchet mechanism and the elongate segment.

5 32. The apparatus according to inventive concept 25 a bar configured to be disposed within the channel.

33. The apparatus according to inventive concept 32, wherein the bar is disposed within the channel angularly with respect to the longitudinal axis of the channel.

34. The apparatus according to inventive concept 33, wherein the bar is disposed within the channel substantially parallel to the longitudinal axis of the elongate segment.

10 35. The apparatus according to inventive concept 25, further including at least one anchor configured to be advanced through the lumen of the tube, wherein the anchor is configured to be advanced through the channel of a first one of the two or more anchor mounts in response to steering the distal portion of the tube toward the anchor mount by applying the force to the first one of the longitudinal guide members.

15 36. The apparatus according to inventive concept 35, wherein the anchor includes a pointed distal tip.

37. The apparatus according to inventive concept 35, wherein the longitudinal guide member is configured to be decoupled from the anchor mount subsequent to the anchoring of the anchor to an annulus.

20 38. The apparatus according to inventive concept 35, wherein the anchor is configured to assume a first configuration as it is advanced through the channel and to assume a second configuration as it is implanted within tissue of the patient.

25 39. The apparatus according to inventive concept 38, wherein the anchor is configured to assume a straight configuration as it is advanced distally through the channel and to assume a curved configuration as it is implanted within tissue of the patient.

40. The apparatus according to inventive concept 39, wherein the anchor is configured to assume a straight configuration as it is advanced distally through the channel and wherein a portion thereof is configured to curve proximally as it is implanted within tissue of the patient.

41. The apparatus according to inventive concept 35, wherein the anchor includes a helical element at a distal portion thereof, the helical element shaped to define a proximal end of the helical element and a distal end of the helical element.

5 42. The apparatus according to inventive concept 41, further including an advancement structure having a distal tip thereof, wherein at least a portion of the proximal end of the helical element is configured to be coupled to the distal tip of the advancement structure.

10 43. The apparatus according to inventive concept 42, wherein the helical element is shaped to define a first number of proximal rotational subunits and a second number of distal rotational subunits, and wherein the proximal rotational subunits are wrapped around the distal tip of the advancement structure.

44. The apparatus according to inventive concept 43, wherein the proximal rotational subunits are coupled to the distal tip of the advancement structure by a first frictional force.

15 45. The apparatus according to inventive concept 44, wherein the second number is greater than the first number.

46. The apparatus according to inventive concept 45, wherein the advancement structure is configured to be rotated and, in response to the rotation, the distal rotational subunits are configured to be implanted within an annulus of the patient.

20 47. The apparatus according to inventive concept 46, wherein at least a portion of the distal tip is shaped to define a protrusion disposed adjacent to the proximal end of the helical element, the protrusion being configured to apply a circumferentially-directed force to the proximal end of the helical element as the advancement structure is rotated.

25 48. The apparatus according to inventive concept 46, wherein during the rotation of the advancement structure:

the proximal rotational subunits are configured to slide distally along the distal tip of the advancement structure, and

in response to the sliding, a portion of the first number of proximal rotational subunits remains wrapped around the distal tip of the advancement structure.

49. The apparatus according to inventive concept 48, wherein a number of proximal rotational subunits in the portion is less than the first number of proximal rotational subunits.
50. The apparatus according to inventive concept 41, wherein:
5 the helical element is shaped to define at least two adjacent distal rotational subunits and at least two adjacent proximal rotational subunits, and
a distance between the two adjacent distal rotational subunits is greater than a distance between the two adjacent proximal rotational subunits.
51. The apparatus according to inventive concept 50, further including a bar
10 configured to be disposed within the channel.
52. The apparatus according to inventive concept 50, wherein the bar is disposed within the channel angularly with respect to the longitudinal axis of the channel.
53. The apparatus according to inventive concept 52, wherein the bar is disposed within the channel substantially parallel to the longitudinal axis of the elongate segment.
- 15 54. The apparatus according to inventive concept 52, wherein the distance between the distal rotational subunits enables the distal rotational subunits to be corkscrewed around the bar and subsequently into an annulus of the patient.
55. The apparatus according to inventive concept 52, wherein a diameter of the bar is greater than the distance between the two adjacent proximal rotational subunits and less
20 than the distance between the two adjacent distal rotational subunits.
56. The apparatus according to inventive concept 52, wherein the distance between the proximal rotational subunits restricts the proximal rotational subunits from being corkscrewed around the bar and into an annulus of the patient.
57. Apparatus, including:
25 a tube shaped to define a tube lumen;
at least one implant reversibly coupled to the tube and configured for implantation within a body of a patient; and
one or more longitudinal guide members disposed at least in part along a distal portion of the tube, the one or more longitudinal guide members having a distal portions
30 thereof configured to be reversibly coupled to the implant, and arranged such that

application of a force to the one or more longitudinal guide members steers the distal portion of the tube toward a first location along the implant.

58. A method for repairing a valve of a body of a patient, the valve including an annulus and at least first and second leaflets, including:

- 5 advancing a tube shaped to define a tube lumen toward the valve of the patient;
 advancing toward the valve at least one annuloplasty structure reversibly coupled to the tube and at respective locations thereof to two or more longitudinal guide members at respective distal portions thereof, the longitudinal guide members being disposed at least in part along a distal portion of the tube;
- 10 positioning the annuloplasty structure against the annulus of the patient;
 steering the distal portion of the tube toward a first location along the annuloplasty structure by pulling a first one of the two or more longitudinal guide members; and
 steering the distal portion of the tube toward a second location along the annuloplasty structure by pulling a second one of the two or more longitudinal guide members.
- 15

59. The method according to inventive concept 58, wherein advancing the tube and the annuloplasty structure includes transcatheterally advancing the tube and the annuloplasty structure during a single transcatheter advancement thereof.

60. The method according to inventive concept 58, further including:

- 20 advancing a first anchor through the lumen of the tube subsequently to steering the tube toward the first location,
 anchoring the annuloplasty structure at the first location thereof to the annulus by advancing the first anchor through the annuloplasty structure and into tissue of the annulus,
- 25 advancing a second anchor through the lumen of the tube subsequently to steering the tube toward the second location, and
 anchoring the annuloplasty structure to the annulus at the second location thereof by advancing the second anchor through the annuloplasty structure and into tissue of the annulus.

30 61. The method according to inventive concept 58, wherein the annuloplasty structure includes at least one elongate structure, and wherein advancing toward the valve the at

least one annuloplasty structure includes advancing toward the valve the at least one elongate structure.

62. The method according to inventive concept 61, wherein advancing toward the valve the at least one elongate structure includes advancing toward the valve the at least one elongate structure in a substantially linear configuration thereof.

63. The method according to inventive concept 62, further including pulling the elongate structure into a curved configuration following the advancing of the elongate structure toward the valve.

64. The method according to inventive concept 62, further including allowing the elongate structure to assume a curved configuration following the advancing of the elongate structure toward the valve.

65. A method for repairing a valve of a body of a patient, the valve including an annulus and at least first and second leaflets, including:

advancing a tube shaped to define a tube lumen toward the valve of the patient;

advancing toward the valve at least one annuloplasty structure reversibly coupled to the tube and at respective locations thereof to one or more longitudinal guide members at respective distal portions thereof, the one or more longitudinal guide members being disposed at least in part along a distal portion of the tube;

positioning the annuloplasty structure against the annulus of the patient; and

steering the distal portion of the tube toward a first location along the annuloplasty structure by pulling the one or more longitudinal guide members.

66. Apparatus, including:

a tubular structure having a lumen therein having a longitudinal axis;

a wire disposed at least in part within the lumen of the tubular structure;

at least one elongate tube configured to be reversibly coupled at a distal portion thereof to the tubular structure; and

an extension coupled at a proximal portion thereof to the distal portion of the elongate tube, a distal portion of the extension being configured to be disposed within the lumen of the tubular structure and to surround at least a portion of the wire that is disposed at least in part within the lumen of the tubular structure.

67. The apparatus according to inventive concept 66, wherein the tubular structure includes an annuloplasty structure.
68. The apparatus according to inventive concept 66, wherein the tubular structure includes at least one subunit that is compressible along a longitudinal axis of the tubular structure.
69. The apparatus according to inventive concept 66, wherein the tubular structure includes a braided mesh.
70. The apparatus according to inventive concept 66, wherein the tubular structure includes at least one anchor mount having a longitudinal axis thereof that is transverse to the longitudinal axis of the tubular structure, and wherein the anchor mount is shaped to provide at least one first channel aligned along the longitudinal axis of the anchor mount.
71. The apparatus according to inventive concept 70, wherein the at least a first channel includes first and second channels, wherein the anchor mount is shaped to provide the first channel in a vicinity adjacent to the second channel.
72. The apparatus according to inventive concept 71, wherein the distal portion of the channel is configured to be disposed within the second channel.
73. The apparatus according to inventive concept 71, wherein the distal portion of the elongate tube is configured to be disposed proximally to the first channel of the anchor mount.
74. The apparatus according to inventive concept 73, further including at least one anchor configured to anchor the tubular structure to tissue of a patient, wherein the anchor is configured to be:
advanced toward the tubular structure via the elongate tube,
advanced through the first channel of the anchor mount, and
implanted within the tissue.
75. The apparatus according to inventive concept 66, further including a ratchet mechanism configured to be disposed within the lumen of the tubular structure, the ratchet mechanism including a body portion, a first end shaped to define at least one first engaging structure, and a second end shaped to define at least one second engaging structure configured to engage the first engaging structure, wherein the ratchet mechanism is configured to maintain a ratcheted perimeter of the tubular structure.

76. The apparatus according to inventive concept 75, wherein:

the body portion is shaped to define at least one tubular body portion having at least one lumen therein,

5 the apparatus further includes a wire disposed at least in part within the lumen of the body portion, and

the tubular structure is configured to be advanced toward a left atrium of a patient in a generally straight configuration and subsequently to assume a curved configuration in response to a contracting force applied thereto by contraction of the wire.

77. The apparatus according to inventive concept 75, wherein:

10 the body portion is shaped to define a flat body portion,

the apparatus further includes a wire disposed at least alongside the body portion, and

15 the tubular structure is configured to be advanced toward a left atrium of a patient in a generally straight configuration and subsequently to assume a curved configuration in response to a contracting force applied thereto by contraction of the wire.

78. Apparatus, including:

a tubular structure having a lumen thereof having a longitudinal axis;

20 at least one anchor mount coupled to the tubular structure, the anchor mount being shaped to provide at least one channel having a longitudinal axis that is at a non-zero angle with respect to the longitudinal axis of the tubular structure; and

25 a ratchet mechanism configured to be disposed within the lumen of the tubular structure, the ratchet mechanism including a body portion, a first end shaped to define at least one first engaging structure, and a second end shaped to define at least one second engaging structure configured to engage the first engaging structure, the ratchet mechanism configured to maintain a ratcheted perimeter of the tubular structure.

79. The apparatus according to inventive concept 78, wherein the tubular structure includes a braided mesh.

80. The apparatus according to inventive concept 78, wherein the tubular structure includes an annuloplasty structure.

81. The apparatus according to inventive concept 78, wherein the tubular structure includes at least one subunit that is compressible along the longitudinal axis of the tubular lumen.
82. The apparatus according to inventive concept 78, wherein the tubular structure is
5 configured for transcatheter advancement into an atrium of a heart of a patient.
83. The apparatus according to inventive concept 78, wherein the tubular structure includes a shape-memory alloy, the alloy being configured to assume a curved configuration once the structure has been advanced into a left atrium of a patient.
84. The apparatus according to inventive concept 78, wherein the at least one anchor
10 mount includes two or more anchor mounts, and wherein the tubular structure includes at least one subunit disposed between the two or more anchor mounts, the subunit being compressible along the longitudinal axis of the tubular lumen.
85. The apparatus according to inventive concept 78, wherein the anchor mount is
15 shaped to define an anchor mount lumen having a longitudinal axis that is parallel with respect to the longitudinal axis of the tubular structure, and wherein the channel is disposed at the non-zero angle with respect to the longitudinal axis of the anchor mount lumen.
86. The apparatus according to inventive concept 85, wherein the ratchet mechanism
20 is configured to be disposed within the lumen of the tubular structure and within the anchor mount lumen.
87. The apparatus according to inventive concept 86, further including a wire disposed at least in part within the lumen of the tubular structure and within the anchor mount lumen.
88. The apparatus according to inventive concept 86, wherein:
25 the body portion of the ratchet mechanism is shaped to define at least one tubular body portion having at least one lumen therein,
the apparatus further includes a wire is disposed at least in part within the lumen of the body portion, and
the tubular structure is configured to be advanced toward an atrium of a heart of a
30 patient in a generally straight configuration and subsequently to assume a curved configuration in response to a contracting force applied thereto by contraction of the wire.

89. The apparatus according to inventive concept 86, wherein the tubular structure includes at least one subunit that is compressible along a longitudinal axis of the tubular structure.
90. The apparatus according to inventive concept 86, wherein:
5 the body portion is shaped to define a flat body portion,
the wire is disposed at least alongside the body portion, and
the tubular structure is configured to be advanced toward an atrium of a heart of a patient in a generally straight configuration and subsequently to assume a curved configuration in response to a contracting force applied thereto by contraction of the wire.
- 10 91. The apparatus according to inventive concept 86, wherein the anchor mount lumen has a major axis that is (a) transverse with respect to the longitudinal axis of the anchor mount lumen and (b) at a non-zero angle with respect to the longitudinal axis of the first channel.
92. The apparatus according to inventive concept 91, wherein:
15 the apparatus includes a plurality of anchor mounts,
each anchor mount of a first portion of the plurality of anchor mounts has a respective anchor mount lumen having a major axis that is disposed at a first angle with respect to the longitudinal axis of the channel, and
each anchor mount of a second portion of the plurality of anchor mounts has a
20 respective anchor mount lumen having a major axis that is disposed at a second angle with respect to the longitudinal axis of the channel.
93. The apparatus according to inventive concept 78, further including a wire disposed at least in part within the lumen of the tubular structure, wherein the tubular structure is configured to be advanced toward an atrium of a heart of a patient in a generally straight
25 configuration and subsequently to assume a curved configuration in response to a contracting force applied thereto by contraction of the wire.
94. The apparatus according to inventive concept 93, wherein the ratchet mechanism is configured to be advanced toward the atrium of the patient in a generally straight configuration and subsequently to assume a curved configuration in response to the
30 contracting force.
95. The apparatus according to inventive concept 93, wherein, in response to the contracting force, the wire is configured to draw together opposite ends of the ratchet

mechanism and opposing ends of the tubular structure, and wherein the ratchet mechanism is configured to maintain respective first ratcheted perimeters of the tubular structure and the ratchet mechanism.

5 96. The apparatus according to inventive concept 95, wherein, in response to an additional contracting force by additional contraction of the wire, the wire is configured to contract the ratchet mechanism and the tubular structure to respective second ratcheted perimeters thereof, each second ratcheted perimeter being smaller than the respective first ratcheted perimeters, and wherein the ratchet mechanism is configured to maintain the respective second ratcheted perimeters of the ratchet mechanism and the tubular structure.

10 97. The apparatus according to inventive concept 78, further including a plurality of longitudinal guide members, wherein each guide member is removably coupled to the tubular element and is configured to facilitate anchoring of the tubular structure to the annulus of the patient.

15 98. The apparatus according to inventive concept 97, wherein a distal end of the longitudinal guide member is coupled to the tubular element in a vicinity of the anchor mount.

99. The apparatus according to inventive concept 97, further including a bar configured to be disposed within the channel.

20 100. The apparatus according to inventive concept 99, further including at least one anchor configured to be guided toward the anchor mount via the longitudinal guide member and advanced through the channel of the anchor mount, around the bar, and into tissue of an annulus of the patient.

25 101. The apparatus according to inventive concept 100, wherein the longitudinal guide member is configured to be looped around the bar and to be decoupled from the bar following the advancement of the anchor into the annulus.

102. The apparatus according to inventive concept 99, wherein the bar is disposed within the channel angularly with respect to an axis of the channel.

103. The apparatus according to inventive concept 102, wherein the bar is disposed within the channel substantially parallel to the longitudinal axis of the tubular lumen.

30 104. The apparatus according to inventive concept 97, wherein the at least one anchor mount includes two or more anchor mounts, and wherein the at least one longitudinal

guide member includes two or more longitudinal guide members having respective distal ends thereof configured to be reversibly coupled to the tubular structure.

105. The apparatus according to inventive concept 104, wherein each one the two or more anchor mounts has a longitudinal axis thereof that is transverse to the longitudinal axis of the tubular structure, and wherein each mount shaped to provide a channel aligned along the longitudinal axis of the respective anchor mount.

106. The apparatus according to inventive concept 105, wherein:

the apparatus further includes an elongate tube shaped to define an elongate tube lumen, the elongate tube being configured to be coupled to the tubular structure, and

10 the two or more longitudinal guide members are aligned in parallel with the elongate tube and coupled to a distal portion of the tube, the longitudinal guide members having distal ends thereof configured to be reversibly coupled to the tubular structure, and arranged in a manner in which:

15 application of a force to a first one of the longitudinal guide members steers the distal portion of the elongate tube toward a first location along the tubular structure, and

application of a force to a second one of the longitudinal guide members steers the distal portion of the elongate tube toward a second location along the tubular structure.

20 107. The apparatus according to inventive concept 106, wherein:

the first location includes a second one of the two or more anchor mounts,

the second location includes a second one of the two or more anchor mounts,

a respective one of the two or more longitudinal guide members is reversibly coupled to each of the two or more anchor mounts, and

25 application of the force to the first one of the longitudinal guide members steers the distal portion of the elongate tube toward the first anchor mount, and application of the force to the second one of the longitudinal guide members steers the distal portion of the elongate tube toward the second anchor mount.

30 108. The apparatus according to inventive concept 107, further including at least one anchor configured to be advanced through the lumen of the elongate tube, wherein the anchor is configured to be advanced through the channel of a first one of the two or more

anchor mounts in response to steering the distal portion of the elongate tube toward the anchor mount by applying the force to the first one of the longitudinal guide members.

109. Apparatus, including:

a tubular structure having a lumen therein having a longitudinal axis;

5 a wire disposed in part within the lumen of the tubular structure, the wire having first and second portions thereof, the first and second portions of the wire being disposed externally to the lumen of the tubular structure; and

10 a handle assembly including at least one rotating element configured to be coupled to the first and second ends of the wire, in a manner in which rotation of the rotating element applies a force to the wire disposed within the tubular structure and adjusts a perimeter of the tubular structure.

110. The apparatus according to inventive concept 109, wherein the tubular structure includes an annuloplasty structure.

111. The apparatus according to inventive concept 109, wherein the tubular structure 15 includes at least one subunit that is compressible along a longitudinal axis of the tubular structure.

112. The apparatus according to inventive concept 109, wherein the tubular structure includes at least one anchor mount coupled to the tubular structure, the anchor mount having a longitudinal axis that is transverse to the longitudinal axis of the tubular structure 20 and shaped to provide a channel aligned along the longitudinal axis of the anchor mount.

113. The apparatus according to inventive concept 109, wherein the tubular structure includes a braided mesh.

114. The apparatus according to inventive concept 109, wherein:

25 in response to a rotation of the rotating element, the wire is configured to contract the tubular structure to a first perimeter thereof, and

in response to an additional rotation of the rotating element, the wire is configured to contract the tubular structure to a second perimeter thereof, the second perimeter being smaller than the first perimeter.

115. The apparatus according to inventive concept 109, further including a ratchet 30 mechanism configured to be disposed within the lumen of the tubular structure, the ratchet mechanism including a body portion, a first end shaped to define at least one first

engaging structure, and a second end shaped to define at least one second engaging structure configured to engage the first engaging structure, wherein the ratchet mechanism is configured to maintain a ratcheted perimeter of the tubular structure.

116. The apparatus according to inventive concept 115, wherein:

5 in response to a first contracting force by contraction of the wire, the wire is configured to contract the ratchet mechanism and the tubular structure to respective first ratcheted perimeters thereof,

10 in response to a second contracting force by additional contraction of the wire, the wire is configured to contract the ratchet mechanism and the tubular structure to respective second ratcheted perimeters thereof, each second ratcheted perimeter being smaller than the respective first ratcheted perimeters, and

the ratchet mechanism is configured to maintain the respective second ratcheted perimeters of the ratchet mechanism and the tubular structure.

117. The apparatus according to inventive concept 115, wherein:

15 the body portion is shaped to define at least one tubular body portion having at least one lumen therein,

the wire is disposed at least in part within the lumen of the body portion, and

20 the tubular structure is configured to be advanced toward a left atrium of a patient in a generally straight configuration and subsequently to assume a curved configuration in response to a contracting force applied thereto by contraction of the wire.

118. The apparatus according to inventive concept 115, wherein:

the body portion is shaped to define a flat body portion,

the wire is disposed at least alongside the body portion, and

25 the tubular structure is configured to be advanced toward a left atrium of a patient in a generally straight configuration and subsequently to assume a curved configuration in response to a contracting force applied thereto by contraction of the wire.

119. Apparatus for use with tissue of a patient, including:

30 a housing having a lateral wall having a proximal and a distal portion, the lateral wall being shaped to define a channel extending from a first opening in the proximal portion to a second opening in the distal portion, the channel having a longitudinal axis thereof; and

an anchor structure configured for passage through the channel and into the tissue, including:

a plurality of coils; and

a head portion defining a diameter of the structure that is larger than a diameter of the first opening, the head portion configured to:

restrict distal motion of the plurality of coils beyond a predetermined depth by abutting against the first opening of the proximal portion, and

draw tissue proximally by rotation of the head portion around the longitudinal axis of the channel.

120. Apparatus, including:

a tubular implant shaped to define an implant lumen;

a flexible longitudinal member disposed within the implant lumen, the flexible longitudinal member having a first end that is slidable with respect to a second end thereof to form the longitudinal member into a closed loop having a perimeter thereof which (a) shortens when the first end is advanced in a first direction with respect to the second end in a first direction, and (b) expands when the first end is advanced with respect to the second end in a second direction opposite to the first direction; and

a flexible contracting member being disposed alongside the longitudinal member and within and slidably advanceable through the implant lumen to facilitate reduction of the perimeter of the longitudinal member by application of a compression force to the longitudinal member.

121. The apparatus according to inventive concept 120, wherein the contracting wire facilitates sliding of the first end of the flexible member with respect to the second end in the second direction, even in the absence of a force applied to the contracting wire.

122. The apparatus according to inventive concept 120, wherein, in response to a pulling force applied to the contracting member, the flexible member is configured to facilitate compression of the implant, and responsively to the compression of the implant, to facilitate sliding of the first end of the longitudinal member with respect to the second end in the first direction.

123. The apparatus according to inventive concept 120, wherein:

when formed into the closed loop, the longitudinal member is shaped to provide an inner surface and an outer surface with respect to a center of the closed loop,

the flexible contracting member is disposed alongside the longitudinal member externally to the outer surface thereof, and

5 in response to the pulling force applied to the contracting wire, the contracting wire is configured to facilitate sliding of the first end of the longitudinal member with respect to the second end in the first direction.

124. A method, including:

providing:

10 a tubular implant having an implant lumen,

a flexible longitudinal member disposed within the implant lumen, the flexible longitudinal member having a first end that is slidable with respect to a second end thereof, and

15 a flexible contracting member being disposed alongside the longitudinal member and within and slidably advanceable through the implant lumen, the flexible longitudinal member having a first end that is slidable with respect to a second end thereof to form the longitudinal member into a closed loop having a perimeter thereof which (a) shortens when the first end is advanced in a first direction with respect to the second end in a first direction, and (b) expands when
20 the first end is advanced with respect to the second end in a second direction opposite to the first direction; and

reducing the perimeter of the longitudinal member by applying a compression force to the longitudinal member.

125. The method according to inventive concept 124, further comprising facilitates
25 sliding of the first end of the flexible member with respect to the second end in the second direction, even in the absence of a force applied to the contracting wire.

126. The method according to inventive concept 124, further comprising applying a pulling force to the contracting member, and wherein applying the compression force to the longitudinal member comprises:

30 responsively to the applying the pulling force to the contracting member, compressing the implant, and

responsively to the compressing the implant:

applying the compression force to the longitudinal member,
facilitating sliding of the first end of the longitudinal member with respect
to the second end in the first direction; and
compressing the longitudinal member.

5 127. The method according to inventive concept 124, wherein:

the method further comprises forming the longitudinal member into the closed
loop wherein the flexible member has an inner surface and an outer surface with respect to
a center of the closed loop, and the flexible contracting member is disposed alongside the
longitudinal member externally to the outer surface thereof, and

10 reducing the perimeter of the longitudinal member comprises:

applying a pulling force to the contracting wire, and
responsively to the applying the pulling force, facilitating sliding of the
first end of the longitudinal member with respect to the second end in the first
direction.

15 The present invention will be more fully understood from the following detailed
description of embodiments thereof, taken together with the drawings, in which:

BRIEF DESCRIPTION OF THE DRAWINGS

Fig. 1 is a schematic illustration of an annuloplasty structure comprising a ratchet mechanism, in accordance with an embodiment of the present invention;

5 Figs. 2A-B are schematic illustrations of a ratchet mechanisms for use with an annuloplasty structure, in accordance with respective embodiments of the present invention;

Fig. 3 is a schematic illustration of the ratchet mechanism of Fig. 2A coupled to an anchor mount, in accordance with an embodiment of the present invention;

10 Fig. 4 is a schematic illustration of an anchor coupled to the anchor mount of Fig. 3, in accordance with an embodiment of the present invention;

Figs. 5A-C are schematic illustrations of the ratchet mechanism of Fig. 2A coupled to an anchor mount, in accordance with another embodiment of the present invention;

15 Figs. 6A-B and 7 are schematic illustrations of a ratchet mechanism for use with an annuloplasty structure, in accordance with respective embodiments of the present invention;

Figs. 8-10 are schematic illustrations of a mount for use in anchoring an annuloplasty structure to the annulus of the patient, in accordance with respective embodiments of the present invention;

20 Fig. 11 is a schematic illustration of a channel for use in combination with an annuloplasty structure and for passage therethrough of an anchor in order to anchor the annuloplasty structure to the annulus of the patient, in accordance with an embodiment of the present invention;

25 Figs. 12, 13A-E, 14A-B, and 15 are schematic illustrations of anchors for anchoring an annuloplasty structure to the annulus of the patient, in accordance with respective embodiments of the present invention;

Figs. 16A-B are schematic illustrations of an anchor advancement structure, in accordance with an embodiment of the present invention;

Figs. 17A-J are schematic illustrations of transcatheter advancement and deploying of a system for repairing an annulus of the patient, in accordance with an embodiment of the present invention;

5 Figs. 18A-B are schematic illustrations of the deployment of two annuloplasty ring segments of the system toward the annulus of the patient, in accordance with an embodiment of the present invention;

Figs. 19A-E are schematic illustrations of an anchoring apparatus comprising a steerable catheter configured to facilitate anchoring of the two annuloplasty ring segments to the annulus of the patient, in accordance with an embodiment of the present invention;

10 Figs. 20A-B are schematic illustrations of the anchoring apparatus configured to anchor the two annuloplasty ring segments to the annulus of the patient, in accordance with an embodiment of the present invention;

Figs. 21-22 are schematic illustrations of a handle for anchoring an annuloplasty structure to the annulus of the patient, in accordance with an embodiment of the present
15 invention; and

Figs. 23A-B are schematic illustrations of an annuloplasty structure comprising a ratchet mechanism, in accordance with still yet another embodiment of the present invention.

DETAILED DESCRIPTION OF THE EMBODIMENTS

Reference is now made to Fig. 1, which is a schematic illustration of an annuloplasty structure 100, e.g., at least one elongate segment or tubular element, comprising a plurality of compressible subunits 450 and a plurality of anchor mounts 461, in accordance with an embodiment of the present invention. Structure 100 comprises a modular annuloplasty structure in which the plurality of compressible subunits 450 are alternately disposed with respect to the plurality of anchor mounts 461. Typically, structure 100 comprises an implant shaped to define a tubular structure having a cross-section of any suitable shape, e.g., circular or elliptical. Compressible subunits 450 are shaped to define a hollow lumen and comprise a braided mesh 452 (e.g., wire or polyester), by way of illustration and not limitation. For example, compressible subunits 450 may comprise a plurality of coils, braided structures, stent-shaped struts, or accordion- or bellows-shaped structures. A ratchet mechanism 600 (described hereinbelow with reference to Figs. 6A-B) is disposed within the hollow lumen of structure 100. Ratchet mechanism 600 comprises a ratchet body 202 having a fixed end 210 and a dynamic end 220. Although ratchet mechanism 600 is shown as being used in combination with structure 100, it is to be noted that any of the ratchet mechanisms described herein may be used in combination with structure 100.

Typically compressible subunits 450 and anchor mounts 461 comprise a biocompatible material, e.g., nitinol, ePTFE, PTFE, stainless steel, platinum iridium, titanium, or cobalt chrome. In some embodiments, compressible subunits 450 and anchor mounts 461 are coated with PTFE (Polytetrafluoroethylene). In some embodiments, compressible subunits 450 function as accordion- or bellows-shaped compressible structures which facilitate proper cinching of the annulus when structure 100 is contracted. The configuration of the annulus of the mitral valve differs from patient to patient. Compressible subunits 450, when compressed, e.g., typically along a longitudinal axis of structure 100, enable respective portions of annuloplasty structure 100 to independently conform to the configuration of each portion of the annulus that is in alignment with a given portion of the annuloplasty structure.

It is to be noted that for some applications, annuloplasty structure 100 is shaped to define a single tubular structure independently of the plurality of anchor mounts 461. In such an embodiment, the single tubular structure comprises an elongate sheath of

compressible material, as described hereinabove with respect to compressible subunits 450.

5 A contracting wire (not shown) is disposed within the lumen of structure 100 generally alongside ratchet body 202. Typically, pulling on the contracting wire controls the structural configuration of ratchet body 202 which in turn controls the structural configuration of structure 100, as will be described hereinbelow. In response to the pulling of the wire, an inward radial force is applied to structure 100, and a perimeter of structure 100 is modulated, i.e., reduced.

10 The contracting wire comprises a flexible and/or superelastic material, e.g., nitinol, polyester, PTFE, ePTFE, stainless steel, or cobalt chrome, and is configured to reside chronically within structure 100. In some embodiments, the contracting wire comprises a braided polyester suture (e.g., Ticon). In some embodiments, the contracting wire is coated with polytetrafluoroethylene (PTFE). In some embodiments, the contracting wire comprises a plurality of wires that are intertwined to form a rope structure.

15 Typically, structure 100 is shaped to provide at least one longitudinal lumen for passage therethrough of ratchet body 202 and the contracting wire. In some embodiments, structure 100 is shaped to provide a first longitudinal lumen passage therethrough of the contracting wire and a second longitudinal lumen for passage therethrough of ratchet body 202.

20 Fixed end 210 is fixed within a substantially tubular ratchet-coupling housing 610, while dynamic end 220 slides through housing 610 along a track 642 in the direction as indicated by the arrow. Ratchet body 202 is shaped to define a plurality of first engaging structures, e.g., first grooves 620, which are engageable by a tooth 612 of housing 610. As dynamic end 220 is slid away from fixed end 210 (i.e., in the direction as indicated by the arrow), grooves 620 are engaged by a second engaging structure, e.g., tooth 612, thereby allowing ratchet body 202 to slide in only one direction, i.e., the direction in which dynamic end 220 is first fed through housing 610 and as indicated by the arrow. As dynamic end 220 advances beyond fixed end 210, dynamic end 220 slides alongside the portion of body 202 that is adjacent to fixed end 210.

30 Each anchor mount 461 is shaped to provide at least one longitudinal anchor mount lumen having an axis that is parallel with the longitudinal axis of the annuloplasty structure. The anchor mount lumen facilitates passage therethrough of ratchet body 202

and the contracting wire. In some embodiments, each anchor mount 461 is shaped to provide a first longitudinal lumen passage therethrough of the contracting wire and a second longitudinal lumen for passage therethrough of ratchet body 202.

Each anchor mount 461 is shaped to provide an anchor channel for passage
5 therethrough of a helical anchor 740. As will be described hereinbelow, the channel is shaped to define a lumen having a channel axis that is disposed at a non-zero angle, e.g., transverse, with respect to a longitudinal axis of the longitudinal lumen of the anchor mount through which ratchet body 202 and the contracting wire pass. As such, in response to pulling of the contracting wire, the resultant sliding of portions of the
10 contracting wire and of ratchet body 202 through the longitudinal lumen mount 461, does not interfere with the anchor channel and anchor 740 disposed therein. The angle of the anchor channel with respect to the longitudinal lumen of anchor mount 461 facilitates corkscrewing of the anchor into the annulus of the valve of the patient at an angle as defined by the intersecting axes of the anchor channel and the longitudinal lumen of
15 mount 461, as described hereinbelow with reference to Fig. 8.

Typically, for embodiments in which annuloplasty structure 100 comprises a plurality of anchor mounts 461, the respective angles defined by the intersecting axes of each anchor channel with the respective axis of the longitudinal lumen of each mount 461 is identical for all mounts 461. Alternatively, a first portion of the plurality of anchor
20 mounts 461 has an angle that differs from the angle of a second portion of the plurality of anchor mounts. For example, a portion of anchor mounts 461 designated to be anchored to the anterior portion of the annulus has an angle that is different from a portion of anchor mounts 461 designated to be anchored to the posterior portion of the annulus. Thus, the anchors may be anchored to different portions of the annulus at different angles
25 in response to a need therefor.

It is to be noted that although helical anchors 740 are used in combination with structure 100, any anchor described herein may be used in combination with structure 100.

For embodiments in which structure 100 is implanted during an open-heart or
30 minimally-invasive procedure, structure 100 is advanced toward the valve in a closed configuration (e.g., substantially ring-shaped or "D"-shaped), as shown. It is to be noted that structure 100 may be advanced toward the valve of the patient in a linear

configuration during an open-heart or minimally-invasive valve repair procedure. In such an embodiment, once structure 100 is properly positioned within the left atrium of the heart, the contracting wire (not shown) is pulled and first and second ends 102 and 104 of annuloplasty structure 100 are drawn toward each other such that structure 100 assumes its closed configuration.

For embodiments in which structure 100 is advanced during a percutaneous valve repair procedure, structure 100 is manufactured having a first end 102 that is typically coupled to, e.g., welded to, housing 610 and a second end 104 that is not coupled to housing 610 during the advancing. Thus, structure 100, in such an embodiment, is advanced toward the left atrium of the patient in a generally linear configuration thereof.

For embodiments in which structure 100 is advanced toward the valve in a linear configuration, second end 104 is coupled to an engaging structure configured to engage housing 610 as structure 100 is made to assume its closed configuration. In some embodiments, the engaging structure coupled to second end 104 comprises a tube having a diameter that is smaller than an inner diameter of housing 610 and is configured to slide within housing 610 as structure 100 is drawn into its closed configuration.

Housing 610 comprises first and second coupling sites 650 and 660, for coupling of first end 102 and second end 104 of structure 100, respectively, to housing 610.

It is to be noted that annuloplasty structure 100 may be used independently of ratchet mechanism 600. For example, annuloplasty structure 100 may comprise only the contracting wire passing through the lumen of structure 100. In such an embodiment, once annuloplasty structure 100 is deployed from its linear state, the respective ends of the contracting wire are: (1) pulled such that the annuloplasty structure assumes its closed configuration, and (2) locked together in order to maintain the closed configuration.

As described herein, structure 100 typically comprises a braided mesh in embodiments in which sutures pass through structure 100 and facilitate anchoring or suturing of structure 100 to the annulus. For embodiments in which annuloplasty structure 100 is positioned using an open-heart procedure, the mesh facilitates suturing of structure 100 to the annulus of the patient. In such an embodiment, the physician passes the suture through the mesh at a first location thereof, through tissue of the annulus, and subsequently, through a second location of the mesh, thereby suturing structure 100 to the annulus. In some embodiments, the suturing is performed following placement of the

annuloplasty structure along the annulus. In some embodiments, a plurality of sutures are sutured to the annulus of the patient and the annuloplasty structure is slid along the sutures and toward the annulus. In such an embodiment, respective ends of each of the plurality of sutures are threaded through the mesh prior to the sliding, and are knotted together and clipped following the sliding. The knotting of the sutures maintains the positioning of the annuloplasty structure along the annulus.

For some embodiments, the mesh facilitates anchoring of the annuloplasty structure to the annulus of the patient. In such an embodiment, the physician passes the anchor through the mesh at a first location thereof and then through tissue of the annulus.

It is to be understood that the braided mesh may be used independently of or in combination with the compressible subunits and/or with the anchor mounts. For example, the mesh may surround at least compressible subunits 450 of structure 100. Alternatively, the braided mesh may be used independently of compressible subunits 450 and/or anchor mounts 461. In such an embodiment, structure 100 may comprise only ratchet mechanism 600 and/or the contracting wire surrounded by a sheath of braided mesh.

Reference is now made to Fig. 2A, which is a schematic illustration of a flat-ribbon ratchet mechanism 200, in accordance with an embodiment of the present invention. Typically, ratchet mechanism 200 is used in combination with annuloplasty structure 100 as described hereinabove with reference to Fig. 1, in accordance with an embodiment of the present invention. It is to be noted that ratchet mechanism 200 may be used in combination with any of the annuloplasty structures described herein. Ratchet mechanism 200 comprises a ratchet body 202 defining a flat ribbon having a proximal fixed end 210 and a distal dynamic end 220. Although Fig. 1 shows ratchet mechanism 600 disposed within annuloplasty structure 100, it is to be noted that ratchet mechanism 200 may be disposed within annuloplasty structure 100. Ratchet mechanism 200 is disposed within the lumen of structure 100 such that fixed end 210 is disposed within the lumen of structure 100 in the vicinity of first end 102 thereof, and dynamic end 220 is disposed within the lumen of structure 100 in the vicinity of second end 104 thereof.

As described hereinabove, in some embodiments, structure 100 is advanced toward the left atrium of the patient in a generally linear configuration. Although ratchet body 202 is shown in a linear configuration, it is to be noted that ratchet body 202 is later drawn into a closed configuration (e.g., substantially ring-shaped or "D"-shaped

configuration) simultaneously with structure 100 assuming its closed configuration (e.g., substantially ring-shaped or "D"-shaped configuration). As the contracting wire is pulled and first and second ends 102 and 104 of annuloplasty structure 100 are drawn toward each other such that structure 100 assumes its closed configuration, dynamic end 220 is advanced past fixed end 210 such that ratchet body 202 assumes its closed configuration as well. As dynamic end 220 advances beyond fixed end 210, dynamic end 220 and the distal portion of body 202 are slid alongside fixed end 210 and the proximal portion of body 202. Dynamic end 220 and fixed end 210 are able to meet each other due to the sliding of ratchet body 200 along a track within the a respective lumen of each anchor mount 461 of structure 100, as will be described hereinbelow.

Ratchet body 202 is shaped to define a plurality, e.g., at least two as shown, of first engaging structures, e.g., first windows 204, in the vicinity of dynamic end 220 and a plurality of second windows 206 in the general vicinity of the middle of ratchet body 202. It is to be noted that the number of second windows 206 is shown by way of illustration and not limitation. Fixed end 210 is shaped to define a second engaging structure, e.g., a tooth 230, which projects angularly away from a longitudinal axis of ratchet body 202 and is configured to engage the first engaging structures, e.g., windows 204 and 206. Fixed end 210 is shaped to define a slit 240 surrounding tooth 230. As ratchet mechanism 200 is initially drawn into its closed configuration, dynamic end 220 slides alongside tooth 230 and slit 240 of fixed end 210.

Ratchet body 202 provides a portion 222 disposed between first windows 204 and second windows 206. Typically, portion 222 provides a smooth surface for unobstructed back and forth sliding of dynamic end 220 past fixed end 210 and enables the physician to adjust the size/perimeter of the annuloplasty structure before it is positioned along the annulus. Additionally, portion 222 enables the physician to adjust the size/perimeter of the ratchet mechanism 200 prior to being locked in place in response to the engaging of second windows 206 by tooth 230. Typically, portion 222 has a distance D_{i3} that is between 30 mm and 70 mm, e.g., 50 mm.

For embodiments in which ratchet mechanism 200 is disposed within structure 100, ratchet mechanism 200 is typically disposed alongside the portion of contracting wire 110 which is disposed within the lumen of structure 100. As structure 100 is pulled into its closed configuration in response to the pulling of contracting wire 110, dynamic end 220 is pulled toward fixed end 210. Dynamic end 220 is passively advanced alongside

fixed end 210 due to the compression force applied by structure 100 in response to the pulling of contracting wire 110. That is, dynamic end 220 is not pulled by contracting wire 110, rather it is passively pushed in response to the pulling of wire 110. Additionally, wire 110 is aligned alongside an external surface of ratchet body 202 and at an external perimeter thereof. In response to pulling of contracting wire 110, contracting wire 110 pushes against the external surface of ratchet body 202 and applies a compression force thereto. Responsively to the compression force of wire 110 on the external surface of ratchet body 202, ratchet body 202 passively compresses. Further additional pulling of wire 110 reduces the perimeter of ratchet mechanism 200, and thereby of structure 100.

In response to continued pulling of contracting wire 110, structure 100 radially contracts and, in turn, applies an additional compression force to ratchet mechanism 200. In response to the compression force to the ratchet mechanism by structure 100, ratchet body 202 radially contracts as dynamic end 220 is passively slid further distally away from fixed end 210 thereby drawing second windows 206 closer toward tooth 230 of fixed end 210. Dynamic end 220 is slid distally away from fixed end 210 until tooth 230 engages a first window 208 of second windows 206. Tooth 230 remains locked in position with respect to first window 208 until an additional compression force is applied to ratchet body 202 in response to additional pulling of contracting wire 110. This additional force slides dynamic end 220 even further away from fixed end 210 until tooth 230 engages a second window 209 of second windows 206. Tooth 230 prevents ratchet body 202 from sliding in an opposite direction with respect to the direction by which dynamic end 220 is fed beyond fixed end 210. Thus, second windows 206 maintain respective ratcheted perimeters of the now substantially ring-shaped or "D"-shaped ratchet body 202, and thereby maintain respective ratcheted perimeters of structure 100.

Alternatively, for some embodiments, dynamic end 220 is shaped to define one or more holes configured for looping of contracting wire 110 therethrough. In such an embodiment, dynamic end 220 is pulled in response to tensile force applied to contracting wire 110 as it is pulled. Additional force applied to wire 110 pulls ratchet mechanism 200 into a closed configuration, e.g., a substantially ring-shaped configuration.

For embodiments in which structure is advanced toward the left atrium in its closed configuration, prior to the advancing, the physician forms structure 100 into a closed configuration by advancing dynamic end 220 beyond fixed end 210 until first

windows 204 are in alignment with tooth 230 and ratchet body 202 locks in place. At this stage, structure 100 defines a generally ring-shaped structure having a relatively large perimeter. As described hereinabove, once positioned along the annulus of the patient, the physician pulls wire 110 and dynamic end 220 slides and is pushed further away from fixed end 210 until second windows 206 lock and maintain a reduced perimeter of ratchet body 202, and thereby, structure 100.

It is to be noted that the plurality of second windows 206 are provided such that ratchet body 202, and thereby structure 100, can lock in place and maintain respective ratcheted perimeters thereof. Thus, the length of ratchet mechanism 200 in its linear configuration, the locking mechanism of ratchet mechanism 200, and compressible subunits 450 described hereinabove are provided so as to enable annuloplasty structure 100 to accommodate various sizes of dilated annuli of given patients. Additionally, ratchet mechanism 200 facilitates: (1) positioning and anchoring structure 100 along the dilated annulus while body 202 (and thereby structure 100) has a first perimeter thereof, (2) contracting the dilated annulus in response to the contracting of body 202 (and thereby structure 100), and (3) maintaining the contracted state of the annulus while body 202 (and thereby structure 100) has a second perimeter thereof that is typically smaller than the first perimeter.

It is to be further noted that ratchet mechanism 200 is described herein as being used in combination with structure 100 by way of illustration and not limitation. For example, ratchet mechanism 200 may be surrounded by a tubular sheath comprising a braided mesh, e.g., metal or fabric such as polyester. The braided mesh facilitates passage of sutures or longitudinal guide members through the sheath in order to anchor or suture the sheath to the annulus. In some embodiments, during expansion of the sheath, by pulling on opposite ends thereof, the braided mesh is longitudinally pulled such that the mesh decreases in diameter, i.e., the transverse cross-sectional diameter that is perpendicular with respect to the longitudinal axis of structure 100. During contraction of the sheath from its relaxed state, the mesh is compressed such that the diameter of the mesh closely resembles the diameter of the mesh in its relaxed state.

Fig. 2B shows ratchet mechanism 200 as described hereinabove with respect to Fig. 2A, with the exception that fixed end 210 is shaped to define a housing 250, in accordance with an embodiment of the present invention. Typically, housing 250 of fixed end 210 is shaped to define tooth 230 and slit 240 and is configured to receive dynamic

end 220 in a manner as described hereinabove with respect to Fig. 2A. Typically, housing 250 is configured to provide stability to mechanism 200 during the aligning of windows 204 and 206 with tooth 230 of fixed end 210.

5 During the initial contraction of structure 100, dynamic end 220 is fed into housing 250. As described hereinabove, ratchet body 202 assumes a closed configuration as dynamic end 220 is initially locked in place when tooth 230 of housing 250 engages first windows 204. A compression force is further applied to ratchet body 202 (e.g., a radial force or a tensile force applied in response to pulling the contracting wire, as described hereinabove) which further advances dynamic end 220 away from housing 250.

10 Fig. 3 shows a system 300 comprising ratchet body 202 passing through a first one of anchor mounts 461 of annuloplasty structure 100, in accordance with an embodiment of the present invention. Anchor mount 461 comprises a lateral-aperture anchor mount 341 which comprises a substantially hollow, tubular element 463 configured for passage therethrough of ratchet body 202 and contracting wire 110. The anchor mount shown is
15 configured to fix in place fixed end 210 of ratchet body 202. It is to be noted that anchor mount 341 may fix in place any of the ratchet bodies described herein. Additionally, anchor mount 341 is shaped to define an aperture 340 configured for passage therethrough of an anchor, as will be described hereinbelow. In some embodiment, a tubular channel (configuration shown hereinbelow with reference to Fig. 4) for passage of an anchor is
20 coupled to, e.g., welded to, mount 341 along portions of mount 341 which define aperture 340. As shown, aperture 340 is provided at a location along mount 461 such that passage of a tissue anchor therethrough (e.g., directly or indirectly through a channel coupled to portions of mount 341 defining aperture 340), does not interfere with contracting wire 110 and/or ratchet body 202 disposed within the annuloplasty structure.

25 It is to be noted that only one anchor mount 341 is shown for clarity of illustration. For example, ratchet mechanism 200 may be coupled to a plurality of anchor mounts 341 which are disposed at various sites with respect to ratchet body 202. It is to be further noted that a respective compressible subunit 450 may be coupled to either end of anchor mount 341. As shown, anchor mount 461 is shaped to define a first coupling site 302 and
30 a second coupling site 304. For embodiments in which ratchet mechanism 300 is used in combination with compressible subunits 450, as described hereinabove with reference to Fig. 1, a respective compressible subunit 450 is coupled to coupling sites 302 and 304.

Reference is now made to Fig. 4, which is a schematic illustration of system 300 comprising a tissue anchor 360 coupled to anchor mount 341, in accordance with an embodiment of the present invention. Anchor mount 341 fixes in place fixed end 210 of ratchet body 202 as described herein. Ratchet body 202 of Fig. 3 is shown in an open, 5 linear configuration thereof, i.e., dynamic end 220 is not aligned alongside fixed end 210. An anchor 360 is shown coupled to mount 461. In some embodiments, a tube-channel 1200 (as described in more detail hereinbelow with reference to Fig. 11) is coupled to mount 461 portions of mount 341 defining aperture 340. In some embodiments, channel 1200 is welded to mount 461 during the manufacturing of mount 341.

10 In some embodiments, tube-channel 1200 is not welded to mount 341 but rather is advanced toward mount 341 together with, e.g., surrounding, anchor 360. In such an embodiment, channel 1200 is free to rotate with respect to aperture 340 along the longitudinal axis of mount 341.

As shown, anchor 360 is shaped to define a helix having a pointed distal end 370 15 which punctures through tissue of the annulus of the heart. It is to be noted that a helical anchor is shown by way of illustration and not limitation, and that any suitable anchor may be used to anchor the annuloplasty structure to the annulus. For embodiments in which a helical anchor is used, tube-channel 1200 may comprise a bar, as described in US Provisional Patent Application 61/001,013, PCT Patent Application PCT/IL07/001503, 20 and US Patent Application 11/950,930 to Gross et al., entitled, "Segmented ring placement". This bar is configured to restrict continued corkscrewing of helical anchor 360 into the tissue of the annulus beyond a predetermined distance, e.g., between 3 mm and 10 mm. Additionally, the bar functions as a nut providing a thread for the helical anchor to be advanced distally and corkscrewed around the bar and into the tissue of the 25 annulus.

As shown, helical anchor 360 is coupled at a proximal end thereof (i.e., the portion of anchor 360 that is not configured to be advanced into the annulus tissue) to a head portion 380. Typically, a distal end of head portion 380 has a diameter that is larger than a diameter of tube-channel 1200. Once anchor 360 is advanced distally through tube- 30 channel 1200, the distal portion of head portion 380 abuts a proximal portion of tube-channel 1200 and prevents continued distal motion of anchor 360. Even when head portion 380 abuts tube-channel 1200, anchor 360 is allowed to continue rotational motion. This continued rotational motion draws tissue of the annulus toward the annuloplasty

structure. In the event that a gap between the annulus tissue and the annuloplasty structure is created during the initial anchoring of the structure to the annulus of the valve, the continued rotation of anchor 360 minimizes and substantially eliminates the gap. As shown, head portion 380 is shaped to define one or more, e.g., two as shown, engaging elements, e.g., holes, 390. In some embodiments, engaging elements 390 are configured for coupling and/or passage therethrough of an actuation means by way of illustration and not limitation, and the anchoring means is configured to corkscrew the anchor into the tissue of the annulus.

It is to be noted that engaging elements 390 are shown as being circular by way of illustration and not limitation, and that elements 390 may be shaped to define any suitable shape, e.g., rectangles, ovals, etc.

Typically, head portion 380 prevents continued distal motion of anchor 360 into the annulus with respect to the distal surface of the anchor mount, i.e., the portion of the mount designated to align with and contact the annulus. For embodiments in which tube-channel 1200 is advanced together with anchor 360, the tube-channel 1200 rotates within aperture 340 along the longitudinal axis of mount 461 together with the rotating of anchor 360.

Reference is now made to Figs. 5A-C, which are schematic illustrations of system 300 as described hereinabove with reference to Fig. 4, with the exception that anchor mount 461 comprises a transverse-lumen anchor mount 342 comprising a tubular element 465 shaped to define an anchor lumen 501 having a longitudinal axis 502 thereof, in accordance with an embodiment of the present invention. Tubular element 465 fixes in place fixed end 210 of ratchet body 202 as described hereinabove with reference to Fig. 2A. Typically, anchor mount 461 provides at least one longitudinal anchor mount lumen having an axis that is parallel with the longitudinal axis of the annuloplasty structure. Anchor mount lumen facilitates passage therethrough of ratchet mechanism 200 and contracting wire 110. Longitudinal axis 502 of anchor lumen 501 is at a non-zero angle, e.g., transverse, with respect to the longitudinal axis of the anchor mount lumen of anchor mount 461. Transverse lumen 501 is shaped to facilitate passage therethrough of tube-channel 1200, as described hereinabove with reference to Fig. 4. As shown, transverse lumen 501 does not interfere with ratchet body 202 and contracting wire 110.

Reference is now made to Figs. 5A-B. Anchor mount 461 is coupled at either end thereof to a respective stabilizing structure 310. Typically, since anchor mount 461 comprises hollow tubular element 465, anchor mount 461 has a tendency to pivot laterally with respect to ratchet body 202. Stabilizing structure 310 is shaped to define mounts 312
5 which are configured to surround and lock in place a portion of anchor mount 461 and to prevent swiveling thereof. Ratchet body 202 passes through aperture 330 of stabilizing structure 310 and through the longitudinal anchor mount lumen. Passing of ratchet body 202 through structure 310 and then through mount 461 locks in place stabilizing structure 310 which, in turn, locks in place anchor mount 461 and prevents it from pivoting
10 laterally. Additionally, aperture 330 of stabilizing structure 310 provides a suitable track for advancement of ratchet body 202 along a defined path. For example, this track enables the proper positioning of dynamic end 220 with respect to fixed end 210.

Typically, aperture 330 has a major axis 331 and has a longitudinal axis 332 that is transverse with respect to major axis 331. Major axis 331 of aperture 330 is typically
15 disposed at a non-zero angle with respect to axis 502 of anchor lumen 501. A portion of ratchet body 202 passes through aperture 330 along longitudinal axis 332 thereof. Typically, ratchet body 202 passes through aperture 330 of a first stabilizing structure 310, through the lumen of anchor mount 461, and subsequently through aperture 330 of a second stabilizing structure 310. Prior to the coupling of mount 461 to a pair of structures
20 310, mount 461, and thereby lumen 501, is allowed to pivot laterally. Following the coupling of structures 310 to mount 461, structures 310 restrict the lateral pivoting of mount 461.

During the manufacture of structure 310, aperture 330 is created such that major axis 331 is disposed at a desired angle with respect to axis 502 of anchor lumen 501 when
25 coupled to mount 461. A portion of ratchet body 202 is then passed through mount 461 and subsequently through aperture 330, thereby fixing the angle of the major axis of aperture 330 with respect to axis 502 of anchor lumen 501. Typically, (a) longitudinal axis 332 of aperture 330 is substantially parallel with respect to a plane of the annulus and parallel with the longitudinal axis of the annuloplasty structure, and (b) axis 502 of anchor
30 lumen 501 is at a non-zero angle with respect to major axis 331 of the aperture 330. Thus, the angle of anchor lumen 501 with respect to longitudinal axis 332 facilitates corkscrewing of the tissue anchor into the annulus at an angle as defined by the

intersecting axes 502 of lumen 501 and major axis 331 of aperture 330 (shown in Fig. 5C).

For embodiments in which system 300 comprises a plurality of anchor mounts 461, the respective pairs of structures 310 coupled on either end of each mount 461 may be manufactured differently. For example, (1) a first pair of structures 310 may be shaped to define apertures 330 having a major axis at a first desired angle with respect to axis 502 of anchor lumen 501 of a first anchor mount 461, and (2) a second pair of structures 310 may be shaped to define apertures 330 having a major axis at a second desired angle with respect to the longitudinal axis of anchor lumen 501 of a second anchor mount 461. Thus, the respective anchors configured to be passed through each of the first and second anchor mounts are anchored to the tissue at the desired first and second angles, respectively. In some embodiments, the anchors which pass through the anchor mounts positioned along the annulus in alignment with the base of the posterolateral leaflet may be anchored at an angle that is different from an angle at which the anchors which pass through the anchor mounts positioned along the annulus in alignment with the base of the anteromedial leaflet are anchored.

Fig. 5C shows a perspective view of system 300 from an opposite view than that shown in Fig. 5A. Ratchet body 202 passes unobstructed alongside anchor lumen 501 of anchor mount 461. As described hereinabove, anchor mount 461 may also function as a housing for fixed end 210 of ratchet body 202. Anchor mount 461 is shaped to define a slit 520 which engages and fixes in place a portion 212 of fixed end 210. Typically, portion 212 projects away perpendicularly from a longitudinal axis of ratchet body 202.

Reference is now made to Figs. 3 and 5B-C. Anchor mount 461 is flanked by stabilizing structures 310. Fig. 5B shows a stabilizing unit 500 having a stabilizing structure 310 is shaped to define: (1) a hole 320 configured for passage therethrough of contracting wire 110, and (2) a longitudinal aperture 330 configured for passage therethrough of ratchet body 202, in accordance with an embodiment of the present invention. Typically, aperture 330 has a width L7 of between 0.3 mm and 0.8 mm. Such a width facilitates passage therethrough of at least a portion of ratchet body 202. For embodiments in which a first portion of body 202 is slid alongside a second portion of body 202 (e.g., dynamic end 220 slides alongside fixed end 210), width L7 accommodates for the widths of both the first and second portions of ratchet body 202 and facilitates passage therethrough of both portions.

Fig. 3 shows ratchet body 202 in a closed configuration thereof. It is to be noted that ratchet body 202 assumes a substantially circular configuration thereof and that only a portion of ratchet body 202 is shown. Typically, dynamic end 220 is passively fed through aperture 330 alongside fixed end 210. As such, a portion of body 202 distal to fixed end 210 aligns alongside a portion proximal to dynamic end 220, as shown in Fig. 3. Thus, width L7 of aperture 330 accommodates for the widths of: (1) the portion of body 202 distal to fixed end 210, and (2) the portion of body 202 proximal to dynamic end 220.

Reference is now made to Figs. 6A-B which are schematic illustrations of a ratchet mechanism 600, in accordance with an embodiment of the present invention. Ratchet body 202 is shaped to define dynamic distal end 220 and fixed proximal end 210. As shown, ratchet body 202 is shaped to define a plurality of first engaging structures, e.g., grooves 622, configured to be engaged by a second engaging structure, a tooth 612, at fixed end 210. Fixed end 210 is coupled to a substantially tubular ratchet-coupling housing 610 which is shaped to define a first coupling site 650 and a second coupling site 660. For embodiments in which ratchet mechanism 600 is used in combination with compressible subunits 450 as described hereinabove with reference to Fig. 1, a respective compressible subunit 450 is coupled to coupling sites 650 and 660.

As described hereinabove with reference to Fig. 1, ratchet mechanism 600 is disposed within the lumen of structure 100 such that fixed end 210 is disposed within the lumen of structure 100 in the vicinity of first end 102 thereof and dynamic end 220 is disposed within the lumen of structure 100 in the vicinity of second end 104 thereof. Although ratchet body 202 is shown in a linear configuration, it is to be noted that ratchet body 202 is drawn into its closed configuration simultaneously with structure 100 assuming its closed configuration. As contracting wire 110 is pulled and first and second ends 102 and 104 of annuloplasty structure 100 are drawn toward each other such that structure 100 assumes its closed configuration, dynamic end 220 is fed into housing 610 and is advanced past fixed end 210 such that ratchet body 202 assumes its closed configuration as well. As dynamic end 220 advances beyond fixed end 210, dynamic end 220 and the portion of body 202 that is proximal to end 220 are slid alongside fixed end 210 and the portion of body 202 that is distal to fixed end 210. As shown, housing 610 is coupled to an insert 640 that is shaped to define a longitudinal track 642. As dynamic end 220 is fed into housing 610 of fixed end 210, dynamic end slides along track 642. Thus,

dynamic end 220 and fixed end 210 are able to meet each other due to the sliding dynamic end 220 along track 642 within the lumen housing 610.

Ratchet body 202 is shaped to define a plurality, e.g., at least two as shown, of first grooves 620 in the vicinity of dynamic end 220 and a plurality of second grooves 630 in the general vicinity of the middle of ratchet body 202. It is to be noted that the respective numbers of first grooves 620 and second grooves 630 are shown by way of illustration and not limitation. As ratchet mechanism 600 is initially drawn into its closed configuration, dynamic end 220 slides alongside track 642 and tooth 612 engages respective grooves 622 of ratchet body 202.

Ratchet body 202 provides a portion 222 disposed between first grooves 620 and second grooves 630. Typically, portion 222 provides a smooth surface for unobstructed back and forth sliding through fixed end 210 and enables the physician to adjust the size/perimeter of the annuloplasty structure before it is positioned along the annulus. Additionally, portion 222 enables the physician to adjust the size/perimeter of ratchet mechanism 600 prior to the locking of second grooves 630 by tooth 612. Typically, portion 222 has a distance that is between 30 mm and 70 mm, e.g., 50 mm.

It is to be noted that ratchet mechanism 600 may be anchored to the annulus independently of annuloplasty structure 100 described hereinabove with reference to Fig. 1 and with reference to ratchet mechanism 200 described hereinabove with reference to Figs. 2A-B. Alternatively, for embodiments in which ratchet mechanism 600 is disposed within structure 100, ratchet mechanism 600 is typically disposed alongside the portion of contracting wire 110 which is disposed within the lumen of structure 100. As structure 100 is pulled into its closed configuration in response to the pulling of contracting wire 110, dynamic end 220 is pulled toward fixed end 210. Dynamic end 220 is passively advanced within housing 610, typically alongside fixed end 210, due to the compression force applied by structure 100 in response to the pulling of contracting wire 110.

In response to continued pulling of contracting wire 110, structure 100 radially contracts and, in turn, applies an additional compression force to ratchet mechanism 600. As described hereinabove, in response to the compression force, ratchet body 202 radially contracts as dynamic end 220 is passively slid further distally away from fixed end 210 thereby drawing second grooves 630 closer toward tooth 612 of housing 610. Dynamic end 220 is slid distally away from fixed end 210 until tooth 612 engages a first groove

624 of second grooves 630. Tooth 612 remains locked in position with respect to first groove 624 until an additional compression force of structure 100 is applied to ratchet body 202 (i.e., in response to the pulling of contracting wire 110). This additional force slides dynamic end 220 even further away from fixed end 210 until tooth 612 engages a second groove 626 of second grooves 630. Tooth 612 prevents body 202 of mechanism 600 from sliding in an opposite direction with respect to the direction by which dynamic end 220 is fed beyond fixed end 210. Thus, second grooves 630 maintain respective ratcheted perimeters of the now closed ratchet body 202, and thereby maintain respective ratcheted perimeters of structure 100.

10 For embodiments in which structure is advanced toward the left atrium in its closed configuration (e.g., during an open-heart procedure or during a minimally-invasive procedure), dynamic end 220 is advanced past fixed end 210 until first grooves 620 are in alignment with tooth 612 and ratchet body 202 is locked in an expanded configuration thereof and has a relatively large perimeter. As described hereinabove, once positioned
15 along the annulus of the patient, the dynamic end 220 is pushed further distally away (i.e., in the direction as indicated by the arrow in Fig. 6B) from fixed end 210 until locking grooves 630 lock and fix a perimeter of body 202, and thereby, fix a perimeter of structure 100.

It is to be noted that the plurality of second grooves 630 is provided such that ratchet body 202, and thereby structure 100, can lock in place and maintain respective ratcheted perimeters thereof. Thus, the length of ratchet mechanism 600 in its linear configuration, the locking mechanism of ratchet mechanism 600, and compressible subunits 450 described hereinabove are provided so as to enable annuloplasty structure 100 to accommodate various sizes of dilated annuli of given patients. Additionally,
25 ratchet mechanism 600 facilitates: (1) positioning and anchoring structure 100 along the dilated annulus while body 202 (and thereby structure 100) has a first perimeter thereof, (2) contracting the dilated annulus in response to the contracting of body 202 (and thereby structure 100), and (3) maintaining the contracted state of the annulus while body 202 (and thereby structure 100) has a second perimeter thereof that is typically smaller than
30 the first perimeter.

It is to be further noted that ratchet mechanism 600 is described as being used in combination with structure 100 by way of illustration and not limitation. For example,

ratchet mechanism 600 may be surrounded by a tubular sheath comprising a braided mesh, e.g., metal or fabric such as polyester.

Fig. 6B shows dynamic end 220 having already passed through housing 610 of fixed end 210. As such, ratchet body 202 assumes a closed configuration (partially shown for clarity of illustration). As shown, dynamic end 220 is shaped to define one or more holes 613 configured for looping of the contracting wire therethrough. In such an embodiment, dynamic end 220 is pushed in response to tensile force applied to the contracting wire as it is pulled. As described hereinabove, additional force applied to the contracting wire pushes ratchet mechanism 200 into a closed configuration, e.g., a substantially ring-shaped configuration. Further additional pulling of the contracting wire reduces the perimeter of ratchet mechanism 600, and thereby of the annuloplasty structure.

Fig. 7 shows ratchet mechanism 600 as described hereinabove with reference to Figs. 6A-B, with the exception that housing 610 provides a tooth 712 is shaped to define a window 714, in accordance with an embodiment of the present invention. Tooth 712 is coupled to housing 610 along a junction and bends along the junction. As tooth 712 engages groove 620 of ratchet body 202, window 714 surrounds a portion 772 of an upper surface 770 of ratchet body 202 which defines groove 620. Window 714 thus enables tooth 712 to advance distally and bend as far as possible within groove 620 without being obstructed by portion 772 of upper surface 770 which defines groove 620. Tooth 712 engages groove 620 and locks ratchet body 202 in place until an additional inward, radial pushing force is applied thereto, e.g., typically, in response to the pulling of contracting wire 110 described herein. In response to the additional inward, radial force applied to ratchet body 202, (a) dynamic end 220 is slid further away from housing 610 in the same direction in which dynamic end 220 was initially fed into housing 610 (i.e., the direction as indicated by the arrow), and (b) tooth 712 slides along upper surface 770 of ratchet body 202 until tooth 712 engages another groove 620 of ratchet body 202.

Dynamic end 220 is shaped to define one or more holes 613 configured for looping of the contracting wire therethrough. In such an embodiment, dynamic end 220 is pulled in response to tensile force applied to the contracting wire as it is pulled. Additional force applied to the contracting wire pulls ratchet mechanism 600 into the closed configuration. Further additional pulling of the contracting wire reduces the perimeter of ratchet mechanism 600, and thereby of the annuloplasty structure.

It is to be noted that ratchet body 202 may be pulled by contracting wire 110 in some embodiments. Ratchet body 202 is typically pushed in response to the radial, compressing force applied to body 202 by the annuloplasty structure in response to the pulling of contracting wire 110.

5 Reference is now made to Figs. 6A-B and 7. Fixed end 210 of ratchet body 202 is shaped to define a protrusion 722 (not shown in Figs. 6A-B). Housing 610 is shaped to define a slit (not shown for clarity of illustration) for passage therethrough of protrusion 722 in order to fix fixed end 210 in place with respect to housing 610.

Fig. 8 shows an anchor mount system 900 comprising an anchor mount 461
10 comprising a double-lumen anchor mount 343 that is shaped to define a channel 460 and a lumen 920, or channel, in accordance with an embodiment of the present invention. Anchor mount 461 is shaped to define a lateral wall 467 having a first portion 464 and a second portion 466 generally at opposite sites of mount 461 when viewed in cross-section (e.g., at 12 o'clock and 6 o'clock). Typically, first portion 464 is shaped to define an
15 opening thereof, and second portion 466 is shaped to define an opening thereof. Channel 460 extends from the opening of first portion 464, through the anchor mount, to the opening in second portion 466. As described hereinabove with reference to Fig. 1, anchor mount 461 is configured for facilitating passage therethrough any anchor described herein in order to facilitate anchoring of an annuloplasty structure (e.g., any annuloplasty
20 structure comprising mount system 900) to the annulus of the patient. Channel 460 has a diameter between about 0.8 mm and 2.5 mm, e.g., 1.8 mm, that is sized to facilitate passage therethrough of any one of the anchors, anchoring structures, or anchoring systems described herein. Typically, the anchors described herein are configured for passage through channel 460 have a diameter of between about 0.5 mm and 2.4 mm, e.g.,
25 1.6 mm.

First portion 464 of lateral wall 467 of mount 461 is shaped to define a tapered opening 950 above channel 460. Opening 950 has a diameter that is typically larger than a diameter D2 of channel 460. Typically, during the anchoring of the annuloplasty structure to the annulus, an anchor is coupled to an advancement structure, e.g., a tube or a
30 rod, at a distal end thereof and is advanced via the advancement structure toward channel 460. In some embodiments, a portion of the distal end of the advancement structure has a diameter that is slightly larger than the proximal end of channel 460, i.e., opening 950 of anchor mount 461. Thus, the advancement of the advancement structure is restricted from

passage through channel 460 beyond the portion of the distal end of the tube that has a diameter larger than the diameter of channel 460. This restriction helps ensure that the anchor is not advanced too deeply within tissue of the annulus:

5 In some embodiments, a proximal portion (e.g., the portion of the anchor that is coupled to the distal end of the advancement structure) of the anchor is configured to expand. In such an embodiment, the proximal portion of the anchor is compressed within an overtube during the advancement of the anchor toward the annulus of the valve. Once the anchor is positioned properly within channel 460 and is initially anchored to the
10 annulus of the valve, the overtube is slid proximally from the proximal end of the anchor and the proximal portion is allowed to expand. In such an embodiment, the expanded portion of the anchor has a diameter that is (a) larger than diameter D2 of channel 460 and (b) smaller than the diameter at the distal end of opening 950. Thus, the expanded, proximal portion of the anchor rests within the proximal end of opening 950 and functions as a cap which restricts further distal advancement of the anchor into the tissue of the
15 annulus.

Anchor mount 461 is shaped to provide an anchor mount and ratchet body lumen 920 for passage of ratchet body 202 of any of the ratchet mechanisms described herein. Ratchet body lumen 920 has (a) a longitudinal axis 942 that is substantially parallel with respect to the plane of the annulus and parallel with the longitudinal axis of the
20 annuloplasty structure, and (b) an axis 940 that is typically at a non-zero angle, e.g., transverse, with respect to longitudinal axis 942. Channel 460 has a first axis 930 is typically at a non-zero angle, e.g., transverse, with respect to longitudinal axis 942. Typically, lumen 920 is disposed with respect to channel 460 such that axis 940 of lumen 920 is disposed at an angle theta, with respect to axis 930 of channel 460. Typically, the
25 anchor is anchored at angle theta with respect to axes 940 and 920 and the plane of the annulus of the valve. It is to be noted angle theta may range between 10 degrees and 70 degrees, typically 30 degrees.

Typically, for embodiments in which the annuloplasty structure comprises a plurality of anchor mount systems 900, angle theta is identical for all mounts 461.
30 Alternatively, a first portion of the plurality of anchor mount systems 900 has an angle theta that differs from the angle theta of a second portion of the plurality of anchor mount systems 900. For example, a portion of anchor mount systems 900 designated to be anchored to the anterior portion of the annulus has an angle theta that is different from a

portion of anchor mount systems 900 designated to be anchored to the posterior portion of the annulus. Thus, the anchors may be anchored to different portions of the annulus at different angles in response to a need therefor.

In some embodiments, the contracting wire described herein passes through lumen 920 alongside ratchet body 202. In some embodiments, mount 461 of system 900 is shaped to provide an additional distinct lumen configured for passage therethrough of the contracting wire (configuration not shown).

Anchor mount 461 comprises first and second coupling sites 960 and 970 configured for coupling, e.g., wrapping therearound or welding, respective ends of one or more compressible subunits 450 as described hereinabove.

Fig. 9 shows an anchor mount system 1000 comprising an anchor mount 461 having a curved lateral surface 1100 that is coupled to an anchor channel 350 for passage of an anchor therethrough, in accordance with an embodiment of the present invention. Anchor mount 461 is configured for use in combination with any of the annuloplasty structures described herein. Mount 461 and is shaped to define a first lumen 1010 configured for passage therethrough of the contracting wire and a second lumen 1020 for passage therethrough of the ratchet body of any one of the ratchet mechanisms described herein. Lumens 1010 and 1020 facilitate unobstructed passage of the contracting wire and the ratchet body, respectively, with respect to the passage of an anchor through channel 350.

As described hereinabove with respect to Fig. 8, lumen 1020 has a first axis 1022 and channel 350 has a second axis 1030 which is disposed at an angle θ (e.g., between 10 degrees and 70 degrees, typically 30 degrees) with respect to first axis 1022. As such, the anchor passed through channel 350 is anchored to the annulus at angle θ with respect to the ratchet body disposed within lumen 1020.

Anchor mount 461 comprises first and second coupling sites 1110 and 1112 configured for coupling, e.g., wrapping therearound or welding, respective ends of one or more compressible subunits 450 as described hereinabove.

Fig. 10 shows an anchor mount system 1111 comprising an anchor mount 461 comprising lateral-aperture anchor mount 341 which is shaped to define an aperture 340 configured for passage therethrough of an anchor, as described hereinabove with reference to Fig. 3, in accordance with an embodiment of the present invention. In some

embodiments, the anchor is slid through aperture 340 and rests against portions 1142 of mount 461 which define aperture 340. Typically, portions 1142 provide horizontal surfaces 1140 which function as shelves impeding continued distal motion of an anchor configured to be advanced through aperture 340. In some embodiment, a channel for passage of the anchor is welded to mount 461 along portions 1142 of mount 461. In some 5 embodiments, the channel is advanced toward mount 461 together with the anchor. In such an embodiment, the channel is free to rotate with respect to aperture 340 along the longitudinal axis of mount 461.

Anchor mount 461 comprises a substantially tubular element 463 which defines a 10 longitudinal anchor mount lumen. Aperture 340 is created at a location of mount 461 such that passage of an anchor via aperture 340, directly or indirectly, does not interfere with the contracting wire and/or ratchet body disposed within the longitudinal lumen of mount 461.

Reference is now made to Figs. 5C and 10. Anchor mount 461 also functions as a 15 housing for fixed end 210 of ratchet body 202. Anchor mount 461 is shaped to define slit 520 which engages and locks portion 212 of fixed end 210.

Anchor mount 461 comprises first and second coupling sites 112 and 114 configured for coupling, e.g., wrapping therearound or welding, respective ends of one or more compressible subunits 450.

Reference is now made to Fig. 11, which is a schematic illustration an anchor 20 tube-channel 1200 configured to be used in combination with any one of anchor mounts 461 described herein, in accordance with an embodiment of the present invention. In some embodiments, anchor channel 1200 is configured to be advanced through lumen 501 of anchor mount 461 shown in Figs. 5A and 5C. In some embodiments, channel 1200 is 25 welded to anchor mount 461, shown in Figs. 3, 4, and 10, via aperture 340. In some embodiments, during the manufacture of mount 461, channel 1200 is welded via surface 1100 to anchor mount 461, shown in Fig. 9, in place of channel 350.

Channel 1200 has (a) a proximal end 1250 which provides a passageway for passage of an anchor through a channel 1210 of channel 1200, and (b) a distal end 1260 30 which typically rests against the annulus of the valve when the annuloplasty structure is positioned along the annulus. Proximal end 1250 of channel 1200 is shaped to define an external ring 1220 having a diameter larger than the diameter of proximal end 1250 of

channel 1200. For embodiments in which channel 1200 is configured to be advanced distally through lumen 501 of anchor mount 461 shown in Figs. 5A and 5C, ring 1220 functions to impede continued distal motion of channel 1200 beyond a predetermined depth, as limited by ring 1220 abutting a proximal opening of channel 501 of anchor mount 461. In such an embodiment, channel 1200 is free to rotate with respect to aperture 340 along the longitudinal axis of mount 461.

Channel 1200 is shaped to define one or more (e.g., two, as shown) lateral slits 1230 and 1240. In some embodiments, a longitudinal bar (not shown) is configured to be welded between slits 1230 and 1240. Slits 1230 and 1240 enable the bar to be welded to channel 1200 in any given configuration, e.g., substantially perpendicularly to or diagonally with respect to slits 1230 and 1240, and at any angle with respect to slits 1230 and 1240. For embodiments in which the bar is welded diagonally with respect to slits 1230 and 1240, a first end of the bar may be coupled to a portion of channel 1200 defining proximal end 1231 of slit 1230 while a second end of the bar is coupled to a portion of channel 1200 defining distal end 1242 of slit 1240, by way of illustration and not limitation. For example, in some embodiments, the first end of the bar may be coupled to proximal end 1231 of slit 1230 while the second end of the bar is coupled to a portion defining slit 1240 that is between proximal end 1241 and distal end 1242 thereof. For embodiments in which the bar is welded substantially perpendicularly with respect to slits 1230 and 1240, the first and second ends of the bar may be coupled to: (1) proximal end 1231 of slit 1230 and proximal end 1241 of slit 1240, respectively, (2) distal end 1232 of slit 1230 and distal end 1242 of slit 1240, respectively, or (3) parallel portions of slits 1230 and 1240 that are between the respective distal and proximal ends of slits 1230 and 1240.

Typically, the bar provides a reference force to help corkscrew the anchor into tissue of the annulus during the initial corkscrewing thereof. Even when the bar restricts further distal motion of the anchor beyond a predetermined distance (e.g., a predetermined distance from that lateral surface of mount 461 which rests against tissue of the annulus), the anchor is allowed to resume rotational motion together with rotational motion of channel 1200 for embodiments in which channel 1200 is not welded to anchor mount 461. In the event that a gap is created between the annulus tissue and the annuloplasty structure during the initial anchoring of the structure to the annulus of the valve, this continued rotational motion draws tissue of the annulus toward the annuloplasty structure. Such

proximal drawing of the tissue thereby minimizes and substantially eliminates the gap. Techniques for use with a helical anchor and the bar as described herein may be used in combination with techniques described in US Provisional Application 61/001,013 to Gross et al., entitled, "Segmented ring placement," filed October 29, 2007, which is
5 incorporated herein by reference.

Fig. 12 is a schematic illustration of an anchoring structure 1800 comprising a tapered, conical helical element 1802 comprising a plurality of coils 1810, in accordance with an embodiment of the present invention. Typically, the plurality of coils 1810 comprises a pointed distal end 1820 which punctures tissue of the annulus and allows for
10 coils 1810 to be corkscrewed distally into the tissue of the annulus. A proximal surface of element 1802 is coupled to a head portion 1830 comprising raised surfaces 1832 having a defined conformation. In some embodiments, head portion 1830 functions to prevent distal screwing of structure 1800 into the annulus of the patient beyond a predetermined depth as defined by the combined length of head portion 1830 and coils 1810. Although
15 structure 1800 is not able to be advanced further distally, continued rotation of structure 1800 draws tissue proximally with respect to the annuloplasty structure, thereby substantially minimizing or eliminating a gap that may be created between the annuloplasty structure and the tissue of the annulus.

Typically, an anchor advancement structure, e.g., a tube or a rod, (not shown) is
20 coupled at a distal end thereof to structure 1800 via raised surfaces 1832. In such an embodiment, the distal end of the advancement device is shaped to define recessed portions which are similar in shape to the define conformation of raised surfaces 1832. The advancement device is coupled to structure 1800 when the recessed portions of the device accommodate the conformation of raised surfaces 1832 by surrounding and
25 locking in place surfaces 1832 with respect to the recessed portions of the advancement device. The advancement device is locked together with structure 1800 when a rotational force is applied to the advancement force in a rotational direction as indicated by the arrow. Once the advancement device facilitates the anchoring of structure 1800 to the annulus of the patient, a rotational force is applied to the anchor advancement structure in
30 a direction opposite to the direction indicated by the arrow which detaches the advancement device from structure 1800 by sliding the recessed portions of the advancement device away from raised structures 1832.

For embodiments in which structure 1800 is used to percutaneously anchor an annuloplasty structure to the annulus, the anchor advancement structure comprises an advancement structure, e.g., a tube or a rod, which is typically coupled to head portion 1830 prior to being transcatheterally advanced toward the annuloplasty structure. For
5
embodiments in which anchor structure 1800 is used to anchor the annuloplasty structure to the annulus during an open-heart procedure, an external anchoring device (e.g., an advancement tube, an advancement rod, or a screw-driving system) is used in order to facilitate anchoring of structure 1800 to the annulus.

In either embodiment, once the anchor advancement structure advances the anchor
10
toward the annuloplasty structure, the anchor advancement structure is rotated in order to facilitate corkscrewing of anchoring structure 1800 into the annulus of the patient. For embodiments in which the compressible subunits of the annuloplasty structure comprise a braided mesh, as described hereinabove, structure 1800 may be advanced through the mesh and anchor the annuloplasty structure to the annulus via the mesh. For
15
embodiments in which the compressible subunits of the annuloplasty structure comprise a coiled structure, coils 1810 of structure 1800 are coiled around a portion of coils of the coiled compressible subunits of the annuloplasty structure and subsequently through the tissue of the annulus of the patient. During the coiling of coils 1810 of structure 1800 around the portion of coils of the coiled compressible subunits of the annuloplasty
20
structure, a longitudinal axis 1801 of structure 1800 is at a non-zero angle, e.g., perpendicular, with respect to a longitudinal axis of the annuloplasty structure. Such intercoiling of coils 1810 with the coils of the coiled compressible subunits of the annuloplasty structure facilitates the coupling of the annuloplasty structure with anchoring structure 1800 during the corkscrewing of structure 1800 into the tissue of the annulus.

25
For embodiments in which the annuloplasty structure comprises at least one anchor mount, as described hereinabove, structure 1800 is advanced through the anchor mount and into the annulus of the patient.

Reference is now made to Figs. 5A, 5C, and 12. Typically, head portion 1830 has a diameter that is larger than the inner diameter of lumen 501 of anchor mount 461. As
30
anchoring structure 1800 is advanced through lumen 501, a distal surface of head portion 1830 abuts a proximal opening of lumen 501 and inhibits continued distal motion of structure 1800 through the tissue of the annulus beyond the predetermined depth.

Reference is now made to Figs. 8 and 12. Typically, the diameter of head portion 1830 is larger than diameter D2 of channel 460 defined by anchor mount 461. As structure 1800 is advanced through channel 460, the distal surface of head portion 1830 abuts proximal opening 950 and inhibits continued distal motion of structure 1800 through the tissue of the annulus beyond the predetermined depth.

Reference is now made to Figs. 9 and 12. Typically, the diameter of head portion 1830 is larger than the inner diameter of channel 350 coupled to anchor mount 461. As structure 1800 is advanced through channel 350, the distal surface of head portion 1830 abuts a proximal opening of channel 350 and inhibits continued distal motion of coils 1810 through the tissue of the annulus beyond the predetermined distance.

Reference is now made to Figs. 10 and 12. As structure 1800 is advanced through channel 350, the distal surface of head portion 1830 abuts horizontal surfaces 1140 defining aperture 340 and inhibits continued distal motion of coils 1810 through the tissue of the annulus beyond the predetermined distance.

Reference is now made to Figs. 11 and 12. As structure 1800 is advanced through channel 1210 of channel 1200, the distal surface of head portion 1830 abuts proximal end 1250 of channel 1200 and inhibits continued distal motion of coils 1810 through the tissue of the annulus.

Reference is again made to Fig. 12. The proximal coil of helical element 1802 has a diameter that is larger than the diameter of the distal coil of element 1802. The diameters of the coils of helical element 1802 are gradually reduced in each successive coil from the proximal coil to the distal coil. The distal coil is corkscrewed into the tissue of the annulus following the puncturing of the annulus by pointed distal end 1820. As the distal coil is corkscrewed distally through the tissue of the annulus, the distal coil pushes against the surrounding tissue, thereby exerting a radial force against surrounding tissue of the annulus. Each successive proximal coil of helical element 1802 enters an opening defined by the distal coil adjacent thereto. The diameter of the opening is smaller than the diameter of the successive proximal coil. Thus, each successive proximal coil exerts an outward, radial force on surrounding tissue corresponding to the diameter of successive proximal coil. Thus, the proximal coil exerts a greater force on the surrounding tissue than does the distal coil. It is to be noted that the ratio between the diameter of the

proximal coil to the diameter of the distal coil is shown by way of illustration and not limitation. For example, the ratio may be smaller than the ratio that appears in Fig. 12.

In some embodiments, the proximal coil of helical element 1802 has a diameter that is smaller than the diameter of the distal coil of element 1802 (configuration not shown). The diameters of the coils of helical element 1802 are gradually increased in each successive coil from the proximal coil to the distal coil. The distal coil is corkscrewed into the tissue of the annulus following the puncturing of the annulus by pointed distal end 1820. As the distal coil is corkscrewed distally through the tissue of the annulus, the distal coil pushes against the surrounding tissue, thereby exerting a radial force against surrounding tissue of the annulus. Each successive proximal coil of the helical element enters an opening defined by the distal coil adjacent thereto. Thus, the frictional force of the cardiac tissue on the anchor is reduced. The diameter of the opening is larger than the diameter of the successive proximal coil. Thus, each successive proximal coil exerts an inward, radial force on tissue disposed within the lumen of the successive proximal coil corresponding to the diameter of the successive coil. Thus, the proximal coil exerts a greater force tissue disposed within the lumen defined by helical element 1802 than does the distal coil. Additionally, each coil of helical element 1802 exerts an inward, radial force on tissue disposed within a lumen of helical element 1802 corresponding to the diameter of each respective coil.

Figs. 13A-B show an anchor 1900 comprising a distal barb 1930 and body portion 1910 which assume first and second configurations, respectively, in accordance with an embodiment of the present invention. Anchor 1900 has a proximal end 1920 and a distal pointed tip 1940 that punctures tissue of the patient. Body portion 1910 is shaped to define a narrow distal portion 1950 which is proximal to distal barb 1930. Typically, anchor 1900 comprises a shape-memory alloy, e.g., nitinol, which enables structure to transition between the configuration shown in Fig. 13A to the configuration shown in Fig. 13B.

During advancement toward the cardiac tissue, anchor 1900 is typically surrounded by an overtube (not shown) which maintains anchor 1900 in a generally straight configuration (shown in Fig. 13A). A distal end of the overtube contacts tissue of the patient and anchor 1900 is slightly pushed distally so that barb 1930 emerges from within the tube and is able to puncture the tissue. Anchor 1900 is further pushed distally from within the overtube such that anchor 1900 further penetrates the tissue and is

allowed to gradually assume its resting configuration (i.e., the configuration anchor 1900 has a tendency to assume, as shown in Fig. 13B) commensurate with the extent of distal pushing of anchor 1900.

For embodiments in which anchor 1900 is used to anchor the annuloplasty structure comprising the braided mesh described hereinabove, anchor 1900 is initially
5 passed through the mesh prior to being advanced through the tissue of the patient. In such an embodiment, prior to anchoring the annuloplasty structure to the annulus of the patient, anchor 1900 anchors itself to the annuloplasty structure by being entwined by the mesh. In some embodiments, prior to being advanced through tissues of the annulus, anchor
10 1900 is advanced through, and in some embodiments, coupled to, anchor mounts 461 described herein.

In some embodiments, as anchor 1900 assumes its bent configuration (shown in Fig. 13B), the proximal bending of body 1910 pushes proximally tissue of the annulus that is disposed between anchor 1900 and the annuloplasty structure positioned at the
15 surface of the annulus. Thus, annulus tissue is pushed proximally toward the annuloplasty structure. For instances in which a gap is created between the annuloplasty structure and the tissue of the annulus, the proximal pushing of the annulus tissue toward the annuloplasty structure in response to the bending of anchor 1900, substantially minimizes or eliminates the gap.

20 Figs. 13C-D show anchor 1900 as described hereinabove with reference to Figs 13A-B with the exception that body 1910 is not shaped to provide narrow distal portion 1950, in accordance with an embodiment of the present invention.

Fig. 13E is a cross-sectional illustration of anchor 1900 anchored within tissue 1960, in accordance with an embodiment of the present invention. For embodiments in
25 which anchor 1900 is used in combination with an annuloplasty structure, the annuloplasty structure is positioned at a surface 1962 of tissue 1960. In such an embodiment, proximal end 1920 is coupled to (e.g., disposed within) the annuloplasty structure at a first location thereof, body portion 1910 of anchor 1900 is disposed within tissue 1960 in a "U"-shaped configuration thereof, and distal barb 1930 is exposed from
30 within tissue 1960 and is coupled to the annuloplasty structure at a second location thereof.

For embodiments in which the annuloplasty structure comprises the braided mesh, barb 1930 is first passed through the braided mesh at the first location of the annuloplasty structure, through tissue 1960, then through the braided mesh at the second location of the annuloplasty structure, thereby anchoring the structure to the annulus while additionally
5 coupling anchor 1900 to the annuloplasty structure.

Figs. 14A-B which are schematic illustrations of an anchor 2000 having a substantially rigid body portion 2010, a distal pointed tip 2032, and a flap 2050 proximal to distal tip 2032 which assume first and second positions, respectively, in accordance with an embodiment of the present invention. Body portion 2010 has a proximal end
10 2020 and is shaped to define a slit 2040 between a distal portion of body 2010 and flap 2050. Slit 2040 enables flap 2050 to transition between the configuration of flap 2050 shown in Fig. 14A to the configuration of flap 2050 shown in Fig. 14B. Typically, anchor 2000 comprises a shape-memory alloy, e.g., nitinol, which enables flap 2050 to transition along a junction 2030 between flap 2050 and body portion 2010 between the
15 configuration shown in Fig. 14A to its resting configuration (i.e., the configuration flap has a tendency to assume, as shown in Fig. 14B).

Anchor 2000 is typically surrounded by a sheath or sleeve (not shown) that is typically rectangular and defines a lumen for surrounding anchor 2000, and enables flap 2050 to maintain a generally straight configuration (shown in Fig. 14A) as it is advanced
20 toward the tissue of the patient. A distal end of the sheath contacts tissue of the patient and anchor 2000 is slightly pushed distally so that distal pointed end 2032 emerges from within the tube and is able to puncture the tissue. Anchor 2000 is further pushed distally from within the overtube such that anchor 2000 further penetrates the tissue. Structure is then distally advanced to a desired depth and is then pulled proximally enabling flap 2050
25 to gradually bend along junction 2030 away from a longitudinal axis of body portion 2010. Anchor 2000 assumes its relaxed, or bent, position (shown in Fig. 14B) commensurate with the extent of proximal pulling of anchor 2000. A proximal end of flap 2050 is shaped to define a pointed tip 2052. As flap 2050 assumes its relaxed, or bent, configuration, tip 2052 punctures surrounding tissue in order to further anchor
30 anchor 2000 to tissue of the patient. In its relaxed, or bent, configuration, flap 2050 defines a surface 2051 that is aligned angularly with respect to the longitudinal axis of body portion 2010. Surface 2051 defined by flap 2050 is configured to restrict further proximal motion of anchor 2000.

For embodiments in which anchor 2000 is used to anchor the annuloplasty structure comprising the braided mesh described hereinabove, the sheath or sleeve surrounding anchor 2000 is initially passed through the mesh. In some embodiments, prior to being advanced through tissues of the annulus, anchor 2000 is advanced through, and in some embodiments, coupled to, anchor mounts 461 described herein. For
5
embodiments in which anchor 2000 is advanced through anchor mounts 461, the channel provided by the anchor mount functions to maintain the generally straightened configuration as structure is advanced through the anchor mount toward the tissue of the annulus.

10 Fig. 15 shows an anchor 2100 having a proximal end 2120, a substantially rigid, cylindrical body portion 2110, and a distal end 2130 shaped to define distal prongs 2140 each having pointed distal end 2142, in accordance with an embodiment of the present invention. Each prong 2140 is shaped to define a tapered body portion and a distal barb 2150 shaped to define distal pointed end 2142 and proximal pointed ends 2152.
15 Typically, anchor 2100 comprises a shape-memory alloy, e.g., nitinol, which enables prongs 2140 to transition from the substantially straight configuration, as shown, to a curved configuration in which pointed distal ends 2142 curve proximally such each prong 2140 assumes a substantially "U"-shaped configuration. It is to be noted that anchor 2100 is shown as comprising three prongs 2140 by way of illustration and not limitation, and
20 that any suitable number or prongs may be used.

During advancement toward the cardiac tissue, anchor 2100 is typically surrounded by an overtube (not shown) which maintains prongs 2140 in a generally straight configuration (as shown). A distal end of the overtube contacts tissue of the patient and anchor 2100 is slightly pushed distally so that distal pointed ends 2142 emerge
25 from within the tube and puncture the tissue. Anchor 2100 is further pushed distally from within the overtube such that anchor 2100 further penetrates the tissue and prongs 2140 are allowed to gradually bend away from a longitudinal axis of body portion 2110 in order to assume their respective bent configurations (shown in Fig. 16B) commensurate with the extent of distal pushing of anchor 2100. As prongs 2140 assume their respective bent
30 configurations, proximal pointed ends 2152 puncture surrounding tissue in order to further anchor anchor 2100 to tissue of the patient. In its expanded, bent configuration, anchor 2100 is configured to restrict proximal motion of anchor 2100 through the tissue.

For embodiments in which anchor 2100 is used to anchor the annuloplasty structure comprising the braided mesh described hereinabove, the overtube is initially passed through the mesh until it contacts cardiac tissue underlying the annuloplasty structure. In such an embodiment, prior to anchoring the annuloplasty structure to the annulus of the patient anchor 2100 is anchored to the annuloplasty structure by being entwined in the braided mesh. Once the distal end of the overtube contacts tissue of the annulus, anchor 2100 is pushed distally from within the overtube and into tissue of the annulus. In some embodiments, prior to being advanced through tissues of the annulus, anchor 2100 is advanced through, and in some embodiments, coupled to, anchor mounts 461 described herein.

For embodiments in which anchor 2100 is advanced through anchor mounts 461 described herein, the channel provided by the anchor mount functions to maintain the generally straightened configuration as anchor 2100 is advanced through the anchor mount toward the tissue of the annulus.

In some embodiments, as prongs 2140 of anchor 2100 assume their respective bent configurations (shown in Fig. 16B), the proximal bending of prongs 2140 pushes proximally tissue of the annulus that is disposed between anchor 2100 and the annuloplasty structure. Thus, annulus tissue is pushed proximally toward the annuloplasty structure. For instances in which a gap is created between the annuloplasty structure and the tissue of the annulus, the proximal pushing of the annulus tissue toward the annuloplasty structure in response to the bending of prongs 2140 of anchor 2100, substantially minimizes or eliminates the gap.

Anchor 2100 is shaped to define an opening 2160 in a vicinity of proximal end 2120 of anchor 2100. Typically, an anchoring advancement device, an advancement tube, and advancement rod, or a suture, is removably coupled to anchor 2100 by being looped through opening 2160.

It is to be noted that anchor 2100 is shaped to define opening 2160 by way of illustration and not limitation. For example, anchor 2100 may be manufactured without opening 2160. For either embodiment in which anchor 2100 is shaped to define opening 2160 or in which anchor 2100 is not shaped to define opening 2160, an anchor advancement structure, as described herein, may be coupled to anchor 2100 via a lumen defined by cylindrical body portion 2110 of anchor 2100.

Figs. 16A-B show an anchor delivery system 2200 comprising stationary finger-engaging rings 2220, a displaceable finger-engaging ring 2222, and a tubular housing 2210 configured to advance and facilitate anchoring of anchor 2100, in accordance with an embodiment of the present invention. System 2200 comprises a pushing rod 2224
5 which is coupled at a distal end thereof to displaceable finger-engaging ring 2222 and is slidably displaced through tubular housing 2210. A distal end of pushing rod 2224 is coupled to a proximal end of a secondary pushing rod 2226 which is configured to slide within a lumen defined by a distal tubular element 2228.

Typically, one or more anchors 2100 are preloaded within distal tubular element
10 2228. In response to distal displacement of ring 2222, pushing rod 2224 applies a force to secondary pushing rod 2226, which in turn slides in part within element 2228 and applies a force to the at least one anchor 2100 disposed therein. In response to the applied force, anchor 2100 is pushed from within element 2228, and ultimately distally to a distal end 2230 of element 2228. As it is pushed, anchor 2100 is advanced into tissue of the patient,
15 as described hereinabove with reference to Fig. 15.

In some embodiments, distal tubular element 2228 may be attachable to rod 2226 by being slidable around a distal portion of rod 2226. In such an embodiment, one or more anchors are preloaded within tubular element 2228 and subsequently, element 2228 is slid around the distal portion of rod 2226.

As shown in Fig. 16A, anchor 2100 is preloaded within tubular element 2228 of
20 system 2200 in a compressed state thereof. A proximal end of anchor 2100 is coupled to a cap 2170 comprising at least one expandable projection 2172 which is compressed within tube 2228. When anchor 2100 is expanded (shown in Fig. 16B), projections 2172 impede continued distal advancement of anchor 2100 within tissue of the patient beyond a
25 predetermined depth that is defined by the combined height of anchor 2100 and a portion of cap 2170 between a distal end thereof and a distal end of projection 2172 in an expanded state thereof.

Fig. 16B shows ring 2222 pushed distally, as indicated by the arrow. A length of an exposed portion of secondary pushing rod 2226 is shorter than the length of the
30 exposed portion of rod 2226, as shown in Fig. 16A, indicating that a distal portion of rod 2226 has been pushed within tubular element 2228, which thereby pushes anchor 2100 distally from within tubular element 2228. Once exposed from within element 2228,

anchor 2100 is allowed to assume its relaxed, predetermined configuration, as shown in Fig. 16B, in which prongs 2140 are allowed to curl proximally, as described hereinabove with reference to Fig. 15. Additionally, projections 2172 are allowed to assume their respective relaxed configurations, in which projections 2172 project laterally from cap
5 2170.

In some embodiments, in response to continued pushing of ring 2222, a distal portion of ring 2222 abuts a proximal portion of tubular housing 2210 and impedes continued distal motion of rod 2226.

Typically, system 2200 is used during an open-heart procedure in order to anchor
10 an annuloplasty device to the annulus of the patient. For embodiments in which the annuloplasty structure comprises a braided mesh as described herein, distal end 2230 of system 2200 is advanced through the braided mesh until it abuts against the lateral surface of the annuloplasty structure, i.e., the surface with is in contact with the annulus. Distal displacement of ring 2222 advances the at least one anchor 2100 distally to distal end
15 2230 of system 2200, through a portion of the braided mesh, and subsequently into tissue of the patient. Anchor 2100 is coupled to the braided mesh when projections 2172 engage, e.g., are entangled with, at least a portion of the mesh.

For embodiments in which the annuloplasty structure comprises at least one anchor mount, as described herein, distal end 2230 of system 2200 may be advanced at
20 least in part through the anchor mount. Ring 2222 is distally displaced and anchor 2100 is advanced distally to distal end 2230 of system 2200 through the channel of the anchor mount, and subsequently into tissue of the patient. As the anchor is advanced through the channel of the mount, the wall defining the channel maintains the straight configuration of the anchor. As cap 2170 is advanced distally, and projections 2172 emerge from within
25 tubular element 2228, projections 2172 expand. Typically, a diameter defined by expanded projections 2172 is larger than the diameter of the channel of the anchor mount. As such, the distal ends of projections 2172 abut against the proximal opening of the channel and impede continued distal advancement of the anchor through the tissue of the patient.

30 For embodiments in which a plurality of anchors are housed within tubular element 2228, system 2200 comprises a baffle mechanism or a ratchet mechanism in

order to ensure that distal displacement of ring 2222 will advance only one anchor at a time out of tubular element 2228.

It is to be noted that the scope of the present invention includes use of system 2200 for advancement and anchoring of any of the anchors or anchoring structures described herein. For embodiments in which system 2200 is used in order to anchor the helical anchors described herein, system 2200 may be rotated along a longitudinal axis of housing 2210.

Reference is now made to Figs. 17A-F, which are schematic illustrations of a system 400 for repairing a mitral valve 30, being advanced into a left atrium of a patient, in accordance with an embodiment of the present invention. Typically, a catheter 404 (Fig. 17B) is advanced into the left atrium of the patient using a percutaneous endovascular approach typically combined with monitoring by electromagnetic and/or sound waves, e.g., fluoroscopy, transesophageal echo, transthoracic echo, and/or echocardiography, to maintain real-time orientation of a distal tip of the catheter within the heart of the patient. Typically, catheter 404 is transeptally advanced into the left atrium.

Catheter 404 typically comprises a 13 F catheter, although another size may be appropriate for a given patient. In some embodiments, catheter 404 is advanced through vasculature of the patient and into the right atrium using a suitable point of origin typically determined for a given patient. For example:

(1) Catheter 404 is introduced into the femoral vein of the patient, through the inferior vena cava, into the right atrium of the heart, transeptally, e.g., typically, through the fossa ovalis, and finally into the left atrium;

(2) Catheter 404 is introduced into the basilic vein, through the subclavian vein to the superior vena cava, into the right atrium, transeptally, e.g., typically, through the fossa ovalis, and finally into the left atrium; or

(3) Catheter 404 is introduced into the external jugular vein, through the subclavian vein to the superior vena cava, into the right atrium, transeptally, e.g., typically, through the fossa ovalis, and finally into the left atrium.

In some embodiments; catheter 404 is advanced through an inferior vena cava of the patient (as shown) and into the right atrium using a suitable point of origin typically determined for a given patient.

Fig. 17A shows a guide wire 402 being advanced into the right atrium of the patient. Advancement of wire 402 typically precedes advancement of catheter 404 into the right atrium of the patient. Wire 402 comprises a semi-rigid wire which provides a guide for the subsequent advancement of catheter 404 therealong and into the right atrium of the patient, as shown in Fig. 17B. Once catheter 404 has entered the right atrium, guide wire 402 is retracted and extracted from within the body of the patient (Fig. 17C). In Fig. 17D, catheter 404 is pushed distally until it reaches the interatrial septum of heart 20 of the patient.

(In this context, in the specification and in the claims, "proximal" means closer to the orifice through which catheter 404 is originally placed into the vasculature of the patient, and "distal" means further from this orifice.)

As shown in Fig. 17E, a resilient needle 406 and a dilator (not shown) are advanced through catheter 404 and into heart 20 of the patient. In order to advance catheter 404 transseptally into the left atrium, the dilator is advanced to the septum, and the needle 406 is pushed from within the dilator and is allowed to puncture the septum of heart 20 such that an opening is created which facilitates passage of the dilator and subsequently catheter 404 therethrough and into the left atrium. Subsequently, the dilator is through the hole in the septum of heart 20 created by needle 406. Typically, the dilator is shaped to define a hollow shaft for passage along needle 406, the hollow shaft being shaped to define a tapered distal end. This tapered distal end is first advanced through the hole created by needle 406. The hole is enlarged when the gradually increasing diameter of the distal end of the dilator is pushed through the hole in the septum. The advancement of catheter 404 through the septum and into the left atrium is followed by the extraction of the dilator and needle 406 from within catheter 404 (Fig. 17F).

Fig. 17G is a schematic illustration of a first discrete segment 430 and a second discrete segment 440 of an annuloplasty structure 408, e.g., at least one elongate segment, typically two as shown, being advanced along catheter 404, in accordance with an embodiment of the present invention. Segments 430 and 440 are disposed within catheter 404 in a substantially linear configuration, thereby having a longitudinal axis thereof. Segments 430 and 440 are configured to be chronically implanted within heart 20 along an annulus 40 of mitral valve 30. Typically, segments 430 and 440 comprise a biocompatible material, e.g., ePTFE, PTFE, nitinol, stainless steel, platinum iridium, titanium, or cobalt chrome. In some embodiments, segments 430 and 440 are coated with

PTFE (Polytetrafluoroethylene). Compressible subunits 450 are illustrated as coils, by way of illustration and not limitation, and facilitate bending of the segments into a suitable configuration and compressing of the segments when they are later drawn toward one another. For example, compressible subunits 450 may be shaped as struts of a stent, as a bellows, or as an accordion, or may comprise a braided mesh (as shown in Fig. 1). In some embodiments, a braided mesh comprising an elastic material, e.g., metal or fabric such as polyester, surrounds segments 430 and 440.

In some embodiments of the present invention, segments 430 and 440 comprise coils made of stainless steel, e.g., type 316 LVM. Suitable coil shapes include round wire coils or flat wire coils.

It is to be noted that any one of ratchet mechanisms (e.g., ratchet mechanism 200, ratchet mechanism 600, or tubular ratchet mechanism 3101) described herein may be disposed within the longitudinal lumen of structure 408.

Prior to advancing segments 430 and 440 into the left atrium of the patient, segments 430 and 440 are loaded into an advancement catheter 410 in a substantially linear configuration, as shown in Fig. 17G. The linear configuration defines a longitudinal axis of segments 430 and 440 of structure 408. Segments 430 and 440 are typically advanced into the left atrium of the patient during a single transcatheter advancement.

During advancement of segment 430 within advancement catheter 410, segment 430 has a length L1 between about 20 mm and about 60 mm, e.g., 30 mm. Typically, segment 430 is configured for positioning along a portion of annulus 40 at the junction between annulus 40 and the base of the anteromedial leaflet of valve 30. Similarly, second segment 440 is designated to be anchored to annulus 40 at the base of the posterolateral leaflet, and thus is sized in accordance therewith. For example, segment 440 may have a length L2 of between about 30 mm and about 100 mm, e.g., 50 mm. The respective lengths of segments 430 and 440 enable the segments to dynamically support the mitral valve in accordance with the relative motion of the anteromedial and posterolateral leaflets. Typically, segments 430 and 440 each have a diameter L3 of between about 2.0 mm and about 4.0 mm, typically between about 2.5 mm and about 3.5 mm.

Typically, segments 430 and 440 are each shaped to define a lateral wall that has at least one flexible hollow lumen configured for sliding advancement of at least one control wire therethrough. As shown, a first control wire 480 and a second control wire 490 are disposed within both the first and second segments 430 and 440. Typically, wires 480 and 490 function to position and adjust a relative disposition and configuration of segments 430 and 440 with respect to a configuration of annulus 40 of valve 30. Such functions of wires 480 and 490 are described hereinbelow. As such, a diameter of control wires 480 and 490 (e.g., between about 0.2 mm and about 0.4 mm, typically, between 0.25 mm and 0.3 mm) provides the wires with the strength to control structure 408. Typically, control wires 480 and 490 provide a pulling and/or pushing force to segments 430 and 440.

Control wires 480 and 490 comprise a flexible, resilient, and superelastic material, e.g., nitinol, polyester, ePTFE, stainless steel, or cobalt chrome, and are configured to reside chronically within structure 100. In some embodiments, control wires 480 and 490 comprise a braided polyester suture (e.g., Ticon). In some embodiments, control wires 480 and 490 are coated with polytetrafluoroethylene (PTFE). In some embodiments, control wires 480 and 490 each comprise a plurality of wires that are intertwined to form a rope structure.

In some embodiments, first and second control tubes are disposed within both the first and second segments. Typically, the first and second control tubes are configured to function similarly to control wires 480 and 490 described herein.

Typically, each segment 430 and 440 comprises a plurality of compressible subunits 450 and a plurality of anchor mounts 461 which are disposed alternately with respect to one another. It is to be noted, however, that segments 430 and 440 may each comprise a single elongate structure comprising compressible material and do not comprise anchor mounts 461.

Typically, each anchor mount 461 is shaped to define a lateral wall that is shaped to provide a first portion 464 and a second portion 466 generally at opposite sites of mount 461 when viewed in cross-section (e.g., at 12 o'clock and 6 o'clock). Anchor mounts 461 of annuloplasty structure 408 each comprise at least one channel 460. Channel 460 is configured to extend from first portion 464, through the given segment, to second portion 466. A respective flexible and longitudinal guide member 470 is coupled,

e.g., welded, looped through, or soldered, at a distal end thereof to a portion of lateral wall 462 of mount 461 and is used to facilitate anchoring of annuloplasty structure 408 to the annulus of the patient, as will be described hereinbelow.

5 It is to be noted that although anchor mount 461 is shaped to define channel 460 by way of illustration and not limitation. For example, anchor mount 461 may comprise any one of the anchor mounts described herein with reference to Figs. 1, 3, 4, 5A, 5C, 8, 9, and 10. It is to be noted that a respective anchor channel 1200 described in Fig. 11 may be used in combination with one or more anchor mounts 461.

10 Typically, guide member 470 is configured to facilitate guiding of an anchoring system toward channel 460 (as will be described hereinbelow). Typically, guide member 470 comprises a flexible, superelastic metal wire, e.g., nitinol or PTFE. In some embodiments, guide member 470 comprises a fiber, e.g., nylon, polypropylene, Kevlar, Teflon, or polyester. Typically, each guide member 470 has a diameter of between about 0.05 mm and about 0.3 mm, e.g., 0.1 mm. Prior to advancing segments 430 and 440 into
15 the left atrium of the patient, advancement catheter 410 is preloaded with segments 430 and 440, with control wires 480 and 490, with guide members 470, and with a multilumen catheter 420 which is disposed proximally to segments 430 and 440. Thus, segments 430 and 440 are simultaneously conveyed toward heart 20, during a single transcatheter advancement. Typically, advancement catheter 410 comprises a 12 F catheter, although
20 other sizes may be appropriate depending on the size of catheter 404.

In some embodiments of the present invention, multilumen catheter 420 is shaped to provide a primary lumen and at least one secondary lumen. Typically, multilumen catheter 420 is configured to advance therethrough and into the left atrium an anchor coupled to an anchor-advancement structure, e.g., a tube or a rod. In some embodiments,
25 the multilumen catheter is disposed proximally to the annuloplasty structure and is configured to push the segments through the advancement catheter.

Figs. 17H-I show deployment of first segment 430 of the segmented annuloplasty ring, in accordance with an embodiment of the present invention. Segments 430 and 440 are disposed in a linear configuration within advancement catheter 410 when catheter 410
30 is advanced within catheter 404 and initially enters the left atrium. As shown in Fig. 17H, a distal end of catheter 410 emerges from within catheter 404. Segment 430 maintains its linear configuration as it is initially pushed from within catheter 410.

Anchor mount 461 is coupled to a bar 710, as described hereinabove with reference to Fig. 11. It is to be noted that anchor mount 461 is coupled to bar 710 by way of illustration and not limitation. For example, anchor mount 461 may not be coupled to bar 710, as described hereinabove. Typically, bar 710 is disposed within channel 460 angularly, e.g., substantially perpendicular, with respect to an axis 477 (as shown in Fig. 17G) of channel 460, i.e., the axis that is transverse with respect to the longitudinal axis of structure 408, and substantially parallel to the longitudinal axis of annuloplasty structure 408.

Typically, first and second segments 430 and 440 of structure 408 are ultimately made to assume a somewhat round configuration that resembles an annuloplasty ring in structure and function.

As shown in Fig. 17I, control wires 480 and 490 are tightly pulled proximally, applying a force to segment 430 and compressing segment 430 so that it is made to assume a curved configuration. The curved configuration is thus achieved as compressible subunits 450 are compressed in response to the pulling of control wires 480 and 490. Typically, compressible subunits 450 are compressed generally in parallel with the longitudinal axis of segment 430. Such a curved configuration minimizes the possibility for segment 430 to prematurely contact walls of heart 20: (1) during deployment of system 400 within the left atrium, and (2) prior to positioning segments 430 and 440 along annulus 40.

It is to be noted that in some embodiments, segments 430 and 440 of annuloplasty structure 408 comprise a shape-memory alloy, e.g., nitinol. In some embodiments, segments 430 and 440 are introduced within catheter 410 in a straight configuration, and are each biased to assume a generally semi-circular configuration once expanded from within catheter 410. Annuloplasty structure 408 thus assumes a somewhat round configuration typically independently of the application of a proximal force to control wires 480 and 490. In such an embodiment, control wires 480 and 490 are used instead to expand the segments by separating at least a part of segment 430 from at least a part of segment 440.

Fig. 17J is a schematic illustration of system 400 comprising annuloplasty structure 408 and multilumen catheter 420, in accordance with an embodiment of the present invention. Each control wire 480 and 490 is coupled to a respective adjustment

wire 482 and 492 by way of illustration and not limitation. Adjustment wires 482 and 492 are configured to contribute to adjusting a relative disposition of segments 430 and 440 once inside the left atrium of heart 20. The functions of wires 482 and 492 are described in more detail hereinbelow.

5 Typically, multilumen catheter 420 is shaped to define a primary lumen 426 and secondary lumens 422 and 424. The distal end of each guide member 470 is coupled to a respective anchor mount 461 and the proximal end of each guide member 470 is manipulated or controlled from outside the body of the patient proximally to catheter 410, while a majority of the remaining portion of guide member 470 (i.e., the portion of guide
10 member 470 disposed between the proximal and distal ends thereof) is disposed within primary lumen 426.

In some embodiments, multilumen catheter 420 comprises a plurality of secondary lumens for passage of guide members 470 therethrough. In some embodiments, multilumen catheter 420 provides a respective lumen for each guide member 470. In such
15 an embodiment, catheter 420 prevents tangling of guide members 470 as they are disposed therein. In some embodiments, two or more guide members 470 may be disposed within a single secondary lumen of multilumen catheter 420.

In some embodiments, a handle assembly (not shown) is coupled to a proximal end of catheter 410. The handle assembly may be disposable. Respective proximal ends
20 of guide members 470 are accessible and controllable from the handle assembly. For example, a respective proximal end of each guide member 470 may be coupled to a respective switch which independently controls the guide member. Additionally, respective ends of control wires 480 and 490 are accessible and controllable from the handle assembly. Further additionally, a proximal end of lumen 426 and of catheter 421
25 disposed therein are accessible from the handle assembly in order to advance an anchor through catheter 421 and toward the annuloplasty structure (as will be described hereinbelow).

Each guide member 470 is reversibly coupled to a flexible, steerable catheter 421 which is disposed within primary lumen 426 of multilumen catheter 420. In some
30 embodiments, a distal portion of each guide member 470 is disposed alongside an external surface of at least a portion, e.g., a distal portion, of catheter 421, e.g., typically, when catheter 421 is pushed distally from within multilumen catheter 420. Catheter 421 is

steerable by guide members 470 in response to a pulling force applied to a respective one of guide members 470 (as will be described hereinbelow). Catheter 421 is shaped to define a lumen configured for passage therethrough of an anchor coupled to an anchor advancement system. Catheter 421 is typically steered toward a given anchor mount 461 in response to the pulling of a given guide member 470 attached thereto. Catheter 421 comprises a tapered distal end 429 which is positioned within channel 460 of anchor mount 461. Once end 429 is positioned within channel 460, the anchor disposed within catheter 421 is advanced therefrom distally toward the annulus. Since, a respective anchor or anchoring structure is advanced through the lumen of catheter 421, the lumen of catheter 421 typically has a diameter D_7 of between about 1.0 mm to about 4.0 mm (e.g., 2.0 mm). Diameter D_7 of catheter 421 allows passage therethrough of at least one anchor at a given time.

Typically, once segments 430 and 440 are initially pushed from within catheter 410, and prior to pushing of steerable catheter 421 from within multilumen catheter 420, one or more guide members 470 functions to position and adjust a relative disposition and configuration of segments 430 and 440 with respect to a configuration of annulus 40 of valve 30. For example, pulling on one or more guide members 470 may lift proximally from the annulus a portion of the segment to which it is coupled, while the remaining portions of the segment are disposed in a spatial orientation that is distal with respect to the portion of the segment being raised.

Typically, in order to accommodate for the combined diameters of catheter 421 and the plurality of guide members 470, primary lumen 426 of multilumen catheter 420 has a diameter D_1 of between 1.2 mm and 4.5 mm, e.g., 2.5 mm.

Catheter 421 comprises an external ring 427 disposed proximally to distal end 429 and facilitates coupling of respective distal portions of guide members 470 to the external surface of catheter 421. As shown in the cross-section of ring 427, ring 427 is shaped to define a plurality of lumens 431 for passage therethrough of a respective one of guide members 470. In such an embodiment, guide members 470 are prevented from being tangled together. In some embodiments, two or more guide members 470 pass through a single lumen 431. In such an embodiment, lumen 431 may be circular, oval, or any other suitable shape. It is to be noted that the side and shape of lumen 431 are shown by way of illustration and not limitation and that the size and shape of lumens 431 may be larger than they appear in Fig. 17J. Typically, ring 427 is allowed to rotate with respect to the

longitudinal axis of catheter 421. Such freedom of movement of ring 427 with respect to catheter 421 facilitates unobstructed steering of catheter 421 in response to pulling of a given longitudinal guide member 470. Additionally, the freedom of movement reduces any resistance in pulling of the given guide member 470.

5 First and second portions of control wire 490 and a portion of adjustment wire 482 are disposed within secondary lumen 422 (as shown) of multilumen catheter 420, while first and second portions of control wire 480 and a portion of adjustment wire 492 are disposed within secondary lumen 424 (as shown) of multilumen catheter 420. Multilumen catheter 420 separates and isolates control wire 480 from control wire 490
10 and separates and isolates adjustment wire 482 from adjustment wire 492, thereby enabling the physician to distinguish between each of control wires 480 and 490 and between adjustment wires 482 and 492. Thus, catheter 420 helps facilitate independent control by the physician of each of the wires which ultimately determine the relative positioning of structure 408 within the left atrium of heart 20.

15 In some embodiments, control wires 480 and 490 and adjustment wires 482 and 492 may be disposed within in the same secondary lumen of multilumen catheter 420 and are coupled to the handle (described hereinabove) in such a manner so as to prevent tangling and to allow proper control of each of the wires.

Typically, steerable catheter 421 pushes segments 430 and 440 distally within
20 advancement catheter 410.

Figs. 18A-B are schematic perspective views of system 400 comprising annuloplasty structure 408 which is coupled to annulus 40 of mitral valve 30, in accordance with an embodiment of the present invention. As shown, guide members 470 are coupled at respective distal ends thereof to respective anchor mounts 461 of annuloplasty structure 408. Respective portions of guide members 470 pass through ring
25 427 and alongside catheter 421, and ultimately through advancement catheter 410. As shown, advancement catheter 410 comprises a radiopaque marking 411 at a distal portion thereof, and marking 411 helps the physician locate the distal end of catheter 410 with respect to structure 408. In some embodiments, and during initial positioning of the distal
30 end of advancement catheter 410 within the left atrium of heart 20, at least one steering wire 413, e.g., one as shown, is coupled at a distal end thereof to a distal portion of

catheter 410. A proximal end of steering wire 413 is disposed at a site outside the body of the patient, enabling the physician to steer the distal end of catheter 410.

Control wires 480 and 490 are shown disposed within at least one hollow lumen of both first and second segments 430 and 440 of annuloplasty structure 480, thereby
5 coupling the segments. In some embodiments, each of segments 430 and 440 is shaped to provide a first lumen configured for sliding advancement therethrough of wire 480, and a second lumen configured for sliding advancement of wire 490 (configuration not shown). First and second portions of control wire 480 emerge from within segments 430 and 440 at respective first ends 432 and 442 of segments 430 and 440. The first and second
10 portions of control wire 480 are disposed within secondary lumen 424 of multilumen catheter 420 such that first and second ends of wire 480 are exposed and controllable from outside the body of the patient. Similarly, first and second portions of control wire 490 emerge from within segments 430 and 440 at respective second ends 434 and 444 of segment 430 and 440. The first and second portions of control wire 490 are disposed
15 within secondary lumen 422 of multilumen catheter 420, such that first and second ends of wire 490 are exposed and controllable from outside the body of the patient.

In some embodiments, multilumen catheter 420 is shaped to provide additional secondary lumens (not shown for clarity of illustration). Typically, the additional secondary lumens are provided for passage of supplementary instruments, e.g., for suction
20 and/or irrigation, therethrough and into the left atrium of the patient.

Following the deployment, segments 430 and 440 are expanded by being separated in accordance with the shape of the dilated annulus. In some embodiments, adjustment wires 482 and 492, shown in Fig. 17J, help facilitate the separation of segments 430 and 440. Techniques for use with annuloplasty structure 408 and
25 adjustment wires (referred to hereinabove as 482 and 492) may be used in combination with techniques described in US Provisional Application 61/001,013 to Gross et al., entitled, "Segmented ring placement," filed October 29, 2007.

The separating of segments 430 and 440 occurs when the physician pushes control wires 480 and 490. In some embodiments, during the pushing of control wires
30 480 and 490, the physician simultaneously pushes while pushing the adjustment wires which provide an auxiliary pushing force which helps expand segments 430 and 440. Such pushing of the control wires feeds greater portions of control wires 480 and 490 into

segments 430 and 440. The relaxed configuration of control wires 480 and 490 is shown in Figs. 18A-B. Typically, segments 430 and 440 expand laterally as increasing lengths of control wires 480 and 490 are pushed and fed into segments 430 and 440.

Control wires 480 and 490 enable the physician to independently control a relative
5 disposition of second ends 434 and 444 and first ends 432 and 442 of segments 430 and 440, respectively. For example, distal pushing of the first and second ends of control wire 480 distances second ends 434 and 444 of segments 430 and 440, respectively. Similarly, distal pushing of the first and second ends of control wire 490 distances first ends 432 and 442 of segments 430 and 440, respectively. It is to be noted that the use of two discrete
10 control wires allows for independent control of the distance that separates first ends 432 and 442 and the distance that separates second ends 434 and 444 of segments 430 and 440.

Additionally, pulling on respective ends of control wires 480 and 490 shapes segments 430 and 440 in accordance with the curved structural conformation of annulus
15 40 at a given site destined for anchoring of a respective one of the segments thereto. For example, pulling on a first end of control wire 490 and on a first end of control wire 480 curves segment 430 by drawing together second end 432 and first end 434, respectively, of segment 430. Thus, segment 430 is compressed at least in part, and is made to assume a shape according to the curvature of the annulus at the base of the anteromedial leaflet.

In some embodiments of the present invention, structure 408 is optionally rotated
20 as appropriate about an axis of annulus 40. Guided by fluoroscopy and/or echocardiography, the physician assesses the relative disposition of segments 430 and 440 with respect to annulus 40 of heart 20. Multilumen catheter 420 is configured to be rotatable 360 degrees about a longitudinal axis thereof. By rotating multilumen catheter
25 420, the segments are positioned properly with respect to the annulus. That is, segment 440 is positioned above a portion of annulus 40 at the base of the posterolateral leaflet, while segment 430 is positioned above a portion of annulus 40 at the base of the anteromedial leaflet.

Following the deployment and expansion of annuloplasty structure 408, catheter
30 421 is pushed distally from within advancement catheter 410, thereby exposing a distal end of steerable catheter 421. Additionally, in some embodiments, multilumen catheter 420 is retracted slightly within advancement catheter 410. Retracting multilumen catheter

420 frees the lumen of the distal end of catheter 410, thereby restoring flexibility to the distal end of catheter 410 and enabling proper steering thereof, e.g., in response to pulling steering wire 413. Structure 408 is pushed toward annulus 40 by pushing on both catheter 410 and on wires 480 and 490. Additionally, the structure is properly aligned with annulus 40 by steering and/or rotating the distal tip of catheter 410, and by steering and/or rotating the distal tip of multilumen catheter 420.

As shown, segment 440 is aligned against the base of posterolateral leaflet 32 at the annulus, and segment 430 is aligned against the base of anteromedial leaflet 34 at the annulus. Segments 430 and 440 are shown prior to anchoring thereof to annulus 40.

Reference is now made to Fig. 19A, which is a schematic illustration of catheter 421 of system 400 being steered toward a given anchor mount 461 of structure 408 and facilitating anchoring of structure 408 to annulus 40, in accordance with an embodiment of the present invention.

Once advancement catheter 410 and multilumen catheter 420 have positioned segments 430 and 440 in their proper orientation with respect to annulus 40, steerable catheter 421 is pushed from within advancement catheter 410, thereby exposing a distal portion of steerable catheter 421. The physician pulls on the proximal end of a first guide member 472 of the plurality of guide members 470. In response to the pulling, catheter 421 is steered toward the distal end of guide member 472, and thereby toward segment 440 and toward an anchor mount 461 which is coupled to the distal end of guide member 472. As the physician pulls the proximal end of guide member 472, he releases the respective proximal ends of guide members 470 not being pulled in order to provide slack to members 470 such that they do not resist movement of catheter 421 toward anchor mount 461. In conjunction with the steering of catheter 421, the physician pushes on a proximal end of catheter 421 so as to push catheter 421 distally toward the location along segment 440 to which it is being steered. As the distal end of catheter 421 is steered toward anchor mount 461, portions of members 470 that are coupled to ring 427 of catheter 421 are also drawn toward anchor mount 461. When the distal end of catheter 421 has been sufficiently steered toward anchor mount 461, catheter 421 is further pushed distally such that distal tapered end 429 of catheter 421 slides partially within channel 460 of anchor mount 461.

At a site proximal to catheter 404, and outside the body of the patient, the physician slides a first anchoring system through the lumen of catheter 421. The anchor is advanced via the anchoring system through the lumen of catheter 421 toward structure 408, through a lumen of distal tapered end 429, and subsequently inserted, in part, into channel 460 of anchor mount 461. For embodiments in which catheter 410 is coupled to the handle assembly, as described hereinabove, the anchor is introduced within the lumen of catheter 421 from a proximal opening within the handle which provides an access to the lumen of catheter 421. In some embodiments, the handle comprises a hemostatic valve at the opening. The anchor of the anchoring system is ultimately further advanced through tissue of annulus 40. As shown, the anchor of the anchoring system comprises a helical anchor 740 having a pointed distal tip 750 configured to puncture tissue of annulus 40. Anchor 740 is corkscrewed into tissue of annulus 40. It is to be noted that helical anchor 740 is shown by way of illustration and not limitation. For example, any anchor described herein as well as any suitable tissue anchor known in the art may be passed through the lumen of catheter 421 and used to anchor structure 408 to annulus 40 of mitral valve 30.

Fig. 19B shows catheter 421 being advanced toward anchor mount 461 of segment 440, in accordance with an embodiment of the present invention. Guide member 472 is pulled such that it is made taut and enables steering of catheter 421 toward anchor mount 461 to which guide member 472 is coupled. Guide members 470 that are not being pulled are shown as being in a relaxed, passive, slackened state. Typically, at least a distal portion of catheter 421 comprises a plurality of compressible subunits, e.g., accordion- or bellow-shaped structures, a braided mesh, or a plurality of coils, which enable steering and maneuvering of catheter 421 in the direction of the guide member 470 being pulled.

In some embodiments, once catheter 421 has been steered toward anchor mount 461 in response to pulling guide member 472, guide member 472 is further pulled and catheter 421 is pushed distally, in the direction as indicated by the arrow, in order to advance distal tapered end 429 of catheter 421 toward channel 460 of anchor mount 461.

Reference is now made to Figs. 19C-E, which are schematic illustrations of an anchoring system 2600, in accordance with an embodiment of the present invention. Fig. 19C shows a bar 710 disposed within channel 460. Typically, bar 710 is disposed angularly with respect to an axis of channel 460, and at the base of the channel. It is to be

noted that bar 710 is disposed substantially in parallel with the longitudinal axis of segment 440 (or segment 430) by way of illustration and not limitation. For example, bar 710 may be disposed perpendicularly to the axis of segment 440, i.e., the axis which runs from the first and second openings in the lateral wall of segment 440 between which
5 channel 460 extends.

Anchoring system 2600 comprising an anchor advancement structure 2620, e.g., a rod or a tube, which is reversibly coupled to anchor 740 via an applicator 741. Typically, anchor 740 comprises a helical element whose proximal end is tightly wrapped around a distal projection 743 of applicator 741 coupled to a distal end of advancement structure
10 2620. In some embodiments, anchor 740 has a tendency to expand radially. By being advanced through the lumen of catheter 421, radial expansion of anchor 740 is inhibited as anchor 740 is advanced therein. Anchoring system 2600 is advanced partially within channel 460, as shown in Fig. 19C.

It is to be noted that applicator 741 is shown by way of illustration and not
15 limitation, and that that scope of the present invention includes the use of anchor 740 independently of applicator 741. In such an embodiment, the proximal end of anchor 740 is tightly wrapped around a distal end of advancement structure 2620 and is decoupled therefrom in a manner as will be described hereinbelow with reference to the decoupling of anchor 740 from projection 743 of applicator 741.

20 Reference is now made to Fig. 19D. Anchoring of anchor 740 begins when the physician rotates advancement structure 2620 about a longitudinal axis thereof, as indicated by the arrow. Such rotation corkscrews a distal portion of the helical element around and beyond bar 710 and subsequently into annulus 40 of the patient.

Reference is again made to Fig. 19C. As described hereinabove, channel 460 has
25 a diameter between about 0.8 mm and 2.5 mm, typically 1.8 mm. Diameter is thus sized in order to enable passage of anchor 740 through channel 460. Typically, anchor 740 configured for passage through channel 460 has a diameter D3 of between about 0.5 mm and 2.4 mm, e.g., 1.6 mm. Typically, each coil of the coiled, helical element has a diameter D4 of between about 0.2 mm and 0.6 mm, e.g., 0.3 mm.

30 Typically, the helical element of anchor 740 is shaped to define at least two adjacent distal rotational subunits 720 and at least two adjacent proximal rotational subunits 730. A distance D11 (e.g., between about 0.3 mm and about 2.0 mm) between

adjacent distal rotational subunits 720 is typically greater than a distance Di_2 (e.g., between about 0 mm and about 0.6 mm) between adjacent proximal rotational subunits 730. Typically, a diameter of bar 710 is less than distance Di_1 and greater than distance Di_2 . Distance Di_1 enables distal rotational subunits 720 to be corkscrewed around and beyond bar 710 and subsequently into annulus 40 of the patient. Distance Di_2 is typically less than a diameter of bar 710, and therefore restricts proximal rotational subunits 730 from being corkscrewed fully around bar 710 and into annulus 40.

During an attempt to corkscrew proximal rotational subunits 730 around bar 710, bar 710 restricts the rotation of subunits 730 therearound and applies a counterforce to a torque applied by rotation of structure 2620. The counterforce applied by bar 710 expands proximal subunits 730 radially such that subunits 730 are no longer wrapped tightly around the projection 743 of applicator 741. Following the expansion of subunits 730, anchor 740 is released from projection 743 of applicator 741, typically by pulling on structure 2620 while continuing to apply a rotational, helix-expanding force to proximal subunits 730. Structure 2620 and applicator 741 coupled thereto is then pulled proximally within the lumen of catheter 421 and extracted from within the body of the patient, as shown in Fig. 19E. During the removal of structure 2620 from heart 20, guide member 470 typically remains within system 400, and it is later decoupled from anchor mount 461.

In some embodiments of the present invention, a few coils of the helical element are wrapped around projection 743, while the remaining coils extend distally from a distal end of projection 743. Typically, a smaller number of coils are wrapped around projection 743 than the number of coils that extend distally from the distal end of projection 743 and are not wrapped around projection 743. As shown by way of illustration and not limitation, three coils are wrapped around projection 743, while four coils are disposed distally to the distal end of projection 743. The coils wrapped around projection 743 generally provide enough frictional force to maintain their position around projection 743 of applicator 741.

In some embodiments, a protrusion (not shown) is typically disposed along projection 743 adjacent to the proximal-most tip of the helical element of anchor 740. During initial implantation of the anchor within annulus 40 of the patient (i.e., as structure 2620 is rotated), the protrusion applies a circumferentially-directed pushing force to the proximal-most tip of the helical element. By pushing on the proximal-most tip of the

helical element, the protrusion typically adds to the frictional force described above, in order to rotate anchor 740. One or both of these forces enable a distal end of anchor 740 to puncture annulus 40. As anchor 740 is advanced into tissue of annulus 40, a portion of proximal rotational subunits of anchor 740 slides distally along projection 743 and away
5 from the protrusion.

Following implantation within annulus 40 of distal rotational subunits 720, the distal end of projection 743 is impeded by bar 710. The physician continues to rotate structure 2620 such that the proximal-most tip of anchor 740 continues to slide distally from the protrusion while the entire anchor 740 continues to be advanced distally within
10 tissue of annulus 40.

During the continued rotation of structure 2620, fewer rotational subunits are wrapped around projection 743, thereby reducing friction between anchor 740 and projection 743. After a sufficient number of rotations, the minimal friction between anchor 740 and projection 743 enables the physician to pull on structure 2620 in order to
15 applicator 741 from anchor 740.

As shown in Fig. 19E, once anchor 740 has been implanted within tissue of the annulus, catheter 421 is moved away from anchor mount 461 responsively to the pulling on a different guide member 470, as will be described hereinbelow, and to the proximal retracting of catheter 421.

Reference is now made to Figs. 20A-B, which are perspective schematic illustrations of catheter 421 of system 400 anchoring annuloplasty structure 408 to annulus 40, in accordance with respective embodiments of the present invention. Catheter 421 is advanced toward anchor mount 461 of segment 430 in order to anchor segment 430 to annulus 40 at the base of anteromedial leaflet 34. A second guide member 474 of the
20 plurality of guide members 470 is pulled in order to steer catheter 421 toward anchor mount 461 coupled to guide member 474. Once distal tapered portion 429 is advanced partially within channel 460 of anchor mount 461, an anchoring system advances an anchor through the lumen of catheter 421, through the lumen of distal tapered tip 429, through channel 460, and subsequently into tissue of the annulus of the patient, as
25 described hereinabove with reference to Fig. 19A-E.

As guide member 474 is pulled, the remaining guide members 470 that are not being pulled are released, in order to provide catheter 421 freedom to move toward guide

member 474 and anchor mount 461 coupled thereto. As shown in Fig. 20A, portions of guide members 470 not being pulled and that are disposed distally to and in the vicinity of ring 427 are pulled toward anchor mount 461 coupled to guide member 470. In conjunction with the steering of catheter 421, catheter 421 is pushed distally in order to be advanced distally toward the anchor mount to which it is being steered.

Fig. 20B shows segments 430 and 440 anchored to annulus 40. A respective anchor 740 has been passed through each channel 460 of each anchor mount 461. In order to anchor structure 408 to annulus 40, catheter 421 is steered toward each anchor mount 461 by pulling on the respective guide member 470 coupled to each anchor mount. When distal end 429 of catheter 421 is positioned at a given anchor mount, an anchor is passed through the lumen of catheter 421 from a site outside the body of the patient and is advanced through catheter 421 by an anchor advancement system.

Catheter 421 may be steered toward the anchor mounts in any sequence thereof. For example, by pulling on a guide member coupled to an anchor mount of segment 440, catheter 421 may be steered first toward segment 440 in order to anchor structure 408 to annulus 40 at the base of posterolateral leaflet 32. The physician may then want to anchor structure 408 to annulus 40 at the base of anteromedial leaflet 34 by pulling on a guide wire coupled to an anchor mount of segment 430. In some embodiments, each guide member 470 is colorized in order to enable the physician to determine toward which anchor mount, and thus, to which location along annulus 40, catheter 421 is being steered in response to the pulling of a given guide member.

For some embodiments in which system 400 comprises a handle assembly coupled to advancement catheter 410, as described hereinabove, the proximal ends of each guide member 470 are pulled and released by at least one switch mechanism coupled to the handle. In some embodiments, each guide member 470 is controlled by a respective switch, and each switch is labeled with a suitable label indicating a position along structure 408 to which the guide member is coupled. For example, guide members 470 coupled to segment 440 may be labeled P_1 to P_n , and guide members 470 coupled to segment 430 may be labeled A_1 to A_n .

In some embodiments, catheter 421 is preloaded with a plurality of anchors, e.g., helical anchors or anchors as shown herein, or any other suitable anchor. When distal end 429 is steered toward each anchor mount 461, a pushing rod pushes on the proximal-most

anchor in order to apply a force to the distal-most anchor disposed within the lumen of catheter 421 until the distal-most anchor is pushed through channel 460 of the respective anchor mount 461.

Typically, following anchoring of structure 408 to the annulus by implanting every anchor within the annulus, a cutting means is advanced through catheter 421. Catheter 421 is steered toward each anchor mount 461 (i.e., in a manner as described hereinabove) and the cutting means cuts the respective guide member coupled to each mount toward which catheter 421 is steered. As such, each guide member 470 is decoupled from the respective anchor mount 461.

In some embodiments, catheter 421 is extracted from within the body of the patient, and an overtube comprising a cutting means disposed therein is slid along each one of guide members 470 and toward the respective anchor mount to which the guide member is coupled. The cutting means then cuts the guide member, and the cutting means and the guide member are then extracted from within the body of the patient. Subsequently, the overtube is then reintroduced within the body of the patient by being slid along a second one of the guide members in order to decouple that guide member from the annuloplasty structure.

In some embodiments, once catheter 421 has been steered to a first location of the annuloplasty structure by pulling on a first one of guide members 470, and the anchor advancement structure (a) advances the anchor through catheter 421 and toward the annulus, (b) facilitates anchoring of the annuloplasty structure to the annulus, and (c) is decoupled from the anchor, the anchor advancement structure is extracted from within catheter 421. Subsequently, the cutting means is introduced within catheter 421 and is advanced through catheter 421 toward the anchor mount coupled to the first guide member. The cutting means cuts the guide member coupled to the anchor mount and is then extracted from within catheter 421 together with the cut guide member. Catheter 421 is then steered toward a second location of the annuloplasty structure by pulling on a second guide member 470. A second anchor is advanced to the second location and anchors the annuloplasty structure to the annulus at the second location. Following the anchoring, the second guide member is cut as described hereinabove. As such, each guide member 470 is systematically cut following implanting of the respective anchor in the vicinity of the location along the annuloplasty structure to which the respective guide member is coupled.

In some embodiments, a respective distal portion of each guide member 470 (i.e., a portion of guide member 470 that is proximal to the portion of guide member 470 that is coupled to anchor mount 461) comprises a material configured to dissolve after being exposed within heart 20 of the patient for a period of time, e.g., between 15 minutes and 90 minutes. In such an embodiment, following anchoring of structures 740 to annulus 40 as described hereinabove, the respective distal portions of each guide member 470 dissolves, thereby decoupling guide member 470 from the respective anchor mount 461. Each guide member 470 is then pulled from its proximal end until its distal end is extracted from within the body of the patient.

In some embodiments, after anchoring annuloplasty structure 408 to annulus 40, one of control wires 480 or 490, e.g., control wire 480, is extracted from within segments 430 and 440 when the physician pulls on a first end of wire 480. Subsequently, the physician replaces control wire 490 with a contracting wire, e.g., a tensile suture, (not shown) by (a) tying a first end of the contracting wire to a first end of wire 490, and then (b) pulling on a second end of wire 490. The physician holds onto a second end of the contracting wire and pulls wire 490 until the first end of the contracting wire has replaced control wire 490 in segments 430 and 440, e.g., until the second end of the contracting wire is once again exposed outside the body of the patient. An intracorporeal portion of the contracting wire remains disposed within both segments 430 and 440. The contracting wire comprises a flexible and/or superelastic material, e.g., nitinol, polyester, ePTFE, PTFE, stainless steel, or cobalt chrome, and is configured to reside chronically within segments 430 and 440. In some embodiments, the contracting wire is coated with polytetrafluoroethylene (PTFE). In some embodiments, the contracting wire comprises a braided polyester suture (e.g., Ticron). Additionally, the contracting wire is configured to withstand cardiac forces and constant motion of segments 430 and 440 that result from the motion of annulus 40. As such, the contracting wire typically has a relatively thick diameter of between about 0.1 mm and about 1.0 mm, typically between about 0.2 mm and about 0.4 mm.

In some embodiments, two contracting wires reside chronically within segments 430 and 440. In such an embodiment, a first tensile suture replaces control wire 480, and a second tensile suture replaces control wire 490. Control wires 480 and 490 are replaced as described hereinabove.

In any embodiment, using tactile feedback, or echocardiography, and optionally in combination with fluoroscopic imaging, first and second ends of the contracting wire(s) are pulled to an extent that is based on (a) the level of dilation of the preoperative mitral valve, and/or (b) real-time monitoring of regurgitation minimization.

5 Typically, for embodiments in which a contracting wire is used, a lock is advanced around the first and second ends of the contracting wire and secures together the ends of the contracting wire, and thereby secures segments 430 and 440 of annuloplasty structure 408, thereby defining its final configuration within annulus 40 of mitral valve 30. The excess portions of the contracting wire are clipped proximally to the lock and are
10 extracted from the body via catheter 404. Following clipping, first and second clipped ends of the contracting wire remain accessible for future tightening together of segments 430 and 440 upon need therefor. In some embodiments, the first and second ends of the contracting wire are located using fluoroscopy or any other method described herein.

Reference is now made to Figs. 17G-J, 18A-B, 19A-E, and 20A-B. It is to be
15 noted that two annuloplasty ring segments 430 and 440 are shown by way of illustration and not limitation. For example, annuloplasty structure 408 may comprise only one segment of segments 430 and 440. In some embodiments, annuloplasty structure 408 may comprise one elongate segment having a length of the combined lengths L1 and L2 (shown in Fig. 17H) of segments 430 and 440, respectively, or any other suitable length
20 according to the needs of a given patient, e.g., according to the extent of dilation of the annulus of the mitral valve.

It is to be additionally noted that use of a helical anchor 740 is described herein by way of illustration and not limitation, and that the scope of the present invention includes the use of other apparatus for anchoring annuloplasty structure 408 to annulus 40. For
25 example, anchor 740 may comprise a screw, harpoon, barb, or any other anchoring structure or anchor known in the art. In some embodiments, anchor 740 comprises a wire configured to penetrate annulus 40 in a generally straight configuration and to subsequently assume a curved configuration once inside tissue of annulus 40. It is to be noted that any anchoring structure, anchor and/or anchoring system described herein with
30 reference to Figs. 1, 4, 5A, 5C, 12, 13A-E, 14A-B, and 15 may be used to anchor structure 408 independently of or in combination with bar 710 shown in Figs. 19B-E. It is to be noted that anchor mount 461 shown in Figs. 19A-E may be used independently of or in combination with bar 710. In some embodiments, channel 1200 described hereinabove

with reference to Fig. 11 may be used independently of or in combination with anchor mount 461 shown in Figs. 19A-E. It is to be further noted that anchor mounts 461 shown in Figs. 17G-J, 18A-B, 19A-E, and 20A-B may comprise any one of anchor mounts 461 shown in Figs. 3-4, 5A-C, and 8-10.

5 It is to be further noted that segments 430 and 440 are shown as comprising mounts 461 by way of illustration and not limitation. For example, segments 430 and 440 may each comprise only one elongate compressible subunit 450, and each guide member 470 may be coupled to segments 430 and 440 at any respective suitable location along the compressible subunit 450.

10 By reducing a circumference of annulus 40, leaflets 32 and 34 are drawn toward one another to prevent recurring dilation of mitral valve 30, restore leaflet coaptation, and reduce mitral regurgitation.

15 It is to be noted that in some embodiments of the present invention, guide members 470 comprise a screw at a distal end thereof. In such an embodiment, each guide member 470 is screwed in to a respective anchor mount 461. Following the steering of catheter 421 toward the anchor mount and the anchoring of the annuloplasty structure to the annulus of the patient, the guide member is decoupled from the anchor mount by rotating the proximal end of the guide member from outside the body of the patient. The guide member is then extracted from the body of the patient via catheter 404.

20 It is to be noted that anchor mount 461 shown in Figs. 1, 3, 4, 5A, 5C, and 8-10 may be used in combination with any of the annuloplasty structures described herein. In some embodiments, a given annuloplasty structure may comprise a plurality of identical anchor mounts 461. In some embodiments, a given annuloplasty structure may comprise a plurality of various types of anchor mounts 461 described herein.

25 It is to be noted that the scope of the present invention is not limited to minimally-invasive procedures (e.g., transcatheter procedures such as percutaneous or intercostal penetration procedures), and includes applications in which system 400 is applied in invasive procedures such as open-heart surgery.

30 It is to be noted that the annuloplasty structures described herein may be advanced toward the annulus using a percutaneous approach, a minimally-invasive approach and/or an open-heart approach.

Reference is again made to Figs. 17A-J, 18A-B, 19A-E, and 20A-B. It is to be noted that system 400 is shown as being used in a percutaneous transcatheter access to the left atrium of the patient by way of illustration and not limitation. It is to be noted that system 400 may be used for anchoring annuloplasty structure 408 to annulus 40 during an open-heart procedure. For example, the left atrium may be exposed following an incision in a wall of heart 20. As mitral valve 30 is exposed, the patient is connected to a cardiopulmonary bypass pump which maintains the circulation of blood and the oxygen content of the patient's body during the exposing of valve 30. Catheter 404 is placed in the left atrium and segments 430 and 440 are pushed from within advancement catheter 410. In some embodiments, segments 430 and 440 are disposed externally to catheter 410 prior to placing catheter 404 in the left atrium. Segments 430 and 440 are then anchored to annulus 40 as described hereinabove. The wall of heart 20 is sutured around catheter 404, typically using a purse stitch, and the patient is disconnected from the cardiopulmonary bypass pump in order to restore function to heart 20. In such an embodiment, the physician is able to reduce the circumference of valve 30 in response to feedback from fluoroscopic and/or ultrasound real-time imaging of the function of valve 30 in a beating heart. Typically, the physician reduces the circumference while viewing the mitral regurgitation in real-time and tightens structure 408 responsively to the extent to which the regurgitation is reduced. For embodiments in which a minimally-invasive approach is used, system 400 may be introduced into the heart either through an intercostal access from the left side of the patient or through an intercostal access from the right side of the patient.

Reference is again made to Figs. 17A-J, 18A-B, 19A-E, and 20A-B. In some embodiments, a distal end of each guide member 470 may be fixedly coupled to a distal portion of catheter 421, while a distal portion of each guide member 470 (i.e., a portion of guide member 470 proximal to the distal end thereof) is reversibly coupled to respective segments 430 and 440 by being looped within respective portions of segments 430 and 440 that are typically adjacent to channel 460 of each respective anchor mount 461. Such looping of the guide member creates a channel for slidable motion of the guide member. Remaining portions of the respective guide members 470 are disposed (a) within catheter 410 and run proximally alongside catheter 421, or in some embodiments, (b) within respective secondary lumens of multilumen catheter 420. In some embodiments, the remaining portions of guide members 470 are passed through respective channels within

ring 427 of catheter 421. It is to be noted that in such an embodiment, catheter 421 may be used independently of ring 427.

In such an embodiment, catheter 421 is steered toward a first location along either segment in response to pulling of a guide member 470 coupled to the segment at the first
5 location (as described hereinabove). As the guide member is pulled, the distal portion of guide member 470 slides within the channel thereby (a) allowing the remaining portions of guide member 470 to be fed proximally within catheter 410, and (b) pulling the distal end of guide member 470, and thereby catheter 421, toward the first location. An anchor is then passed through catheter 421, as described hereinabove, and catheter 421 facilitates
10 anchoring of structure 408 to the annulus at the first location.

Once catheter 421 has facilitated anchoring of annuloplasty structure 408 to the annulus using a plurality of anchors, catheter 421 is extracted from within the body of the patient by being pulled proximally. As catheter 421 is pulled, the physician released the proximal ends of guide members 470, and guide members 470, coupled at distal ends
15 thereof to catheter 421, are pulled together with catheter 421. As catheter 421 is pulled, the proximal ends of guide members 470 are fed into advancement catheter 410 and toward the annuloplasty structure. The proximal ends of the guide members then trail the distal ends of the guide members as they are looped through the annuloplasty structure and then fed back through advancement catheter 410. As guide members 470 are pulled,
20 they are slid from within their respective channels, and are thereby decoupled from structure 408.

Figs. 21-22 are schematic illustrations of a handle assembly 2800 configured for use in an open-heart and/or a minimally-invasive procedure to deliver annuloplasty structure 100 as described hereinabove with reference to Fig. 1, in accordance with an
25 embodiment of the present invention. Handle assembly 2800 comprises a handle 2802 and semi-flexible multitube portion 2808 coupled at a proximal end thereof to a distal end of handle 2802. Multitube portion 2808 comprises a plurality of tubes 2810 coupled and bound together by stabilizing rings 2812 and 2820. In some embodiments, a sheath surrounds tubes 2810 and is hermetically sealed at a distal end thereof to ring 2820 and at
30 a proximal end thereof to a distal end of handle 2802. A respective distal end of each tube 2810 is coupled to structure 100 via a respective anchor mount 461. As such, the respective distal portions of tubes 2810 are flexible such that each tube 2810 branches radially. It is to be noted that a contracting wire is disposed within structure 100 (as

described hereinabove with reference to Fig. 1), and is not shown for clarity of illustration. In some embodiments, handle assembly 2800 is disposable.

As shown in Fig. 21, a distal end 2840 of each tube 2810 is positioned against a first lateral surface of a respective anchor mount 461 in alignment with a proximal opening of channel 460 of anchor mount 461. Typically, a longitudinal axis of channel 460 is transverse with respect to the longitudinal axis of anchor mount 461. Fig. 22 shows contracting wire 110 of annuloplasty structure 100 coupled to tubes 2810. It is to be noted that compressible units 450 and anchor mounts 461 (shown in Fig. 21) are not shown for clarity of illustration. Each distal end 2840 of tubes 2810 is coupled to a contracting wire coupling element 2830, i.e., an extension or projection, at a proximal end thereof. Each contracting wire coupling element 2830 is shaped to define a hole at a distal portion thereof configured for slidable passage therethrough of at least a portion of contracting wire 110. As shown in Fig. 21, each contracting wire coupling element 2830 passes through an opening (e.g., a second channel, a hole, or a groove that is distinct from channel 460 and has a longitudinal axis that is transverse with respect to the longitudinal axis of anchor mount 461) in a respective anchor mount 461. Each contracting wire coupling element 2830 is configured to surround contracting wire 110 passing through mount 461 and enables slidable advancement therethrough of contracting wire 110.

As shown in Fig. 22, tubes 2810 and distal ends 2840 thereof are shaped to define a hollow lumen 2805 configured for passage of a respective anchor through each tube 2810, through distal end 2805, through channel 460 of anchor mount 461, and subsequently into tissue of the patient. Fig. 21 shows helical anchors 740 coupled to structure 100 via mounts 461. A cross-sectional illustration of proximal end 2801 of handle 2801 (Fig. 22) shows proximal end 2801 being shaped to define a plurality of proximal openings lumens 2803. Handle 2802 is shaped to define a plurality of lumens 2803 whose distal ends are accessed by respective proximal ends of tubes 2810. In some embodiments, each lumen 2803 is labeled at proximal end 2801 with a suitable label indicating to which portion of the annulus the anchor passed through a given lumen will be anchored. For example, lumens 2803 that are configured to deliver respective anchors to the annulus at the base of the anteromedial leaflet, are labeled A_1 - A_n , in accordance with the number of desired anchoring sites along the annulus at the base of the anteromedial leaflet. Similarly, lumens 2803 that are configured to deliver respective anchors to the annulus at the base of the posterolateral leaflet, are labeled P_1 - P_n , in

accordance with the number of desired anchoring sites along the annulus at the base of the posterolateral leaflet.

An anchor is advanced into each lumen 2803 through a respective opening in proximal end 2801 of handle 2802. An anchor advancement system, e.g., a rod as
5 described hereinabove, advances each anchor through a respective lumen 2803, through tube 2810 accessing lumen 2803, and toward anchor mount 461 coupled to that tube. In some embodiments, tubes 2810 are preloaded with a respective anchor, and once annuloplasty structure 100 is positioned at the annulus, an anchor advancement rod is advanced through each lumen in order to facilitate advancing of the anchor into tissue of
10 the patient. In some embodiments, tubes 2810 are each preloaded with a respective anchor and a respective rod coupled at a distal end thereof to each anchor. A proximal end of each rod is accessible from proximal end 2801 of handle 2802 by a physician who is able to push and/or rotate the rod in order to facilitate advancing of the anchor into tissue of the patient.

15 A portion of contracting wire 110 is configured to be disposed within a lumen of structure 100, as described hereinabove. The remaining portions of contracting wire 110 are slidably disposed within (a) housing 610, (b) a tube 2811 of tubes 2810, and (c) handle 2802. Handle 2802 comprises first, second, and third rotating rings 2804, 2806, and 2807, respectively. Typically, a portion, e.g., an end, of a first end of contracting wire 110 is
20 coupled to second rotating ring 2806, and a portion, e.g., an end, of a second end of contracting wire 110 is coupled to third rotating ring 2807. Once anchors 740 have been anchored to tissue of the patient, and structure 100 has been anchored thereby to the annulus, a portion of contracting wire 110 is pulled in order to reduce the perimeter/size of the portion of contracting wire 110 that is disposed within structure 100. Contracting
25 wire 110 is pulled when the first and/or second ends thereof are drawn proximally in response to rotating rings 2806 and/or 2807. For example, as ring 2806 is rotated, a portion of the first end of contracting wire 110 is wrapped around a threaded element (not shown) disposed within handle 2802 and pulls contracting wire 110 proximally. As wire
30 110 is pulled proximally, the portion of wire 110 disposed within the lumen of structure 100 slides through the holes of contracting wire coupling elements 2830, and a portion of the portion of wire 110 that was originally disposed within the lumen of structure 100 slides proximally out of the lumen of structure 100 and toward handle 2802. In some

embodiments, ring 2806 may be rotated as ring 2807 remains stationary, or vice versa. In some embodiments, rings 2806 and 2807 are rotated opposite directions.

Typically, ring 2804 locks rings 2806 and 2807 in place, thereby locking contracting wire 110 in a given perimeter as defined by the rotating of rings 2806 and 2807. It is to be noted that three rings 2804, 2806, and 2807 are shown by way of illustration and not limitation.

Using tactile feedback, or echocardiography, and optionally in combination with fluoroscopic imaging, the first and second ends of contracting wire 110 are pulled to an extent that is based on (a) the level of dilation of the preoperative mitral valve, and/or (b) real-time monitoring of regurgitation minimization. For embodiments in which structure 100 comprises a ratchet mechanism, as described hereinabove with reference to Figs. 1, 2A-B, 3, 4, 5A-C, 6A-B, and 7, the ratchet mechanism maintains the ratcheted perimeter of structure 100 following the pulling of wire 110. Contracting wire 110 is then pulled from within the lumen of structure 100 by cutting a first portion of wire 110 and then pulling on a first end of contracting wire 110, e.g., by pulling proximally on assembly 2800.

In some embodiments, the first and second ends of contracting wire 110 are exposed proximally to rings 2806 and 2807, respectively. In such an embodiment, following the adjustment of annuloplasty structure 100 by rotating rings 2806 and 2807, ring 2804 is rotated in order to unlock rings 2806 and 2807 which are, in turn, allowed to rotate so as to unwind the portion of contracting wire 110 from the threaded element in handle 2802. One of the ends of the contracting wire is then pulled in order to remove contracting wire 110 from structure 100. A first end of contracting wire 110 is pulled such that the second end of the contracting wire is pulled (a) distally through tube 2811, (b) through housing 610, (c) through each hole of contracting wire coupling elements 2830, (d) back through housing 610, (e) pulled proximally back through tube 2811, until the second end of contracting wire 110 is exposed outside the body of the patient.

In some embodiments, the first and second ends of wire 110 are fixedly coupled to rings 2806 and 2807. In such an embodiment, in order to remove contracting wire 110 from within structure 100, tube 2811 is cut together with at least one portion of wire 110, and wire 110 is then pulled from within the lumen of structure 100. By pulling on wire

110 and freeing wire 110 from within structure 110 and from contracting wire coupling elements 2830, handle assembly 2800 is decoupled from structure 100.

Once contracting wire 110 is removed from within the holes of contracting wire coupling elements 2830, tubes 2810 are decoupled from structure 100 by pulling handle
5 2802 and/or tubes 2810 proximally such that contracting wire coupling elements 2830 are pulled from within anchor mounts 461. Handle assembly 2800 is pulled proximally leaving structure 100 coupled to the annulus of the patient.

In some embodiments, compressible subunits 450 comprise a coil, and the anchor used to anchor structure 100 to the annulus comprises a helical coil comprising coils
10 which are coiled around a portion of coils of tubular, compressible subunits 450 of the annuloplasty structure and subsequently through the tissue of the annulus of the patient. In such an embodiment, the annuloplasty structure does not comprise anchor mounts 461, and the distal ends of tubes 2810 are positioned at a first lateral surface of compressible subunits 450 of the annuloplasty structure. During the manufacture of assembly 2800, the
15 annuloplasty structure is coupled to each tube 2810 by passing a respective contracting wire coupling element 2830 between adjacent coils of compressible subunits 450. Contracting wire 110 is then fed through the respective holes defined by each contracting wire coupling element 2830. Following the coiling of the coils of the anchor around a
20 portion of coils of compressible subunits 450, the contracting wire is pulled from within the lumen of the annuloplasty structure, and from within each hole of contracting wire coupling elements 2830. Handle assembly 2800 is thereby detached from the annuloplasty structure and can be pulled proximally therefrom.

It is to be noted that although helical anchors 740 are shown, the scope of the present invention includes the use of any anchor described herein.

25 In some embodiments, annuloplasty structure 100 does not comprise anchor mounts 461 but rather comprises a braided mesh. In either embodiment in which structure comprises or lacks anchor mounts 461, prior to advancement of structure 100 by handle assembly 2800, a plurality of sutures are sutured at respective locations along the annulus of the valve. Respective ends of each of the sutures are then threaded at respective
30 locations through structure 100. Structure 100 is then slid along the sutures and toward the annulus of the valve by being pushed by handle assembly 2800. Once positioned at the annulus, the sutures are locked in place at the exposed lateral surface of structure 100.

In some embodiments, a bead is slid distally along each suture, and is secured in place by crimping, an adhesive, or a ratcheting mechanism, thereby locking the suture in place proximal to structure 100. The remaining portions of the suture are then cut proximally to the bead. In some embodiments, respective portions of one suture or of two adjacent sutures are knotted together in order to lock the suture(s) in place. The remaining portions of the suture(s) are then cut proximally to the knot.

It is to be noted that although structure 100 is shown as being coupled to handle assembly 2800, the scope of the present invention includes the use of handle assembly 2800 to advance structure 408 as described hereinabove with reference to Figs. 17G-J, 18A-B, 19A-E, and 20A-B. For example, handle assembly 2800 may advance segments 430 and/or 440.

For embodiments in which a minimally-invasive approach is used, system 2800 may be introduced into the heart either through an intercostal access from the left side of the patient or through an intercostal access from the right side of the patient.

It is to be noted that handle assembly 2800 (Figs. 21 and 22) may be used for anchoring the annuloplasty structures described herein to the annulus during an open-heart procedure. For example, the left atrium may be exposed following an incision in a wall of the heart. As the mitral valve is exposed, the patient is connected to a cardiopulmonary bypass pump which maintains the circulation of blood and the oxygen content of the patient's body during the exposing of the valve. Once the annuloplasty structure is positioned along the annulus of the valve and anchored thereto, the wall of the heart is sutured around the tubular portions of handle assembly 2800 (i.e., multitube portion 2808 of assembly 2800), typically using a purse stitch, and the patient is disconnected from the cardiopulmonary bypass pump in order to restore function to the heart. The physician is able to reduce the perimeter of the annulus in response to feedback from fluoroscopic and/or ultrasound real-time imaging of the function of the valve in a beating heart. Typically, the physician reduces the perimeter while viewing the mitral regurgitation in real-time and tightens the annuloplasty structure responsively to the extent to which the regurgitation is reduced.

Figs. 23A-B are schematic illustrations of an annuloplasty structure system 3100 comprising a tubular ratchet mechanism 3101; in accordance with an embodiment of the present invention. Typically, ratchet mechanism 3101 is surrounded by a compressible,

tubular surrounding 450. Ratchet mechanism 3101 comprises a first tubular element 3102 and a second tubular element 3106 spaced apart from each other at first ends thereof. Tubular element 3102 is coupled at a second end thereof to a first tubular coupling member 3105, and tubular element 3106 is coupled at a second end thereof to a second tubular coupling member 3107. As shown in Fig. 23B, first tubular coupling member 3105 comprises a first coupling site 3122 configured for coupling thereto a first end of compressible, tubular surrounding 450 (Fig. 23A), and second tubular coupling member 3107 comprises a second coupling site 3124 configured for coupling thereto a second end of compressible, tubular surrounding 450 (Fig. 23A).

10 During the manufacture of system 3100, while holding a first end of contracting wire 110 in place outside system 3100, a second end of contracting wire 110 is fed through (a) a hole 3120 defined by second tubular coupling member 3107, (b) second tubular coupling member 3107, (c) tubular element 3106, (d) tubular member 3102, (e) first tubular coupling member 3105, (f) a portion of second tubular coupling member 3107, and finally back through hole 3120. Typically, contracting wire 110 is configured for slidable advancement within system 3100.

Typically, during open-heart and minimally-invasive procedures, system 3100 is advanced toward the annulus of the mitral valve of the patient in the configuration shown in Fig. 23A, i.e., first and second ratchet tubular coupling members 3105 and 3107, respectively, are coupled together. For embodiments in which system 3100 is used during a percutaneous procedure (and in some embodiments, during open-heart and minimally-invasive procedures), system 3100 is disposed within an advancement catheter in a linear configuration thereof. That is, (a) compressible, tubular surrounding 450 is disposed linearly, thereby defining a longitudinal axis thereof, (b) tubular members 3102 and 3106 are disposed coaxially along the longitudinal axis, (c) first and second tubular coupling members 3105 and 3107, respectively, are not coupled together, but rather are disposed at opposite ends of system 3100 along the longitudinal axis, and (d) contracting wire 110 extends longitudinally within the advancement catheter between first and second tubular coupling members 3105 and 3107 while respective first and second ends of contracting wire 110 are disposed outside the body of the patient.

In such an embodiment, system 3100 is transcatheterally advanced toward the left atrium in a linear configuration thereof while first and second ends of contracting wire 110 are disposed outside the body of the patient. As system 3100 is pushed from within

the advancement catheter and is disposed within the left atrium of the patient, the first and second ends of contracting wire 110 are pulled, thereby pulling first and second tubular coupling members 3105 and 3107 toward each other. In response to continued pulling of contracting wire 110, first and second tubular coupling members 3105 and 3107 are
5 coupled and locked together, and system 3100 assumes a substantially circular configuration, as shown in Fig. 23A.

Typically, first tubular element 3102 has a diameter that is larger than a diameter of second tubular element 3106 such that second tubular element 3106 is allowed to slide through first tubular element 3102. First tubular element 3102 is shaped to define a
10 plurality of first engaging elements (e.g., teeth) 3110 at a receiving portion 3104. Second tubular element 3106 is shaped to define a plurality of second engaging elements (e.g., indented portions 3112) at a feeding portion 3108 thereof. Typically, in response to continued pulling of contracting wire 110, as feeding portion 3108 (i.e., the first end, of second tubular element 3106) is initially fed through receiving portion 3104 (i.e., the first
15 end, of first tubular portion 3102), a first indented portion of indented portions 3112 is slid through receiving portion 3104 until it is aligned and locks in place with a first one of teeth 3110 of receiving portion 3104.

In response to additional force applied to tubular elements 3102 and 3106 by continued pulling of contracting wire 110, the first indented portion of indented portions
20 3112 is disengaged from the first tooth of teeth 3110 and is advanced toward the second tooth of teeth 3110. Typically, pulling on contracting wire 110 controls the spatial relationship between tubular structures 3102 and 3106 which, in turn, control the structural configuration of system 3100. Thus, a perimeter of system 3100 is modulated, i.e., reduced, in response to the compression of surrounding 450 by the inward, radial
25 force applied due to the pulling of contracting wire 110.

It is to be noted that the plurality of teeth 3110 is provided such that tubular elements 3102 and 3106 of ratchet mechanism 3101, and thereby compressible, tubular surrounding 450, lock in place and maintain respective ratcheted perimeters thereof. Such a locking mechanism is applied so as to enable system 3100 to accommodate various sizes
30 of dilated annuli of given patients. Additionally, ratchet mechanism 3101 facilitates: (1) positioning and anchoring of structure system 3100 to the dilated annulus while compressible surrounding 450 has a first perimeter thereof, (2) contracting of the dilated annulus in response to the contracting of ratchet mechanism 3101, and (3) maintaining of

the contracted state of the annulus while tubular elements 3102 and 3106 (and thereby surrounding 450) have a second perimeter thereof that is typically smaller than the first perimeter.

Typically, compressible, tubular surrounding 450 comprises a coil, and the anchor
5 used to anchor system 3100 to the annulus comprises a helical coil comprising coils which are coiled around a portion of coils of compressible, tubular surrounding 450 and subsequently through the tissue of the annulus of the patient, as described hereinabove.

In some embodiments, compressible, tubular surrounding 450 comprises a braided
10 mesh, e.g., metal or fabric such as polyester. In such an embodiment, any anchor described herein may be passed through the braided mesh, and subsequently through the tissue of the annulus, thereby (a) anchoring system 3100 to the annulus, and (b) coupling system 3100 to the anchor. Alternatively, a plurality of sutures may be used to anchor system 3100 to the annulus of the patient.

Once system 3100 is anchored to the annulus of the patient, using real-time
15 monitoring, tactile feedback, or echocardiography, and optionally in combination with fluoroscopic imaging, contracting wire 110 is pulled. Consequently, the leaflets are drawn toward one another in accordance with the level of dilation of the preoperative mitral valve. Thus, generally, the normal structural configuration is returned to the leaflets, effecting a reduction in mitral valve perimeter/size and regurgitation. As
20 contracting wire 110 is pulled, ratchet mechanism 3101 locks system 3100 in place so that system 3100, and thereby the annulus of the patient, assumes and maintains a desired perimeter. While a first end of contracting wire 110 is freed, a second end of wire 110 is then pulled from a site outside the body of the patient until contracting wire 110 is removed from system 3100 and from the body of the patient.

25 It is to be noted that anchors described herein for passage through the braided mesh of the annuloplasty structure, or configured for coiling around a portion of coils of coiled compressible subunits 450, have a diameter of between 0.5 mm and 3.5 mm, e.g., 1.6 mm.

It is to be further noted that systems described herein for treatment of dilated
30 mitral valves may be used to treat valves other than mitral valve 30, *mutatis mutandis*. For example, system 400 and structures 100 and 408 may be used to treat an aortic valve

of the patient or a tricuspid valve. In some embodiments, systems described herein for use with a dilated annulus may be applied in order to treat dilated venous valves.

It is to be still further noted that systems described herein for treatment of mitral valves may be used to treat other annular muscles within the body of the patient. For example, the systems described herein may be used in order to treat a sphincter muscle within a stomach of the patient.

It is also to be noted that the scope of the present invention include the use of the anchors described herein in order to anchor intrabody apparatus other than annuloplasty structures.

The scope of the present invention includes embodiments described in US Patent Application 11/950,930 to Gross et al., filed December 5, 2007, entitled, "Segmented ring placement," which is assigned to the assignee of the present patent application and is incorporated herein by reference.

Additionally, the scope of the present invention includes embodiments described in one or more of the following:

- PCT Publication WO 06/097931 to Gross et al., entitled, "Mitral Valve treatment techniques," filed March 15, 2006;
- US Provisional Patent Application 60/873,075 to Gross et al., entitled, "Mitral valve closure techniques," filed December 5, 2006;
- US Provisional Patent Application 60/902,146 to Gross et al., entitled, "Mitral valve closure techniques," filed on February 16, 2007;
- US Provisional Patent Application 61/001,013 to Gross et al., entitled, "Segmented ring placement," filed October 29, 2007;
- PCT Patent Application PCT/IL07/001503 to Gross et al., entitled, "Segmented ring placement," filed on December 5, 2007;
- US Provisional Patent Application 61/132,295 to Gross et al., entitled, "Annuloplasty devices and methods of delivery therefor," filed on June 16, 2008;
- US Patent Application 12/341,960 to Cabiri, entitled, "Adjustable partial annuloplasty ring and mechanism therefor," filed on December 22, 2008;

- US Provisional Patent Application 61/207,908, to Miller et al., entitled, "Actively-engageable movement-restriction mechanism for use with an annuloplasty structure," filed on February 17, 2009;
- 5 • US Patent Application 12/435,291 to Maisano et al., entitled: "Adjustable repair chords and spool mechanism therefor," filed May 4, 2009; and
- US Patent Application 12/437,103 to Zipory et al., entitled, "Annuloplasty ring with intra-ring anchoring," Filed on May 7, 2009.

All of these applications are incorporated herein by reference. Techniques described herein can be practiced in combination with techniques described in one or
10 more of these applications.

For some applications, techniques described herein are practiced in combination with techniques described in one or more of the references cited in the Background section and Cross-References section of the present patent application. All references cited herein, including patents, patent applications, and articles, are incorporated herein by
15 reference.

It will be appreciated by persons skilled in the art that the present invention is not limited to what has been particularly shown and described hereinabove. Rather, the scope of the present invention includes both combinations and subcombinations of the various features described hereinabove, as well as variations and modifications thereof that are not
20 in the prior art, which would occur to persons skilled in the art upon reading the foregoing description.

CLAIMS

1. Apparatus, comprising:
 - a tube shaped to define a tube lumen;
 - at least one implant reversibly coupled to the tube, and configured for implantation
- 5 within a body of a patient; and
 - two or more longitudinal guide members disposed at least in part along a distal
 - portion of the tube, the longitudinal guide members having distal portions thereof
 - configured to be reversibly coupled to the implant, and arranged such that application of a
 - force to a first one of the longitudinal guide members steers the distal portion of the tube
 - 10 toward a first location along the implant, and application of a force to a second one of the
 - longitudinal guide members steers the distal portion of the tube toward a second location
 - along the implant.
2. The apparatus according to inventive concept 1, wherein the implant is configured
- for transcatheter advancement into an atrium of a heart of the patient.
- 15 3. The apparatus according to any one of claims 1-2, wherein the apparatus further
- comprises a housing configured to surround at least a portion of the tube, the housing
- being shaped to define one or more channels configured for passage therethrough of the
- two or more longitudinal guide members, and wherein the housing is configured to move
- rotationally with respect to a longitudinal axis of the tube.
- 20 4. The apparatus according to claim 3, wherein the elongate segment comprises a
- ratchet mechanism comprising a body portion, a first end shaped to define at least one
- first engaging structure, and a second end shaped to define at least one second engaging
- structure configured to engage the first engaging structure.
5. The apparatus according to claim 4, wherein:
 - 25 the body portion is shaped to define at least one tubular body portion having at
 - least one lumen therein,
 - the apparatus further comprises a wire disposed at least in part within the lumen of
 - the body portion, and
 - the elongate segment is configured to be advanced toward a left atrium of the
 - 30 patient in a generally straight configuration and subsequently to assume a curved
 - configuration in response to a contracting force applied thereto by contraction of the wire.

6. The apparatus according to claim 4, wherein:
the body portion is shaped to define a flat body portion,
the apparatus further comprises a wire disposed at least alongside the body
portion, and
- 5 the elongate segment is configured to be advanced toward a left atrium of the
patient in a generally straight configuration and subsequently to assume a curved
configuration in response to a contracting force applied thereto by contraction of the wire.
7. The apparatus according to claim 3, wherein:
the implant comprises at least one elongate segment,
- 10 the elongate segment comprises two or more anchor mounts each having
longitudinal axes thereof that are transverse to a longitudinal axis of the elongate segment,
and
- each mount is shaped to provide a channel aligned along the longitudinal axis of
the respective anchor mount that is transverse to the longitudinal axis of the anchor
15 mount.
8. The apparatus according to claim 7, wherein application of the force to the first
one of the longitudinal guide members steers the distal portion of the tube toward a first
one of the two or more anchor mounts, and wherein application of the force to the second
one of the longitudinal guide members steers the distal portion of the tube toward a
20 second one of the two or more anchor mounts.
9. The apparatus according to claim 7, wherein a respective one of the two or more
longitudinal guide members is reversibly coupled to each of the two or more anchor
mounts.
10. The apparatus according to claim 9, further comprising at least one anchor
25 configured to be advanced through the lumen of the tube, wherein the anchor is
configured to be advanced through the channel of a first one of the two or more anchor
mounts in response to steering the distal portion of the tube toward the anchor mount by
applying the force to the first one of the longitudinal guide members, and wherein the
longitudinal guide member is configured to be decoupled from the anchor mount
30 subsequent to the anchoring of the anchor to an annulus.
11. Apparatus, comprising:

a tube shaped to define a tube lumen;

at least one implant reversibly coupled to the tube and configured for implantation within a body of a patient; and

5 one or more longitudinal guide members disposed at least in part along a distal portion of the tube, the one or more longitudinal guide members having a distal portions thereof configured to be reversibly coupled to the implant, and arranged such that application of a force to the one or more longitudinal guide members steers the distal portion of the tube toward a first location along the implant.

12. A method for repairing a valve of a body of a patient, the valve including an annulus and at least first and second leaflets, comprising:

advancing a tube shaped to define a tube lumen toward the valve of the patient;

15 advancing toward the valve at least one annuloplasty structure reversibly coupled to the tube and at respective locations thereof to two or more longitudinal guide members at respective distal portions thereof, the longitudinal guide members being disposed at least in part along a distal portion of the tube;

positioning the annuloplasty structure against the annulus of the patient;

steering the distal portion of the tube toward a first location along the annuloplasty structure by pulling a first one of the two or more longitudinal guide members; and

20 steering the distal portion of the tube toward a second location along the annuloplasty structure by pulling a second one of the two or more longitudinal guide members.

13. The method according to claim 12, wherein advancing the tube and the annuloplasty structure comprises transcatheterally advancing the tube and the annuloplasty structure during a single transcatheter advancement thereof.

25 14. The method according to any one of claims 12-13, further comprising:

advancing a first anchor through the lumen of the tube subsequently to steering the tube toward the first location,

30 anchoring the annuloplasty structure at the first location thereof to the annulus by advancing the first anchor through the annuloplasty structure and into tissue of the annulus,

advancing a second anchor through the lumen of the tube subsequently to steering the tube toward the second location, and

anchoring the annuloplasty structure to the annulus at the second location thereof by advancing the second anchor through the annuloplasty structure and into tissue of the annulus.

15. A method for repairing a valve of a body of a patient, the valve including an annulus and at least first and second leaflets, comprising:
- 5 advancing a tube shaped to define a tube lumen toward the valve of the patient;
- advancing toward the valve at least one annuloplasty structure reversibly coupled to the tube and at respective locations thereof to one or more longitudinal guide members at respective distal portions thereof, the one or more longitudinal guide members being
- 10 disposed at least in part along a distal portion of the tube;
- positioning the annuloplasty structure against the annulus of the patient; and
- steering the distal portion of the tube toward a first location along the annuloplasty structure by pulling the one or more longitudinal guide members.

16. Apparatus, comprising:
- 15 a tubular structure having a lumen therein having a longitudinal axis;
- a wire disposed at least in part within the lumen of the tubular structure;
- at least one elongate tube configured to be reversibly coupled at a distal portion thereof to the tubular structure; and
- an extension coupled at a proximal portion thereof to the distal portion of the
- 20 elongate tube, a distal portion of the extension being configured to be disposed within the lumen of the tubular structure and to surround at least a portion of the wire that is disposed at least in part within the lumen of the tubular structure.

17. The apparatus according to claim 16, wherein:
- the tubular structure comprises at least one anchor mount having longitudinal axes
- 25 thereof that is transverse to the longitudinal axis of the tubular structure,
- the anchor mount is shaped to provide at least a first channel aligned along the longitudinal axis of the anchor mount,
- the distal portion of the elongate tube is configured to be disposed proximally to the first channel of the anchor mount,
- 30 the apparatus further comprises at least one anchor configured to anchor the tubular structure to tissue of a patient, and

the anchor is configured to be:

advanced toward the tubular structure via the elongate tube,
advanced through the first channel of the anchor mount, and
implanted within the tissue.

- 5 18. Apparatus, comprising:
a tubular structure having a lumen thereof having a longitudinal axis;
at least one anchor mount coupled to the tubular structure, the anchor mount being
shaped to provide at least one channel having a longitudinal axis that is at a non-zero
angle with respect to the longitudinal axis of the tubular structure; and
10 a ratchet mechanism configured to be disposed within the lumen of the tubular
structure, the ratchet mechanism comprising a body portion, a first end shaped to define at
least one first engaging structure, and a second end shaped to define at least one second
engaging structure configured to engage the first engaging structure, the ratchet
mechanism configured to maintain a ratcheted perimeter of the tubular structure.
- 15 19. The apparatus according to claim 18, wherein the anchor mount is shaped to
define an anchor mount lumen having a longitudinal axis that is parallel with respect to
the longitudinal axis of the tubular structure, and wherein the channel is disposed at the
non-zero angle with respect to the longitudinal axis of the anchor mount lumen.
- 20 20. The apparatus according to claim 19, wherein the ratchet mechanism is configured
to be disposed within the lumen of the tubular structure and within the anchor mount
lumen.
21. The apparatus according to claim 20, wherein the anchor mount lumen has a major
axis that is (a) transverse with respect to the longitudinal axis of the anchor mount lumen
and (b) at a non-zero angle with respect to the longitudinal axis of the first channel.
- 25 22. The apparatus according to claim 21, wherein:
the apparatus comprises a plurality of anchor mounts,
each anchor mount of a first portion of the plurality of anchor mounts has a
respective anchor mount lumen having a major axis that is disposed at a first angle with
respect to the longitudinal axis of the channel, and

each anchor mount of a second portion of the plurality of anchor mounts has a respective anchor mount lumen having a major axis that is disposed at a second angle with respect to the longitudinal axis of the channel.

23. The apparatus according to claim 18, further comprising a wire disposed at least in part within the lumen of the tubular structure, wherein the tubular structure is configured to be advanced toward an atrium of a heart of a patient in a generally straight configuration and subsequently to assume a curved configuration in response to a contracting force applied thereto by contraction of the wire.

24. The apparatus according to claim 23, wherein, in response to the contracting force, the wire is configured to draw together opposite ends of the ratchet mechanism and opposing ends of the tubular structure, and wherein the ratchet mechanism is configured to maintain respective first ratcheted perimeters of the tubular structure and the ratchet mechanism.

25. Apparatus, comprising:
a tubular structure having a lumen therein having a longitudinal axis;
a wire disposed in part within the lumen of the tubular structure, the wire having first and second portions thereof, the first and second portions of the wire being disposed externally to the lumen of the tubular structure; and
a handle assembly comprising at least one rotating element configured to be coupled to the first and second ends of the wire, in a manner in which rotation of the rotating element applies a force to the wire disposed within the tubular structure and adjusts a perimeter of the tubular structure.

26. The apparatus according to claim 25, wherein:
in response to a rotation of the rotating element, the wire is configured to contract the tubular structure to a first perimeter thereof, and
in response to an additional rotation of the rotating element, the wire is configured to contract the tubular structure to a second perimeter thereof, the second perimeter being smaller than the first perimeter.

27. Apparatus for use with tissue of a patient, comprising:

a housing having a lateral wall having a proximal and a distal portion, the lateral wall being shaped to define a channel extending from a first opening in the proximal portion to a second opening in the distal portion, the channel having a longitudinal axis thereof; and

5 an anchor structure configured for passage through the channel and into the tissue, comprising:

a plurality of coils; and

a head portion defining a diameter of the structure that is larger than a diameter of the first opening, the head portion configured to:

10 restrict distal motion of the plurality of coils beyond a predetermined depth by abutting against the first opening of the proximal portion, and

draw tissue proximally by rotation of the head portion around the longitudinal axis of the channel.

15 28. Apparatus, including:

a tubular implant shaped to define an implant lumen;

a flexible longitudinal member disposed within the implant lumen, the flexible longitudinal member having a first end that is slidable with respect to a second end thereof to form the longitudinal member into a closed loop having a perimeter thereof which (a) shortens when the first end is advanced in a first direction with respect to the second end in a first direction, and (b) expands when the first end is advanced with respect to the second end in a second direction opposite to the first direction; and

25 a flexible contracting member being disposed alongside the longitudinal member and within and slidably advanceable through the implant lumen to facilitate reduction of the perimeter of the longitudinal member by application of a compression force to the longitudinal member.

29. The apparatus according to claim 28, wherein the contracting wire facilitates sliding of the first end of the flexible member with respect to the second end in the second direction, even in the absence of a force applied to the contracting wire.

30 30. The apparatus according to claim 28, wherein, in response to a pulling force applied to the contracting member, the flexible member is configured to facilitate compression of the implant, and responsively to the compression of the implant, to

facilitate sliding of the first end of the longitudinal member with respect to the second end in the first direction.

31. The apparatus according to any one of claims 28-30, wherein:

when formed into the closed loop, the longitudinal member is shaped to provide an
5 inner surface and an outer surface with respect to a center of the closed loop,

the flexible contracting member is disposed alongside the longitudinal member
externally to the outer surface thereof, and

in response to the pulling force applied to the contracting wire, the contracting
wire is configured to facilitate sliding of the first end of the longitudinal member with
10 respect to the second end in the first direction.

32. A method, including:

providing:

a tubular implant having an implant lumen,

a flexible longitudinal member disposed within the implant lumen, the
15 flexible longitudinal member having a first end that is slidable with respect to a
second end thereof, and

a flexible contracting member being disposed alongside the longitudinal
member and within and slidably advanceable through the implant lumen, the
flexible longitudinal member having a first end that is slidable with respect to a
20 second end thereof to form the longitudinal member into a closed loop having a
perimeter thereof which (a) shortens when the first end is advanced in a first
direction with respect to the second end in a first direction, and (b) expands when
the first end is advanced with respect to the second end in a second direction
opposite to the first direction; and

25 reducing the perimeter of the longitudinal member by applying a compression
force to the longitudinal member.

33. The method according to claim 32, further comprising facilitates sliding of the first
end of the flexible member with respect to the second end in the second direction, even in
the absence of a force applied to the contracting wire.

30 34. The method according to claim 32, further comprising applying a pulling force to
the contracting member, and wherein applying the compression force to the longitudinal
member comprises:

responsively to the applying the pulling force to the contracting member, compressing the implant, and

responsively to the compressing the implant:

- 5 applying the compression force to the longitudinal member,
 facilitating sliding of the first end of the longitudinal member with respect
to the second end in the first direction, and
 compressing the longitudinal member.

35. The method according to any one of claims 32-35, wherein:

- 10 the method further comprises forming the longitudinal member into the closed
loop wherein the flexible member has an inner surface and an outer surface with respect to
a center of the closed loop, and the flexible contracting member is disposed alongside the
longitudinal member externally to the outer surface thereof, and

reducing the perimeter of the longitudinal member comprises:

- 15 applying a pulling force to the contracting wire, and
 responsively to the applying the pulling force, facilitating sliding of the
first end of the longitudinal member with respect to the second end in the first
direction.

FIG. 1

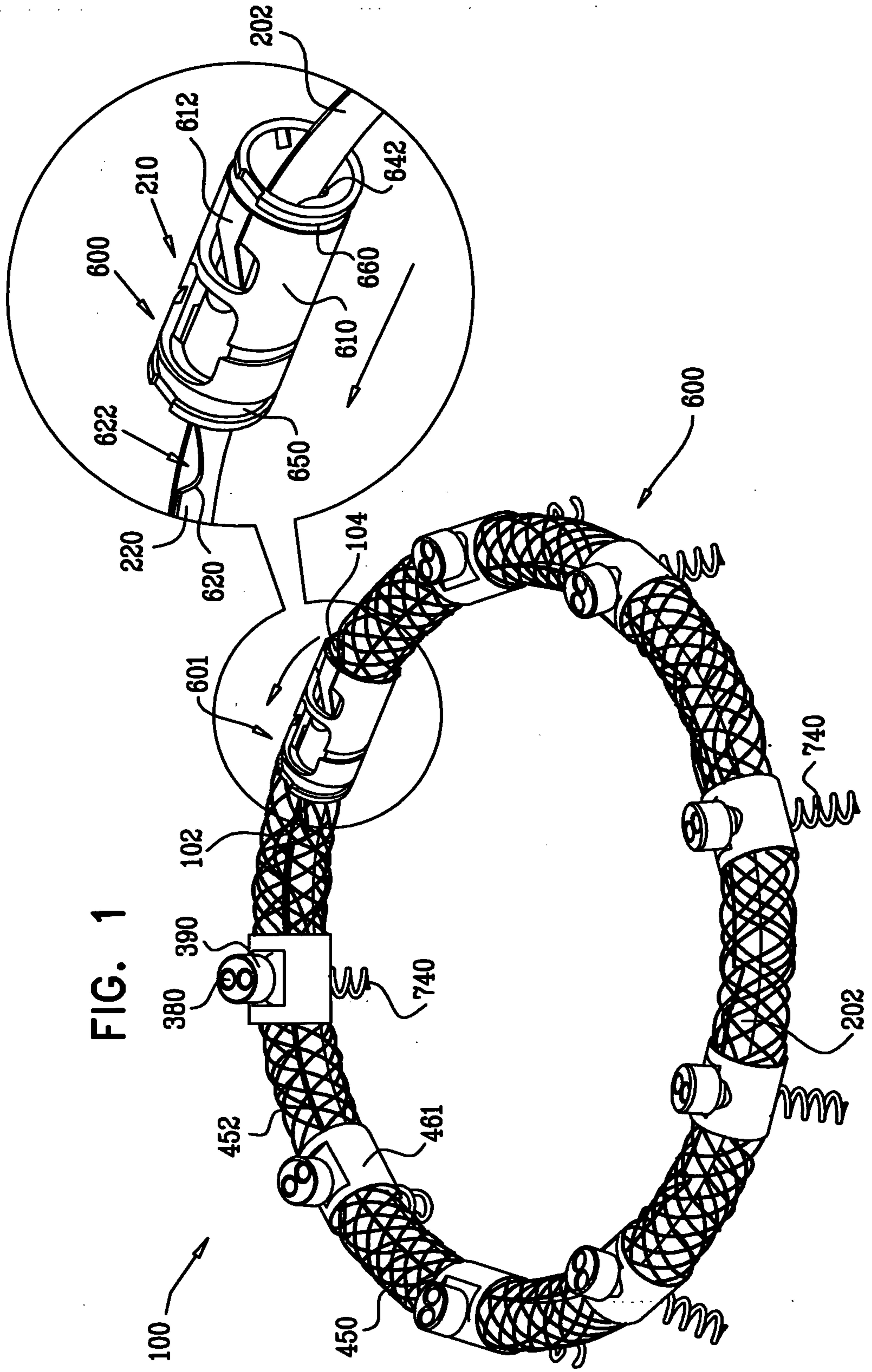

2/28

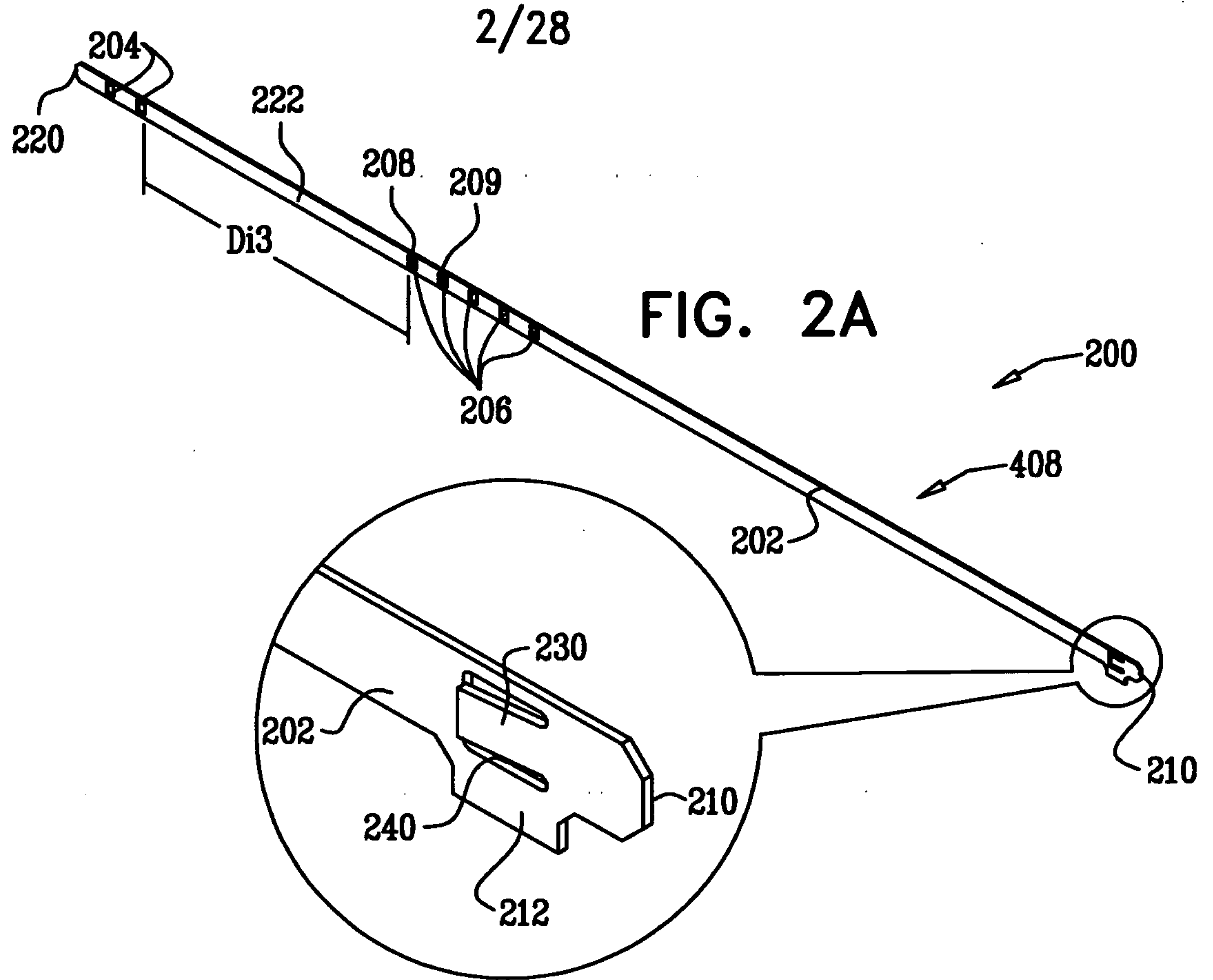

FIG. 2A

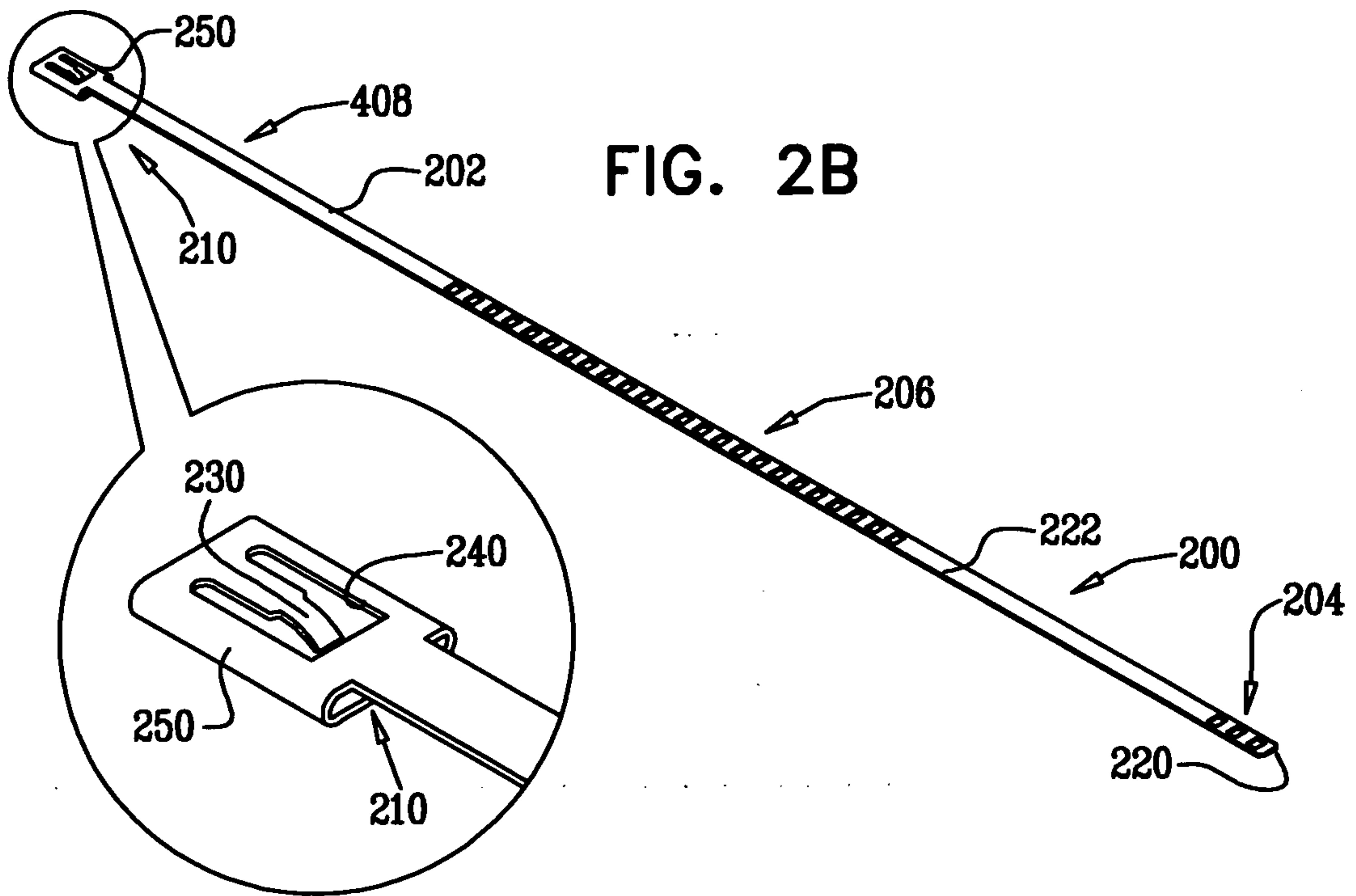
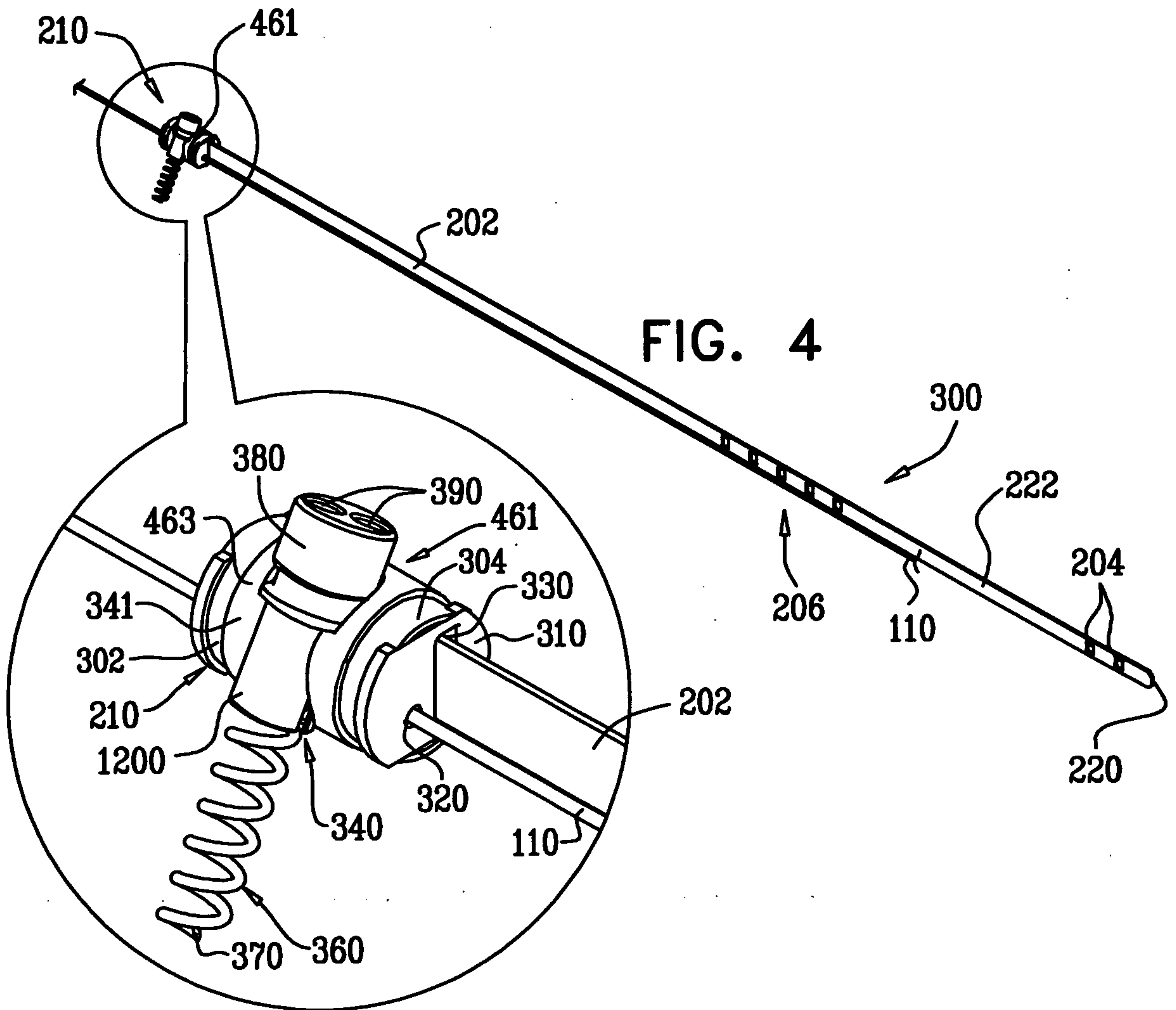
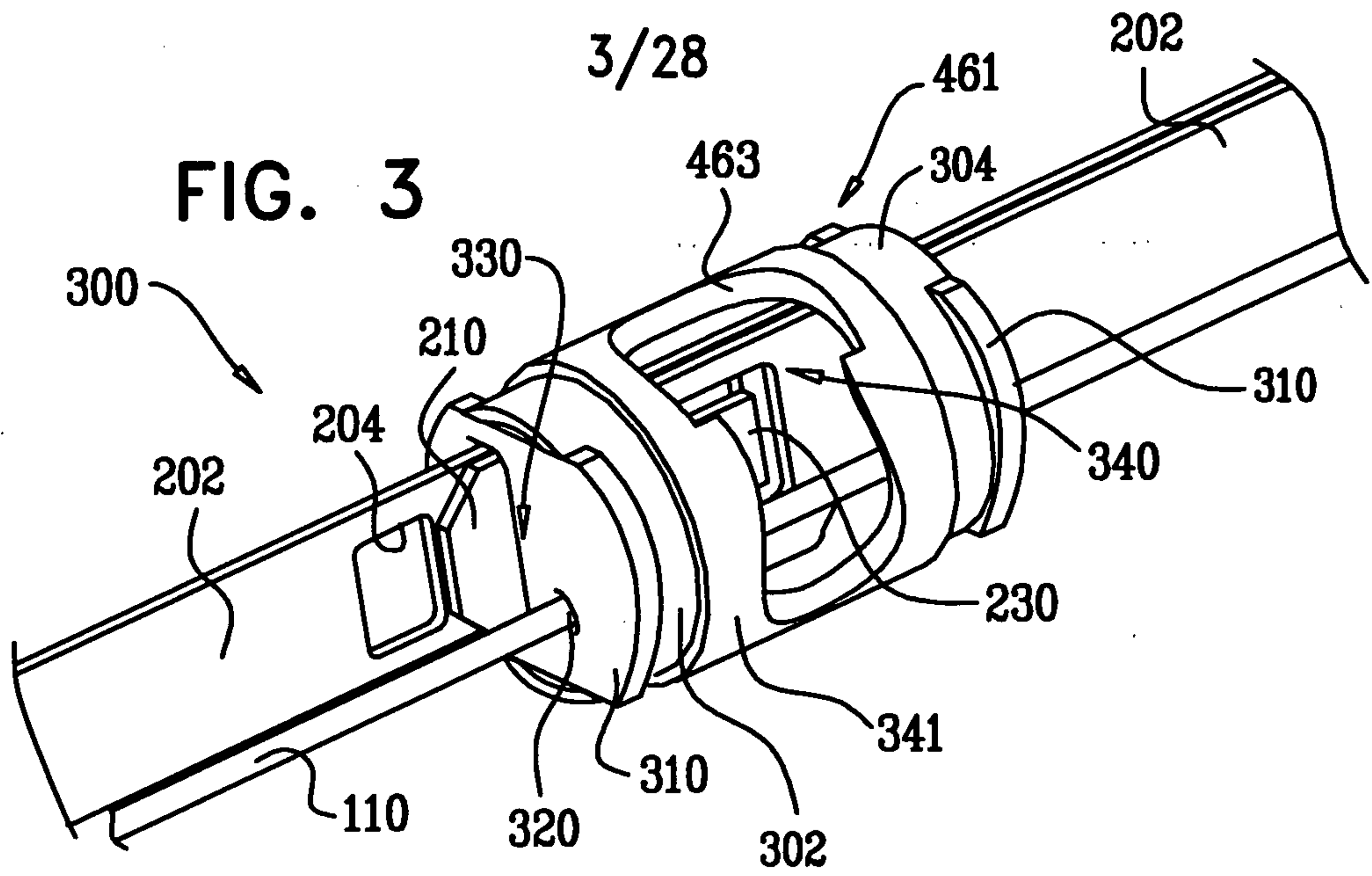

FIG. 2B



4/28

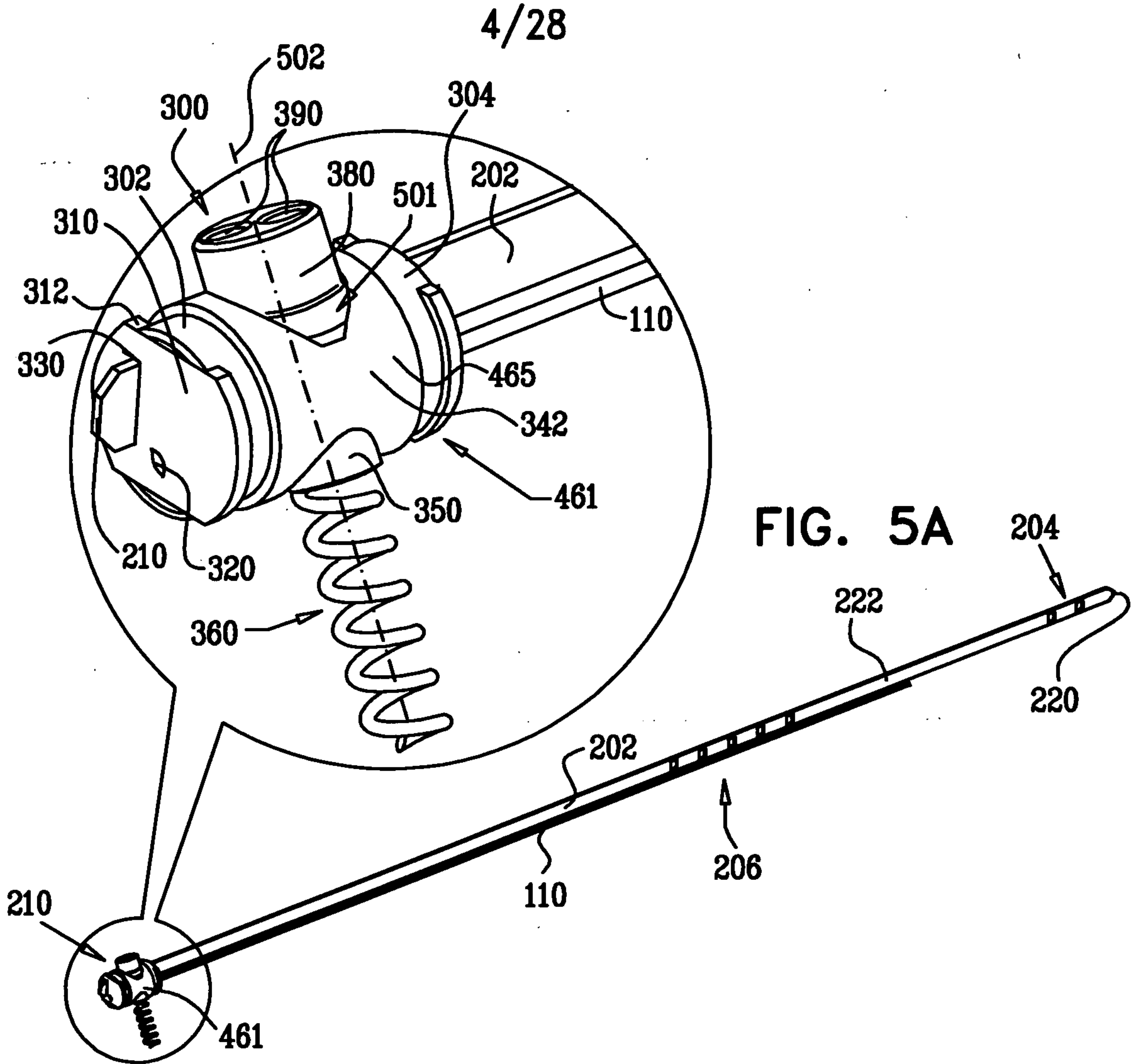

FIG. 5A

FIG. 5C

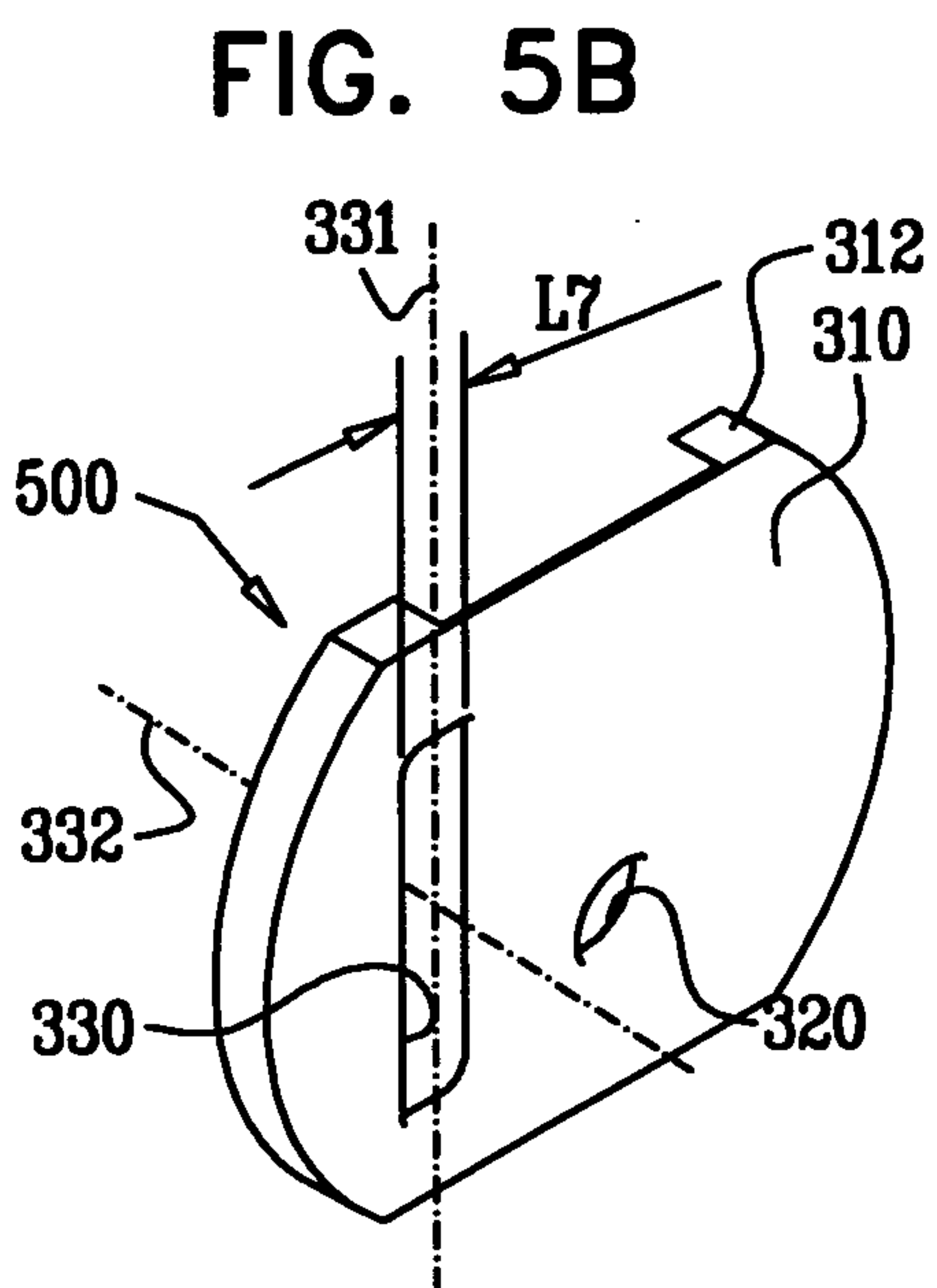
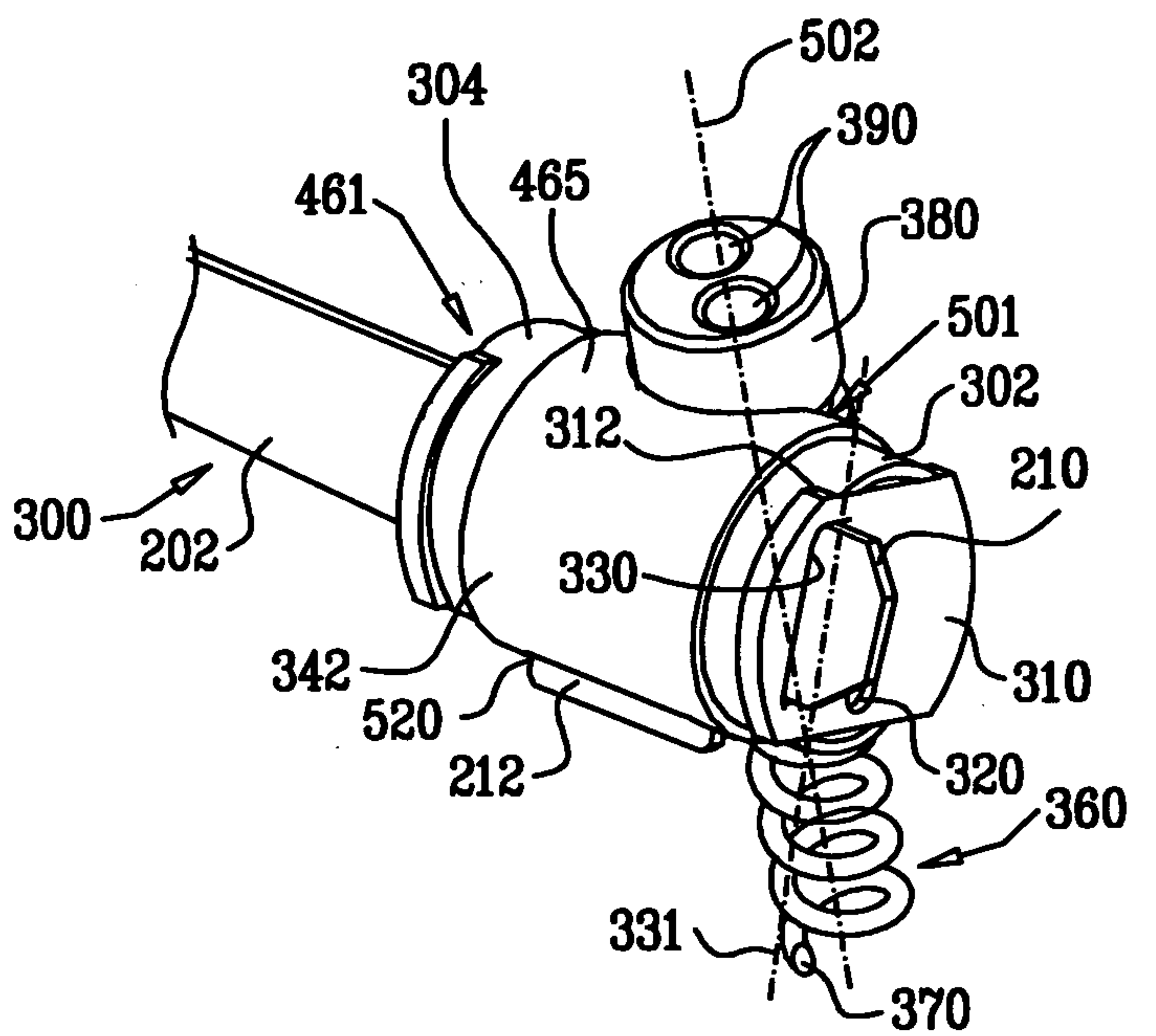

FIG. 5B



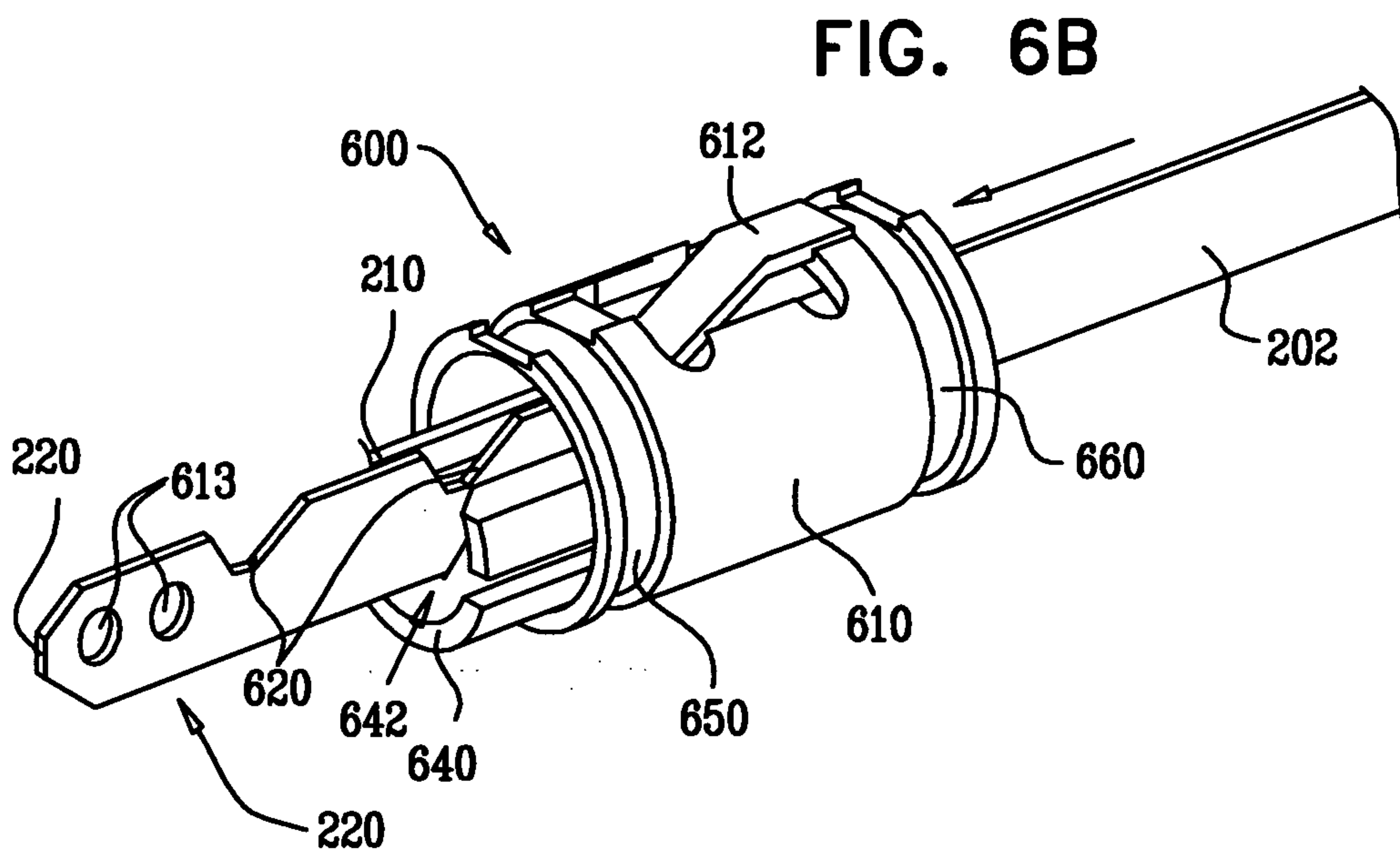
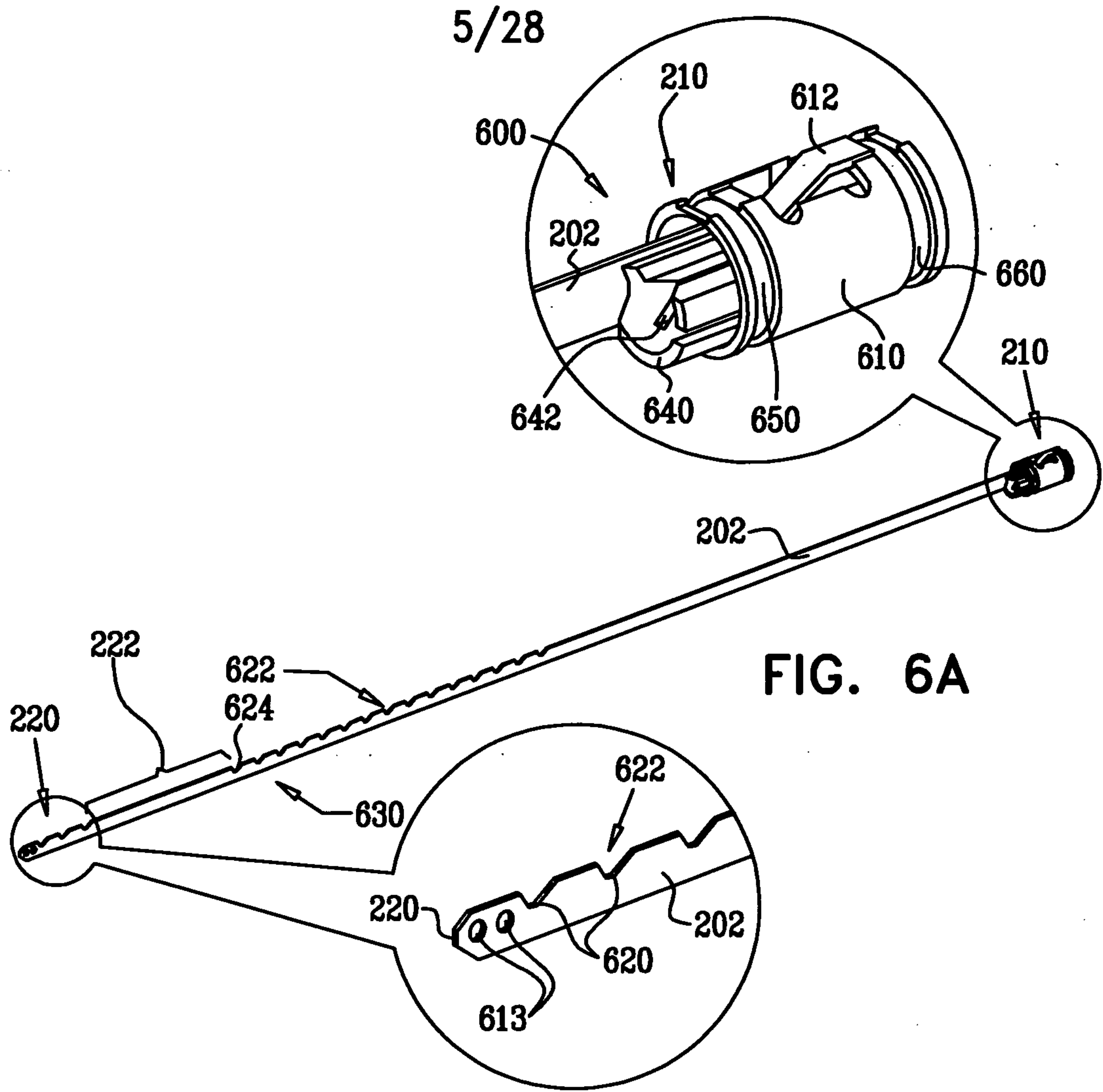

FIG. 7

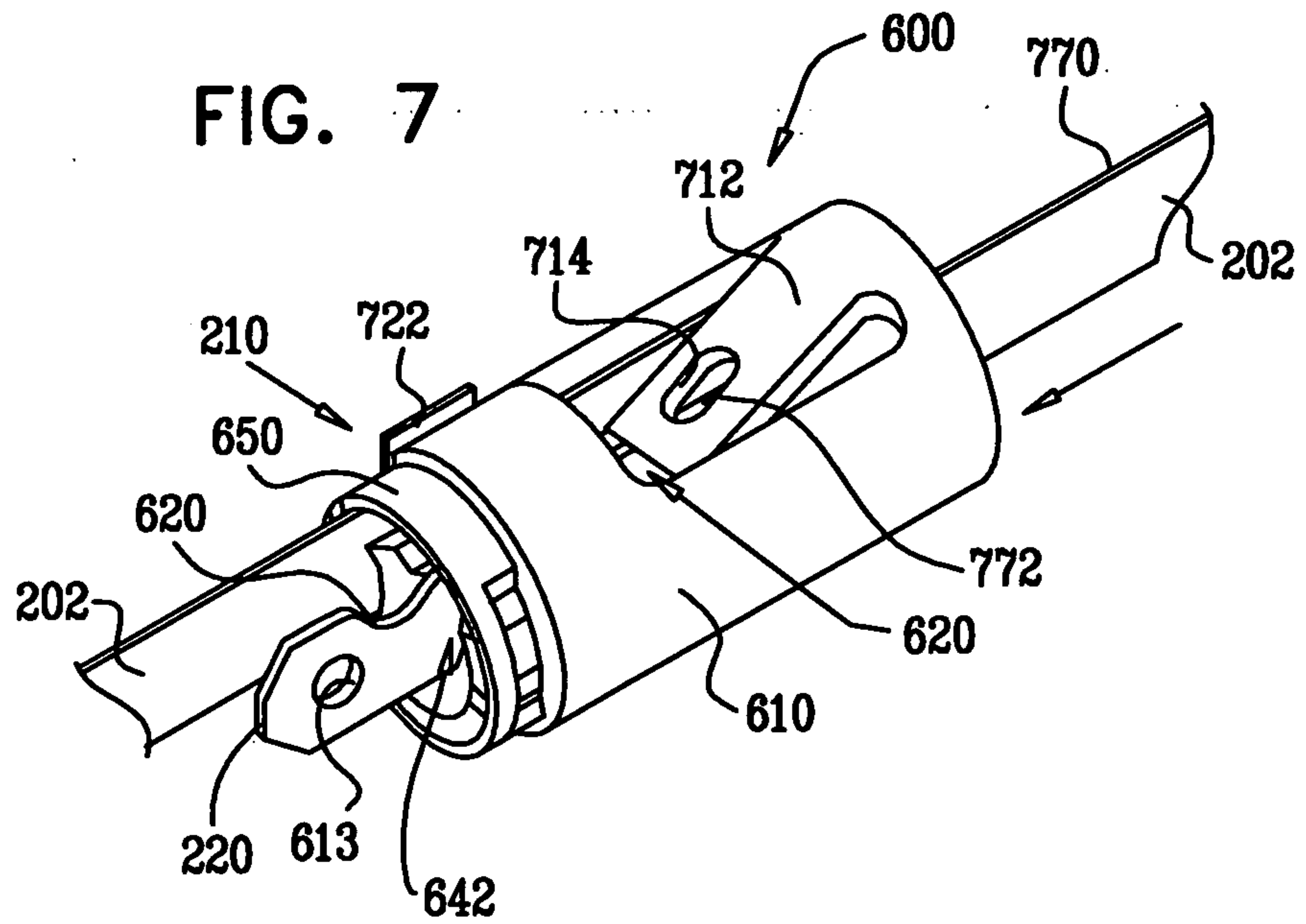

FIG. 8

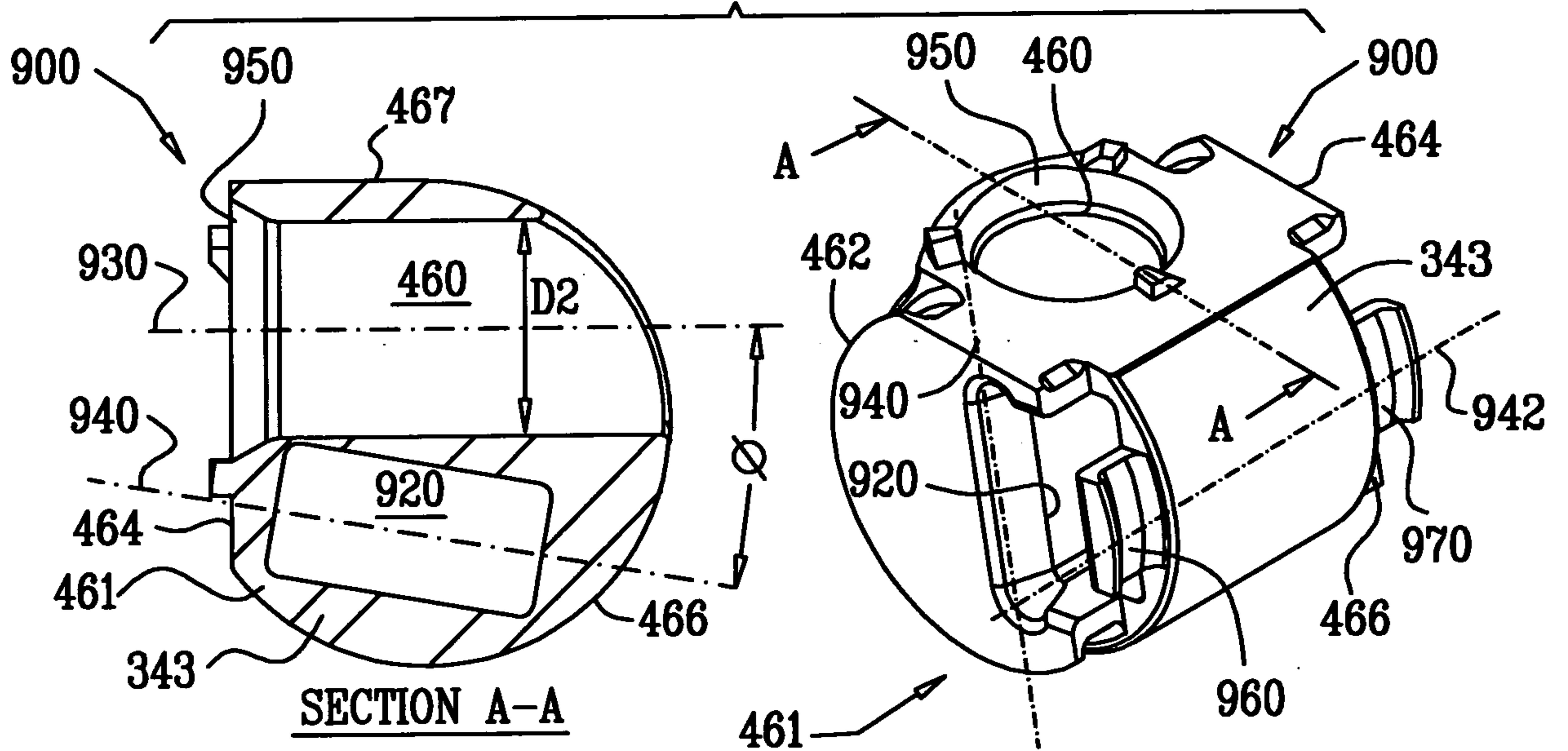

FIG. 9

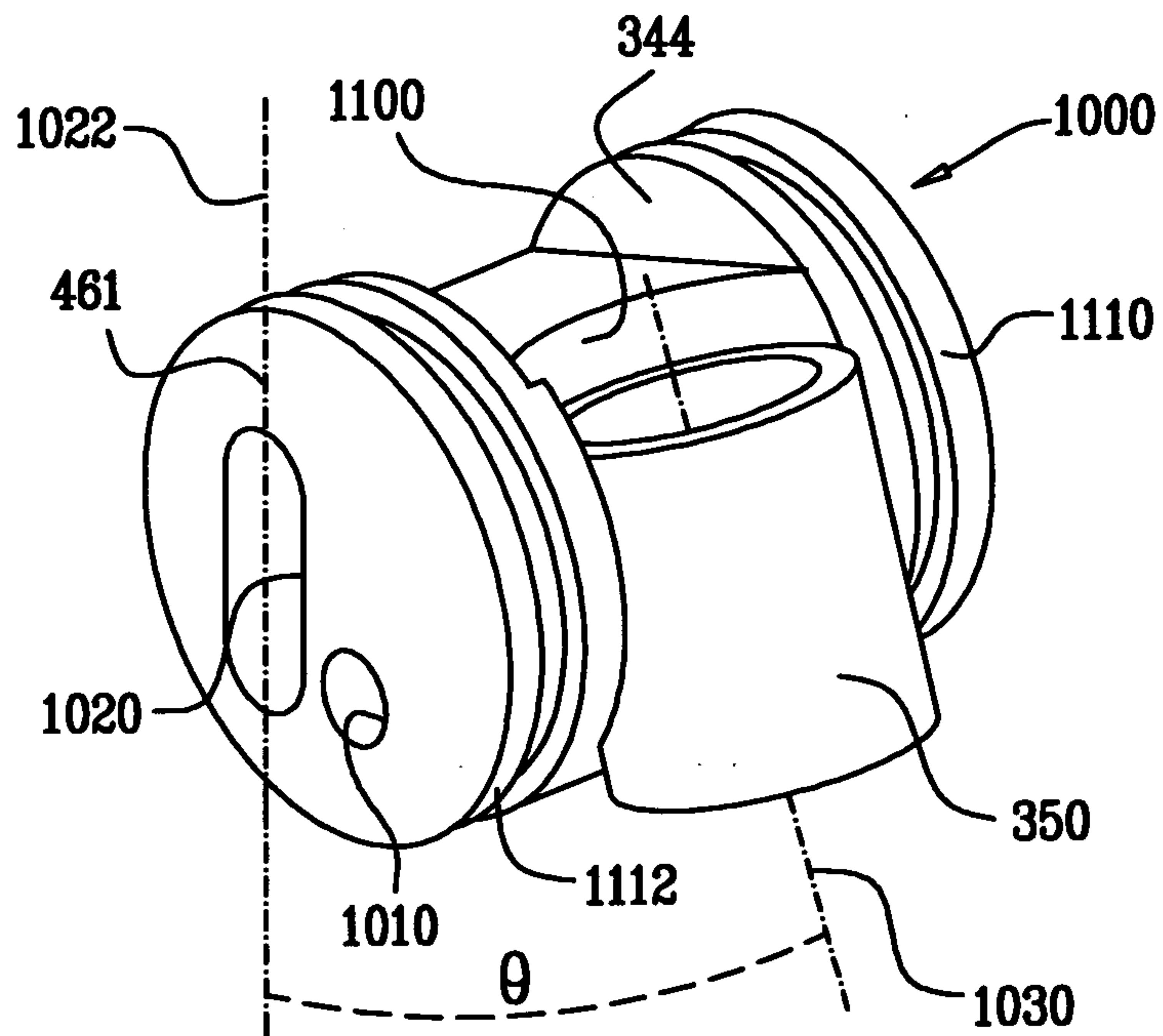
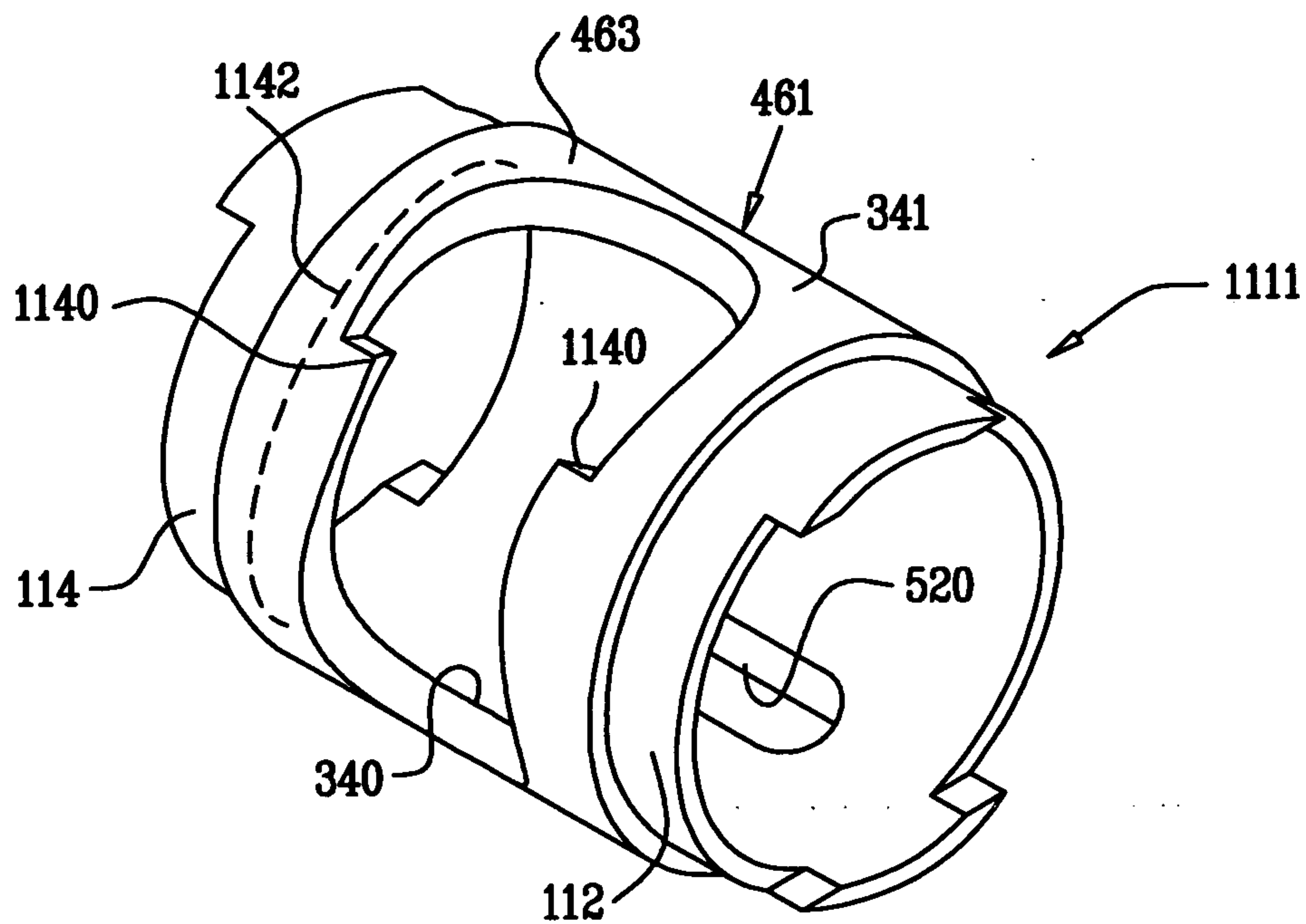

FIG. 10



8/28

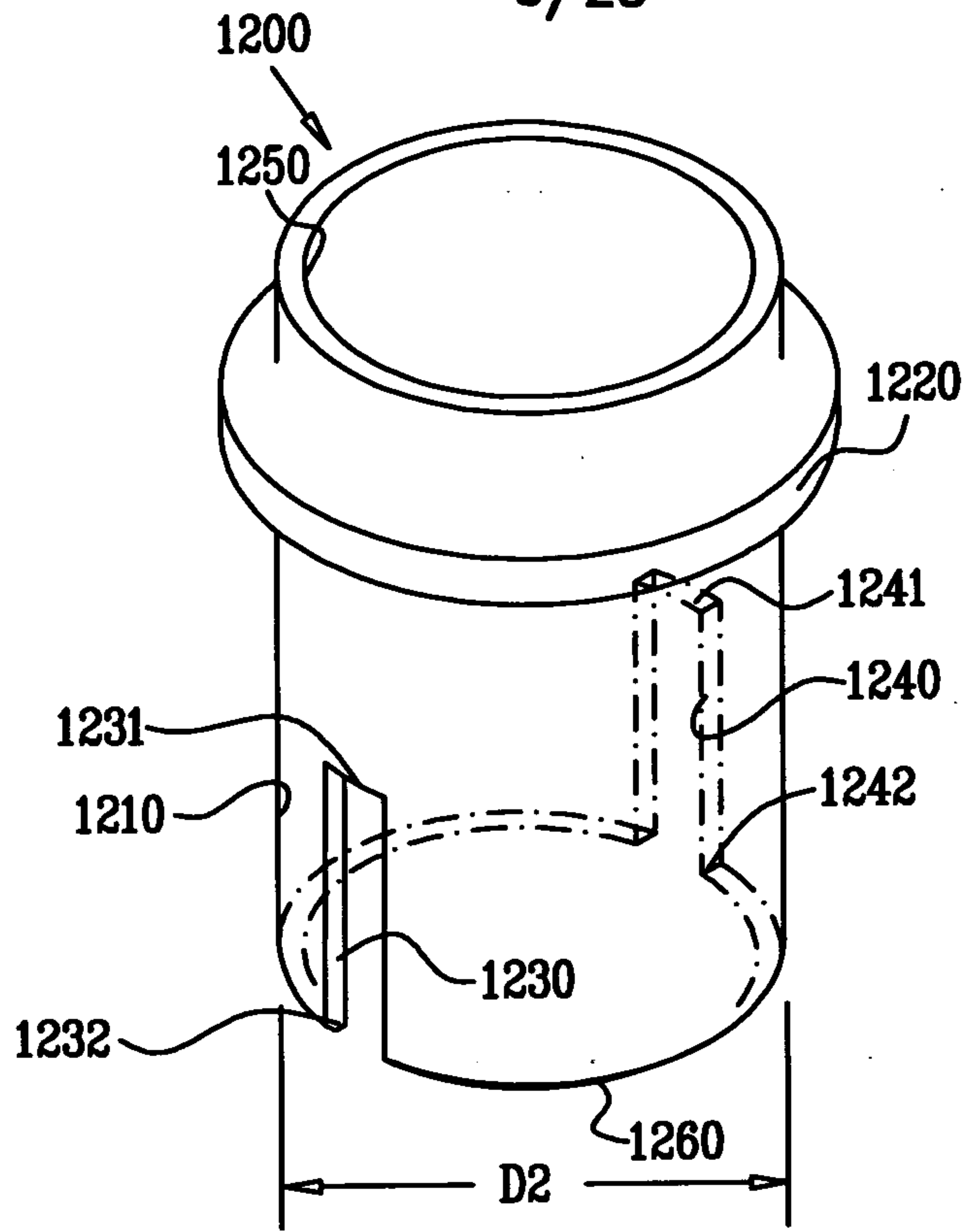
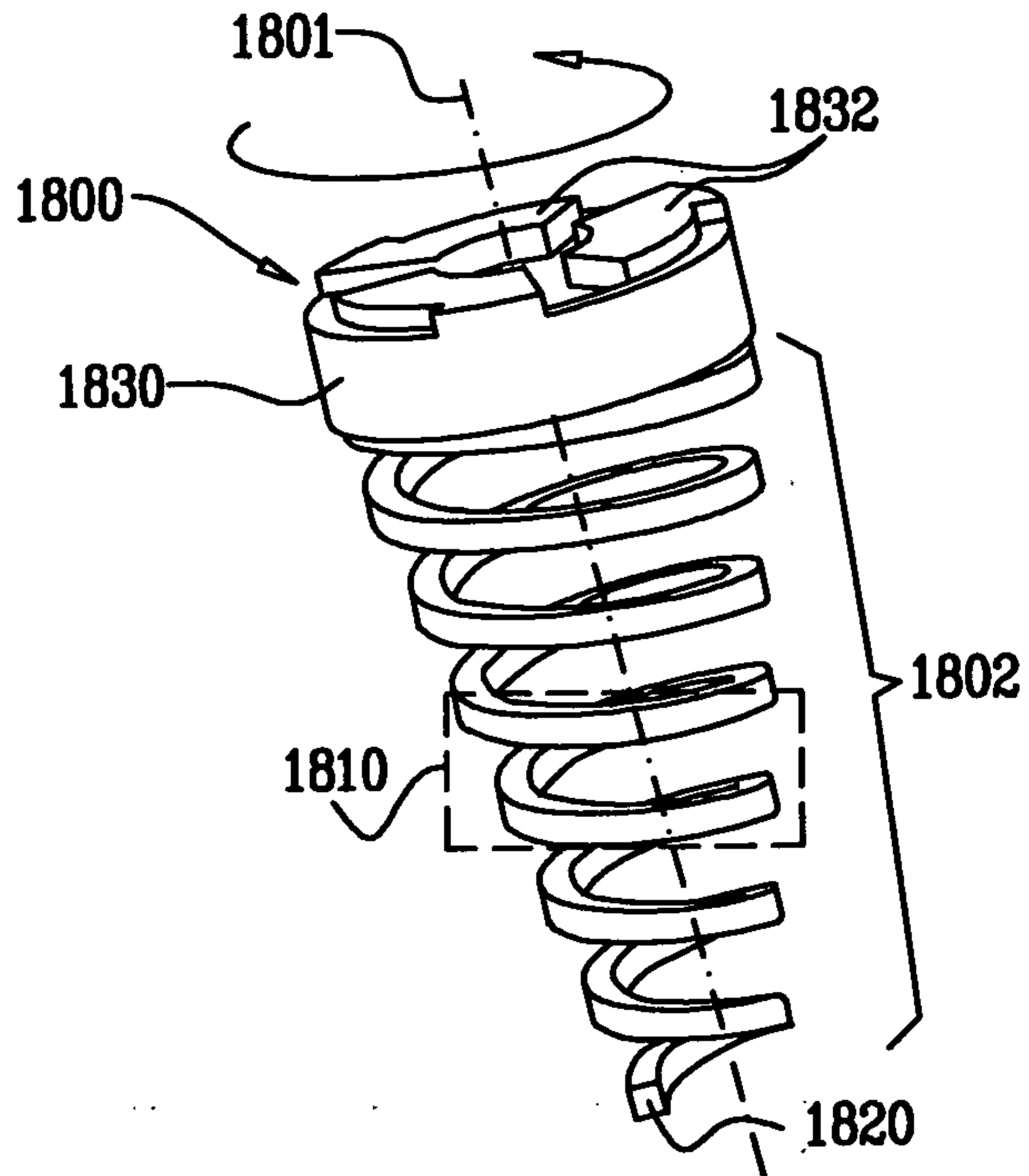

FIG. 11

FIG. 12



9/28

FIG. 13A

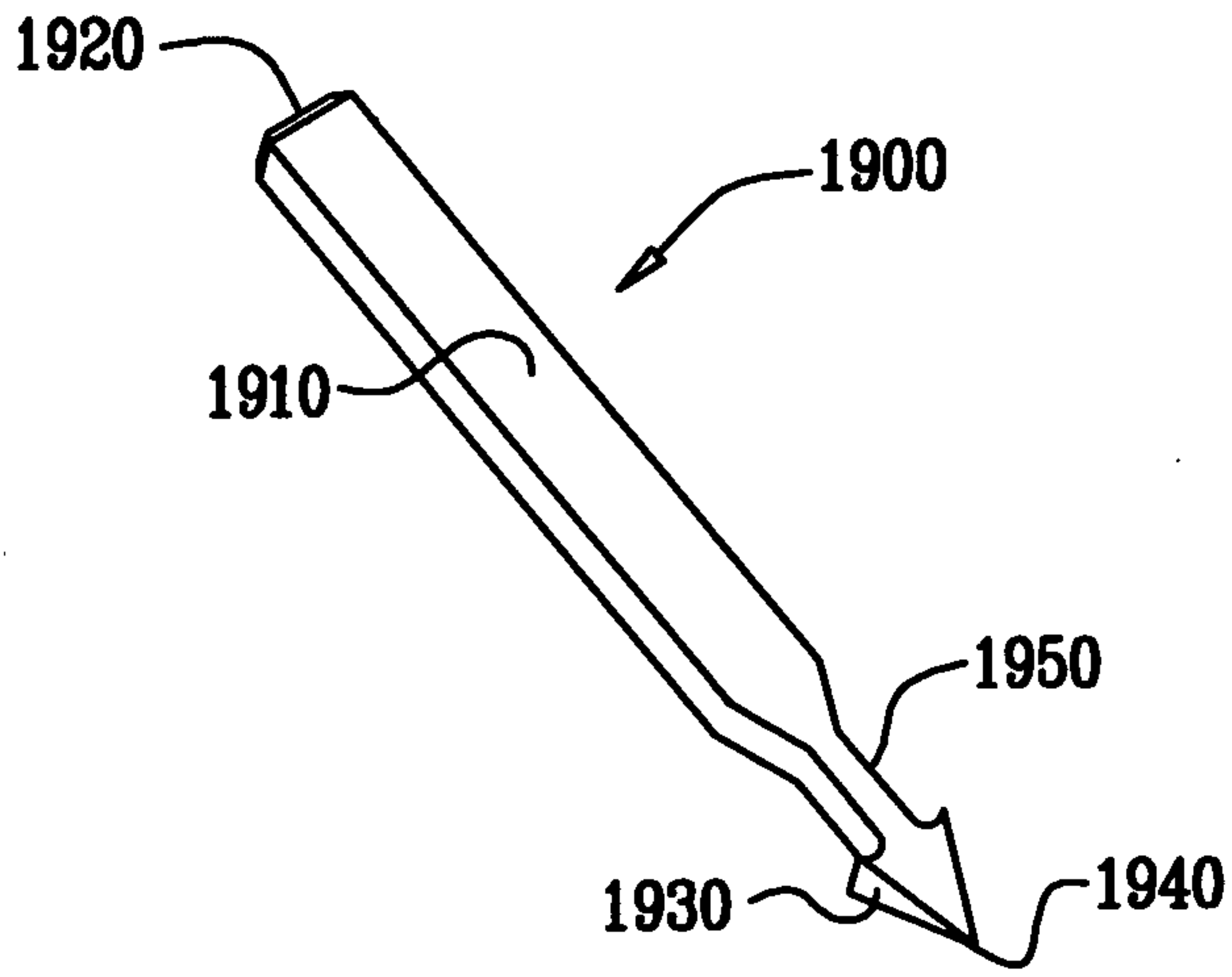

FIG. 13B

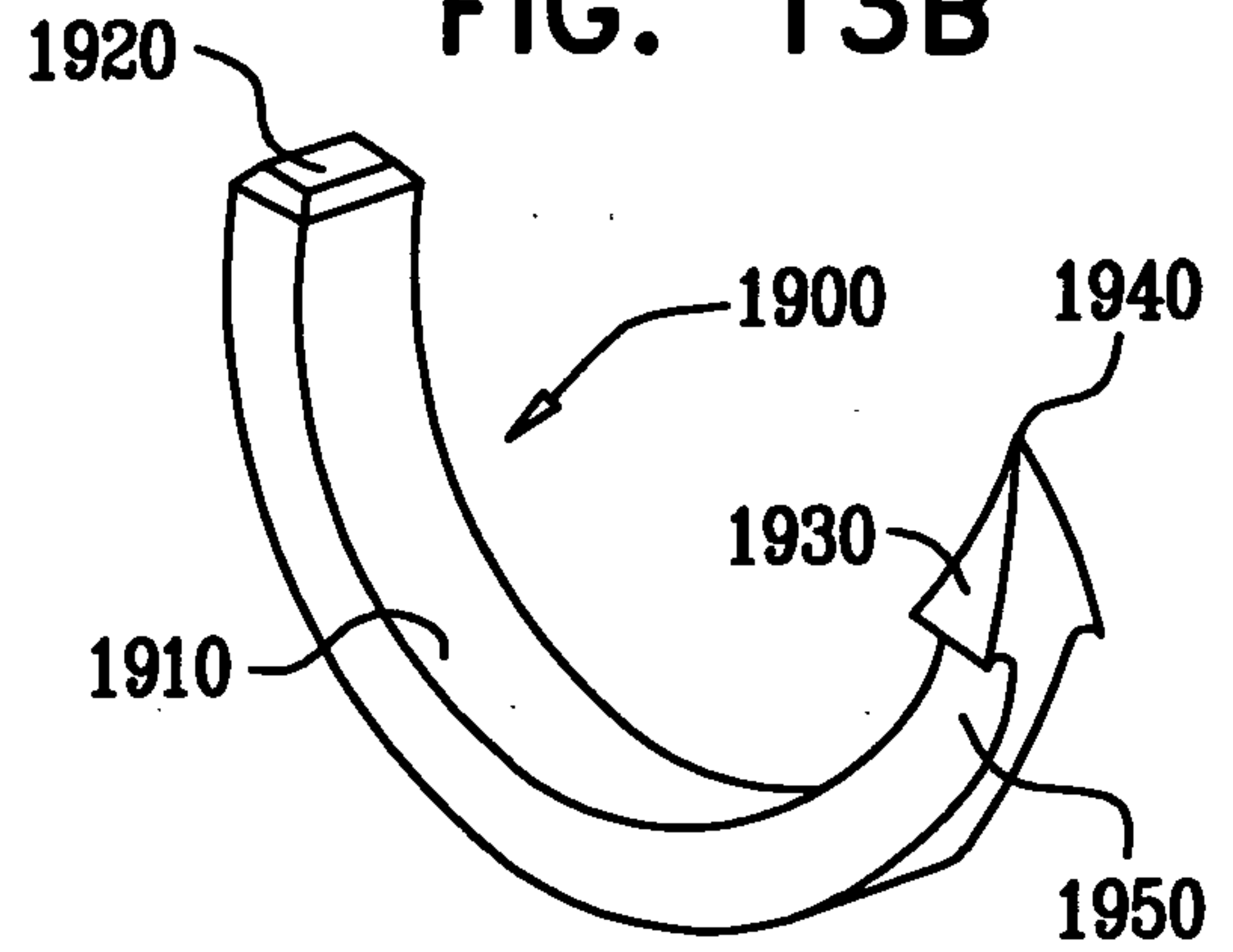

FIG. 13C

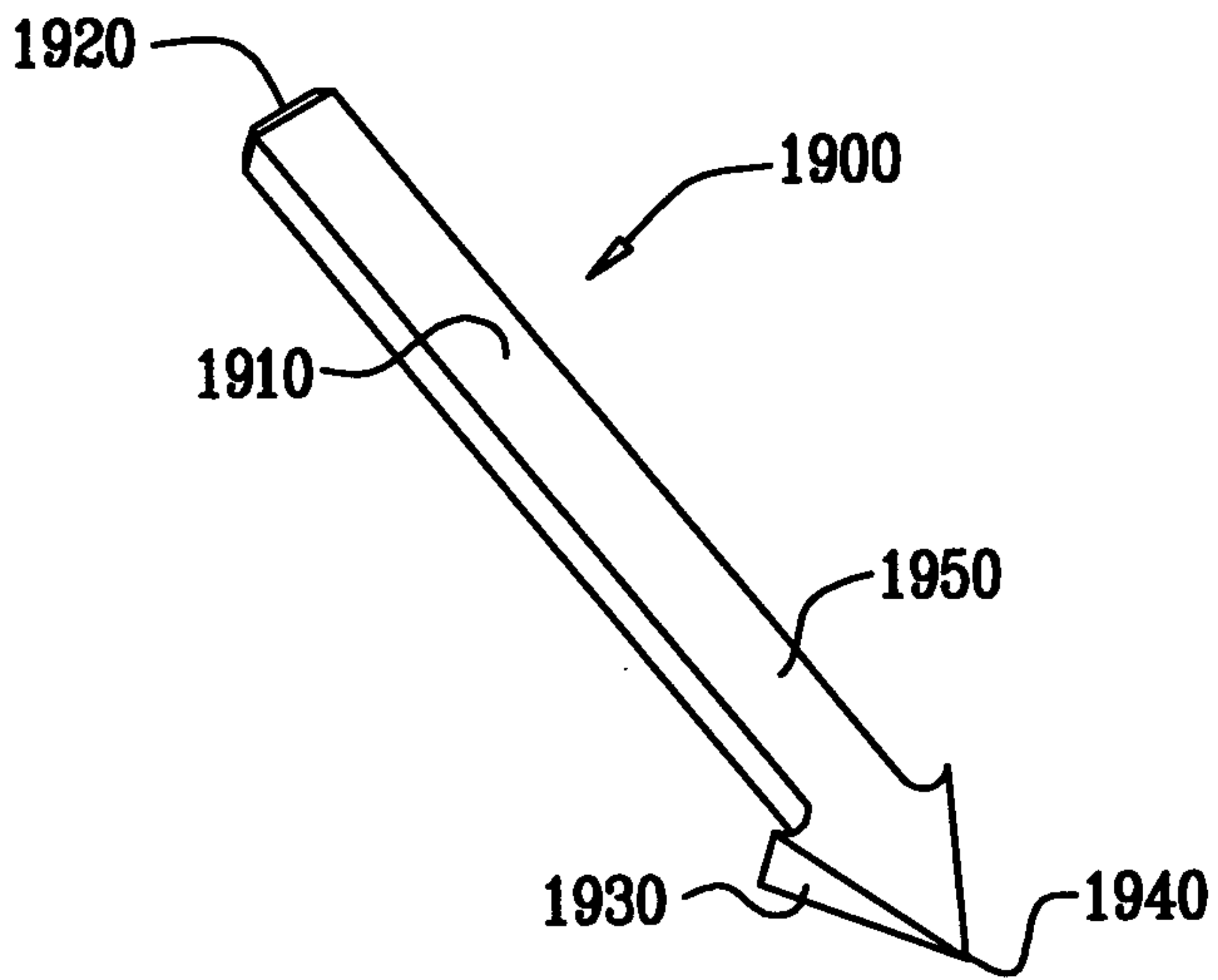

FIG. 13D

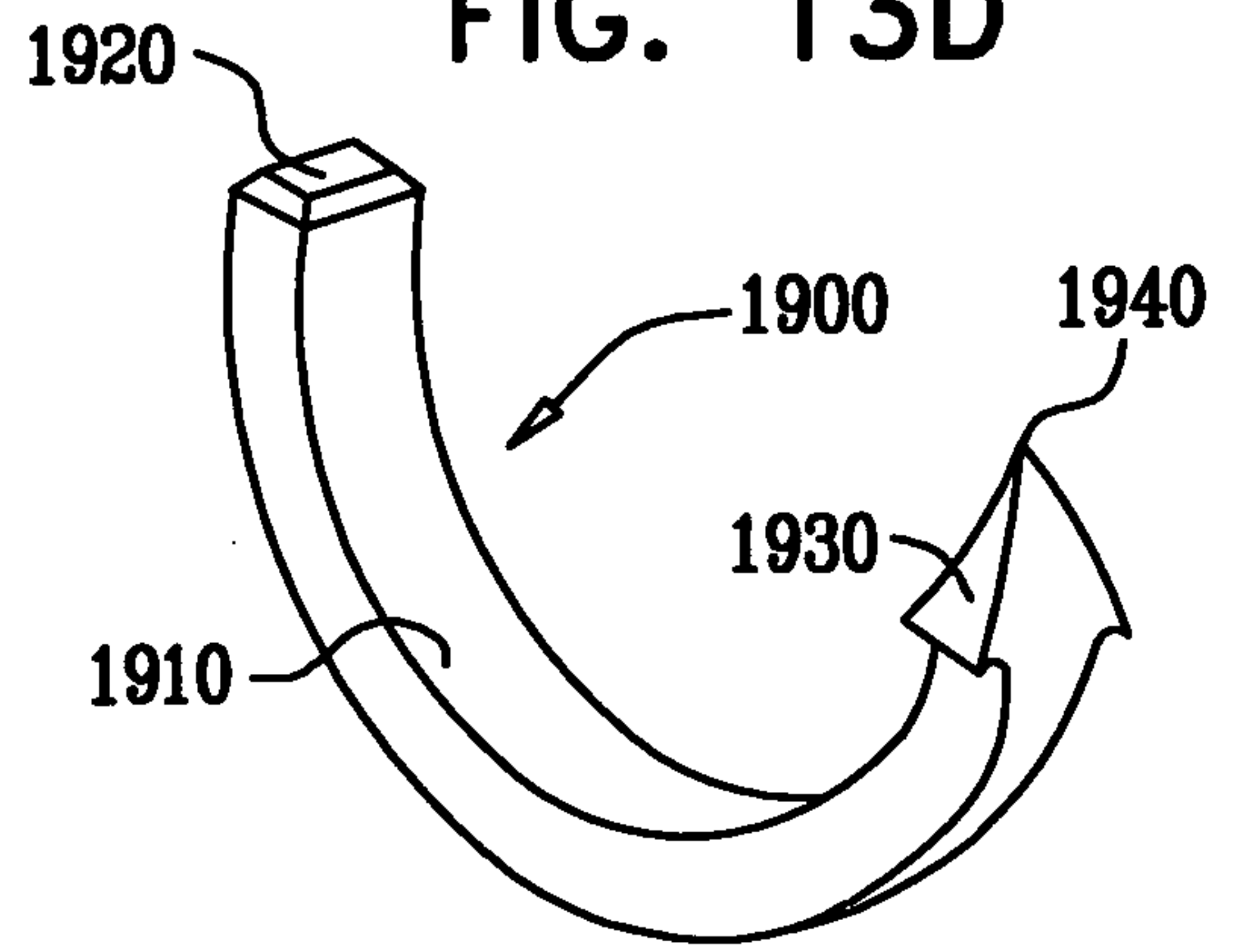
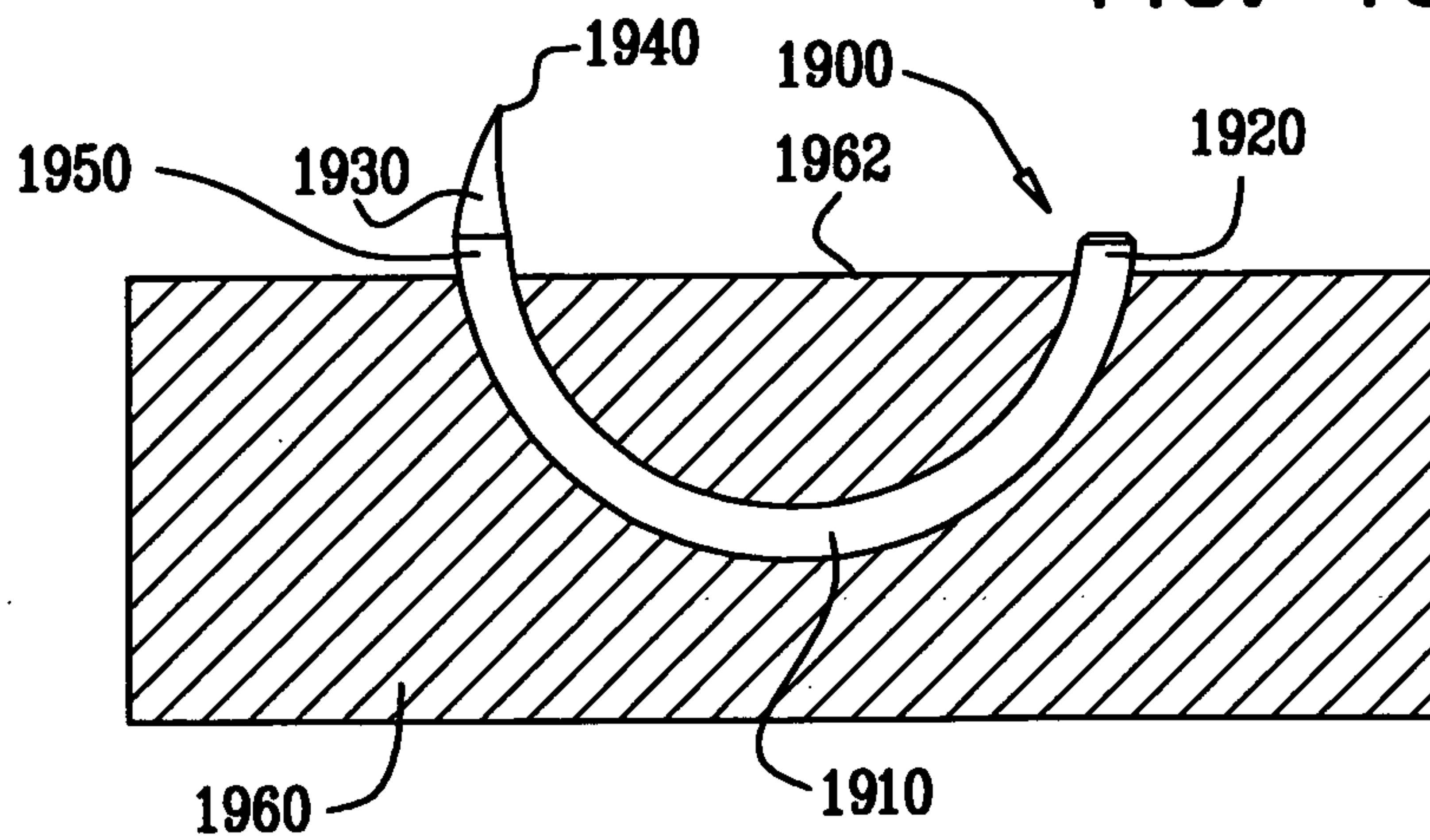

FIG. 13E



10/28

FIG. 14A

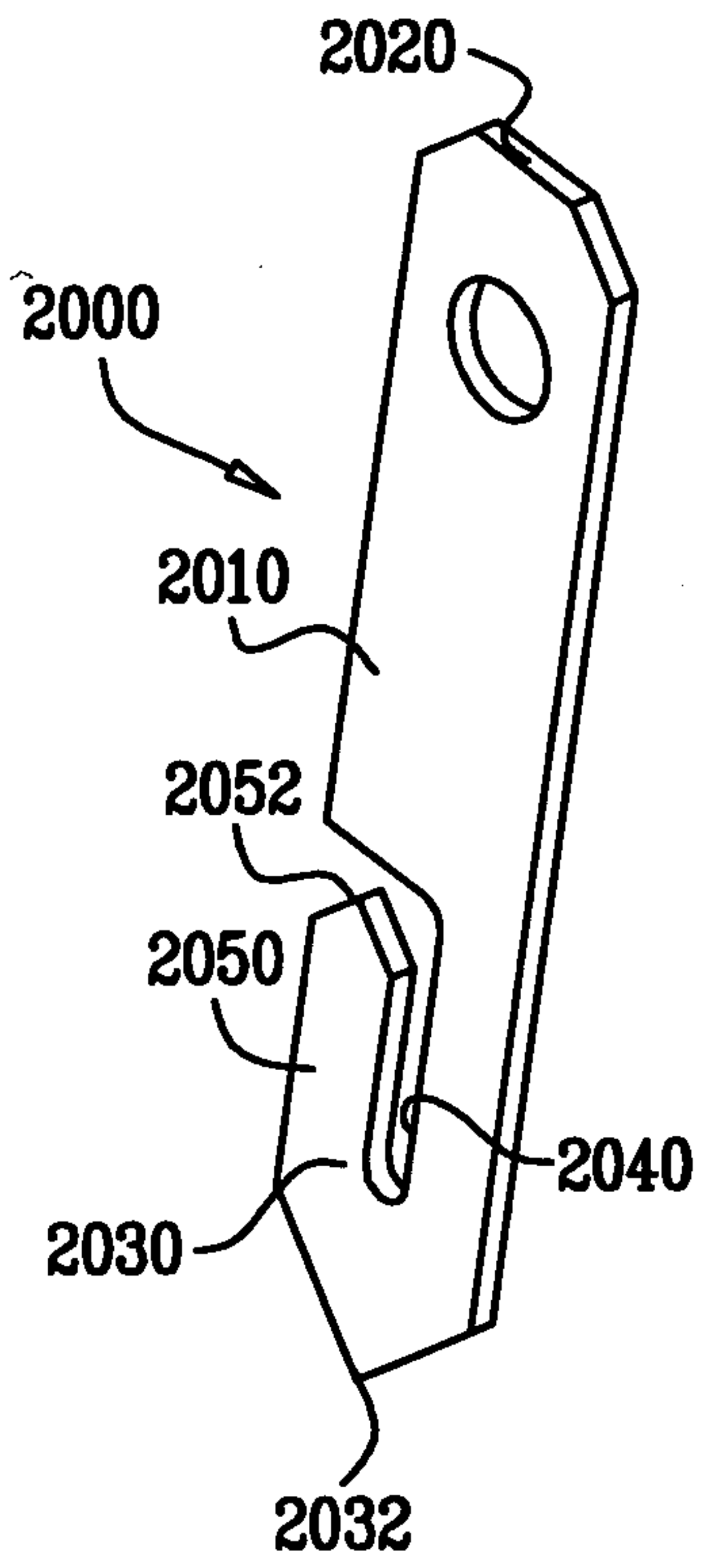

FIG. 14B

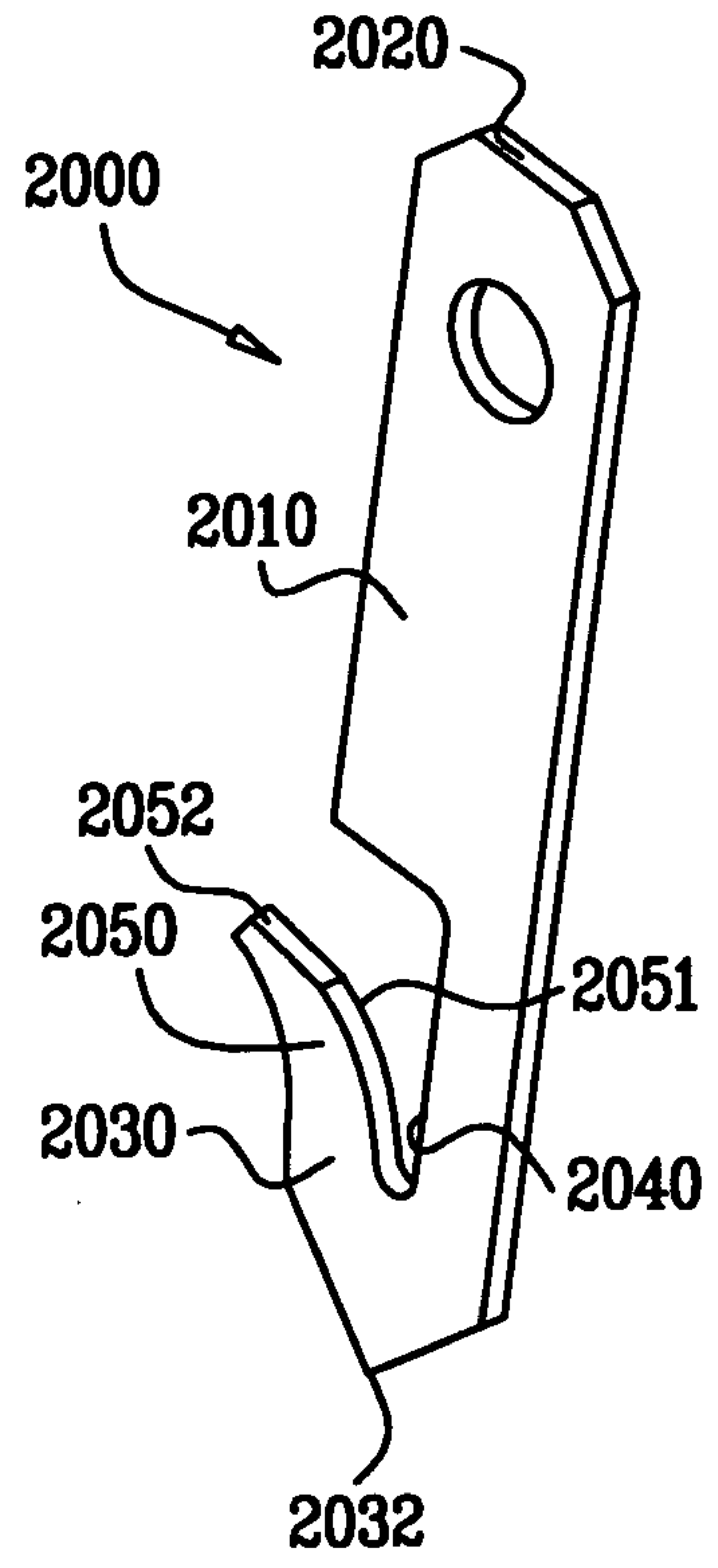
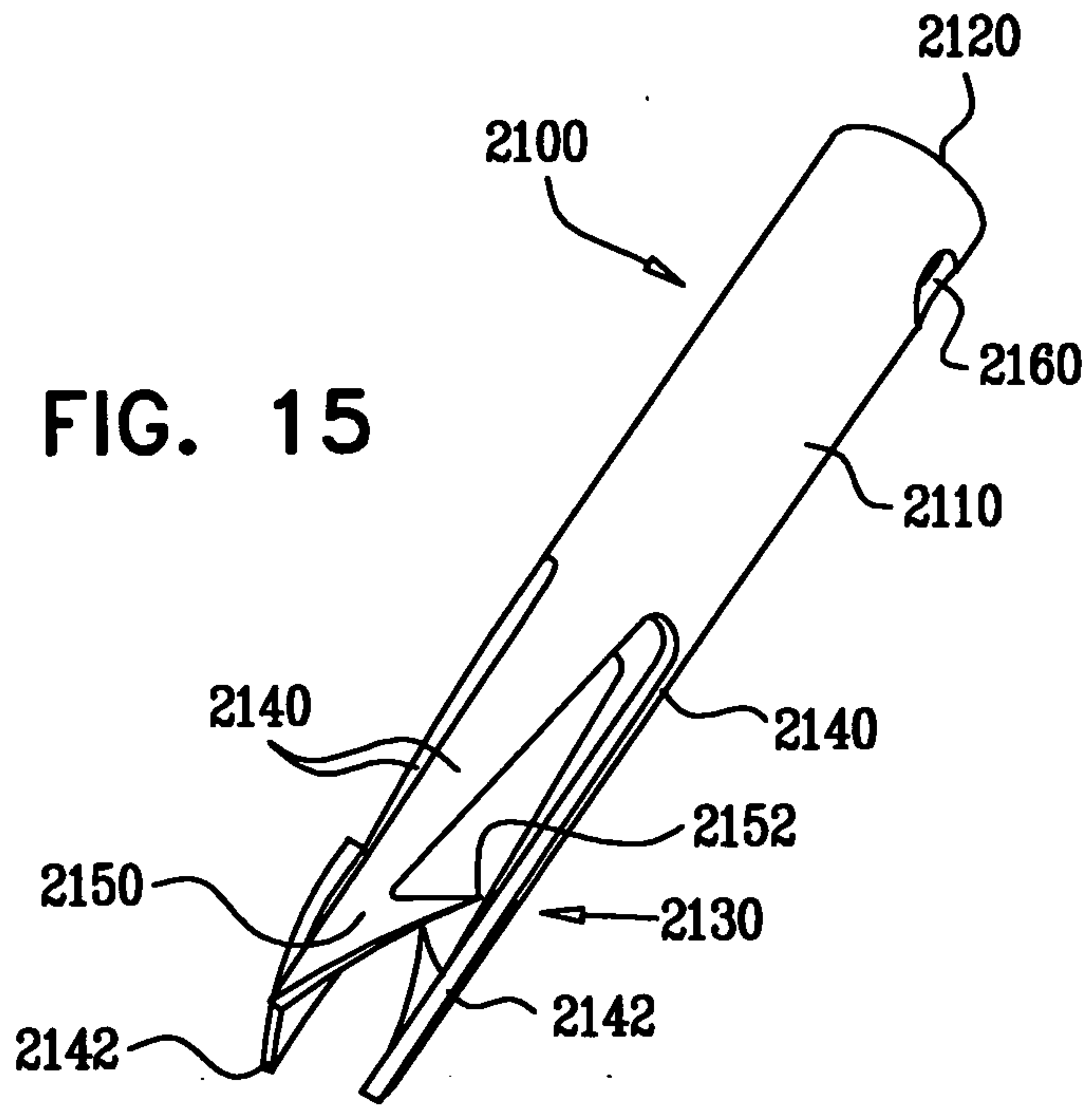

FIG. 15



11/28

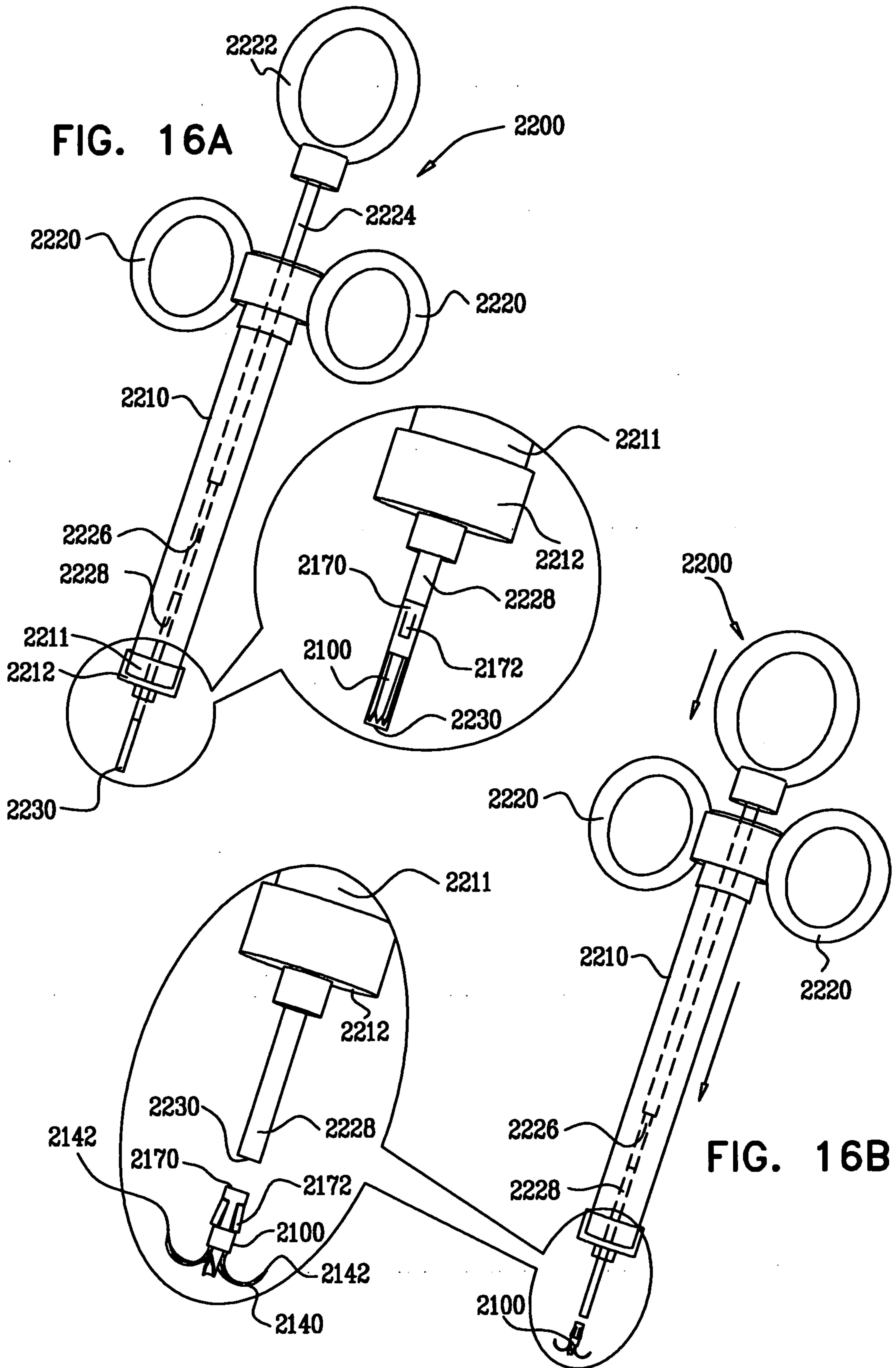

FIG. 16A

FIG. 16B

12/28

FIG. 17A

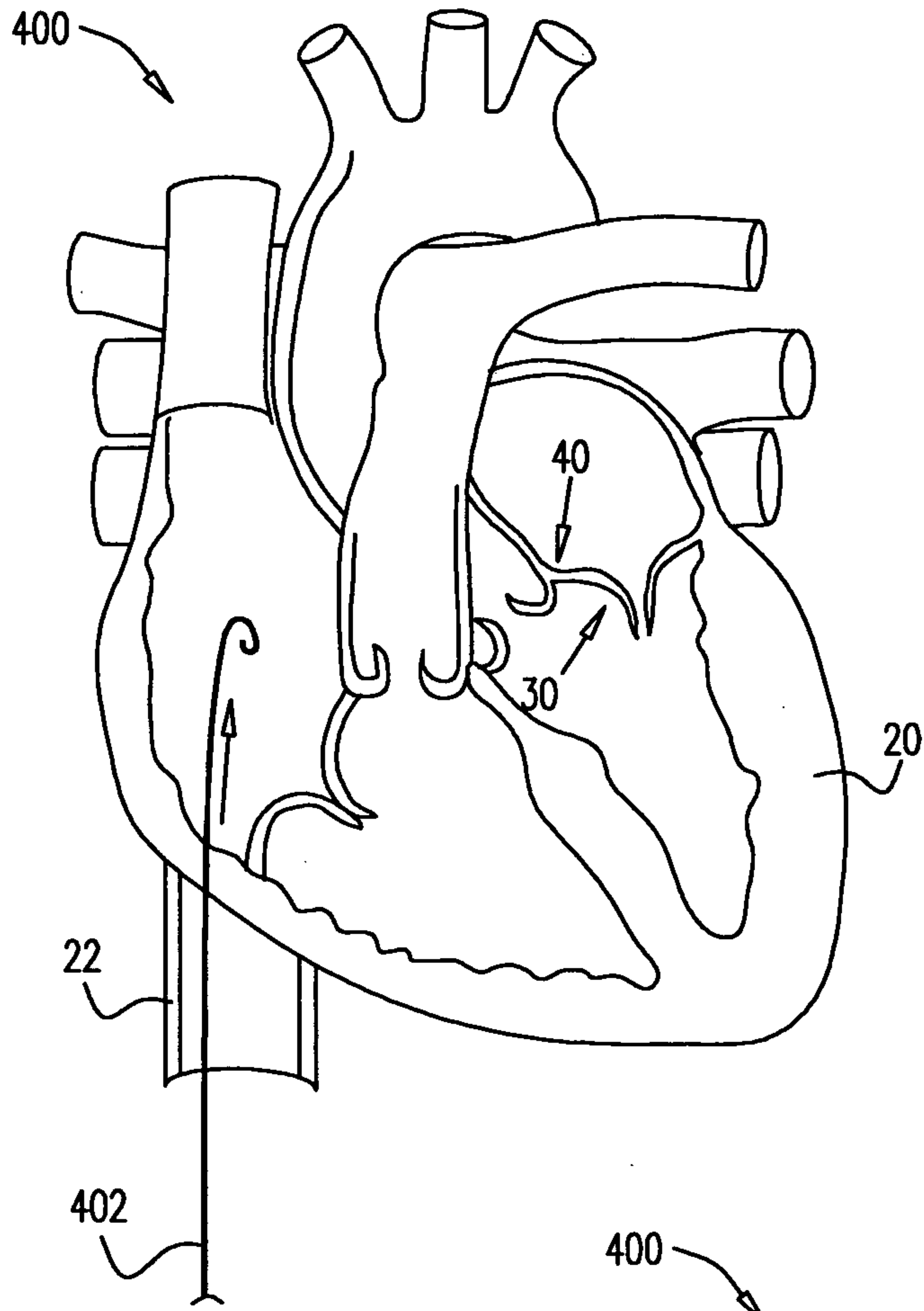

FIG. 17B

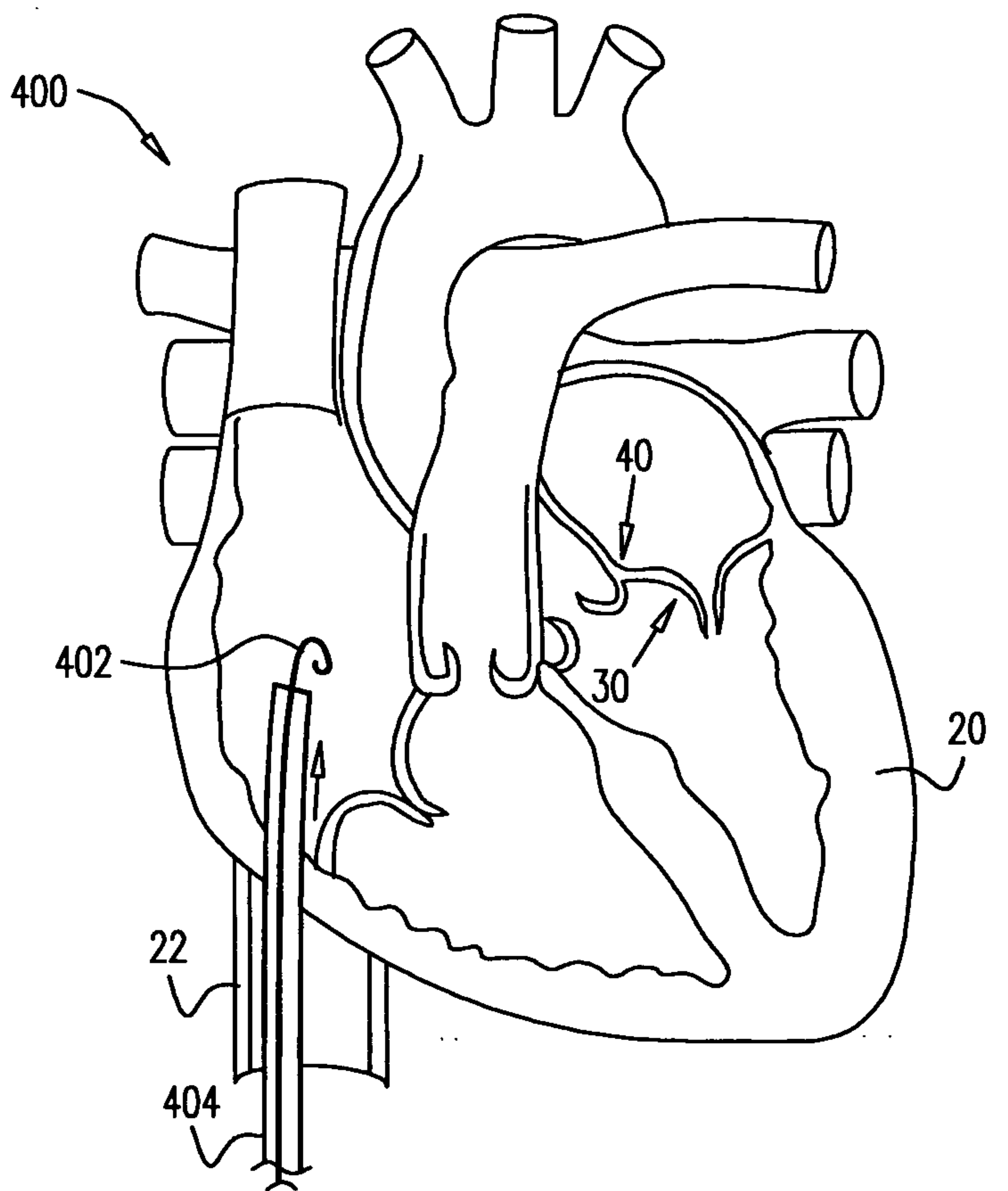

FIG. 17C

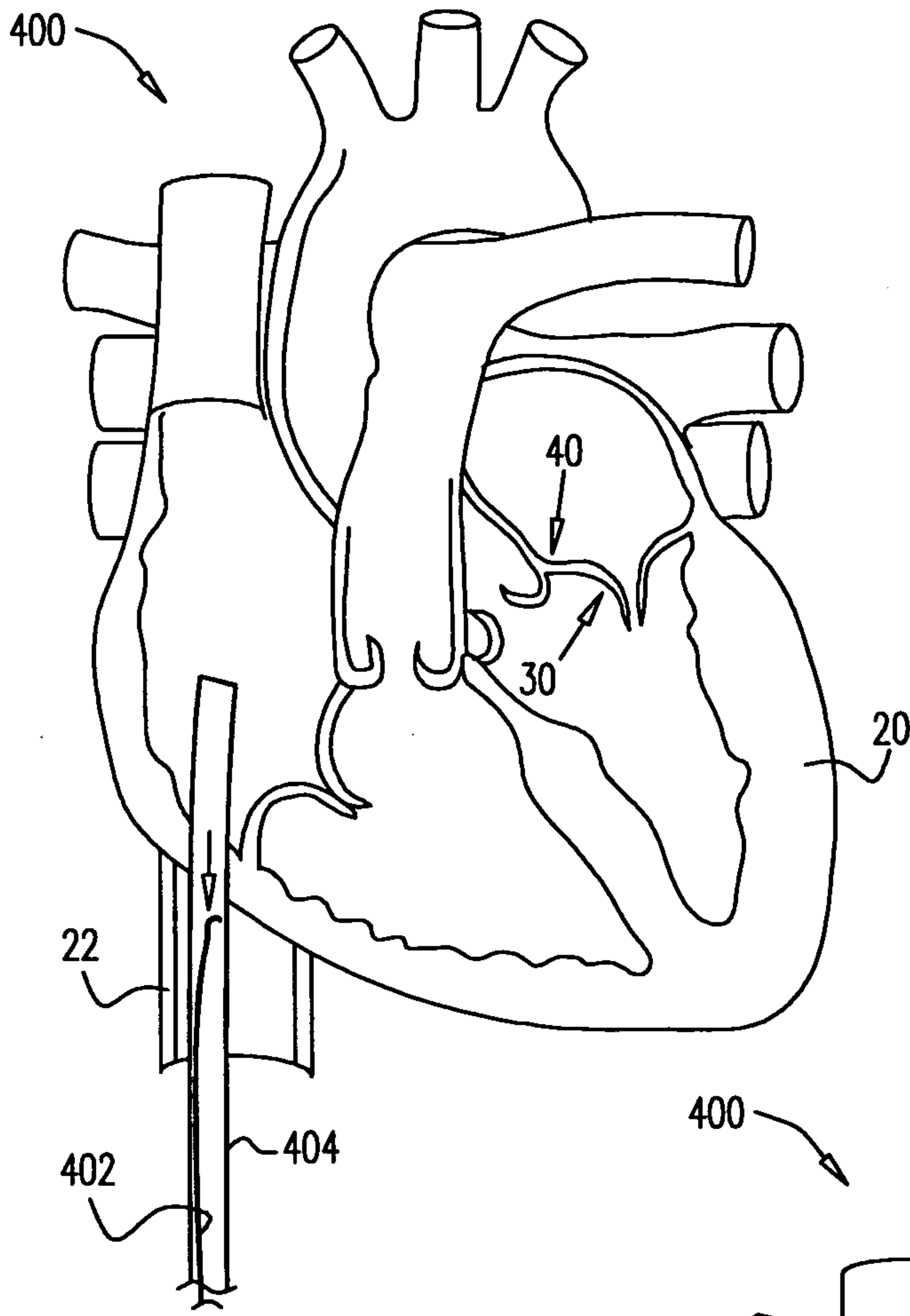

FIG. 17D

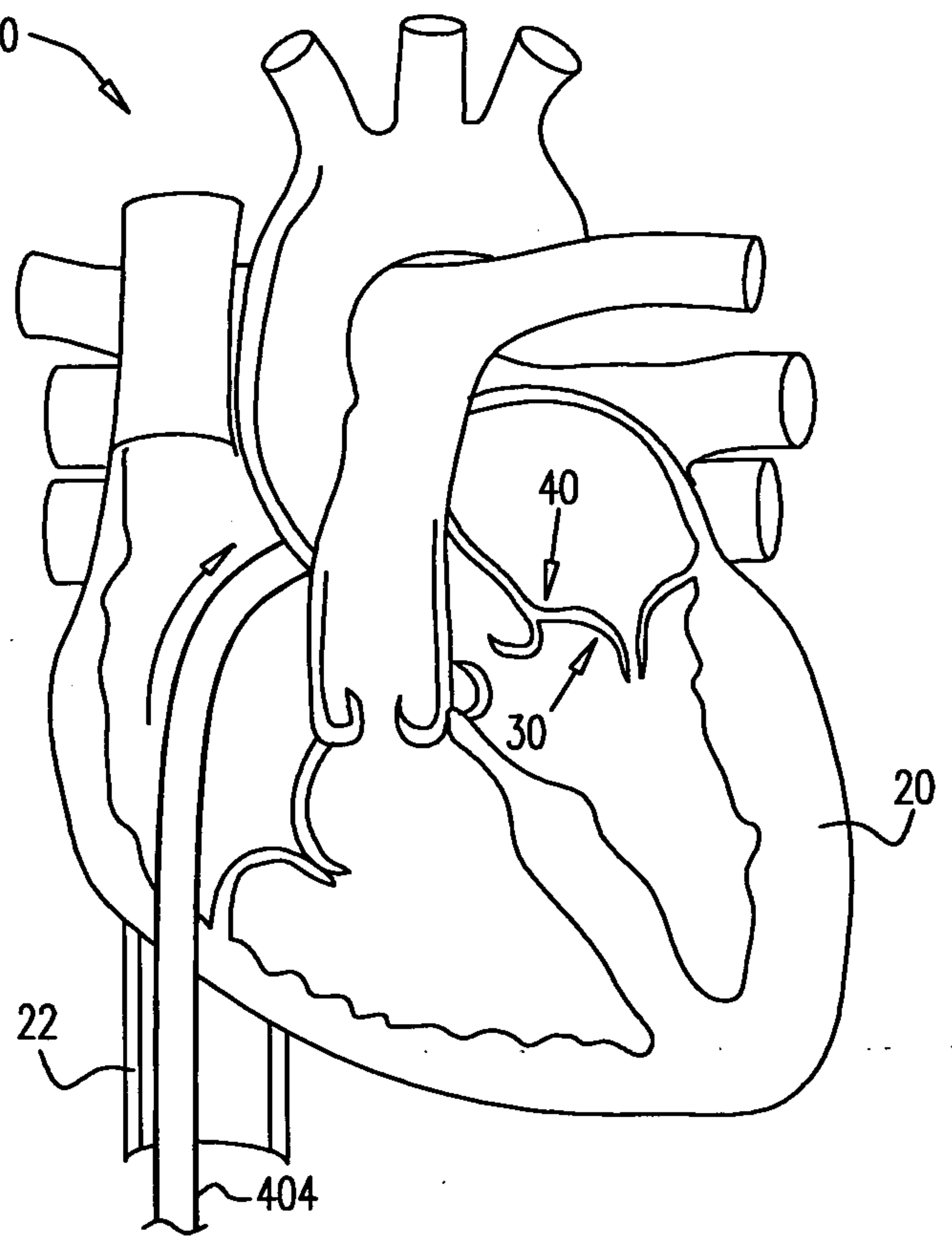

FIG. 17E

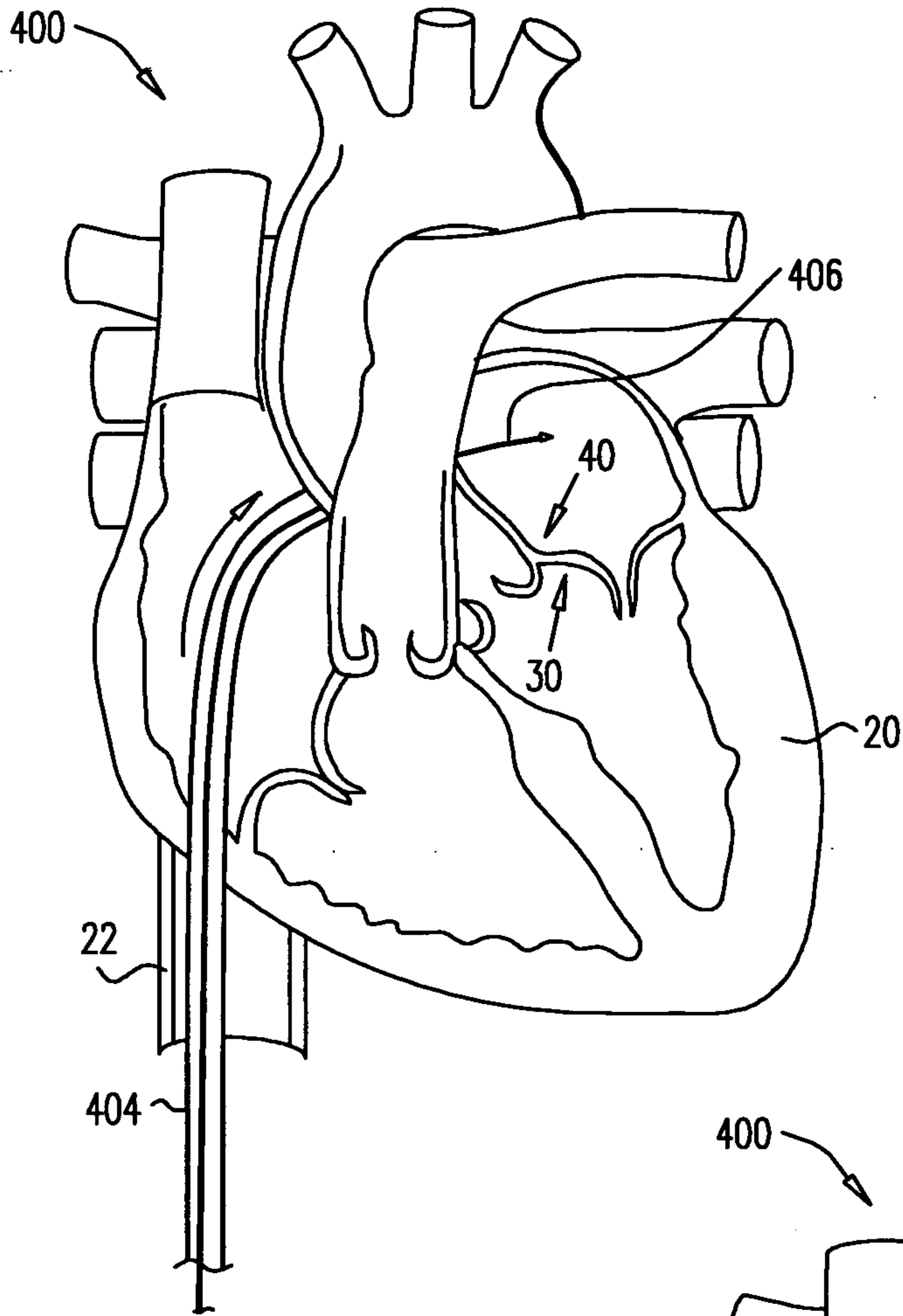
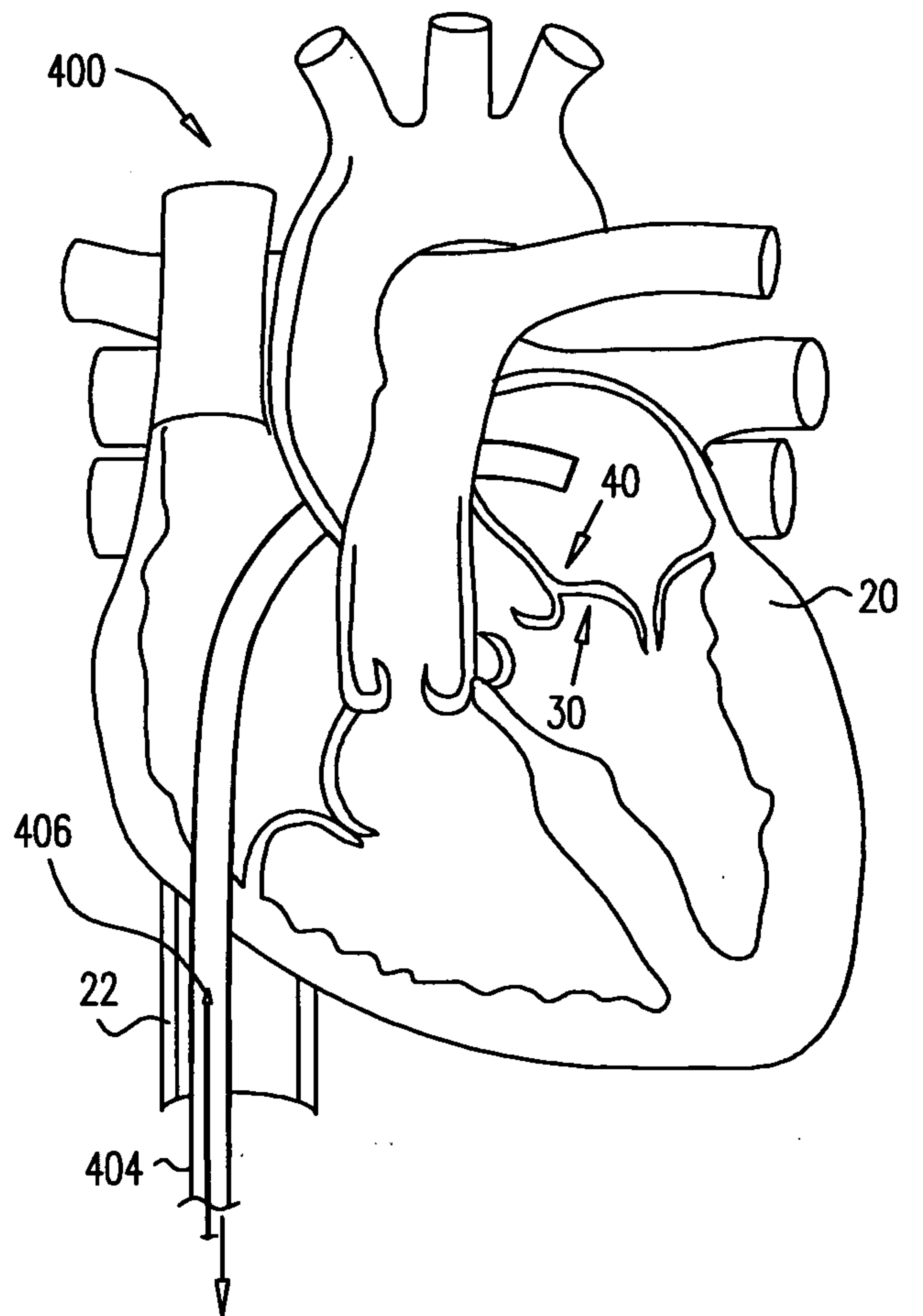

FIG. 17F



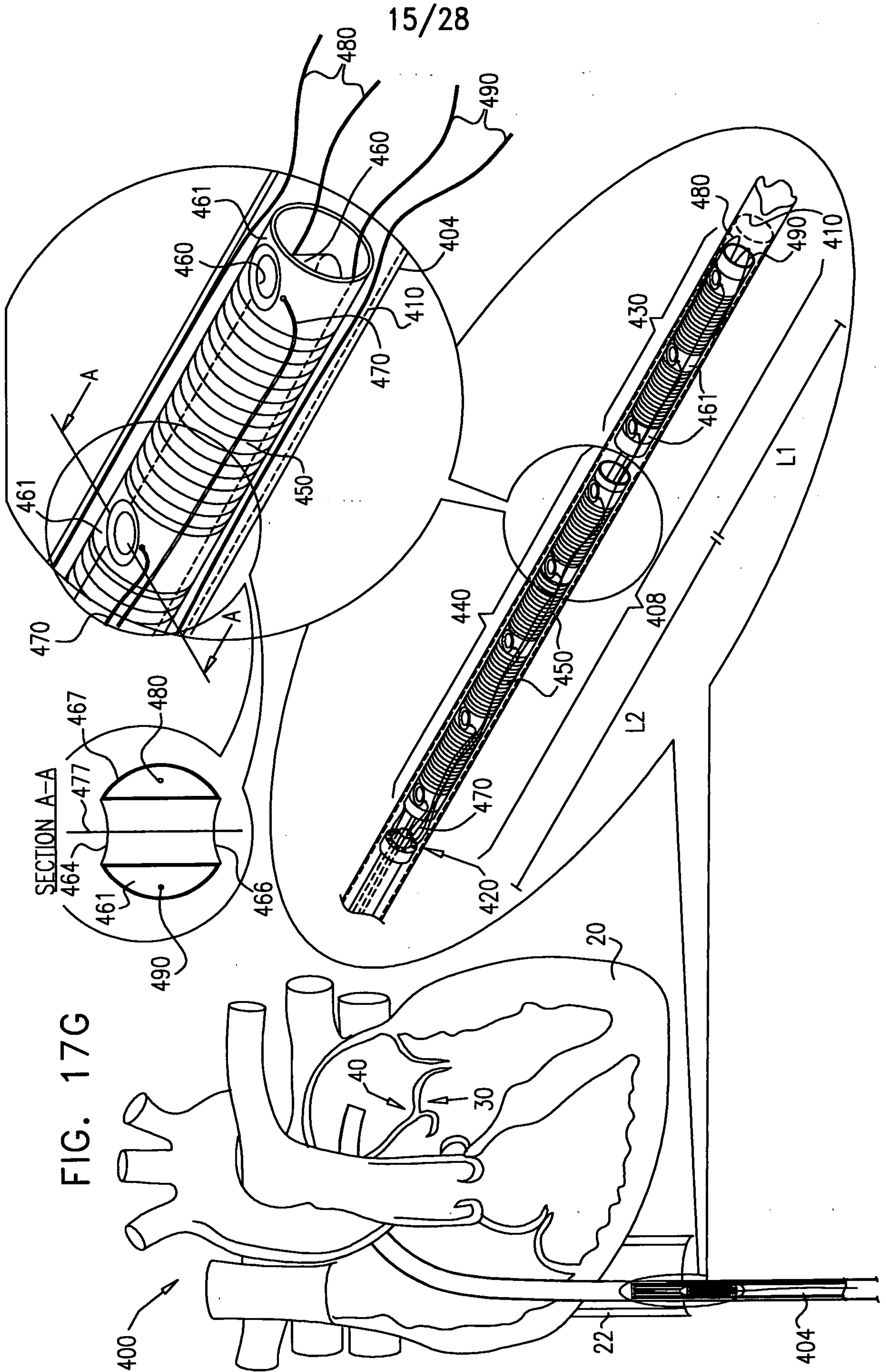

FIG. 17H

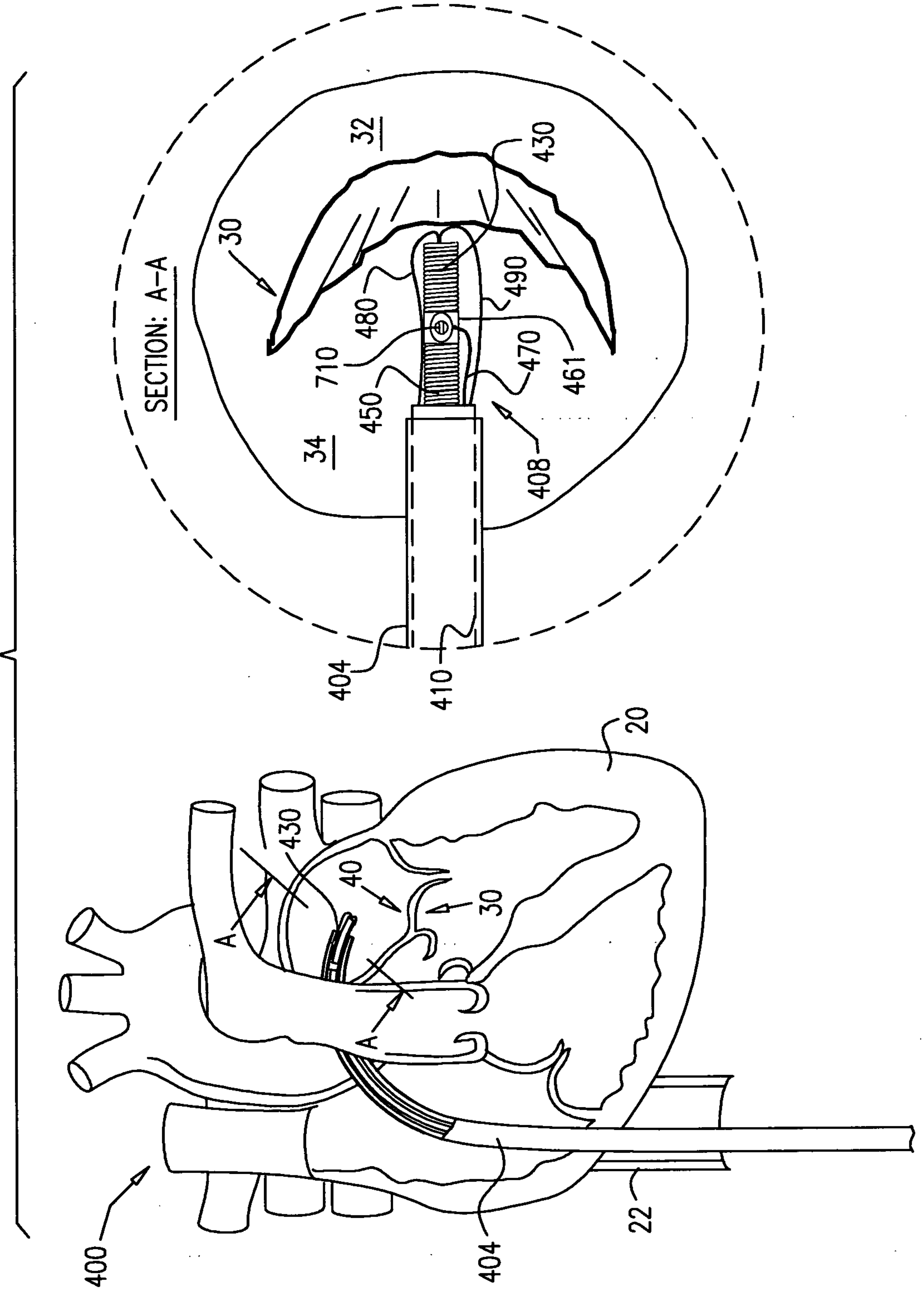

FIG. 171

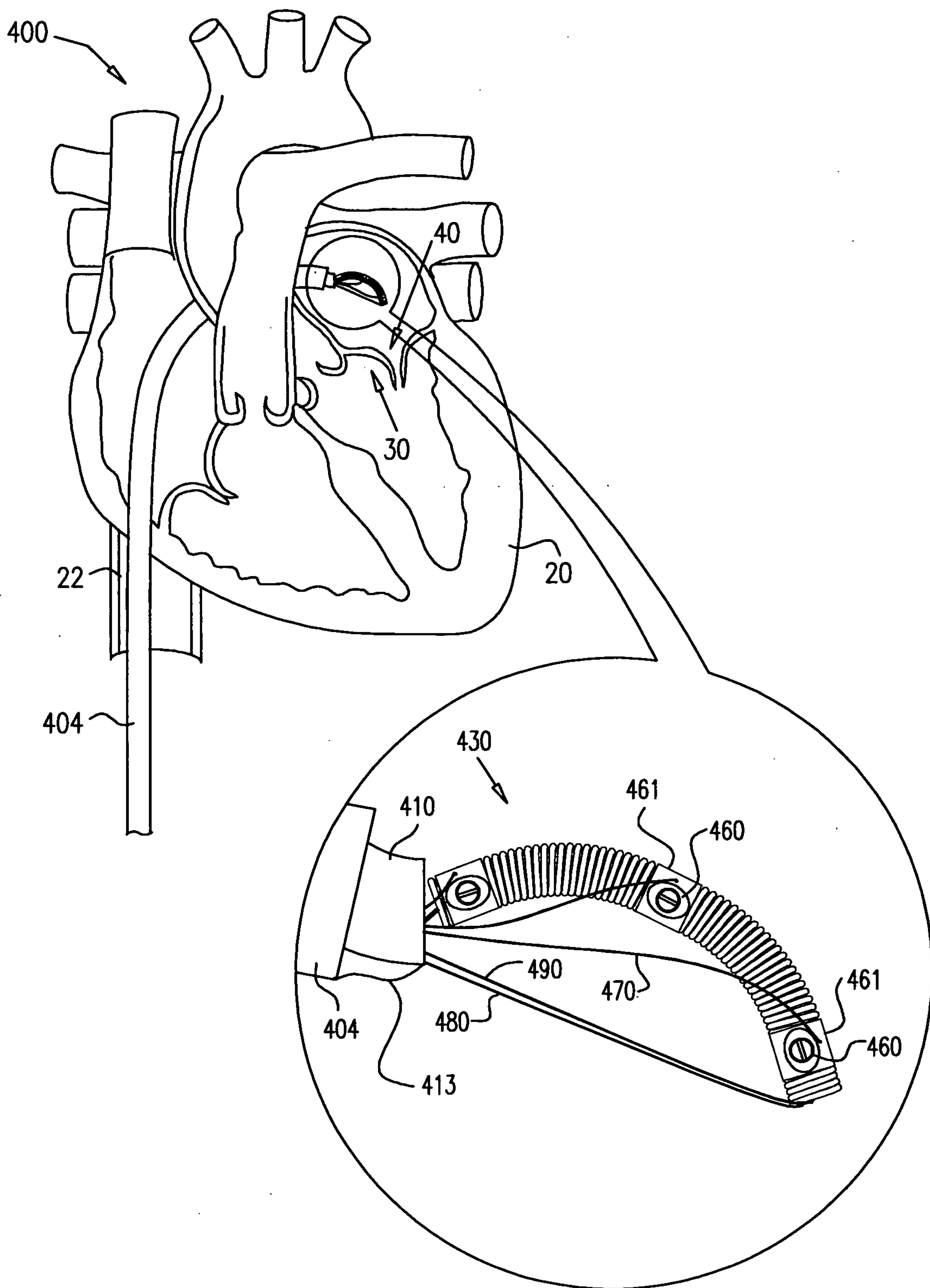
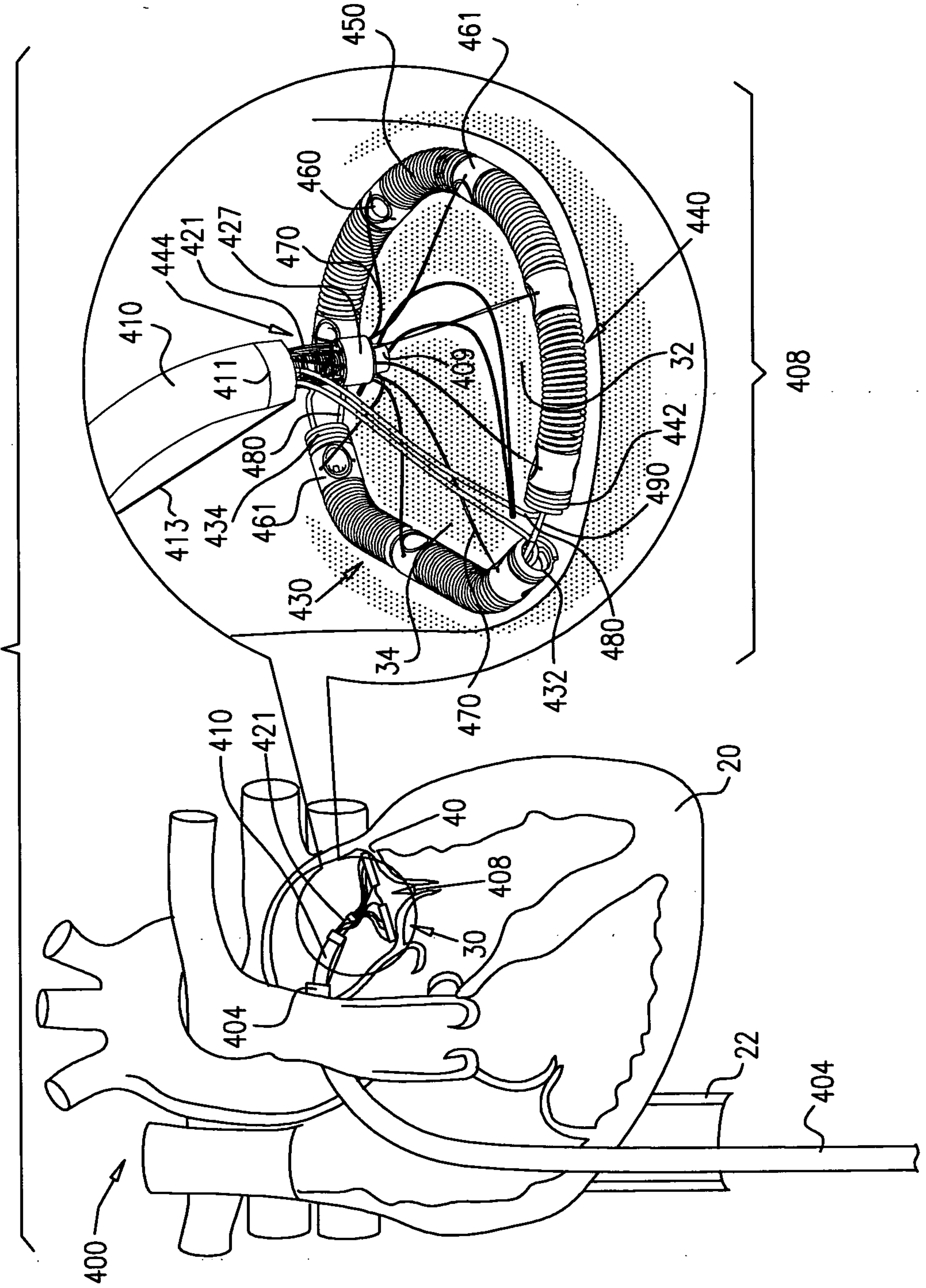

FIG. 18A



20/28

FIG. 18B

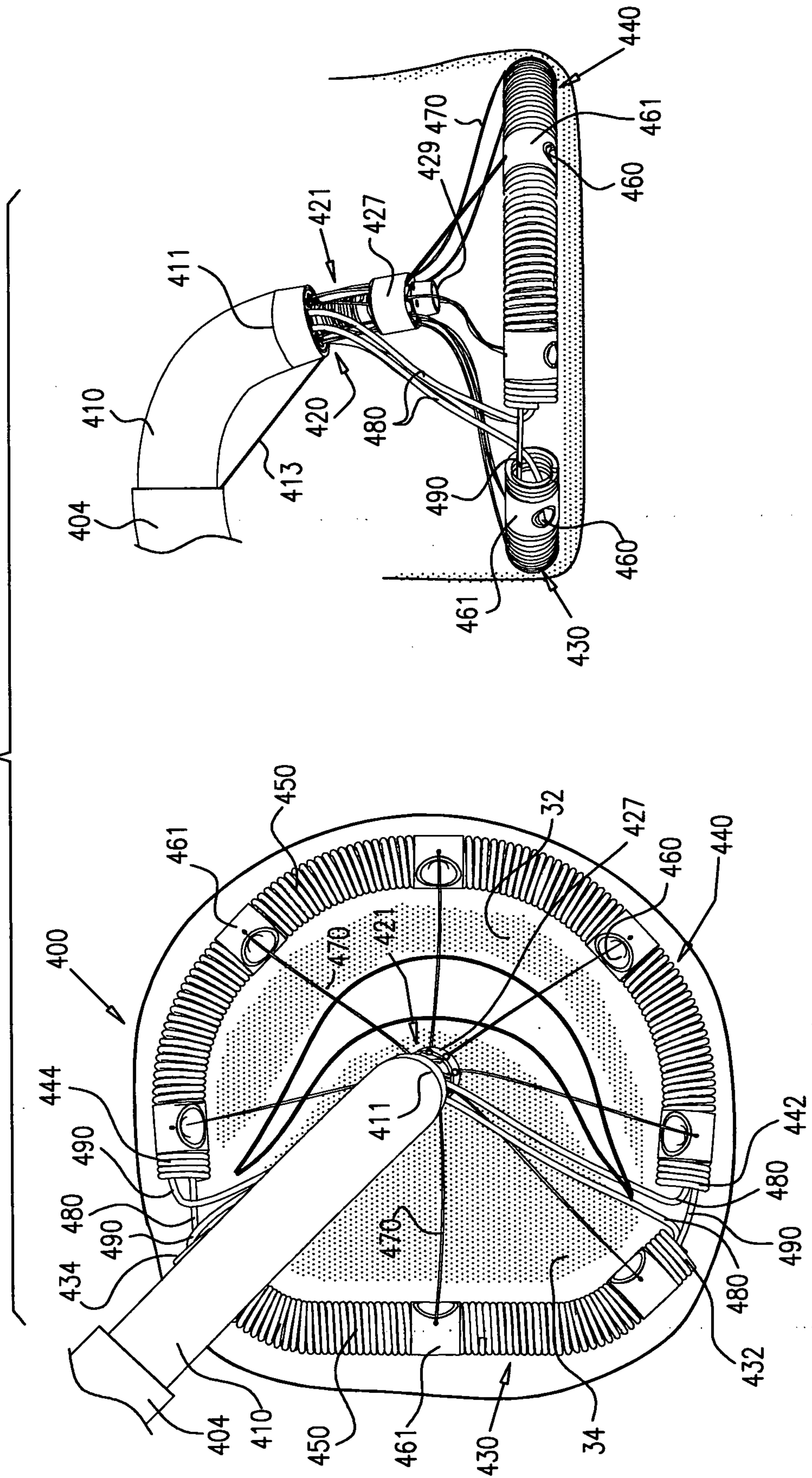
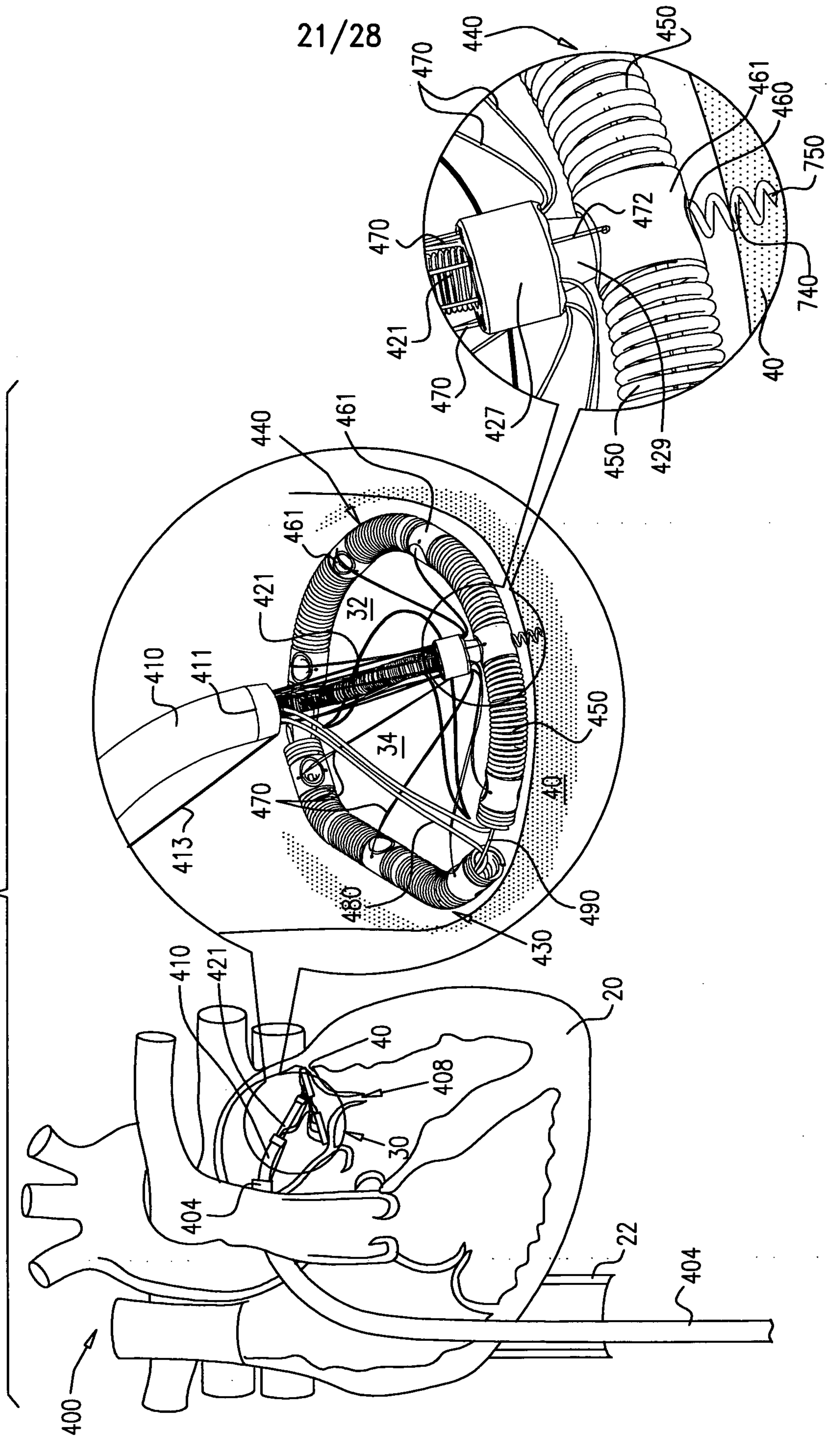
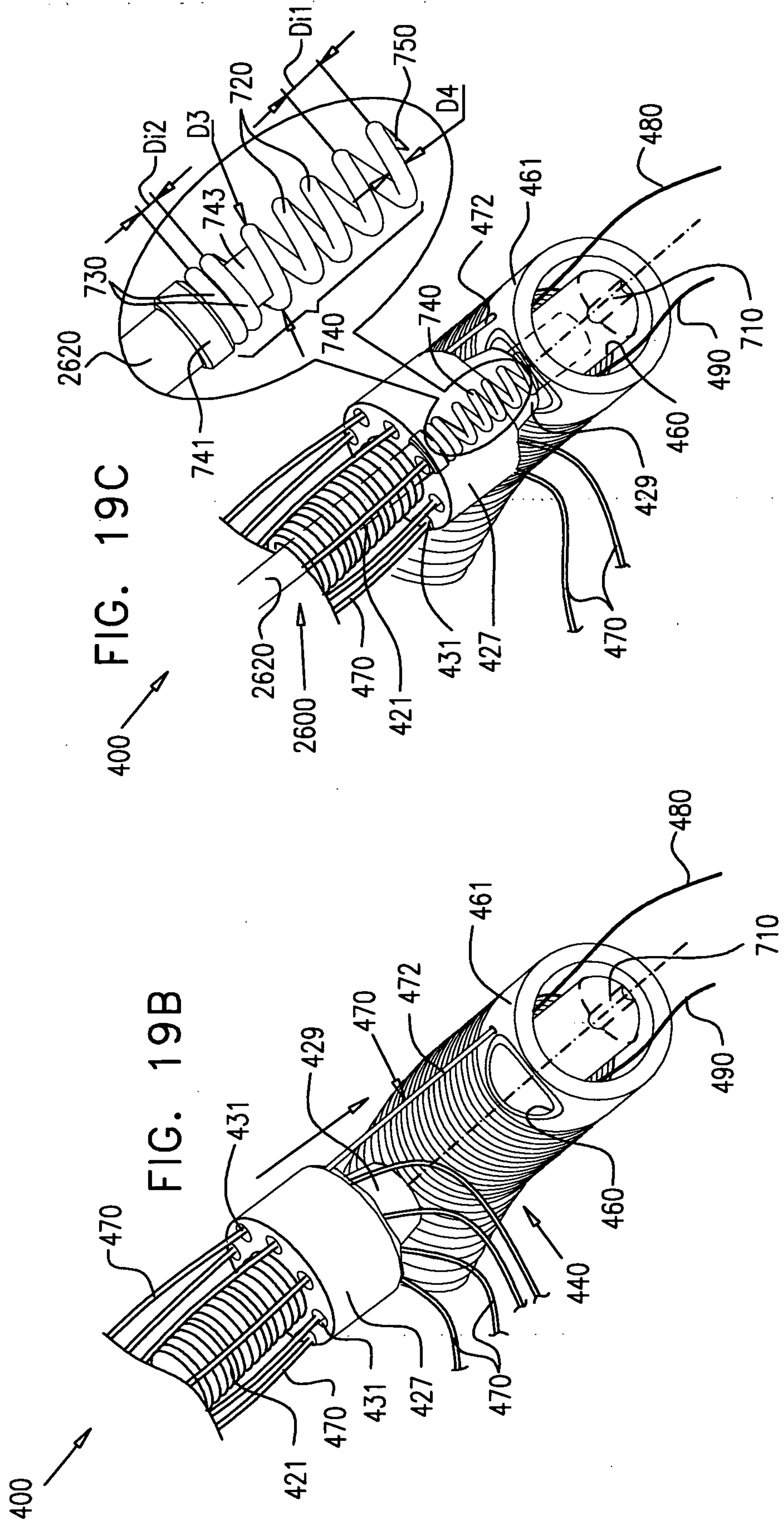

FIG. 19A





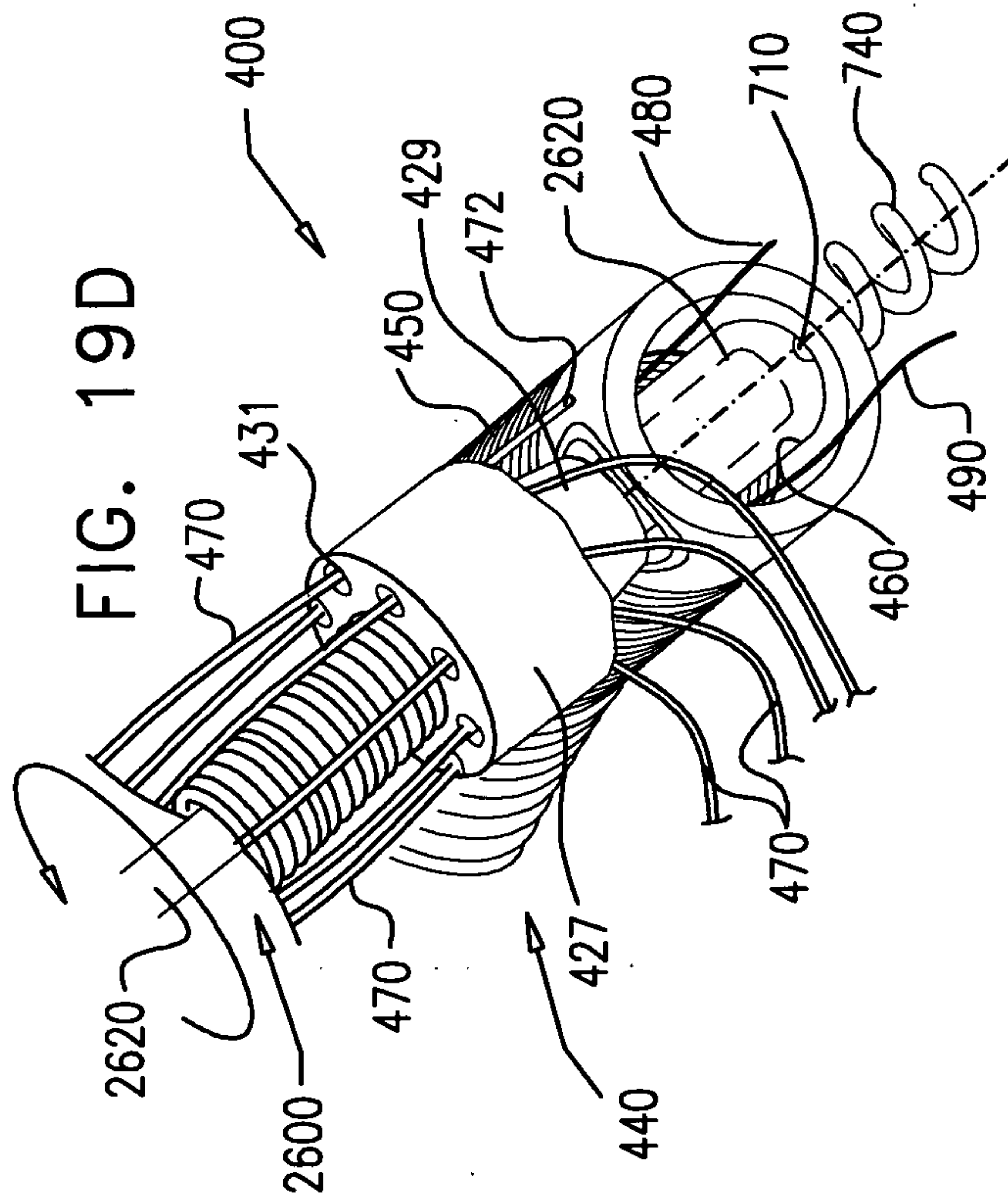
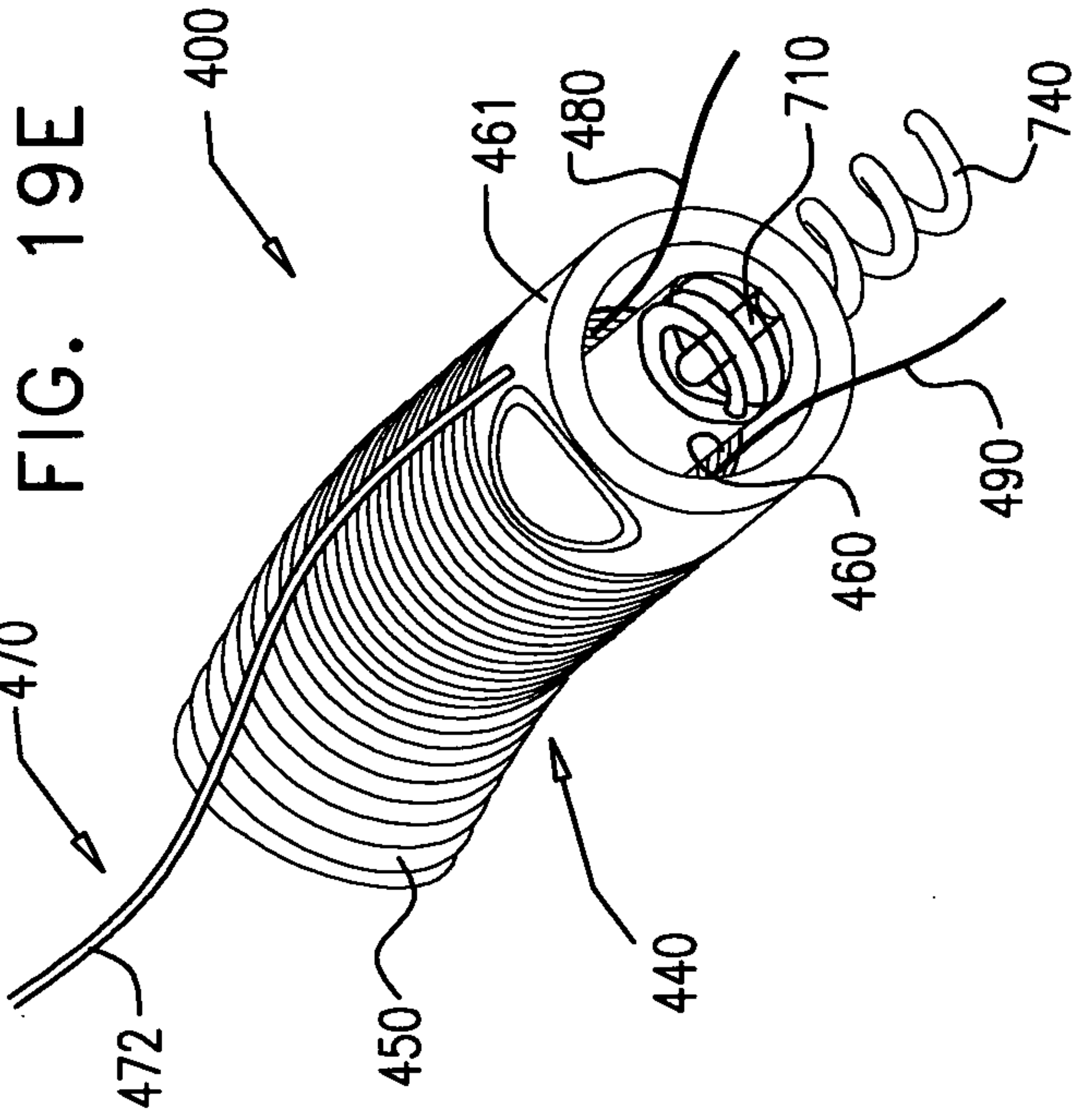

FIG. 20A

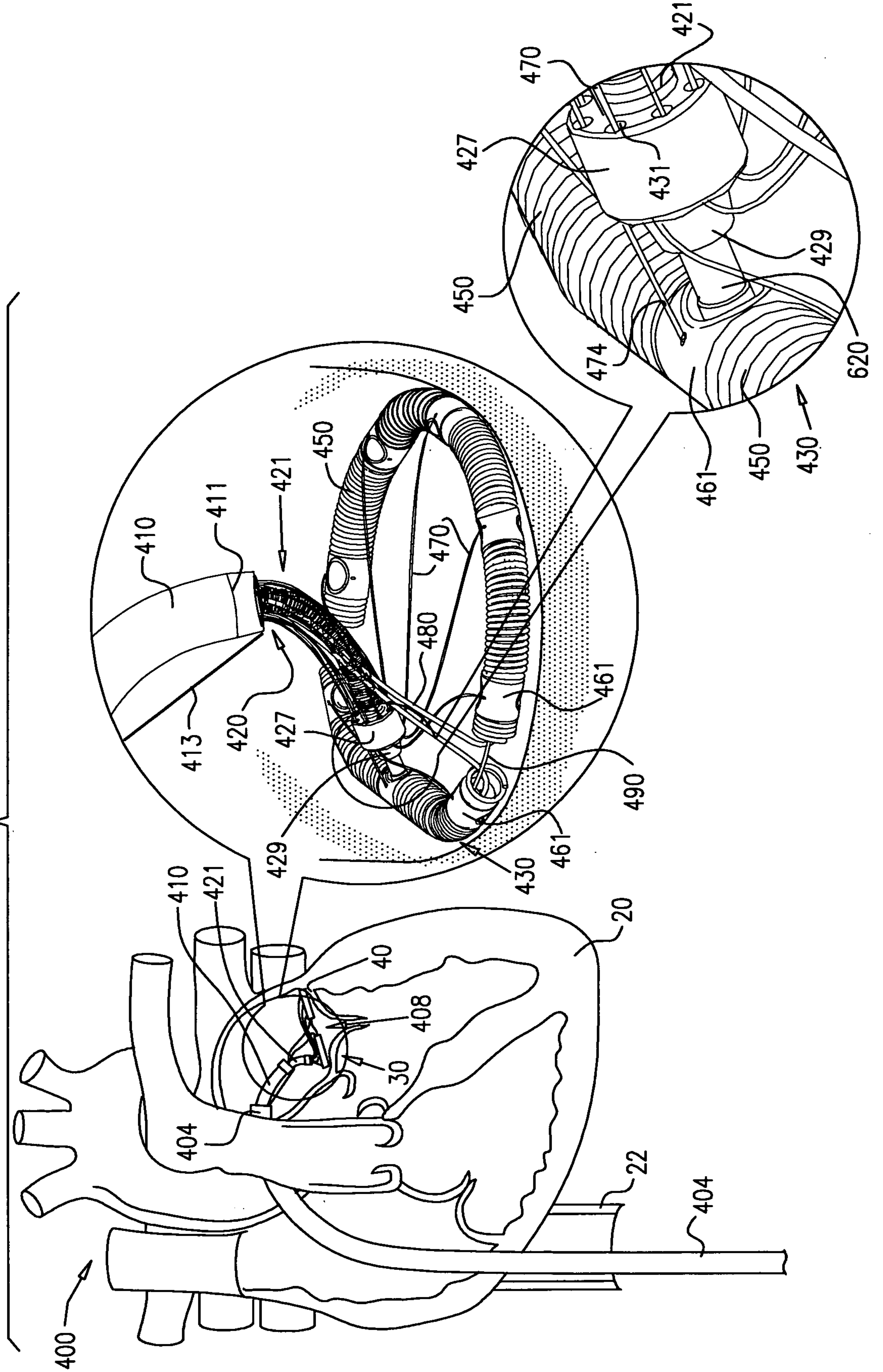
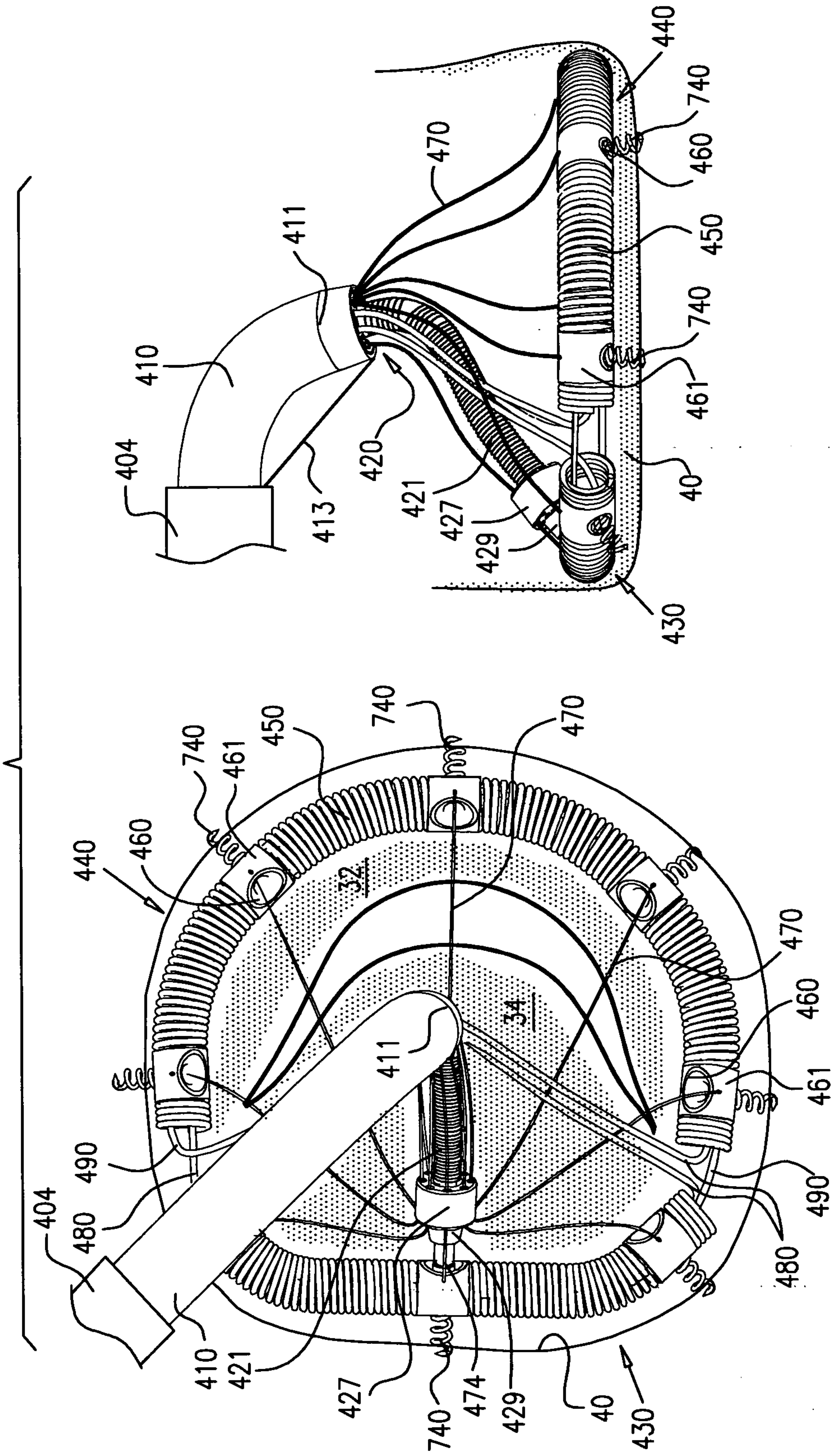
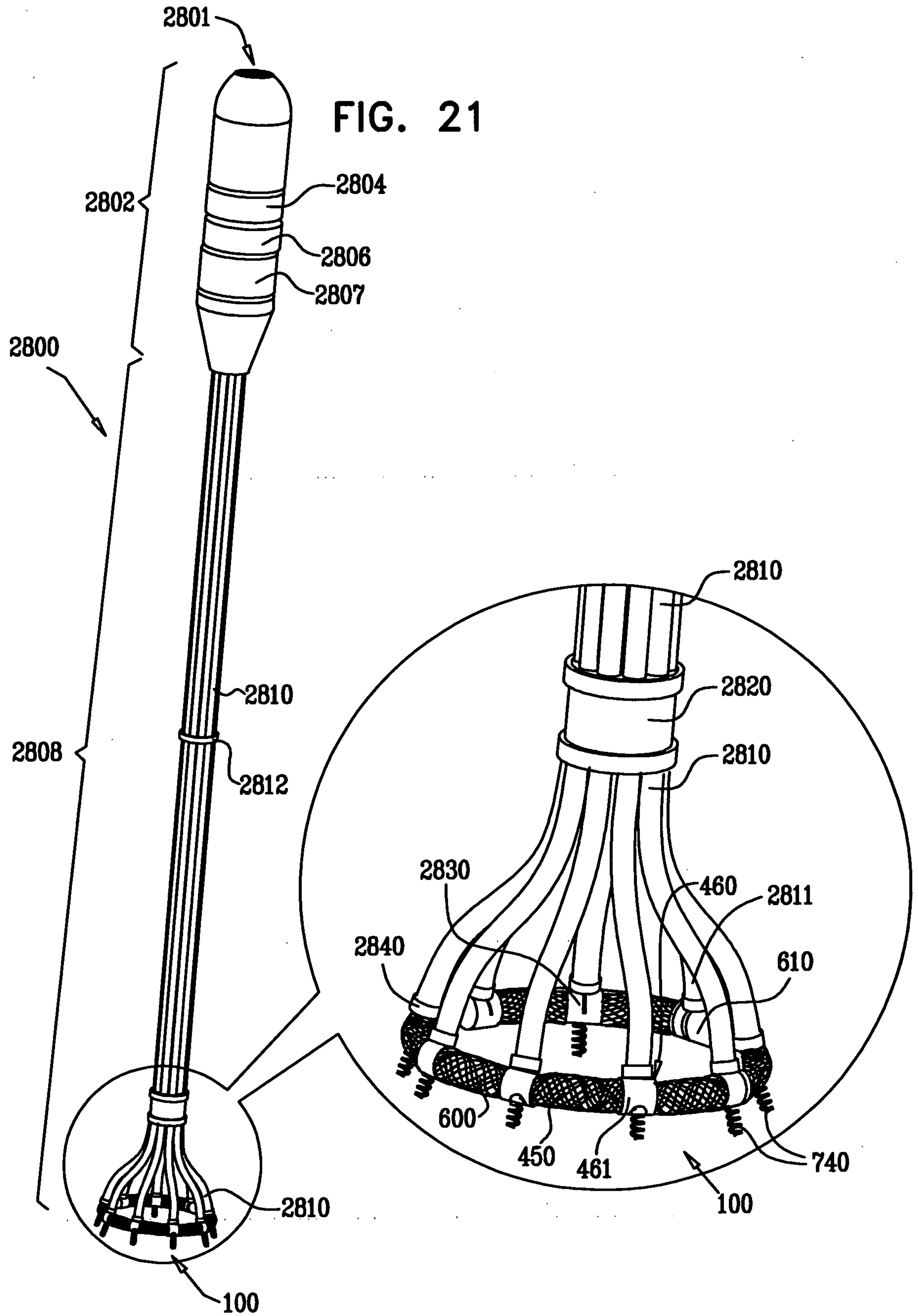

FIG. 20B





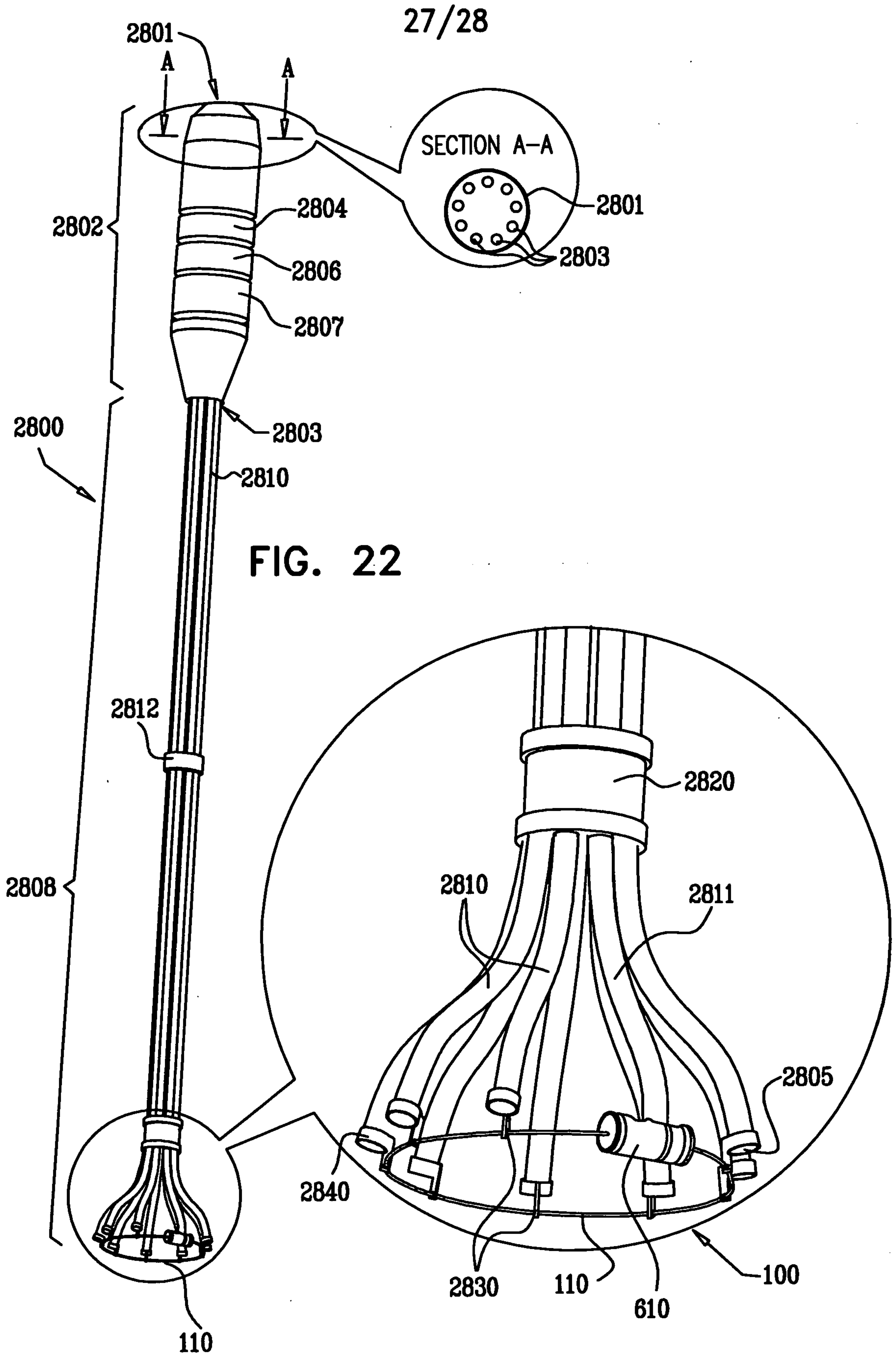

FIG. 23A

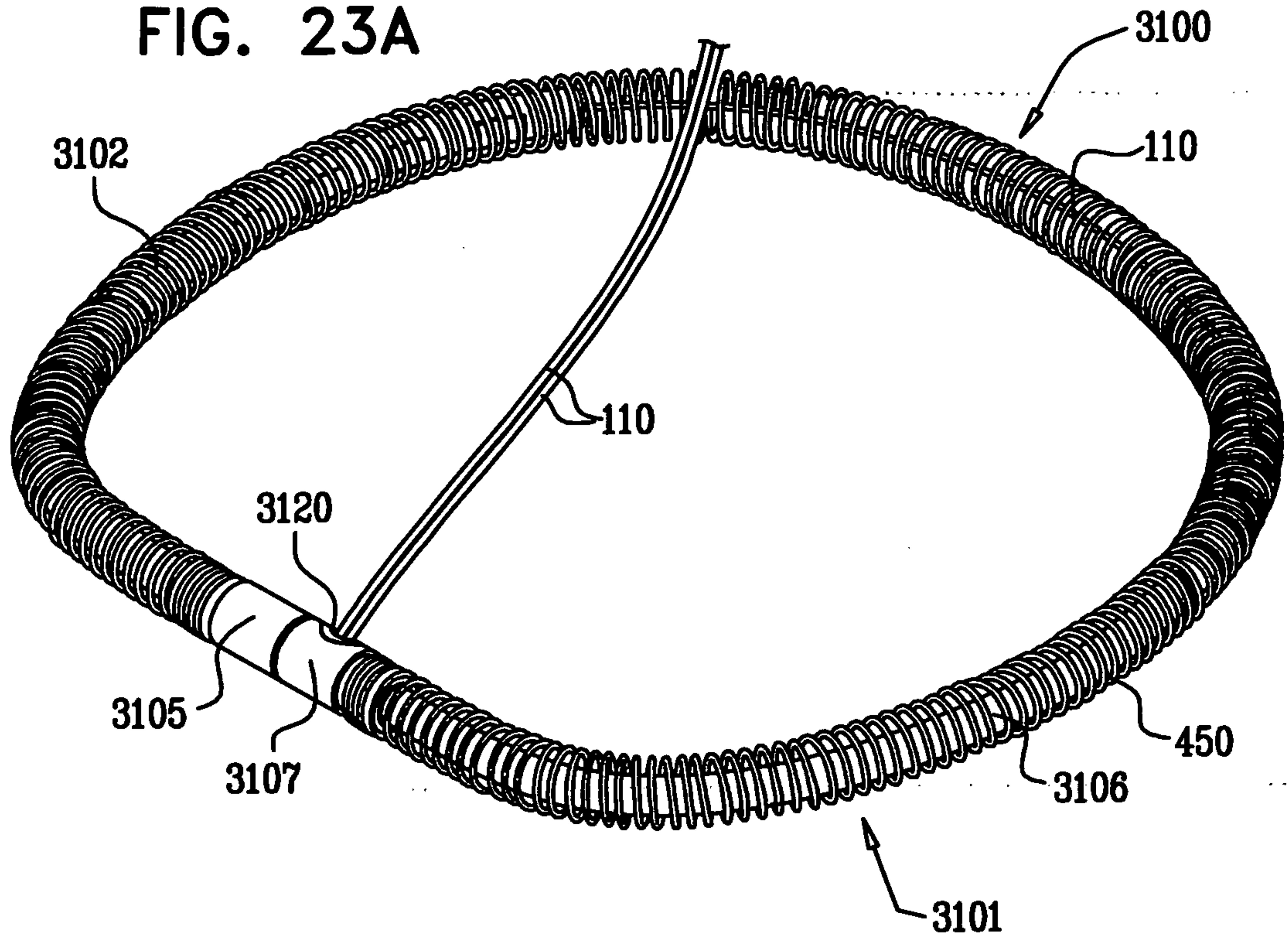

FIG. 23B

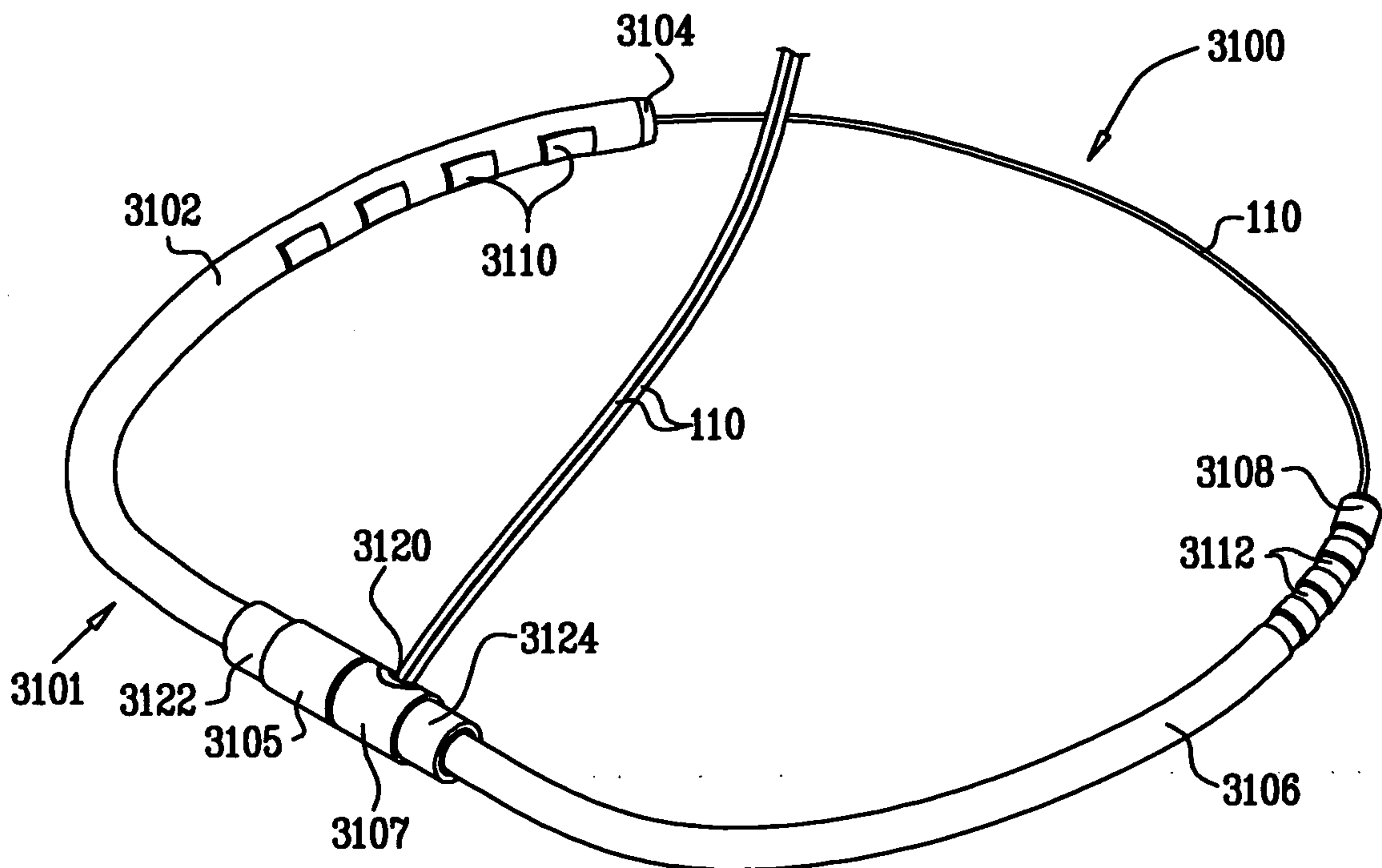

FIG. 1

