



(19) **United States**

(12) **Patent Application Publication**

**Soltys et al.**

(10) **Pub. No.: US 2005/0116417 A1**

(43) **Pub. Date: Jun. 2, 2005**

(54) **METHOD, APPARATUS AND ARTICLE FOR DUAL-SIDED PLAYING CARDS**

**Publication Classification**

(75) Inventors: **Richard Soltys**, Newcastle, WA (US);  
**Richard Huizinga**, Newcastle, WA (US)

(51) **Int. Cl.<sup>7</sup>** ..... **A63F 1/00**

(52) **U.S. Cl.** ..... **273/292; 273/303; 273/304**

Correspondence Address:  
**SEED INTELLECTUAL PROPERTY LAW GROUP PLLC**  
**701 FIFTH AVE**  
**SUITE 6300**  
**SEATTLE, WA 98104-7092 (US)**

(57) **ABSTRACT**

A dual-sided card deck allows for the contemporaneous play of two separate card games. The deck is comprised of a plurality of cards having a first set of values on a first side and a second set of values on a second side. A first card game is played using values assigned to symbols provided on the first side of each of the plurality of cards to determine the outcome of the first game. The outcome of a second card game is determined using the same hand of cards used to play the first game, but using values assigned to symbols provided on the second side of each of the plurality of cards held during the first game. To deter card counting, the symbols appearing on the first side of the plurality of cards can be pseudo-randomly generated and linked to the symbols appearing on the second side of the plurality of cards.

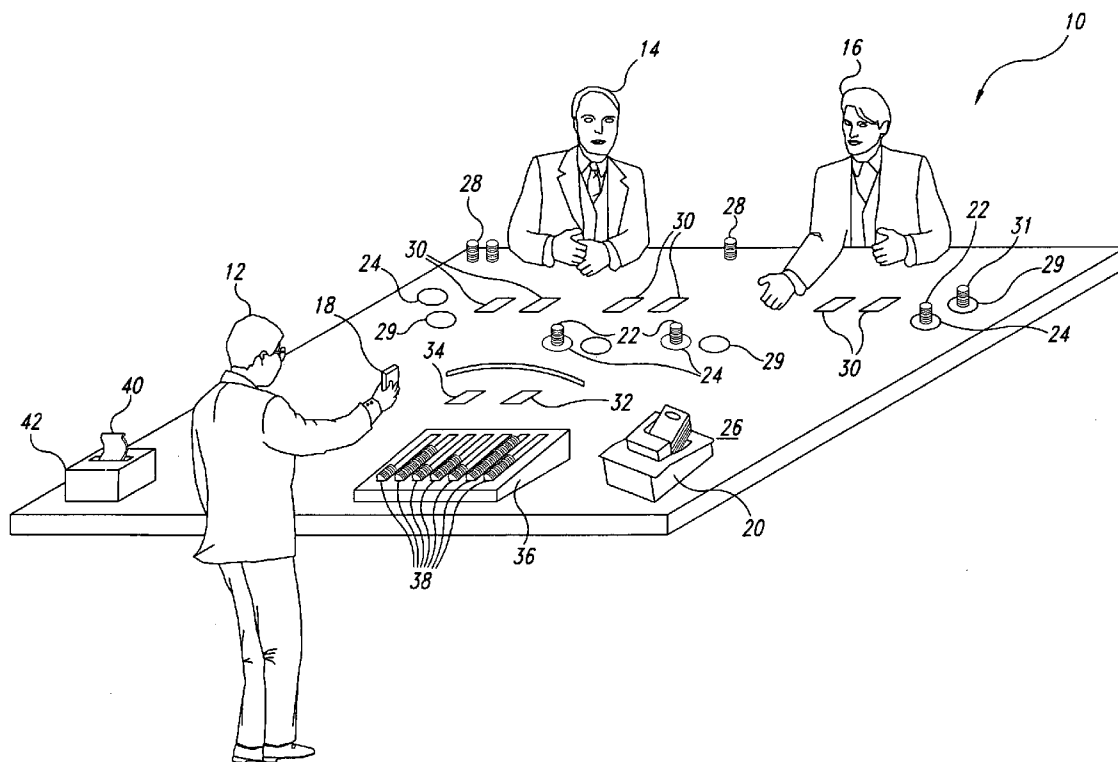
(73) Assignee: **ARL, Inc.**, Bellevue, WA

(21) Appl. No.: **10/902,436**

(22) Filed: **Jul. 29, 2004**

**Related U.S. Application Data**

(60) Provisional application No. 60/491,359, filed on Jul. 30, 2003.



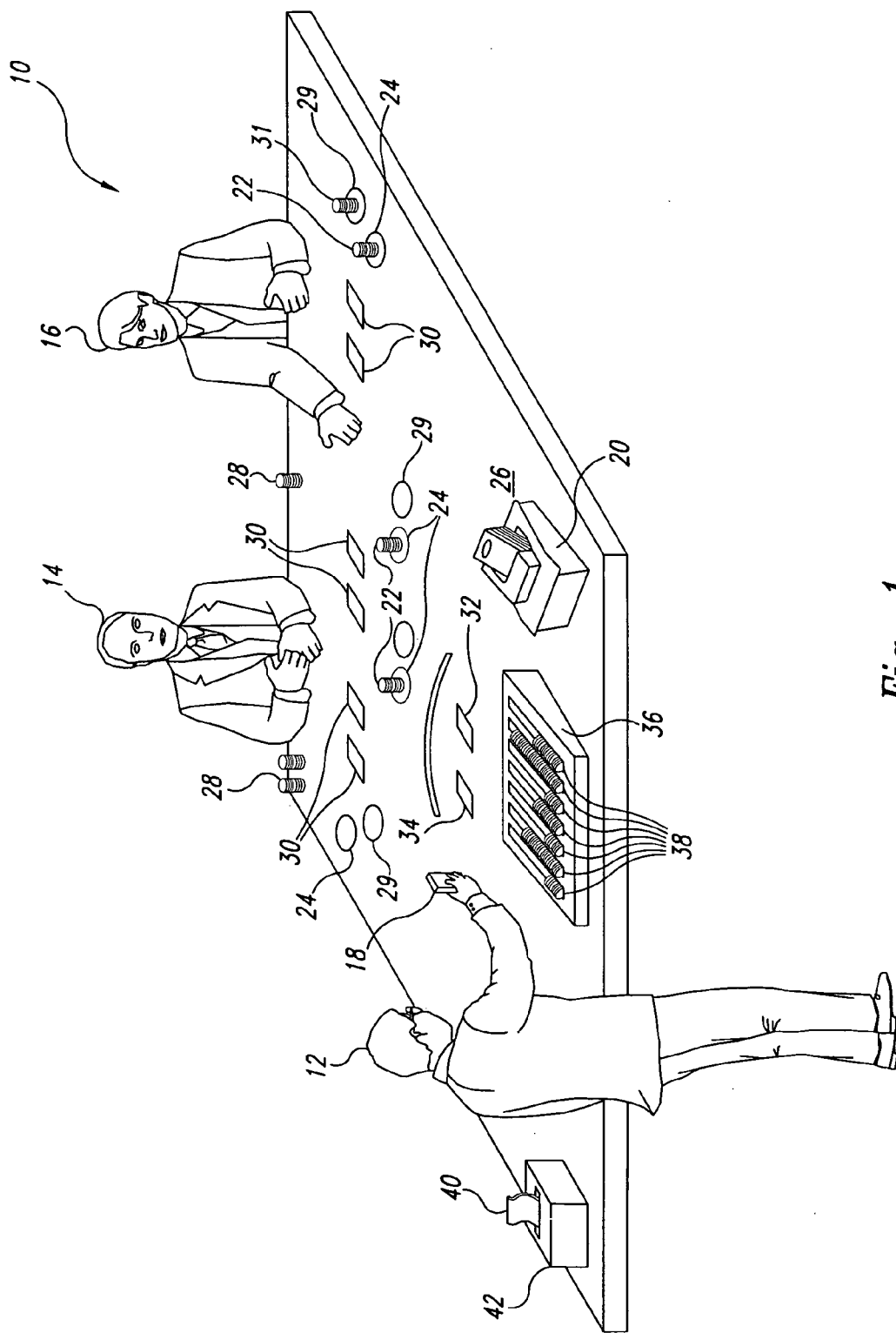


Fig. 1

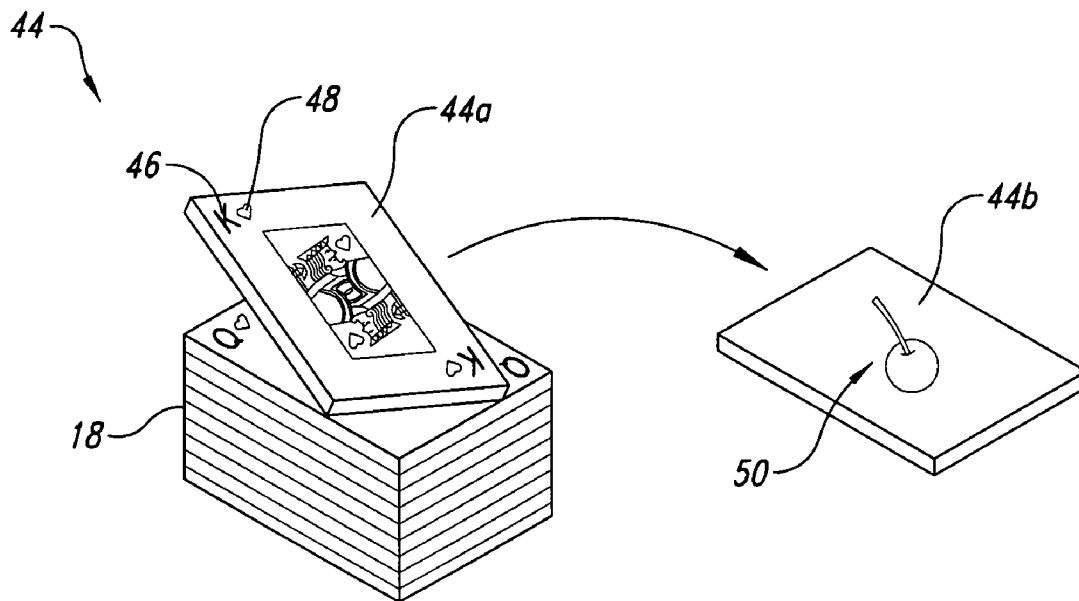


FIG. 2

14





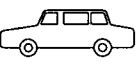


Example Symbols	
52 Rank Symbols:	e.g., 1-10, Jack, Queen, King, Ace or by numerical values such as 2-100
54 Suit Symbols:	e.g.,    
56 Pictorial Symbols:	e.g.,   
58 Number Symbols:	e.g., 0, 5, 10, 20
60 Text Symbols:	e.g., "You Win"
62 Color Symbols:	e.g., blue card, yellow card
64 Amount Symbols:	e.g., \$100, \$10,000

FIG. 3

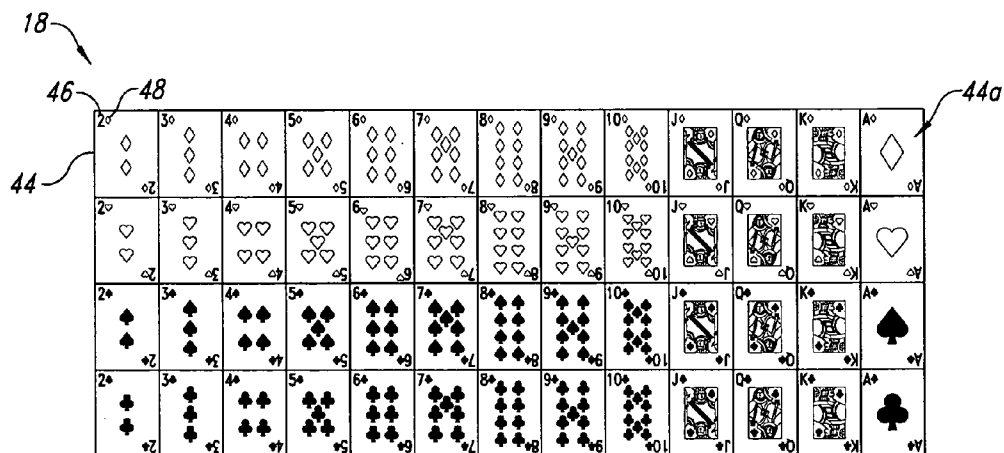


FIG. 4A

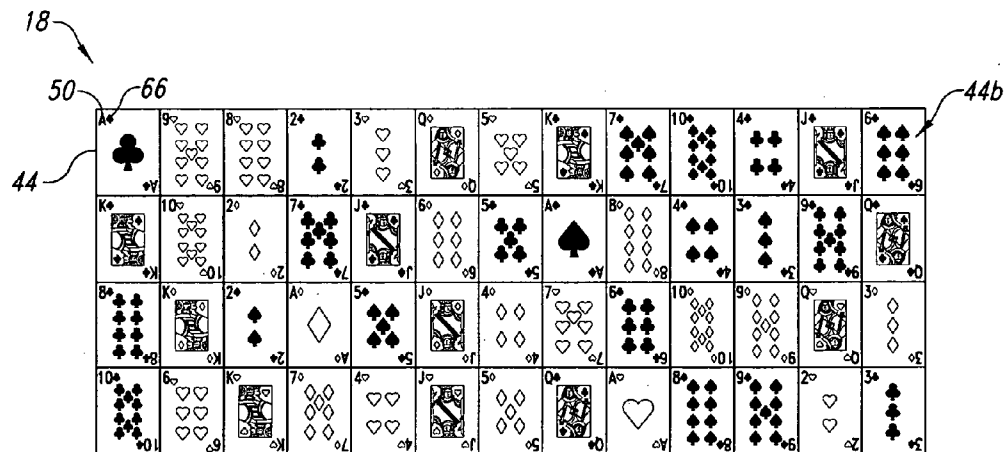


FIG. 4B

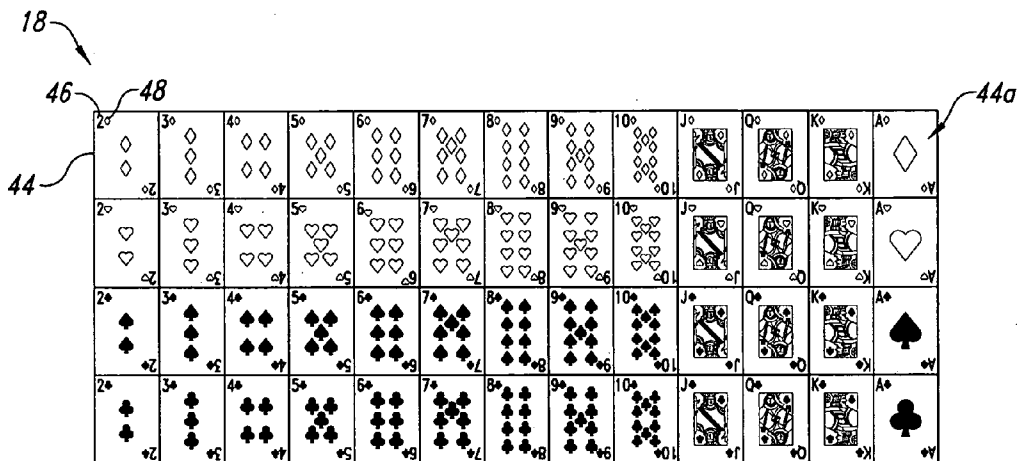


FIG. 5A

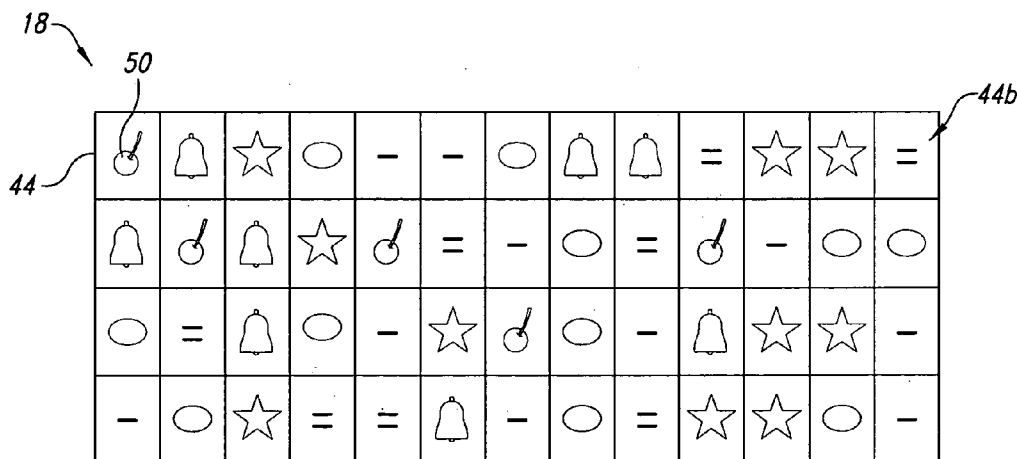


FIG. 5B

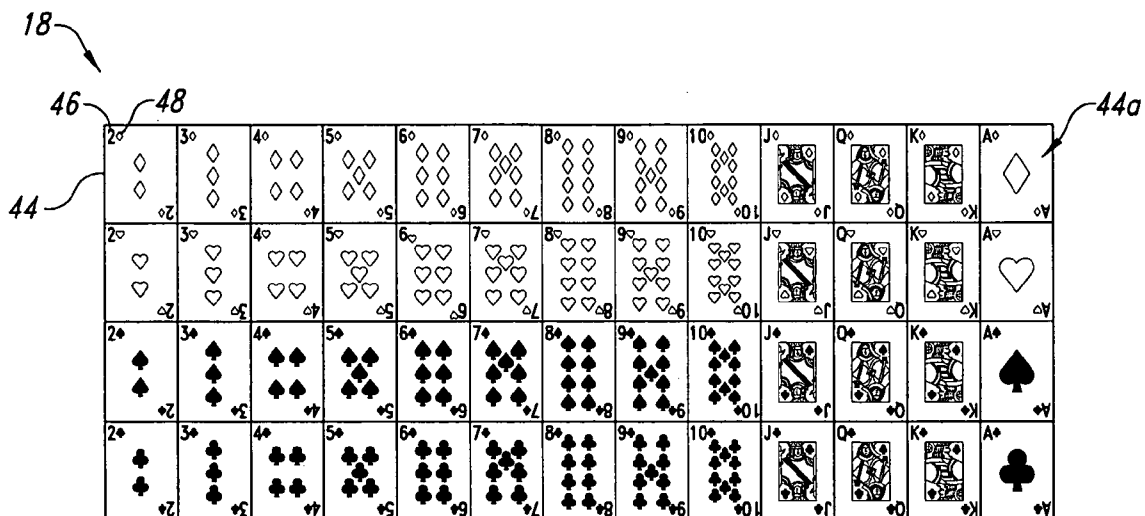


FIG. 6A

FIG. 6B is a 4x13 grid of numbers. The numbers are arranged in a pattern. Reference numeral 18 points to the top-left corner. Reference numeral 44 points to the left edge. Reference numeral 50 points to the top row. Reference numeral 44b points to the top-right corner.

5	5	5	20	20	5	5	5	20	5	5	5	5
5	5	10	20	10	10	10	5	5	5	5	5	5
10	10	10	20	10	10	10	5	5	5	10	5	5
20	10	20	20	10	10	10	5	5	5	5	5	5

FIG. 6B

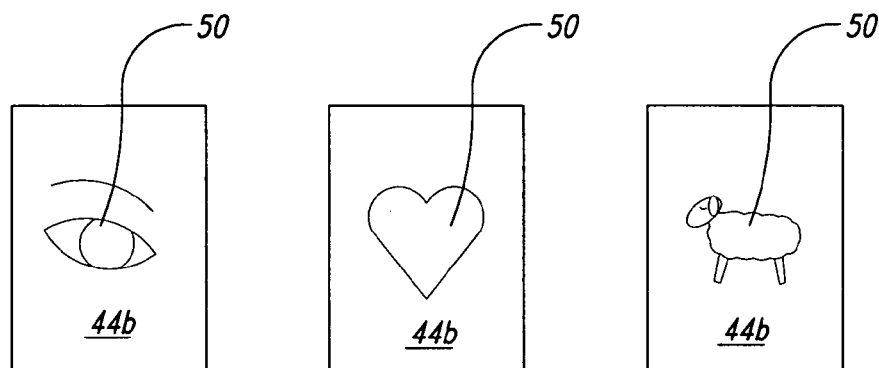
5	5	5	20	20	5	5	5	20	5	5	5	5
5	5	10	20	10	10	10	5	5	5	5	5	5
10	10	10	20	10	10	10	5	5	5	10	5	5
20	10	20	20	10	10	10	5	5	5	5	5	5

FIG. 7A

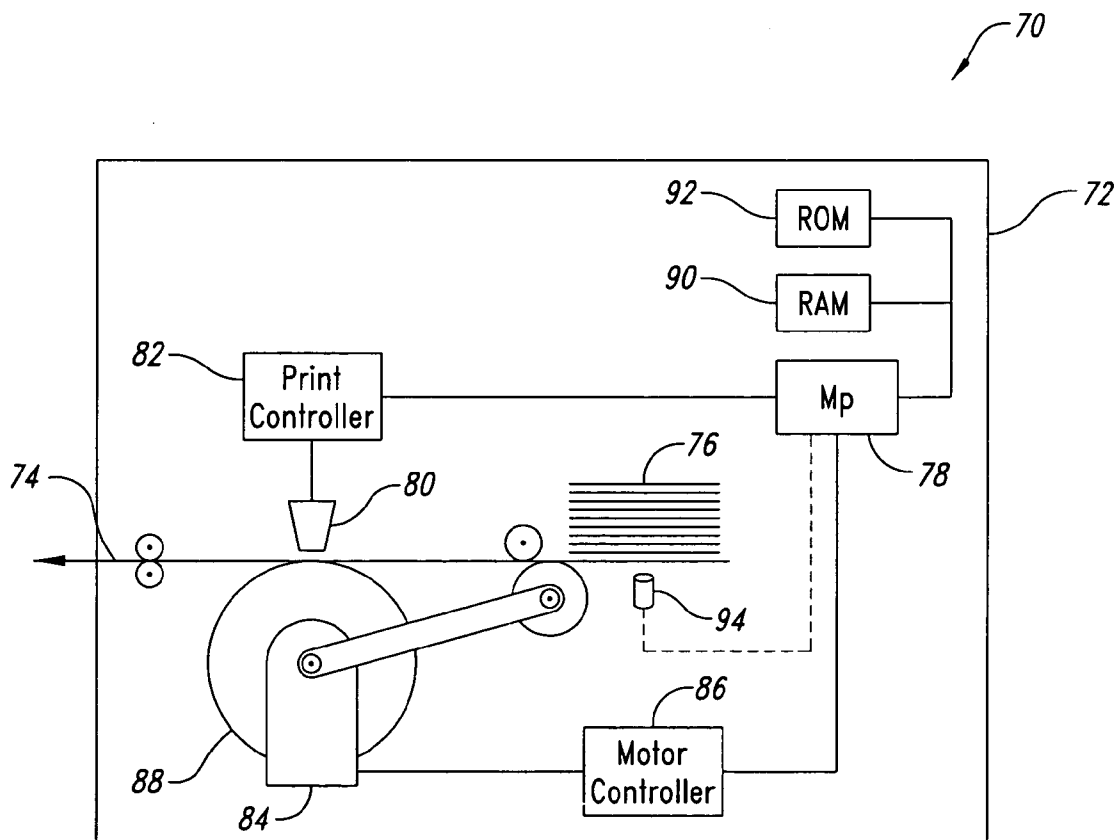
Apple	Horizontal Lines	Car	Dinner	Clover	Horizontal Lines	Bell	Apple	
Clover	Horizontal Lines	Apple	Horizontal Lines	Horizontal Lines	Apple	Horizontal Lines	Horizontal Lines	Clover
Pineapple	Apple	Pineapple	\$10,000	Apple	Pineapple			
Bell	Apple	Clover	Horizontal Lines	Bell	Clover			

FIG. 7B





**FIG. 8**



**FIG. 9**

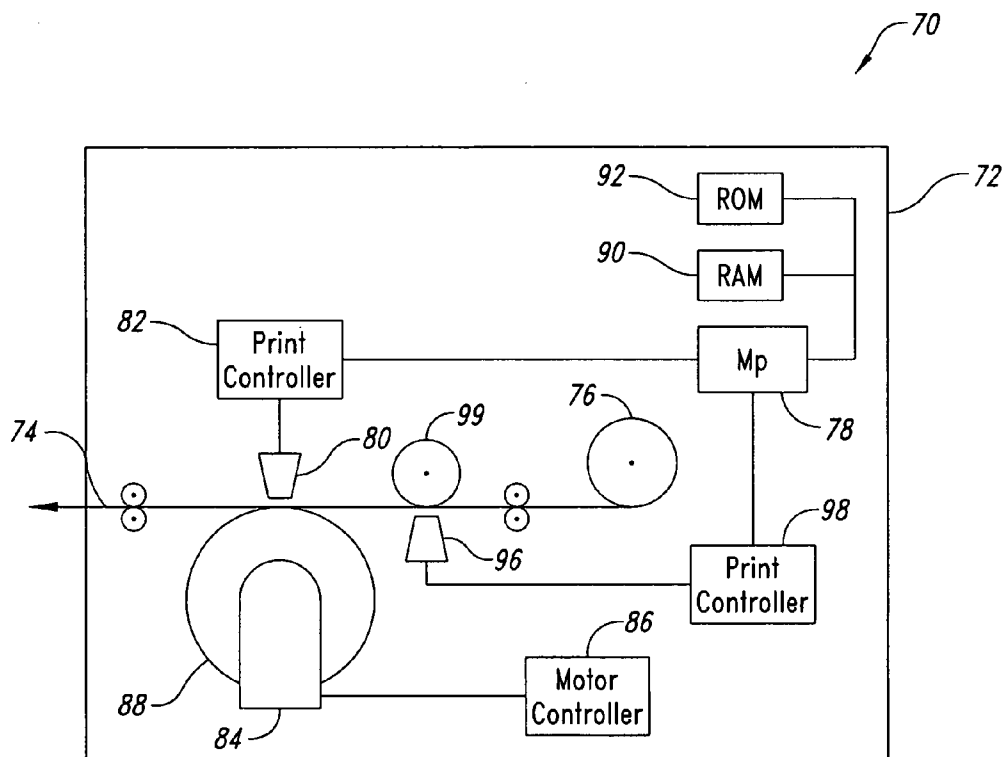
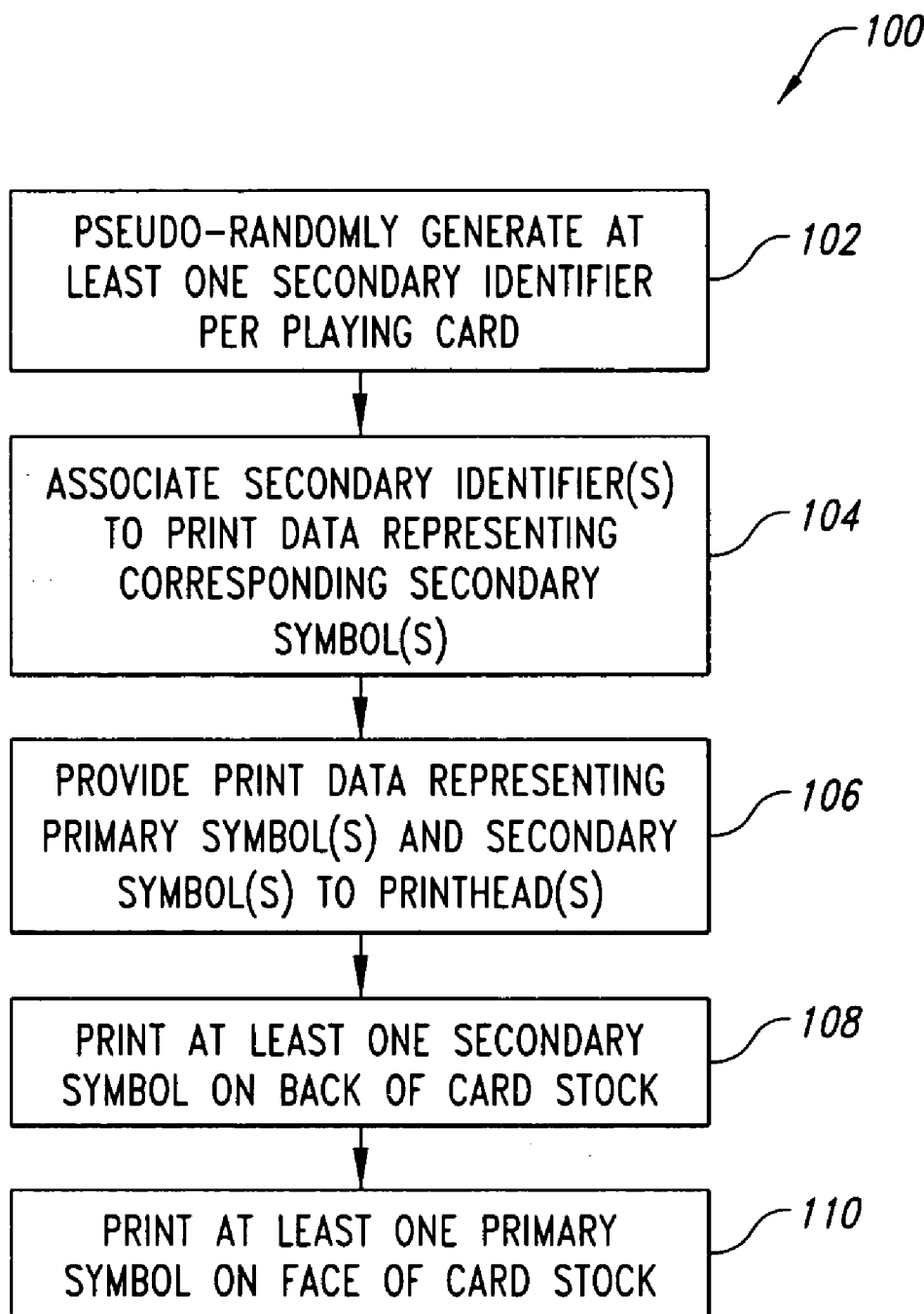


FIG. 10



*FIG. 11*

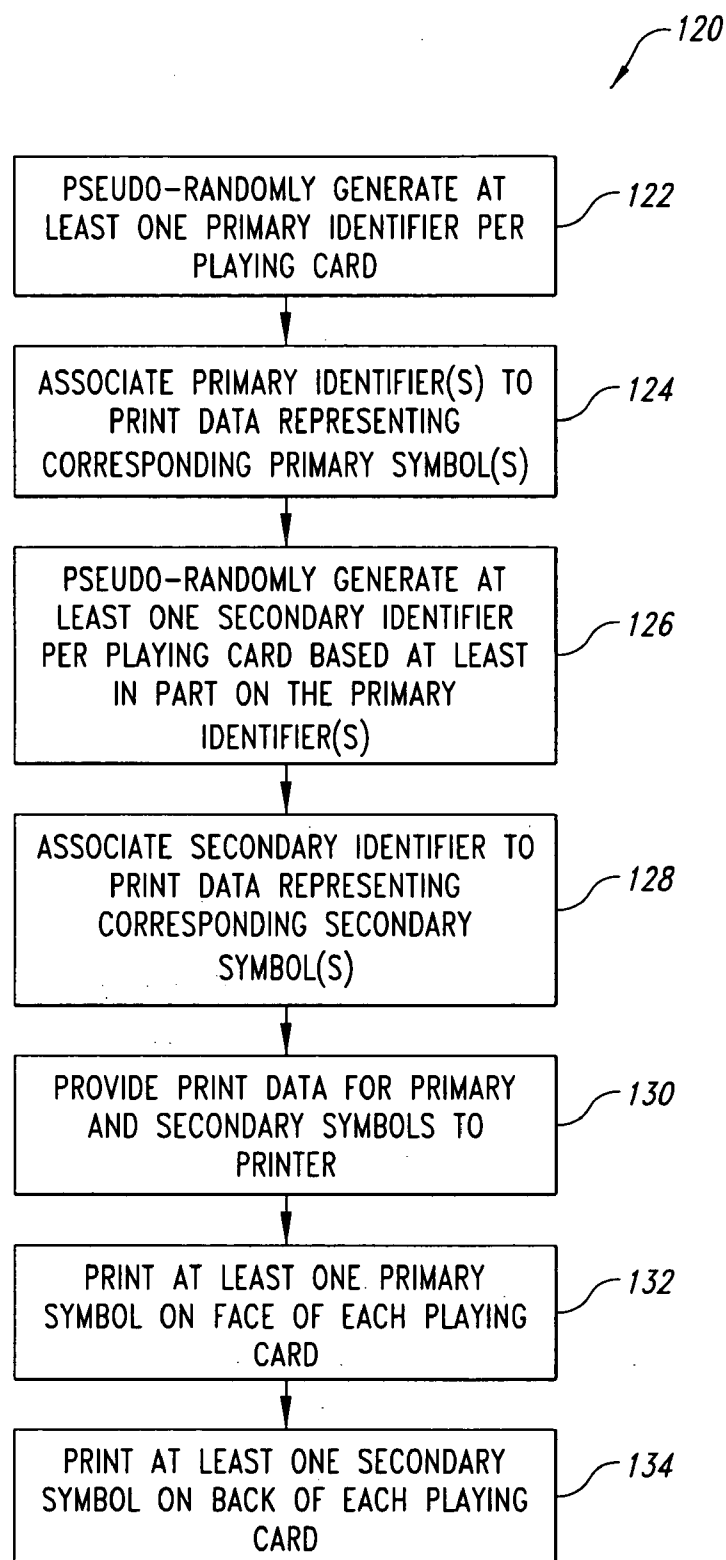
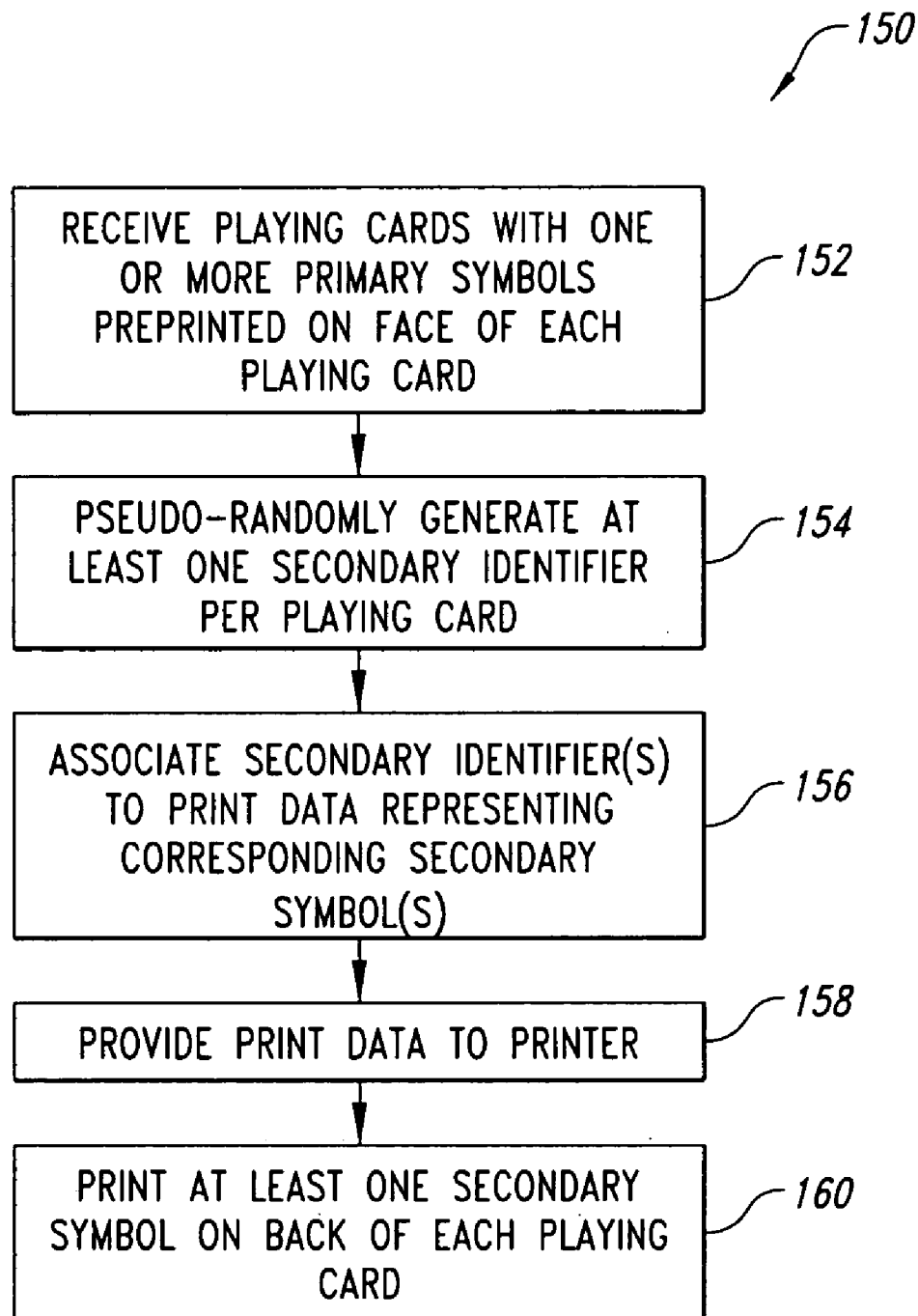


FIG. 12



*FIG. 13*

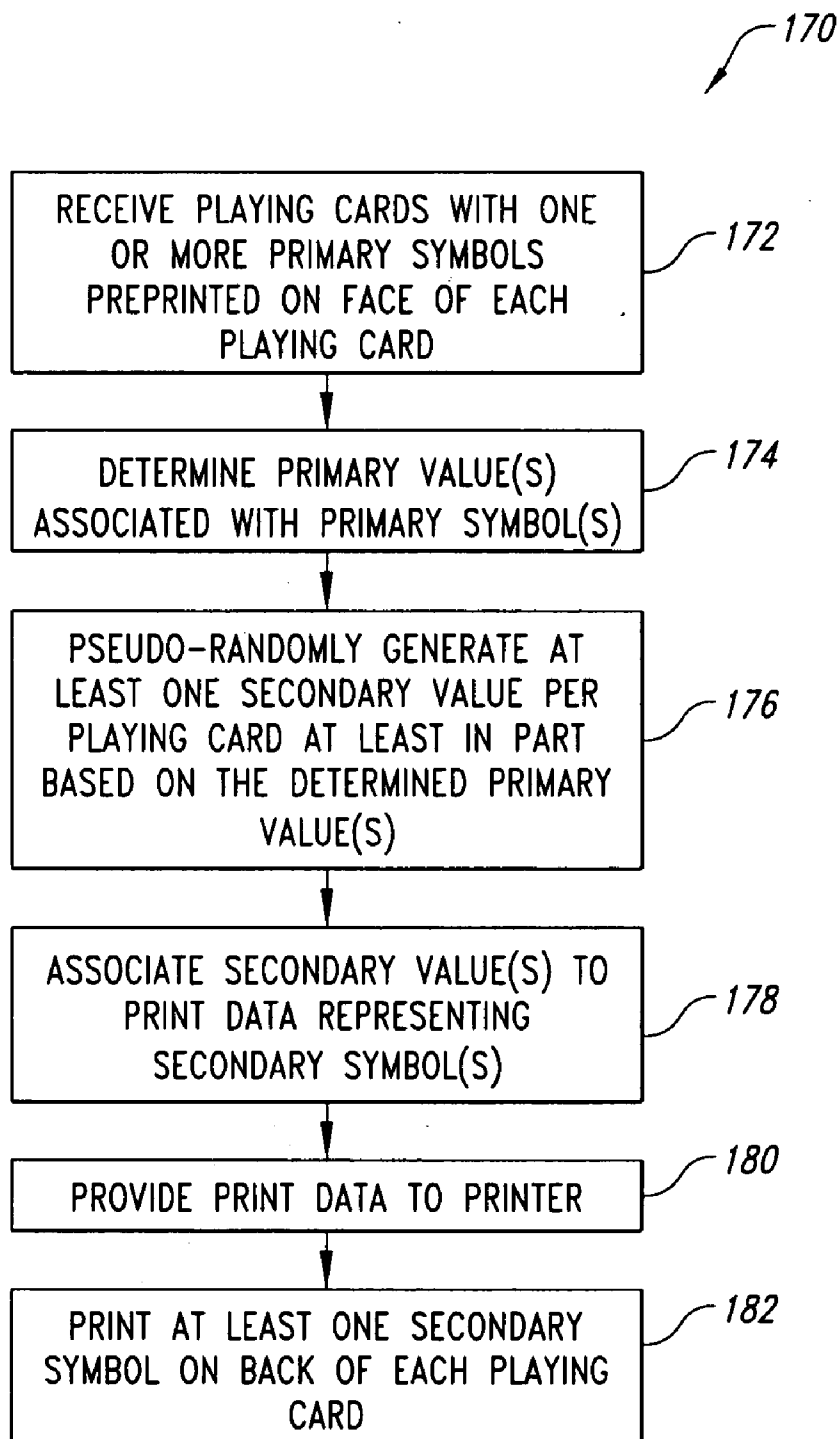
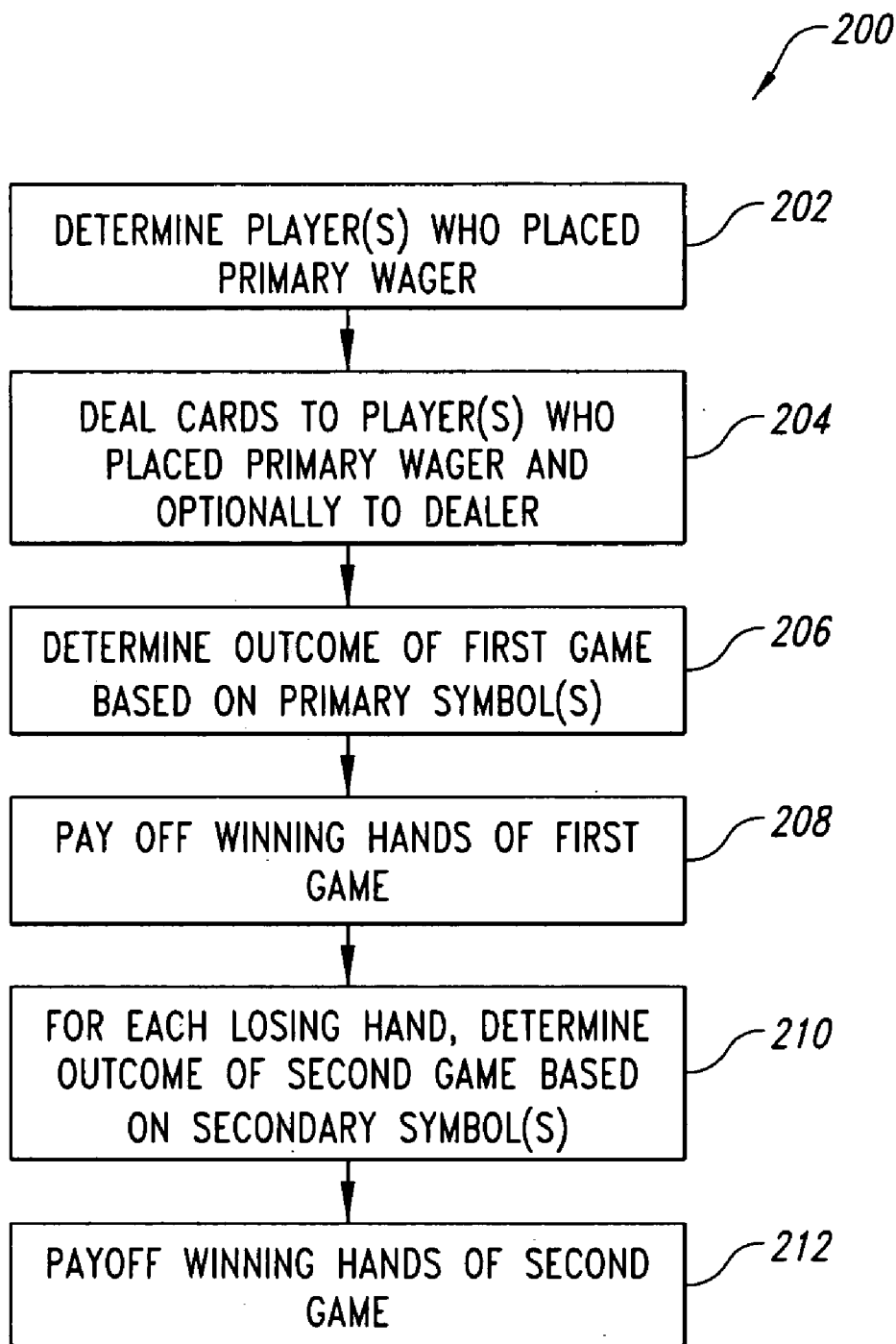
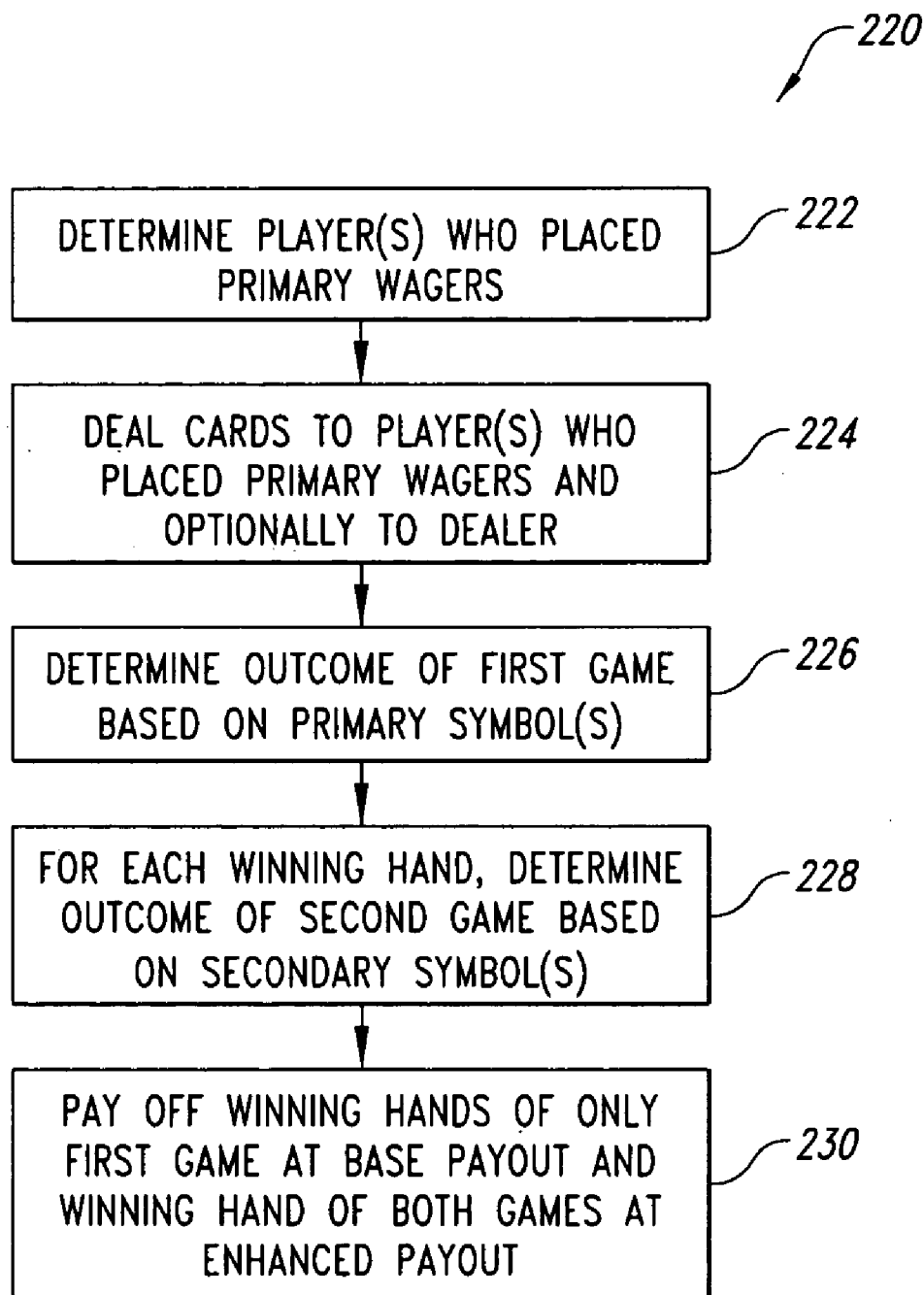


FIG. 14

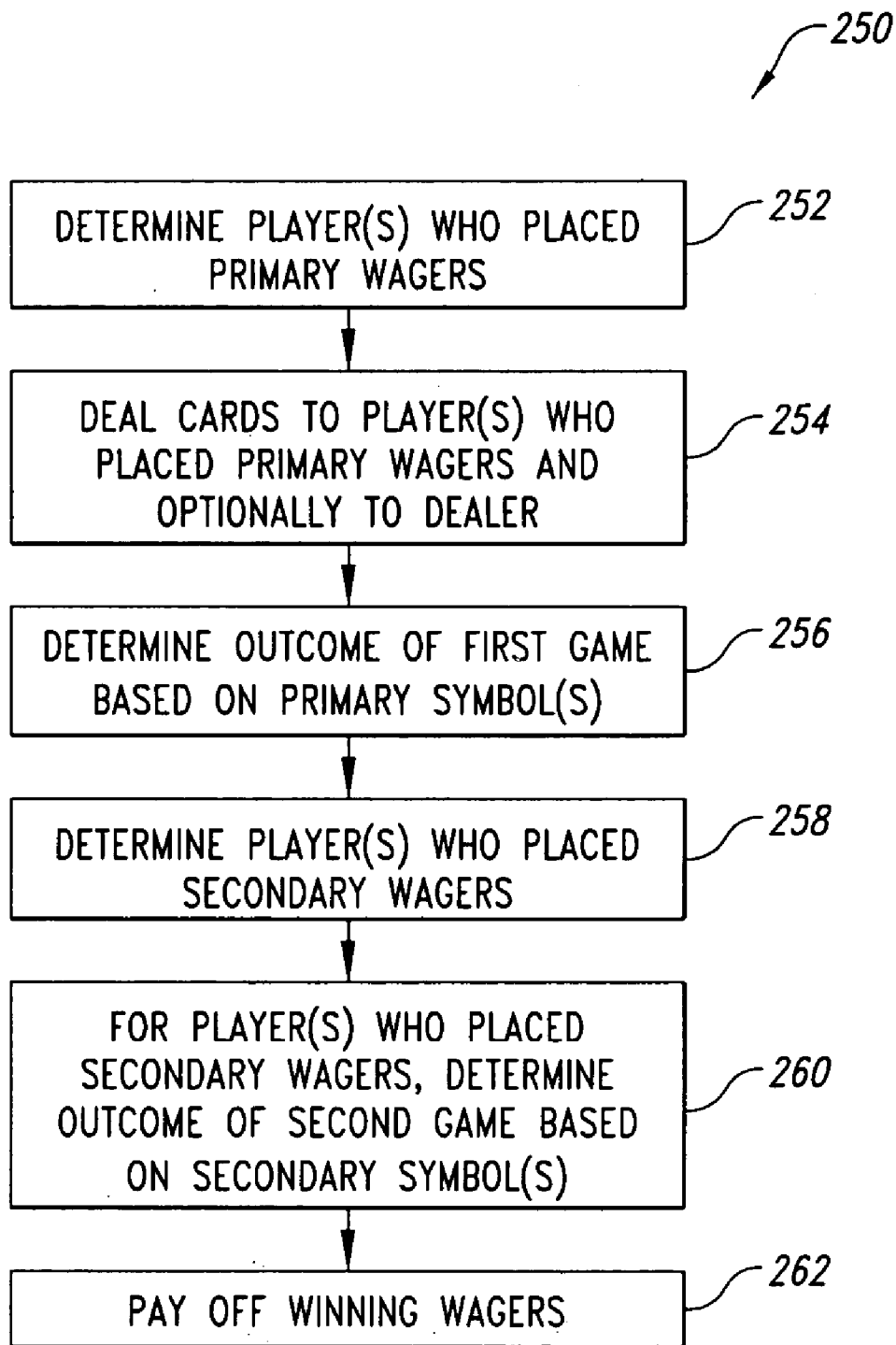


*FIG. 15*

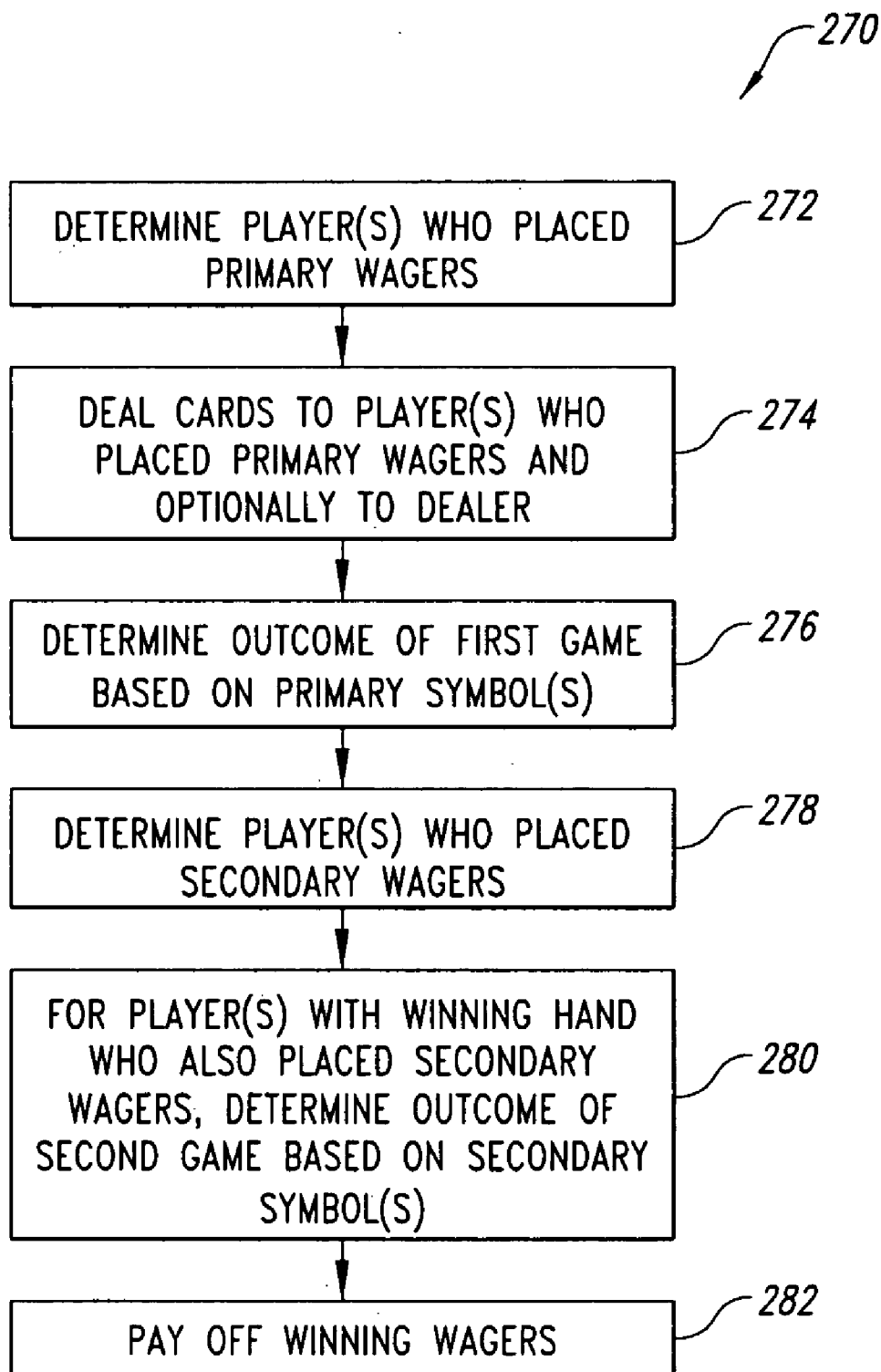


*FIG. 16*





*FIG. 17*



*FIG. 18*

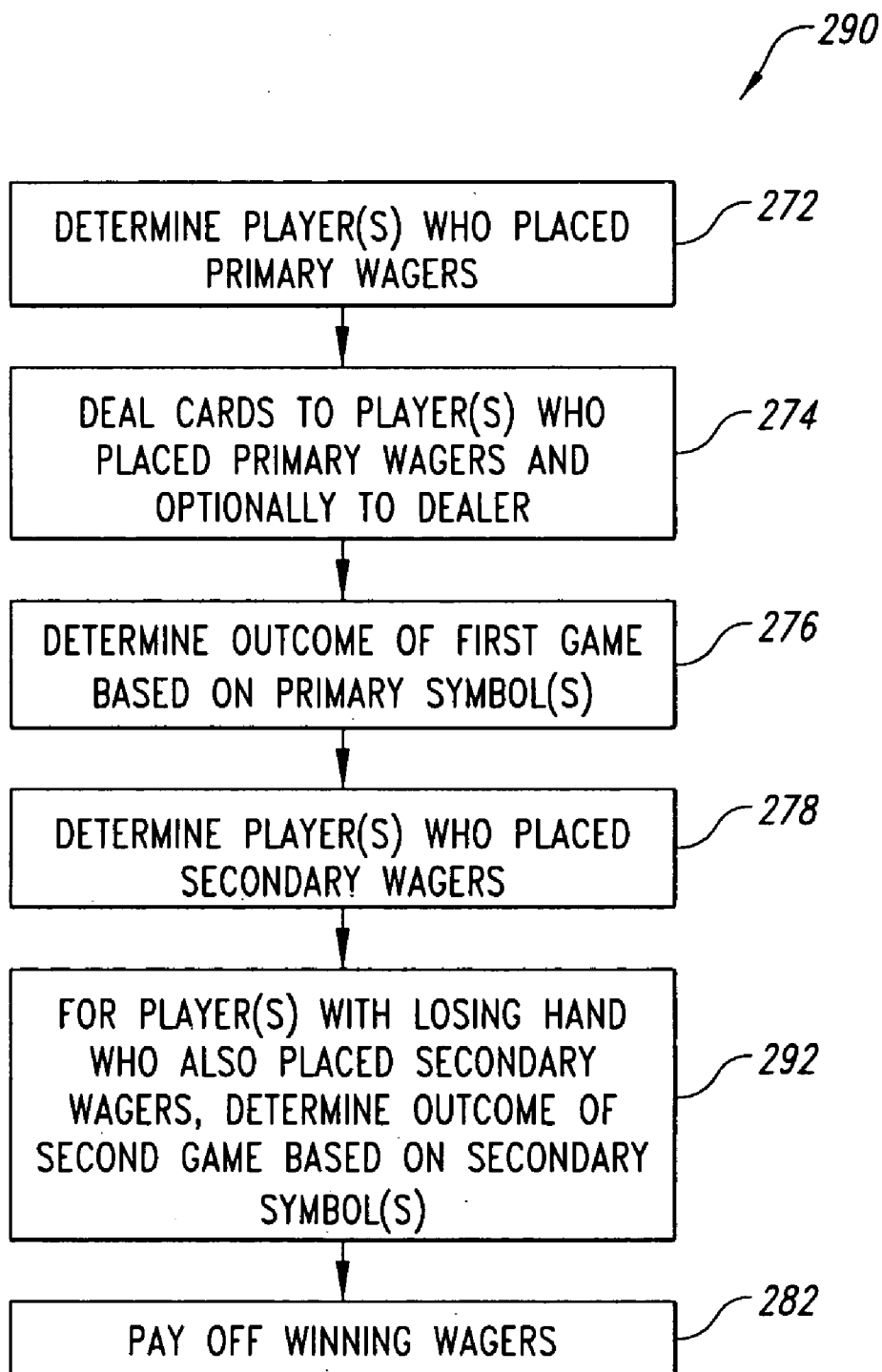


FIG. 19

## METHOD, APPARATUS AND ARTICLE FOR DUAL-SIDED PLAYING CARDS

### BACKGROUND OF THE INVENTION

#### [0001] 1. Field of the Invention

[0002] This invention is generally related to games of skill and chance, and in particular to a method, apparatus and article for playing a card game.

#### [0003] 2. Description of the Related Art

[0004] Card games are a well-known form of recreation and entertainment. Card games, especially wagering card games played in modern-day casinos, are more exciting and offer more entertainment value to the player when the games are quickly played for rapid wage resolution and the player is involved in decisions affecting the outcome of the game. The games are also more exciting to the player when there is more than one wagering opportunity during the course of the game, when there are multiple opportunities to win and/or when a substantial bonus or jackpot is involved, such as a progressive jackpots.

[0005] Wagering games which provide quick succession of play, more than one wagering opportunity, and more than one opportunity to win are all known. For example, for quick play, U.S. Pat. No. 5,154,429 to LeVasseur discloses a game where the dealer plays multiple hands against a single hand and thereby increases the number of hands that can be played in the same amount of time. For more than one wagering opportunity, U.S. Pat. No. 4,861,041 to Jones et al. discloses a method of wagering where the player makes an additional wager at the beginning of a hand. These additional wagers are accumulated as a progressive jackpot, which a player making the additional wager may win if the cards received match a predetermined arrangement of cards.

[0006] While the above-mentioned methods and devices are directed toward wagering games designed to engage the player and provide entertainment value, the entertainment industry has a continued need for new and exciting games which can be played out quickly, and provide more than one wagering opportunity and/or more than one opportunity to win.

### BRIEF SUMMARY OF THE INVENTION

[0007] In one aspect, a set of playing cards comprises a plurality of playing cards for wagering, each of the playing cards in the plurality of playing cards comprising: a first side; and a second side opposed to the first side; the first side bearing at least a first primary symbol, the first primary symbol selected from a first set of primary symbols, each of the first primary symbols in the first set of primary symbols indicative of a playing card identity according to a first set of game rules, the first set of game rules defining values of various combinations of the playing card identities; and the second side bearing at least a first secondary symbol, the first secondary symbol selected from a first set of secondary symbols, each of the first secondary symbols in the first set of secondary symbols indicative of a playing card identity according to a second set of game rules, the second set of game rules defining values of various combinations of the playing card identities.

[0008] In another aspect, a set of playing cards for wagering comprises, each of the playing cards: a first side bearing

at least a first primary symbol and a second primary symbol, the first primary symbol selected from a standard set of playing card rank symbols comprising 2, 3, 4, 5, 6, 7, 8, 9, 10, J, Q, K, and A, and the second primary symbol selected from a standard set of playing card suit symbols ♠, ♣, ♦, and ♠; and a second side bearing at least a first secondary symbol, the first secondary symbol on the second side selected from a first set of secondary symbols, each of the first secondary symbols in the first set of secondary symbols indicative of a playing card identity according to a set of game rules.

[0009] In another aspect, a method of producing playing cards having a face and a back, comprises: forming at least a first primary symbol on the face of the playing card, the first primary symbol from a first set of primary symbols and indicative of an identity of a playing card according to a first set of game rules, the first set of game rules defining values of various combinations of the playing card identities; pseudo-randomly generating at least a first secondary symbol from a first set of secondary symbols, each of the secondary symbols in the first set of secondary symbols indicative of a playing card identity according to a second set of game rules, the second set of game rules defining values of playing card identities; and forming the first secondary symbol on the back of the playing card.

[0010] In yet another aspect, a device for producing playing cards comprises: a housing; a media path extending through the housing along which playing card stock passes; at least a one printhead coupled to receive print data, the at least one printhead proximate the media path and operable to print on the playing card stock passing the printhead along the media path; and at least one processor configured to pseudo-randomly generate at least a number of first secondary identifiers, each of the first secondary identifiers corresponding to a respective first secondary symbol, the first secondary symbols being from a first set of secondary symbols, where the at least one processor is coupled to provide print data representing the first secondary symbols and representing at least a number of first primary symbols, the first primary symbols from a first set of primary symbols, the at least one processor configured to cause the printhead to print the first secondary symbol on a back of the playing card stock and to print the first primary symbol on a face of the playing card stock, where each of the primary symbols in the first set of primary symbols indicative of a playing card identity according to a first set of game rules, the first set of game rules defining values of various combinations of the playing card identities and each of the secondary symbols in the first set of secondary symbols indicative of a playing card identity according to a second set of game rules.

[0011] In still another aspect, a method of producing playing cards having a face and a back, the face bearing a first primary symbol from a first set of primary symbols and a second primary symbol from a second set of primary symbols, the first and the second primary symbols pre-printed on the face of the playing card and indicative of an identity of a playing card according to a first set of game rules, the first set of game rules defining values of various combinations of the playing card identities comprises pseudo-randomly generating at least a first secondary symbol from a first set of secondary symbols, each of the secondary symbols in the first set of secondary symbols

indicative of a playing card identity according to a second set of game rules, the second set of game rules defining values of playing card identities; and forming the first secondary symbol on the back of the playing card.

[0012] In yet still another aspect, a device for producing playing cards from preprinted playing card stock, the pre-printed playing card stock bearing a first and a second symbol selected from a standard set of playing card rank symbols and a standard set of playing card suit symbols, respectively, comprises: a housing; a media path extending through the housing along which the playing card stock passes; at least a one printhead coupled to receive print data, the at least one printhead proximate the media path and operable to print on the playing card stock passing the printhead along the media path; and at least one processor configured to pseudo-randomly generate at least a number of first secondary identifiers, each of the first secondary identifiers corresponding to a respective first secondary symbol, the first secondary symbols from a first set of secondary symbols, where the at least one processor is coupled to provide the print data representing the first secondary symbols to cause the printhead to print the first secondary symbols on a back of the playing card stock.

[0013] In a further aspect, a method of contemporaneously playing two card games with a dual-sided card deck comprises: dealing a number of playing cards to at least a first player, each playing card having at least a first primary symbol on a first side and at least a first secondary symbol on a second side, the first primary symbols from a first set of primary symbols and the first secondary symbols from a first set of secondary symbols; determining an outcome of a first game according to a first set of game rules based at least in part on the first primary symbol on the first side of at least one of the number of playing cards; and determining an outcome of a second game according to a second set of game rules based at least in part on the first secondary symbol on the second side of at least one of the number of playing cards.

[0014] In yet a further aspect, a method of playing a wagering game comprises: dealing a number of hands of playing cards to each of a number of players, each playing card having at least a first primary symbol on a first side and at least a first secondary symbol on a second side, the first primary symbols from a first set of primary symbols and the first secondary symbols from a first set of secondary symbols; determining an outcome of a first game according to a first set of game rules based at least in part on the first primary symbol on the first side of at least one of the number of playing cards of each hand; and for each of a number of winning hands determined based at least in part on the first primary symbol on the first side of at least one of the number of playing cards of each hand, determining an outcome of a second game according to a second set of game rules based at least in part on the first secondary symbol on the second side of at least one of the number of playing cards.

[0015] In still a further aspect, a method of playing a wagering game comprises: dealing a number of hands of playing cards to each of a number of players, each playing card having at least a first primary symbol on a first side and at least a first secondary symbol on a second side, the first primary symbols from a first set of primary symbols and the first secondary symbols from a first set of secondary sym-

bolis; determining an outcome of a first game according to a first set of game rules based at least in part on the first primary symbol on the first side of at least one of the number of playing cards of each hand; and for each of a number of losing hands, determining an outcome of a second game according to a second set of game rules based at least in part on the first secondary symbol on the second side of at least one of the number of playing cards.

[0016] In yet still a further aspect, a method of playing a card game comprises: for each of a number of players, determining if the player placed a primary wager; dealing a number of hands of playing cards to each of a number of players who placed a respective one of the primary wagers, each playing card having at least a first primary symbol on a first side and at least a first secondary symbol on a second side, the first primary symbols from a first set of primary symbols and the first secondary symbols from a first set of secondary symbols; determining an outcome of a first game according to a first set of game rules based at least in part on the first primary symbol on the first side of at least one of the number of playing cards of each hand; determining an outcome of a second game according to a second set of game rules based at least in part on the first secondary symbol on the second side of at least one of the number of playing cards; and for each of a number of winning hands, if any, determined based at least in part on the first secondary symbol on the second side of at least one of the number of playing cards of each hand, providing the player an award.

[0017] In even a further aspect, a method of playing a card game comprises: for each of a first number of players, determining if the player placed a primary wager; dealing a number of hands of playing cards to each of the players who placed a respective one of the primary wagers, each playing card having at least a first primary symbol on a first side and at least a first secondary symbol on a second side, the first primary symbols from a first set of primary symbols and the first secondary symbols from a first set of secondary symbols; determining an outcome of a first game according to a first set of game rules based at least in part on the first primary symbol on the first side of at least one of the number of playing cards of each hand; for each of a second number of players, determining if the player placed a secondary wager; and for each of the players who placed a secondary wager, determining an outcome of a second game according to a second set of game rules based at least in part on the first secondary symbol on the second side of at least one of the number of playing cards in the respective hand of playing cards.

[0018] In still even a further aspect, a device for producing playing cards comprises: means for pseudo-randomly generating at least a number of first secondary identifiers; means for associating the number of first secondary identifiers with respective ones of a number of first secondary symbol, the first secondary symbols from a first set of secondary symbols, each of the secondary symbols in the first set of secondary symbols indicative of a playing card identity according to one set of game rules; and means for printing the first secondary symbols on a back of a playing card stock where a face of the playing card stock bears a first and a second primary symbols, the first and the second primary symbols from a standard set of playing card ranks and a standard set of playing card suits, respectively.

#### BRIEF DESCRIPTION OF THE SEVERAL VIEWS OF THE DRAWINGS

[0019] In the drawings, identical reference numbers identify similar elements or acts. The sizes and relative positions of elements in the drawings are not necessarily drawn to scale. For example, the shapes of various elements and angles are not drawn to scale, and some of these elements are arbitrarily enlarged and positioned to improve drawing legibility. Further, the particular shapes of the elements as drawn, are not intended to convey any information regarding the actual shape of the particular elements, and have been solely selected for ease of recognition in the drawings.

[0020] FIG. 1 is an isometric view of a wagering environment such as a casino showing a gaming table for playing one or more card games.

[0021] FIG. 2 shows a number of playing cards bearing primary symbols for a first card game on a first side, and secondary symbols for a second card game on a second side.

[0022] FIG. 3 is a chart illustrating various symbols for use as primary and secondary symbols on the playing cards of FIG. 2.

[0023] FIGS. 4A and 4B are a diagrammatic illustration of a plurality of playing cards employing standard rank and suit markings on both the face and the back of the playing cards.

[0024] FIGS. 5A and 5B are a diagrammatic illustration of a set of playing cards employing standard rank and suit markings on the face of the playing cards and graphical symbols such as standard slot machine symbols on the back of each of the playing cards.

[0025] FIGS. 6A and 6B are a diagrammatic illustration of a plurality of playing cards employing standard rank and suit marking on the face of the playing cards and numerical symbols on the back of the playing cards.

[0026] FIGS. 7A and 7B are a diagrammatic illustration of a plurality of playing cards employing numeric symbols on the face of each playing card and graphical symbols on the back of each playing card.

[0027] FIG. 8 is a diagrammatic illustration of the back of three playing cards each bearing a graphical symbol, the graphical symbols forming a rebus.

[0028] FIG. 9 is a schematic diagram of a printer operable to print symbols on one side of the playing cards.

[0029] FIG. 10 is a schematic diagram of a printer operable to print primary and secondary symbols on both the face and the back of the playing card in a single pass.

[0030] FIG. 11 is a flow diagram of a method of forming playing cards including pseudo-randomly generating values corresponding to the secondary symbols to be formed on the back of the playing card.

[0031] FIG. 12 is a flow diagram of a method of forming playing cards including pseudo-randomly generating values corresponding to the primary symbols on the face of the playing and pseudo-randomly generating values corresponding to the secondary symbols on the back of the playing card.

[0032] FIG. 13 is a flow diagram of a method of forming playing cards including pseudo-randomly generating a value

corresponding to a secondary symbol to be formed on the back of the playing card carrying preprinted primary symbols on the face.

[0033] FIG. 14 is a flow diagram of a method of forming playing cards including pseudo-randomly generating values corresponding to the secondary symbols for the back of the playing cards based on values associated with primary symbols preprinted on the face of the playing cards.

[0034] FIG. 15 is a flow diagram of a method of playing a wagering game, including determining an outcome of a first game based on primary symbols carried on the face of the playing card and for each losing hand determining an outcome of a second game based on secondary symbols on the back of the playing card.

[0035] FIG. 16 is a flow diagram of a method of playing a wagering game including determining an outcome of a first game based on primary symbols carried on the face of the playing card and for each winning hand determining an outcome of a second game based on secondary symbols carried on the back of the playing card.

[0036] FIG. 17 is a flow diagram of a method of playing a card game, including determining an outcome of a first game based on primary symbols carried on the face of the playing card, and for players who place a secondary wager determining an outcome of a second game based on secondary symbols carried on the back of the playing card.

[0037] FIG. 18 is a flow diagram of a method of playing a wagering game, including determining an outcome of a first game based on primary symbols carried on the face of a playing card and for players with winning hands who have also placed secondary wagers, determining an outcome of a second game based on secondary symbols carried on the back of the playing card.

[0038] FIG. 19 is a flow diagram of a method of playing a wagering game, including determining an outcome of a first game based on primary symbols carried on a face of the playing card and for players with winning hands who also placed secondary wagers, determining an outcome of a second game based on secondary symbols carried on the back of the playing card.

#### DETAILED DESCRIPTION OF THE INVENTION

[0039] In the following description, certain specific details are set forth in order to provide a thorough understanding of various embodiments of the invention. However, one skilled in the art will understand that the invention may be practiced without these details. In other instances, well-known structures associated with playing cards, printers, processors, and gaming or wagering apparatus have not been shown or described in detail to avoid unnecessarily obscuring descriptions of the embodiments of the invention.

[0040] Unless the context requires otherwise, throughout the specification and claims which follow, the word “comprise” and variations thereof, such as, “comprises” and “comprising” are to be construed in an open, inclusive sense, that is as “including, but not limited to.”

[0041] The headings provided herein are for convenience only and do not interpret the scope or meaning of the claimed invention.

[0042] Gaming Environment

[0043] FIG. 1 shows a card game, such as blackjack, being played at a gaming table 10 by a game operator or dealer 12 employed by a gaming house or casino and customers or players 14, 16. While blackjack is used as an example, the teachings herein are generally applicable to a variety of card games, such as baccarat or poker, to name only a few.

[0044] During a game, the dealer 12 removes playing cards 18 from a card shoe 20. The dealer 12 can individually draw the playing cards 18 from the card shoe 20, or can remove a number of the playing cards 18 from the card shoe 20 to deal by hand. Many players 14, 16 appreciate the experience of a game where the playing cards 18 are dealt from a handheld deck of playing cards 18, rather than being individually drawn or produced from the card shoe 20.

[0045] The players 14, 16 place their respective wagers by placing a number of chips 22 in wager circles 24 demarcated on a playing surface 26 of the gaming table 10. The chips 22 typically come in a variety of denominations, as is explained in detail below. Players 14, 16 are issued chips in exchange for currency or credit by the casino's tellers. Casinos typically require the use of chips 22 for wagering, rather than actual currency. In some games, a player 14 may choose to play multiple hands by placing more than one wager, as illustrated in FIG. 1. The players 14, 16 will often have a reserve of chips 28 from which to place wagers. In some aspects, secondary wager circles 29 may be demarcated on the playing surface 26, for playing secondary or bonus wagers 31. The secondary wager 31 would be in addition to the primary wager 22 played in wager circles 24, and may correspond to a wager on a second game, progressive jackpot or other type of bonus wager, as described in detail below.

[0046] In blackjack, after the players 14, 16 have placed an initial wager of chips 22 in their respective wager circles 24, 29, the dealer 12 deals each player two cards 30 face down and deals themselves one card 32 face down ("hold card") and one card 34 face up ("show card") from the deck 18. In some casinos, the playing cards 30 dealt to the players 14, 16 are also dealt face up. The players 14, 16 can accept additional cards ("hits") from the deck 18 as they attempt to reach a total card value of 21 without going over, where face cards count as 10 points, and Aces can count as either one or 11 points, at the card holder's option. The dealer 12 also attempts to reach 21 without going over, although the rules typically require the dealer to take a hit when holding a soft 17. The players 14, 16 can vary their wagers (i.e., chips 22 and/or 31) after the initial cards 30, 34 are dealt based on their knowledge of their own hand and the dealer's face up card 34. For example, the players 14, 16 can "hit" or "stand" and may "double down" or "buy insurance."

[0047] At the end of a hand or game, the dealer 12 collects the wager chips 22 from losing players and pays out winnings in chips to the winning players. The winnings are calculated as a multiple of a set of odds for the game and the amount of the wager chips 22. The losses are typically the amount of the wager chips 22, 31. The dealer 12 places the collected wager chips 22 or "take" from the losing hands into a gaming table bank that takes the form of a chip tray 36. The dealer 12 pays out the winning hands using the required number of chips 38 from the chip tray 36. The chip

tray 36 generally consists of a number of wells, sized to receive the chips 38 with different wells generally used to contain different value chips. Changes to the contents of the chip tray 36 represent the winnings and losses of the casino ("house") at the gaming table 10. Many casinos permit the dealer 12 to exchange chips for items 40 of value, such as currency or other items at the gaming table 10. The dealer 12 deposits the item of value 40 into a drop box 42 at or near the gaming table 10. Periodically, for example at the end of a dealer's shift, the contents of the drop box 42 must be reconciled with the contents of the chip tray 36, to ascertain that the correct number and value of chips were distributed.

[0048] Dual Sided Playing Cards

[0049] FIG. 2 shows a set of playing cards 18 including an individual playing card 44 having a first side or face 44a and a second side or face 44b. As used herein, first side or face 44a refers to a surface of the playing card 44 carrying primary symbols used in a primary or first game, while second side or back refers to a surface of the playing card 44 carrying secondary symbols used in a secondary or second game.

[0050] As illustrated in FIG. 2, the face 44a of the playing card 44 carries a first primary symbol (i.e., K) 46 and a second primary symbol (i.e., ♥) 48. In this embodiment, the first primary symbol 46 is selected from a first set of primary symbols constituting standard playing card rank symbols (i.e., 2-10, J, Q, K, A). Also in this embodiment, the second primary symbol 48 is selected from a second set of primary symbols consisting of standard playing card suit symbols (i.e., ♥, ♦, ♠, ♣).

[0051] Also as illustrated in FIG. 2, the back 44b of the playing card 44 includes at least a first secondary symbol 50. In this embodiment, the first secondary symbol 50 is selected from a first set of secondary symbols, for example, a set comprising all or a portion of standard slot machine symbols (e.g., cherry, bar, bell, star, lemon).

[0052] Various Suitable Symbols

[0053] FIG. 3 shows some examples of suitable symbols for use on the face 44a and/or back 44b of each of the playing cards 44 of the playing card set 18. The first and second, primary and secondary symbols may take the form of standard playing card rank symbols, such as illustrated in row 52 and/or standard playing card suit symbols such as illustrated in row 54. The first and second primary and secondary symbols may take the form of pictorial or graphic symbols such as illustrated in row 56, numerical symbols such as illustrated in row 58, and/or text symbols such as illustrated in row 60. The graphic and/or text symbols may indicate a particular good, service or other prize to be awarded, and/or may form a portion of a puzzle to be solved. For example, the graphic or text symbols may form a rebus or a riddle to be solved, the answer to the rebus or riddle identifying the prize to be won. The first and second primary and secondary symbols may take the form of color symbols such as illustrated in row 62 and/or amount symbols such as illustrated in row 64. The amount symbols may indicate an amount to be awarded, or an amount by which some other winning amount will be multiplied or enhanced. In some aspects, these symbols may be employed in matching games, for example games require the identical matching of two or more symbols, or the combination of various symbols to achieve a desired result, as is explained in detail below.

[0054] FIGS. 4A and 4B show a set of playing cards 18 according to one illustrated embodiment, in this illustration consisting of 52 playing cards. Other embodiment may use a greater or less number of playing cards 44 in the set of playing cards 18. The playing cards 18 are organized into rows of like suit and columns of like rank for ease of presentation. The individual playing cards 44 in FIG. 4B are arranged in the same order as in FIG. 4A. Thus, FIGS. 4A and 4B illustrate a mapping between the face 44a and the backs 44b of the playing cards 44 forming the set of playing cards 18.

[0055] In particular, FIG. 4A shows the face 44a of each playing card 44 in the set of playing cards 18. The face 44a of each playing card 44 bears a first primary symbol 46 and a second primary symbol 48. The first primary symbols 46 are selected from a first set of primary symbols, such as a set of standard playing card rank symbols. The second primary symbols 48 are selected from a second set of primary symbols such as a set of standard playing card suit symbols. Thus, the set of playing cards 18 form a standard deck of playing cards based on the primary symbols 46, 48.

[0056] FIG. 4B shows the backs 44b of each playing card 44 in the set of playing cards 18. The back 44b of each playing card 44 bears a first and second secondary symbol, 50, 66. The first and the second secondary symbols 50, 66 also take the form of standard playing card rank and suit symbols, respectively, to form a standard deck of playing cards based on primary symbols 46, 48.

[0057] The mapping illustrated in FIGS. 4A and 4B is not absolute. As will become apparent, it is advantageous to vary the relationship between the primary symbol(s) 46, 48 appearing on the faces 44a and secondary symbol(s) 50, 66 appearing on the backs 44b such that the secondary symbol(s) 50, 66 are not discernible to the players 14, 16 from a knowledge of the primary symbol(s) 46, 48. Thus, while a player 14, 16 may know the value or identity of the playing card 44 as defined by the primary symbol(s) 46, 48 on the face 44a of the playing card 44, the player 14, 16 does not know and cannot discern the value or identity of the playing card 44 as defined by the secondary symbol(s) 50, 66 on the back 44b of the playing card 44.

[0058] FIGS. 5A and 5B show a set of playing cards 18 according to a second illustrated embodiment, in this illustration consisting of 52 playing cards. Again, the playing cards 18 are organized into rows of like suit and columns of like rank for ease of presentation, and the individual playing cards 44 in FIG. 5B are arranged in the same order as in FIG. 5A. Thus, FIGS. 5A and 5B illustrate a mapping between the face 44a and the backs 44b of the playing cards 44 forming the set of playing cards 18.

[0059] In particular, FIG. 5A shows the face 44a of each playing card 44 in the set of playing cards 18. The face 44a of each playing card 44 bears a first primary symbol 46 and a second primary symbol 48. The first primary symbols 46 are select from a first set of primary symbols, such as a set of standard playing card rank symbols. The second primary symbols 48 are selected from a second set of primary symbols such as a set of standard playing card suit symbols. Thus, the set of playing cards 18 form a standard deck of playing cards based on the primary symbols 46, 48.

[0060] FIG. 5B shows the backs 44b of each of the playing cards 44 in the set of playing cards 18. The back 44b

of each playing card 44 bears a first secondary symbol 50. The first secondary symbol 50 takes the form of a graphic symbol selected from a first set of secondary symbols set such as all or some of a set of standard slot machine symbols (e.g., cherry, bell, star, lemon, bar, double bar). In this embodiment, a winning hand of playing cards may be formed by matching a number of the secondary symbols 50 in a similar fashion as employed in slot machine games.

[0061] FIGS. 6A and 6B show a set of playing cards 19 according to another illustrated embodiment. Again, the playing cards 18 are organized into rows of like suit and columns of like rank for ease of presentation, and the individual playing cards 44 in FIG. 6B are arranged in the same order as in FIG. 5A. Thus, FIGS. 6A and 6B illustrate a mapping between the face 44a and the backs 44b of the playing cards 44 forming the set of playing cards 18.

[0062] In particular, FIG. 6A shows the face 44a of each playing card 44 in the set of playing cards 18. The face 44a bears a first primary symbol 46 and a second primary symbol 48. The first primary symbols 46 are select from a first set of primary symbols, such as a set of standard playing card rank symbols. The second primary symbols 48 are selected from a second set of primary symbols such as a set of standard playing card suit symbols. Thus, the set of playing cards 18 form a standard deck of playing cards based on the primary symbols 46, 48.

[0063] FIG. 6B shows the backs 44b of each of the playing cards in the set of playing cards 18. The back 44b of each playing card 44 bears a first secondary symbol 50. The first secondary symbol 50 is selected from a first set of secondary symbols, for example a set of numeric symbols such as integers (e.g., 5, 10, 20). As discussed further below, these numeric secondary symbols may be employed in games that require matching of the numeric symbols, the summing of the numeric symbols, an amount by which an award amount is multiplied or may otherwise indicate an award.

[0064] FIGS. 7A and 7B a set of playing cards 18 according to a second illustrated embodiment, in this illustration consisting of 52 playing cards. Again, the individual playing cards 44 in FIG. 5B are arranged in the same order as in FIG. 5A. Thus, FIGS. 5A and 5B illustrate a mapping between the face 44a and the backs 44b of the playing cards 44 forming the set of playing cards 18.

[0065] In particular, FIG. 7A shows the face 44a of each playing card in the set of playing cards 18. The face 44a of each playing card 44 bears a first primary symbol 46. The first primary symbol 46 is selected from a first set of primary symbols, for example, a set of numeric symbols such as integers (e.g., 5, 10, 20). These numeric secondary symbols may be employed in games that require matching of the numeric symbols, the summing of the numeric symbols, a amount by which an award amount is multiplied or may otherwise indicate an award.

[0066] FIG. 7B shows the backs 44b of each of the playing cards 44 in the set of playing cards 18. The back 44b of each playing card 44 bears a first secondary symbol 50. The first secondary symbol 50 is selected from a first set of secondary symbols, for example a set of graphic symbols, text symbols, color symbols, and/or amount symbols. As discussed herein, these secondary symbols may be



employed in games that require matching of the symbols, the collection of symbols to match a defined combination, the summing of the symbols to achieve a defined total, and/or the solution of a rebus or puzzle. These secondary symbols may additionally, or alternatively indicate an award, an amount of an award, an amount by which an award amount is multiplied or may otherwise indicate an award or prize.

[0067] FIG. 8 shows the backs 44b of three playing cards 44, each of the playing cards 44 bearing a first secondary symbol 50 in the form of a graphical symbol. The graphical symbols form a rebus (i.e., representation of words in the form pictures or symbols) for solution by the player 14, 16. As illustrated, the first secondary symbols 50 represent an eye, a heart and a ewe, which the player may solve as the phrase "I love you." The player cards 44 may employ other symbols to form additional or alternative rebus, and may employ text symbols to form riddles or other puzzles.

[0068] Thus, the above described embodiments permit a player to play a first card game, for example blackjack, while a second card game is simultaneously occurring. The illustrated embodiments are intended to be representative, and one skilled in the art will recognize that various aspects from the different embodiments can be combined or replaced by various aspects of other embodiments. Further, playing cards 44 may employ symbols other than those illustrated.

[0069] Typically, the player 14, 16 will make decision (e.g., hit or stay) based on the primary symbols 46, 48 to achieve a winning outcome (e.g., hand with a total value close to twenty-one without going over) in a first game (e.g., blackjack) played according to a first set of rules. The player 14, 16 may make the decision in the first game independently of the secondary symbols or the rules of a second game. Alternatively, the player 14, 16 may at the same time, base the decision in the first game on a desired outcome in the second game. For example, the player 14, 16 may hold a hand having primary symbols totaling a value 17. While the player 14, 16 holding such a hand would strongly consider not accepting further playing cards, the probability of improving a hand formed by the secondary symbols may cause the player 14, 16 to take an additional playing card. For example, where the secondary symbols are standard slot machine symbols, an additional playing card may significantly increase the odds of forming a hand having two or more matching secondary symbols, and/or may increase the odds of winning an enhanced or bonus prize or award.

[0070] Devices For Forming Dual Sided Playing Cards

[0071] FIG. 9 shows a device 70 for forming the playing cards 44 of the set of playing cards according to one embodiment. The device 70 may be located at a playing card manufacturing facility remote from the casino, or remote from the gaming floor of the casino. Alternatively, the device 70 may be located at the casino, either in an area closed to patrons or on the gaming floor, such as positioned on the gaming table 10 (FIG. 1) in the form of the card shoe 20. Where located on the gaming table 10, the device 70 may dispense playing cards 44 in real time, which are dealt to the players 14, 16 by the dealer 12. The device 70 comprising a housing 72, a media path 74 defined through at least a portion of the housing 72 along which media such as playing cards or playing card stock 76 passes. As illustrated in FIG. 9, the playing card stock 76 may take the form of a plurality of individual playing card blanks. The device 70 includes a

controller, such as a microprocessor 78, coupled to control a printhead 80, for example via a print controller 82, to print on the playing card stock 76. The microprocessor 78 is also coupled to control a motor 84, such as a stepper motor, for example via a motor controller 86. The motor 84 is coupled to drive a platen 88 for advancing the playing card stock 76 along the media path 74.

[0072] The microprocessor 78 may receive instructions and/or data from one or more memories such as random access memory (RAM) 90 and/or read-only memory (ROM) 92. One or both of the memories 90, 92 may store print data corresponding instructions for controlling the printhead 80 to print primary and/or secondary symbols. The printhead 80 can take any of a variety of forms including thermal printhead, inkjet printhead, impact printhead, or laser printhead.

[0073] The microprocessor 78 is programmed to generate at least one secondary identifier for each playing card 44, where the secondary identifier identifies at least one of a set of secondary symbols.

[0074] The pseudorandom generation of secondary identifiers and hence the pseudorandom generation of the secondary symbol(s) 50, 66 may be independent of the primary symbol(s) 46, 48 to be printed on or previously printed on the face 44a of the card stock 76. For example, the microprocessor 78 may employ a seed value that is unrelated to the primary symbol(s) 46, 48 in a standard pseudo-random number generation algorithm.

[0075] Alternatively, the pseudo-random generation of secondary identifiers and hence the pseudorandom generation of the secondary symbol(s) 50, 66 may be dependent on the primary symbol(s) 46, 48 to be printed on or previously printed on the face 44a of the card stock 76. For example, the microprocessor 78 may employ a seed value that is related to the primary identifier and/or primary symbol(s) 46, 48 in a standard pseudo-random number generation algorithm.

[0076] Additionally, or alternatively, the pseudo-random number generation algorithm may be weighted based on the seed value. The weighting may increase the likelihood of pseudo-randomly selecting a "high" value secondary symbol 50, 66 (e.g., cherry or high value ranks such as 10, J, Q, K, A) where the primary symbol has a "low" value (e.g., low value ranks such as 2-6). Likewise, the weighting may decrease the likelihood of pseudo-randomly selecting a "high" value secondary symbol 50, 66 (e.g., cherry or high value ranks such as 10, J, Q, K, A) where the primary symbol has a "high" value (e.g., high value ranks such as 10, J, Q, K, A). The weighting may be obtained by varying the probability or size of the set for particular seed values. For example, the pseudo-random number generation algorithm may define a 1 in 100 chance of generating a secondary identifier corresponding to a cherry for seed values associated with high value primary identifiers, and a 1 in 20 chance of generating a secondary identifier corresponding to a cherry for seed values associated with low value primary identifiers. The pseudo-random number generation algorithm may be defined to produce pairings of primary and secondary identifiers based on a combined probability of a player winning one game, the other game or both games.

[0077] Thus, the microprocessor 78 may pseudo-randomly generate an secondary identifier corresponding to one

of the standard playing card rank and/or suit symbols, graphical symbols, numerical symbols, text symbols, color symbols and/or amount symbols previously discussed.

[0078] The device 70 may optionally include a sensor 94 for automatically reading markings identifying the primary symbol(s) 46, 48. The sensor may be an optical or magnetic sensor. For example, the sensor 94 may be an optical scanner or imager. The sensor 94 may sense the primary symbols 46, 48, or may sense some other symbol that indicative of the primary symbols 46, 48. For example, the sensor 94 may take the form of a barcode reader to read barcode carried by each card. The barcodes may encode the identity of the playing card 44 and/or primary symbols 46, 48, or may encode an identifier such as a unique serial number from which the identity of the playing card 44 may be determined, for example via a lookup table or algorithm.

[0079] The device 10 of FIG. 9 is particularly suitable where the playing cards 18 include one or more primary symbols 46, 48 preprinted on the face 44a, or where the playing cards pass through the device 70 twice, once face up and the other time face down.

[0080] FIG. 10 shows an alternative embodiment of the device 70. This alternative embodiment, and those alternative embodiments and other alternatives described herein, are substantially similar to previously described embodiments, and common acts and structures are identified by the same reference numbers. Only significant differences in the operation and structure are described below.

[0081] The device 70 of FIG. 10 includes at least a second printhead 96 positioned across the media path 74 with respect to the first printhead 80, for printing on a face 44a of the playing card stock 76 in a single pass. The microprocessor 78, or an alternative or additional microprocessor (not shown) controls the second printhead 96 via a second print controller 98 to print one or more primary symbols 46, 48 on the face 44a of the playing card stock 76. As illustrated in FIG. 10, the playing card stock 76 may be provided in the form of a roll. A platen 99, which may be driven or undriven, is opposed from the second printhead 96 to provide a substantially smooth flat surface for printing.

[0082] While discussed in terms of a printhead and printing, the device 70 may take any form of device suitable for forming visual images on the playing card stock 76, including but not limited to devices employing GYRICON™ technology developed by Xerox PARC of Palo Alto, Calif. and/or leucodye thermochromic inks.

[0083] Methods of Producing Dual Sided Playing Cards

[0084] FIG. 11 shows a method 100 of operating the device 70 of FIG. 10 according to a one illustrated embodiment. In step 102, the microprocessor 78 pseudo-randomly generates at least one secondary identifier per playing card 44.

[0085] As used herein the "identifier" is a value, typically a numeric value, that identifies the playing card. Employing a numeric identifier is particular useful where the identifiers a computer or microprocessor 78 will pseudo-randomly generate the identifier via standard pseudo-random number generation algorithms. Random number generation on computers is well known in the computing arts. Mathematicians do not generally consider computer generated random num-

bers to be truly random, and thus commonly refer to such numbers as being pseudo-random. However such numbers are sufficiently random for most practical purposes, such as distributing playing cards to players. Hence, while we denominate the computer generated identifiers as being pseudo-random, such term as used herein and in the claims should include any identifiers having a suitable random distribution, whether truly mathematically random or not.

[0086] The identifier is mapped to one or more symbols which are recognized by humans. For example, the identifier may be one of fifty-two numbers (e.g., 0-51) and may be mapped to the fifty-two combinations of rank and suit symbols of a standard set of playing cards. Thus, the microprocessor 78 may, for example, generate a single identifier that maps to more than one symbols (e.g., the numeric identifier 1 indicates the two of diamonds), or may generate identifiers that map to individual symbols (e.g., the numeric identifier 1 indicates a rank of two and the numeric identifier 52 indicates the suit of diamonds).

[0087] In step 104, the microprocessor 78 associates the secondary identifier(s) to print data stored in memories 90, 92 representing corresponding secondary symbol(s) 50, 66. In step 106, the microprocessor 78 provides print data representing secondary symbol(s) 50, 66 and primary symbol(s) 46, 48 to the printheads 80, 96, respectively. In step 108, the printhead 80 prints at least one secondary symbol 50, 66 on the back 44b of the playing card stock 76. In step 110, the printhead 96 prints at least one primary symbol 46, 48 on the face 44a of the playing card stock 76. Thus, the primary and secondary symbols 46, 48, 50, 66 are formed on the respective playing cards 44 in a single pass.

[0088] FIG. 12 shows a method 120 of operating the device 70 of FIG. 10 according to another illustrated embodiment. In step 122, the microprocessor 78 pseudo-randomly generates at least one primary identifier for each playing card 44. In step 124, the microprocessor 78 associates the primary identifier(s) to print data stored in memories 90, 92 representing corresponding primary symbol(s) 46, 48. In step 126, the microprocessor 78 pseudo-randomly generates at least one secondary identifier for each playing card 44 based at least in part on the primary identifier(s). In step 128, the microprocessor 78 associates the secondary identifier(s) to print data stored in memories 90, 92 representing corresponding secondary symbol(s) 50, 66. In step 130, the microprocessor 78 provides print data for the secondary and primary symbols 50, 66, 46, 48 to the printheads 80, 94, respectively. In step 132, the second printhead 96 prints at least one primary symbol 46, 48 on the face 44a of each playing card 44. In step 134, the first printhead 80 prints at least one secondary symbol 50, 66 on the back 44b of each playing card 44. Thus, the primary and secondary symbols 46, 48, 50, 66 are formed on the respective playing cards 44 in a single pass, and the secondary symbol(s) 50, 66 are dependent on the primary symbol(s) 46, 48.

[0089] FIG. 13 shows a method 150 of operating the device 70 of FIG. 9 according to one illustrated embodiment. In step 152, the device 70 receives playing cards 44 with one or more primary symbols 46, 48 preprinted on the face 44a of each playing card 44. In step 154, the microprocessor 78 pseudo-randomly generates at least one secondary identifier per playing card 44. In step 156, the microprocessor 78 associates the secondary identifier(s) to

print data stored in memories 90, 92 representing corresponding secondary symbol(s) 50, 66. In step 158, the microprocessor 78 provides print data to the printhead 80 via the print controller 82. In step 160, the printhead 80 prints at least one secondary symbol 50, 66 on the back 44b of each playing card 44. Thus, the device 70 forms secondary symbols 50, 66 on playing cards 44 in a single pass independently of the primary symbol(s) 46, 48.

[0090] In an alternative method, the device 70 of FIG. 9 may employ blank playing card stock 76 or playing card stock without any previous formed primary symbols 46, 48. In such an alternative, the device 70 may form one or more primary symbol(s) 46, 48 on the face 44a of the playing cards 44 in an additional pass, either before or after forming the secondary symbol(s) 50, 66.

[0091] FIG. 14 shows a method 170 of operating the device 70 of FIG. 9 according to another illustrated embodiment. In step 172, the device 70 receives playing card stock 76 with one or more primary symbol(s) 46, 48 preprinted on the face of each playing card. In step 174, the microprocessor 78 determines primary identifier(s) associated with the primary symbol(s) 46, 48. In step 176, the microprocessor 78 pseudo-randomly generates at least one secondary identifier per playing card 44 based at least in part on the determined primary identifier(s). In step 178, the microprocessor 78 associates the secondary identifier(s) to print data stored in memories 90, 92 representing corresponding secondary symbol(s) 50, 66. In step 180, the microprocessor 78 provides the print data to the printhead 80 via the print controller 82. In step 182, the printhead 80 prints at least one secondary symbol 50, 56 on the back 44b of each playing card 44.

[0092] Game Playing Employing Dual Sided Playing Cards

[0093] FIG. 15 shows a method 200 of playing a wagering game according to one illustrated embodiment. In step 202, the dealer 12 determines the players 14, 16 who have placed a primary wager 22. In step 204, the dealer 12 deals cards to the players 14, 16 who place primary wagers 22 and optionally to the dealer's own self. In step 206, the dealer 12 determines the outcome of a first game based on one or more of the primary symbol(s) 46, 48 according to a first set of game rules. In step 208, the dealer 12 pays off winning hands of the first game.

[0094] In step 210, for each losing hand, the dealer 12 determines an outcome of the second game based on one or more of the secondary symbol(s) 50, 66 according to a second set of game rules. The rules of the second game may be the same as the rules of the first game, for example, where both games are blackjack and the set of cards are similar to that shown in FIGS. 4A and 4B. Alternatively, the rules of the second game may be the different from the rules of the first game, for example, where one game is blackjack, the second game is a matching game, and the set of cards are similar to that shown in FIGS. 5A, 5B, 6A, 6B, 7A, and 7B.

[0095] In step 212, the dealer 12 pays off winning hands of the second game.

[0096] FIG. 16 shows a method 220 of playing a wagering game according to another illustrated embodiment. In step 222, the dealer 12 determines the players 14, 16 who have placed primary wagers 22. In step 224, the dealer 12 deals

cards to the players 14, 16 who have placed primary wagers 22 and optionally to the dealer's own self. In step 226, the dealer determines an outcome of a first game based on the primary symbol(s) 46, 48.

[0097] In step 228, for each winning hand, the dealer 12 determines an outcome of a second game based on secondary symbol(s) 50, 66. In step 230, the dealer 12 pays off the hands which won only the first game at a base payout, and pays off the hands which won both the first and the second games at an enhanced payout. The enhanced payout may, for example, be some multiple of the base payout, or may be some defined bonus or an amount based on an aggregation based on progressive wagering system.

[0098] FIG. 17 shows a method 250 of playing a wagering game according to yet another illustrated embodiment. In step 252, the dealer 12 determines the players 14, 16 who have placed primary wagers 22. In step 254, the dealer 12 deals cards to players 14, 16 who have placed the primary wager 22, and optionally to the dealer's own self. In step 256, the dealer 12 determines an outcome of a first game based on the primary symbol(s) 46, 48.

[0099] In step 258, the dealer 12 determines the players 14, 16 who have placed a secondary wager 31. In step 260, for each player 14, 16 who placed secondary wagers 31, the dealer 12 determines an outcome of a second game based on secondary symbol(s) 50, 66. In step 262, the dealer 12 pays off winning wagers. The pay off of winning wagers may include paying of winning wagers on each of the first and second games independently, or paying off the wagers based on a combination of the outcomes of the games for any given hand. For example, hands that win both the first and second games may receive an enhanced payout as discussed above.

[0100] FIG. 18 shows a method 270 of playing a wagering game according to yet another illustrated embodiment. In step 272, the dealer 12 determines the players 14, 16 who have placed primary wagers 22. In step 274, the dealer 12 deals cards to the players 14, 16 who have placed the primary wagers 22 and optionally to the dealer's own self. In step 276, the dealer 12 determines the outcome of a first game based on the primary symbol(s) 46, 48.

[0101] In step 278, the dealer 12 determines the players 14, 16 who have placed secondary wagers 31. In step 280, for players with winning hands in the first game who have also placed secondary wagers, the dealer 12 determines an outcome of the second game based on the secondary symbol(s) 50, 66. In step 282, the dealer 12 pays off winning wagers, as discussed above.

[0102] FIG. 19 shows a method 290 of playing a wagering game according to still a further illustrated embodiment. The method 290 is similar in many respects to the method of 280, and thus common acts are identified by the same reference numbers. The method 290 replaces step 280 of method 270 with step 292. In step 292, for players with losing hands who also placed secondary wagers, the dealer 12 determines an outcome of a second game based on the secondary symbol(s) 50, 66. Thus, the method 290 allows players 14, 16 who have lost a first game to have a chance at winning a second game.

[0103] Although specific embodiments of and examples for the dual-sided card game method, apparatus and article are described herein for illustrative purposes, various

equivalent modifications can be made without departing from the spirit and scope of the invention, as will be recognized by those skilled in the relevant art. The teachings provided herein of the invention can be applied to other card games, not necessarily the exemplary blackjack card game generally described above. The teachings can be applied to devices for forming symbols on playing cards other than printers. The device may employ any of a variety of algorithms for pseudo-randomly generating symbols. The pseudo-randomly generation of the secondary symbols may be either independent of, or dependent on the primary symbols as suits the particular application.

[0104] The various embodiments described above can be combined to provide further embodiments. All of the U.S. patents, U.S. patent application publications, U.S. patent applications, foreign patents, foreign patent applications and non-patent publications referred to in this specification and/or listed in the Application Data Sheet, including but not limited to U.S. Provisional Application Ser. No. 60/296,866, filed Jun. 8, 2001, and entitled "METHOD, APPARATUS AND ARTICLE FOR RANDOM SEQUENCE GENERATION AND PLAYING CARD DISTRIBUTION"; U.S. patent application Ser. No. 10/017,276, filed Dec. 13, 2001, and entitled "METHOD, APPARATUS AND ARTICLE FOR RANDOM SEQUENCE GENERATION AND PLAYING CARD DISTRIBUTION"; and U.S. Pat. No. 6,638,161, issued Oct. 28, 2003, and entitled "METHOD, APPARATUS AND ARTICLE FOR VERIFYING CARD GAMES, SUCH AS PLAYING CARD DISTRIBUTION", are incorporated herein by reference, in their entirety. Aspects of the invention can be modified, if necessary, to employ systems, circuits and concepts of the various patents, applications and publications to provide yet further embodiments of the invention.

[0105] These and other changes can be made to the invention in light of the above-detailed description. In general, in the following claims, the terms used should not be construed to limit the invention to the specific embodiments disclosed in the specification and the claims, but should be construed to include all playing cards; cards games, and/or devices for forming or dispensing dual-sided playing cards that operated in accordance with the claims. Accordingly, the invention is not limited by the disclosure, but instead its scope is to be determined entirely by the following claims.

1. A plurality of playing cards for wagering, each of the playing cards in the plurality of playing cards comprising:

a first side; and

a second side opposed to, the first side;

the first side bearing at least a first primary symbol, the first primary symbol selected from a first set of primary symbols, each of the first primary symbols in the first set of primary symbols indicative of a playing card identity according to a first set of game rules, the first set of game rules defining values of various combinations of the playing card identities; and

the second side bearing at least a first secondary symbol, the first secondary symbol selected from a first set of secondary symbols, each of the first secondary symbols in the first set of secondary symbols indicative of a playing card identity according to a second set of game

rules, the second set of game rules defining values of various combinations of the playing card identities independently of the first primary symbols.

2. The plurality of playing cards according to claim 1 wherein the first set of secondary symbols is different than the first set of primary symbols.

3. The plurality of playing cards according to claim 1 wherein the first set of secondary symbols is identical to the first set of primary symbols.

4. The plurality of playing cards according to claim 1 wherein the first side bears at least a second primary symbol, the second primary symbol selected from a second set of primary symbols, each of the second primary symbols in the second set of primary symbols indicative of the playing card identity in combination with the first primary symbols from the first set of primary symbols according to the first set of game rules, the first set of game rules defining values of various combinations of the playing card identities.

5. The plurality of playing cards according to claim 4 wherein the first set of primary symbols comprises a standard set of playing card rank symbols 2, 3, 4, 5, 6, 7, 8, 9, 10, J, Q, K, and A.

6. The plurality of playing cards according to claim 5 wherein the second set of primary symbols comprises a standard set of playing card suit symbols ♠, ♣, ♦, and ♠.

7. The plurality of playing cards according to claim 6 wherein the second side bears at least a second secondary symbol, the second secondary symbol selected from a second set of secondary symbols, each of the second secondary symbols in the second set of secondary symbols indicative of the playing card identity in combination with the first secondary symbols from the first set of secondary symbols according to the second set of game rules, the second set of game rules defining values of various combinations of the playing card identities.

8. The plurality of playing cards according to claim 7 wherein the first set of secondary symbols comprises a standard set of playing card rank symbols 2, 3, 4, 5, 6, 7, 8, 9, 10, J, Q, K, and A.

9. The plurality of playing cards according to claim 8 wherein the first set of secondary symbols comprises a standard set of playing card suit symbols ♠, ♣, ♦, and ♠.

10. The plurality of playing cards according to claim 9 wherein the first and second primary symbols on the first side of any of the playing cards where the second primary symbol on the first side is one of the ♠ and the ♦ are a first color and the first and the second primary symbols on the first side of any of the playing cards where the second primary symbol on the first side is one of the ♣ and the ♠ is a second color, and wherein the first and the second secondary symbols on the second side of any of the playing cards where the second secondary symbol on the second side is one of the ♠ and the ♦ are the first color and the first and the second secondary symbols on the second side of any of the playing cards where the second secondary symbol on the second side is one of the ♣ and the ♠ is the first color.

11. The plurality of playing cards according to claim 1 wherein the first set of game rules are game rules for one of Blackjack, Poker, Baccarat, Caribbean Stud Poker, and LET IT RIDE.

12. The plurality of playing cards according to claim 11 wherein the second set of game rules are game rules for one of Blackjack, Poker, Baccarat, Caribbean Stud Poker, and LET IT RIDE.

13. The plurality of playing cards according to claim 11 wherein the second set of game rules are identical to the first set of game rules.

14. The plurality of playing cards according to claim 11 wherein the second set of game rules are different than the first set of game rules.

15. The plurality of playing cards according to claim 1 wherein the first set of secondary symbols comprises at least a subset of standard slot machine symbols including a cherry, a bar, and a bell.

16. The plurality of playing cards according to claim 1 wherein the first set of secondary symbols comprises a set of numbers.

17. The plurality of playing cards according to claim 1 wherein the first set of secondary symbols comprises a set of graphics.

18. The plurality of playing cards according to claim 1 wherein the first set of secondary symbols comprises a set of graphics, at least some of the graphics in the set of graphics forming at least one rebus.

19. The plurality of playing cards according to claim 1 wherein the second set of game rules define values of various combinations of the playing card identities according to a number of playing cards collected having matching secondary symbols on the second side of the playing cards and a relative ordering of the matching secondary symbols with respect to the other secondary symbols comprising the first set of secondary symbols.

20. The plurality of playing cards according to claim 1 wherein the second set of game rules define values of various combinations of the playing card identities according to a number of playing cards collected having matching secondary symbols on the second side of the playing cards.

21. The plurality of playing cards according to claim 1 wherein the second set of game rules define values of various combinations of the playing card identities according to a cumulative value of a collection of playing cards determined by adding a value represented by the secondary symbols on the second side of the playing cards.

22. (canceled)

23. The plurality of playing cards according to claim 1 wherein a first probability of the first symbol appearing on the first side is dependent on a second probability of the first secondary symbol appearing on the second side.

24. The plurality of playing cards of claim 1 wherein two playing cards in the first plurality of playing cards have a same identity.

25. A set of playing cards for wagering, each of the playing cards comprising:

a first side bearing at least a first primary symbol and a second primary symbol, the first primary symbol selected from a standard set of playing card rank symbols comprising 2, 3, 4, 5, 6, 7, 8, 9, 10, J, Q, K, and A, and the second primary symbol selected from a standard set of playing card suit symbols ♠, ♣, ♦, and ♠, the combination of the first and the second primary symbols on each of the playing cards indicative of a first respective playing card identity; and

a second side bearing at least a first secondary symbol, the first secondary symbol on the second side selected from a first set of secondary symbols, each of the first secondary symbols in the first set of secondary symbols indicative of a respective second playing card identity according to a set of game rules the second playing card identity independent of the first playing card identity.

26. The set of playing cards according to claim 25 wherein the first set of secondary symbols comprises at least a subset of standard slot machine symbols including a cherry, a bar, and a bell.

27. The set of playing cards according to claim 25 wherein the first set of secondary symbols comprises a set of integers.

28. The set of playing cards according to claim 25 wherein the first set of secondary symbols comprises a set of graphics.

29. The set of playing cards according to claim 25 wherein the first set of secondary symbols comprises a set of graphics, at least some of the graphics in the set of graphics forming at least one rebus.

30. The set of playing cards according to claim 25 wherein the set of playing cards includes fifty-two playing cards, the first side of each of the playing cards bearing a respective combination of the first primary symbol and the second primary symbol, and wherein the first secondary symbol on the second side of the playing card is not discernible from the first primary symbol and the second primary symbol on the first side of the playing card.

31. A method of producing playing cards having a face and a back, the method comprising:

forming at least a first primary symbol on the face of the playing card, the first primary symbol from a first set of primary symbols and indicative of a first playing card identity of a playing card according to a first set of game rules, the first set of game rules defining values of various combinations of the first playing card identities;

pseudo-randomly generating at least a first secondary symbol from a first set of secondary symbols, each of the secondary symbols in the first set of secondary symbols indicative of a second playing card identity according to a second set of game rules, the second set of game rules defining values of the second playing card identities independent of the first playing card identities; and

forming the first secondary symbol on the back of the playing card.

32. The method according to claim 31, the method further comprising:

forming at least a second primary symbol on the face of the playing card, the second primary symbol from a second set of primary symbols where the first set of primary symbols is a standard set of playing card ranks and the second set of primary symbols is a standard set of playing card suits.

33. The method according to claim 32, further comprising:

pseudo-randomly generating the first and the second primary symbols.

34. The method according to claim 31 wherein forming the first secondary symbol on the back of the playing card comprises printing the first secondary symbol on a portion of the back of the playing card.

35-37. (canceled)

38. The method according to claim 31 wherein pseudo-randomly generating at least a first secondary symbol further comprises pseudo-randomly generating the first secondary symbol and a second secondary symbol, the second secondary symbol from a second set of secondary symbols, the combination of the first and the second secondary symbols indicative of the second playing card identity according to the second set of game rules where the first set of secondary symbols comprises a standard set of playing card ranks and the second set of secondary symbols comprises a standard set of playing card suits.

39. The plurality of playing cards according to claim 38 wherein if the second primary symbol on the playing card is one of the ♥ and the ♦ then forming the first and the second primary symbols comprises printing with a first color and if the second primary symbol on the playing card is one of the ♣ and the ♠ then forming the first and the second primary symbols comprises printing with a second color and if the second secondary symbol on the playing card is one of the ♥ and the ♦ then forming the first and the second secondary symbols comprises printing with the second color and if the second secondary symbol on the playing card is one of the ♣ and the ♠ then forming the first and the second secondary symbols comprises printing with the first color.

40. The method according to claim 31, further comprising:

removing the playing card from a printer after forming one of the first primary symbol and the first secondary symbol;

reinserting the playing card in the printer before forming the other one of the first primary symbol and the first secondary symbol.

41. The method according to claim 31 wherein both the first primary symbol and the first secondary symbol are formed before removing the playing card from a symbol forming device.

42. A device for producing playing cards, the device comprising:

a housing;

a media path extending through the housing along which playing card stock passes;

at least a one printhead coupled to receive print data, the at least one printhead proximate the media path and operable to print on the playing card stock passing the printhead along the media path; and

at least one processor configured to pseudo-randomly generate at least a number of first secondary identifiers, each of the first secondary identifiers corresponding to a respective first secondary symbol, the first secondary symbols being from a first set of secondary symbols, where the at least one processor is coupled to provide print data representing the first secondary symbols and representing at least a number of first primary symbols, the first primary symbols from a first set of primary symbols, the at least one processor configured to cause the printhead to print the first secondary symbol on a back of the playing card stock and to print the first primary symbol on a face of the playing card stock, where each of the primary symbols in the first set of primary symbols indicative of a playing card identity

according to a first set of game rules, the first set of game rules defining values of various combinations of the playing card identities and each of the secondary symbols in the first set of secondary symbols indicative of a playing card identity according to a second set of game rules.

43. The device according to claim 42 wherein the processor is further configured to pseudo-randomly generate at least a first number of first primary identifiers representing respective ones of the first primary symbols.

44. The device according to claim 42 wherein the processor is further configured to pseudo-randomly generate at least a first number of primary identifiers representing respective combinations of the first primary symbol and a second primary symbol, the second primary symbol from a second set of primary symbols.

45. The device according to claim 42, further comprising:

at least a second printhead opposed across the media path with respect to the first printhead to print on the opposite side of the playing card stock from the first printhead.

46. A method of producing playing cards having a face and a back, the face bearing a first primary symbol from a first set of primary symbols and a second primary symbol from a second set of primary symbols, the first and the second primary symbols pre-printed on the face of the playing card and indicative of an a first playing card identity of a playing card according to a first set of game rules, the first set of game rules defining values of various combinations of the first playing card identities, the method comprising:

pseudo-randomly generating at least a first secondary symbol from a first set of secondary symbols, each of the secondary symbols in the first set of secondary symbols indicative of a second playing card identity according to a second set of game rules, the second set of game rules defining values of the second playing card identities the second playing card identities independent of the first playing card identities; and

forming the first secondary symbol on the back of the playing card.

47. The method according to claim 46 wherein the first set of primary symbols is a standard set of playing card ranks and the second set of primary symbols is a standard set of playing card suits, and wherein pseudo-randomly generating at least a first secondary symbol from a first set of secondary symbols comprises pseudo-randomly generating the first secondary symbol from at least a subset of standard slot machine symbols.

48. (canceled)

49. A device for producing playing cards from preprinted playing card stock, the preprinted playing card stock bearing a first and a second symbol selected from a standard set of playing card rank symbols and a standard set of playing card suit symbols, respectively, the device comprising:

a housing;

a media path extending through the housing along which the playing card stock passes;

at least a one printhead coupled to receive print data, the at least one printhead proximate the media path and

operable to print on the playing card stock passing the printhead along the media path; and

at least one processor configured to pseudo-randomly generate at least a number of first secondary identifiers, each of the first secondary identifiers corresponding to a respective first secondary symbol, the first secondary symbols from a first set of secondary symbols, where the at least one processor is coupled to provide the print data representing the first secondary symbols to cause the printhead to print the first secondary symbols on a back of the playing card stock.

**50.** The device according to claim 49 wherein the at least one processor comprises a first processor configured to pseudo-randomly generate at least a first number of identifiers and a second processor configured to provide the print data representing the first secondary symbols.

**51.** A method of contemporaneously playing two card games with a dual-sided card deck, the method comprising:

dealing a number of playing cards to at least a first player, each playing card having at least a first primary symbol on a first side and at least a first secondary symbol on a second side, the first primary symbols from a first set of primary symbols and the first secondary symbols from a first set of secondary symbols;

determining an outcome of a first game according to a first set of game rules based at least in part on the first primary symbol on the first side of at least one of the number of playing cards; and

determining an outcome of a second game according to a second set of game rules based at least in part on the first secondary symbol on the second side of at least one of the number of playing cards.

**52.** The method according to claim 51 wherein the first set of game rules is one of blackjack rules and baccarat rules, the first set of primary symbols is a set of stand playing card rank symbols, and determining an outcome of a first game according to a first set of game rules based at least in part on the first primary symbol on the first side of at least one of the number of playing cards comprises:

determining a value for each of the playing cards corresponding to the rank symbol on the first side of the playing card;

summing each of the determined values for the number of playing cards; and

comparing the sum of the values to at least one other value.

**53.** The method according to claim 52 wherein the second set of game rules is one of blackjack rules and baccarat rules, the first set of secondary symbols is a set of stand playing card rank symbols, and determining an outcome of a second game according to a second set of game rules based at least in part on the first secondary symbol on the second side of at least one of the number of playing cards comprises:

determining a value for each of the playing cards corresponding to the rank symbol on the second side of the playing card;

summing each of the determined values for the number of playing cards; and

comparing the sum of the values to at least one other value.

**54.** The method according to claim 51 wherein the first set of game rules is poker, the first set of face symbols is a set of stand playing card rank symbols, and determining the outcome of the first game comprises:

determining a rank and suit for each of the playing cards corresponding to the first primary identifier and a second primary identifier, respectively;

determining a number of combinations of the playing cards having identical ranks and the number of playing cards in each determined combination;

determining a number of combinations of the playing cards having identical suits and the number of playing cards in each determined combination; and

comparing the determined number of combinations of playing cards having identical ranks and identical suits and the number of playing cards in each combination to at least one other hand of playing cards employing a set of predefined rankings.

**55.** The method according to claim 51 wherein determining an outcome of a second game according to a second set of game rules based at least in part on the first secondary symbol on the second side of at least one of the number of playing cards comprises determining an existence or absence of a particular one of the first secondary symbols on at least one of the playing cards.

**56.** The method according to claim 51 wherein determining an outcome of a second game according to a second set of game rules based at least in part on the first secondary symbol on the second side of at least one of the number of playing cards comprises determining a quantity of the playing cards having identical first secondary symbols.

**57.** The method according to claim 51 where the first set of secondary symbols comprises at least a cherry symbol, a bell symbol and a bar symbol, and wherein determining an outcome of a second game according to a second set of game rules based at least in part on the first secondary symbol on the second side of at least one of the number of playing cards comprises determining a quantity of the playing cards having identical first secondary symbols.

**58.** The method according to claim 51 where the first set of secondary symbols comprises a number of graphics, at least some of the graphics forming a rebus, and wherein determining an outcome of a second game according to a second set of game rules based at least in part on the first secondary symbol on the second side of at least one of the number of playing cards comprises determining whether the player correctly solves the rebus formed by the first secondary symbols on the playing cards.

**59.** The method according to claim 51 where the first set of secondary symbols comprises a number of graphics, at least some of the graphics representing at least one prize, and wherein determining an outcome of a second game according to a second set of game rules based at least in part on the first secondary symbol on the second side of at least one of the number of playing cards comprises determining whether the existence of at least one playing card in the number of playing cards bearing one of the first secondary symbols representing one of the prizes.

**60.** A method of playing a wagering game, the method comprising:

dealing a number of hands of playing cards to each of a number of players, each playing card having at least a first primary symbol on a first side and at least a first secondary symbol on a second side, the first primary symbols from a first set of primary symbols and the first secondary symbols from a first set of secondary symbols;

determining an outcome of a first game according to a first set of game rules based at least in part on the first primary symbol on the first side of at least one of the number of playing cards of each hand; and

for each of a number of winning hands determined based at least in part on the first primary symbol on the first side of at least one of the number of playing cards of each hand, determining an outcome of a second game according to a second set of game rules based at least in part on the first secondary symbol on the second side of at least one of the number of playing cards.

**61.** The method of claim 60 wherein determining an outcome of a first game according to a first set of game rules based at least in part on the first primary symbol on the first side of at least one of the number of playing cards of each hand comprises determining the outcome of the first game based on a value of the hand of playing cards based on a value of the first primary symbol on each of the playing card in the hand.

**62.** The method of claim 60 wherein determining an outcome of a second game according to a second set of game rules based at least in part on the first primary symbol on the second side of at least one of the number of playing cards comprises determining the outcome of the second game based on value of the hand of playing cards based on a value of the first primary symbol on each of the playing card in the hand.

**63.** The method of claim 60 wherein determining an outcome of a second game according to a second set of game rules based at least in part on the first secondary symbol on the second side of at least one of the number of playing cards comprises determining the outcome of the second game based a number of the playing cards in the hand that each have a same one of the first secondary symbols.

**64.** The method of claim 60, further comprising:

for each of a number of winning hands determined based at least in part on the first primary symbol on the first side of at least one of the number of playing cards of each hand; providing the player a first payout; and

for each of a number of winning hands determined based at least in part on the first secondary symbol on the second side of at least one of the number of playing cards of each hand, providing the player a second payout.

**65.** The method of claim 60, further comprising:

for each of a number of winning hands determined based at least in part on the first secondary symbol on the second side of at least one of the number of playing cards of each hand, enhancing a payout to the player.

**66.** A method of playing a wagering game, the method comprising:

dealing a number of hands of playing cards to each of a number of players, each playing card having at least a first primary symbol on a first side and at least a first

secondary symbol on a second side, the first primary symbols from a first set of primary symbols and the first secondary symbols from a first set of secondary symbols;

determining an outcome of a first game according to a first set of game rules based at least in part on the first primary symbol on the first side of at least one of the number of playing cards of each hand; and

for each of a number of losing hands, determining an outcome of a second game according to a second set of game rules based at least in part on the first secondary symbol on the second side of at least one of the number of playing cards.

**67.** The method of claim 66 wherein determining an outcome of a first game according to a first set of game rules based at least in part on the first primary symbol on the first side of at least one of the number of playing cards of each hand comprises determining the outcome of the first game based on value of the hand of playing cards based on a value of the first primary symbol on each of the playing card in the hand.

**68.** The method of claim 66 wherein determining an outcome of a second game according to a second set of game rules based at least in part on the first secondary symbol on the second side of at least one of the number of playing cards comprises determining the outcome of the second game based on value of the hand of playing cards based on a value of the first secondary symbol on each of the playing card in the hand.

**69.** The method of claim 66 wherein determining an outcome of a second game according to a second set of game rules based at least in part on the first secondary symbol on the second side of at least one of the number of playing cards comprises determining the outcome of the second game based a number of the playing cards in the hand that each have a same one of the first secondary symbols.

**70.** The method of claim 66 wherein determining an outcome of a second game according to a second set of game rules based at least in part on the first secondary symbol on the second side of at least one of the number of playing cards comprises determining the outcome of the second game based at least one of the playing cards in the hand having a particular one of the first secondary symbols.

**71.** A method of playing a card game, the method comprising:

for each of a number of players, determining if the player placed a primary wager;

dealing a number of hands of playing cards to each of a number of players who placed a respective one of the primary wagers, each playing card having at least a first primary symbol on a first side and at least a first secondary symbol on a second side, the first primary symbols from a first set of primary symbols and the first secondary symbols from a first set of secondary symbols;

determining an outcome of a first game according to a first set of game rules based at least in part on the first primary symbol on the first side of at least one of the number of playing cards of each hand;

determining an outcome of a second game according to a second set of game rules based at least in part on the



first secondary symbol on the second side of at least one of the number of playing cards; and

for each of a number of winning hands, if any, determined based at least in part on the first secondary symbol on the second side of at least one of the number of playing cards of each hand, providing the player an award.

72. The method according to claim 71, further comprising:

determining an amount of the award according to a predetermined payout schedule.

73. The method according to claim 71, further comprising:

determining an amount of the award based at least on a value assigned to at least the first secondary symbol.

74. The method according to claim 71, further comprising:

determining an amount of the award based at least one of a good and a service represented by at least the first secondary symbol.

75. A method of playing a card game, the method comprising:

for each of a first number of players, determining if the player placed a primary wager;

dealing a number of hands of playing cards to each of the players who placed a respective one of the primary wagers, each playing card having at least a first primary symbol on a first side and at least a first secondary symbol on a second side, the first primary symbols from a first set of primary symbols and the first secondary symbols from a first set of secondary symbols;

determining an outcome of a first game according to a first set of game rules based at least in part on the first primary symbol on the first side of at least one of the number of playing cards of each hand;

for each of a second number of players, determining if the player placed a secondary wager; and

for each of the players who placed a secondary wager, determining an outcome of a second game according to a second set of game rules based at least in part on the first secondary symbol on the second side of at least one of the number of playing cards in the respective hand of playing cards.

76. The method of claim 75, further comprising:

for each of a number of winning hands determined based at least in part on the first primary symbol on the first side of at least one of the number of playing cards of each hand; providing the player a first payout; and

for each of a number of winning hands determined based at least in part on the first secondary symbol on the second side of at least one of the number of playing cards of each hand, providing the player a second payout.

77. The method of claim 75, further comprising:

for each of a number of winning hands determined based at least in part on the first secondary symbol on the second side of at least one of the number of playing cards of each hand, enhancing a base payout to the player.

78. The method of claim 75 wherein the second number of players is equal to the first number of players.

79. A device for producing playing cards, the device comprising:

means for pseudo-randomly generating at least a number of first secondary identifiers;

means for associating the number of first secondary identifiers with respective ones of a number of first secondary symbol, the first secondary symbols from a first set of secondary symbols, each of the secondary symbols in the first set of secondary symbols indicative of a playing card identity according to one set of game rules; and

means for printing the first secondary symbols on a back of a playing card stock where a face of the playing card stock bears a first and a second primary symbols, the first and the second primary symbols from a standard set of playing card ranks and a standard set of playing card suits, respectively.

80. The device according to claim 79, further comprising:

means for pseudo-randomly generating at least a number of first primary identifiers;

means for associating the number of first primary identifiers with respective ones of the number of first primary symbols; and

means for printing the first primary symbols on the face of the playing card stock.

81. The device according to claim 80 wherein the means for pseudo-randomly generating at least a number of first secondary identifiers is independent of the first primary identifiers.

82. The device according to claim 80 wherein the means for pseudo-randomly generating at least a number of first secondary identifiers is dependent of the first primary identifiers.

\* \* \* \* \*