

(19) World Intellectual Property  
Organization  
International Bureau



(43) International Publication Date  
10 September 2004 (10.09.2004)

PCT

(10) International Publication Number  
**WO 2004/075951 A2**

- (51) International Patent Classification<sup>7</sup>: **A61M**
- (21) International Application Number:  
PCT/US2004/005623
- (22) International Filing Date: 25 February 2004 (25.02.2004)
- (25) Filing Language: English
- (26) Publication Language: English
- (30) Priority Data:  
60/449,883 25 February 2003 (25.02.2003) US
- (71) Applicant (for all designated States except US): **THE CLEVELAND CLINIC FOUNDATION** [US/US]; 9500 Euclid Avenue, Cleveland, OH 44195 (US).
- (72) Inventors: **NAVIA, Jose, L.**; 2702 Cranlyn Road, Shaker Heights, OH 44122 (US). **NAVIA, Jose, Antonio**; 1308 Suipacha, Apt. 4B, Buenos Aires (AR). **JORDANA, Jorge, Luis**; 4980 Avenida Libertador, Apt. 5B, 1426 Buenos Aires (AR).
- (74) Agent: **WESORICK, Richard, S.**; Tarolli, Sundheim, Covell & Tummino L.L.P., Suite 1111, 526 Superior Avenue, Cleveland, OH 44195 (US).
- (81) Designated States (unless otherwise indicated, for every kind of national protection available): AE, AG, AL, AM, AT, AU, AZ, BA, BB, BG, BR, BW, BY, BZ, CA, CH, CN, CO, CR, CU, CZ, DE, DK, DM, DZ, EC, EE, EG, ES, FI, GB, GD, GE, GH, GM, HR, HU, ID, IL, IN, IS, JP, KE, KG, KP, KR, KZ, LC, LK, LR, LS, LT, LU, LV, MA, MD, MG, MK, MN, MW, MX, MZ, NA, NI, NO, NZ, OM, PG, PH, PL, PT, RO, RU, SC, SD, SE, SG, SK, SL, SY, TJ, TM, TN, TR, TT, TZ, UA, UG, US, UZ, VC, VN, YU, ZA, ZM, ZW.
- (84) Designated States (unless otherwise indicated, for every kind of regional protection available): ARIPO (BW, GH, GM, KE, LS, MW, MZ, SD, SL, SZ, TZ, UG, ZM, ZW), Eurasian (AM, AZ, BY, KG, KZ, MD, RU, TJ, TM), European (AT, BE, BG, CH, CY, CZ, DE, DK, EE, ES, FI, FR, GB, GR, HU, IE, IT, LU, MC, NL, PT, RO, SE, SI, SK, TR), OAPI (BF, BJ, CF, CG, CI, CM, GA, GN, GQ, GW, ML, MR, NE, SN, TD, TG).
- Published:**  
— without international search report and to be republished upon receipt of that report
- For two-letter codes and other abbreviations, refer to the "Guidance Notes on Codes and Abbreviations" appearing at the beginning of each regular issue of the PCT Gazette.

(54) Title: APPARATUS AND METHOD FOR AUTO-RETROPERFUSION OF A CORONARY VEIN

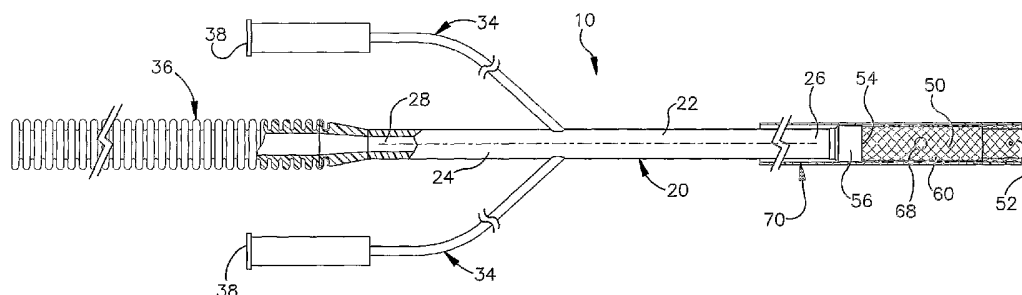

(57) Abstract: An apparatus for automatically retroperfusing a coronary vein includes an intraluminal cannula having a main body portion extending between a proximal end portion and a distal end portion. The proximal end portion is for connecting to an artery outside of the pericardium to automatically supply oxygenated blood from the artery for retroperfusion. The main body portion and the distal end portion are insertable through a vein that is fluidly connected with the coronary vein and into the coronary vein. An expandable stent is attached to the distal end portion for expanding radially into engagement with the interior wall of the coronary vein to secure the distal end portion at a desired location within the coronary vein. Occluding structure for at least partially occluding the coronary vein is provided at the distal end to decrease the back-flow of blood into the right atrium during retroperfusion.

WO 2004/075951 A2

**APPARATUS AND METHOD FOR  
AUTO-RETROPERFUSION OF A CORONARY VEIN**

**Related Application**

This application claims priority from U.S. provisional patent  
5 application Serial No. 60/449,883, filed on February 25, 2003, the subject  
matter of which is incorporated herein by reference.

**Technical Field**

The present invention relates to an apparatus and method for  
automatically retroperfusing a coronary vein with oxygenated blood from an  
10 artery.

**Background of the Invention**

In the United States alone, over 1.5 million persons annually suffer  
from intractable ischemia or acute myocardial infarction, or both. It is  
known to use retroperfusion techniques to treat such conditions.  
15 Retroperfusion techniques for the heart generally involve the delivery of  
arterial oxygenated or venous blood. This blood is delivered retrogradely  
to the endangered ischemic myocardium through its adjoining coronary

-2-

veins in a direction opposite to the normal outflow of venous blood through that vein. The retroperfused blood crosses from the coronary veins into the tissue capillary circulation, e.g., as microcirculation, to provide blood and nourishment to an underperfused myocardium.

5           Coronary sinus retroperfusion limits or reduces myocardial damage when administered as a preemptive or remedial treatment, or both.

Coronary sinus retroperfusion may also be effective therapy when targeted to slow or, in some cases, reverse the progression from myocardial ischemia to the irreversible damage associated with myocardial infarction.

10          Further, coronary sinus retroperfusion may provide a temporary therapeutic window to achieve even more complete revascularization, such as by Percutaneous Transluminal Coronary Angioplasty (PTCA) or Coronary Artery By-Pass Grafting (CABG), and may also permit physicians to improve myocardial salvage.

15           Typically, a two-step surgical procedure is utilized that involves creating an interventional shunt from an artery to the coronary sinus (venous circulation), and subsequently restricting the flow of blood through the coronary sinus, such as with an occluding balloon, to facilitate effective retroperfusion of coronary veins with arterial blood provided via an  
20          intraluminal catheter. The occlusion of the coronary sinus helps to prevent excessive back-flow of blood into the right atrium.

The balloon used to occlude the coronary sinus is often also used to retain the intraluminal catheter in place inside the patient. The balloon is inflated inside the ostium downstream of the middle cardiac vein (serving

the right ventricular territory), in the space between the middle cardiac vein and the veins coming from the left ventricle. The infusion thus occurs distal to the balloon. Because the space upstream of the middle cardiac vein between the ostium and the middle cardiac vein is too small to contain the  
5 balloon, the middle cardiac vein must be excluded from the perfusion. Consequently, the right ventricle is left unprotected during heart surgery. Therefore, although vessel occlusion may be required in a retroperfusion procedure, use of the inflated balloon to occlude the vessel can be disadvantageous.

10 Attempts have been made to improve the catheter design to minimize the obstruction of the branch lumens. These catheter designs included shortening the retention balloon. Although the use of protuberances or ridges on the balloon surface to improve the frictional contact has been suggested, the shortened balloon may provide insufficient  
15 frictional contact with the lumen surface. Fixation balloons made of an open-walled element material, which permits blood to flow freely through the open-walled element material, are also known.

### **Summary of the Invention**

20 The present invention provides an apparatus for automatically retroperfusing a coronary vein with oxygenated blood from an artery. The apparatus comprises an intraluminal cannula having a main body portion extending between a proximal end portion and a distal end portion. The proximal end portion is for connecting to an artery outside of the pericardium to automatically supply oxygenated blood from the artery for

-4-

retroperfusion of the coronary vein. The main body portion and the distal end portion are insertable through a vein that is fluidly connected with the coronary vein to be retroperfused and into the coronary vein. An expandable stent is attached to the distal end portion of the cannula for expanding radially into engagement with the interior wall of the coronary vein to secure the distal end portion at a location within the coronary vein. Occluding means for at least partially occluding the coronary vein is provided to decrease the back-flow of blood into the right atrium during retroperfusion. The occluding means is located at the distal end portion of the cannula.

In accordance with one aspect of the invention, the apparatus occluding means is disposed within the stent.

In accordance with another aspect of the invention, the occluding means comprises an umbrella-shaped membrane defined by an open end and a closed end. The closed end is attached to an outer surface of the distal end portion of the cannula. The open end is attached to the stent so that, when the stent is expanded, the membrane spans a radial distance between the interior wall of the coronary vein and the outer surface of the distal end portion of the cannula.

In accordance with another aspect of the invention, the membrane includes at least one opening to allow limited blood flow across the membrane.

In accordance with another aspect of the invention, the occluding means comprises an inflatable balloon, the balloon having a plurality of

lobes disposed circumferentially about the distal end portion of the cannula, the plurality of lobes defining a plurality of radial gaps between the lobes through which a limited quantity of blood may flow.

In accordance with another aspect of the invention, the proximal end  
5 portion of the cannula comprises a graft for suturing to the artery outside of the pericardium to automatically supply oxygenated blood for retroperfusion of the coronary vein.

In accordance with another aspect of the invention, the graft is positioned subcutaneously following suturing to the artery.

10 In accordance with another aspect of the invention, the apparatus further comprises a catheter for inserting into the artery to access the oxygenated blood and a connecting tube that is attached between the catheter and the proximal end portion of the cannula.

In accordance with another aspect of the invention, the catheter and  
15 the proximal end portion of the cannula extend percutaneously and the connecting tube lies above the skin.

In accordance with another aspect of the invention, the intraluminal cannula includes a plurality of lumens.

In accordance with another aspect of the invention, the distal end  
20 portion of the cannula includes a plurality of openings, each of the plurality of openings being fluidly connected with a respective one of the plurality of lumens in the cannula.

-6-

In accordance with another aspect of the invention, the apparatus further includes a removable sheath for enclosing the intraluminal cannula during insertion of the distal end portion into the coronary vein.

In accordance with another aspect, the present invention provides  
5 an apparatus for automatically retroperfusing a coronary vein with  
oxygenated blood from an artery. The apparatus comprises an intraluminal  
cannula having a main body portion extending between a proximal end  
portion and a distal end portion. The proximal end portion is for connecting  
to an artery to automatically supply oxygenated blood from the artery for  
10 retroperfusion of the coronary vein. The main body portion and the distal  
end portion are insertable through a vein that is fluidly connected with the  
coronary vein to be retroperfused and into the coronary vein. An  
expandable stent is attached to the distal end portion of the cannula for  
expanding radially into engagement with the interior wall of the coronary  
15 vein to secure the distal end portion at a location within the coronary vein.  
Occluding means for at least partially occluding the coronary vein is  
provided to decrease the back-flow of blood into the right atrium during  
retroperfusion. The occluding means is disposed within the stent.

In accordance with another aspect of the invention, a method for  
20 automatically retroperfusing a coronary vein with oxygenated blood from an  
artery is provided. According to the inventive method, an intraluminal  
cannula is provided. The cannula has a main body portion extending  
between a proximal end portion and a distal end portion. The distal end  
portion includes an expandable stent and occluding means for at least

-7-

partially occluding the coronary vein. The main body portion and the distal end portion of the cannula are inserted through a vein that is fluidly connected with the coronary vein to be retroperfused and into the coronary vein. The stent is radially expanded into engagement with the interior wall of the coronary vein to secure the distal end portion at a location within the coronary vein, wherein the radial expansion of the stent causes the occluding means to span the coronary vein. The proximal end portion of the cannula is fluidly connected to an artery to automatically supply oxygenated blood for retroperfusion, wherein the occluding means at least partially occludes the coronary vein to decrease the back-flow of blood into the right atrium during retroperfusion.

#### **Brief Description of the Drawings**

The foregoing and other features of the present invention will become apparent to those skilled in the art to which the present invention relates upon reading the following description with reference to the accompanying drawings, in which:

Fig. 1 is a side view, partly in section, of an apparatus for automatically retroperfusing a coronary vein in accordance with a first embodiment of the present invention, the apparatus being shown in a first condition;

Fig. 2 is a view similar to Fig. 1 illustrating the apparatus in a second condition;

Fig. 2A is an enlarged view of an end portion of the apparatus shown in Fig. 2;



-8-

Fig. 3 is a section view taken along line 3-3 in Fig. 2A;

Fig. 4 is a section view taken along 4-4 in Fig. 3;

Fig. 5 is a front view of a patient and includes an enlarged area illustrating the location where the apparatus is inserted into the patient;

5 Fig. 6 is a schematic view of the apparatus being passed through a vein and the right atrium to a location in a coronary vein to be retroperfused;

Fig. 7 is an enlarged view of a portion of Fig. 6 illustrating an end portion of the apparatus in the coronary vein;

10 Fig. 8 is a schematic view of the apparatus of Fig. 1 being passed through a different vein to the location in a coronary vein to be retroperfused and also illustrates a different artery for providing the oxygenated blood;

Fig. 9 is a side view, partly in section, of an apparatus for  
15 automatically retroperfusing a coronary vein in accordance with a second embodiment of the present invention, the apparatus being shown in a first condition;

Fig. 10 is a section view of an end portion of the apparatus of Fig. 9 illustrating the apparatus in a second condition;

20 Fig. 11 is a section view taken along line 11-11 in Fig. 10;

Fig. 12 is a schematic view of the apparatus of Fig. 9 illustrating the end portion in the coronary vein;

Fig. 13 is a schematic view of an apparatus for automatically retroperfusing a coronary vein in accordance with a third embodiment of

the present invention, the apparatus being shown in an installed condition;  
and

Fig. 14 is a schematic view of the apparatus of Fig. 13 being passed  
through a different vein to the location in a coronary vein to be  
5 retroperfused and also illustrates a different artery for providing the  
oxygenated blood.

### **Description of Embodiments**

The present invention relates to an apparatus and method for  
automatically retroperfusing a coronary vein with oxygenated blood from an  
10 artery to treat severely symptomatic patients requiring an increase of  
oxygen supply to an ischemic myocardium. As representative of the  
present invention, Fig. 1 illustrates an apparatus 10 for automatically  
retroperfusing a coronary vein in accordance with a first embodiment.

The apparatus 10 includes an intraluminal cannula 20. The  
15 cannula 20 has a main body portion 22 that extends between a proximal  
end portion 24 and a distal end portion 26. The main body portion 22 is  
constructed from a biocompatible, non-thrombogenic material including but  
not limited to PTFE, silicon rubber, or polyurethane. The main body  
portion 22 could alternatively be made from a biological material.

20 As best seen in Figs. 3 and 4, the main body portion 22 of the  
cannula 20 has a centrally located primary lumen 28 and a pair of  
oppositely disposed secondary lumens 30. It should be understood,  
however, that the cannula 20 could have more than the three lumens 28  
and 30, and could have a variety of different configurations for the lumens

-10-

in the cannula. The primary lumen 28 is larger in diameter than the secondary lumens 30 and is the passage through which oxygenated blood will flow. Accordingly, it is contemplated that the blood-contacting interior surface 32 of the primary lumen 28 may be exposed material or may act as a matrix for cell in-growth from host or seeded culture cells.

The proximal end portion 24 of the cannula 20 includes a pair of proximal extensions 34 (Fig. 1) that branch from the cannula and a graft section 36 for suturing to an artery outside of the pericardium to automatically supply oxygenated blood from the artery for retroperfusion of the coronary vein. The graft section 36 is a flexible tubular member that is fluidly connected to the primary lumen in the cannula. The graft section 36 is constructed from a suitable suturable material including but not limited to expanded PTFE, polyurethane, or a synthetic fabric such as Dacron®. The graft section 36 could alternatively be made from a biological tissue.

Each of the proximal extensions 34 at the proximal end portion 24 of the cannula 20 is fluidly connected, in a manner not shown, to a respective one of the secondary lumens 30 in the main body portion 22 of the cannula. Further, each of the proximal extensions 34 includes an end section that functions as a subcutaneous access port 38.

At the distal end portion 26 of the cannula 20, the primary lumen 28 terminates in an axial opening 40 at the terminal end of the cannula as shown in Fig. 3. Each of the two secondary lumens 30 terminates in a radial aperture 42 that is located adjacent the terminal end.

-11-

A radially expandable stent 50 is attached to the distal end portion 26 of the cannula 20. The stent 50 may be made of a variety of expandable materials including but not limited to polymeric materials, stainless steel, a NiTi alloy, a pseudoelastic NiTi alloy having a phase transition temperature above body temperature, cobalt, nickel, molybdenum, and a chromium alloy such as MP35N.

The stent 50 is disposed circumferentially about the distal end portion 26 of the cannula 20 and has oppositely disposed first and second ends 52 and 54. The first end 52 of the stent 50 is positioned nearest the terminal end of the cannula 20. The first end 52 is not attached to the cannula 20 and is radially expandable from a collapsed condition shown in Fig. 1 to an expanded condition shown in Fig. 2. The second end 54 of the stent 50 is secured to the outside of the distal end portion 26 of the cannula 20. The second end 54 may be secured to the cannula 20 by a collar 56 or any other suitable means.

The apparatus 10 further includes a membrane 60 for at least partially occluding the coronary vein to decrease the back-flow of blood into the right atrium during retroperfusion. The membrane 60 is located at the distal end portion 26 of the cannula 20 within the stent 50. The membrane 60 may be made from a biocompatible, non-thrombogenic synthetic material or a biological material. The surfaces of the membrane 60 may also be seeded with host or cultured cells to act as a matrix for cell in-growth.

-12-

The membrane 60 has an umbrella shape defined by an open end 62 and a closed end 64. The closed end 64 is attached to the outer surface of the distal end portion 26 of the cannula 20. The collar 56 used to secure the second end 54 of the stent 50 to the cannula 20 may also  
5 serve to secure the closed end 64 of the membrane 60 to the cannula. The open end 62 of the membrane 60 is attached to the stent 50 by sutures 66 (Fig. 3) or another suitable means so that, when the stent is expanded, the membrane spans the radial distance between the interior of the stent and the outer surface of the cannula 20 as shown in Fig. 2 and 3. The  
10 membrane 60 includes one or more openings 68 to allow limited blood flow through the membrane in order to decrease the back-flow of blood into the right atrium during retroperfusion.

The apparatus 10 further includes a removable sheath 70 (Fig. 1) that encloses the main body portion 22 and the distal end portion 26 of the  
15 cannula 20 and constrains the stent 50 in the collapsed condition of Fig. 1. As may be seen in Figs. 2, 2A, and 3, when the sheath 70 is pulled toward the proximal end portion 24 of the cannula 20 in the direction of arrow A in Fig. 2, the stent 50 and the open end 62 of the membrane 60 attached thereto expand to their respective expanded conditions. The sheath 70  
20 may also include a predetermined axial tear line (not shown) to permit the sheath to be peeled off the cannula 20 as the sheath is pulled proximally.

To perform automatic retroperfusion using the apparatus 10 in accordance with one embodiment of the present invention, the axillary vein 80 and the axillary artery 82 are exposed as shown in Fig. 5. The

-13-

distal end portion 26 of the cannula 20 is then introduced into the axillary vein 80 using the known Seldinger technique, which includes passing the cannula over a guidewire 84, under direct vision. During this step, the primary lumen 28 of the cannula 20 is used by the guidewire 84. The distal end portion 26 of the cannula 20 is then directed, via fluoroscopy, direct vision, transesophageal echocardiogram, or other suitable means, through the vasculature (i.e., the subclavian vein and the superior vena cava) and into the right atrium of the heart. The distal end portion 26 of the cannula 20 is further advanced through the right atrium and into the coronary sinus 86, which is the coronary vein to be retroperfused.

When the distal end portion 26 of the cannula 20 reaches the desired location in the coronary sinus 86, the sheath 70 is pulled proximally to release the stent 50 for expansion. The stent 50 then expands radially into engagement with the walls of the coronary sinus 86 to secure the distal end portion 26 of the cannula 20 in the coronary sinus 86 as shown in Figs. 6 and 7. As the stent 50 expands into engagement with the interior wall of the coronary sinus 86, the open end 62 of the membrane 60 is stretched across the coronary sinus 86 and spans the radial distance between the interior wall of the coronary sinus and the outer surface of the cannula 20. As may be seen in Fig. 7, with the distal end portion 26 of the cannula 20 secured in the coronary sinus 86 by the stent 50, the guidewire 84 is then removed. The sheath 70 is also removed from the cannula 20.

-14-

Next, an anastomosis of the proximal end portion 24 of the cannula 26 and the axillary artery 82 is accomplished by suturing the graft section 36 to the axillary artery as shown in Fig. 6. Normal antegrade blood flow continues as usual, but oxygenated blood is now automatically retroperfused through the cannula 20 to the ischemic myocardium via the coronary sinus 86. The oxygenated blood flow through the cannula 20 occurs throughout the cardiac cycle with a pulsatile flow pattern, but with a peak flow and pressure at the end of systole and the beginning of diastole. Excessive back-flow of blood into the right atrium from the coronary sinus 86 is prevented by the membrane 60.

It should be noted that the aforementioned procedure can be done under local anesthesia. Depending on the patient's particular condition, auto-retroperfusion can last for minutes, hours, days, or months. During retroperfusion, the secondary lumens 30 can be used for coronary sinus pressure measurement and the delivery of drugs, cells, genes, or growth factors. In accordance with the first embodiment of Figs. 1-7, it is expected that the access ports 38, which are fluidly connected with the secondary lumens 30, and the graft section 36 will be subcutaneous.

Fig. 8 illustrates use of the apparatus 10 to automatically retroperfuse the coronary sinus 86 through an anastomosis between the femoral vein 90 and the femoral artery 92. The distal end portion 26 of the cannula 20 is passed through the femoral vein 90, the iliac vein 94, and the inferior vena cava 96 to the right atrium of the heart. The distal end portion 26 of the cannula 20 is then advanced into the coronary sinus 86

-15-

and secured by the stent 50 in the same manner as discussed above. Finally, the graft section 36 at the proximal end 26 of the cannula 20 is sutured to the femoral artery 92 to provide oxygenated blood for retroperfusion of the coronary sinus 86. As with the previous embodiment, the entire apparatus 10, including the graft section 36 and the ports 38, remain subcutaneous following the anastomosis.

Figs. 9-12 illustrate an apparatus 110 for automatically retroperfusing a coronary vein in accordance with a second embodiment of the present invention. In the second embodiment of Figs. 9-12, reference numbers that are the same as those used in the first embodiment of Figs. 1-7 designate parts that are the same as parts in the first embodiment. The apparatus 110 according to the second embodiment is similar to the apparatus 10 of the first embodiment, but does not include the membrane 60. Rather, according to the second embodiment of the present invention, the means for at least partially occluding the coronary sinus 86 is an inflatable balloon 120.

The balloon 120 is attached to the distal end portion 26 of the cannula 20 within the stent 50. The balloon 120 is inflatable from a collapsed condition shown in Fig. 9 to an inflated condition shown in Figs. 10-12. The balloon 120 may be made from a biocompatible, non-thrombogenic synthetic material or a biological material. The outer surfaces of the balloon 120 may be seeded with host or cultured cells to act as a matrix for cell in-growth.



-16-

The balloon 120 has oppositely disposed first and second axial ends 122 and 124 (Fig. 10) and a plurality of lobes 126 that extend circumferentially about the distal end portion 26 of the cannula 20 between the first and second ends of the balloon. The lobes 126 define a plurality of radial gaps 128 between the lobes that allow a limited amount of blood flow past the balloon 120. As may be seen in Fig. 11, a plurality of tertiary lumens 130 may be present in the cannula 20 and fluidly connected with the lobes 126 of the balloon 120 so that the lobes can be inflated via one or more additional subcutaneous (or percutaneous) access ports (not shown). It is contemplated that the lobes 126 could also be self-inflated by blood during systole, which would advantageously allow the flow restriction to increase or decrease with a corresponding increase or decrease in coronary sinus pressure.

Automatic retroperfusion using the apparatus 110 according to the second embodiment of Figs. 9-12 is nearly identical to the method discussed above with regard to the first embodiment of Figs. 1-7, with the exception that the lobes 126 of the balloon 120 are inflated to at least partially occlude the coronary sinus 86 rather than the membrane 60 performing this function. As with the first embodiment, after the anastomosis of the graft section 36 at the proximal end portion 24 of the cannula 20 and the axillary artery 82 is completed, oxygenated blood is automatically retroperfused through the cannula to the ischemic myocardium via the coronary sinus 86. The oxygenated blood flow through the cannula 20 occurs throughout the cardiac cycle with a peak flow and

-17-

pressure at the end of systole and the beginning of diastole, and with excessive back-flow of blood into the right atrium from the coronary sinus 86 being prevented by the balloon 120.

5 Fig. 13 illustrates an apparatus 210 for automatically retroperfusing a coronary vein in accordance with a third embodiment of the present invention. In the third embodiment of Fig. 13, reference numbers that are the same as those used in the first embodiment of Figs. 1-7 designate parts that are the same as parts in the first embodiment.

10 The apparatus 210 according to the third embodiment is similar to the apparatus 10 of the first embodiment, but without the graft section 36 at the proximal end portion 24 of the cannula 20. Instead, the apparatus 210 includes a separate percutaneous catheter 220 for accessing the axillary artery 82 and a connecting tube 230 for fluidly coupling the catheter with the proximal end portion 24 of the cannula 20. As may be seen in Fig. 13,  
15 a proximal end 222 of the catheter 220, the proximal end portion 24 of the cannula 20 including the access ports 38, and the connecting tube 230 all lie above the skin 240 during the retroperfusion process.

Automatic retroperfusion using the apparatus 210 according to the third embodiment of Fig. 13 is nearly identical to the method discussed  
20 above with regard to the first embodiment of Figs. 1-7, with the exception that, following insertion of the cannula 20 into the axillary vein 80 and subsequent advancement into the coronary sinus 86, the catheter 220 is inserted into the axillary artery 82. The connecting tube 230 is then attached between the proximal end portion 24 of the cannula 20 and the

-18-

catheter 220 to supply oxygenated blood for automatic retroperfusion through the cannula to the ischemic myocardium via the coronary sinus 86. It should be noted that either the membrane 60 shown in Fig. 13 or the previously described balloon 120 can be used to prevent excessive back-  
5 flow of blood into the right atrium from the coronary sinus 86.

Fig. 14 illustrates use of the apparatus 310 to automatically retroperfuse the coronary sinus 86 via a fluid connection between the femoral vein 90 and the femoral artery 92. Following insertion of the cannula 20 into the femoral vein 90 and subsequent advancement into the  
10 coronary sinus 86, the catheter 220 is inserted into the femoral artery 92 and the connecting tube 230 is attached between the catheter and the proximal end portion 24 of the cannula 20. As may be seen in Fig. 14, the proximal end 222 of the catheter 220, the proximal end portion 24 of the cannula 20 including the access ports 38, and the connecting tube 230 all  
15 lie above the skin during the retroperfusion process.

As mentioned previously, the apparatus of the present invention are aimed at treating severely symptomatic patients requiring an increase of oxygen supply to the ischemic myocardium. The indications known at the present time for implantation of the apparatus disclosed herein can be  
20 transient or definitive according to a patient's evolution as follows:

1. Stunned left ventricle (LV) or hibernating  
LV: EF < 25%, with or without angina, with or without  
CHF symptoms with areas of myocardial viability;

-19-

2. AMI (with large ischemic area at risk with CHF symptoms) patients with more than 8 to 12 hs of evolution, with contraindications for fibrinolytic therapy and impossibility to perform rescue PTCA;
- 5 3. AMI with failed rescue PTCA, "No reflow phenomenon" (20-30% rescue AMI PTCA);
4. AMI – cardiogenic shock;
5. CHF FC III-IV with severe LV dysfunction (ischemic cardiomyopathy in heart transplant waiting list) or no  
10 option for heart transplant;
6. Severe stable or unstable angina in patients with severe diffuse coronary artery disease ("no option" patients for CABG or PTCA, 20 to 30% of the total coronary patients);
- 15 7. Redo coronary artery operation in patients, or "no option" patients indicated for CABG or PTCA;
8. Heart transplanted patients with progressive coronary artery disease;
9. High risk patients with concomitant diseases (COPD,  
20 chronic renal failure, neurological sequelae due to previous CVA with angina FC IV);
10. Drug delivery system: cardiotonics drugs, fibrinolytics, scavengers, blocking apoptosis, angiogenesis, myocytes, etc.;

-20-

11. Improve or accelerate the Bridge to Recovery in LVAD patients; and
12. Chronic support as a destination therapy.

5 From the above description of the invention, those skilled in the art will perceive improvements, changes and modifications. For example, it is contemplated that the apparatus could be used in other suitable veins and/or arteries besides the axillary and femoral locations described above. Such improvements, changes and modifications within the skill of the art are intended to be covered by the appended claims.

-21-

Having described the invention, we claim:

1. An apparatus for automatically retroperfusing a coronary vein with oxygenated blood from an artery, said apparatus comprising:

an intraluminal cannula having a main body portion extending between a proximal end portion and a distal end portion;

said proximal end portion for connecting to an artery outside of the pericardium to automatically supply oxygenated blood from the artery for retroperfusion of the coronary vein;

said main body portion and said distal end portion being insertable through a vein that is fluidly connected with the coronary vein to be retroperfused and into the coronary vein;

an expandable stent attached to said distal end portion of said cannula for expanding radially into engagement with the interior wall of the coronary vein to secure the distal end portion at a location within the coronary vein; and

occluding means for at least partially occluding the coronary vein to decrease the back-flow of blood into the right atrium during retroperfusion, said occluding means being located at said distal end portion of said cannula.

2. The apparatus of claim 1 wherein said occluding means is disposed within said stent.

-22-

3. The apparatus of claim 1 wherein said occluding means comprises an umbrella-shaped membrane defined by an open end and a closed end, said closed end being attached to an outer surface of said distal end portion of said cannula, said open end being attached to said stent so that, when said stent is expanded, said membrane spans a radial distance between the interior wall of the coronary vein and said outer surface of said distal end portion of said cannula.

4. The apparatus of claim 3 wherein said membrane includes at least one opening to allow limited blood flow across said membrane.

5. The apparatus of claim 1 wherein said occluding means comprises an inflatable balloon, said balloon having a plurality of lobes disposed circumferentially about said distal end portion of said cannula, said plurality of lobes defining a plurality of radial gaps between said lobes through which a limited quantity of blood may flow.

6. The apparatus of claim 1 wherein said proximal end portion of said cannula comprises a graft for suturing to the artery outside of the pericardium to automatically supply oxygenated blood for retroperfusion of the coronary vein.

7. The apparatus of claim 6 wherein said graft is positioned subcutaneously following suturing to the artery.

-23-

8. The apparatus of claim 1 further comprising a catheter for inserting into the artery to access the oxygenated blood and a connecting tube that is attached between said catheter and said proximal end portion of said cannula.

9. The apparatus of claim 8 wherein said catheter and said proximal end portion of said cannula extend percutaneously and said connecting tube lies above the skin.

10. The apparatus of claim 1 wherein said intraluminal cannula includes a plurality of lumens.

11. The apparatus of claim 10 wherein said distal end portion of said cannula includes a plurality of openings, each of said plurality of openings being fluidly connected with a respective one of said plurality of lumens in said cannula.

12. The apparatus of claim 1 further including a removable sheath for enclosing said intraluminal cannula during insertion of said distal end portion into the coronary vein.



-24-

13. An apparatus for automatically retroperfusing a coronary vein with oxygenated blood from an artery, said apparatus comprising:

an intraluminal cannula having a main body portion extending between a proximal end portion and a distal end portion, said proximal end portion for connecting to an artery to automatically supply oxygenated blood from the artery for retroperfusion of the coronary vein;

said main body portion and said distal end portion being insertable through a vein that is fluidly connected with the coronary vein to be retroperfused and into the coronary vein;

an expandable stent attached to said distal end portion of said cannula for expanding radially into engagement with the interior wall of the coronary vein to secure the distal end portion at a location within the coronary vein; and

occluding means for at least partially occluding the coronary vein to decrease the back-flow of blood into the right atrium during retroperfusion, said occluding means being disposed within said stent.

14. The apparatus of claim 13 wherein said occluding means comprises an umbrella-shaped membrane defined by an open end and a closed end, said closed end being attached to an outer surface of said distal end portion of said cannula, said open end being attached to said stent so that, when said stent is expanded, said membrane spans a radial distance between the interior wall of the coronary vein and said outer surface of said distal end portion of said cannula.

15. The apparatus of claim 14 wherein said membrane includes at least one opening to allow limited blood flow across said membrane.

16. The apparatus of claim 13 wherein said occluding means comprises an inflatable balloon, said balloon having a plurality of lobes disposed circumferentially about said distal end portion of said cannula, said plurality of lobes defining a plurality of radial gaps between said lobes through which a limited quantity of blood may flow.

17. The apparatus of claim 13 wherein said proximal end portion of said cannula comprises a graft for suturing to the artery outside of the pericardium to automatically supply oxygenated blood for retroperfusion of the coronary vein.

18. The apparatus of claim 1 further comprising a catheter for inserting into the artery to access the oxygenated blood and a connecting tube that is attached between said catheter and said proximal end portion of said cannula.

19. The apparatus of claim 13 wherein said intraluminal cannula includes a plurality of lumens.

20. The apparatus of claim 19 wherein said distal end portion of said cannula includes a plurality of openings, each of said plurality of openings being fluidly connected with a respective one of said plurality of lumens in said cannula.

21. The apparatus of claim 1 further including a removable sheath for enclosing said intraluminal cannula during insertion of said distal end portion into the coronary vein.

22. A method for automatically retroperfusing a coronary vein with oxygenated blood from an artery, said method comprising the steps of:

- providing an intraluminal cannula having a main body portion extending between a proximal end portion and a distal end portion, the distal end portion including an expandable stent and occluding means for at least partially occluding the coronary vein;
- inserting the main body portion and the distal end portion of the cannula through a vein that is fluidly connected with the coronary vein to be retroperfused and into the coronary vein;
- radially expanding the stent into engagement with the interior wall of the coronary vein to secure the distal end portion at a location within the coronary vein, wherein the radial expansion of the stent causes the occluding means to span the coronary vein; and

-27-

fluidly connecting the proximal end portion of the cannula to an artery to automatically supply oxygenated blood for retroperfusion, wherein the occluding means at least partially occludes the coronary vein to decrease the back-flow of blood into the right atrium during retroperfusion.

23. The method of claim 22 wherein said step of fluidly connecting the proximal end portion to an artery comprises suturing a graft located at the proximal end portion to the artery outside of the pericardium.

24. The method of claim 23 further comprising the step of positioning the graft subcutaneously following suturing to the artery.

25. The method of claim 22 wherein said step of fluidly connecting the proximal end portion to an artery comprises the steps of:  
inserting a catheter into the artery to access the oxygenated blood; and  
attaching a connecting tube between the catheter and said proximal end portion of the cannula.

26. The method of claim 25 further comprising the step of extending the catheter and the proximal end portion of said cannula in a percutaneous manner and positioning the connecting tube above the skin.

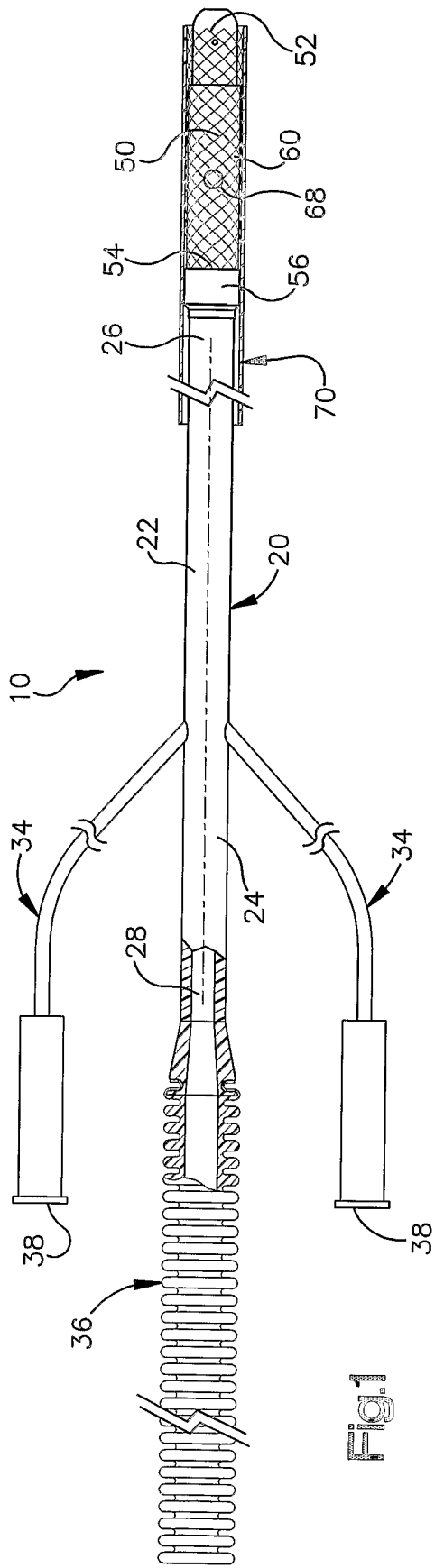

Fig.1

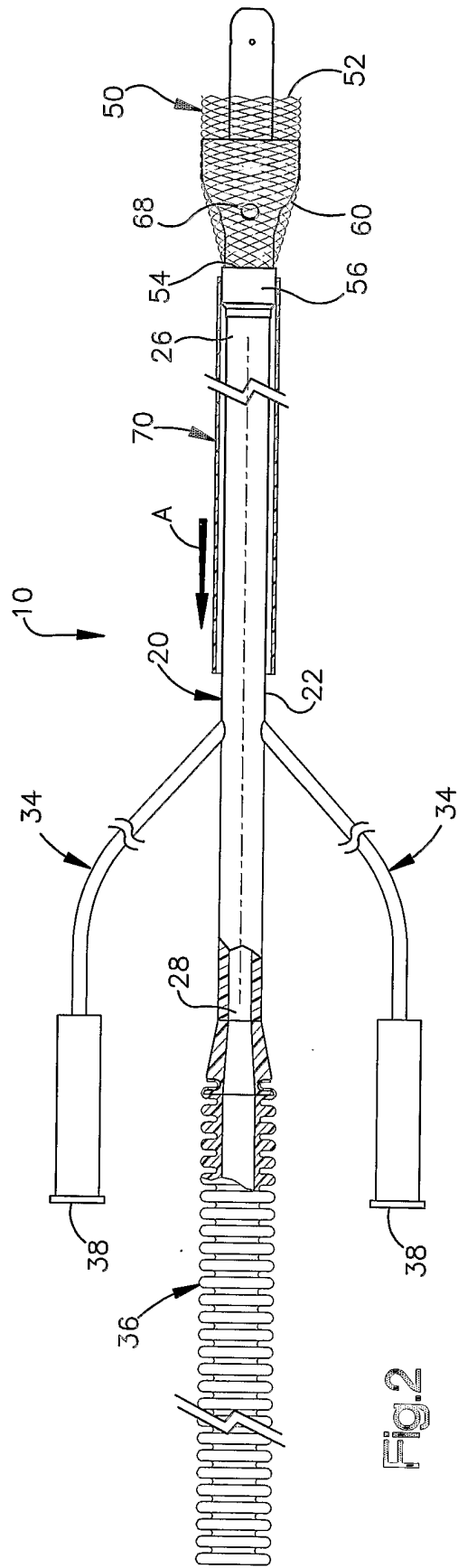

Fig.2

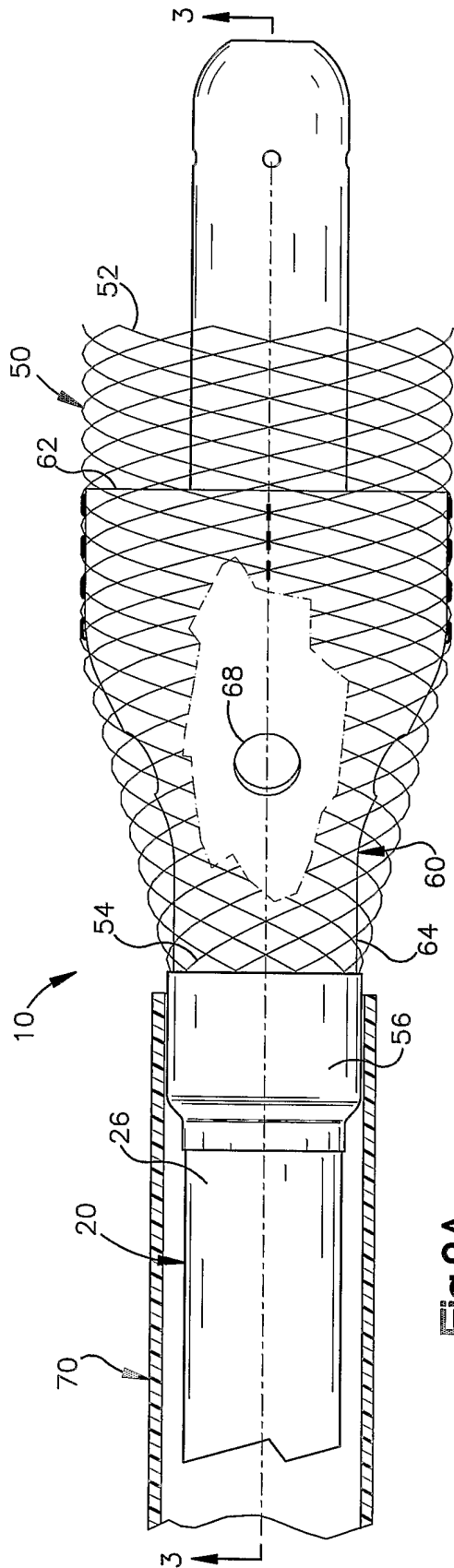

Fig.2A

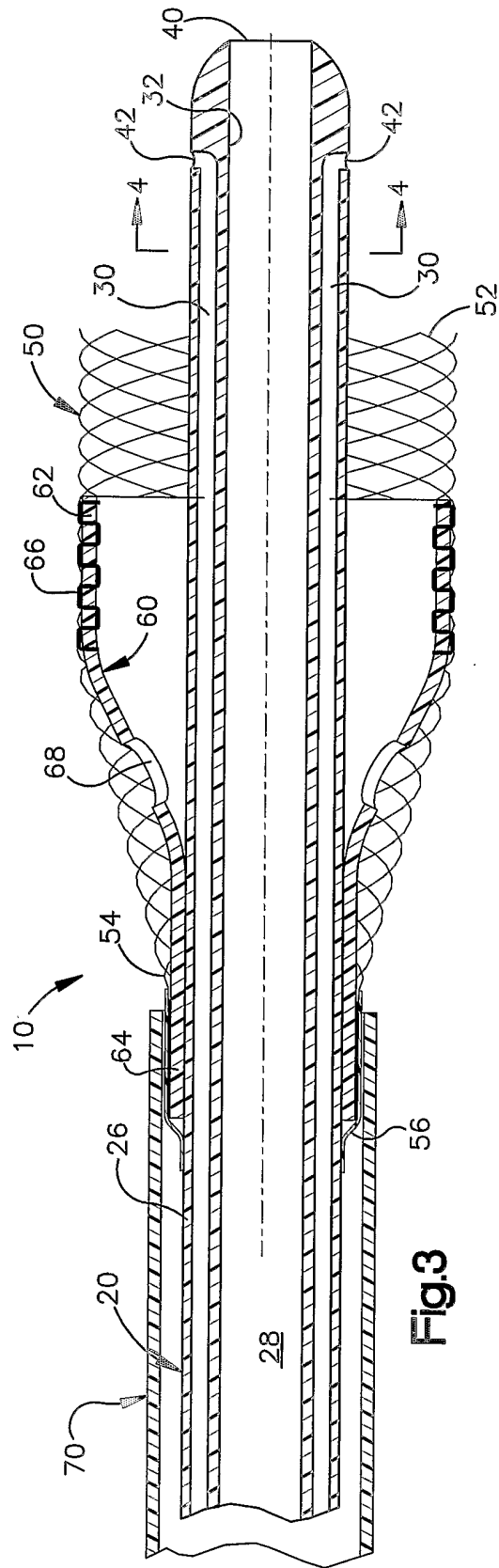

Fig.3

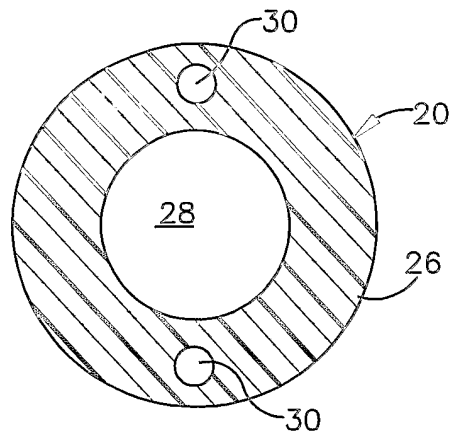

Fig.4

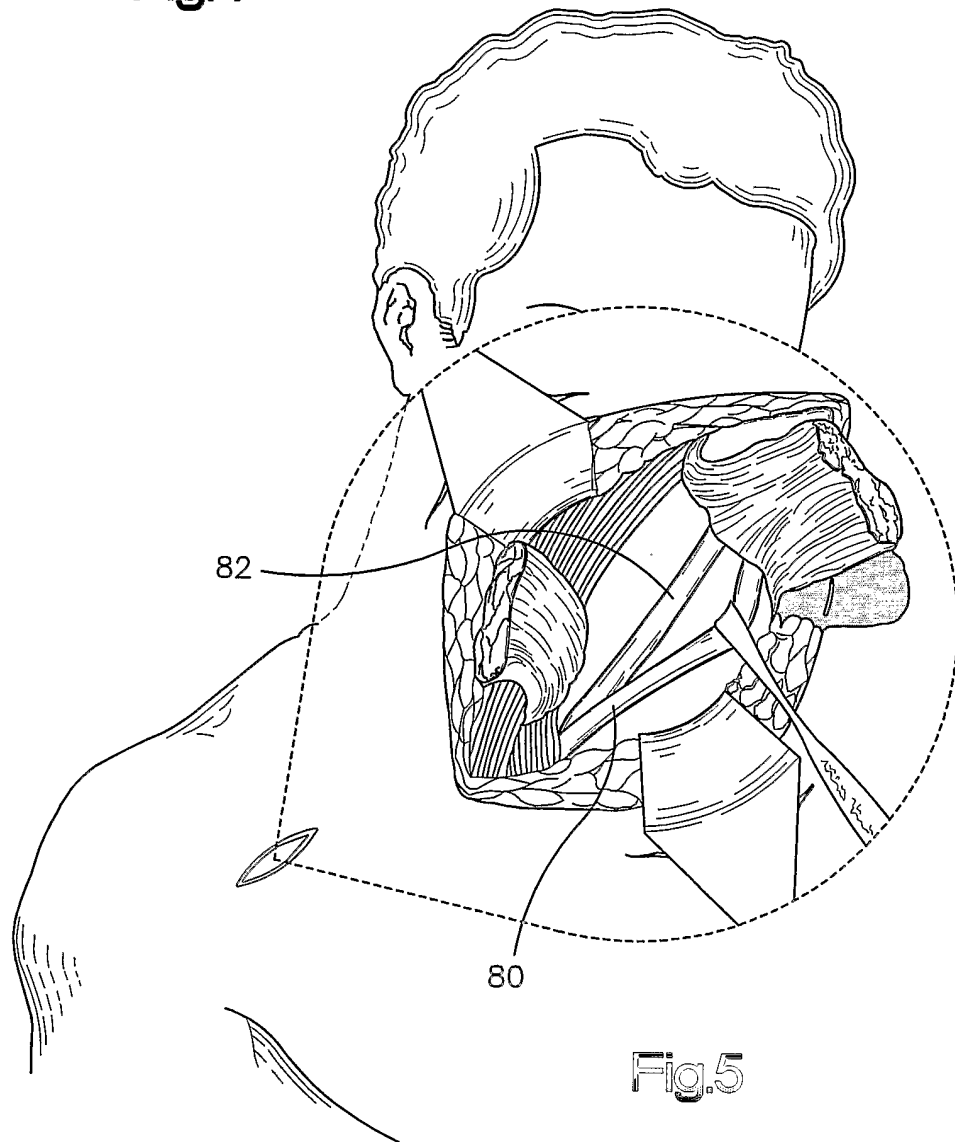

Fig.5

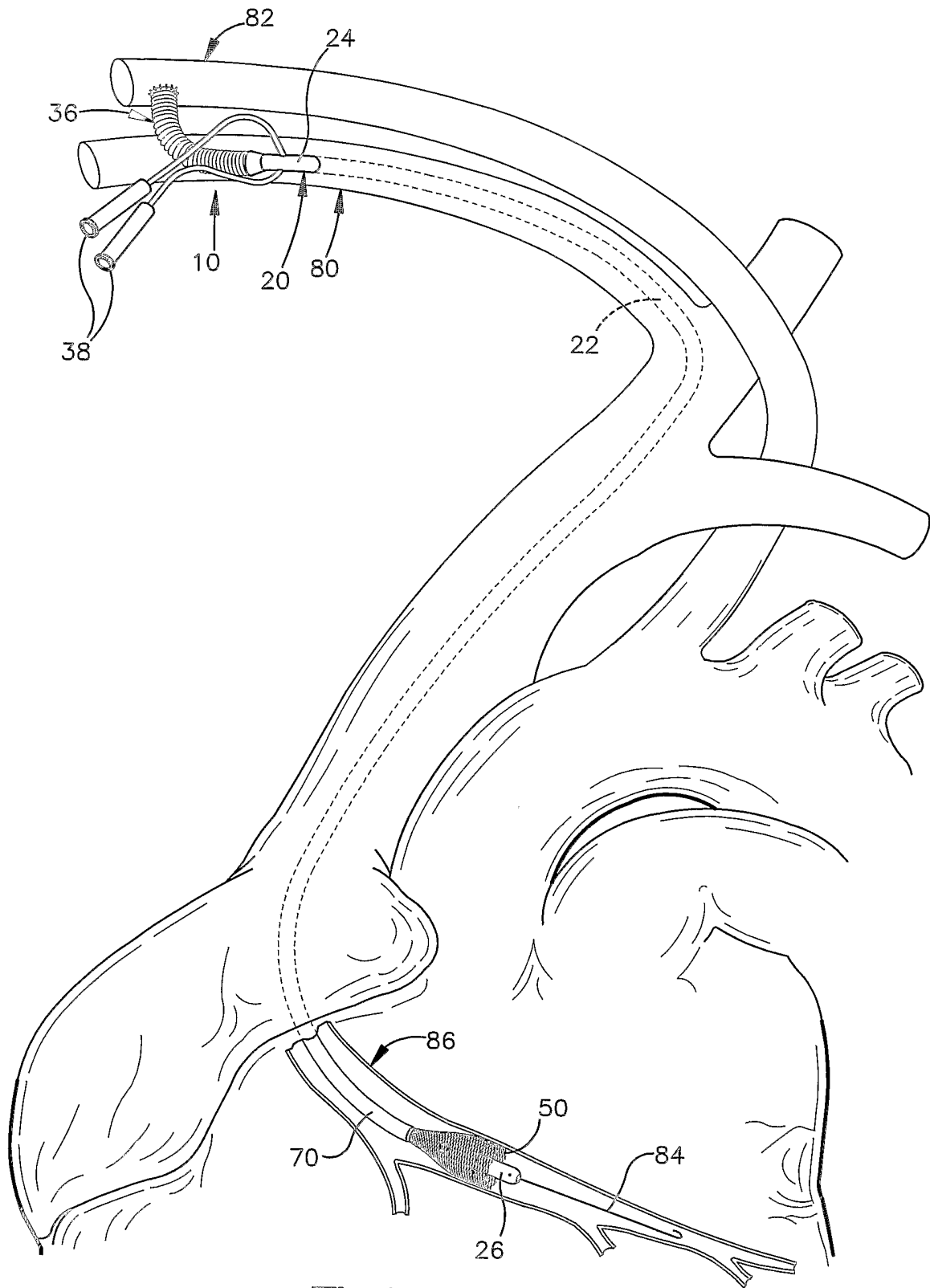

Fig.6



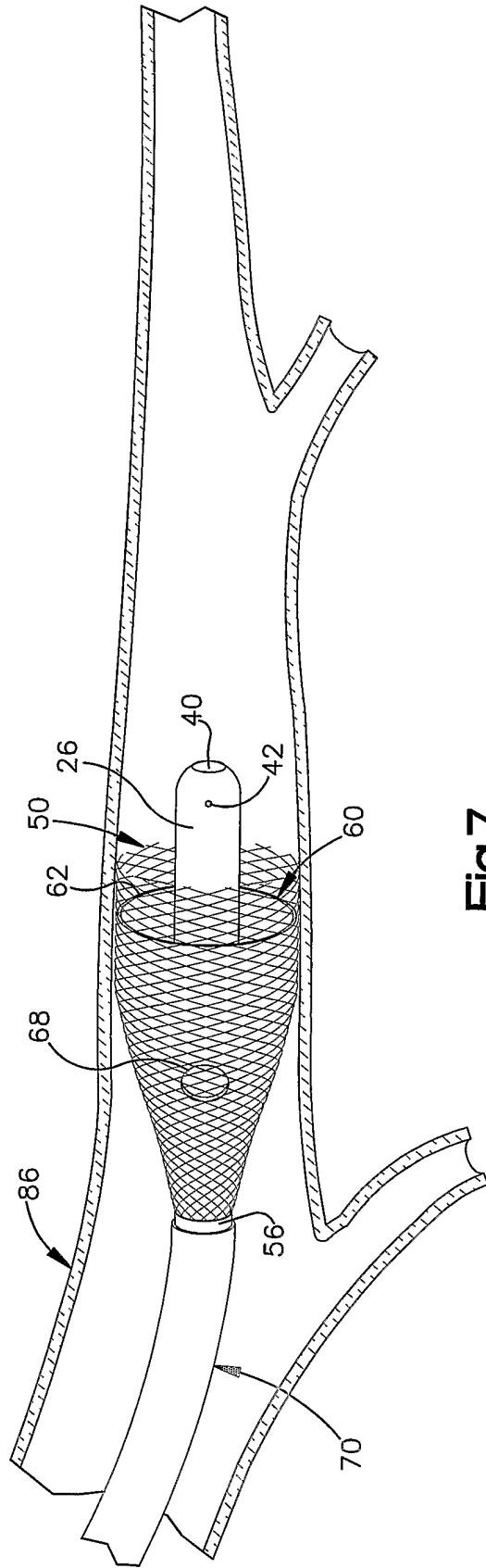

Fig.7

6/10

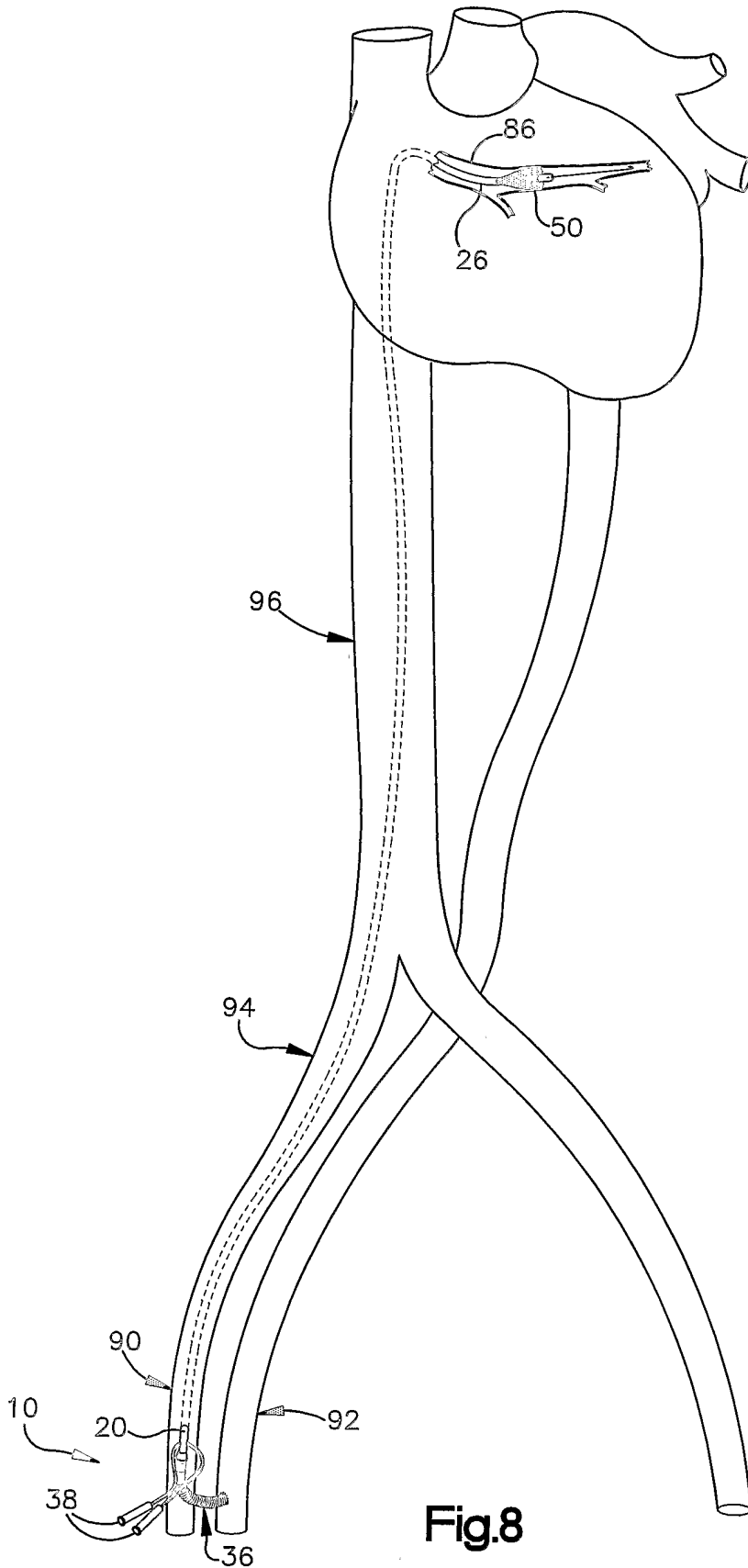

Fig.8

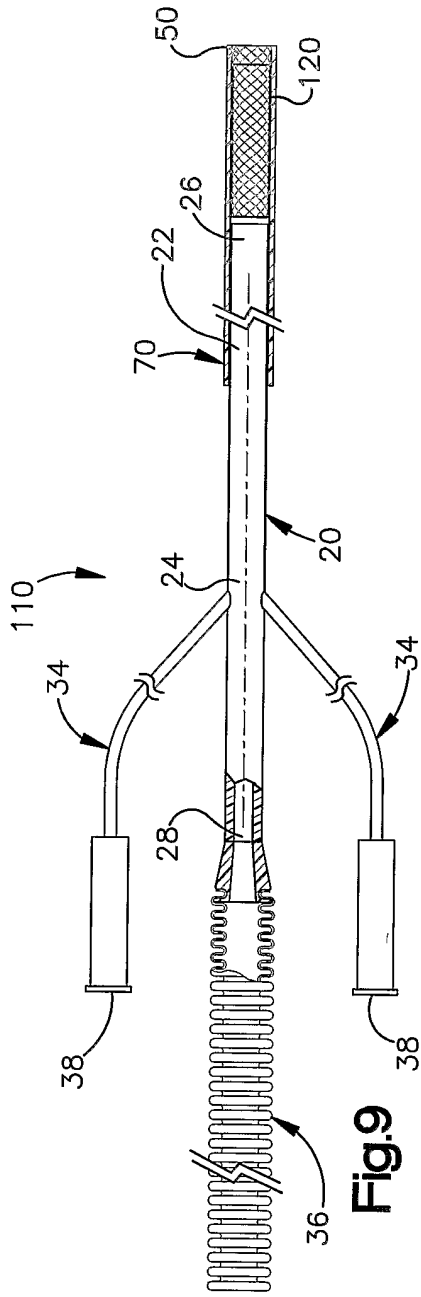

Fig. 9

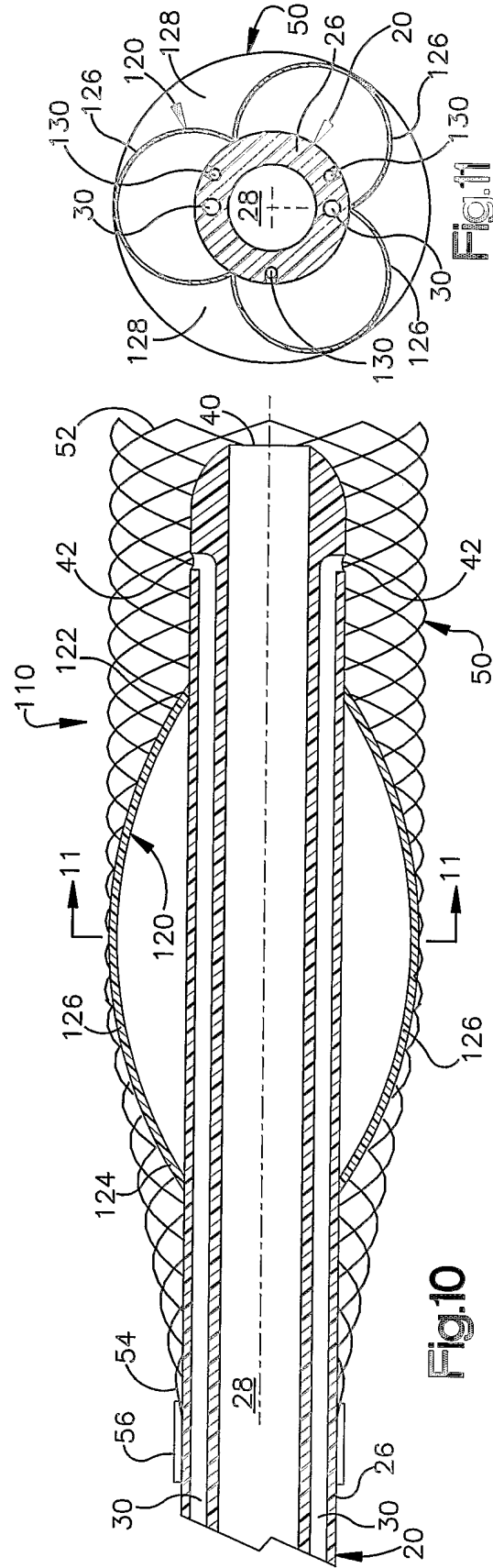

Fig. 10

Fig. 11

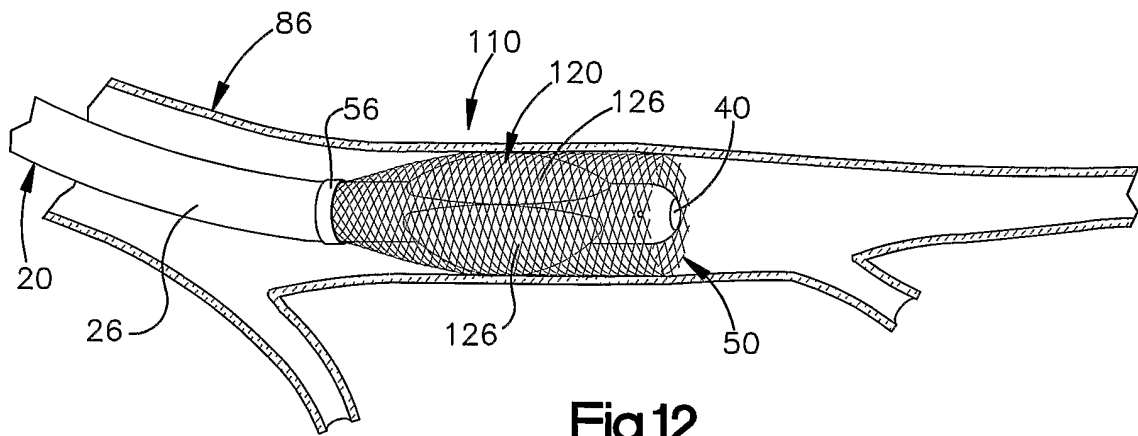

Fig.12

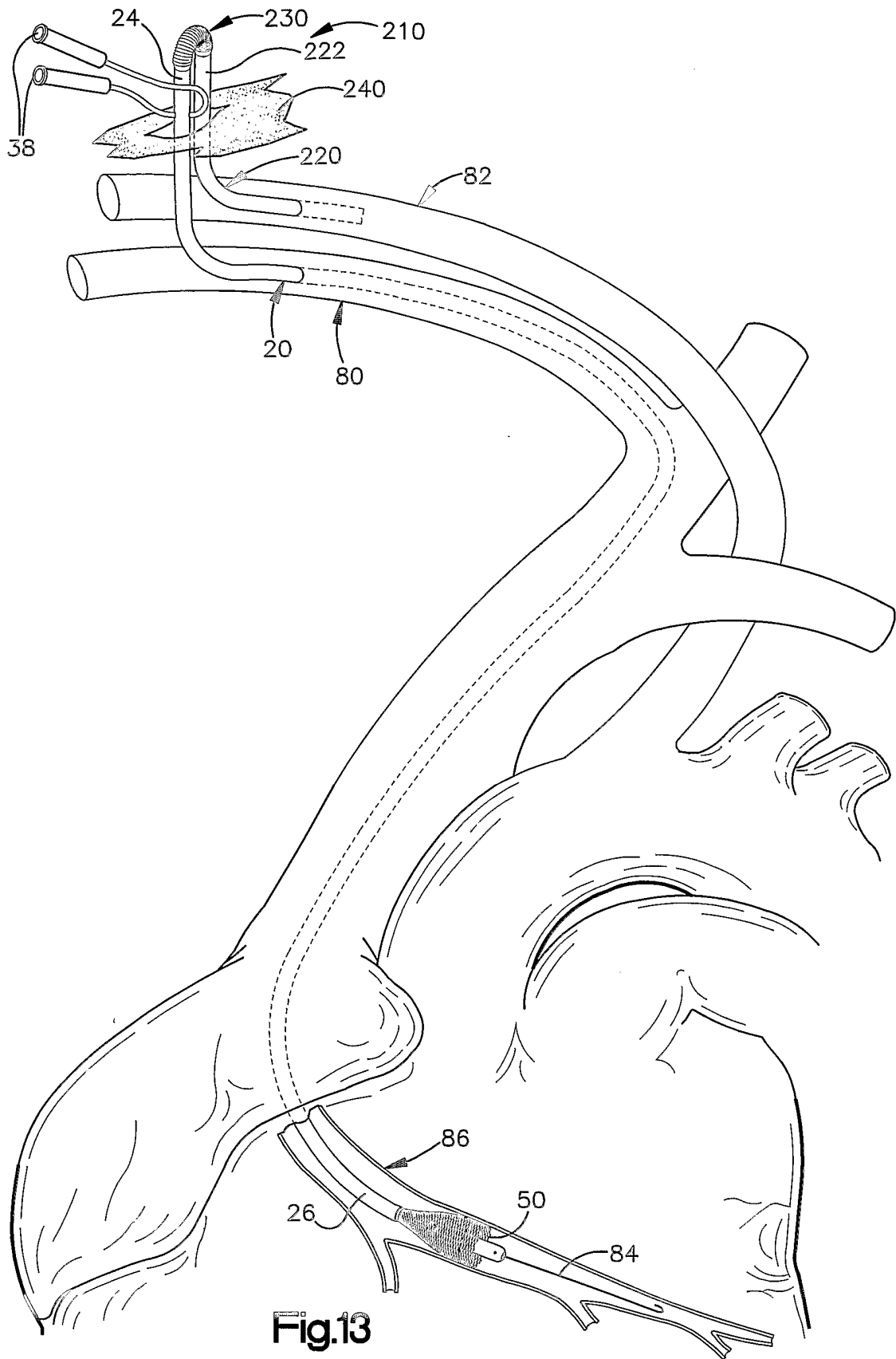

Fig.13

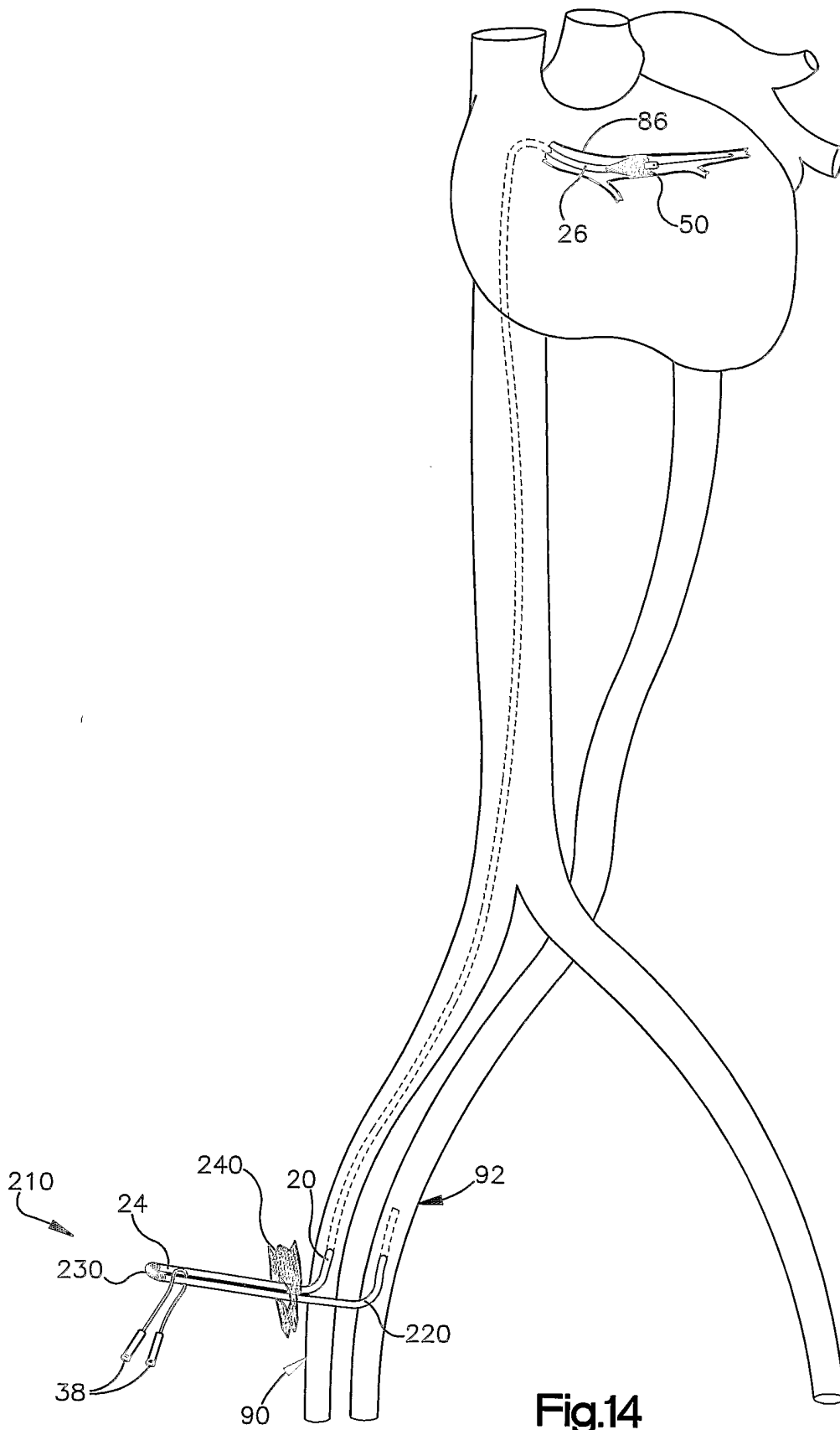

Fig.14