



US 20070194023A1

(19) **United States**

(12) **Patent Application Publication**
Apps et al.

(10) **Pub. No.: US 2007/0194023 A1**

(43) **Pub. Date: Aug. 23, 2007**

(54) **CONTAINER**

Publication Classification

(76) Inventors: **William P. Apps**, Alpharetta, GA (US);
Mauricio D. Cavalcante, Playa Del
Ray, CA (US)

(51) **Int. Cl.**
B65D 6/00 (2006.01)
B65D 6/28 (2006.01)
(52) **U.S. Cl.** **220/6; 220/600**

Correspondence Address:
CARLSON, GASKEY & OLDS, P.C.
400 WEST MAPLE ROAD
SUITE 350
BIRMINGHAM, MI 48009 (US)

(57) **ABSTRACT**

A collapsible container includes a plurality of walls collapsible onto the base. At least one wall has a support for supporting a second container thereon. The support is pivotably mounted to or integrally formed with an upper end portion of at least one wall. The pivotably mounted support includes a support structure that is pivotable between a support position where it is partially supported on an adjacent wall and a retracted position. In the retracted position, the wall can be pivoted downward onto the base, with a portion of the support passing through a channel formed on the interior of the adjacent wall. The integrally formed support includes a support structure that is at least partially received within a support channel formed in the base when the container is in the collapsed position.

(21) Appl. No.: **11/687,169**

(22) Filed: **Mar. 16, 2007**

Related U.S. Application Data

(63) Continuation-in-part of application No. 11/264,371, filed on Nov. 1, 2005.

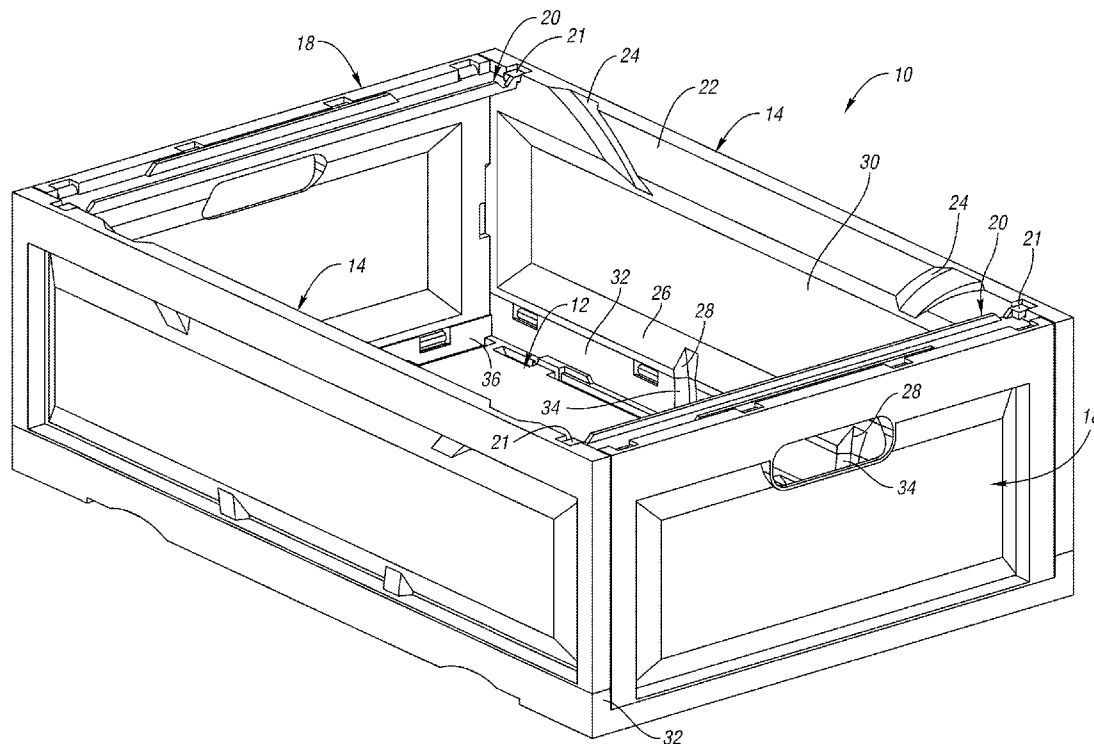

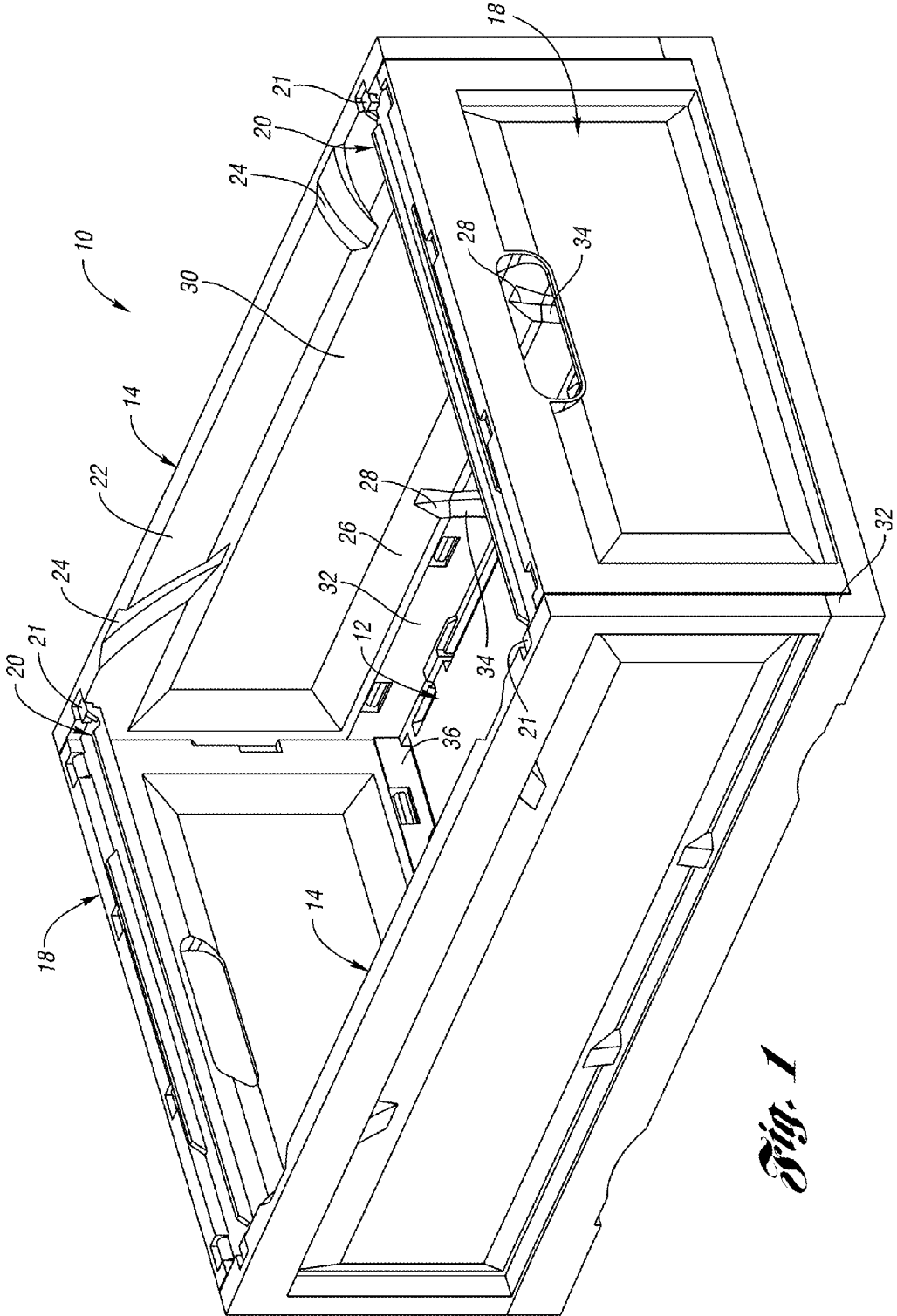

Fig. 1

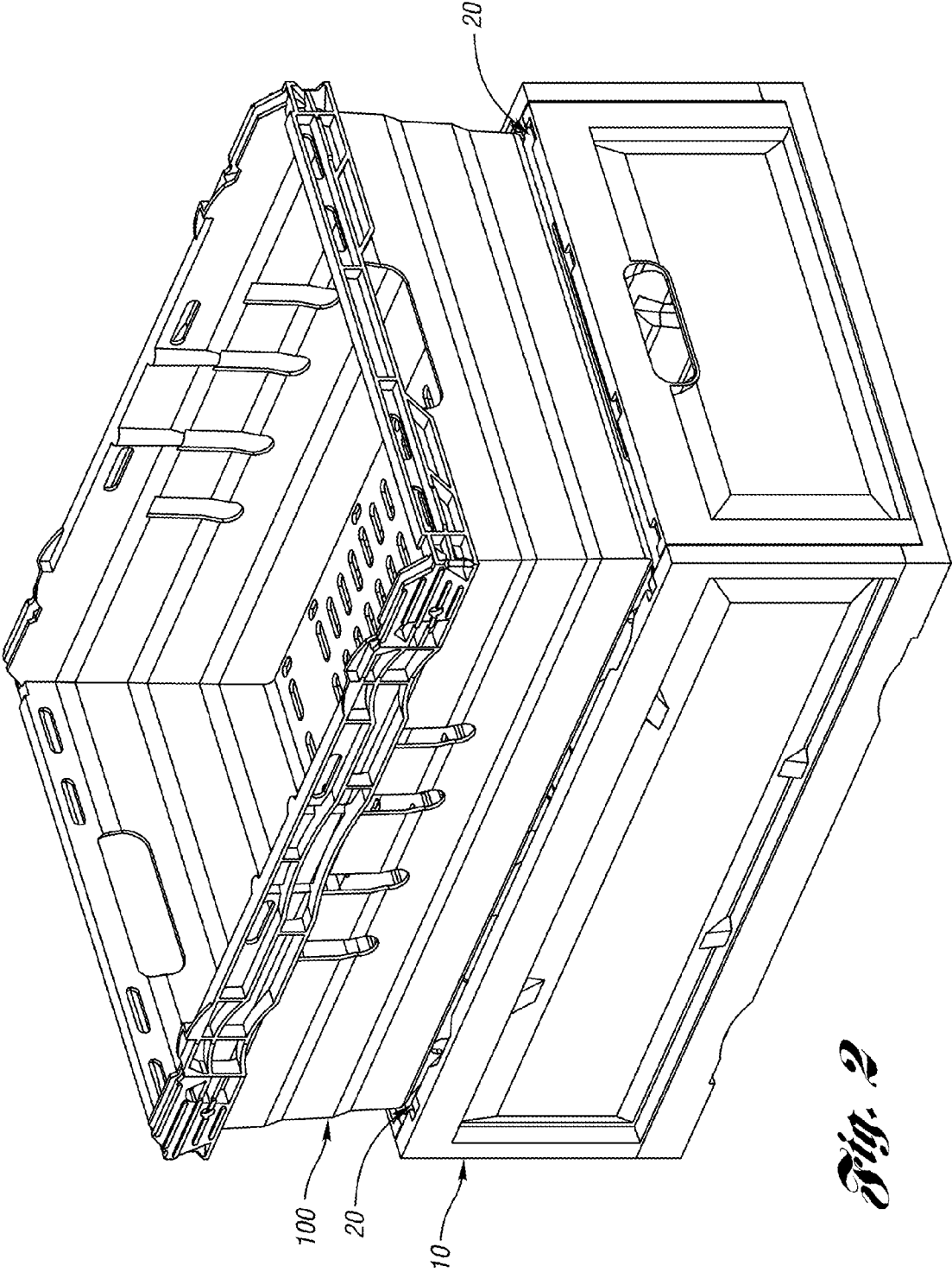

Fig. 2

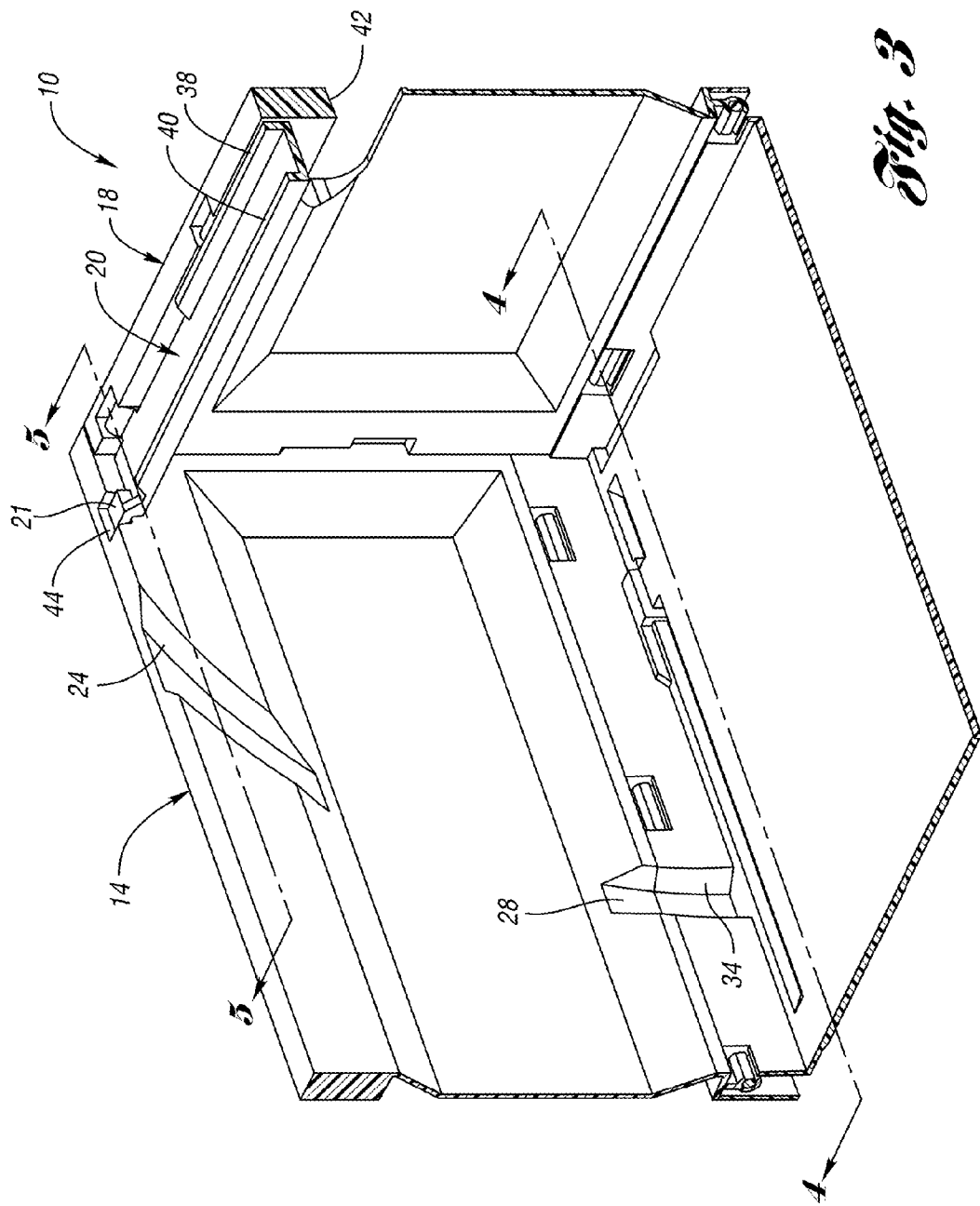

Fig. 3

Fig. 4

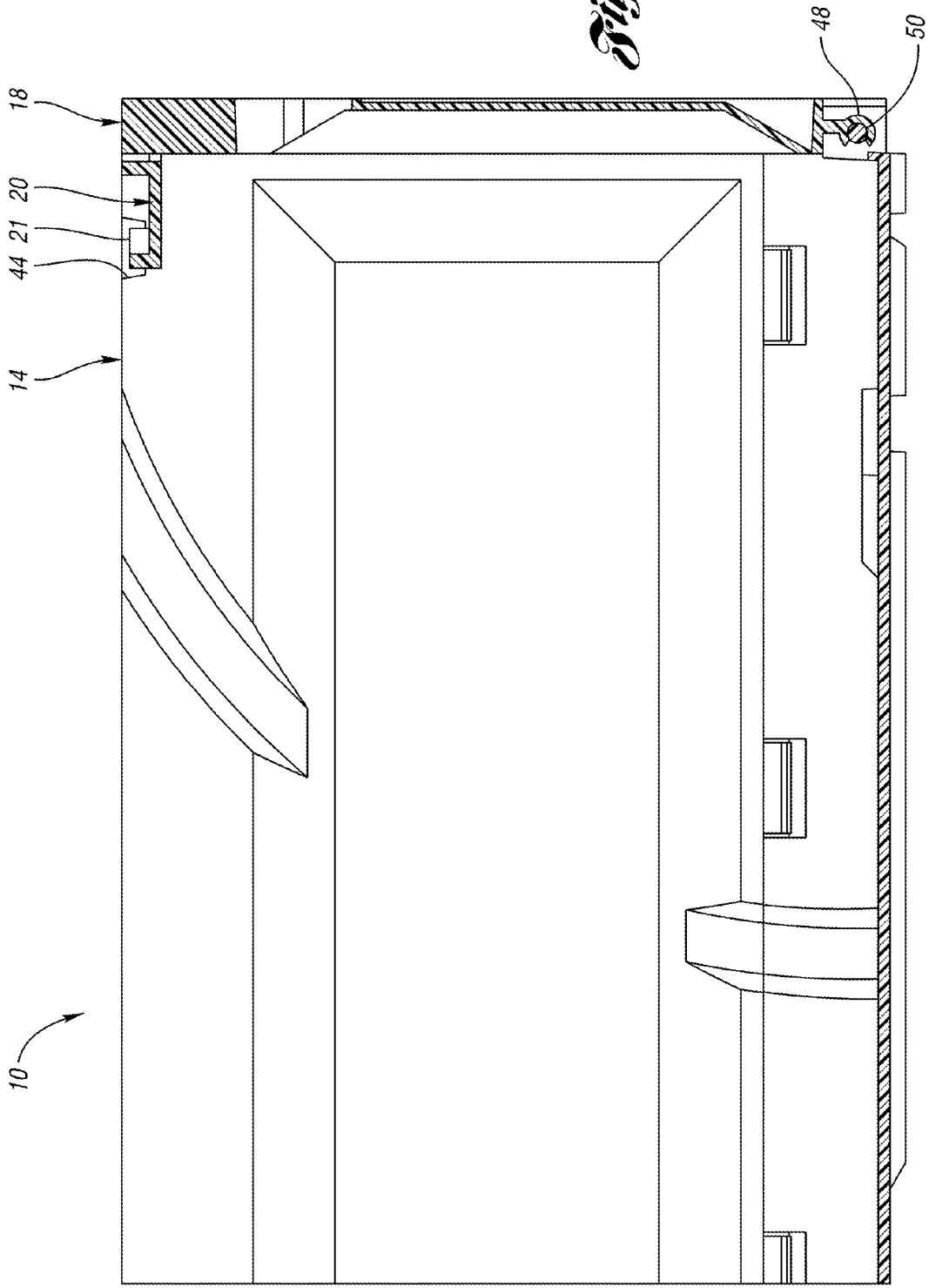
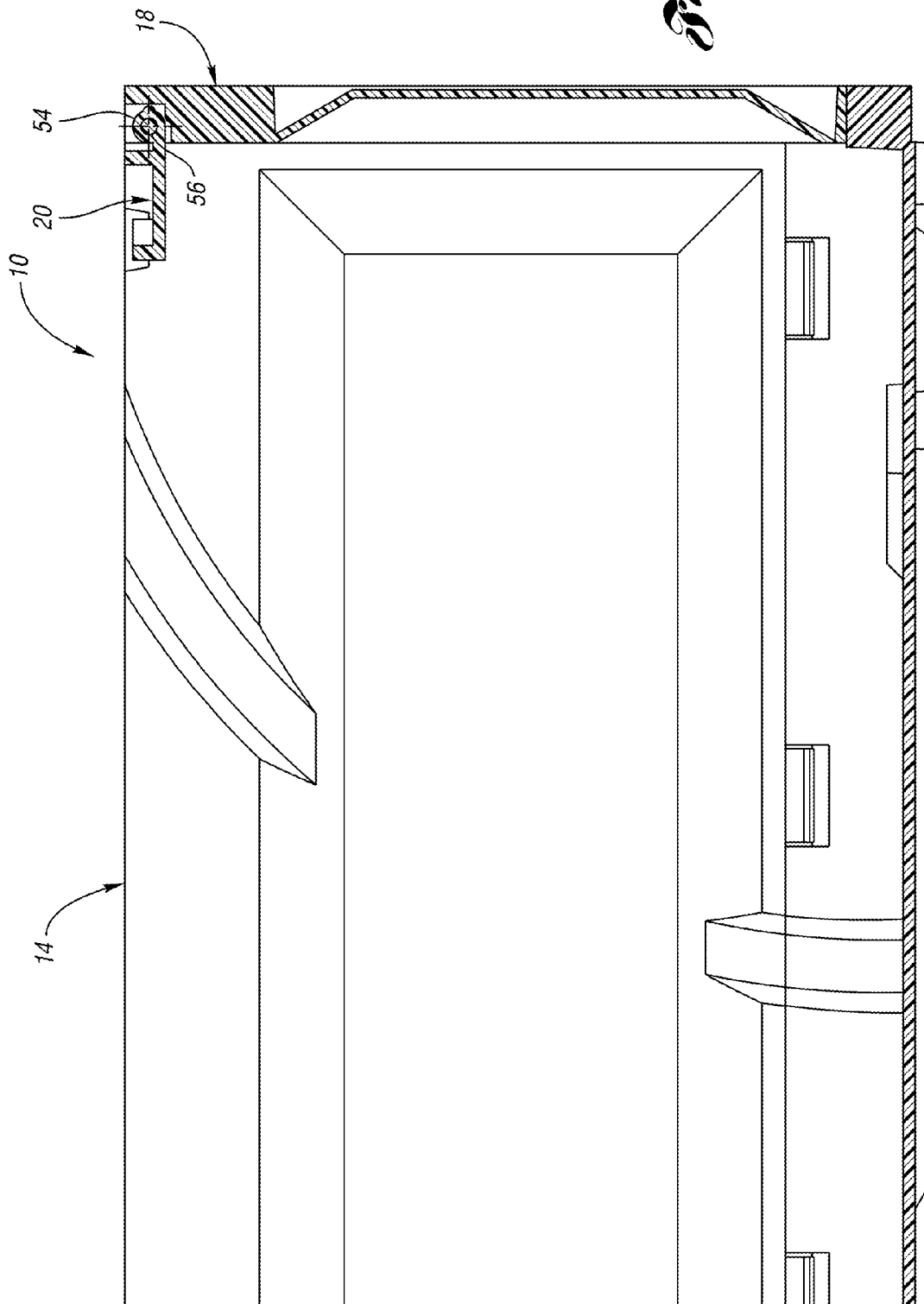

Fig. 5



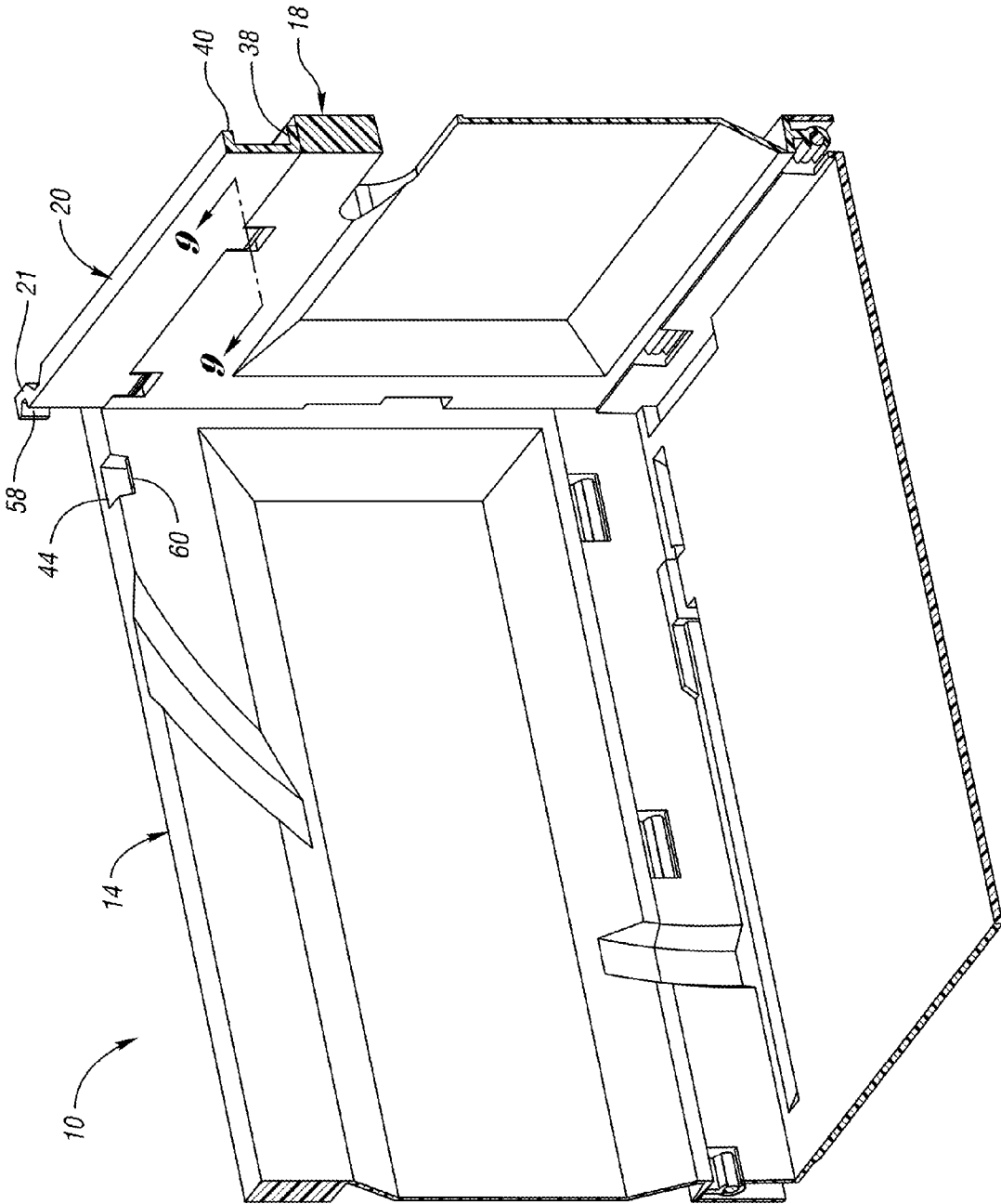

Fig. 6

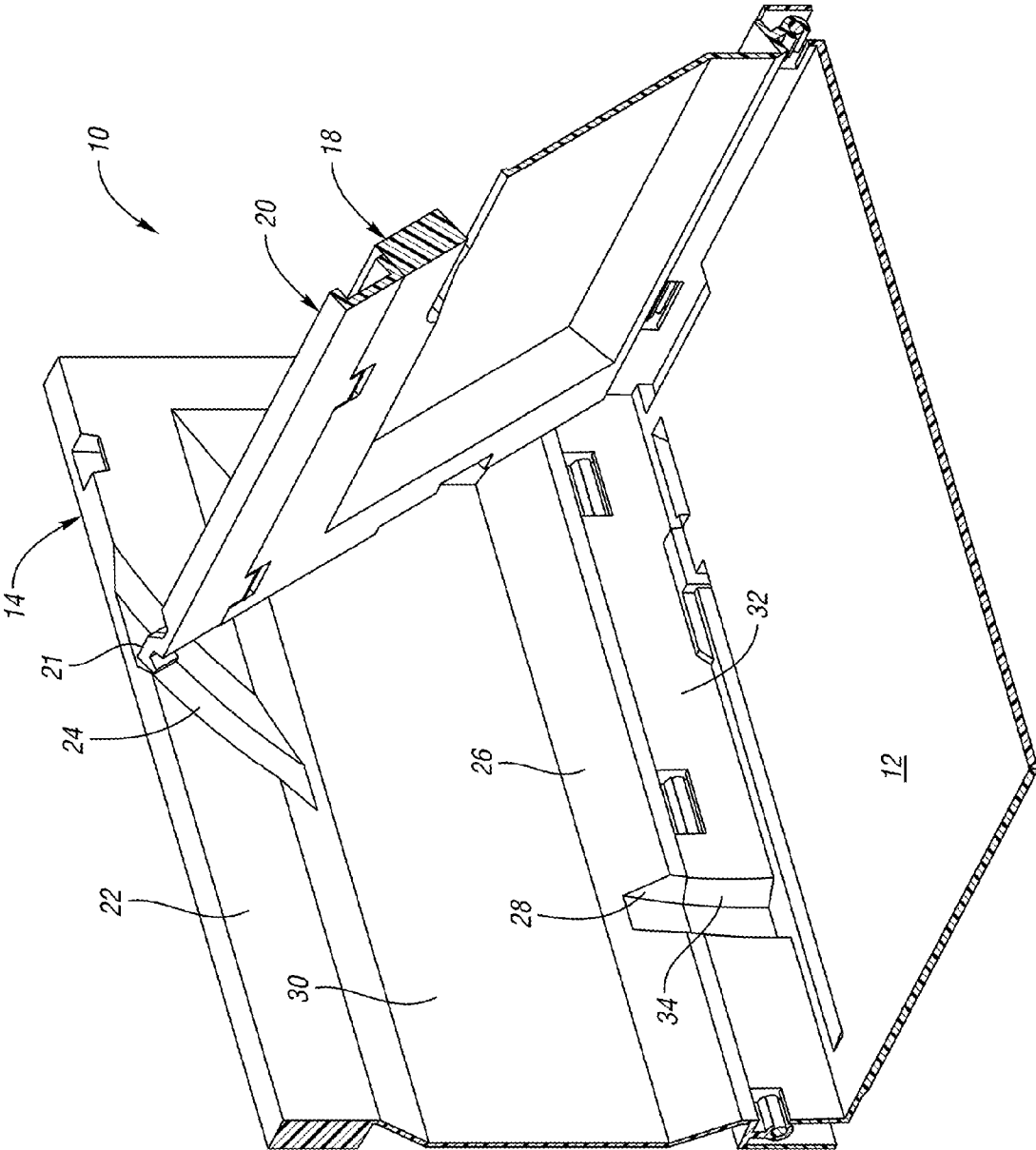
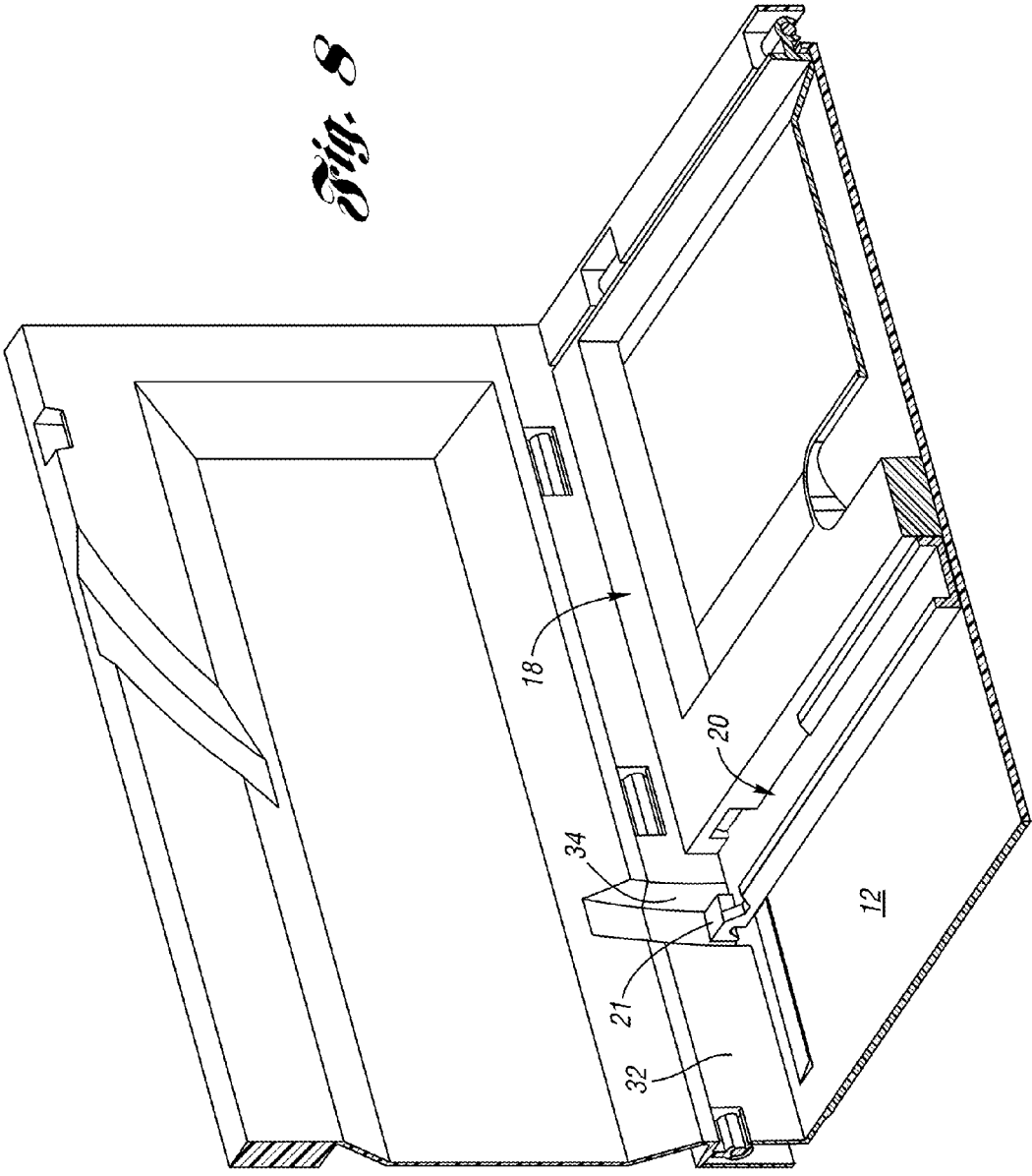
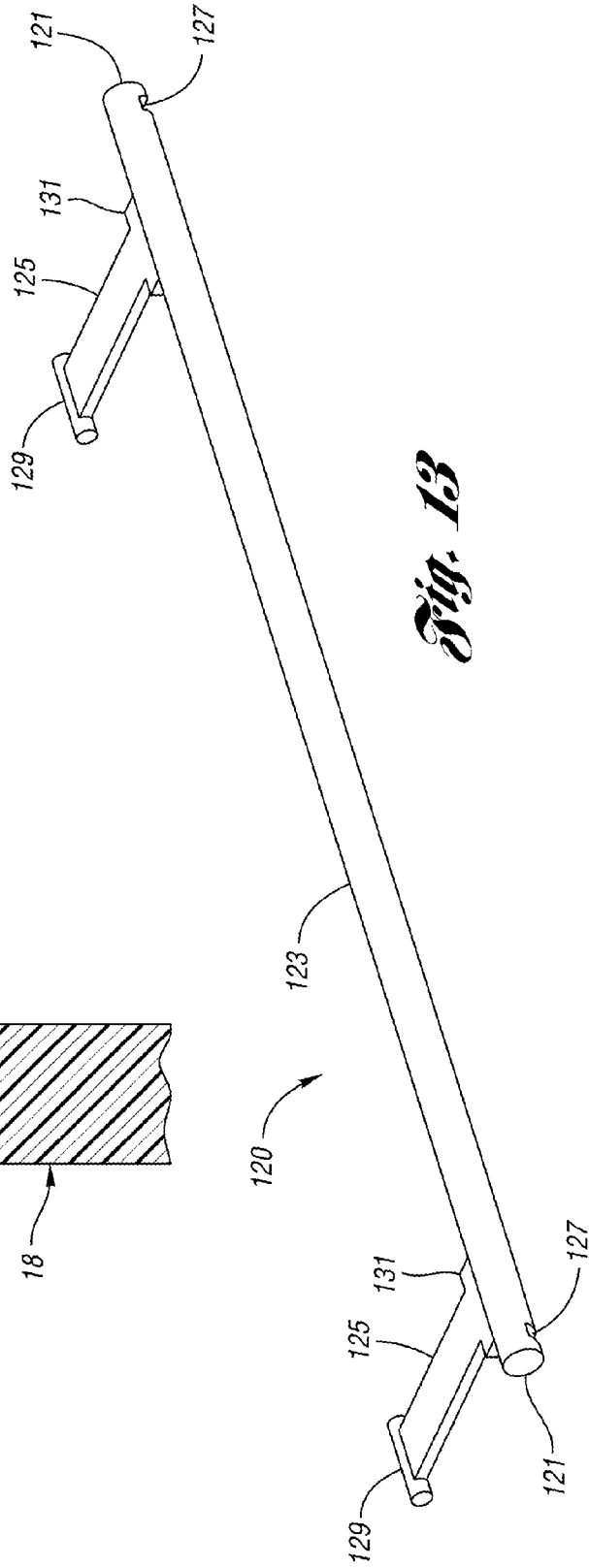
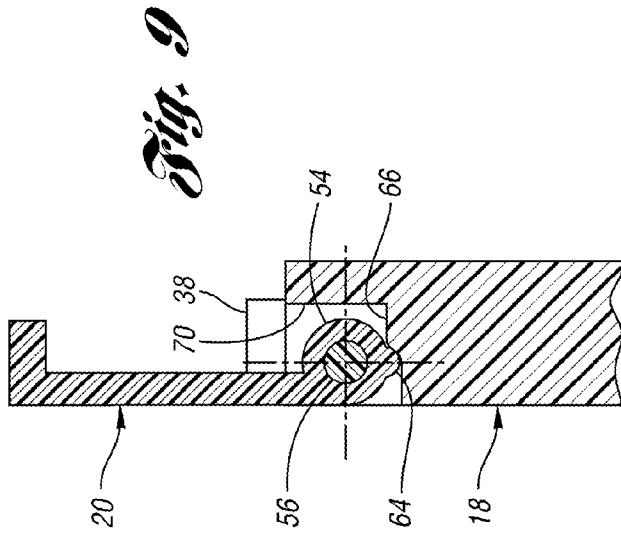

Fig. 7

Fig. 8





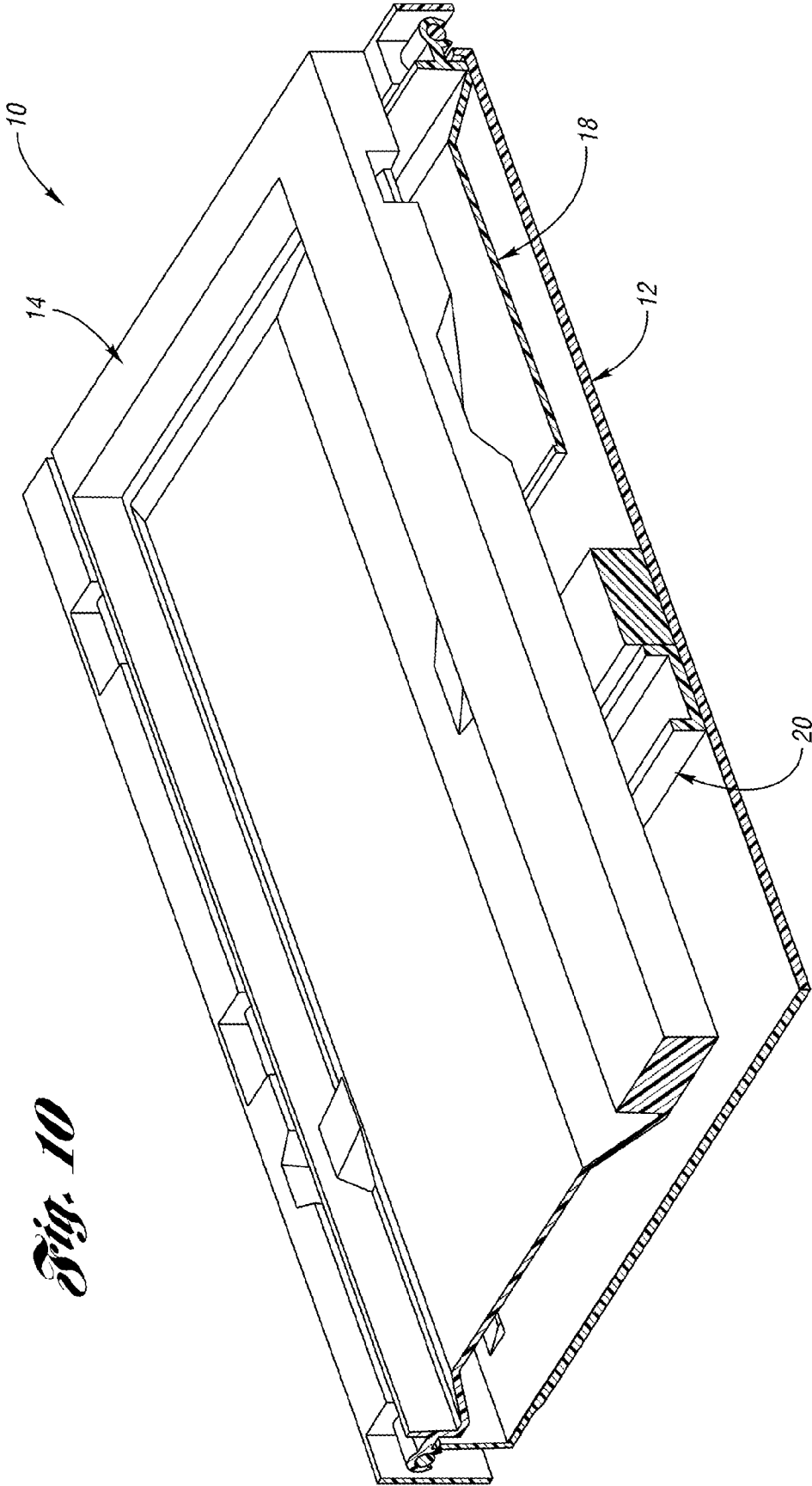

Fig. 10

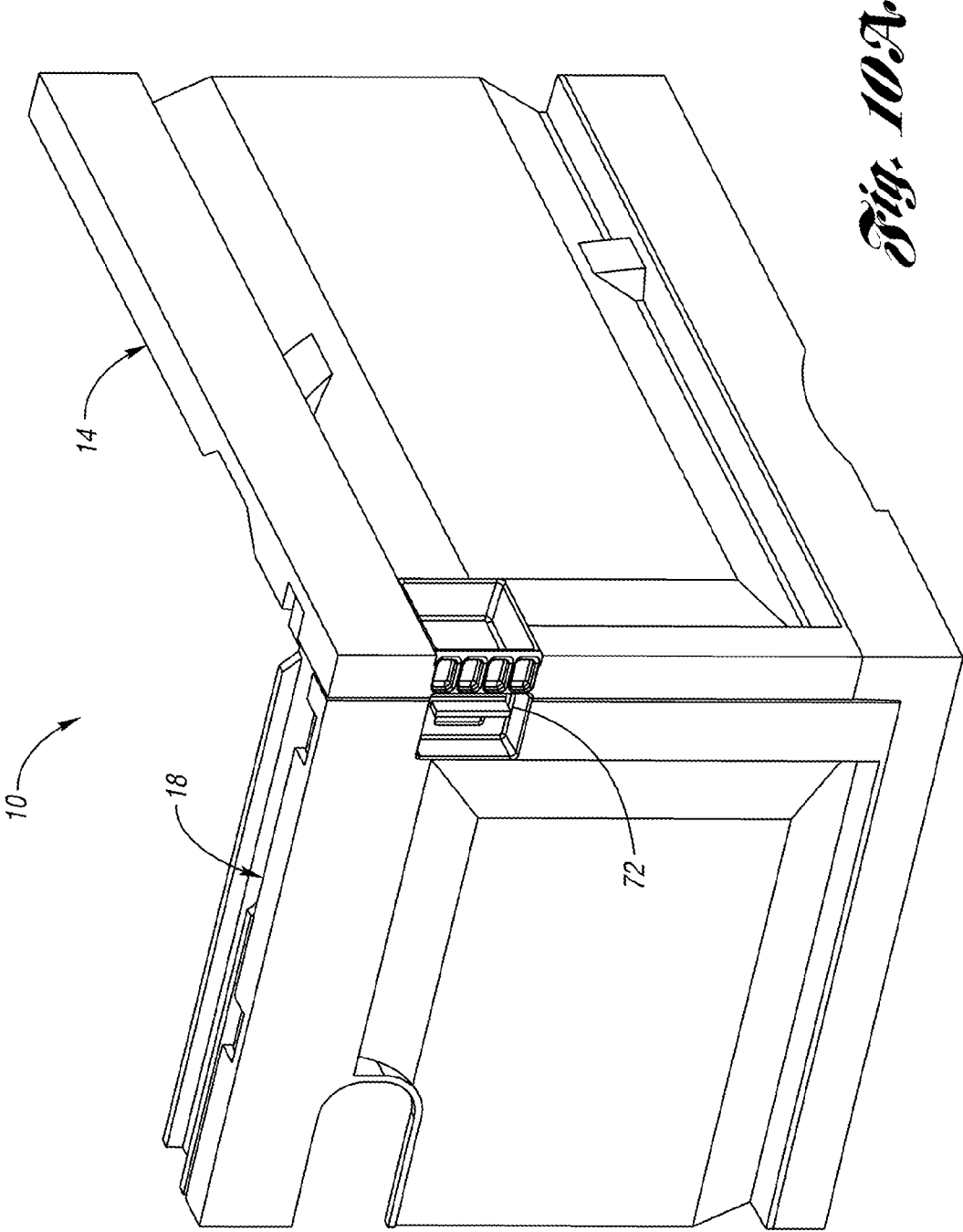

Fig. 10A

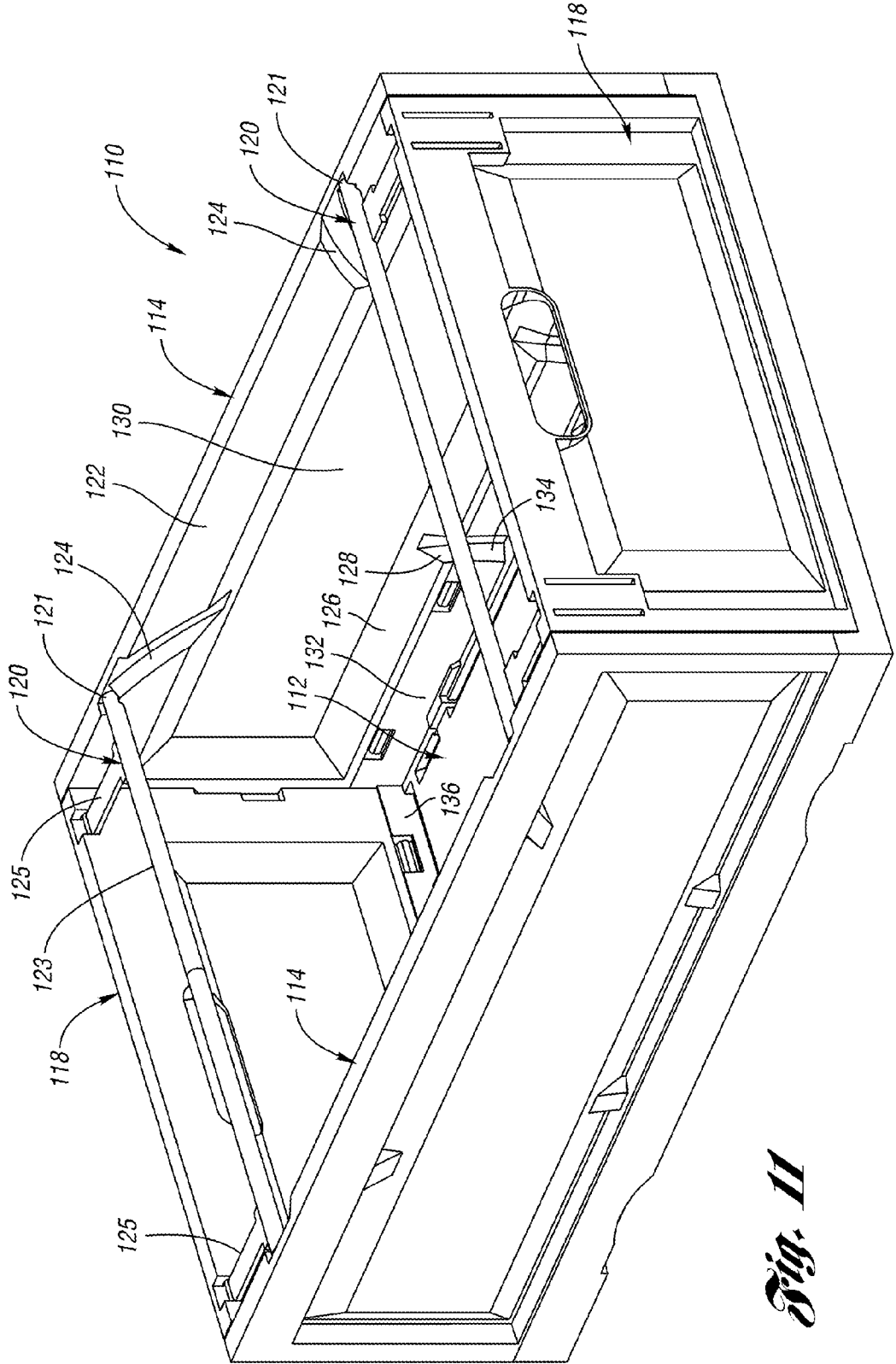

Fig. 11

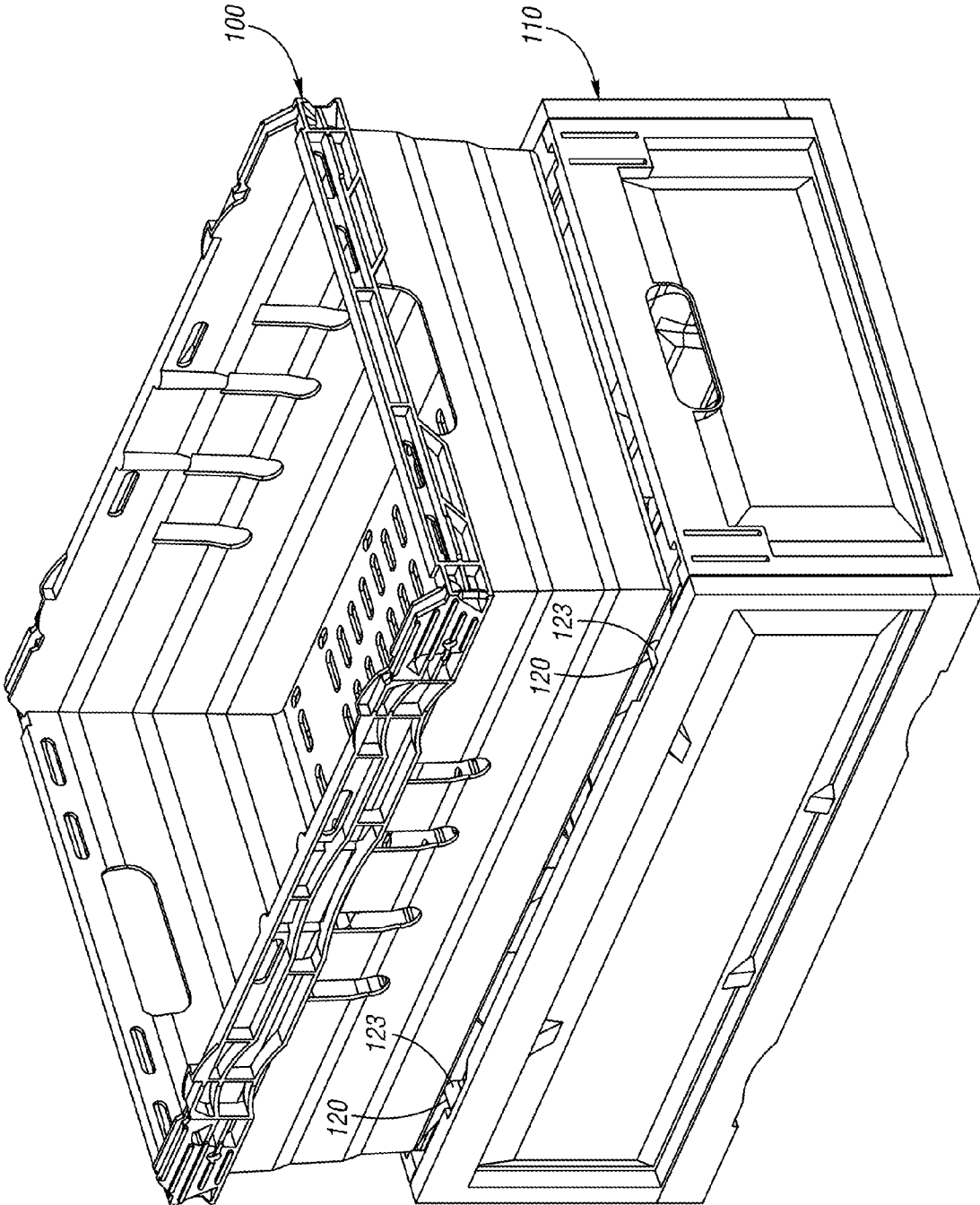

Fig. 12

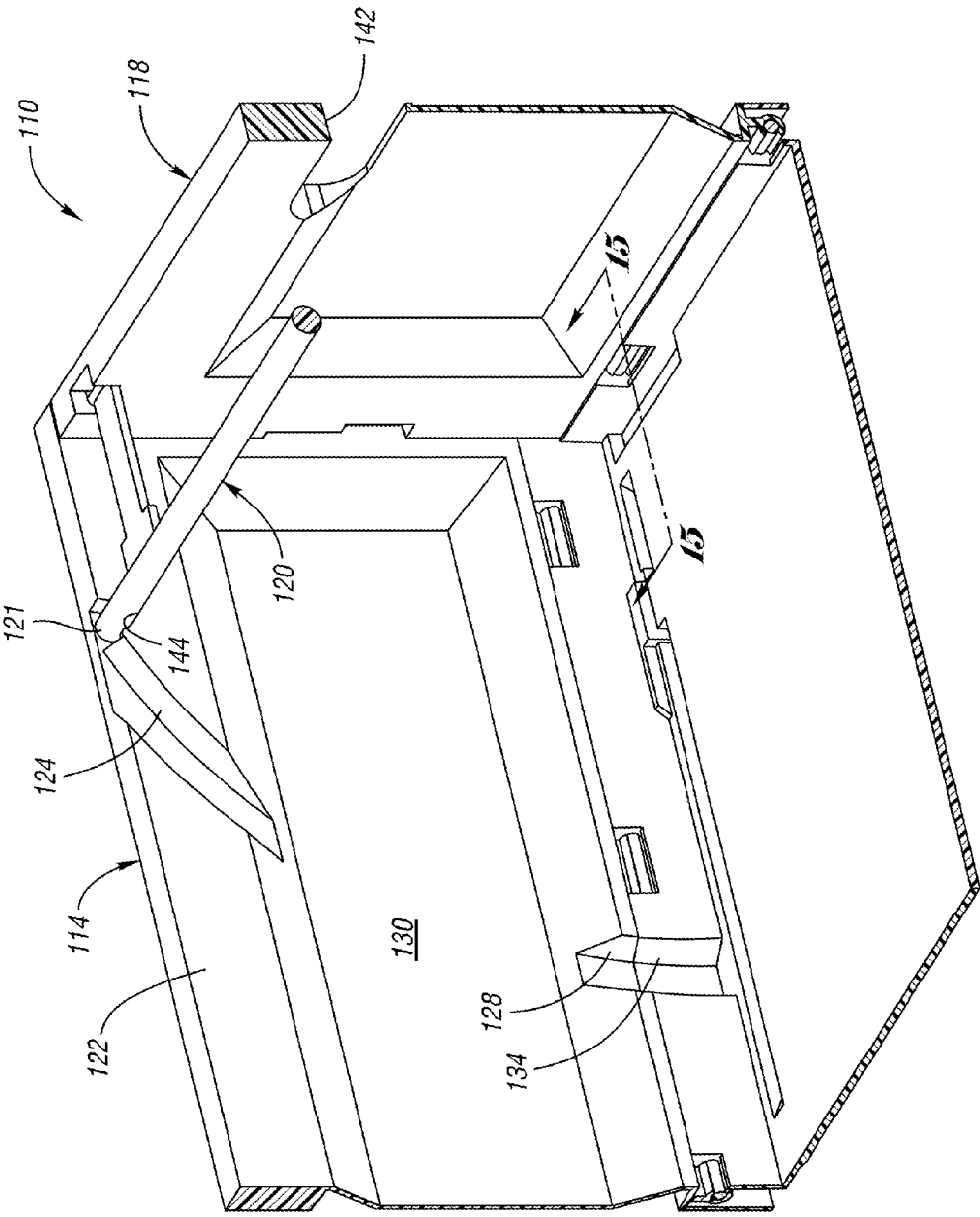

Fig. 14

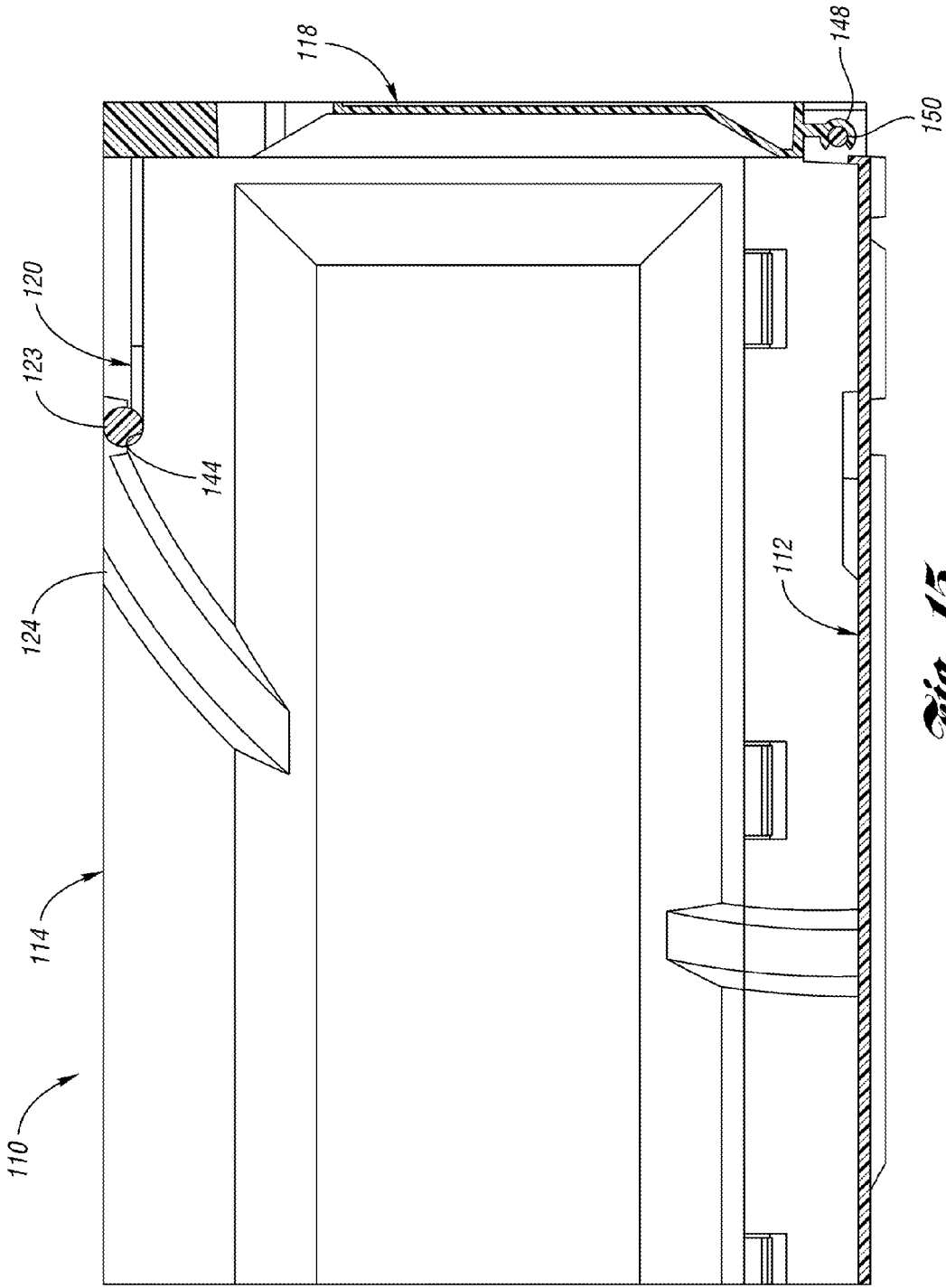

Fig. 15

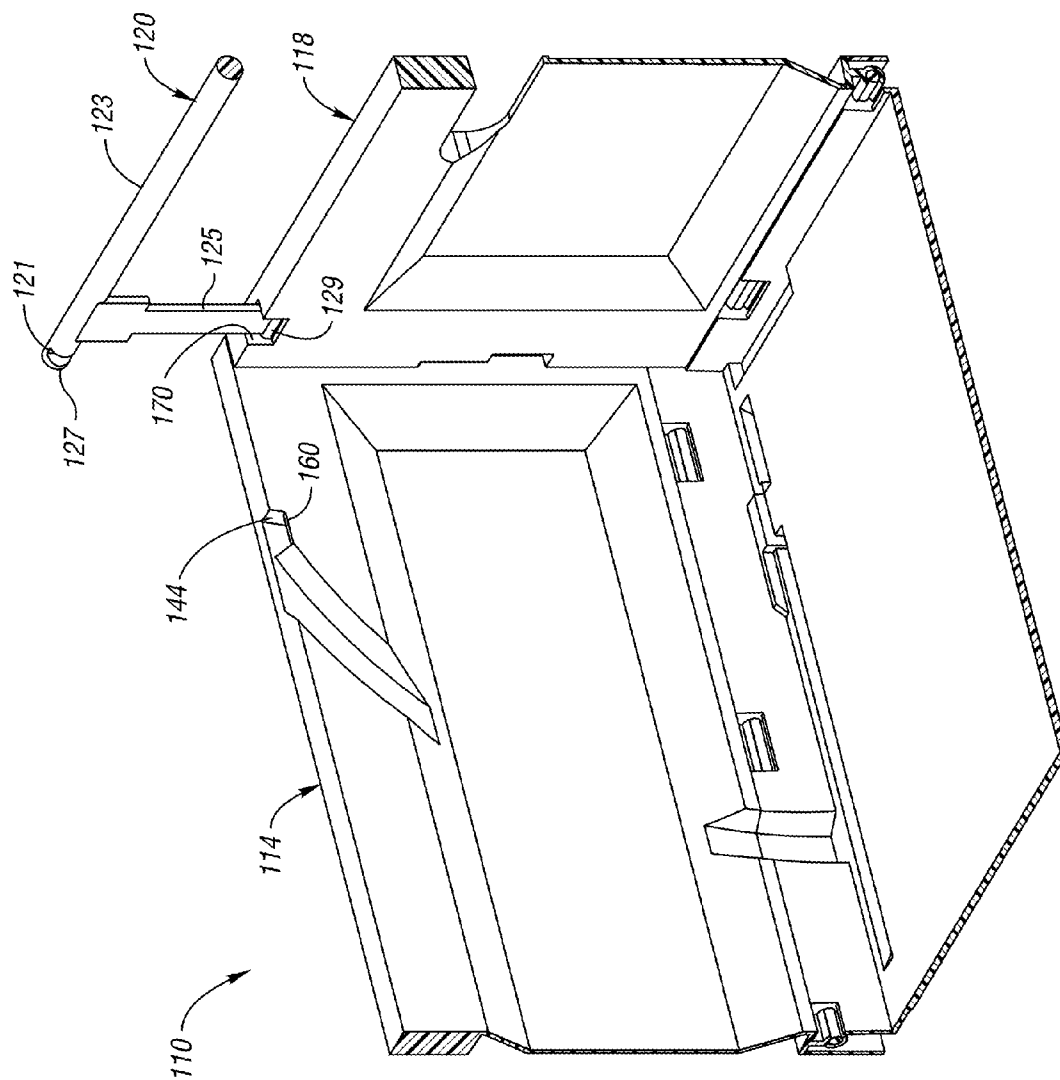

Fig. 16

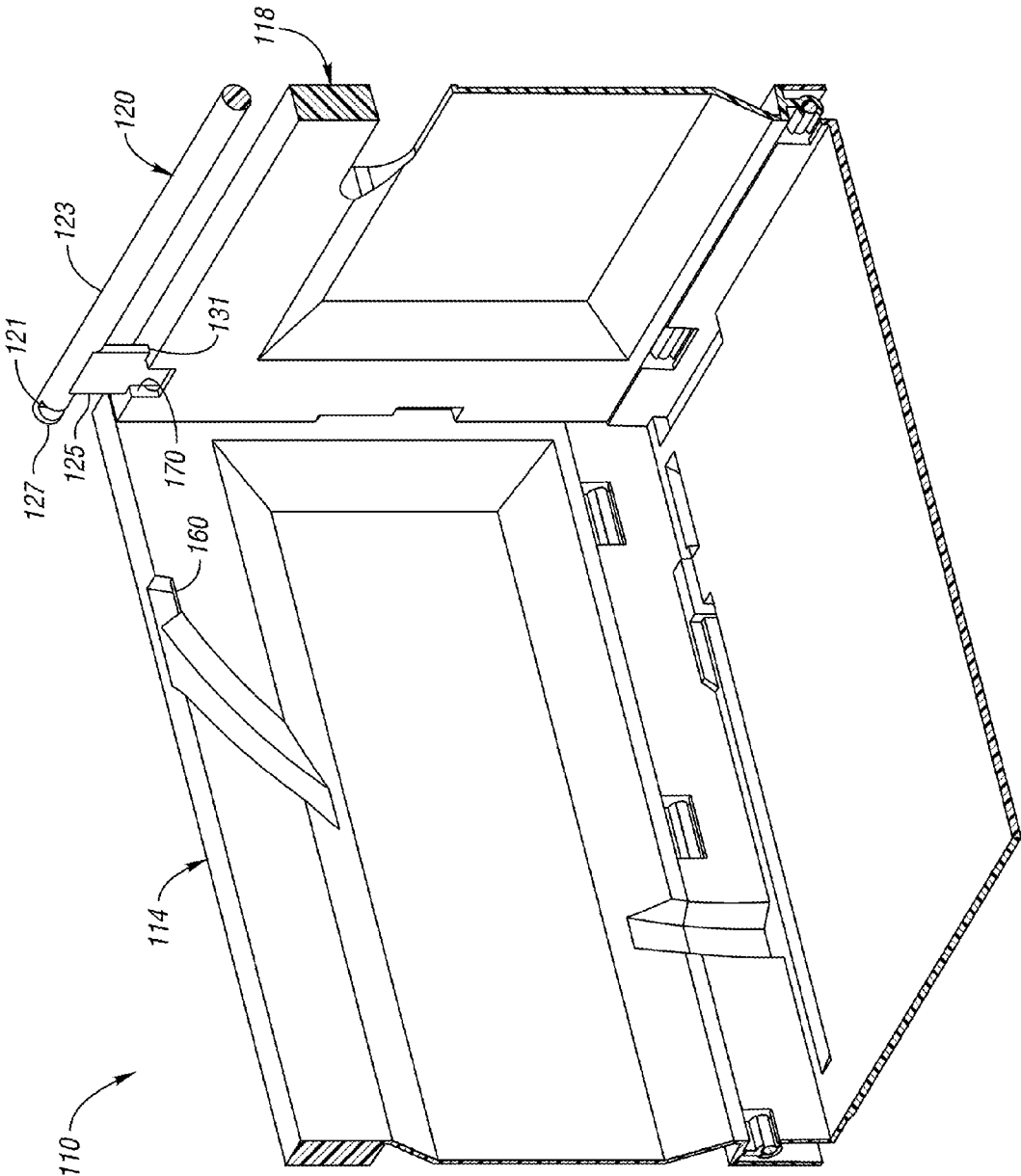

Fig. 12

Fig. 18

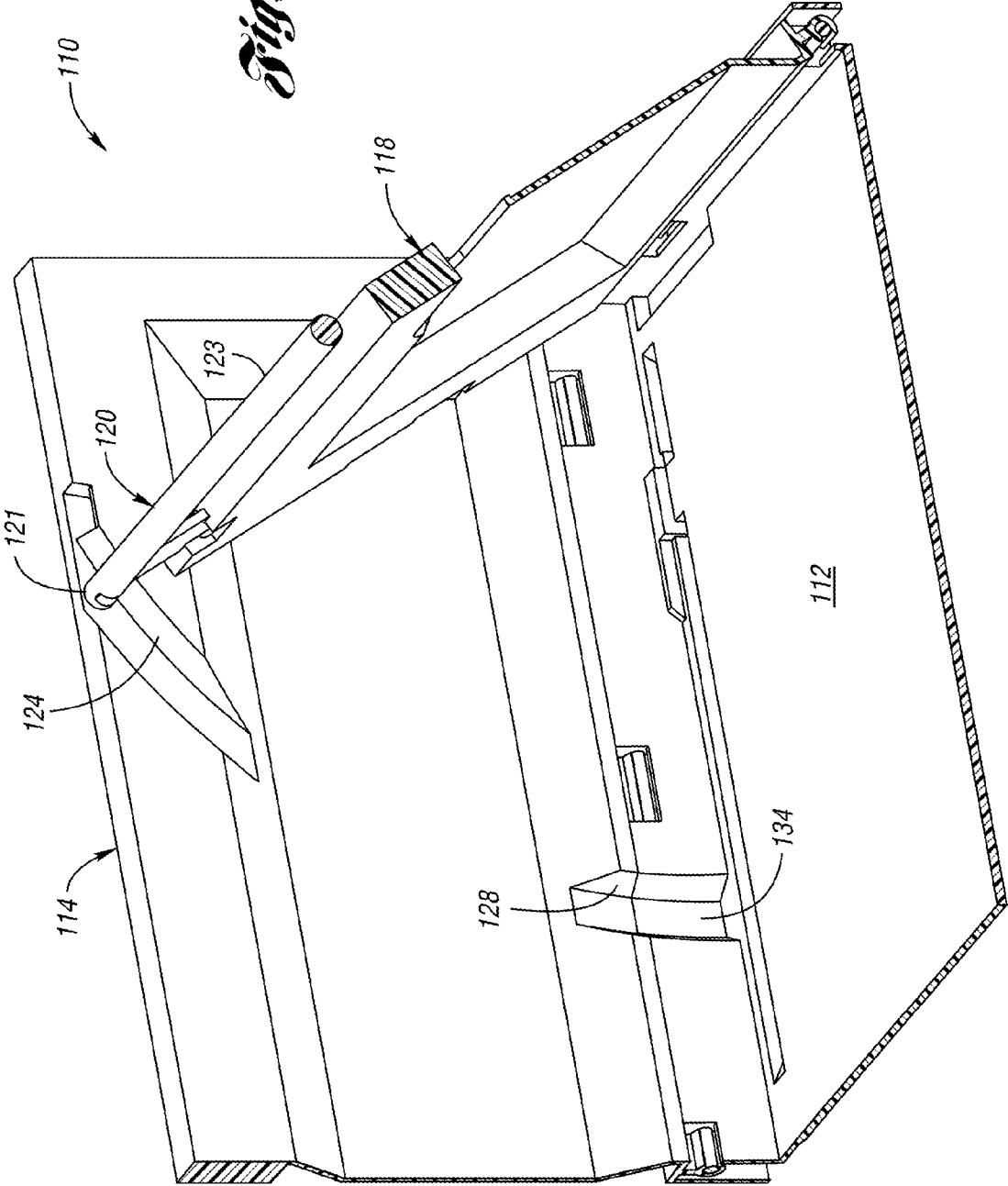
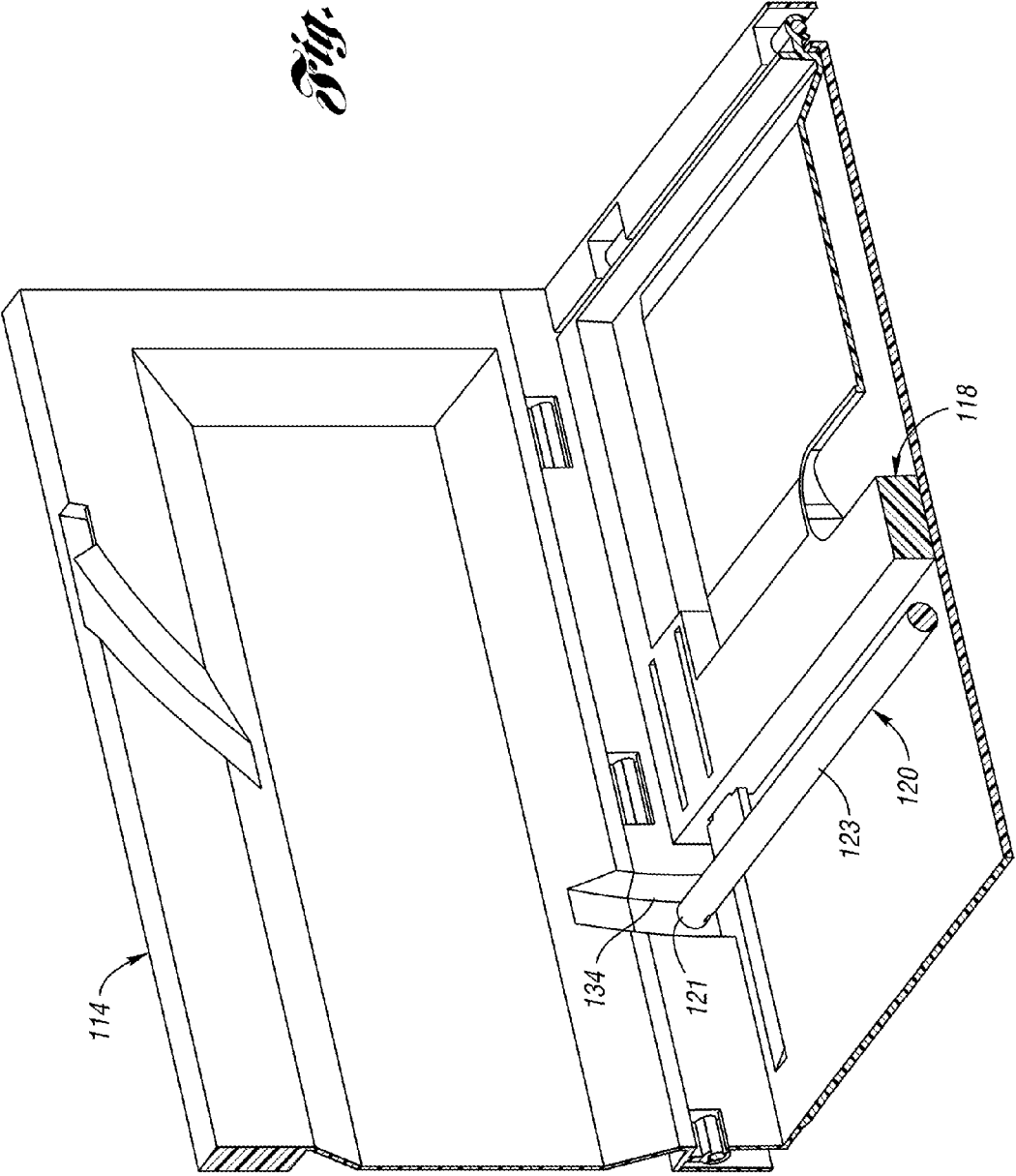

Fig. 19



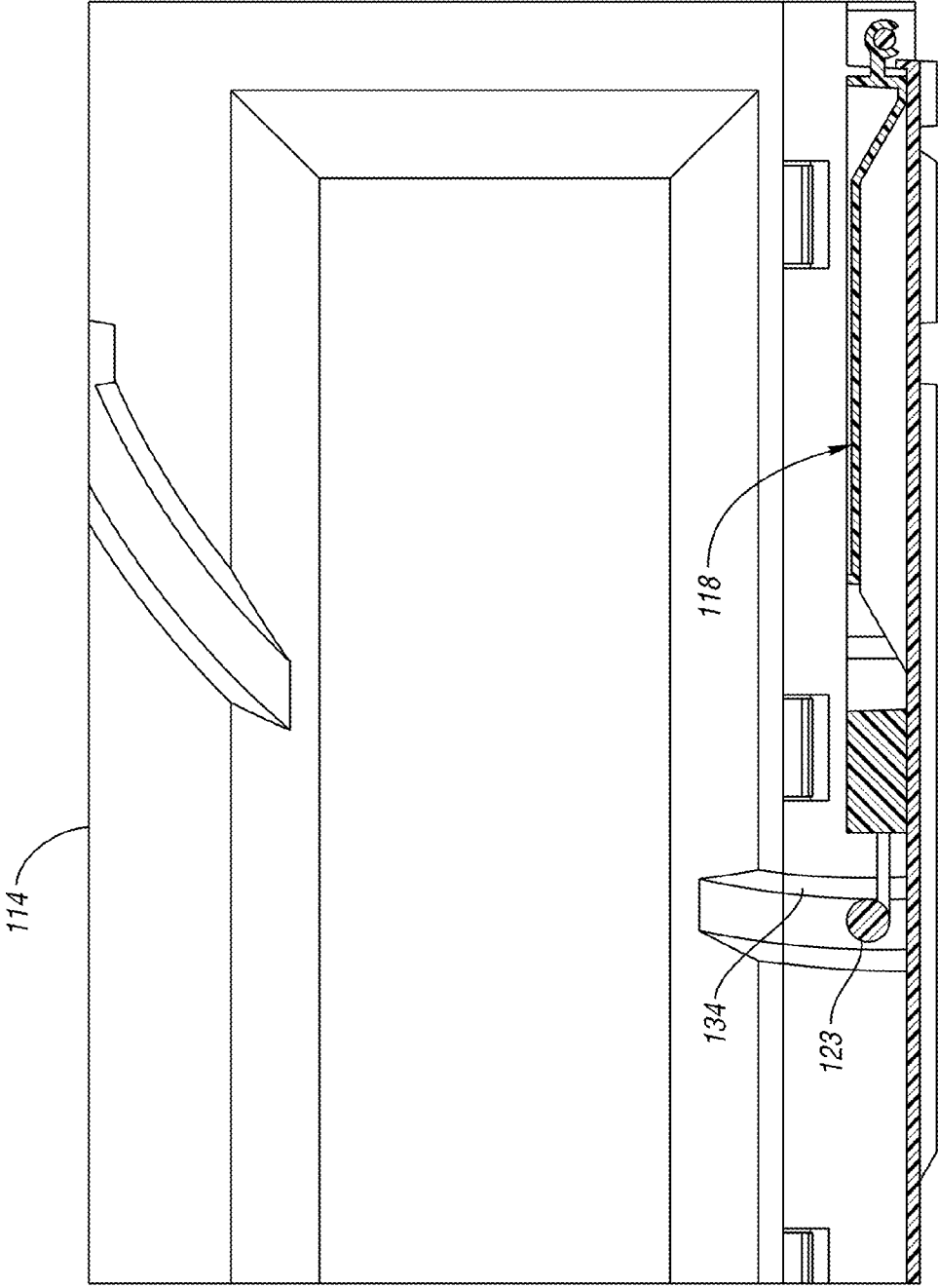

Fig. 20

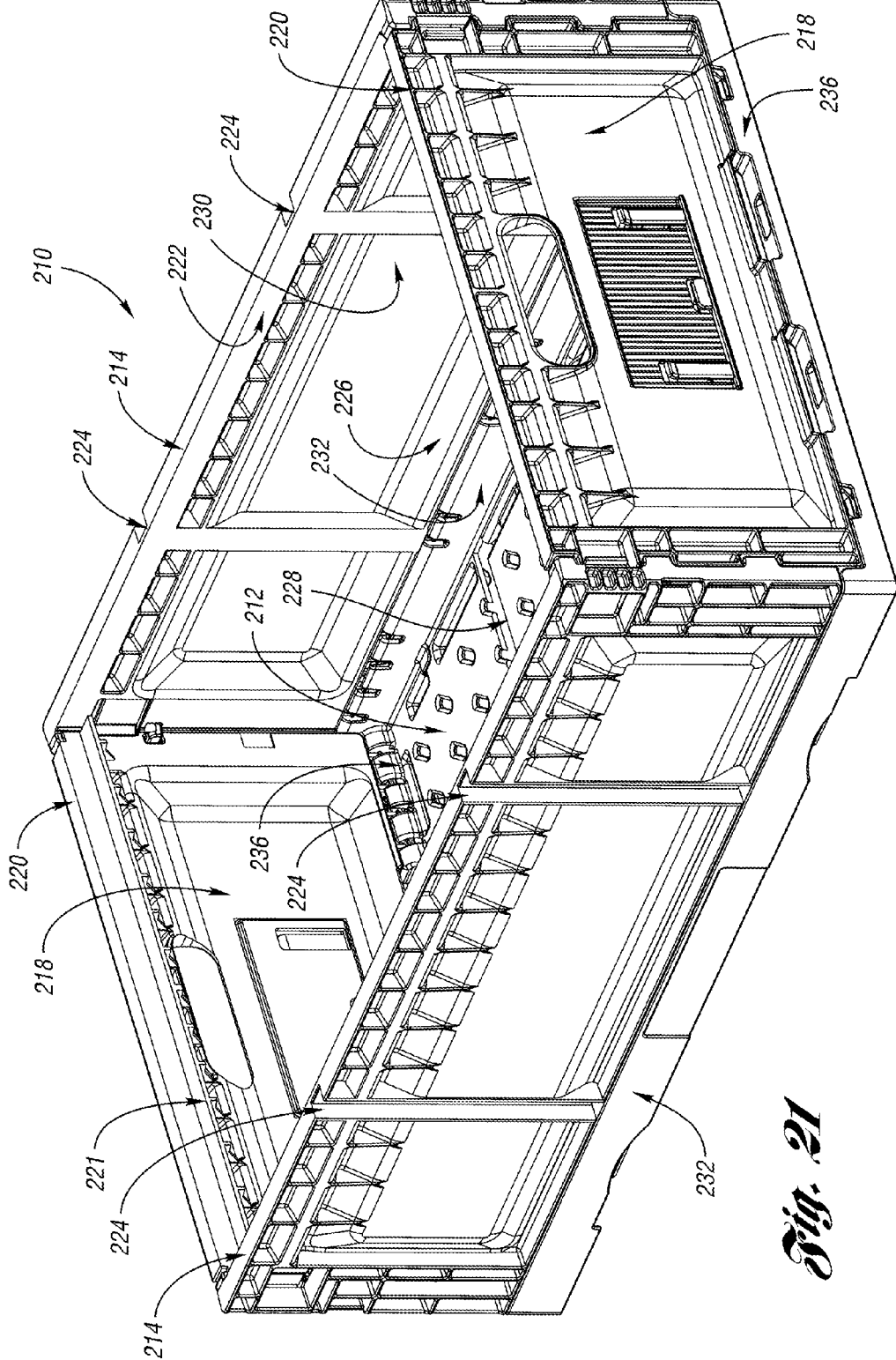

Fig. 21

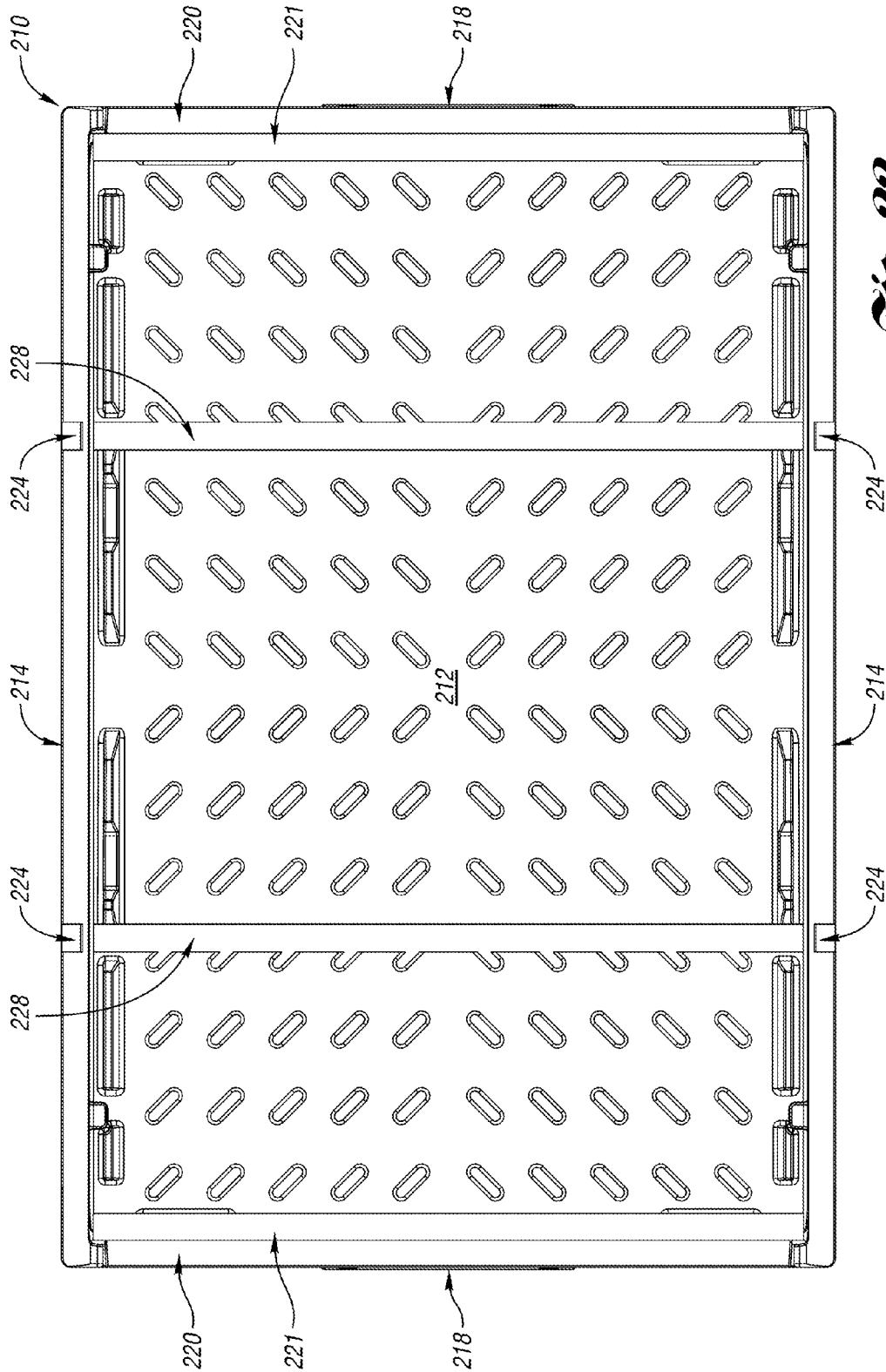

Fig. 22

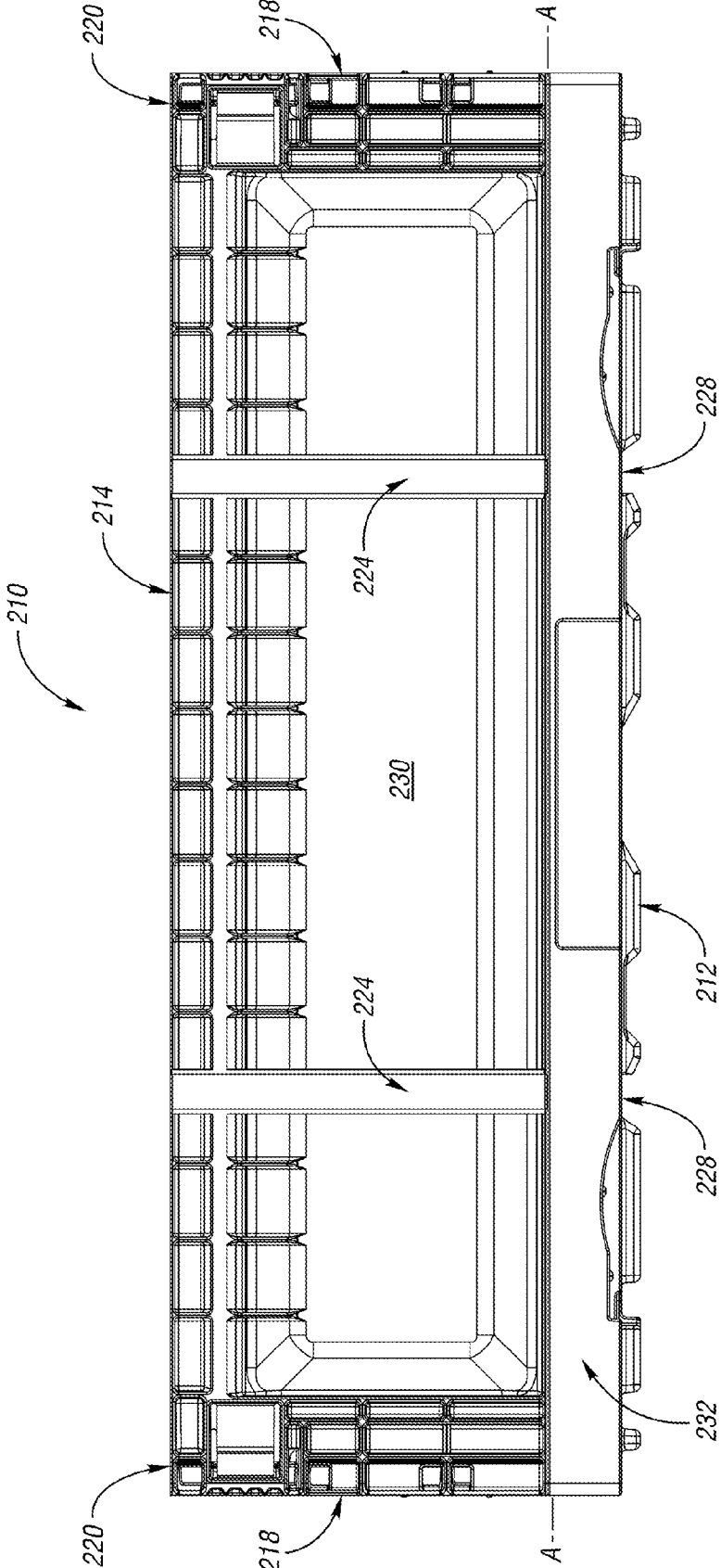

Fig. 23

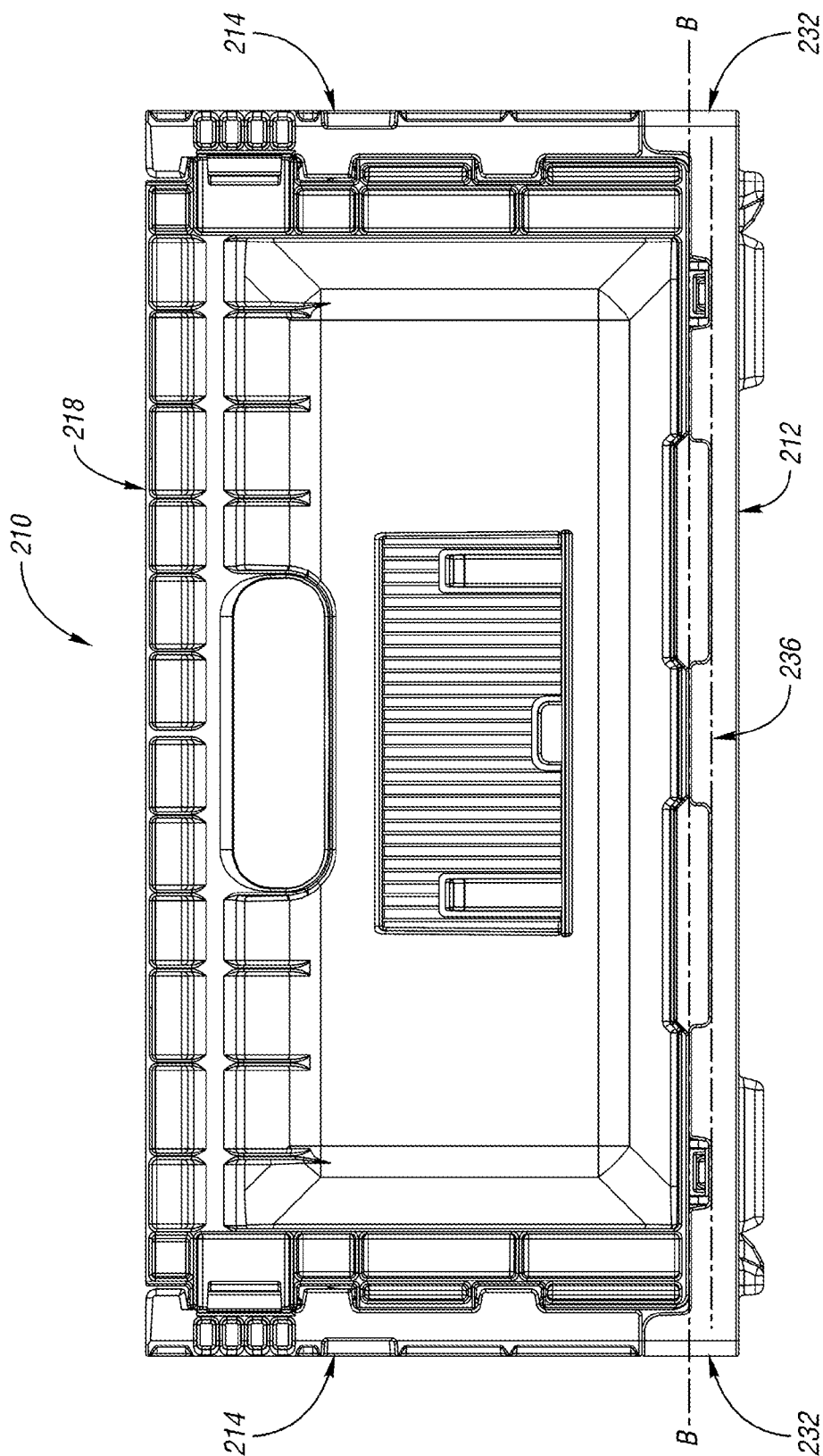

Fig. 24

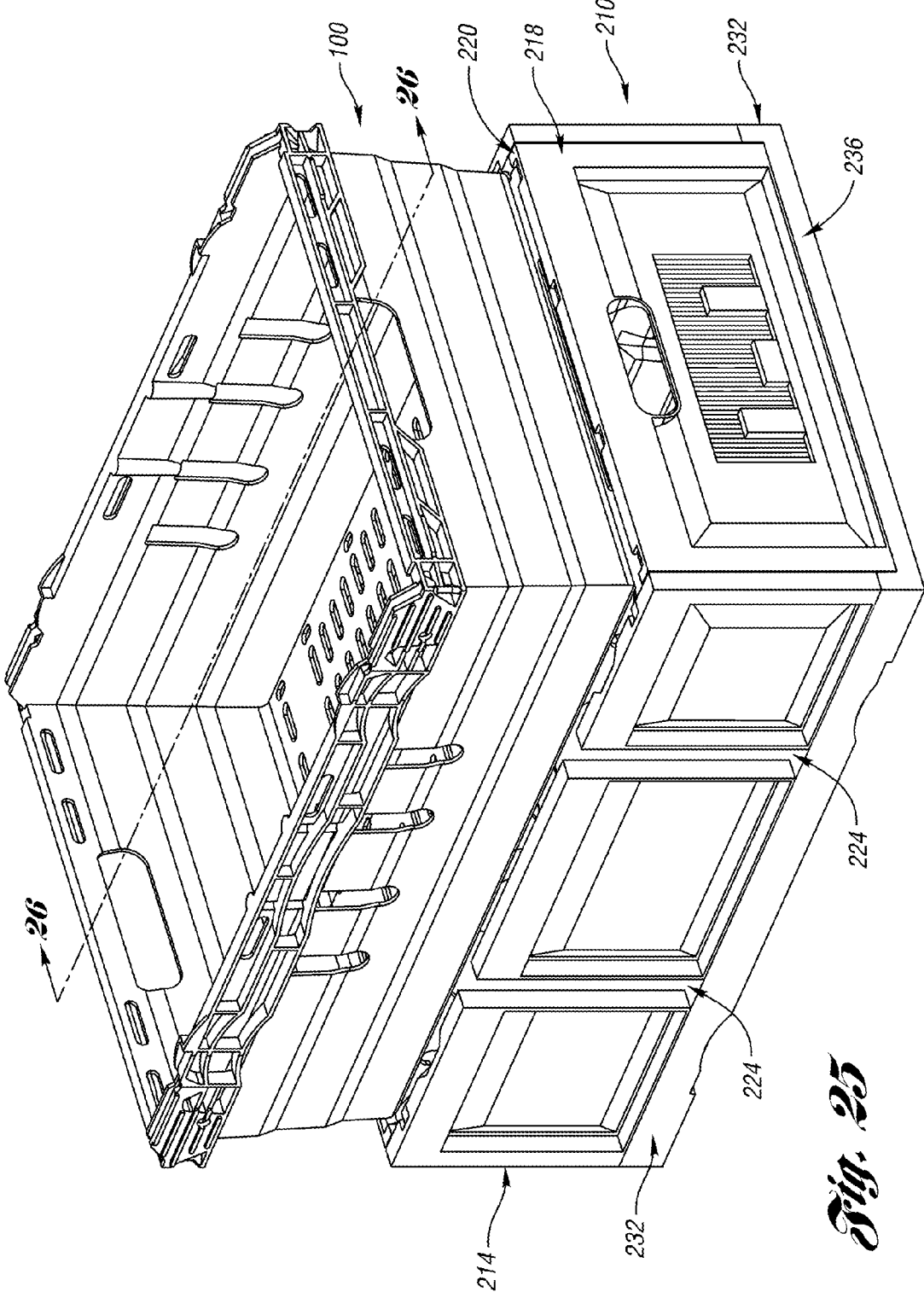

Fig. 25

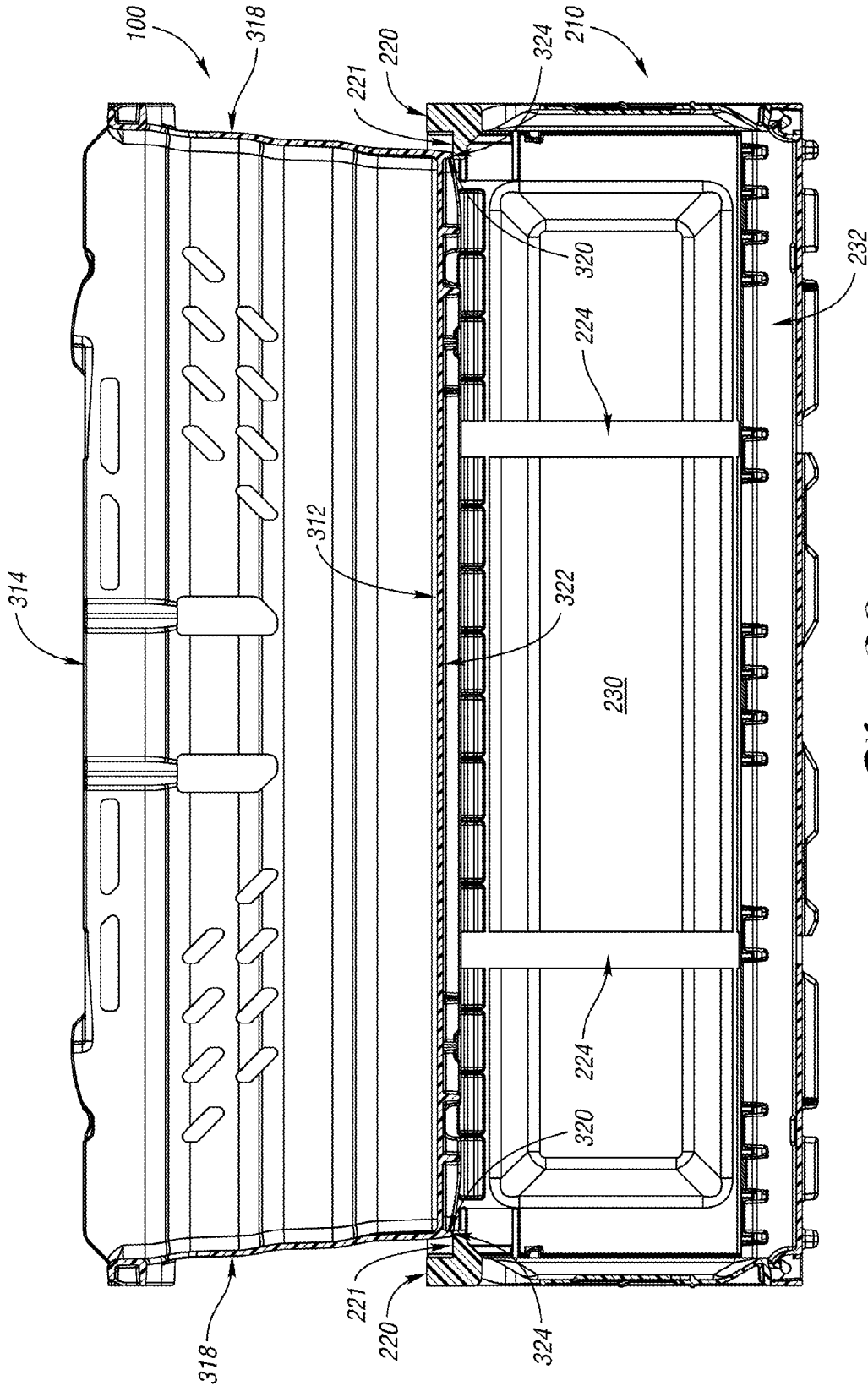

Fig. 26

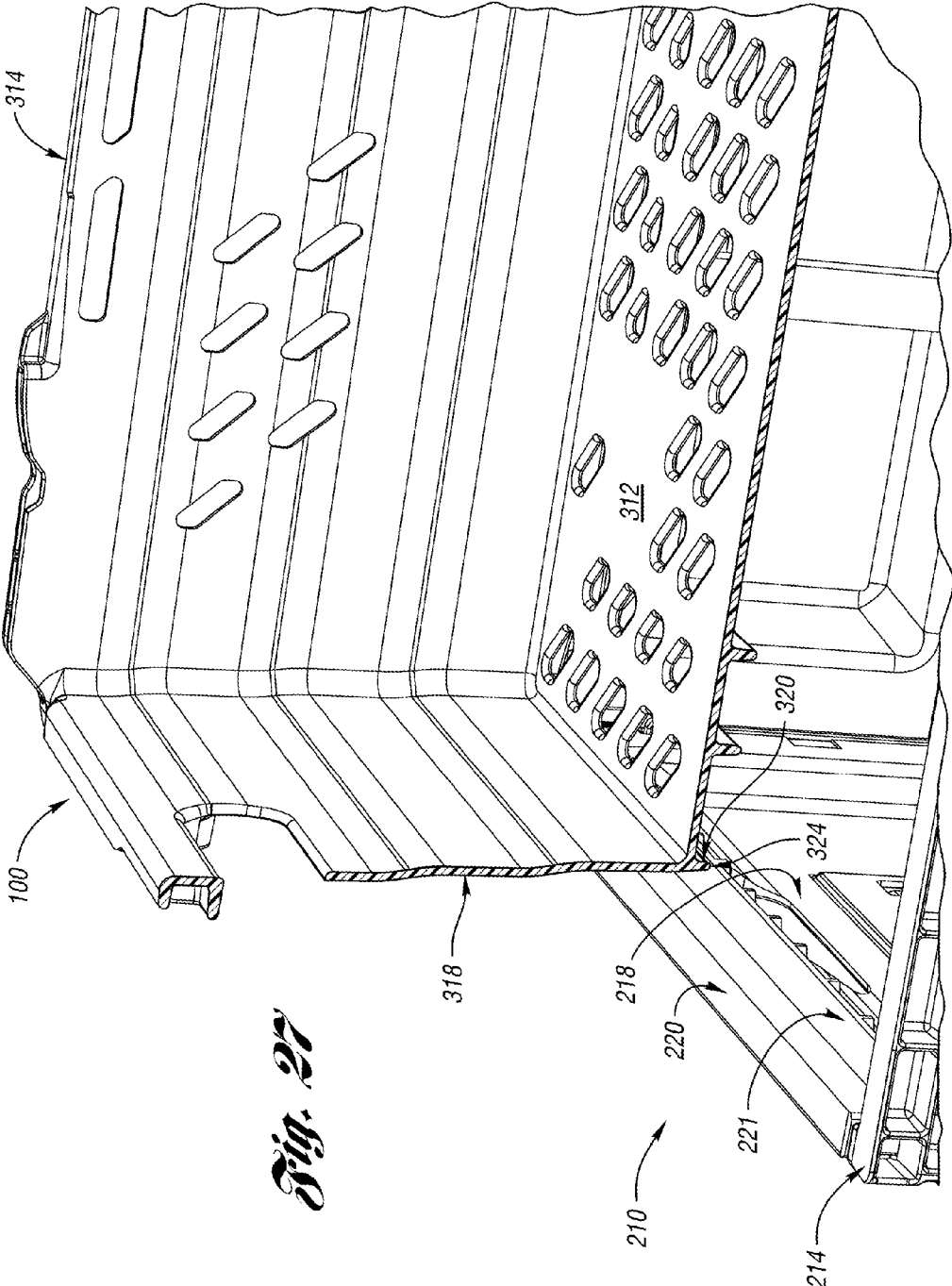

Fig. 27

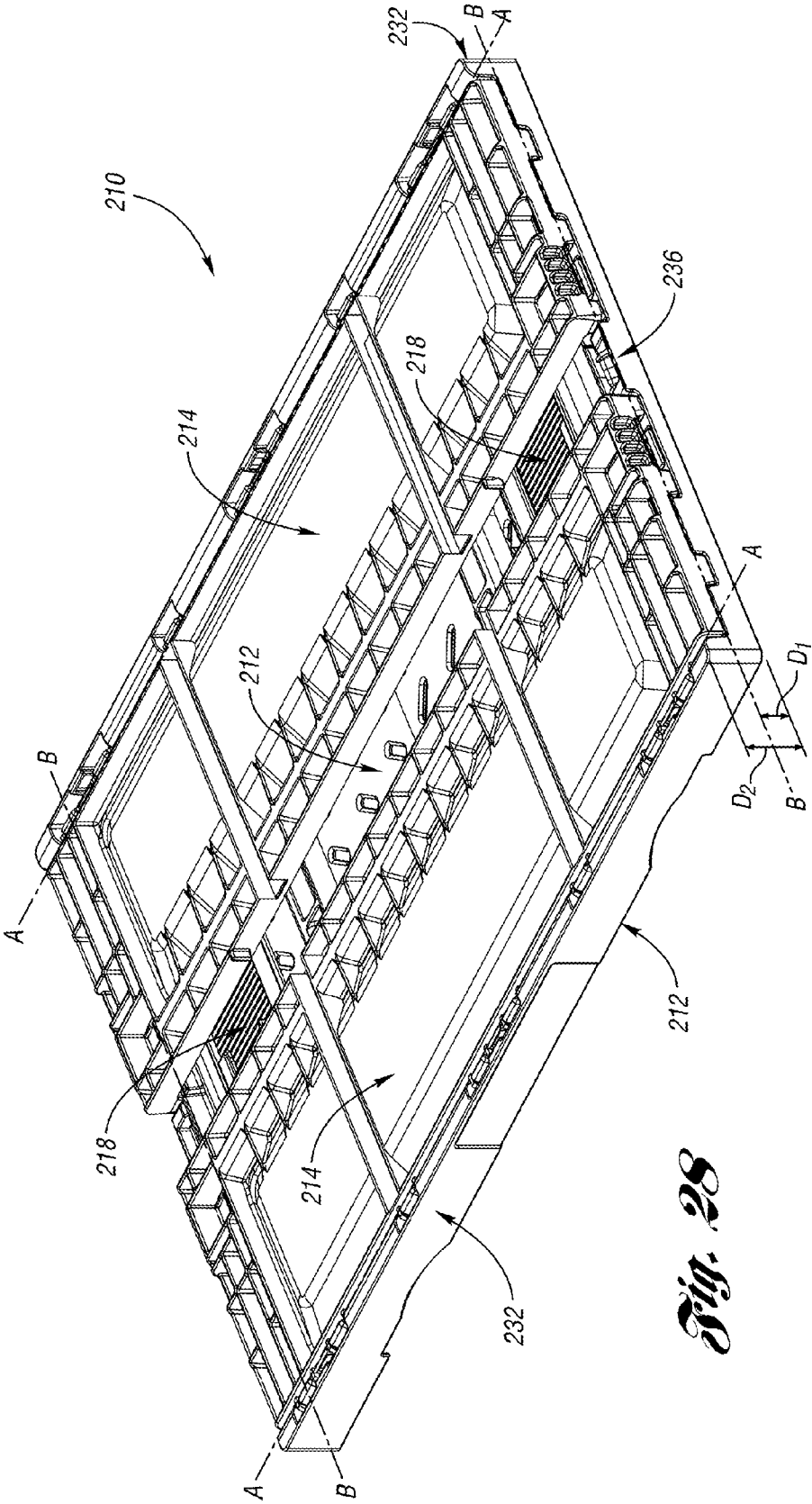
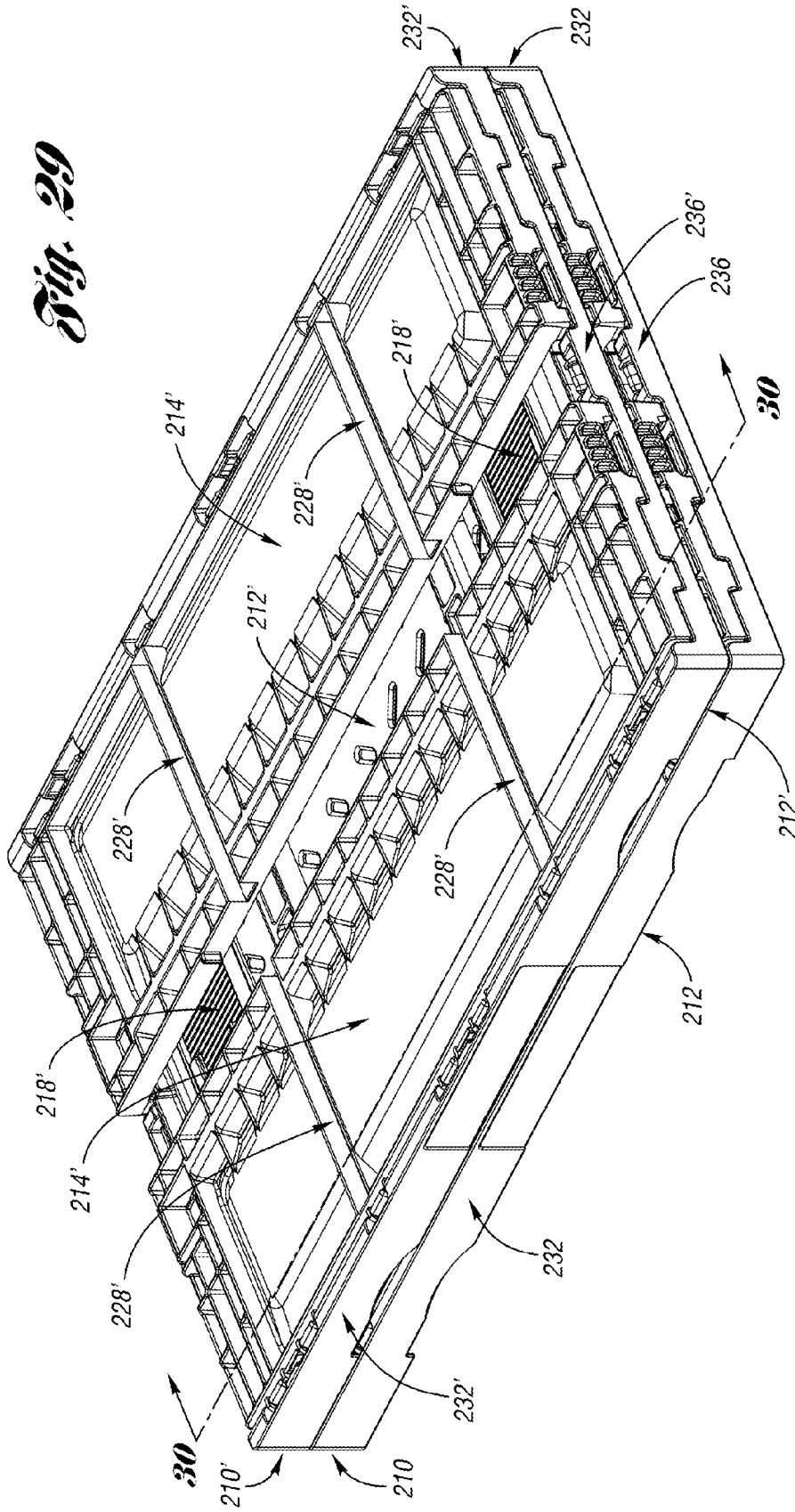

Fig. 28

Fig. 29



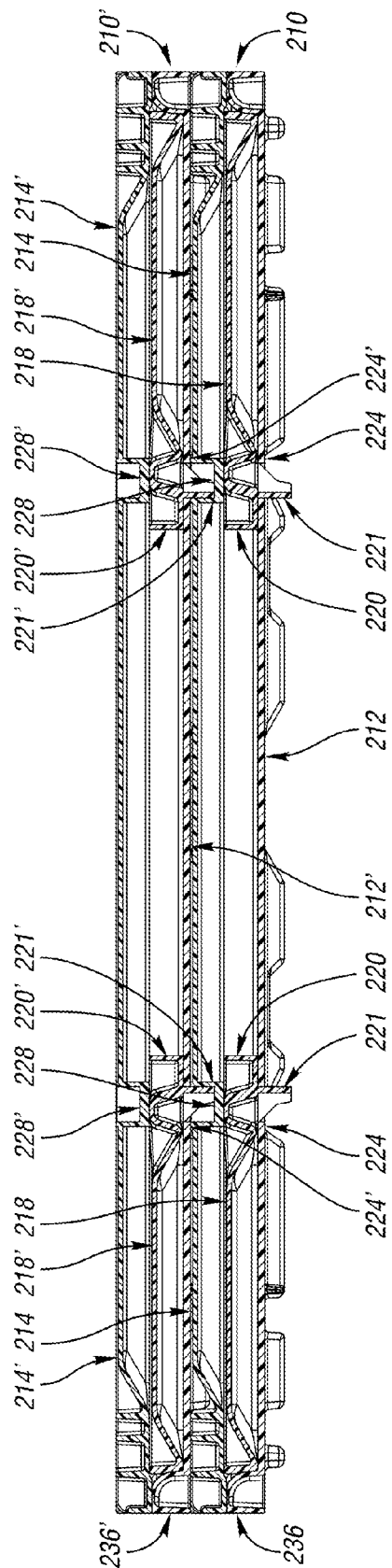

Fig. 30

CONTAINER

[0001] This application is a continuation of U.S. patent application Ser. No. 11/264,371, which was filed on Nov. 1, 2005.

BACKGROUND OF THE INVENTION

[0002] The present invention relates generally to collapsible crates and more particularly to a collapsible crate with support members for supporting another container thereon.

[0003] Collapsible crates are well known. Four walls each connected via a hinge to a base are selectively movable about the hinge between a use position, in which the wall is generally perpendicular to the base, and a collapsed position onto the base. Various mechanisms have been provided to connect adjacent walls at the corner to selectively lock the crate in the use position.

SUMMARY OF THE INVENTION

[0004] The present invention provides a collapsible container having a plurality of walls collapsible onto the base. At least one wall has a support mounted to an upper end portion thereof.

[0005] In one example embodiment, the support is pivotably mounted to an upper end portion of the at least one wall. The support is pivotable between a support position where it is partially supported on an adjacent wall and a retracted position. In the retracted position, the wall can be pivoted downward onto the base, with a portion of the support passing through a channel formed on the interior of the adjacent wall.

[0006] In another example, the support is integrally formed with the upper portion of the at least one wall.

[0007] The supports may be formed on short end walls of the container, such that the supports and end walls can be collapsed onto the base and the long side walls can be pivoted onto the end walls. In this manner, the supports are protected from damage during shipping of the containers in the collapsed position. The supports may also be formed on long side walls of the container, such that the supports and side walls can be collapsed onto the base and the short end walls can be pivoted onto the side walls.

BRIEF DESCRIPTION OF THE DRAWINGS

[0008] Other advantages of the present invention can be understood by reference to the following detailed description when considered in connection with the accompanying drawings wherein:

[0009] FIG. 1 is a perspective view of a container according to the present invention, with the walls in the upright position and the supports pivotable mounted in the support position.

[0010] FIG. 2 illustrates the container of FIG. 1 with a second container supported thereon.

[0011] FIG. 3 is an interior perspective view, partially broken away, of the container of FIG. 1.

[0012] FIG. 4 is a sectional view taken along lines 4-4 of FIG. 3.

[0013] FIG. 5 is a sectional view taken along lines 5-5 of FIG. 3.

[0014] FIG. 6 is a view similar to that of FIG. 3, with the support in the retracted position.

[0015] FIG. 7 illustrates the container of FIG. 6 with the wall being pivoted toward the collapsed position.

[0016] FIG. 8 illustrates the container of FIG. 6 with the wall in the collapsed position.

[0017] FIG. 9 is an enlarged sectional view take along line 9-9 of FIG. 6.

[0018] FIG. 10 illustrates the container of FIG. 8 with the side wall collapsed onto the end wall.

[0019] FIG. 10A is an exterior perspective view of the container of FIG. 1 showing a latch that could be used to connect adjacent walls.

[0020] FIG. 11 is a perspective view of a container according to a second embodiment of the present invention, with the walls in the upright position and the supports in the support position.

[0021] FIG. 12 illustrates the container of FIG. 11 with a second container supported thereon.

[0022] FIG. 13 is a perspective view of one of the supports of FIG. 11.

[0023] FIG. 14 is an interior perspective view, partially broken away, of the container of FIG. 11.

[0024] FIG. 15 is a sectional view taken along lines 15-15 of FIG. 14.

[0025] FIG. 16 is a view similar to that of FIG. 14, with the support in the vertical position.

[0026] FIG. 17 is a view similar to that of FIG. 16, with the support in the fully retracted position.

[0027] FIG. 18 illustrates the container of FIG. 17 with the wall being pivoted toward the collapsed position.

[0028] FIG. 19 illustrates the container of FIG. 17 with the wall in the collapsed position.

[0029] FIG. 20 is a side view of the sectioned container of FIG. 19.

[0030] FIG. 21 is a perspective view of a container according to a third embodiment of the present invention, with the walls in the upright position and the supports fixedly mounted.

[0031] FIG. 22 is a top view of an interior of the container of FIG. 21.

[0032] FIG. 23 is a side view of the container of FIG. 21.

[0033] FIG. 24 is an end view of the container of FIG. 21.

[0034] FIG. 25 illustrates the container of FIG. 21 with a second container supported thereon.

[0035] FIG. 26 is a sectional view taken along lines 26-26 of FIG. 23.

[0036] FIG. 27 illustrates the pair of containers of FIG. 25 including a cut-away view of the second container.

[0037] FIG. 28 is a perspective view of a container according to the third embodiment of the present invention, with the walls in the collapsed position and the supports fixedly mounted.

[0038] FIG. 29 illustrates the collapsed container of FIG. 28 with a second collapsed container supported thereon.

[0039] FIG. 30 is a sectional view taken along lines 30-30 of FIG. 29.

DETAILED DESCRIPTION OF THE PREFERRED EMBODIMENTS

[0040] Referring to FIG. 1, a container 10 includes a base 12 having upstanding side walls 14 (or long walls) and upstanding end walls 18 (or short walls). The side walls 14 and end walls 18 are pivotably connected along long and short edges of the base 12, respectively. The side walls 14 and end walls 18 are movable between the upright position shown and a collapsed position on the base 12.

[0041] Each end wall 18 has a support 20 (or flap) pivotably mounted to an upper portion thereof. The supports 20 are shown in FIG. 1 pivoted to a support position generally perpendicular to the end walls 18 and projecting into the interior of the container 10. In the support position, laterally-extending tabs 21 are supported on the side walls 14.

[0042] The interiors of the side walls 14 each include an upper frame portion 22 protruding into the container 10. A pair of curved channels 24 is formed through each upper frame portion 22. The interiors of the side walls 14 each further include a lower frame portion 26 having a pair of channels 28 formed therethrough. A recess 30 is defined between the upper frame portion 22 and the lower frame portion 26. The base 12 includes a pair of side upstanding portions 32 to which the side walls 14 are pivotably attached. Each side upstanding portion 32 includes a pair of channels 34 formed on an interior thereof. The channels 24, 28 and 34 are aligned with one another in a manner that will be explained below. The base 12 further includes a pair of end upstanding portions 36 to which the end walls 18 are pivotably attached.

[0043] Referring to FIG. 2, with the supports 20 in the support position, another container 100 can be supported on the supports 20 of the container 10.

[0044] FIG. 3 is an interior perspective view, partially broken away, of the container 10 of FIG. 1. The support 20 includes a stop member 38, such as an elongated rib projecting outwardly from a bottom edge of the support 20. The support 20 further includes an interlocking feature 40, such as an elongated rib extending upwardly from an upper edge of the support 20. As shown, the tab 21 of the support 20 is received in a recess 44 at the upper edge of the side wall 14 when the support 20 is in the support position. As can also be seen in FIG. 3, the tab 21 does not align with the channels 24, 28 or 34 when the support 20 is in the support position. The end wall 18 includes a handle 42 formed therein.

[0045] FIG. 4 is a sectional view taken along lines 4-4 of FIG. 3. The end wall 18 may be pivotably connected to the base 12 via a hinge including a hinge member 48 integral with the end wall 18 and a hinge pin 50 integral with the base 12.

[0046] FIG. 5 is a sectional view taken along lines 5-5 of FIG. 3. The support 20 is pivotably connected to an upper portion of the end wall 18 via a hinge including a hinge member 54 integrally molded with the support 20 and a hinge pin 56 integrally molded with the end wall 18.

[0047] FIG. 6 is a view similar to that of FIG. 3, with the support 20 in the retracted position (i.e. retracted from the interior of the container 10). In the retracted position, the support 20 is pivoted upwardly until the stop member 38 abuts the upper edge of the end wall 18, thereby preventing further movement. In the retracted position, the support 20 does not project into the interior of the container 10 and is generally parallel to the end wall 18, extending upwardly from the upper edge of the end wall 18. As can be seen in FIG. 6, the tab 21 includes a recess 58 on its underside that receives a projection 60 adjacent the recess 44 in the side wall 14 so that the tab 21 interlocks with the side wall 14.

[0048] FIG. 7 illustrates the container 10 of FIG. 6 with the end wall 18 being pivoted toward the collapsed position. With the support 20 in the retracted (upright) position, as the end wall 18 is pivoted downwardly, the tab 21 of the support 20 passes through the channel 24 in the upper frame portion 22, through the recess 30, through the channel 28 in the lower frame portion 26 and through the channel 34 in the side upstanding portion 32 of the base 12. FIG. 8 illustrates the container 10 of FIG. 6 with the end wall 18 in the collapsed position. The tab 21 of the support 20 is received in the channel 34 in the side upstanding portion 32 of the base 12. The end wall 18 and support 20 lie flush with the base 12. The other end wall 18 (not shown) collapses similarly and the end walls 18 do not overlap each other. The side walls 14 can then be collapsed onto the end walls 18. The supports 20 are flush with the end walls 18 and protected by the side walls 14.

[0049] FIG. 9 is an enlarged sectional view take along line 9-9 of FIG. 6. As shown, the hinge member 54 of the support 20 includes a projection 64 that interacts with a projection 66 on the end wall 18 to form a detent that retains the support 20 in the retracted, upright position. The hinge member 54 extends into a cavity 70 formed at the upper inner edge of the end wall 18. The projection 66 is formed on a lower surface of the cavity 70. The stop member 38 of the support 20 abuts the upper edge of the end wall 18 to prevent further rotation.

[0050] FIG. 10 illustrates the container 10 of FIG. 8 with the side wall 14 collapsed onto the end wall 18. FIG. 10A is an exterior perspective view of the container 10 showing a latch 72 that could be used to connect adjacent walls 14, 18. Although for clarity they have not been illustrated in the other Figures herein, it is known that collapsible containers, such as the collapsible container 10 (and the collapsible container 110, below), have latches connecting adjacent walls in the upright position. The latches can be manual latches 72 as shown in FIG. 10A, or knock-down latches. The latch 72, or any other sort of latch, could also be used in the container 110 described below.

[0051] FIG. 11 illustrates a container 110 according to a second embodiment of the present invention. The container 110 includes a base 112 having upstanding side walls 114 (or long walls) and upstanding end walls 118 (or short walls). The side walls 114 and end walls 118 are pivotably connected along long and short edges of the base 112, respec-

tively. The side walls 114 and end walls 118 are movable between the upright position shown and a collapsed position on the base 112.

[0052] Each end wall 118 has a support 20 pivotably mounted to an upper portion thereof. The supports 120 are shown in FIG. 11 pivoted to a support position generally perpendicular to the end walls 118 and projecting into the interior of the container 110. Each support 120 includes an elongated rail 123 and a pair of arms 125 extending perpendicularly from the rail 123. In the support position, laterally-extending ends 121 of the rail 123 are supported on the side walls 114.

[0053] The interiors of the side walls 114 each include an upper frame portion 122 protruding into the container 110. A pair of curved channels 124 is formed through each upper frame portion 122. The interiors of the side walls 114 each further include a lower frame portion 126 having a pair of channels 128 formed therethrough. A recess 130 is defined between the upper frame portion 122 and the lower frame portion 126. The base 112 includes a pair of side upstanding portions 132 to which the side walls 114 are pivotably attached. Each side upstanding portion 132 includes a pair of channels 134 formed on an interior thereof. The channels 124, 128 and 134 are aligned with one another. The base 112 further includes a pair of end upstanding portions 136 to which the end walls 118 are pivotably attached.

[0054] FIG. 12 illustrates the container of FIG. 11 with the second container 100 supported thereon.

[0055] FIG. 13 is a perspective view of one of the supports 120 of FIG. 11. Each support 120 includes the elongated rail 123 and the pair of arms 125 extending perpendicularly from the rail 123. A slot 127 is formed on the underside of the rail 123 adjacent each end 121. Each of the arms 125 includes an integral pivot pin 129 at an end of the arm 125 opposite the rail 123. Each of the arms 125 includes a shoulder 131 spaced away from the rail 123.

[0056] FIG. 14 is an interior perspective view, partially broken away, of the container 110 of FIG. 11. As shown, the end 121 of the support 120 is received in a recess 144 at the upper edge of the side wall 114 adjacent the channel 124 when the support 120 is in the support position. The end 121 of the rail 123 does not align with the channels 124, 128 or 134 when the support 120 is in the support position. The end wall 118 includes a handle 142 formed therein.

[0057] FIG. 15 is a sectional view taken along lines 15-15 of FIG. 14. The end wall 118 may be pivotably connected to the base 112 via a hinge including a hinge member 148 integral with the end wall 118 and a hinge pin 150 integral with the base 112.

[0058] FIG. 16 is a view similar to that of FIG. 14, with the support 120 in the vertical position. In FIG. 16, the support 120 has been pivoted about pivot pin 129 from the support position shown in FIG. 16 to the vertical position. The rail 123 is spaced above an upper edge of the end wall 118, with the arm 125 fully extended. The pivot pin 129 is pivotably and slidably connected to a channel 170 in the end wall 118. An upwardly projecting rib 160 is adjacent the recess 144 in the upper edge of the side wall 114 for interlocking with the slot 127 in the end 121 of the rail 123.

[0059] FIG. 17 is a view similar to that of FIG. 16, with the support 120 in the fully retracted position. The arm 125

is inserted into the channel 170 in the end wall 118 until the shoulder 131 abuts the upper edge of the end wall 118, leaving the rail 123 and the end 121 of the rail 123 a known distance from the upper edge of the end wall 118.

[0060] In this position, the end wall 118 can be pivoted to the collapsed position as shown in FIG. 18. As the end wall 118 is being pivoted toward the collapsed position, the end 121 of the rail 123 passes through the channel 124, the recess 130, the channel 128 and the channel 134 until the end wall 118 lies on the base 112, as shown in FIG. 19. FIG. 20 is an enlarged sectional view taken along line 20-20 of FIG. 19.

[0061] Referring to FIG. 21, a container 210, according to a third embodiment, includes a base 212 having upstanding side walls 214 (or long walls) and upstanding end walls 218 (or short walls). The side walls 214 and end walls 218 are pivotably connected along long and short edges of the base 212, respectively. The side walls 214 and end walls 218 are movable between the upright position as shown and a collapsed position as shown in FIG. 28.

[0062] Each end wall 218 has a support 220 integrally molded to an upper portion thereof. The supports 220 are fixed in a support position generally perpendicular to the end walls 218 and include support tabs 221, projecting into the interior of the container 210. The support tabs 221 extend substantially horizontally inward from the end walls 218.

[0063] The interiors of the side walls 214 each include an upper frame portion 222 and a lower frame portion 226 protruding into the container 210. A pair of vertical channels 224 is formed on an outer surface of each of the pair of side walls 214. A recess 230 is defined between the upper frame portion 222 and the lower frame portion 226.

[0064] The base 212 includes a pair of side upstanding portions 232 to which the side walls 214 are pivotably attached. A pair of support channels 228 is formed as a pair of openings through the base 212. The base 212 further includes a pair of end upstanding portions 236 to which the end walls 218 are pivotably attached.

[0065] FIG. 22 is a top view of an interior of the container 210, which includes the base 212 having upstanding side walls 214 (or long walls) and upstanding end walls 218 (or short walls) pivotably connected along long and short edges of the base 212 respectively. The side walls 214 and the end walls 218, which are moveable between an upright position and a collapsed position (FIG. 28), are shown the upright position.

[0066] Supports 220 are integrally molded along an upper edge of each of the pair of end walls 218. Each of the supports 220 includes a support tab 221 that extends substantially horizontally inward from each of the end walls 218, such that each support tab 221 is substantially perpendicular to each respective end wall 218. In the upright position, the support tabs 221 provide structure to support a second container 310 (FIG. 25) stacked thereon. It should be appreciated, however, that each of the supports 220 including the support tabs 221 could also be formed separate from the end walls 218 and subsequently mounted to the end walls 218.

[0067] A pair of support channels 228, which are formed within the base 212, extend from one of the side walls 214 to the other of the side walls 214. The support channels 228

provide clearance for the support tabs **221**, when the container **210** is in the collapsed position as shown in FIG. **28**.

[0068] Referring to FIG. **23**, the side wall **214** is pivotable about an axis A-A from an upright position as shown to a collapsed position as shown in FIG. **28**. The axis A-A is located at an intersection formed by the side upstanding portion **232** of the base **212** and the side wall **214**.

[0069] Referring to FIG. **24**, the end wall **218** is pivotable about an axis B-B from an upright position as shown to a collapsed position as shown in FIG. **28**. The axis B-B is located at an intersection formed by the end upstanding portion **236** of the base **212** and the end wall **218**.

[0070] FIG. **25** illustrates the container **210** of FIG. **21** with the second container **100** supported thereon.

[0071] FIG. **26** is a sectional view taken along lines **26-26** of FIG. **25**. The second container **100** includes a bottom **312**, side walls **314** and end walls **318**. A support lip **320** protrudes from an underside **322** of the bottom **312** of the second container **100** and extends around a periphery of the underside **322**.

[0072] As further illustrated in FIG. **27**, the support lip **320** includes a support surface **324** that rests on the support tabs **221** of the container **210** to support the second container **310** thereon.

[0073] FIG. **28** illustrates the container **210** of FIG. **21** in the collapsed position. End walls **218** are pivoted inward about axes A-A and collapsed onto the base **212**. Side walls **214** are pivoted inward about axes B-B and collapsed substantially onto the end walls **218**. In the collapsed position, the end walls **218** define a first plane substantially parallel to a base plane defined by the base **212**. Further, in the collapsed position, the side walls **214** define a second plane substantially parallel to both the first plane and the base plane. The first plane being a first distance D_1 away from the base plane and the second plane being a second distance D_2 , greater than the first distance D_1 , away from the base plane.

[0074] FIG. **29** illustrates the collapsed container **210** of FIG. **28** with a second collapsed container **210'** stacked thereon.

[0075] FIG. **30** is a sectional view taken along lines **30-30** of FIG. **29**. The collapsed container **210** has the second collapsed container **210'** stacked thereon. Each collapsed container **210**, **210'** includes a base **212**, **212'** having support channels **224**, **224'** formed therethrough. End walls **218**, **218'** including supports **220**, **220'** and support tabs **221**, **221'** are collapsed onto each base **212**, **212'**. In the collapsed position, the support tabs **221**, **221'** extend at least partially through the support channels **224**, **224'** formed in the base **212**, **212'**.

[0076] Side walls **214**, **214'** are collapsed substantially onto the collapsed end walls **218**, **218'**. The collapsed side walls **214**, **214'** include channels **228**, **228'** formed therein.

[0077] In the collapsed position, the support tabs **221'** of the second collapsed container **210'** extend at least partially through the support channels **224'** formed in the base **212'** of the second collapsed container **210'**. Further, in the stacked configuration, the support tabs **221'** of the second container **210'** extend through the support channels **224'** and are at

least partially received within the channels **228** formed in the collapsed side walls **214** of the lower collapsed container **210**.

[0078] While embodiments of the invention have been illustrated and described, it is not intended that these embodiments illustrate and describe all possible forms of the invention. Rather, the words used in the specification are words of description rather than limitation, and it is understood that various changes may be made without departing from the spirit and scope of the invention. For example, in any of the occurrences above, the hinge members and hinge pins could be reversed and formed on opposite parts.

What is claimed is:

1. A container comprising:

a base having opposed long edges and opposed short edges;

a first wall pivotably mounted to one of the edges of the base, wherein the first wall is pivotable between an upright position and a collapsed position; and

a support extending from the first wall, the support including a support structure positioned inward of the first wall.

2. The container of claim 1, wherein the support is pivotable about an axis generally parallel to the base, the support pivotable between a support position and a retracted position.

3. The container of claim 2, further including a hinge pivotably connecting the support to the first wall.

4. The container of claim 2, wherein the support includes a locating feature projecting upwardly from the support when the support is in the support position.

5. The container of claim 2, wherein the support is pivotably and slidably mounted to the first wall.

6. The container of claim 2, wherein the support is a flap pivotable between the retracted position generally parallel to the first wall and the support position generally transverse to the first wall.

7. The container of claim 2, further including an adjacent wall adjacent the first wall, the support supported by the first wall and the adjacent wall in the support position.

8. The container of claim 7, wherein the support is a flap having a lower end pivotably attached to an upper portion of the first wall, wherein the support is pivotable between the retracted position generally parallel to the first wall and the support position generally transverse to the first wall.

9. The container of claim 8, wherein the first wall and the support are collapsible onto the base when the support is in the retracted position.

10. The container of claim 9, wherein the support includes a laterally-extending tab, the tab contacting the adjacent wall to support the support in the support position.

11. The container of claim 10, wherein the adjacent wall includes a channel on an interior surface thereof, the tab passing through the channel as the first wall and the support are pivoted relative to the base to a collapsed position on the base.

12. The container of claim 11, wherein the channel is an upper channel through an upper frame portion, the interior surface of the adjacent wall further including a lower channel through a lower frame portion and a recess between the upper frame portion and the lower frame portion, the tab passing through the upper channel, the recess and the lower

channel as the first wall and the support are pivoted relative to the base to a collapsed position on the base.

13. The container of claim 5, wherein the support includes a stop member contacting the first wall and limiting pivoting motion of the support relative to the first wall when the support is in the retracted position.

14. The container of claim 5, wherein the support extends upward from an upper edge of the first wall when the support is in the retracted position.

15. The container of claim 1, wherein the support is formed integrally with an upper end portion of the first wall.

16. The container of claim 15, wherein the support structure extends inward from the first wall.

17. The container of claim 16, wherein the support structure is located a distance below an upper edge of the upper end portion of the first wall.

18. The container of claim 17, wherein the support structure is substantially parallel to the base when the first wall is in the upright position.

19. The container of claim 18, wherein base further includes at least one support channel formed therein for receiving at least a portion of the support structure when the first wall is in the collapsed position.

20. The container of claim 19, wherein the second wall of the container includes at least one channel formed therein for receiving at least a portion of a support structure of a second container in a collapsed position stacked thereon.

21. A container comprising:

a base;

a first wall mounted to the base and movable between an upright position and a collapsed position;

a second wall adjacent the first wall and movable between an upright position and a collapsed position on top of the first wall; and

a flap mounted to an upper end portion of the first wall.

22. The container of claim 21, wherein the flap is moveable between a first position supported on the second wall and a second position extending upwardly from an upper edge of the first wall.

23. The container of claim 22, wherein the flap and the first wall are movable to the collapsed position when the flap is in the second position.

24. The container of claim 23, wherein the flap is generally parallel to the first wall when the flap is in the second position.

25. The container of claim 21, wherein the flap is formed integrally with an upper edge of the first wall.

26. The container of claim 21, wherein the base further includes at least one support channel formed therein for receiving at least a portion of the support structure when the first wall is in the collapsed position.

27. The container of claim 26, wherein the second wall of the container includes at least one channel formed therein for receiving at least a portion of a support structure of a second container in a collapsed position stacked thereon.

28. A container comprising:

a base;

a first wall mounted to the base and movable between an upright position and a collapsed position;

a second wall adjacent the first wall and movable between an upright position and a collapsed position, the second wall including a channel on a surface thereof, and

a support mounted to an upper end portion of the first wall and including a laterally-extending portion.

29. The container of claim 28, wherein channel is formed in an interior surface and the support is movable between a first position where the laterally-extending portion is supported on the second wall and a second position where the laterally-extending portion of the flap can pass through the channel of the second wall as the first wall is pivoted to the collapsed position.

30. The container of claim 29, wherein the support is slidable and pivotable relative to first wall.

31. The container of claim 30, wherein the support is at least partially retractable into the first wall.

32. The container of claim 30, wherein the support is at least partially retractable into the first wall.

33. The container of claim 28, wherein the support is fixedly mounted to the first wall.

34. The container of claim 33, wherein the laterally-extending portion is located a distance below an upper edge of the upper end portion of the first wall.

35. The container of claim 34, wherein the laterally-extending portion is substantially parallel to the base when the first wall is in the upright position.

36. The container of claim 35, wherein the base further includes at least one support channel formed therein for receiving at least a portion of the laterally-extending portion when the first wall is in the collapsed position.

37. The container of claim 36, wherein the channel is formed in an exterior surface of the second wall, the channel receiving at least a portion of a support of a second container in a collapsed position and stacked thereon.

* * * * *