

(19) World Intellectual Property Organization
International Bureau



(43) International Publication Date
25 May 2001 (25.05.2001)

PCT

(10) International Publication Number
WO 01/37014 A1

- (51) International Patent Classification⁷: G02B 6/34
- (21) International Application Number: PCT/CA00/01318
- (22) International Filing Date:
14 November 2000 (14.11.2000)
- (25) Filing Language: English
- (26) Publication Language: English
- (30) Priority Data:
60/165,309 12 November 1999 (12.11.1999) US
- (71) Applicant (for all designated States except US): CME
TELEMETRIX INC. [CA/CA]; 560 Parkside Drive,
Suite 200, Waterloo, Ontario N2L 5Z4 (CA).
- (72) Inventor; and
- (75) Inventor/Applicant (for US only): PAWLUCZYK, Ro-
mund [CA/CA]; 362 Roselawn Place, Waterloo, Ontario
N2L 5P1 (CA).
- (74) Agent: BERESKIN & PARR; 40 King Street West, 40th
Floor, Toronto, Ontario M5H 3Y2 (CA).
- (81) Designated States (national): AE, AG, AL, AM, AT, AU,
AZ, BA, BB, BG, BR, BY, BZ, CA, CH, CN, CR, CU, CZ,
DE, DK, DM, DZ, EE, ES, FI, GB, GD, GE, GH, GM, HR,
HU, ID, IL, IN, IS, JP, KE, KG, KP, KR, KZ, LC, LK, LR,
LS, LT, LU, LV, MA, MD, MG, MK, MN, MW, MX, MZ,
NO, NZ, PL, PT, RO, RU, SD, SE, SG, SI, SK, SL, TJ, TM,
TR, TT, TZ, UA, UG, US, UZ, VN, YU, ZA, ZW.
- (84) Designated States (regional): ARIPO patent (GH, GM,
KE, LS, MW, MZ, SD, SL, SZ, TZ, UG, ZW), Eurasian
patent (AM, AZ, BY, KG, KZ, MD, RU, TJ, TM), European
patent (AT, BE, CH, CY, DE, DK, ES, FI, FR, GB, GR, IE,
IT, LU, MC, NL, PT, SE, TR), OAPI patent (BF, BJ, CF,
CG, CI, CM, GA, GN, GW, ML, MR, NE, SN, TD, TG).

Published:

— With international search report.

For two-letter codes and other abbreviations, refer to the "Guidance Notes on Codes and Abbreviations" appearing at the beginning of each regular issue of the PCT Gazette.

(54) Title: VOLUME OR STACKED HOLOGRAPHIC DIFFRACTION GRATINGS FOR WAVELENGTH DIVISION MULTIPLEXING AND SPECTROSCOPY

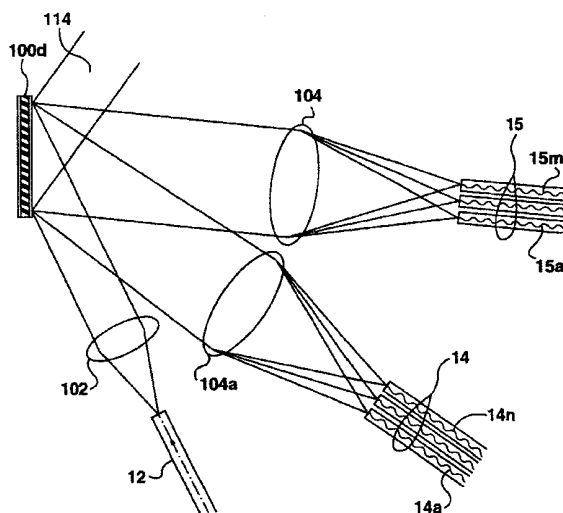

(57) Abstract: A volume diffraction grating having a substrate and an optically active layer has a structure formed in the optically active layer. The structure is operational to diffract optical signals in two selected spectral bands. The grating may be formed in a high dispersion embodiment suitable for separating individual signals from composite signals of both spectral bands. Alternatively, the grating may be formed in a low dispersion version which can separate the composite signals from each other. In another embodiment, a second structure is formed in the optically active layer. Each of the structures is configured to be operational in one of the spectral bands, allowing signals in each band to be diffracted independently of one another. In another embodiment, the structure (s) may have a curved profile allowing the diffracted beams to be shaped or focused without the need for external lenses.



WO 01/37014 A1

VOLUME OR STACKED HOLOGRAPHIC DIFFRACTION GRATINGS FOR WAVELENGTH DIVISION MULTIPLEXING AND SPECTROSCOPY

Field of the Invention

5 This invention relates to wavelength dispersing and combining gratings for spectroscopy and data transmission applications. More particularly, the invention relates to gratings that may be used to multiplex and de-multiplex spectrally separated signals into from a single optic fiber.

10 Background of the Invention

 There exist a number of technical fields (spectroscopy and telecommunications, for example) where it is necessary to spatially separate two or more optical signal which have different wavelengths or different spectral ranges (or "wavelength ranges"). In addition, it is often
15 necessary to perform the reverse operation of combining two or more optical signal having different wavelengths or spectral ranges into a single composite signal which is transmitted by a single optic fiber. The first operation is know as de-multiplexing while the second is known as multiplexing. The entire process is known as Wavelength Division
20 Multiplexing (WDM).

 A first example of a situation in which devices are required comes from the field of telecommunications. The operating spectral range of a typical optic fiber is between 1100nm to 1700 nm, which corresponds to a frequency range of 176 THz to 273 THz. Other fibers have a spectral range
25 which begins as low as 800nm or even lower. Table 1 is a list of some standardized spectral bands for optic data communication.

Table 1. Spectral Ranges, Corresponding Frequencies and Bands

Spectral Range		Frequency		RangeBand
[nm]		[GHz]		Width
From	to	From	To	[THz]
760	900	390789.5	330000.0	60.8
970	990	306185.6	300000.0	6.2
1260	1360	235714.3	218382.4	17.3
1480	1600	200675.7	185625.0	15.1
1600	1650	185625.0	180000.0	5.6
1528	1561	194117.6	189776.4	4.3

Although some of these bands have a very large bandwidth, it is not possible to generate a single optical signal which can make use of the entire bandwidth of any band. A typical optical signal comprises a data signal which is modulated onto a carrier frequency, which is the center frequency of the optical signal. The highest modulation frequency which has been achieved thus far is in the range of 1Thz. Practically achievable modulation frequencies are on the order of 100Ghz. Therefore, if only a modulator is applied to produce an optic signal in any of the spectral bands, only a small portion of the available bandwidth would be used. For example, if a signal with 100GHz bandwidth is transmitted in the band between 1260nm and 1360 nm, then only about 0.58% of the available bandwidth will be used.

One known solution to this problem is to multiplex multiple signals with different center frequencies into a single optic fiber which has an operating spectral range broader than the spectral range of the band. The spectral range of the band is divided into a number of non-overlapping channels, each of which is broad enough to allow a single signal to be modulated at a desired frequency without extending beyond the spectral

range of the channel. A separate optic signal is produced for each channel and the signals are multiplexed into a transmitting end of the optic fiber.

The combined optic signals are thus transmitted on the single optic fiber and at its opposite receiving end, they are de-multiplexed – i.e. they are
5 separated into separate signal which correspond to the original signal produced for each channel.

In addition to multiplexing a set of separate signals which are spectrally spaced in separate channels with a single spectral band to form a composite signal including of the entire set of signals within the spectral
10 band, it is possible to multiplex two or more such composite signals which have sets of signals from different spectral bands. Thus it is possible to form first composite signal having a plurality of separate signals from the spectral band, for example, between 1260 nm and 1360 nm and a second composite signal having a plurality of separate signals from the spectral
15 band, for example, between 1528 nm and 1561 nm. These two composite signals are formed using two independent multiplexing operations. The two composite signals are then multiplexed onto a single fiber, which may be called a “trunk” fiber, in a third multiplexing operation. At the opposite end of the trunk fiber, the two composite signals are first de-multiplexed from one
20 another and then the separate signals forming each composite signal are de-multiplexed in two independent operations to obtain the original optic signals.

To date, the multiplexing and de-multiplexing operations have generally been performed using reflective relief diffraction gratings, which
25 typically consist of a series of lines etched into the surface of a reflective element. Such diffraction gratings may be either high dispersion or low dispersion devices. A high dispersion reflective relief diffraction grating provides sufficient angular separate between signals in adjacent channels in a single spectral band to separate signals in those channels. A low
30 dispersion reflective relief diffraction grating has a narrower angular separation which is suitable for separating spectrally widely spaced composite signals from different spectral bands.

A high dispersion reflective relief diffraction grating cannot generally be used to separate spectrally widely spaced composite signals (or individual signals). Typically, one or both signals will be poorly diffracted or will not be diffracted at all. For example if a high dispersion reflective relief
5 diffraction grating is used as a de-multiplexer and if the incident signal (which contains two composite signals) is positioned such that one of the composite signals is properly diffracted to allow its separate signals to be separated, then the other composite signal will generally be poorly diffracted at an relatively large angle from the first composite signal.

10 If a low dispersion reflective relief diffraction grating is used to de-multiplex an incident signal contain two composite signal of different spectral bands, then the individual signals in the separate channels of each composite signal will typically not be spaced sufficiently apart to allow them to received by separate recipient optic fibers or detectors

15 Other types of gratings, including fibre Bragg diffraction gratings, free-space gratings and echelle gratings, which are used in spectroscopy applications, suffer from various deficiencies.

Summary of the Invention

20 Accordingly, there is a need for an improved diffraction grating for multiplexing and demultiplexing signals having different wavelengths in an optical communication system.

In one aspect, the present invention provides a n optical coupling device for use with first and second composite signals, said first composite
25 signal having a first spectral range and said second composite signal having a second spectral range, said device comprising a volume diffraction grating having: a substrate; an optically active layer mounted to said substrate; and a fstructure formed in said optically active layer, wherein said structure is operable in said first and second spectral ranges.

30 In a second aspect, the present invention provides a volume diffraction grating for multiplexing and demultiplexing first and second composite optical signals, said first composite optical signal having a first spectral range and said second composite optical signal having a second

spectral range, said grating comprising: a substrate; a first optically active element mounted to said substrate; and a first structure formed in said optically active element, wherein said first structure is operable in at least one of said first and second spectral ranges.

5 In a third aspect, the present invention provides a volume diffraction grating for multiplexing and demultiplexing first and second composite optical signals, said first composite optical signal having a first spectral range and said second composite optical signal having a second spectral range, said grating comprising: a substrate; an optically active element
10 mounted to said substrate; a first structure formed in said optically active element, wherein said first structure is operable in said first spectral range; and a second structure formed in said optically active element, wherein said second structure is operable in said second spectral range.

In another aspect the present invention provides a mean to improve
15 performance of free space devices for combining (multiplexing) spatially separated spectral components into a single light beam and devices for spatial separation (demultiplexing) of multiplicity of spectral components delivered in a form of a single light beam into separate light beams each of them containing single spectral component by applying suitably optimized
20 volume diffraction gratings.

Brief Description of the Drawings

The present invention will now be explained, by way of example only, with reference to the drawings, in which:

25 Figure 1A illustrates a prior art of high dispersion reflecting diffraction grating in use in communication system;

Figure 1B shows expanded view of trunk fiber bundle containing large number of fiber to collect or deliver large number of telecommunication channels;

30 Figure 2 illustrates one embodiment of a volume diffraction grating in accordance with present invention;

Figure 3A illustrates a low dispersion volume transmission diffraction grating in use in an optical communication system for extracting / combining two separate spectral bands from (into) a single fiber into (from) two fibers;

Figure 3B illustrates a high dispersion volume transmission
5 diffraction grating in use in an optical communication system for extracting / combining of large number of separate channels within a single spectral bands from / into a single fiber and into / from multiplicity of fibers;

Figure 3C illustrates another low dispersion volume reflecting
10 diffraction grating for use in an optical communication system for extracting / combining two separate spectral bands from (into) a single fiber into (from) two fibers;

Figure 3D illustrates another high dispersion volume reflecting
15 diffraction grating in use in an optical communication system for extracting / combining of large number of separate channels within a single spectral bands from / into a single fiber and into / from multiplicity of fibers;

Figure 4 illustrates another embodiment of a volume transmission diffraction grating with two separate diffraction structures for separate treatment of different spectral bands made according to the present invention;

20 Figures 5A, 5B, 5C and 5D illustrates volume transmission diffraction grating according to the present invention with incorporate two or more structures; and

Figure 6 illustrates a volume transmission diffraction grating according to the present invention with focusing power implemented into
25 grating.

Detailed Description of the Preferred Embodiments

Reference is first made to Figure 1a, which shows a prior art high dispersion imaging relief reflective diffraction grating 10 intended for use in
30 separating two composite optic signals 18a (with a spectral range of 1528nm to 1561nm, for example) and 18b (with a spectral range of 1260nm to 1360nm, for example) carried by a single fiber 12, into a first spectral a and a second spectral beam 24b. The spectral range of optic signal 18a is

divided into n channels, each of which carries an individual optical signal, having a unique center wavelength. The n channels may be closely separated (i.e. they may have a separation of 1 nm or less) within the spectral range of optic signal 18a as long as the channels do not overlap

5 Similarly, optic signal 18b comprises m non-overlapping channels each of which carries a closely separated individual optic signal within the spectral range of optical signal 18b.

Spectral beam 24a corresponds to composite optic signal 18a and is captured as a set of optical signals 29a by a bundle of optic fibers 14, whose structure is shown in Figure 1b. Spectral beam 24b corresponds to

10 optic signal 18b and is captured as a set of optic signals 29b by a second bundle of optic fibers 15.

Reference is next made to Figure 1b, which illustrates the first bundle of optic fibers 14 in greater detail. Optic fiber bundle 14 comprises a number of individual optic fibers 14a to 14n. The ends 60 of the optic fibers

15 14a to 14n are arranged in a linear array to receive spectral beam 24a. Individual optic components of spectral beam 24a, which correspond to the individual optic signals of composite optic signal 18a will be diffracted at slightly different angles by grating 10 and optic fibers 14a to 14n are

20 positioned to each receive one of those individual components. Optic fiber bundle 15 has a similar structure and comprises of a number of individual optic fibers 15a to 15m (not shown), which are similarly positioned to receive individual optic signals that form optic signal 18b.

Reference is again made to Figure 1a. While it is possible to

25 configure grating 10, which is a high dispersion relief reflective grating, to separate, or de-multiplex, one set (spectral beam 24a, for example) of closely separated spectral components within the single relatively narrow spectral band of composite signal 18a with acceptable efficiency and imaging quality, grating 10 cannot practically be used to simultaneously and

30 efficiently separate and image individual channels or optical signals in two spectral bands (i.e. the spectral bands of composite signal 18a and 18b) which are widely spectrally separated from one another. If fiber 12 and fiber bundle 14 are positioned to efficiently separate the individual optical signals

which together form composite optical signal 18a, then the spectral beam 24b will be substantially spaced from spectral beam 24a. Spectral beam 24b will generally be diffracted with low efficiency.

One reason for this is that the grating must provide an acceptable
5 angular separation of the individual optic signal in the channels of each spectral band (i.e. spectral beam 24a or 24b) to de-multiplex the closely separated channels into separate receiving fibers (i.e. fiber 14a to 14n). The angular separation of the diffracted spectral beams (24a and 24b) increases proportionally to dispersion of the grating. The construction of the
10 grating can be optimized to provide a relatively efficient angular spread out of diffracted light in one spectral band individual channels within that spectral band to be separated. The typical structure of grating 10 is shown at 30, which is an expanded view of circle 32. Grating 10 comprises a rigid backing such as glass and a highly reflective layer 36 with suitable periodic
15 microstructure. One skilled in the art will be able to configure the surface of layer 36 to diffract light efficiently in a single spectral band. However, the relatively large separation between the spectral range of two distinct spectral bands renders the same performance in two bands extremely difficult. If the grating is optimized for use with the spectral range of spectral
20 beam 24a, then spectral beam 24b will not be properly diffracted (or may not be diffracted at all). The same is true when one attempts to perform reversed operation to combine two sets of optical channels delivered by set of fibers 14 and 15 from two largely separated optical bands into a single fiber 12. In addition to difficulties related to focusing of largely separated
25 spectral band securing large, polarization independent efficiency is also extremely difficult.

A grating such as grating 10 may be configured to have a low dispersion and therefore provide a smaller and more efficient angular separation between spectral beams 24a and 24b. While this is useful for
30 separating composite signals 18a and 18b from one another, the low dispersion grating cannot sufficiently separate the individual optical signals which form composite signal 18a or composite signal 18b.

The use of prior art grating 10 as to separate spectral components from multi-wavelength signals has several additional disadvantages.

First, the precise position of diffracted beams 24a, 24b is highly dependent on the position of grating 10 which usually is very sensitive to the ambient temperature, changes of which may cause variations of angular orientation of the grating 10. For example, if grating 10 is rotated by x degrees, the position of diffracted beams 24a, 24b will move $2x$ degrees. Accordingly, it is necessary to position grating 10 precisely relative to trunk fiber 12 and branch fibers 14 and 15.

Second, grating 10 in most cases reflects and diffracts only a portion of the light contained in signals 18a, 18b in a desired direction. Typically, grating 10 will be configured to diffract the largest amount of light signal 18a and 18b into the first diffraction order (i.e. order 1) to form beams 24a and 24b, which in turn form signals 29a and 29b. The remainder of the light in signals 18a, 18b is either partially reflected by grating 10 as by a partially reflecting mirror (diffraction order 0, not shown) or diffracted in a non-preferenced directions (i.e. orders other than order 1, which are also not shown), partially absorbed by grating 10 or scattered. The scattered light corresponding to one signal (i.e. spectral band 24a intended for fiber bundle 14, for example) may be collected by individual fibers in fiber bundle 15, which is intended to collect light is spectral band 24b, causing cross-talk between channels. This may lead to signal deterioration.

Third, the active surface of a reflective diffraction grating, shown as 36 in Figure 1, cannot be readily protected. The shaping of the active surface is exposed and may easily be soiled or damaged by routine handling. Typically a grating 10 cannot be washed to remove dirt and other contaminants.

Fourth, the efficiency of grating 10 in function of wavelength shows dramatically different performance for s and p polarization. This may lead to significant variations of efficiency when plane polarized light is used and its polarization direction varies.

Reference is next made to Figure 2, which shows a volume diffraction grating 90 in accordance with the present invention. The grating

consists of a substrate 111, a cover glass 112, a first active diffraction layer 211a and a second active diffraction layer 211b. Active diffraction layer 211a is formed on one side of substrate 111. Similarly, active diffraction layer 211b is formed on one side of cover glass 112. Active diffraction layer 211a and 212 are cemented together with a layer of optical cement 113.

The diffraction layers 211a, 211b can be configured such that when an incident beam from the half space 220 strikes grating 90, a diffracted beam of a selected diffraction order propagates into the half space 222 which would contain transmitted light if the grating was fully or partially transparent, thus forming a transmissive (or "transmission") diffraction grating. Alternatively, the diffraction layers 211a, 211b may be configured such that when an incident beam from the half space 220 strikes grating 90, a diffracted beam of a selected diffraction order propagates into the half space 222 which would contain reflected light if the grating was fully or partially reflecting, thus forming a reflective diffraction grating.

Diffraction layers 211a, 211b may be formed of a dichromated gelatin or any other material which may be configured to diffract a light signal. If a dichromated gelatin or another optically active material is used, a diffraction grating may be formed by creating alternating regions of high and low refractive index within one or both diffraction layers. This is further described below in relation to diffraction grating 100.

When grating 90 is configured as a reflective diffraction grating, either substrate 111 or cover glass 112 must be made of a material that is transparent in at least the working spectral range. When grating 100 is configured as a transmissive diffraction grating, both substrate 111 and cover glass 112 must be made of material transparent in at least the working spectral range..

Both the substrate 111 and cover glass 112 can be made of filter glass to limit the spectral range of light interacting with the active diffraction layers 211a and 211b. Filter glass can also be used to modify the spectral characteristic of light diffracted by grating 90. Filtering properties of substrate 111 and cover glass 112 can be further enhanced by adding one or more interference filters 114a, 114b, 114c, 114d produced with thin layer

technology (or by another method) on any combination of substrate 111 and cover glass 112 surfaces. For example, if grating 100 is configured as a reflective transmission grating and light is incident on grating 100 from the side of cover glass 112, then interference filters 114c or 114d, or both, may be formed on the surfaces of cover glass 112. If grating 100 is configured as a transmission diffraction grating, then interference filters 114a or 114b, or both, may also be formed on the sides of substrate 111. Interference filters 114a, 114b, 114c and 114d may be used to modify the spectrum of diffracted light to compensate for spectral variation of light intensity, spectrally non-uniform response of the detector, or to compensate for spectral non-uniformity of an EDFA (erbium doped fiber optic amplifier) when system used in fiber optics telecommunication system. In addition all or selected surfaces of both substrate and cover glass can be covered with thin layer anti-reflection coating 115a, 115b, 115c and 115d to reduce possible reflection on these surfaces.

Grating 90 has been described in one preferred form. Cover glass 112, the second optically active layer 211b, cement layer 113, interference filters 114a – 114d and anti-reflection coatings 115a – 115d are optional. In its simplest form, a grating according to the present invention may consist only of a substrate (i.e. substrate 111) with a signal optically active layer (i.e. layer 211a) formed on it. Substrate 111 is required to provide a rigid backing for optically active layer 211a. When it is used, cover glass 112, along with substrate 111, protects grating 100 from damage during handling and cleaning.

Substrate 111 and cover glass 112 have been shown as planar elements. One or both of these elements may have a different shape. For example, either element or both may be a prism or may be curved in order to provide a desired optical function.

Reference is next made to Figures 3A, 3B, 3C and 3D, each of which illustrates the use of volume diffraction gratings 100a, 100b, 100c and 100d, each of which is made according to the present invention. Elements of gratings 100a – 100d identical to those of grating 90 (Figure 2) are identified by the same reference numerals. The structure of grating 100a is shown at

106, which is an expanded view of circle 108. Grating 100a comprises a substrate 111, an optically active layer 211a and a cover glass 112.

As noted above, optically active layer 211a may be a layer of a dichromated gelatin or another optically active material. As shown, grating
5 100a has alternating regions 109 with a higher refractive index and regions 110 a lower refractive index. Alternating regions 109, 110 can take different shapes (including for some applications a planar as shown at 106) and in general they do not have to be perpendicular to the plane of grating 100. In order to function efficiently as a diffractive grating, the position of consecutive
10 regions 109 having an increased refractive index must follow some predefined almost periodic function and in some cases they may become periodic (i.e. equally spaced). These regions must be properly oriented to assure proper performance in required spectral range to be diffracted by grating 100a. The shape and positioning of regions 109, 110 constitutes
15 the "structure" of the grating and this structure controls the grating's operation as a transmissive or reflection grating. In Figure 3A, grating 100a is configured as a low dispersion transmissive diffraction grating. A person skilled in the art will be capable of forming alternating regions 109 and 110 and of selecting the structure of grating 100a to diffract light of a selected
20 spectral range.

In addition to characteristics of its structure, the efficiency of grating 100a depends on other factors including the thickness T of the optically active layer 211a, the average refractive index of the optically active layer 211a, the magnitude in the difference between the refractive indexes in
25 alternating regions 109 and 111, the way in which the refractive index changes from low to high within a single period (i.e. the sharpness of the transition between regions 109 and 110), and how this transition varies in different regions of the grating. One skilled in the art will recognize that to obtain the required performance of the grating 100 all these parameters
30 must be considered. The diffraction effect is caused by refractive index variation between layers 109 and 110 in optically active layer 211a of the grating (i.e. in the volume of the grating in contrast to the diffraction on the surface as in the case of relief reflection grating 10 (Figure 1)). For this

reason gratings such as grating 90 and 100 are referred to as “volume gratings”.

Referring particularly to Figure 3B, signals 18a and 18b are two spectrally spaced sets of composite optic signals, as in Figure 1. Signal 18a may have a spectral range of 1528nm to 1561nm. Signal 18b may have a spectral range from 1260nm to 1360nm. (These ranges are only exemplary and in fact other ranges, such as those listed in Table 1, may be used.) Spectral beam 16 exits trunk fiber 12 as a divergent signal that corresponds to both signals 18a and 18b. Spectral beam 16 is collimated by lens 102. The collimated signal strikes grating 100. Grating 100a, like grating 10, diffracts spectral beam 16 into a series of spectral beams, including spectral beams 24a, 24b and 114. Spectral beam 114 is a zero order beam, which will propagate from grating 100 without being diffracted. Spectral beams 24a and 24b are first order diffracted beams corresponding to signals 18a and 18b respectively. Spectral beams 24a and 24b are angularly displaced one from another and correspond respectively to composite signals 18a, 18b. Spectral beam 24a is focused by lens 104 onto fiber bundle 14 (which is comprised of a set of n individual fibers as in Figure 2) as a set of single wavelength signals 29a corresponding to the set of individual signals which together form composite signal 18a. Similarly, beam 24b is focused by lens 104 onto fiber bundle 15 (which is comprised of a set of m individual fibers) as a set of single wavelength signals 29b which correspond to the set of individual signals which together form composite signal 18b.

By appropriately configuring its structure, a volume grating such as volume grating 90 (Figure 2) may be configured to provide an efficient high dispersion or low dispersion grating. Furthermore, a volume grating such as volume grating 90 may be configured as a transmissive or reflective grating. The following characteristics of a volume grating such as grating 90 are relevant to its operation as a high or low dispersion grating and as a transmissive or reflective grating:

- (i) thickness of active layer;
- (ii) refractive index of active medium of the grating;

- (iii) period of the grating;
- (iv) slant angle of diffraction structure to the surface of the grating;
- (v) modulation depth of refractive index;
- (vi) distribution of refractive index across the diffraction
5 microstructure; and
- (vii) angle of incidence.

A person skilled in the art will be capable of selecting and configuring these characteristics to provide a grating with the desired degree of dispersion and transmissive or reflective characteristics.

10 Figures 3A – 3D illustrate several modes of operating a volume diffraction grating. Elements in Figures 3A, 3C and 3D which correspond to elements in Figure 3B and Figure 1A are given the same reference numerals.

Figures 3A and 3B illustrate the use of diffraction gratings 100a and
15 100b as transmissive diffraction gratings. In particular, grating 100a is a low dispersion grating suitable for separating two composite signals having different spectral ranges (i.e. composite signals 18a and 18b) from one fiber (i.e. fiber 12) into two or more fibers 40 and 42.

Grating 100b is configured as a high dispersion grating which is
20 suitable for separating (or combining) individual signals in a two spectral bands into individual fibers in two separate fiber bundle (i.e. fiber bundle 14 (Figure 2) and fiber bundle 15). By properly configuring the characteristics of grating 100b, the angular separation of spectral beams 24a and 24b may be controlled so that the component signals of composite signal 18a may
25 be efficiently separated from one another while also allowing the components signals of composite signal 18b to be efficiently separated from one another.

Gratings 100c and 100d are reflective gratings which are respectively
30 configured as low and high dispersion gratings and operate respectively in a manner analogous to gratings 100a and 100b.

The low dispersion gratings 100a and 100c are designed to be efficient across the spectral range of two spaced bands. This relative

position of the fibers which receive the components signals (i.e. sets of signal 18a and 18b) will be determined by the structure of the grating.

The high dispersion gratings 100b and 100d have the advantage that they may be configured to more precisely separate signals within two
5 particular spectral ranges. However, these gratings require more precise configuration than the low dispersion gratings 100a and 100d.

Gratings 100a – 100d provide improved performance over grating 10.

First, gratings 100a and 100b are transmissive rather than reflective gratings and are consequently less sensitive to some physical movement of
10 the grating relative to trunk fiber 12 and fibers 40 and 42 or fiber bundles 14 and 15.

Second, as described above, efficiency of the grating 100 by proper selection of thickness of the active layer, its refractive index, range of variation of refractive index and its distribution across the grating, can be
15 much better controlled in terms of its value and spectral characteristics. The internal diffraction efficiency of a properly designed grating 100 may be greater than 99%, far exceeding the efficiency reflective grating available for communication systems. As a result, in addition to stronger signal, the risk of inter-channel cross talk is greatly reduced.

20 Third, as described above, the surfaces of the grating 100 can easily be protected by a cover glass or other protective material.

Fourth, one skilled in the art will recognize that the efficiency of grating 100 in diffracting a signal 18a, 18b is less sensitive to polarization of the incident signal (i.e. signals 18a, 18b) than relief grating 10.

25 Fifth, grating 100 may act as either a transmitting or reflecting allowing for different spatial arrangements injecting and collecting fibers. This allows for larger design flexibility of multiplexers and demultiplexers.

Reference is next made to Figure 4, which shows another embodiment of a grating 200 made according to the present invention.
30 Grating 200 is used in the same manner as gratings 100a to 100d (Figures 3A to 3D). Grating 200 has two independent structures. A person skilled in the art will be capable of forming two independent structures in grating 200.

The first structure, which consists of regions 202 having a high refractive index and regions 204 having a low refractive index is designed to diffract light in a relatively narrow range including the spectral range of signal 18a. Accordingly, this first structure is configured to have a band pass characteristic that diffracts light in the wavelength range for example
5 between approximately 1528 nm to 1561 nm.

The second structure consists of regions 206 having a high refractive index and regions 208 having a low refractive index and has a band pass characteristic that diffracts light in the spectral range of signal 18b, between
10 1260nm and 1360nm. All parameters of two separate diffraction structures like their period, refractive index modulation depths and distributions of refractive index across the period and across the grating can be different to independently achieve the best performance in each spectral band.

In operation, grating 200 is used in the same manner as grating
15 100a, as shown in Figure 3B. The first and second structures of grating 200 will operate independently of one another to diffract the portions of spectral beam 16 corresponding to signal 18a and 18b respectively. Compared to grating 100, grating 200 has the advantage that both its structures may be configured as high dispersion gratings which operate in a single spectral
20 range, and therefore each structure may be formed to provide a more precise diffraction of spectral beams in its respective spectral range.

Although grating 200 has only two structures, in practice, a grating may have many more structures embedded into it to allow many different sets of signals each having a different spectral range to be resolved. The
25 operation of each structure will be independent of the others, so long as the thickness T of the grating is sufficient (i.e. the volume of grating 200 is sufficient). One skilled in the art will be capable of selecting a sufficient thickness T to ensure the independent operation of the two structures.

Similarly, if a volume diffractive grating consists of two cemented
30 active layers like grating 90 (Figure 2), each layer may contain more than one diffraction structure, performing separate tasks. This even further expands capability of the present invention, allowing for the production of diffractive elements with very complex functions.

Figures 5A, 5B, 5C and 5D illustrate additional embodiment of volume diffraction gratings with two structures, like grating 200.

Figure 5A illustrates the application of low dispersion volume transmissive grating 200a with two independent diffraction structures for separation or combining of two separate spectral bands, while Fig. 5B shows application of a high dispersion grating 200b with two independent diffraction structures for independent control of diffraction geometry of both spectral bands and simultaneously for separation of telecommunication channels within each band.

Figures 5C 5D show reflective volume diffraction grating with two structures performing the same functions, respectively, as transmitting gratings 200a and 200b in Figures 5A and 5B.

When the structure of a grating is configured to operate in a relatively narrow range, it may be made more efficient. That is, if one of gratings 200a – 200d is used in the place of grating 10, more of the incident light from signal 16 that strikes grating 200 within the specific band pass ranges of the two structures will be diffracted and transmitted through lens 104 onto branch fibers 14, 15. The internal efficiency (efficiency in relation to light entering diffraction structure, which may be lower than total incident light because of possible light losses on the surface of the grating) may approach 100% for each structure in gratings 200a – 200d, depending on the characteristics of the grating. Accordingly, the risk of inter-channel cross talk is reduced even further compared with grating 10. In the case described above with reference to Figure 1b, where each of fibers 14, 15 actually carry a number of signals and are comprised of a number of fibers, then the corresponding of grating 200 must be designed to diffract wavelengths through the relevant range.

Another benefit of gratings 200a – 200d is that light outside of designed working ranges of the two structures, which are configured to operate in the spectral ranges of signal 18a and 18b, will not diffract light outside of these spectral ranges. Such light might be produced by some nearby light source and grating 200a – 200d may also acts as a noise filter to reduce the transmission of such transient light.

Reference is next made to Figure 6, which shows another embodiment of a volume transmission diffraction grating 300 according to the present invention. Grating 300 has a single structure shown more clearly at 302, which is an enlarged view of circle 304. As shown, grating 5 300 has regions 306 with a high refractive index and regions 308 with a low refractive index. The alternating regions have a curved rather a planar cross-section, in contrast to the structure of gratings 100 and 200. The shaping of regions 302 and 304 acts to modify the shape of diffracted beams 24a, 24b (which, as above, are the first order diffracted beams 10 corresponding to signals 18a, 18b).

Signals 18a, 18b are transmitted along trunk fiber 12 and exit in a divergent beam 310. Divergent beam 310 strikes grating 300, which diffracts light across a range of wavelengths including the wavelength of signals 18a, 18b, which are components of signal 16, as above. The 15 structure of grating 300 is selected to focus the first order of diffracted beams 24a, 24b corresponding to signals 18a, 18b respectively onto branch fibers 14, 15. Grating 300 does not focus the zero order beams 312 for either wavelength.

Grating 300 provides the advantage that lenses 102 and 104 are not 20 required to collimate signal 16 and to focus beams 24a, 24b. Grating 300 also provides the other advantages of grating 100 of Figure 2 over grating 10 of Figure 1.

In another embodiment (not shown) of a grating according to the present invention, the advantages of grating 300 may be combined with the 25 noise filtering and high efficiency advantages of grating 200 by making two structures in the grating. One of the structures may have a relatively narrow pass band in the spectral range of signal 18a and may be configured to focus the first order diffracted beam 24a. Similarly, the other structure may have a narrow pass band in the spectral range of signal 18b and may focus 30 the first order diffracted signal 24b.

Although these preferred embodiments of the present invention have been described with reference to separating (or demultiplexing) several signals having different wavelengths from a pair of composite signals (18a

and 18b), the embodiments are equally capable of being used to combine (or multiplex) several individual signals in two different spectral bands into a pair of composite signals which are transmitted on a single trunk fiber. combined multi-wavelength signal.

- 5 The embodiments described may be modified and varied without departing from the scope of the present invention, which is limited only by the following claims.

I claim:

1. An optical coupling device for use with first and second composite signals, said first composite signal having a first spectral range and said
5 second composite signal having a second spectral range, said device comprising
 - (a) a volume diffraction grating having:
 - (i) a substrate;
 - (ii) an optically active layer mounted to said substrate; and
 - 10 (iii) a fstructure formed in said optically active layer, wherein said structure is operable in said first and second spectral ranges.
2. The device of claim 1 wherein said structure is configured to provide
15 a first diffracted spectral beam corresponding to said first composite signal and a second diffracted spectral beam corresponding to said second composite signal, wherein said first and second spectral beams have an angular separation.
- 20 3. The device of claim 1 further comprising an incident lens for receiving said first and second composite signals and for providing first and second collimated signals corresponding to said first and second composite signals, said first and second collimated signal being incident on said volume diffraction grating.
- 25 4. The device of claim 2 further comprising a focusing lens for receiving said first and second diffracted spectral beams and for focusing said first diffracted beam onto a first receiving element and for focusing said second diffracted beam onto a second receiving element.
- 30 5. The device of claim 4 wherein said first receiving element is a first receiving optic fiber and said second receiving element is a second receiving optic fiber.

6. The device of claim 1 wherein said structure is configured: (i) to receive a first incident spectral beam and a second incident spectral beam; (ii) to diffract said first incident spectral beam to provide said first composite
5 signal; and (iii) to diffract said second incident spectral beam to provide said second composite signal.

7. The device of claim 1 wherein said first composite signal has a first set of closely separated component signals within said first spectral range and said second composite signal has a second set of closely separated
10 component signals within said second spectral range, and wherein said structure is configured to diffract each of said component signals in said first set of closely separated component signals into one fiber in a first set of receiving fibers and to diffract each of said component signals in said
15 second set of closely separated component signals into one fiber in a second set of receiving fibers.

8. The device of claim 1 wherein said structure has a curved configuration.

20

9. A volume diffraction grating for multiplexing and demultiplexing first and second composite optical signals, said first composite optical signal having a first spectral range and said second composite optical signal having a second spectral range, said grating comprising:

25

- (a) a substrate;
- (b) an optically active element mounted to said substrate;
- (c) a first structure formed in said optically active element, wherein said first structure is operable in said first spectral range; and
- (d) a second structure formed in said optically active element,
30 wherein said second structure is operable in said second spectral range.

10. The grating of claim 9 wherein said first structure is configured to diffract spectral beams of said first spectral range and said second structure is configured to diffract spectral beams of said second spectral range.

5

11. A volume diffraction grating for multiplexing and demultiplexing first and second composite optical signals, said first composite optical signal having a first spectral range and said second composite optical signal having a second spectral range, said grating comprising:

- 10 (a) a substrate;
- (b) a first optically active element mounted to said substrate;
- (c) a first structure formed in said optically active element, wherein said first structure is operable in at least one of said first and second spectral ranges.

15

12. The volume diffraction grating of claim 11 wherein said substrate is formed of optical filter glass, wherein said optical filter glass is transparent at least one of said first or second spectral range.

20 13. The volume diffraction grating of claim 11 or 12 further comprising a thin layer filter coating on at least one side of said substrate, said thin layer filter coating operable to modify the spectral content of light incident on said grating.

25 14. The volume diffraction grating of claim 11, 12 or 13 further comprising a thin layer antireflection coating on at least one side of said substrate.

15. The volume diffraction grating of claim 11, 12, 13 or 14 further comprising a second structure formed in said first optically active element.

30

16. The volume diffraction grating of claim 11, 12, 13, 14 or 15 further comprising a cover glass wherein said first optically active element is positioned between said substrate and said cover glass.

17. The volume diffraction grating claim 16 further comprising a second optically active layer mounted to said cover glass and an optically transparent cement layer coupling said first optically active element to said
5 second optically active element.

18. The volume diffraction grating of claims 11, 12, 13, 14 or 15 wherein said cover glass is coupled to said first optically active element with an optically opaque cement.
10

19. The volume diffraction grating of claim 16, 17 or 18 wherein said cover glass is opaque in at least one of said first or second spectral ranges.

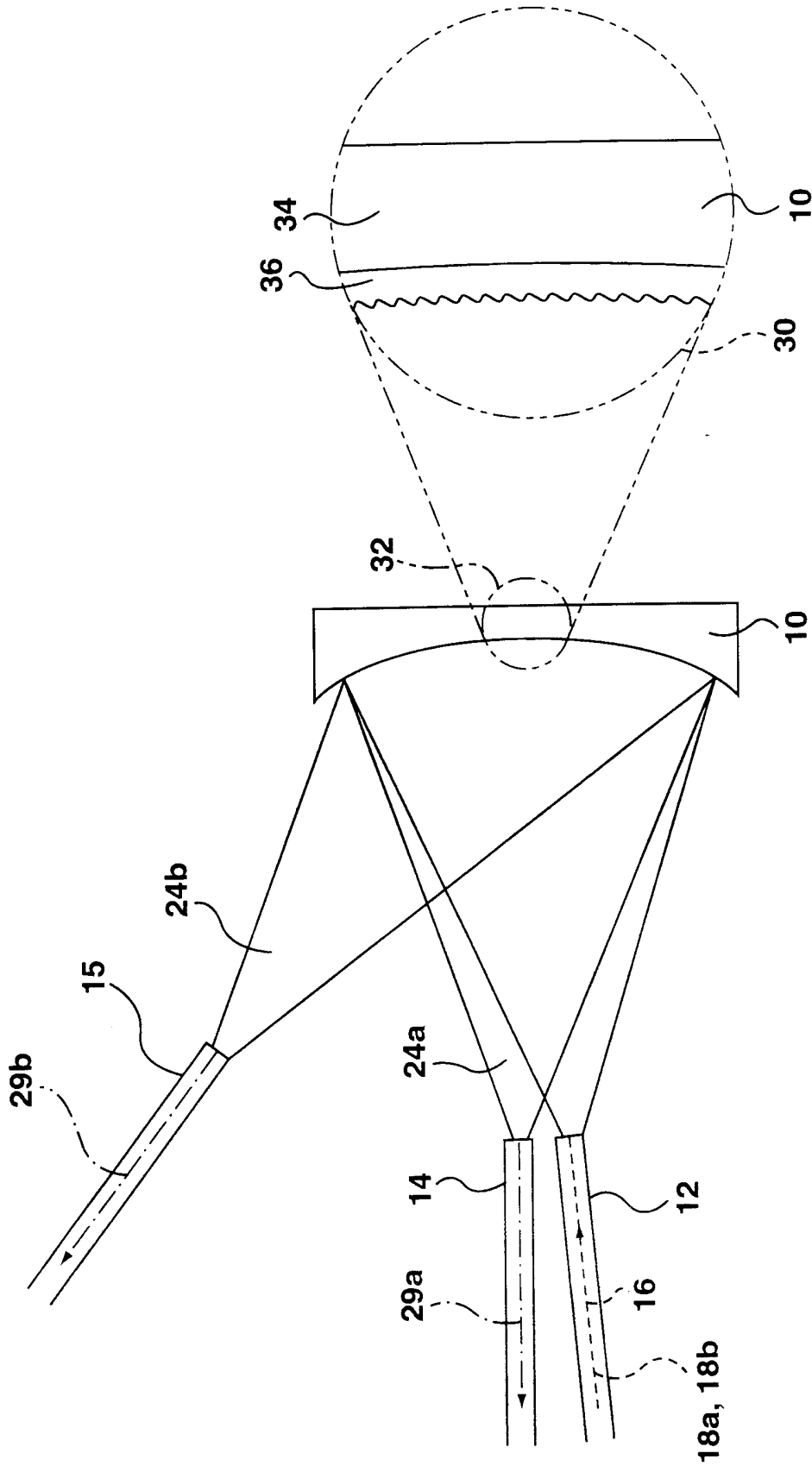

FIG. 1A

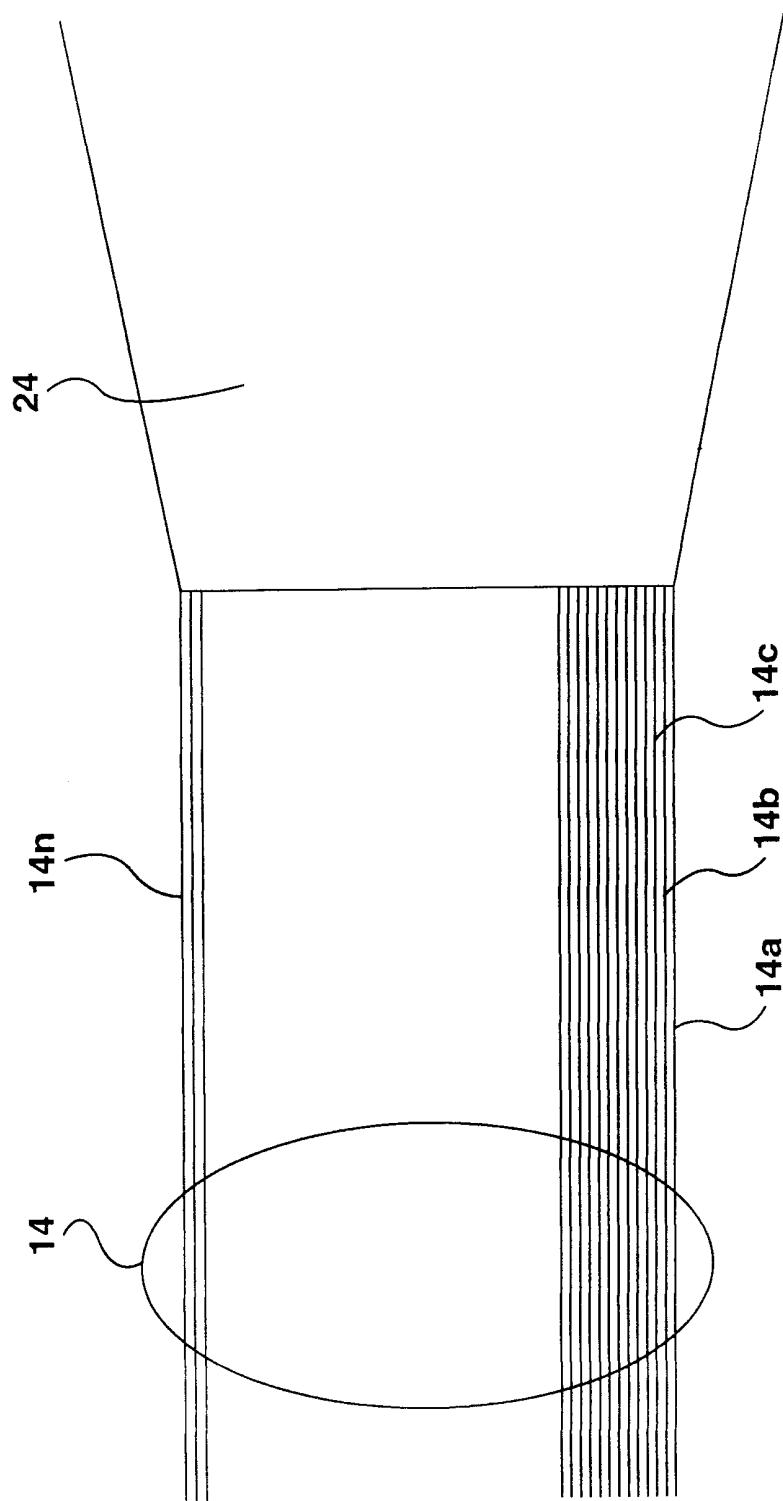

FIG. 1B

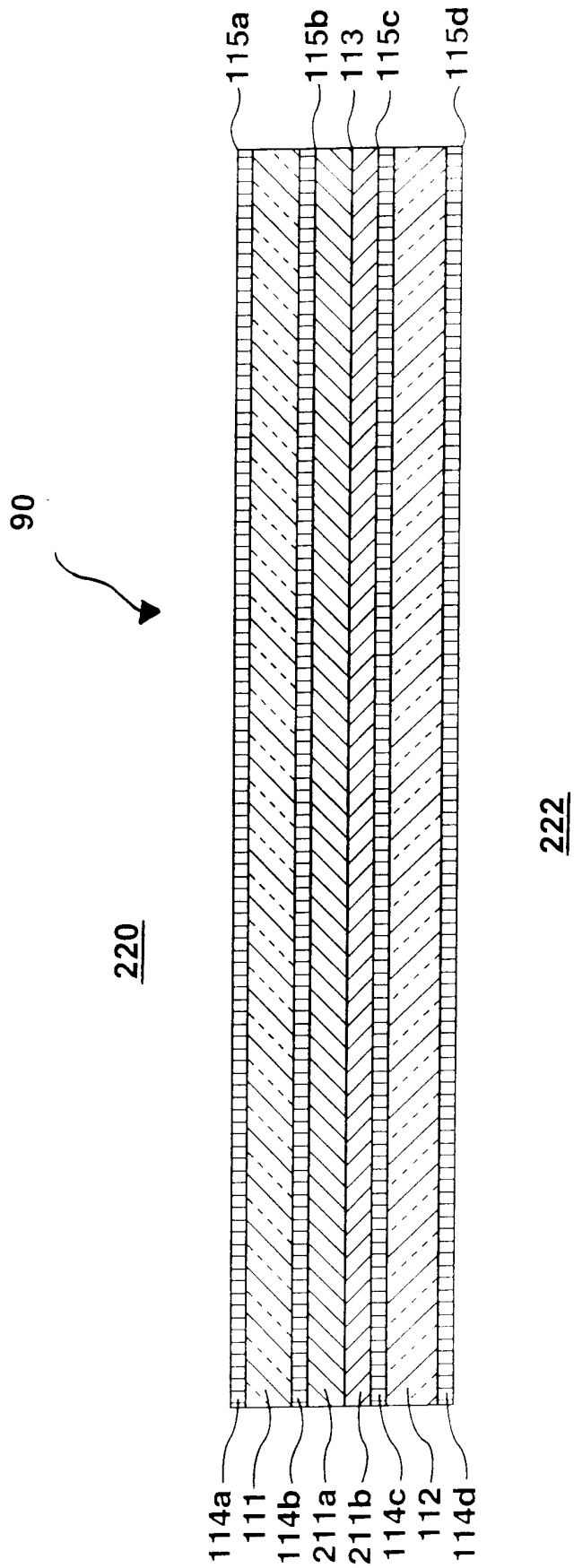

FIG. 2

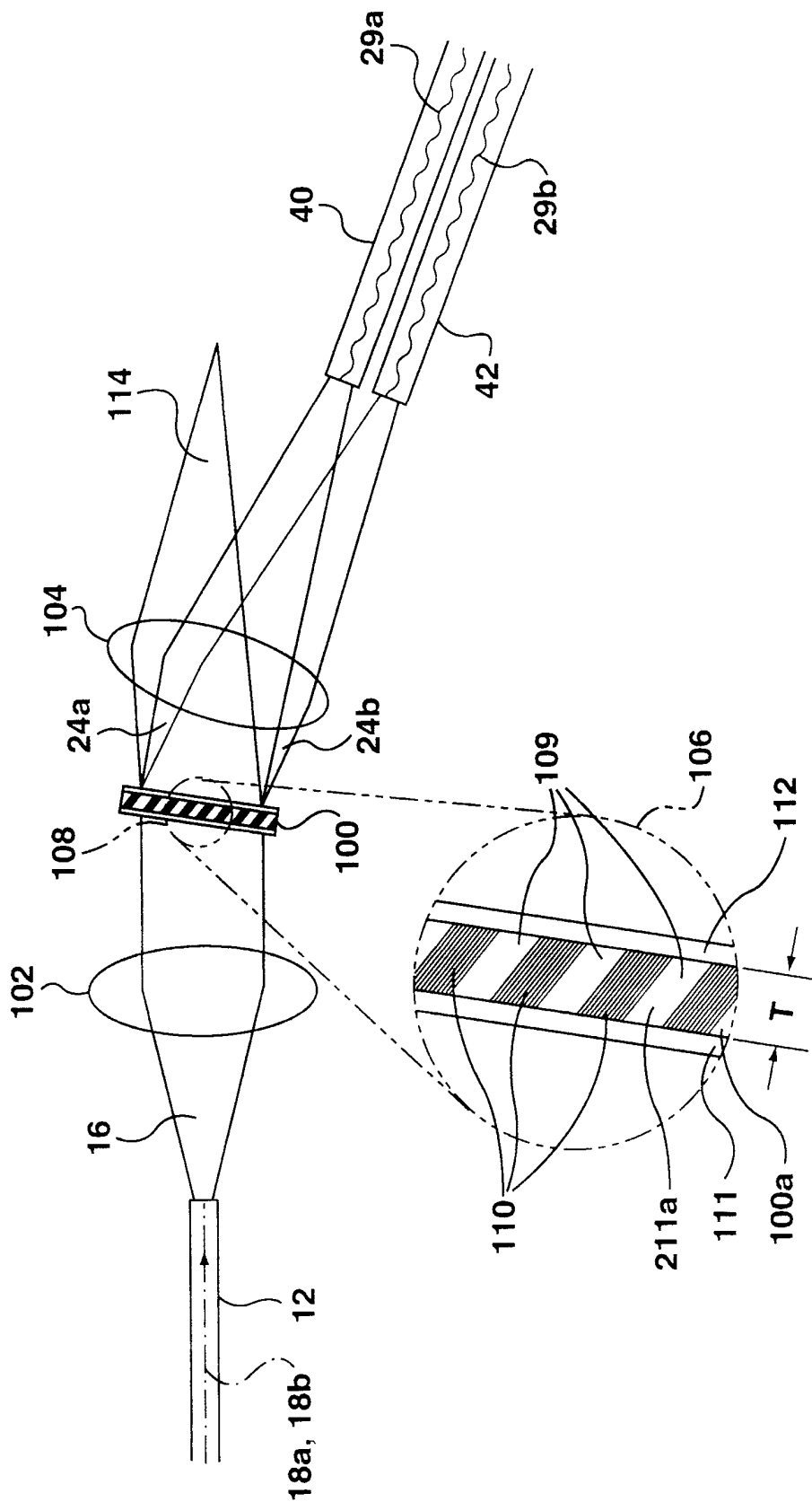

FIG. 3A

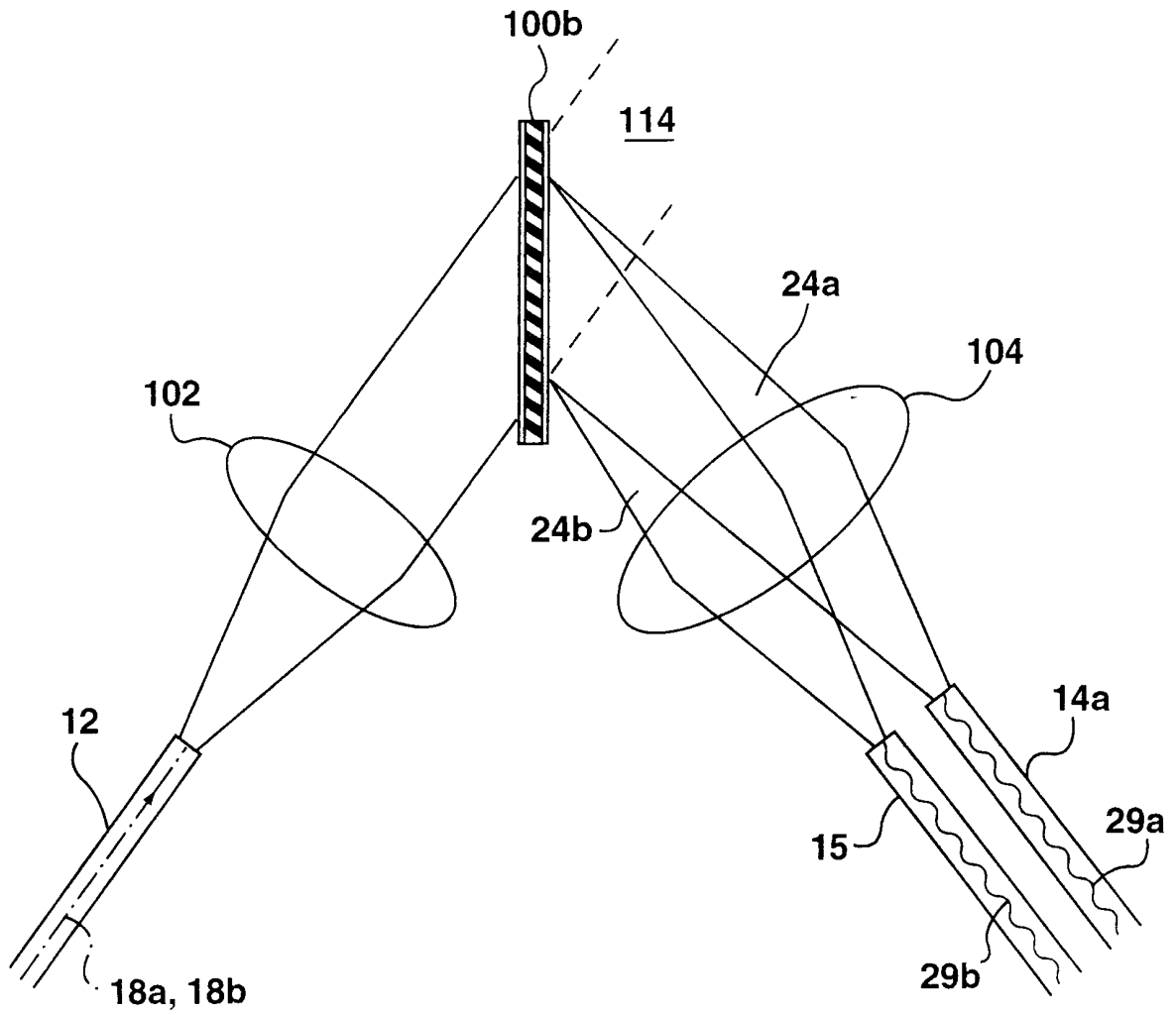

FIG. 3B

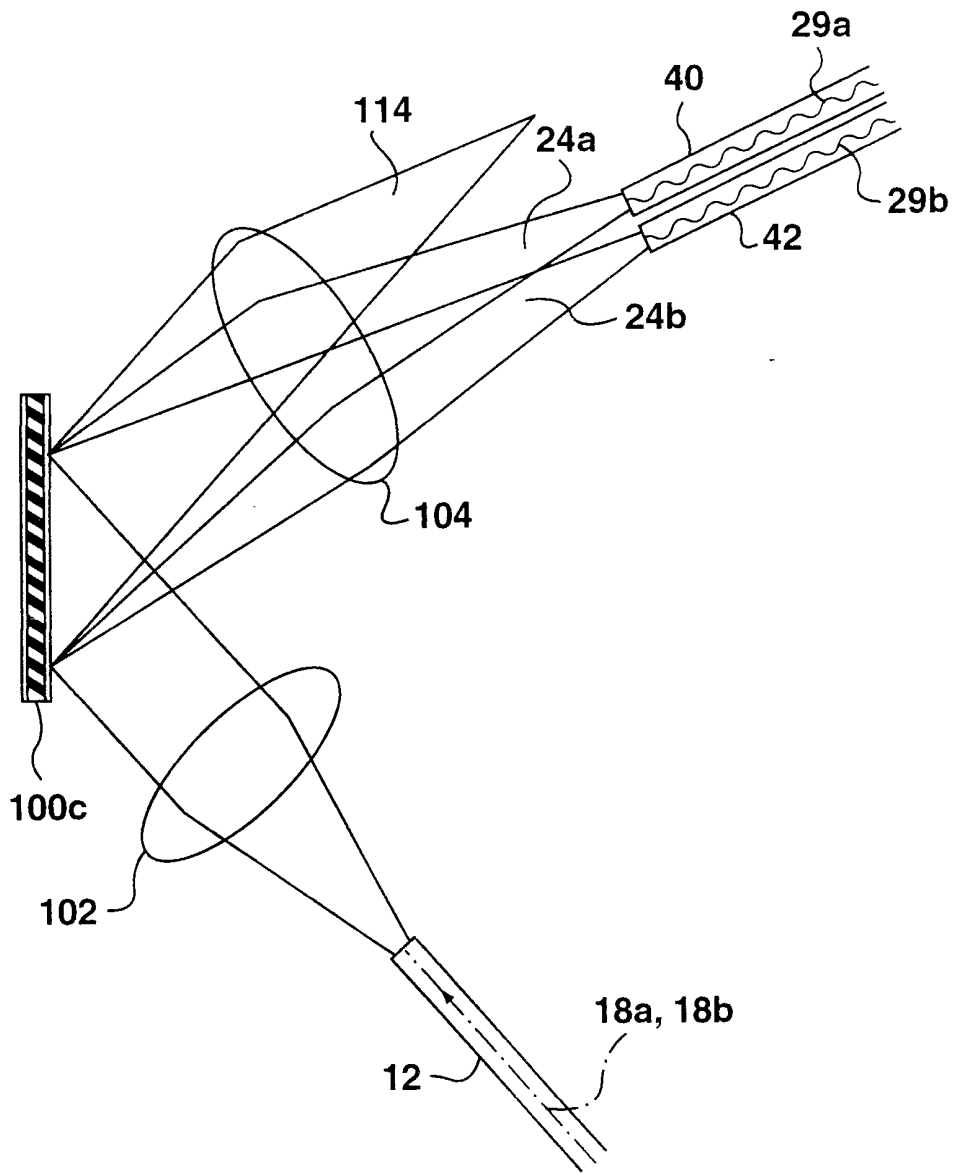

FIG. 3C

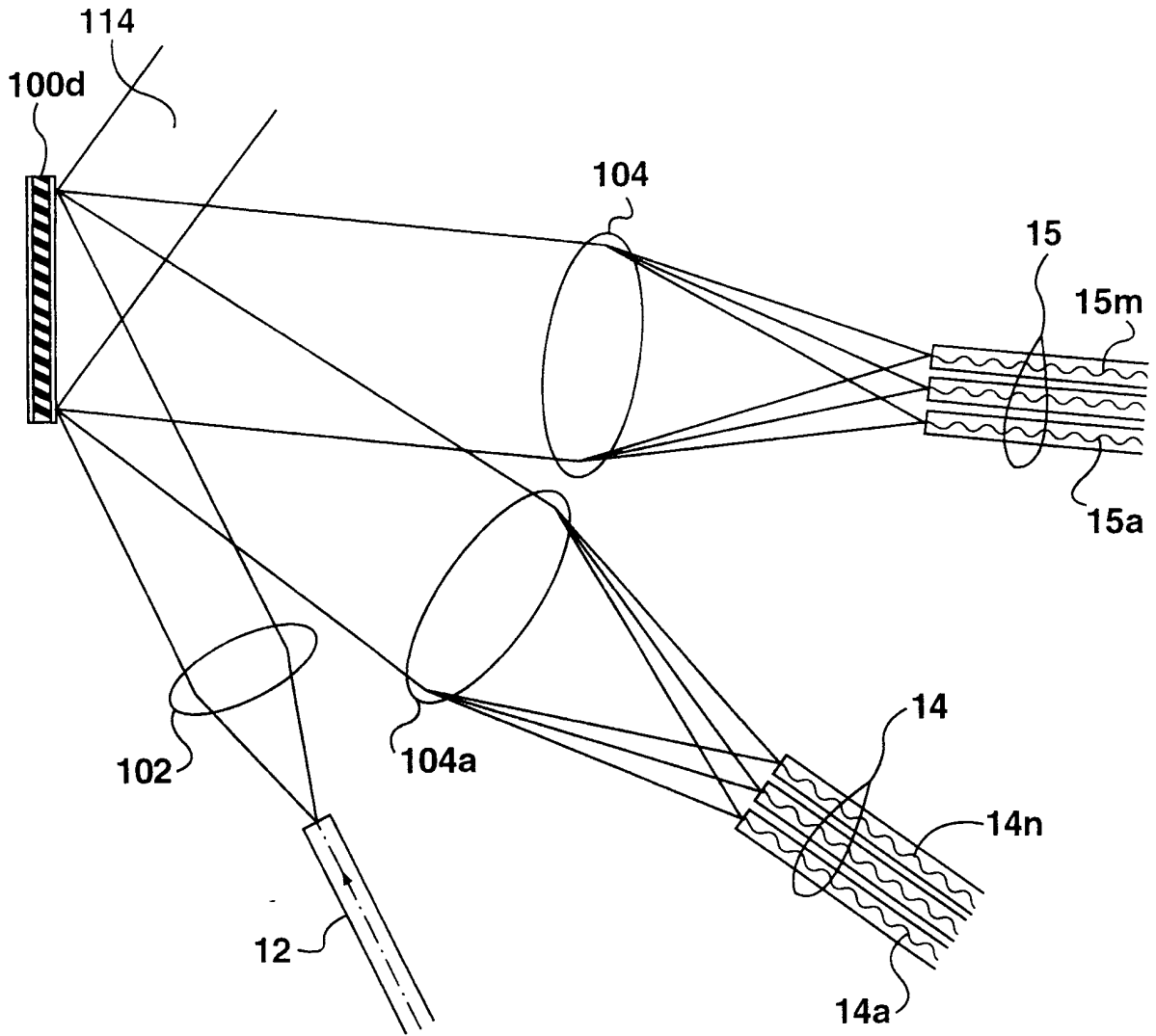

FIG. 3D

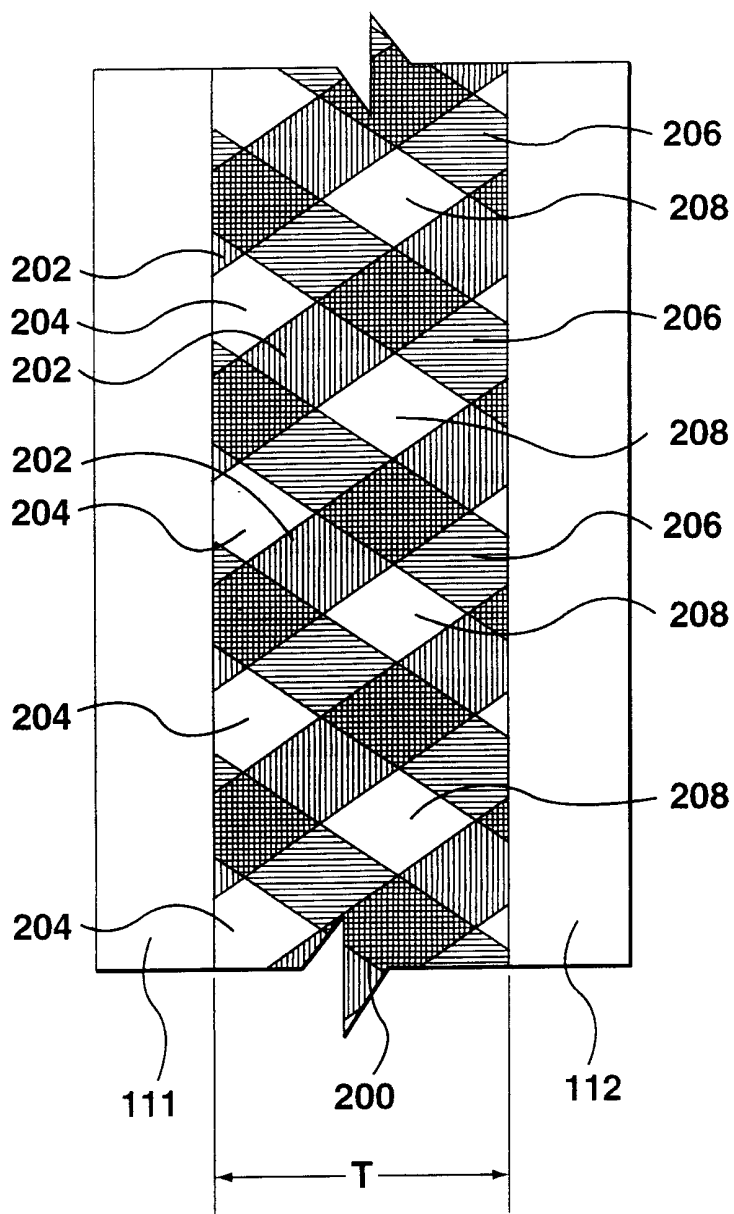

FIG. 4

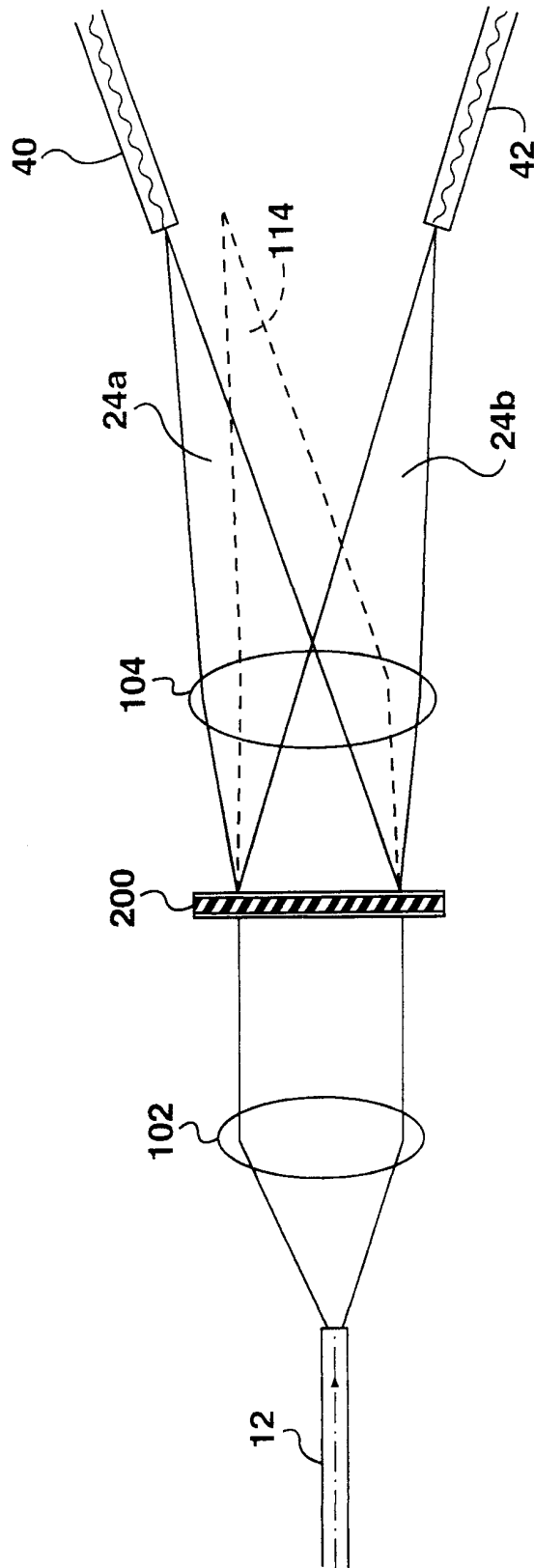

FIG. 5A

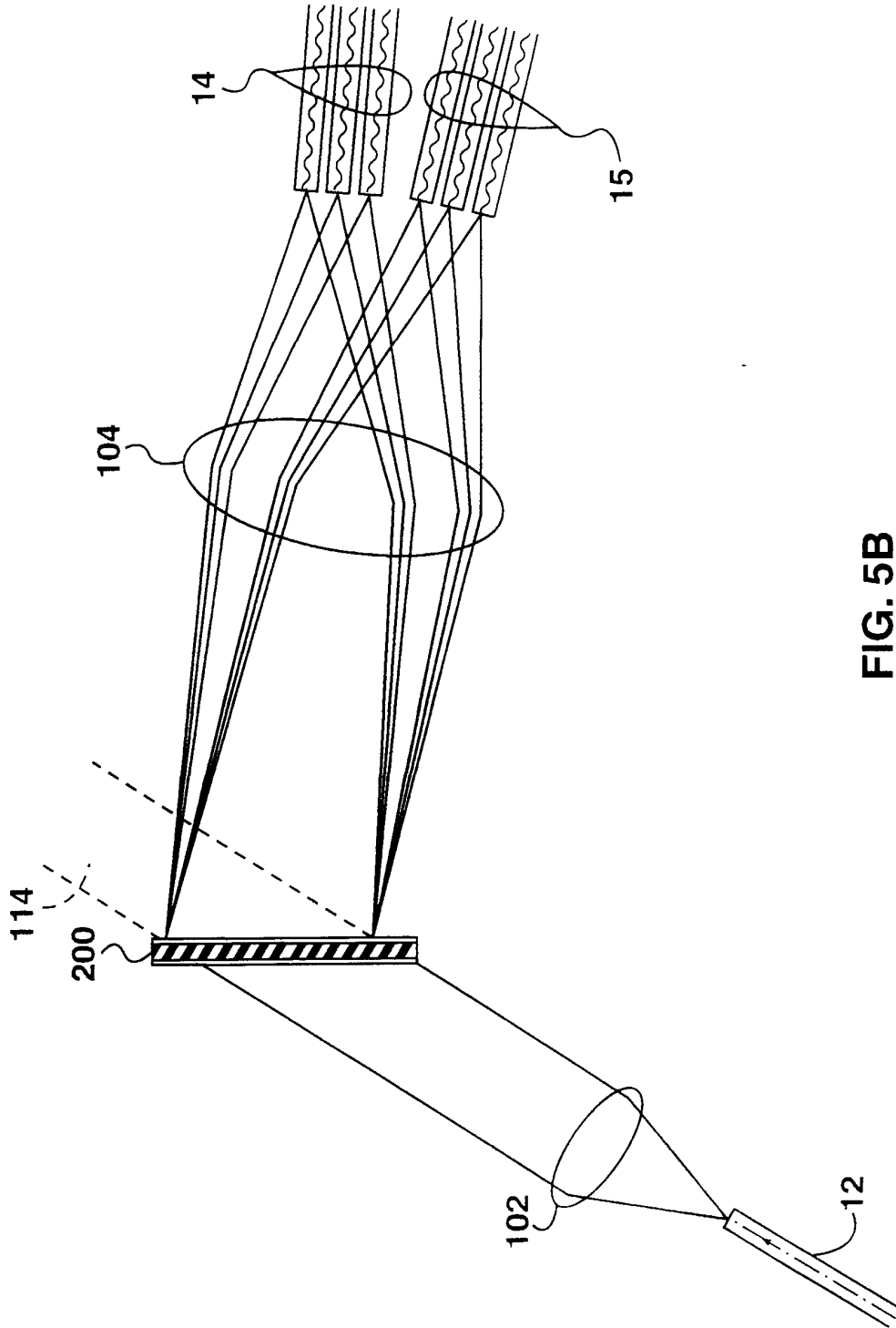

FIG. 5B

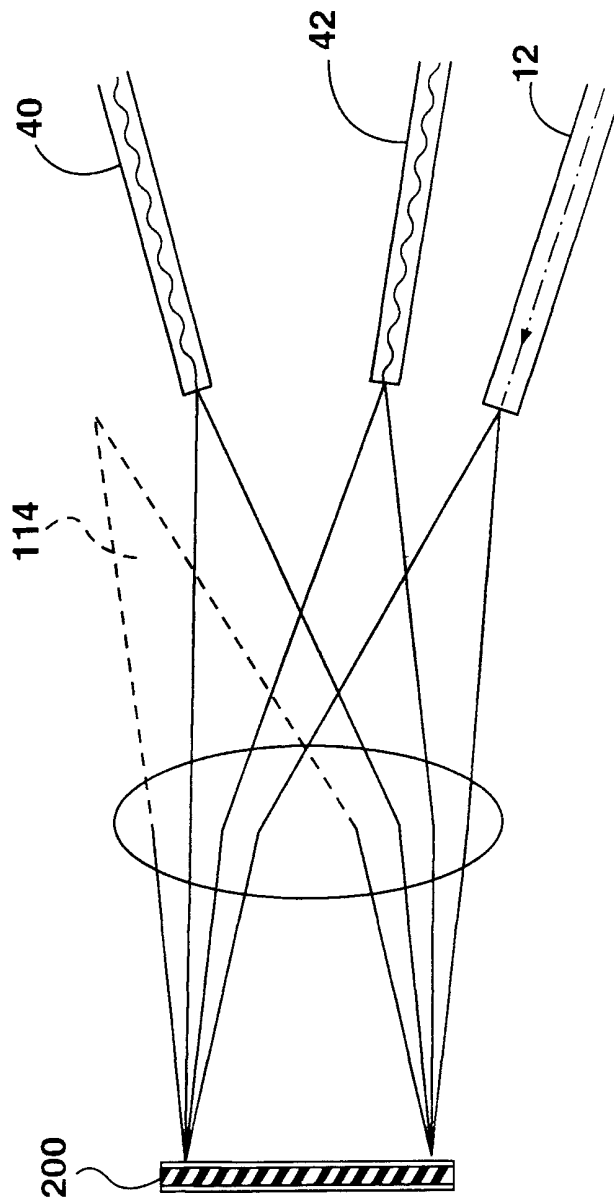

FIG. 5C

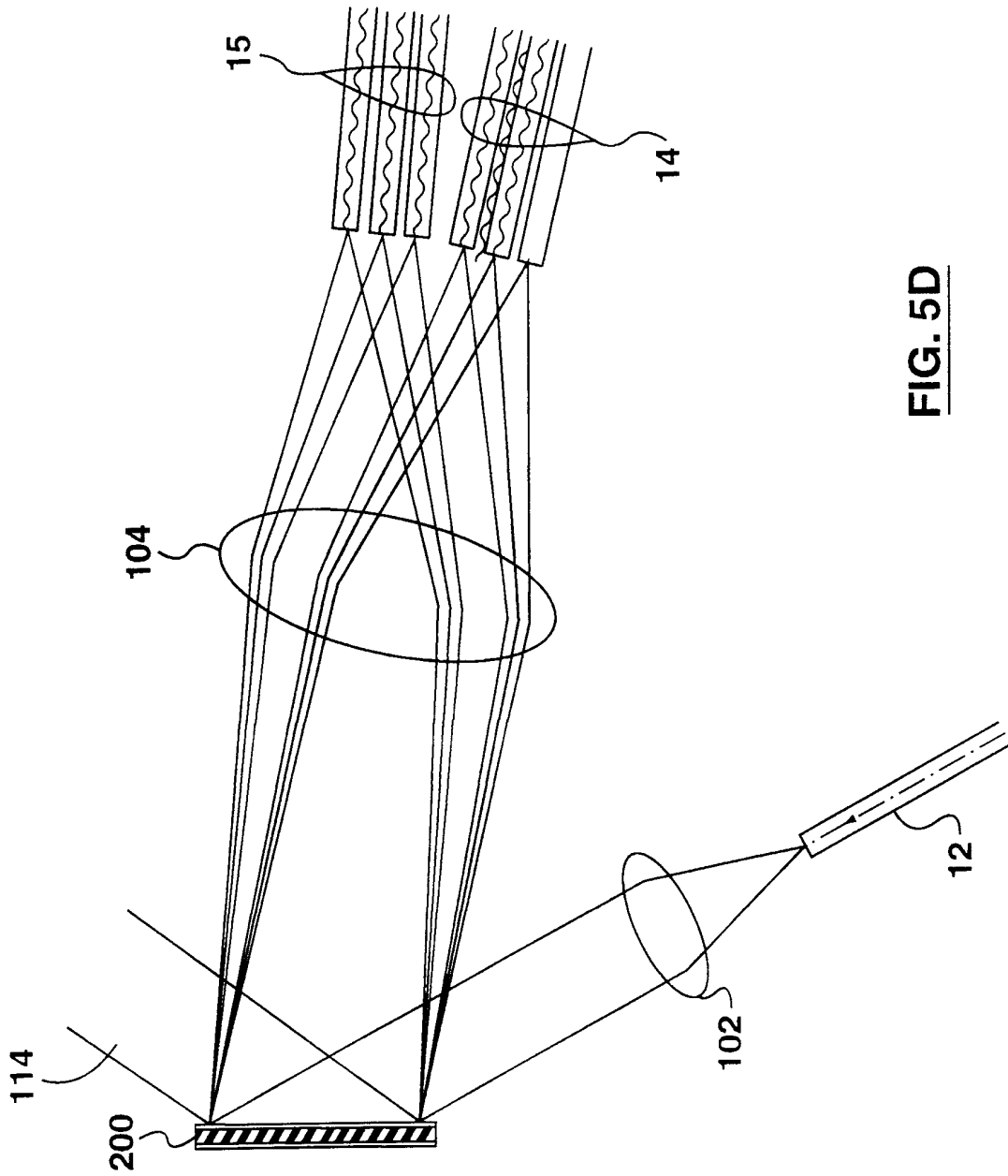

FIG. 5D

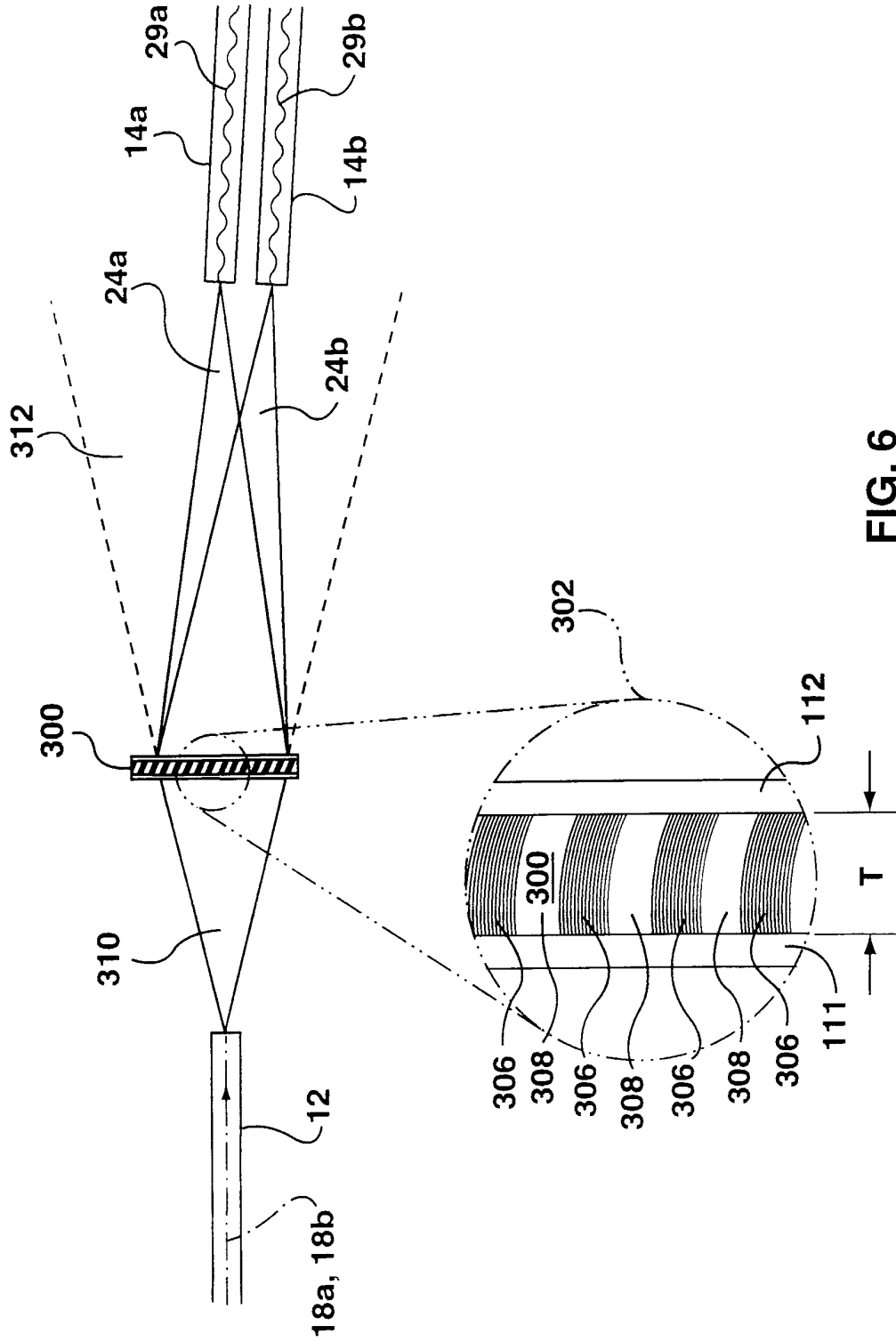

FIG. 6

INTERNATIONAL SEARCH REPORT

International Application No
PCT/CA 00/01318

A. CLASSIFICATION OF SUBJECT MATTER
IPC 7 G02B6/34

According to International Patent Classification (IPC) or to both national classification and IPC

B. FIELDS SEARCHED

Minimum documentation searched (classification system followed by classification symbols)
IPC 7 G02B G01J

Documentation searched other than minimum documentation to the extent that such documents are included in the fields searched

Electronic data base consulted during the international search (name of data base and, where practical, search terms used)

EPO-Internal, PAJ, INSPEC, WPI Data

C. DOCUMENTS CONSIDERED TO BE RELEVANT

Category *	Citation of document, with indication, where appropriate, of the relevant passages	Relevant to claim No.
X	US 5 442 439 A (BATTEY DAVID E ET AL) 15 August 1995 (1995-08-15) the whole document ---	1-4,6,7, 11,15
X	WANG M R ET AL: "SUBSTRATE WAVELENGTH-DEMULTIPLEXING OPTICAL INTERCONNECTS BASED ON SUPERIMPOSED HOLOGRAPHIC GRATINGS AND THREE-DIMENSIONAL BRAGG DIFFRACTION" OPTICS LETTERS,US,OPTICAL SOCIETY OF AMERICA, WASHINGTON, vol. 18, no. 23, 1 December 1993 (1993-12-01), pages 2068-2070, XP000413244 ISSN: 0146-9592 the whole document --- -/--	1,9-11

Further documents are listed in the continuation of box C.

Patent family members are listed in annex.

* Special categories of cited documents :

- *A* document defining the general state of the art which is not considered to be of particular relevance
- *E* earlier document but published on or after the international filing date
- *L* document which may throw doubts on priority claim(s) or which is cited to establish the publication date of another citation or other special reason (as specified)
- *O* document referring to an oral disclosure, use, exhibition or other means
- *P* document published prior to the international filing date but later than the priority date claimed

- *T* later document published after the international filing date or priority date and not in conflict with the application but cited to understand the principle or theory underlying the invention
- *X* document of particular relevance: the claimed invention cannot be considered novel or cannot be considered to involve an inventive step when the document is taken alone
- *Y* document of particular relevance: the claimed invention cannot be considered to involve an inventive step when the document is combined with one or more other such documents, such combination being obvious to a person skilled in the art.
- *&* document member of the same patent family

Date of the actual completion of the international search <p style="text-align: center; font-size: 1.2em;">1 March 2001</p>	Date of mailing of the international search report <p style="text-align: center; font-size: 1.2em;">08/03/2001</p>
Name and mailing address of the ISA European Patent Office, P.B. 5818 Patentlaan 2 NL - 2280 HV Rijswijk Tel. (+31-70) 340-2040. Tx. 31 651 epo nl. Fax: (+31-70) 340-3016	Authorized officer <p style="text-align: center; font-size: 1.2em;">Faderl, I</p>

INTERNATIONAL SEARCH REPORT

International Application No
PCT/CA 00/01318

C.(Continuation) DOCUMENTS CONSIDERED TO BE RELEVANT		
Category *	Citation of document, with indication, where appropriate, of the relevant passages	Relevant to claim No.
Y	DE CASTRO CARRANZA C ET AL: "HOLOGRAPHIC GRATING WITH TWO SPATIAL FREQUENCIES FOR THE SIMULTANEOUS STUDY OF TWO SPECTRAL PROFILES" APPLIED OPTICS, US, OPTICAL SOCIETY OF AMERICA, WASHINGTON, vol. 31, no. 16, 1 June 1992 (1992-06-01), pages 3131-3133, XP000274828 ISSN: 0003-6935 page 3131, column 1, paragraph 2 page 3133, column 2, paragraph CONCLUSIONS ---	1-4, 11, 12, 14-17
Y	US 4 671 603 A (MCQUOID JAMES A ET AL) 9 June 1987 (1987-06-09) column 3, line 20 - line 30 column 5, line 1 - line 13 ---	1-4, 11, 12, 14-17
A	US 4 337 993 A (KOMPFFNER RUDOLF) 6 July 1982 (1982-07-06) abstract; figures column 1, line 1 - column 2, line 23 column 3, line 9 - line 18 ---	1, 3-6, 8-11, 15
A	US 5 966 223 A (AMITAI YAAKOV ET AL) 12 October 1999 (1999-10-12) figure 11 ---	12, 15, 16
A	FR 2 579 044 A (COMMISSARIAT ENERGIE ATOMIQUE) 19 September 1986 (1986-09-19) -& US 4 740 951 A (JACQUES LIZET ET AL) 26 April 1988 (1988-04-26) column 4, line 4 - line 15 abstract; figures ---	1, 9, 11
A	US 4 540 246 A (FANTONE STEPHEN D) 10 September 1985 (1985-09-10) abstract column 2, line 3 - line 64 ---	1, 9, 11
A	PATENT ABSTRACTS OF JAPAN vol. 010, no. 038 (P-428), 14 February 1986 (1986-02-14) & JP 60 184217 A (NIPPON DENSHIN DENWA KOSHA), 19 September 1985 (1985-09-19) abstract -----	13

INTERNATIONAL SEARCH REPORT

Information on patent family members

International Application No

PCT/CA 00/01318

Patent document cited in search report	Publication date	Patent family member(s)	Publication date
US 5442439 A	15-08-1995	EP 0736168 A	09-10-1996
		JP 8509293 T	01-10-1996
		WO 9424527 A	27-10-1994
		US 5559597 A	24-09-1996
US 4671603 A	09-06-1987	DE 3441689 A	30-05-1985
		FR 2555324 A	24-05-1985
		GB 2151036 A,B	10-07-1985
		JP 60119507 A	27-06-1985
US 4337993 A	06-07-1982	GB 1549186 A	01-08-1979
		DE 2644740 A	14-04-1977
		JP 1245934 C	25-12-1984
		JP 52044654 A	07-04-1977
		JP 59021528 B	21-05-1984
US 5966223 A	12-10-1999	EP 0746783 A	11-12-1996
		JP 8507879 T	20-08-1996
		WO 9419712 A	01-09-1994
		US 5682255 A	28-10-1997
FR 2579044 A	19-09-1986	DE 3674615 D	08-11-1990
		EP 0196948 A	08-10-1986
		JP 61212805 A	20-09-1986
		US 4740951 A	26-04-1988
US 4540246 A	10-09-1985	CA 1247410 A	27-12-1988
		DE 3484111 D	28-03-1991
		EP 0121369 A	10-10-1984
		JP 1797634 C	28-10-1993
		JP 5007684 B	29-01-1993
		JP 59184314 A	19-10-1984
JP 60184217 A	19-09-1985	JP 1423521 C	15-02-1988
		JP 62031323 B	08-07-1987