



(19) **United States**

(12) **Patent Application Publication**
Blomquist et al.

(10) **Pub. No.: US 2012/0013625 A1**

(43) **Pub. Date: Jan. 19, 2012**

(54) **DISPLAY FOR PUMP**

Publication Classification

(76) Inventors: **Michael Blomquist**, Blaine, MN (US); **Timothy Bresina**, Shoreview, MN (US); **Gail Bynum**, Brooklyn Park, MN (US); **Michael Welsch**, Stillwater, MN (US)

(51) **Int. Cl.**
G06F 13/14 (2006.01)
(52) **U.S. Cl.** **345/520**

(21) Appl. No.: **13/242,116**

(57) **ABSTRACT**

(22) Filed: **Sep. 23, 2011**

This document discusses, among other things, an apparatus comprising a pump configured to deliver insulin, a processor, and a user interface including a bistable display. A display element of the bistable display is placed in one of two stable orientations upon application of a biasing voltage and stays in the stable orientation when the biasing voltage is removed. The processor includes a display module configured to display a non-blank reversion display screen on the bistable display when no input is received at the user interface after a specified time duration, and to recurrently change the reversion display screen until input is received at the user interface.

Related U.S. Application Data

(62) Division of application No. 12/114,033, filed on May 2, 2008.

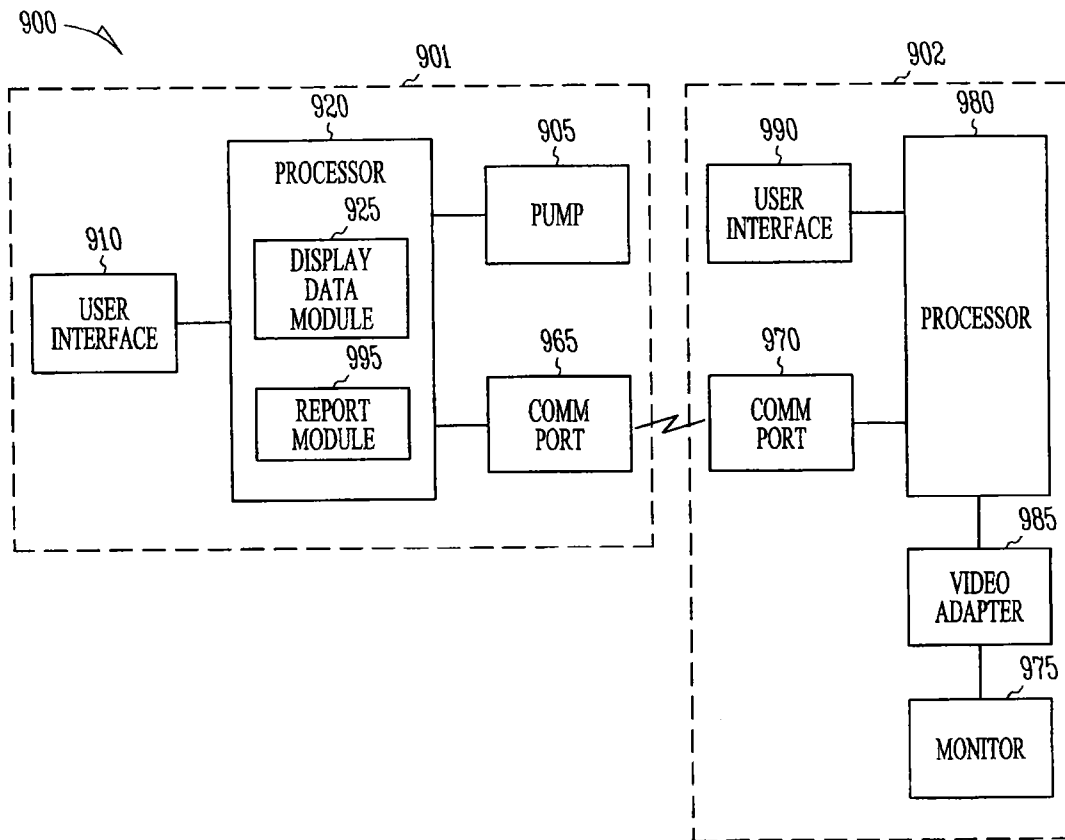

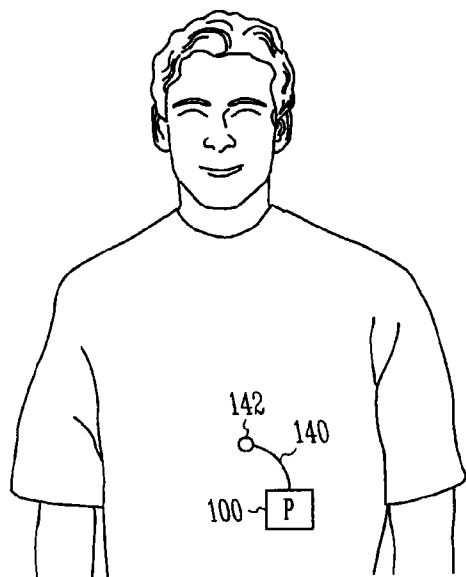

FIG. 1A

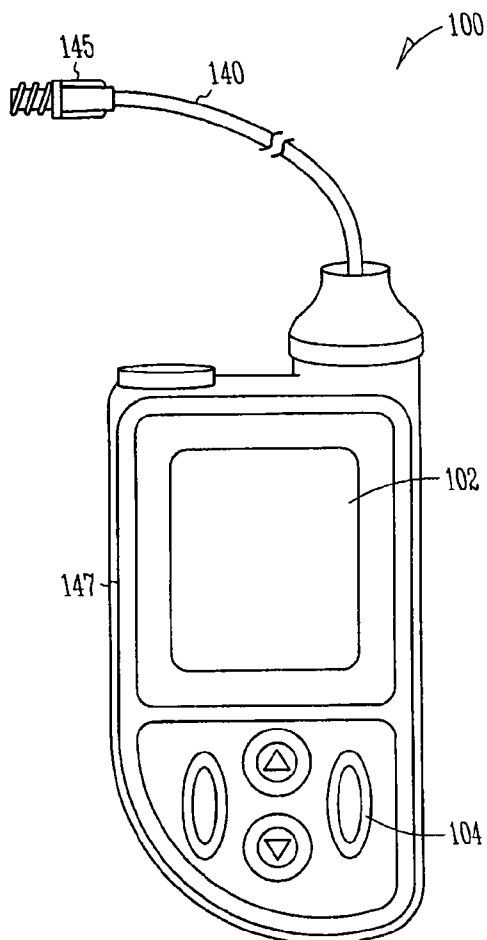

FIG. 1B

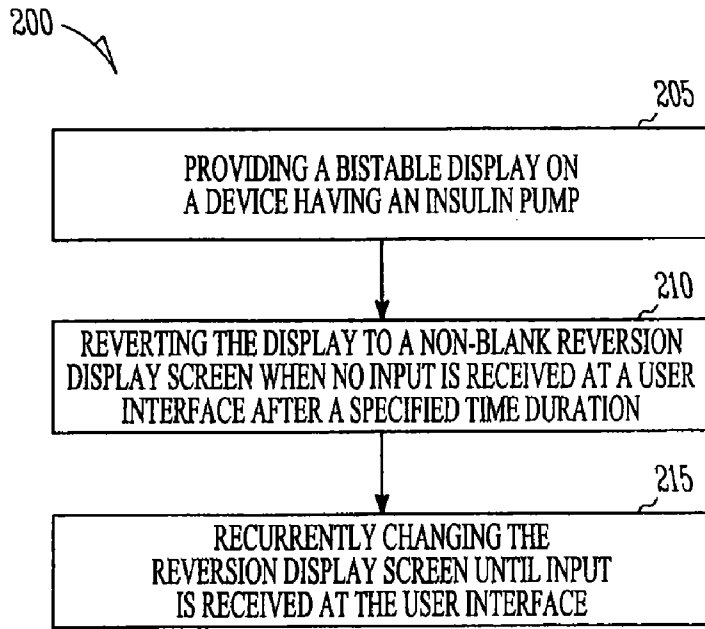

FIG. 2

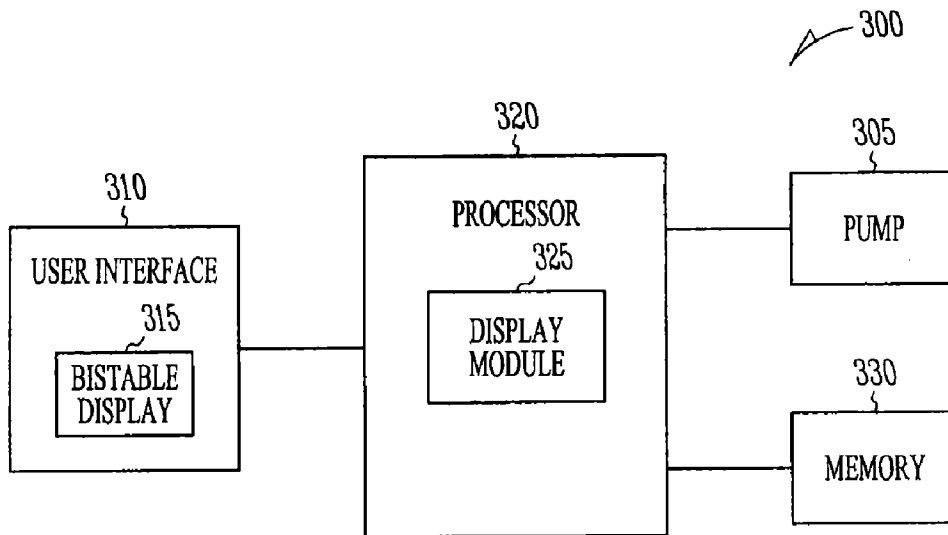

FIG. 3

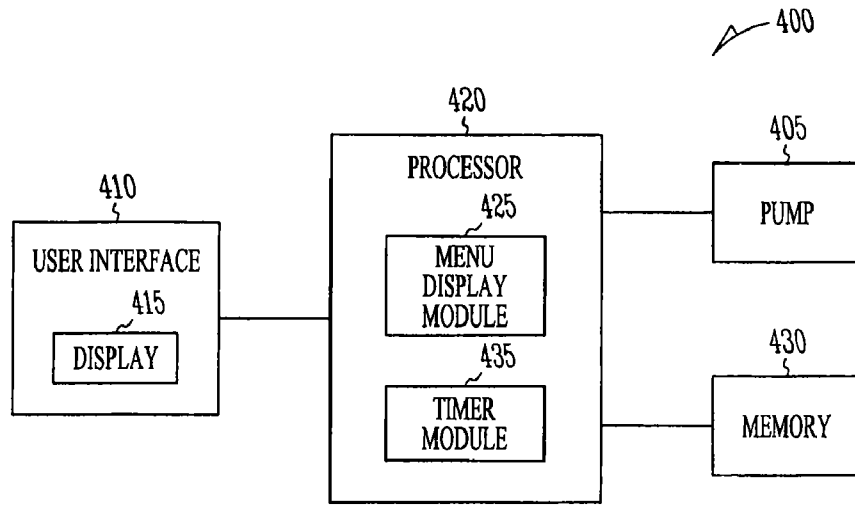

FIG. 4

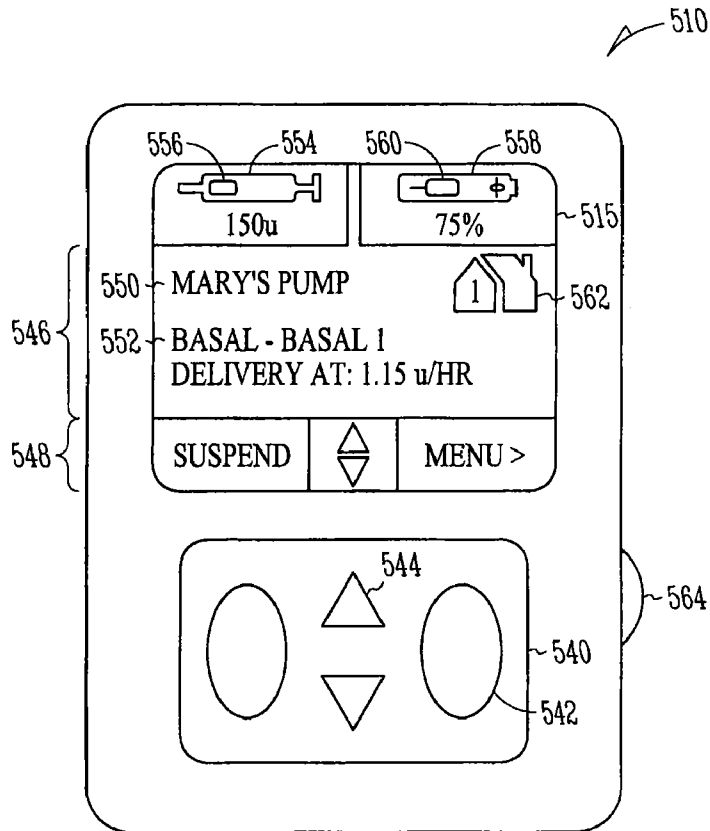

FIG. 5

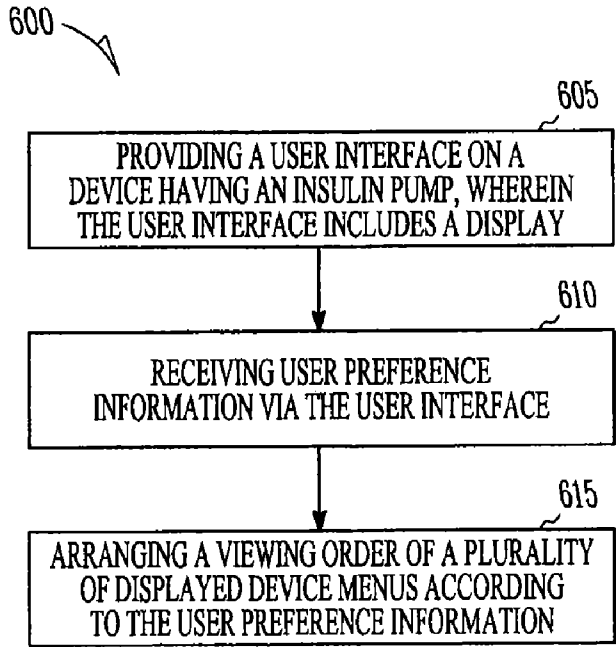

FIG. 6

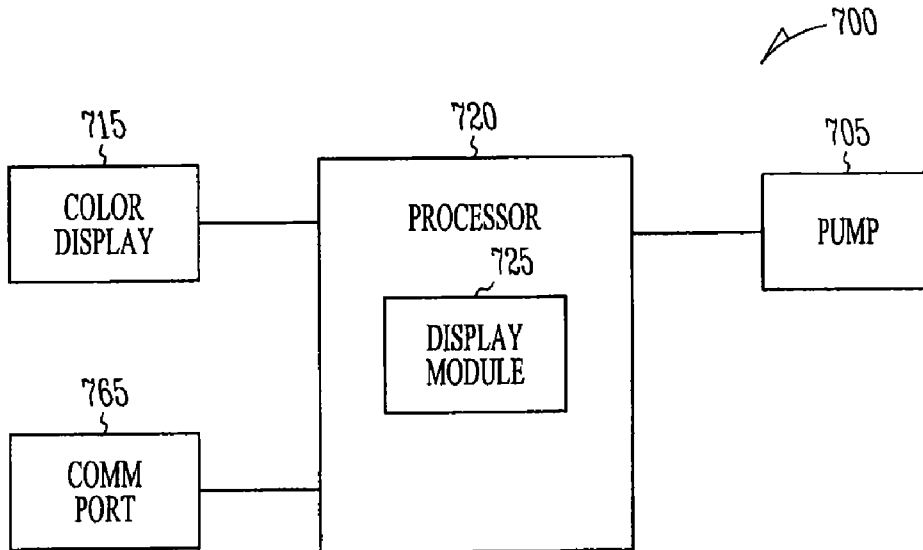

FIG. 7

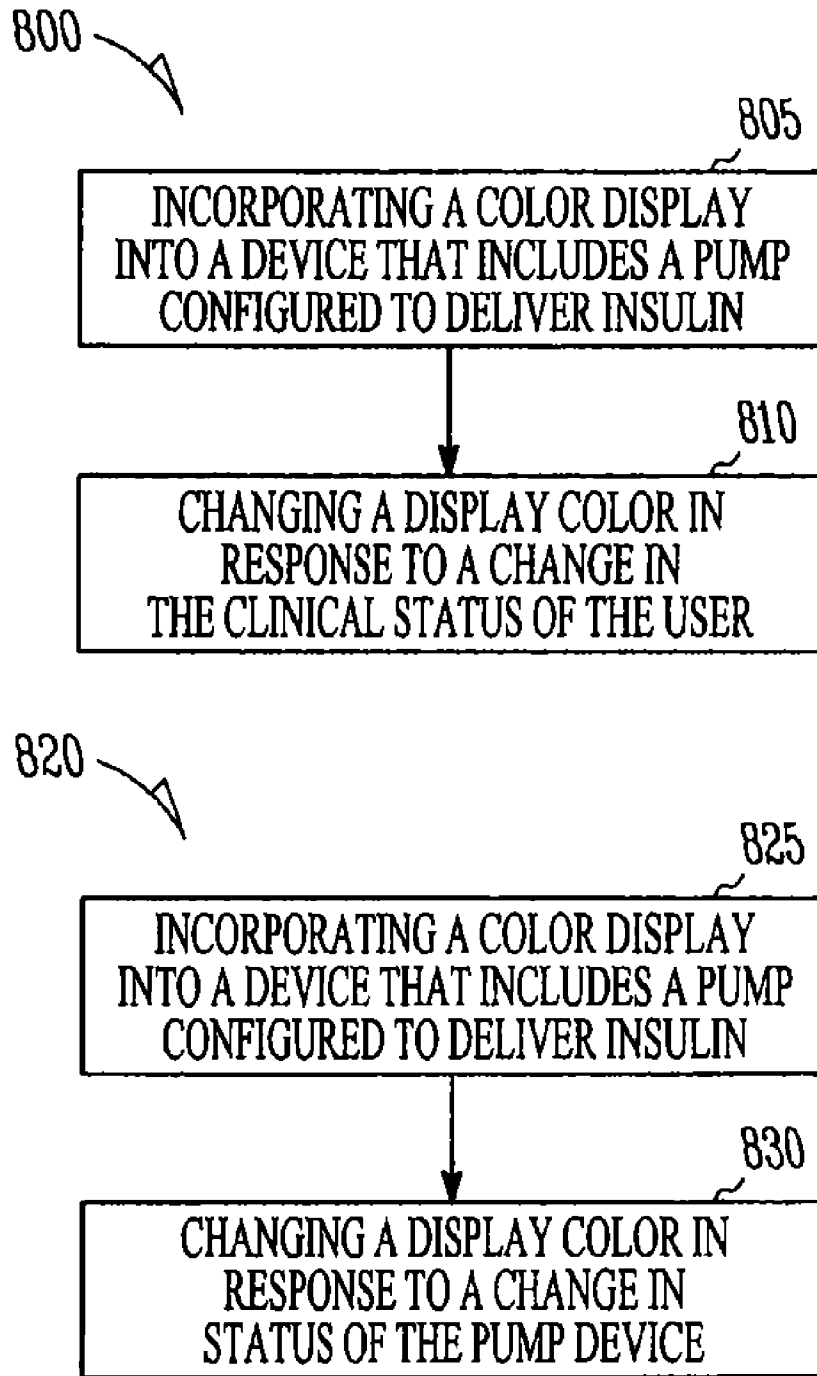

FIG. 8

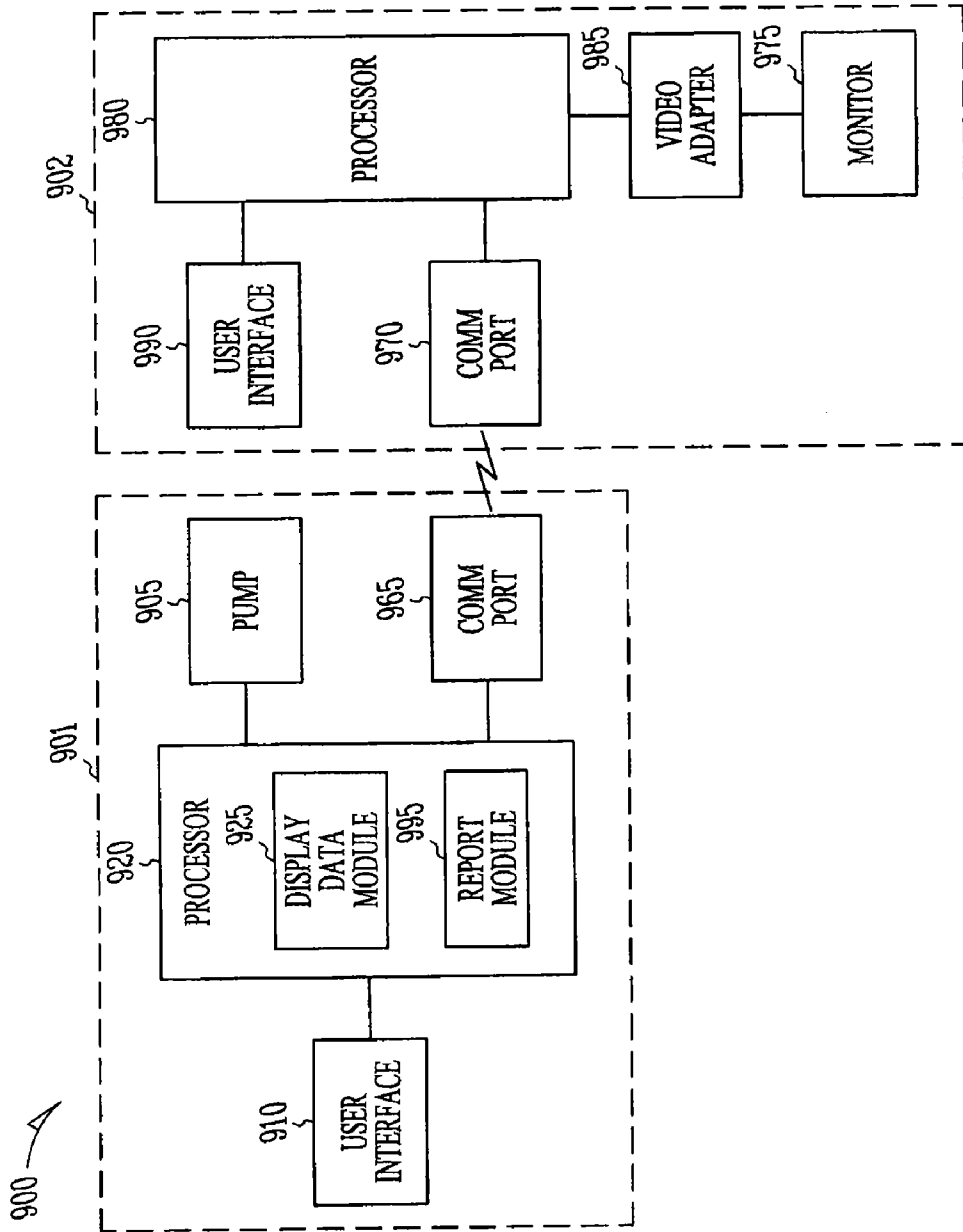

FIG. 9

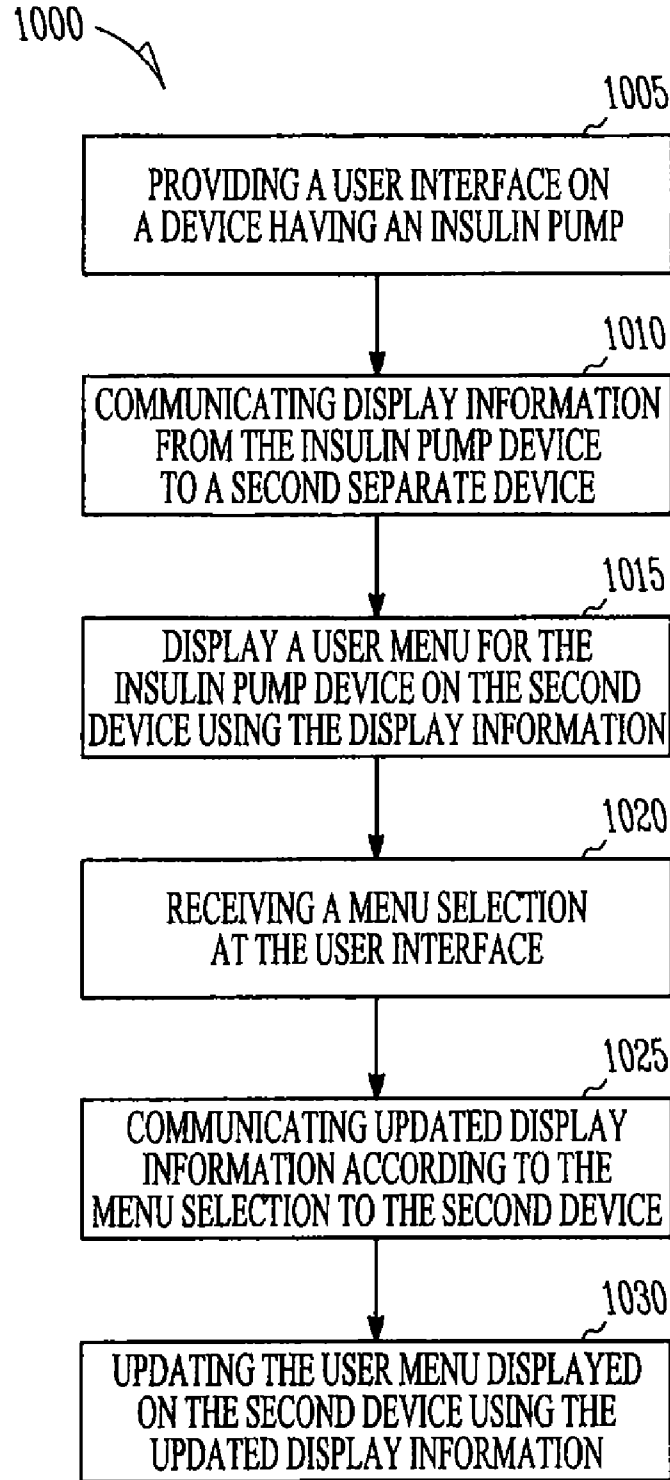

FIG. 10

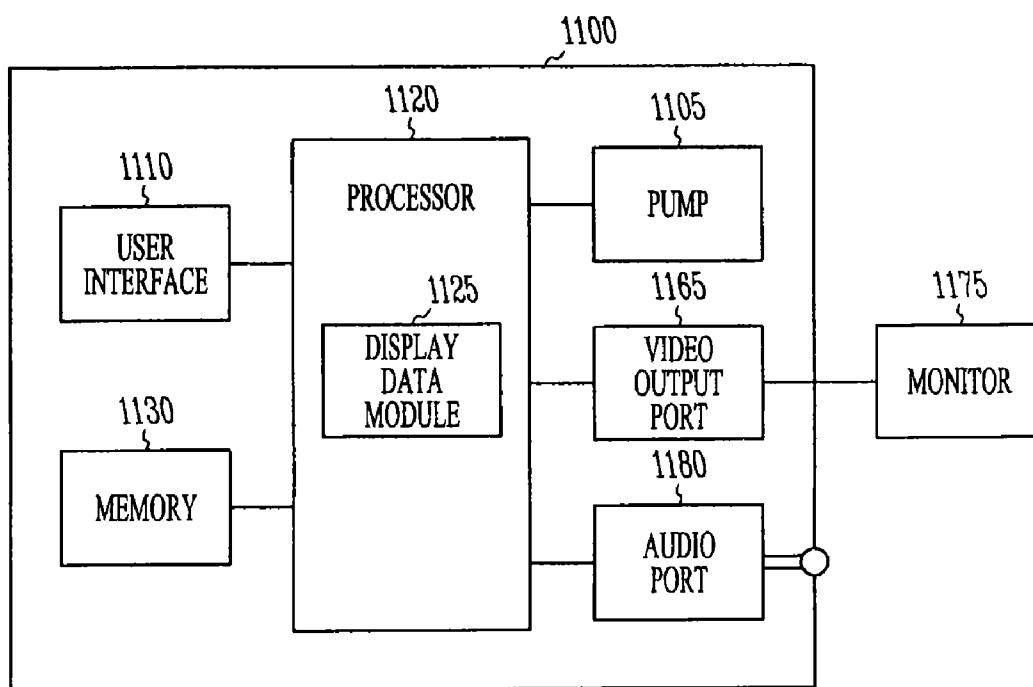

FIG. 11

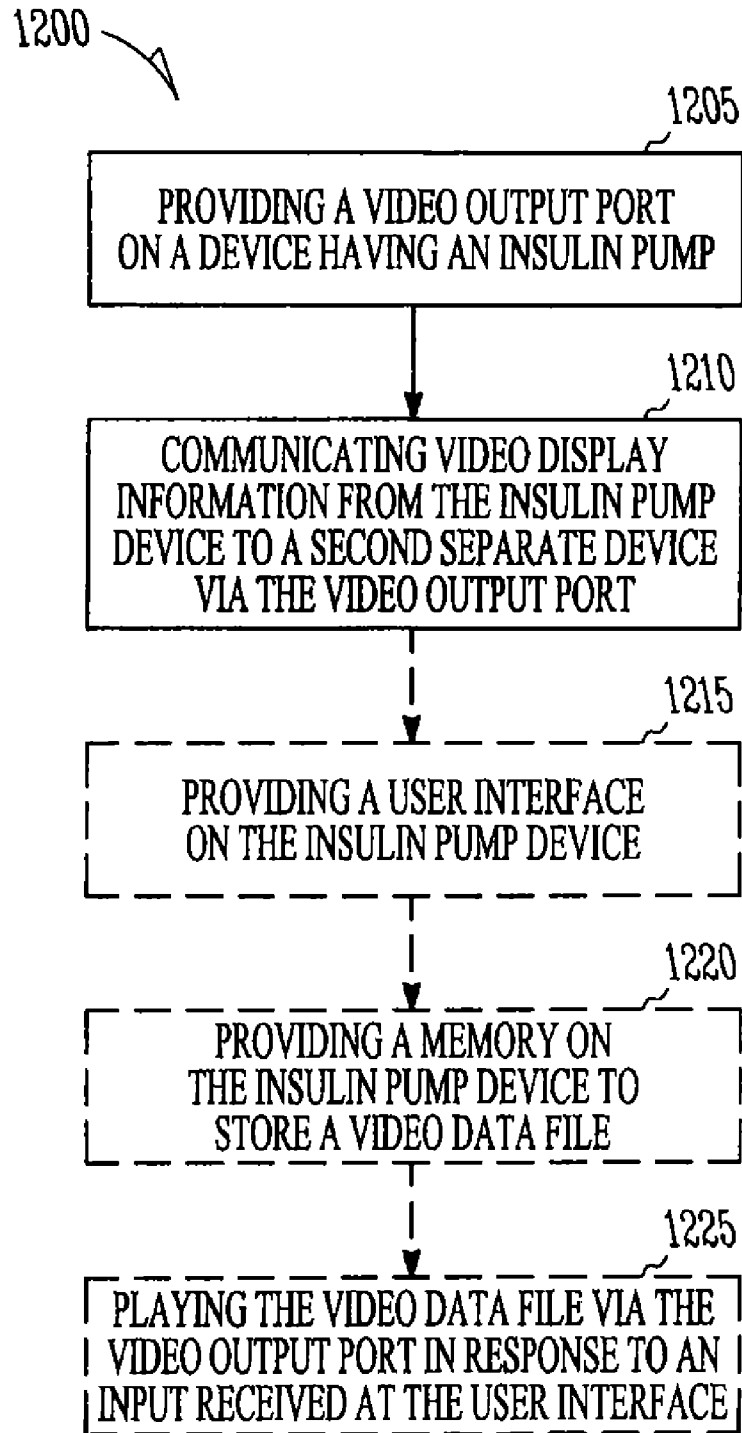

FIG. 12

DISPLAY FOR PUMP

RELATED APPLICATION

[0001] This application is a division of application Ser. No. 12/114,033 filed May 2, 2008, which is hereby fully incorporated herein by reference.

BACKGROUND

[0002] People who suffer from diabetes require insulin to keep their blood glucose level as close as possible to normal levels. It is essential for people with diabetes to manage their blood glucose level to within a normal range. Complications from diabetes can include heart disease (cardiovascular disease), blindness (retinopathy), nerve damage (neuropathy), and kidney damage (nephropathy). Insulin is a hormone that reduces the level of blood glucose in the body. Normally, insulin is produced by beta cells in the pancreas. In non-diabetic people, the beta cells release insulin to satisfy two types of insulin needs. The first type is a low-level of background insulin that is released throughout the day. The second type is a quick release of a higher-level of insulin in response to eating. Insulin therapy replaces or supplements insulin produced by the pancreas.

[0003] Conventional insulin therapy typically involves one or two injections a day. The low number of injections has the disadvantage of allowing larger variations in a person's insulin levels. Some people with diabetes manage their blood glucose level with multiple daily injections (MDI). MDI may involve more than three injections a day and four or more blood glucose tests a day. MDI offers better control than conventional therapy. However, insulin injections are inconvenient and require a diabetic person to track the insulin doses, the amount of carbohydrates eaten, and their blood glucose levels among other information critical to control.

[0004] It is important for a diabetic person to be treated with the proper amount of insulin. As discussed previously, high blood sugar can lead to serious complications. Conversely, a person with low blood sugar can develop hypoglycemia. Ideally, insulin therapy mimics the way the body works. An insulin pump is one way to mimic the body's insulin production. An insulin pump can provide a background or basal infusion of insulin throughout the day and provide a quick release or bolus of insulin when carbohydrates are eaten. If a person develops high blood sugar, a correction bolus can be delivered by the pump to correct it. While insulin pumps improve convenience and flexibility for a diabetic person, they can be sophisticated devices. Some insulin pumps can be difficult to program. It is desirable for an insulin pump to have features that make the pump more convenient or more effective for the patient to use.

Overview

[0005] This document discusses, among other things, devices and methods for assisting a diabetic person manage insulin therapy. A device example includes a pump configured to deliver insulin, a processor, and a user interface that includes a bistable display. A display element of the bistable display is placed in one of two stable orientations upon application of a biasing voltage. The display element stays in the stable orientation when the biasing voltage is removed. The processor includes a display module configured to display a non-blank reversion display screen on the bistable display when no input is received at the user interface after a specified

time duration, and to recurrently change the reversion display screen until input is received at the user interface.

[0006] A method example includes providing a bistable display on a device having an insulin pump, reverting the display to a non-blank reversion display screen when no input is received at a user interface after a specified time duration, and recurrently changing the reversion display screen until input is received at the user interface.

[0007] This section is intended to provide an overview of subject matter of the present patent application. It is not intended to provide an exclusive or exhaustive explanation of the invention. The detailed description is included to provide further information about the subject matter of the present patent application.

BRIEF DESCRIPTION OF THE DRAWINGS

[0008] FIGS. 1A and 1B illustrate portions of a device that includes an insulin pump.

[0009] FIG. 2 is a flow diagram of a method of presenting an insulin pump display to a user.

[0010] FIG. 3 is a block diagram of portions of an embodiment of an insulin pump device.

[0011] FIG. 4 is a block diagram of portions of another embodiment of an insulin pump device.

[0012] FIG. 5 shows an illustration of an example user interface with a display screen.

[0013] FIG. 6 is a flow diagram of another method of presenting an insulin pump display to a user.

[0014] FIG. 7 is a block diagram of portions of an embodiment of an insulin pump device.

[0015] FIG. 8 shows a flow diagram of another method of presenting an insulin pump display to a user.

[0016] FIG. 9 is a block diagram of portions of an embodiment of system for providing a display for an insulin pump device.

[0017] FIG. 10 is a flow diagram of another method of presenting a display for an insulin pump device.

[0018] FIG. 11 is a block diagram of portions of an embodiment of an insulin pump device having an alternative display.

[0019] FIG. 12 is a flow diagram of another method of presenting a display for an insulin pump device.

DETAILED DESCRIPTION

[0020] Insulin pump features may assist an insulin pump user in being more effective in treating their diabetes. FIGS. 1A and 1B illustrate portions of a device **100** that includes an insulin pump. The device **100** includes a cassette or cartridge of insulin. The cartridge is connectable to infusion tubing **140** connectable to a patient such as by a Luer lock **145** or infusion set **142**. The device **100** includes a display **102** and a user interface that may include the display **102** and include one or more keys **104**. Because proper use of an insulin pump often requires a user to go through a learning curve to properly treat their diabetes using the pump, it is desirable for a pump to provide assistance to the user in operating the pump, whether the user is a diabetic patient, a caregiver, or a clinician. Device displays are a useful way to provide information to the user.

Bistable Display

[0021] Ambulatory insulin pumps are typically battery powered. It is desirable to reduce power consumption in an ambulatory insulin pump device to extend the lifetime of the battery power source. Displays for the insulin pump devices

typically require power to maintain the display. For example, organic light emitting diodes (OLEDs) require constant power source to generate light. Liquid crystal displays (LCDs) typically require a refresh cycle to periodically update the display. LCDs may also require backlighting to illuminate pixels of the display. These examples require power to maintain the display even if the information on the display does not change.

[0022] In a bistable display, a display element (e.g., a pixel or a subpixel) is placed in one of two stable orientations upon application of a biasing voltage, and the display element stays in the stable orientation when the biasing voltage is removed. Thus, a bistable display mainly requires power only when changing the orientation of the display element, and requires little or no power to maintain the orientation.

[0023] An example of a bistable display is an electrophoretic display (EPD). In an EPD, particles in the display acquire charge from the biasing voltage. The polarity of the voltage determines whether the charged particle will have a black appearance (the first stable orientation) or white appearance (the second stable orientation). Ambient reflected light is used to read the display similar to the way ambient light is used to read a newspaper. EPDs are sometime referred to as electronic paper (e-paper) or electronic ink (e-ink).

[0024] Another example of a bistable display is an interferometric modulator (IMOD) display. In some embodiments of an interferometric modulator display, application of a voltage causes a display element to have black appearance (the first stable orientation), and application of a lower voltage causes the display to appear bright and colored (the second stable state). In a bichrome display, the display element is a pixel and the bias voltage is applied to a pixel. In a color display, a color pixel is comprised of a grid of display elements called sub-pixels and the bias voltage is applied to a sub-pixel. The sub-pixels exhibit different colors when the lower voltage is applied and produce the same color (e.g., black) when the bias voltage is applied. Together, the sub-pixels provide a full color display using spatial dithering. A description of IMOD displays is found in U.S. Pat. No. 7,042,643, "Interferometric Modulation of Radiation," filed Feb. 19, 2002, which is incorporated herein in its entirety.

[0025] Because a bistable display requires little or no power to maintain the display, the display will likely appear the same whether the insulin pump is working or the insulin pump has malfunctioned. This may make it difficult for an insulin pump user to notice when the device has malfunctioned.

[0026] FIG. 2 is a flow diagram of a method 200 of presenting an insulin pump display to a user. At block 205, a bistable display is provided on a device having an insulin pump. The display is bistable because a display element (e.g., a pixel or sub-pixel) may be placed in one of two stable orientations upon application of a biasing voltage, and the display element stays in the stable orientation when the biasing voltage is removed.

[0027] At block 210, the bistable display reverts to a non-blank reversion display screen when no input is received at a user interface of the insulin pump device after a specified time duration. For example, the reversion screen may be an icon from the manufacturer or a photo the user downloads into the insulin pump device. However, because of the nature of a bistable display, a user would not be able to notice from a simple reversion screen whether the device is still functioning properly.

[0028] At block 215, the reversion display screen is recurrently changed until input is received at the user interface. In some embodiments, recurrently changing the reversion display screen may include recurrently changing from one of a plurality of reversion display screens to another of the plurality of display screens. In some embodiments, recurrently changing the reversion display screen may include recurrently producing an animated effect on a single reversion display screen. In some embodiments, recurrently changing the reversion display screen may include switching among several display screens to create an animated effect, such as sequentially displaying animation frames to produce an animated effect. Use of reversion screens may assist a user in operating their insulin pump device.

[0029] FIG. 3 is a block diagram of portions of an embodiment of an insulin pump device 300. The insulin pump device 300 includes a pump 305 configured to deliver insulin and a user interface 310. The pump 305 may be a positive displacement pump. Descriptions of an example of a medication pump to deliver insulin are found in Vilks et al., "Cartridge and Rod for Axially Loading a Medication Pump," U.S. patent application No. 7,033,338, filed Feb. 28, 2002, which is incorporated herein by reference in its entirety. The pump 305 may drive a plunger in a removable insulin cartridge to deliver the insulin.

[0030] The user interface 310 includes a bistable display 315. In some embodiments, the bistable display 315 includes an interferometric modulation display. In some embodiments, the bistable display 315 includes an electrophoretic display. In some embodiments, the bistable display 315 includes an EPD. The substrate for the EPD may be made of flexible plastic. This provides a robust and thin display for the insulin pump device 300.

[0031] The insulin pump device 300 also includes a processor 320. The processor 320 may be a microprocessor, digital signal processor (DSP), or other type of processor. The processor 320 is configured to perform or execute a function or functions. Such functions correspond to modules to provide features integral to the first device. Modules may be software, hardware, firmware or any combination thereof. Multiple functions may be performed in one or more modules. In some embodiments, software or firmware is provided on a computer readable medium. The computer readable medium includes instructions therein, which when processed (such as by the processor 320 for example) results in a device performing the functions described herein. Examples of a computer readable medium include a compact disc (CD), memory stick, or remote storage accessible via a communication network such as the internet or a cell phone network.

[0032] The processor 320 is communicatively coupled to the pump 305 and the user interface 310. The communicative coupling allows the processor 320 to exchange electrical signals with the pump 305 and the user interface 310 even though intervening circuitry may be present. The processor 320 includes a display module 325 configured to display a non-blank reversion display screen on the bistable display 315 when no input is received at the user interface 310 after a specified time duration, and to recurrently change the reversion display screen until input is received at the user interface.

[0033] In some embodiments, the display module 325 is configured to produce an animated effect on the reversion display screen. For example, the animated effect may be a moving icon. The display module 325 recurrently produces the animated effect on the reversion display screen until input

is received at the user interface **310**. At which point the display module **325** may change from the reversion screen display to a home menu display.

[0034] In an illustrative example, the moving icon may be a clock and the animated effect may be moving hands of the clock. The display module **325** periodically produces the animated effect by moving the hands of the clock to display time according to a timer of the processor. In some embodiments, the display module **325** is configured to display time on the reversion display screen by displaying numbers on the display screen and updating the numbers according to the time.

[0035] According to some embodiments, the insulin pump device **300** includes a memory **330** communicatively coupled to the processor **320**. The memory **330** stores a plurality of reversion display screens, and the display module **325** is configured to display one of the plurality of reversion display screens when no input is received at the user interface after a specified time duration, and to recurrently change the reversion display screen from one of the plurality of reversion display screens to another of the plurality of reversion display screens while no input is received at the user interface **310**. The reversion display screen would change after a time duration, such as every few seconds for example.

[0036] In some embodiments, the display module **325** is configured to change the reversion display screen in response to input received via the user interface. For example, as a test to verify the insulin pump device **300** is working properly, the reversion display screen would change when the user presses a specified user interface key or button. In another example, the user may use the user interface **310** to advance through several reversion display screen options and indicate a desired display screen. In certain embodiments, the memory **330** stores an indication that a reversion display screen is selected by a user. The display module **325** only displays one or more reversion screens selected by the user. In certain embodiments, one or more reversion screens are images downloaded by the user, such as photos for example. The display module **325** may display the images in a slide-show fashion.

[0037] Various events may cause the display module **325** to change the bistable display **315** from a reversion screen. In some embodiments, the display module **325** changes the bistable display **315** from the reversion display screen to a home menu when input is received at the user interface **310**. In some embodiments, the display module **325** changes the bistable display **315** from the reversion display screen in response to a change in status of the insulin pump device **300**. For example, the change in status may be related to a problem of the insulin pump device **300**, such as an insulin cartridge containing less than a threshold level of insulin, a device battery having a capacity less than a threshold battery capacity value, or an indication that the insulin pump device is not operating correctly. The display module **325** may change to an alarm display screen to indicate a problem to the user, may change to a debug display screen to help the user determine the problem, or may display both an alarm display screen and a debug display screen.

[0038] In some embodiments, the display module **325** changes the reversion display screen in response to a detected change in a clinical status of a user. The change in clinical status may include at least one of a recent blood glucose reading being higher than a first threshold blood glucose value, a recent blood glucose reading being lower than the same threshold blood glucose value or a second threshold

blood glucose value, the user exercising within a specified time period, the user eating within a specified time period, the user not eating within a specified time period, or the user having active insulin in their body. The display module **325** may change to an alarm display screen to indicate the change in clinical status to the user.

Custom Display Menus

[0039] Insulin pumps may be able to provide a variety of therapies and diagnostics for the user. Accessing the functions of the device may include navigating through several layers of device menus. It would be helpful to the user if the display menus are customized for the user. The menus may be automatically customized according to which functions are used most often, according to which functions are more appropriate for the users clinical status, or the menus may be manually customized by the user directly.

[0040] FIG. 4 is a block diagram of portions of an embodiment of an insulin pump device **400**. The insulin pump device **400** includes a pump **405** configured to deliver insulin and a user interface **410** that includes a display **415**. In some embodiments, the display **415** is a bistable display. The insulin pump device **400** also includes a processor **420** communicatively coupled to the pump **405** and the user interface **410**. The processor **420** includes a menu display module **425**. The menu display module **425** presents one of a plurality of device menus on the display **415**.

[0041] FIG. 5 shows an illustration of an example user interface **510** with a display screen **515**. The user interface **510** includes a keypad **540** including function keys **542** and scroll keys **544** or up/down keys. The display screen **515** shows an example display menu having menu items. The user interface **510** receives a selection of a menu item included in a display menu. Selecting a menu item causes the processor to perform an action, such as indicating a status of the insulin pump device, modifying an operation parameter, or initiating a device task.

[0042] The example display menu shown has a top portion **546** and a bottom portion **548**. The top portion **546** may show a display banner **550** identifying the pump as "Mary's Pump". The display banner **550** may be customized by the user via the keypad **540**. The example display menu is one shown during active delivery of basal insulin. The display menu indicates basal insulin is being delivered at a rate of 1.15 units/hour according to a first basal schedule. The top portion **546** may present the name **552** of the active function and details of the function performed.

[0043] The bottom portion indicates the current function of the keys **542**, **544**. In the display shown, the pressing the left function key suspends the basal delivery. If delivery is suspended, the function of the left function key may change to activating the delivery. The right function key advances the display screen to a different display menu. The up/down keys retain the up/down function. For example, the scroll keys **544** may be used to highlight the name **552** of the active function in order to change from the first basal schedule.

[0044] The example display menu also shows a first icon **554** and a bar **556** to show the amount of insulin remaining in the insulin cartridge, and a second icon **558** and a bar **560** to indicate the remaining battery life. The example display menu also shows a third icon **562** to identify the display menu as the home menu or home page for the user.

[0045] Returning to FIG. 4, it was noted that the menu display module **425** presents one of a plurality of device

menus on the display **415**. The menu display module **425** arranges the device menus into an order for presentation according to user preference information. In some embodiments, the user preference information includes the frequency that certain menus are used. The menu display module **425** tracks device menu selections made via the user interface **410**. The menu display module **425** then arranges the device menus into a presentation order according to a frequency with which device menus are used. For example, if the user frequently accesses the basal delivery display menu, the menu display module **425** moves the basal delivery display menu closer to the beginning of the order with which device menus are displayed.

[0046] According to some embodiments, the user preference information includes information regarding the clinical status of the user. The information may be entered into a memory **430** of the device via the user interface **410** or may be downloaded into the memory **430** via a communication port. The processor **420** receives the clinical status information and the menu display module **425** arranges the device menus into the presentation order according to the clinical status information.

[0047] For example, the clinical status information may indicate that the user has delayed gastric emptying. A user with delayed gastric emptying may use an extended or combination bolus of insulin. Descriptions of insulin pump devices that provide extended and combination boluses are found in Blomquist, U.S. patent application Ser. No. 11/679,712, "Carbohydrate Ratio Test Using Frequent Blood Glucose Input," filed Feb. 27, 2007, which is incorporated herein by reference in its entirety. The menu display module **425** may make it more convenient for the user to access the display menu used to program and initiate an extended and/or combination bolus (e.g., the extended bolus menu may be presented before the standard bolus display menu).

[0048] In another example, the clinical status information may include an indication that the user has a high or low blood glucose reading. The menu display module **425** may make it more convenient (e.g., displayed sooner in a hierarchy) for the user to access a display menu that is used when measuring blood glucose. The menu display module **425** may also make it more convenient for the user to access the blood glucose measurement display menu if the user is performing basal rate testing. Descriptions of devices that automatically perform basal rate testing are found in Blomquist, U.S. patent application Ser. No. 11/685,617, "Basal Rate Test Using Frequent Blood Glucose Input," filed Mar. 13, 2007, which is incorporated herein by reference in its entirety.

[0049] According to some embodiments, the processor **420** determines information regarding eating times of the user. The processor **420** may determine the information by receiving the information through a communication port or via a user interface. The processor **420** may determine the information by deducing the information regarding eating times from other programmed parameters, such as programmed meal boluses or programmed missed meal bolus alarms. In some embodiments the processor **420** may determine the information by learning the eating times of the user, such as by tracking the times a meal bolus is initiated for example.

[0050] The menu display module **425** arranges the device menus into the presentation order according to the eating times of the user. For example, based on the information, the menu display module **425** may arrange the display menus in anticipation of the user initiating a post-prandial blood glu-

cose test, and make the blood glucose measurement display menu more convenient for the user to access.

[0051] According to some embodiments, the processor **420** includes a timing module **435**. The menu display module **425** arranges the device menus into the presentation order according to a time of day. For example, the menu display module **425** may make it more convenient for the user to access a display menu used to program and/or initiate a meal or correction bolus based on time the user typically exercises or eats. In another example, if the user checks their blood glucose at a specific time of day, the menu display module **425** may make the blood glucose measurement display menu more convenient for the user to access at those times. In still another example, the user may disconnect the pump or change the insulin cartridge at specific times of day. The menu display module **425** may make the related display menus easier for the user to access at those times.

[0052] In some embodiments, the user enters the user preference information via the user interface. For example, the user enters an indication of which display menu she wishes to display as the home display menu. The processor **420** receives the user preference information and the menu display module **425** arranges the device menus into the presentation order according to the received user preference information.

[0053] The menu items included in a home menu are a subset of all available menu items. In some embodiments, the menu display module includes menu items in the home menu according to the user preference information. For example, the user may provide, via the user interface **410**, an indication that the battery icon of FIG. 5 should be placed in the home menu. In certain embodiments, the processor **420** includes the timing module **435** and the user preference information includes a display reversion time duration. The menu display module **425** reverts from a displayed menu to the home menu when no displayed menu items are selected during the display reversion time duration.

[0054] In some embodiments, the menu display module **425** tracks device menu selections made via the user interface. The menu display module **425** includes menu items in the device home menu according to a frequency with which menu items are used. For example, if the user frequently checks how much insulin is remaining in the insulin cartridge, the menu display module **425** adds the insulin remaining icon to the home menu.

[0055] According to some embodiments, the insulin pump device **400** includes a memory **430** communicatively coupled to the processor to store a database of food options in association with a known amount of nutrient content. Nutrient content includes one or more of the amount of carbohydrates, fat, protein, or fiber in an amount of a type of food. The menu display module **425** displays food options in one or more display menus. The user indicates the food she is going to eat and the processor **420** may use the nutrient content for the indicated food option to determine an amount of insulin in a meal bolus or to determine a type of meal bolus for the user.

[0056] In some embodiments, the menu display module **425** is configured to track selections from the food database made by the user. The menu display module **425** may then arrange a viewing order of entries in the food database according to a frequency with which entries are selected. For example, if the user often selects pizza for lunch, the menu display module **425** may select that food option first when the food database menu is accessed at lunchtime.

[0057] In some embodiments, the user interface 410 includes a programmable tactile switch or button (e.g., tactile switch 564 in FIG. 5). The processor 420 is configured to initiate an action upon activation of the tactile switch. The processor action is specified in the user preference information. Thus, the tactile switch may be a generic switch or button until it is programmed by the user. For example, the tactile switch may be programmed to initiate a type of insulin bolus, to bring a specific display menu, or to activate a type of alarm provided by the insulin pump device 400.

[0058] FIG. 6 is a flow diagram of a method 600 of presenting an insulin pump display to a user. At block 605, a user interface is provided on a device having an insulin pump. The user interface includes a display. At block 610, user preference information is received into the device via the user interface. At block 615, a viewing order of a plurality of displayed device menus is arranged according to the user preference information.

Color Display

[0059] Information presented on a display is not of much use to the user if the user does not notice the information. Color on a display can be used to bring a user's attention to a change in status of the device or a detected change in status of the patient.

[0060] FIG. 7 is a block diagram of portions of an embodiment of an insulin pump device 700. The insulin pump device 700 includes a pump 705 configured to deliver insulin and a color display 715. In some embodiments, the color display 715 includes a color bistable display. The insulin pump device 700 also includes a processor 720 that comprises a display module 725 to display information related to clinical status of a user using a color indication and to change the color indication in response to a change in clinical status of the user.

[0061] Examples of a change in clinical status of the user include, among other things, a recent blood glucose reading being higher than a first threshold blood glucose value, a recent blood glucose reading being lower than the same threshold blood glucose value or a second threshold blood glucose value, the user exercising within a specified time period, the user eating within a specified time period, the user not eating within a specified time period, and the user having active insulin in their body.

[0062] Examples of change in a color indication used in the display 715 include, among other things, a change in a display background color, a change in a display backlight color, a change in a text color, and a color flashing indicator. The display module 725 changes the color indication when the clinical status changes. For example, the display module 725 may use a first display color when the user selects an insulin bolus display menu and there is no active insulin in the user's body, and uses a second display color when the user selects an insulin bolus display menu and there is active insulin in the user's body. In another example, the display module 725 may flash the insulin bolus display menu with the first or second display color when there is active insulin in the user's body.

[0063] In another embodiment, the change in a color indication is a gradual change. For example, the display module 725 may gradually change the color indication according to an amount of insulin that is active in the user, such as by gradually fading from the second display color to the first display color as the amount of active insulin decreases.

[0064] According to some embodiments, the display module 725 generates a device report on the color display 715.

The processor 720 stores events in a memory integral to or communicatively coupled to the processor 720. The events may include historical insulin delivery information, recorded use parameters, and changes in the clinical status of the user. The display module 725 displays the device report and uses a color indication to show a change in clinical status.

[0065] In some embodiments, the insulin pump device includes a communication port 765 communicatively coupled to the processor 720. In some embodiments, the communication port 765 is a wireless port, such as an infrared (IR) port or a radio frequency (RF) port for example. In some embodiments, the communication port 765 is a wired port, such as a serial port for example. The processor 720 communicates the generated device report to a second separate device via the communication port, such as for printing of the device report or for displaying the device report for example.

[0066] FIG. 8 shows a flow diagram of a method 800 of presenting an insulin pump display to a user. At block 805, a color display is incorporated into a device that includes a pump configured to deliver insulin. At block 810, a display color is changed in response to a change in clinical status of the user.

[0067] Returning to FIG. 7, according to some embodiments, the display module 725 is configured to change the color indication in response to a change in status of the insulin pump device. Examples of a change in status of the insulin pump device include, among other things, an insulin cartridge containing less than a threshold level of insulin, a device battery having a capacity less than a threshold battery capacity value, or an indication that the insulin pump device (e.g., the pump 705 itself) has stopped operating.

[0068] FIG. 8 also shows a flow diagram of a second method 820 of providing an insulin pump display to a user. At block 825, a color display is incorporated into a device that includes a pump configured to deliver insulin. In some embodiments, a color bistable display is incorporated into the device. At block 830, a display color is changed in response to a change in status of the insulin pump device.

Alternative Remote Display

[0069] Insulin pumps continue to decrease in size as technology advances. However, bigger displays are sometimes desirable for training on the devices or if the user has impaired vision.

[0070] FIG. 9 is a block diagram of portions of an embodiment of system 900 for providing a display for an insulin pump device. The system 900 comprises an insulin pump device 901 and a display device 902. The insulin pump device 901 includes a pump 905 configured to deliver insulin, a user interface 910, a communication port 965, and a first processor 920 communicatively coupled to the pump 905, the user interface 910, and the communication port 965.

[0071] The display device 902 includes a communication port 970, a monitor 975, and a second processor 980 communicatively coupled to the communication port 970 and the monitor 975. The first processor 920 includes a display data module 925 that communicates display information from the insulin pump device to the display device 902 via the communication ports 965, 970.

[0072] In some embodiments, the communication ports 965, 970 are wireless ports, such as an IR ports or RF ports for example. The insulin pump device 901 and the display device may communicate using a wireless protocol such as Bluetooth protocol, the WiFi protocol, or the infrared data (IrDA)

protocol. In some embodiments, the communication ports **965** are wired ports, such as serial ports for example. The insulin pump device **901** and the display device may communicate using the universal serial bus (USB) protocol.

[0073] Input signals received at the user interface **910** change operation of the insulin pump device **901**. These changes are reflected on the monitor **975** of the display device **902**. The data display module **925** converts input received via the user interface **910** into changes to a display, and communicates updated display information according to the received input to the display device **902**. The second processor receives the display information via the communication port **970** and displays a user menu for the insulin pump device **901** on the monitor **975**.

[0074] Examples of display information communicated by the display data module **925** to the display device **902** include, among other things, an indication of status of the insulin pump device, a prompt to initiate a task by the insulin pump device, or an operation parameter of the insulin pump device. In some embodiments, the display data module **925** communicates, for display on the display device **902**, instructions for using the insulin pump device **901**. This is useful for training a new user to operate the insulin pump device **901**.

[0075] The monitor **975** may be a larger display than is available for the insulin pump device **901**, and the second processor **980** may display an enlarged version of the user menu for the insulin pump device **901** on the monitor **975**. This allows the user to easily see how the input into the user interface **910** has effected operation of the insulin pump device **901**. In some embodiments, the monitor **975** is a video monitor and the display device **902** includes a video adapter **985** communicatively coupled to the second processor **980** and the video monitor to convert the received display information to a video format for display on the video monitor.

[0076] According to some embodiments, the display device **902** includes a second user interface **990** communicatively coupled to the second processor **980**. The second processor **980** manipulates the user menu for the insulin pump device **901** on the monitor **975** according to input received via the second user interface **990**. Thus, the user menu displayed on the display device **902** may be changed according to input received via the second user interface **990**. For example, the second user interface **990** allows the second processor to change a contrast of the user menu for the insulin pump device displayed on the monitor, a size of the user menu for the insulin pump device displayed on the monitor, or a color used in the displaying the user menu for the insulin pump device on the monitor.

[0077] According to some embodiments, the first processor **920** includes a report module **995** to generate a device report. As described previously, the device report may include historical insulin delivery information, recorded use parameters, and changes in the clinical status of the user. The display data module **925** communicates the device report to the display device **902** for display.

[0078] FIG. **10** is a flow diagram of a method **1000** of presenting a display for an insulin pump device. At block **1005**, a user interface is provided on a device having an insulin pump. At block **1010**, display information is communicated from the insulin pump device to a second separate device. At block **1015**, displaying a user menu for the insulin pump device is displayed on the second device using the display information. In some embodiments, the display information is converted to a video format at the second device and

displayed on a video monitor. At block **1020**, a menu selection is received at the user interface of the insulin pump. The menu selection is a menu item displayed on second device. The menu selection may be to change an operating parameter, initiate insulin therapy, display a device status, or run a device diagnostic for example. At block **1025**, updated display information is communicated to the second device according to the menu selection.

[0079] FIG. **11** is a block diagram of portions of an embodiment of an insulin pump device **1100** having an alternative display. The insulin pump device **1100** includes a pump **1105** configured to deliver insulin, a video output port **1165**, and a processor **1120** communicatively coupled to the pump **1105** and the video output port **1165**. The processor **1120** includes a display data module **1125** that communicates video display information via the video output port to a second separate device, such as a video monitor **1175** for example. The insulin pump device **100** is connected to the monitor **1175** via the video output port **1165**.

[0080] In some embodiments, the video output port **1165** is an analog video output. The display data module **1125** provides the video display information in an analog video format at the video output port **1165**. Examples of analog video formats provide by the display data module **1125** include, among other things, composite video, S video, component video, and VGA. In some embodiments, the video output port **1165** is a digital video output. The display data module **1125** provides the video display information in a digital format at the video output port **1165**. Examples of digital video formats provide by the display data module **1125** include, among other things, High Definition Multimedia Interface (HDMI) and Digital Visual Interface (DVI).

[0081] In some embodiments, the insulin pump device **1100** includes a user interface **1110**. The display data module **1125** converts input received via the user interface **1110** into changes to a display and communicates updated video display information according to the received input via the video output port. In this way, the monitor **1175** acts as a display for the insulin pump device **1100**. The user interface **1110** may include a display screen on the insulin pump device **1100**. The display data module **1125** may provide updated data to both the user interface display and the monitor **1175**. The monitor **1175** may thereby function as an enlarged version of the device display screen.

[0082] In some embodiments, the insulin pump device **1100** includes a memory **1130**. The memory **1130** stores one or more files containing video data. The display data module **1125** plays a video data file via the video output port **1165**. The video data file may include training material, and the video data file provides a video tutorial to the user on the monitor **1175** when played. In some embodiments, the insulin pump device **1100** plays the video data file in response to an input received at the user interface **1110**, such as an indication of menu selection for example.

[0083] In some embodiments, the insulin pump device **1100** includes an audio port **1180**. The memory **1130** may store one or more files containing audio data. The display data module **1125** is configured to play the audio data file via the audio port **1180** in association with playing the video data file. In some embodiments, if the format of the file allows audio and video to be combined, the audio and video files may be provided by a single output port. The audio file may indicate a pump-related alarm or alert, or the audio file may accompany the training video.

[0084] FIG. 12 is a flow diagram of another method 1200 of presenting a display for an insulin pump device. At block 1205, a video output port is provided on a device having an insulin pump. At block 1210, video display information is communicated from the insulin pump device to a second separate device via the video output port. The second device may be a monitor or a television depending on the video format. Thus, the pump is a video driver for the second device.

[0085] As further shown in FIG. 12, in some embodiments the method 1200 includes, at block 1215, providing a user interface on the insulin pump device. At block 1220, providing a memory is provided on the insulin pump device to store one or more video data files. At block 1225, the video data file is played via the video output port in response to an input received at the user interface.

[0086] The above detailed description includes references to the accompanying drawings, which form a part of the detailed description. The drawings show, by way of illustration, specific embodiments in which the invention can be practiced. These embodiments are also referred to herein as “examples.” All publications, patents, and patent documents referred to in this document are incorporated by reference herein in their entirety, as though individually incorporated by reference. In the event of inconsistent usages between this document and those documents so incorporated by reference, the usage in the incorporated reference(s) should be considered supplementary to that of this document; for irreconcilable inconsistencies, the usage in this document controls.

[0087] In this document, the terms “a” or “an” are used, as is common in patent documents, to include one or more than one, independent of any other instances or usages of “at least one” or “one or more.” In this document, the term “or” is used to refer to a nonexclusive or, such that “A or B” includes “A but not B,” “B but not A,” and “A and B,” unless otherwise indicated. In the appended claims, the terms “including” and “in which” are used as the plain-English equivalents of the respective terms “comprising” and “wherein.” Also, in the following claims, the terms “including” and “comprising” are open-ended, that is, a system, device, article, or process that includes elements in addition to those listed after such a term in a claim are still deemed to fall within the scope of that claim. Moreover, in the following claims, the terms “first,” “second,” and “third,” etc. are used merely as labels, and are not intended to impose numerical requirements on their objects.

[0088] Method examples described herein can be machine or computer-implemented at least in part. Some examples can include a computer-readable medium or machine-readable medium encoded with instructions operable to configure an electronic device to perform methods as described in the above examples. An implementation of such methods can include code, such as microcode, assembly language code, a higher-level language code, or the like. Such code can include computer readable instructions for performing various methods. The code may form portions of computer program products. Further, the code may be tangibly stored on one or more volatile or non-volatile computer-readable media during execution or at other times. These computer-readable media may include, but are not limited to, hard disks, removable magnetic disks, removable optical disks (e.g., compact disks and digital video disks), magnetic cassettes, memory cards or sticks, random access memories (RAM's), read only memories (ROM's), and the like.

[0089] The above description is intended to be illustrative, and not restrictive. For example, the above-described examples (or one or more aspects thereof) may be used in combination with each other. Other embodiments can be used, such as by one of ordinary skill in the art upon reviewing the above description. The Abstract is provided to comply with 37 CFR §1.72(b), to allow the reader to quickly ascertain the nature of the technical disclosure. It is submitted with the understanding that it will not be used to interpret or limit the scope or meaning of the claims. Also, in the above Detailed Description, various features may be grouped together to streamline the disclosure. This should not be interpreted as intending that an unclaimed disclosed feature is essential to any claim. Rather, inventive subject matter may lie in less than all features of a particular disclosed embodiment. Thus, the following claims are hereby incorporated into the Detailed Description, with each claim standing on its own as a separate embodiment. The scope of the invention should be determined with reference to the appended claims, along with the full scope of equivalents to which such claims are entitled.

What is claimed is:

1. A system comprising a pump device and a display device, wherein the pump device includes:
 - a pump;
 - a user interface;
 - a communication port; and
 - a processor communicatively coupled to the pump, the user interface, and the communication port, wherein the processor includes a display data module configured to:
 - communicate display information from the pump device to the display device via the communication port;
 - convert input received via the user interface into changes to a display; and
 - communicate updated display information according to the received input to the display device, and
 wherein the display device includes:
 - a communication port;
 - a monitor; and
 - a second processor communicatively coupled to the communication port and the monitor, wherein the second processor is configured to receive display information via the communication port and to display a user menu for the pump device on the monitor.
2. The system of claim 1, wherein the monitor is a video monitor, and wherein the display device includes a video adapter communicatively coupled to the second processor and the video monitor to convert the received display information to a video format for display on the video monitor.
3. The system of claim 1, wherein the display data module is configured to communicate, for display on the display device, at least one of an indication of status of the pump device, a prompt to initiate a task by the insulin pump device, or an operation parameter of the insulin pump device.
4. The system of claim 1, wherein the display data module is configured to communicate, for display on the display device, instructions for using the pump device.
5. The system of claim 1, wherein the processor includes a report module configured to generate a device report, and wherein the display data module is configured to communicate the device report to the display device for display.
6. The system of claim 1, including a second user interface communicatively coupled to the second processor, wherein

the second processor is configured to manipulate the user menu for the pump device on the monitor according to input received via the user interface.

7. The system of claim 6, wherein the second processor is configured to change, according to input received via the second user interface, at least one of:

a contrast of the user menu for the pump device displayed on the monitor,

a size of the user menu for the pump device displayed on the monitor, or

a color used in the displaying the user menu for the pump device on the monitor.

8. The system of claim 1, wherein the second processor is configured to display an enlarged version of the user menu for the pump device on the monitor.

9. The system of claim 1, wherein the display information includes a report generated by the pump device, and wherein the second processor is configured to display the report on the monitor.

* * * * *