

(19) World Intellectual Property Organization
International Bureau



(43) International Publication Date
21 March 2002 (21.03.2002)

PCT

(10) International Publication Number
WO 02/22265 A1

- (51) International Patent Classification⁷: **B01L 3/00** // C12Q 1/68
- (74) Agent: **BOULT WADE TENNANT**; Verulam Gardens, 70 Gray's Inn Road, London WC1X 8BT (GB).
- (21) International Application Number: PCT/GB01/04145
- (81) Designated States (*national*): AE, AG, AL, AM, AT, AU, AZ, BA, BB, BG, BR, BY, BZ, CA, CH, CN, CO, CR, CU, CZ, DE, DK, DM, DZ, EC, EE, ES, FI, GB, GD, GE, GH, GM, HR, HU, ID, IL, IN, IS, JP, KE, KG, KP, KR, KZ, LC, LK, LR, LS, LT, LU, LV, MA, MD, MG, MK, MN, MW, MX, MZ, NO, NZ, PH, PL, PT, RO, RU, SD, SE, SG, SI, SK, SL, TJ, TM, TR, TT, TZ, UA, UG, US, UZ, VN, YU, ZA, ZW.
- (22) International Filing Date:
17 September 2001 (17.09.2001)
- (25) Filing Language: English
- (26) Publication Language: English
- (30) Priority Data:
0022754.6 15 September 2000 (15.09.2000) GB
- (84) Designated States (*regional*): ARIPO patent (GH, GM, KE, LS, MW, MZ, SD, SL, SZ, TZ, UG, ZW), Eurasian patent (AM, AZ, BY, KG, KZ, MD, RU, TJ, TM), European patent (AT, BE, CH, CY, DE, DK, ES, FI, FR, GB, GR, IE, IT, LU, MC, NL, PT, SE, TR), OAPI patent (BF, BJ, CF, CG, CI, CM, GA, GN, GQ, GW, ML, MR, NE, SN, TD, TG).
- (71) Applicant (*for all designated States except US*): **NORCHIP A/S** [NO/NO]; Industriveien 8, N-3490 Klokkekarstua (NO).
- Published:**
— with international search report
— before the expiration of the time limit for amending the claims and to be republished in the event of receipt of amendments
- (71) Applicant (*for MG only*): **ALLARD, Susan, Joyce** [GB/GB]; Verulam Gardens, 70 Gray's Inn Road, London WC1X 8BT (GB).
- (72) Inventor; and
- (75) Inventor/Applicant (*for US only*): **KARLSEN, Frank** [NO/NO]; Hovkastet 2, N-3490 Klokkekarstua (NO).
- For two-letter codes and other abbreviations, refer to the "Guidance Notes on Codes and Abbreviations" appearing at the beginning of each regular issue of the PCT Gazette.*

(54) Title: MICROFABRICATED REACTION CHAMBER SYSTEM

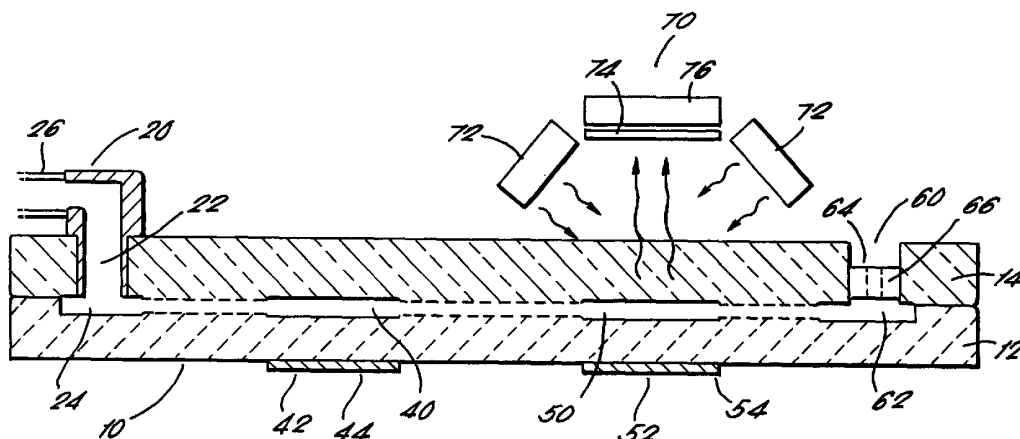

(57) Abstract: A microfabricated reaction chamber system for carrying out a nucleic acid sequence amplification and detection process on a nucleic acid sample, the process comprising at least first and second process steps using first and second reagents, the device comprising: an inlet port; a first reaction chamber in communication with the inlet port, for carrying out the first process step; a second reaction chamber in communication with the first reaction chamber, for carrying out the second process step; and an outlet port in communication with the second reaction chamber.

WO 02/22265 A1

MICROFABRICATED REACTION CHAMBER SYSTEM

The present invention relates to a
microfabricated reaction chamber system for carrying
5 out a nucleic acid sequence amplification and
detection process on a nucleic acid sample, and in
particular, but not exclusively to such a system for
use in carrying out NASBA amplification and
fluorescent molecular beacon probe detection process
10 steps.

By the term microfabricated device or system as
used herein is meant any device manufactured using
processes that are typically, but not exclusively,
15 used for batch production of semiconductor
microelectronic devices, and in recent years, for the
production of semiconductor micromechanical devices.
Such microfabrication technologies include, for
example, epitaxial growth (eg vapour phase, liquid
20 phase, molecular beam, metal organic chemical vapour
deposition), lithography (eg photo-, electron beam-,
x-ray, ion beam-), etching (eg chemical, gas phase,
plasma), electrodeposition, sputtering, diffusion
doping and ion implantation. Although non-crystalline
25 materials such as glass may be used, microfabricated
devices are typically formed on crystalline
semiconductor substrates such as silicon or gallium
arsenide, with the advantage that electronic circuitry
may be integrated into the system by the use of
30 conventional integrated circuit fabrication
techniques. Combinations of a microfabricated
component with one or more other elements such as a
glass plate or a complementary microfabricated element
are frequently used and intended to fall within the
35 scope of the term microfabricated used herein.

- 2 -

The isolation and purification of DNA and/or RNA from bacterial cells and virus particles is a key step in many areas of technology such as, for example, diagnostics, environmental monitoring, forensics and molecular biology research.

Microfabrication is an attractive construction method for producing devices for carrying out biological processes for which very small sample volumes are desirable, such as DNA sequence analysis and detection.

One such device, for carrying out a polymerase chain reaction (PCR) followed by a detection step is disclosed in US 5,674,742. Lamb wave pumps are used to transport DNA primers, polymerase reagents and nucleotide reagents from three separate storage chambers into a single reaction chamber as and when required to carry out a PCR process, with the temperature of the reaction chamber being cycled as required.

Another microfabricated device, for carrying out a chemical reaction step followed by an electrophoresis separation step, is disclosed in Analytical Chemistry 1994, 66, 4127-4132. Etched structures in a silicon substrate covered by a glass plate provide a reaction chamber and connections to buffer, analyte, reagent and analyte waste reservoirs, as well as an electrophoresis column connected to a waste reservoir.

Nucleic acid sequence-based amplification (NASBA) is a primer-dependent technology that can be used for the continuous amplification of nucleic acids in a single mixture at one temperature (isothermal nucleic

- 3 -

acid amplification method) and was one of the first RNA transcription-based amplification methods described. NASBA normally offers a simple and rapid alternative to PCR for nucleic acid amplification, and is capable of yielding an RNA amplification of a billion fold in 90 minutes. With respect to other amplification systems such as the PCR technique, the ability of NASBA to homogeneously and isothermally amplify RNA analytes extends its application range from viral diagnostics to the indication of biological activities such as gene expression and cell viability. NASBA technology is discussed, for example, in Nature volume 350 pages 91 and 92.

Nucleic acid amplification in NASBA is accomplished by the concerted enzyme activities of AMV reverse transcriptase, RNase H, and T7 RNA polymerase, together with a primer pair, resulting in the accumulation of mainly single-stranded RNA that can readily be used for detection by hybridization methods. The application of an internal RNA standard to NASBA results in a quantitative nucleic acid detection method with a dynamic range of four logs but which needed six amplification reactions per quantification. This method is improved dramatically by the application of multiple, distinguishable, internal RNA standards added in different amounts and by electrochemiluminescence (ECL) detection technology. This one-tube quantitative (Q) NASBA needs only one step of the amplification process per quantification and enables the addition of the internal standards to the clinical sample in a lysis buffer prior to the actual isolation of the nucleic acid. This approach has the advantage that the nucleic acid isolation efficiency has no influence on the outcome of the quantitation, which in contrast to methods in which

- 4 -

the internal standards are mixed with the wild-type nucleic acid after its isolation from the clinical sample. Quantitative NASBA is discussed in Nucleic Acid Research (1998) volume 26, pages 2150-2155.

5

Post-NASBA product detection, however, can still be a labour-intensive procedure, normally involving enzymatic bead-based detection and electrochemiluminescent (ECL) detection or fluorescent correlation spectrophotometry. However, as these methodologies are heterogeneous or they require some handling of sample or robotic devices that are currently not cost-effective they are relatively little used for high-throughput applications. A homogeneous procedure in which product detection is concurrent with target amplification by the generation of a target-specific signal would facilitate large-scale screening and full automation. Recently, a novel nucleic acid detection technology, based on probes (molecular beacons) that fluoresce only upon hybridization with their target, has been introduced.

Molecular beacons are single-stranded oligonucleotides having a stem-loop structure. The loop portion contains a sequence complementary to the target nucleic acid, whereas the stem is unrelated to the target and has a double-stranded structure. One arm of the stem is labelled with a fluorescent dye, and the other arm is labelled with a non-fluorescent quencher. In an isolated state the probe does not produce fluorescence because absorbed energy is transferred to the quencher and released as heat. When the molecular beacon hybridizes to its target it undergoes a conformational change that separates the fluorophore and the quencher, and the bound probe fluoresces brightly. Molecular beacon probes are

35

- 5 -

discussed, for example, in US 6,037,130 and in Nucleic Acids Research, 1998, vol. 26, no.9.

5 Even the one tube quantitative Q-NASBA process generally requires at least two steps, typically a first primer annealing step carried out at about 65 degrees Celsius followed by an amplification and detection step carried out at about 41 degrees Celsius. The enzymes required for the second step
10 would be denatured by the elevated temperature required for the first step, so must be added once the temperature of the process components has fallen sufficiently. Furthermore, as for most nucleic acid sequence amplification and detection processes, NASBA
15 requires reagents specific to the target nucleic acid sequence to be used. To carry out simultaneous analysis of a DNA/RNA sample for a number of different target nucleic acid sequences generally requires the handling of a large number of different reagent sets,
20 each requiring separate handling and use in separate test tubes.

The present invention seeks to address at least some of the problems of the prior art.

25

Accordingly, the present invention provides a microfabricated reaction chamber system for carrying out a nucleic acid sequence amplification and detection process on a nucleic acid sample, the process comprising at least first and second process
30 steps using first and second reagents, the device comprising:

an inlet port;
a first reaction chamber in communication with
35 the inlet port, for carrying out the first process step;

- 6 -

a second reaction chamber in communication with the first reaction chamber, for carrying out the second process step; and

5 an outlet port in communication with the second reaction chamber.

A single fluid path, whereby the sample is passed into the first reaction chamber for carrying out the first process step, then into the reaction second
10 chamber for the second process step, simplifies construction and operation of the device.

By providing two separate reaction chambers, separate reagents for separate process steps may be conveniently preloaded into the system before use, and
15 no active components are then required to move reagents within the device during use. The reagents for second and any subsequent process steps may be protected from damaging environmental conditions such as elevated temperatures required during earlier
20 process steps.

A sample loading chamber may be provided between the inlet port and the first reaction chamber, for example to facilitate controlled loading of a sample
25 into the device or first reaction chamber.

The first reagent (which may be substantially dry) is preferably preloaded within the first reaction chamber and the second reagent (which may be
30 substantially dry) is preferably preloaded within the second reaction chamber. This may conveniently be carried out during manufacture of the system. To enhance storage qualities the reagent mixes may be lyophilised or dried *in situ*.

35

The nucleic acid sample may be derived from, for

- 7 -

example, a biological fluid, a dairy product, an environmental fluids and/or drinking water. Examples include blood, serum, saliva, urine, milk, drinking water, marine water and pond water. For many

5 complicated biological samples such as, for example, blood and milk, it will be appreciated that before one can isolate and purify DNA and/or RNA from bacterial cells and virus particles in a sample, it is first

10 necessary to separate the virus particles and bacterial cells from the other particles in sample. It will also be appreciated that it may be necessary to perform additional sample preparation steps in order to concentrate the bacterial cells and virus

15 particles, i.e. to reduce the volume of starting material, before proceeding to break down the bacterial cell wall or virus protein coating and isolate nucleic acids. This is important when the starting material consists of a large volume, for

20 example an aqueous solution containing relatively few bacterial cells or virus particles. This type of starting material is commonly encountered in environmental testing applications such as the routine monitoring of bacterial contamination in drinking

25 water.

The system is preferably designed to cater for a sample volume of ≤ 50 nl, preferably ≤ 20 nl, more preferably ≤ 10 nl. Thus the volume of each of the reaction chambers will typically be ≤ 500 nl, more

30 typically ≤ 300 nl, still more typically ≤ 150 nl.

Preferably, one or more temperature controllers are provided to enable the first process step to be carried out at a first temperature, and to enable the

35 second process step to be carried out at a second temperature that is lower than the first temperature.

For example, separate first and second temperature controllers may be used to control the temperatures of the first and second process steps. Various nucleic acid amplification processes, such as NASBA processes, which require higher temperatures for an earlier process step, which would denature reagents used in a later process steps, may in this way be conveniently and easily carried out in a microfabricated reaction chamber system or device.

10

Preferably, means are provided for heating the contents of the first chamber to a temperature of from 60 to 70°C, more preferably from 63 to 67°C, still more preferably \approx 65°C. Preferably, means are provided for heating the contents of the second chamber to a temperature of up to 41.5°C, more preferably \approx 41°C.

15

Preferably, the first temperature controller comprises a first temperature sensor positioned adjacent to the first reaction chamber and the second temperature controller comprises a second temperature sensor positioned adjacent to the second reaction chamber.

20

Preferably, the first temperature controller comprises a first controllable electric heat source (for example an electrical resistor element) positioned adjacent to the first reaction chamber and the second temperature controller comprises a second controllable electric heat source (for example an electrical resistor element) positioned adjacent to the second reaction chamber.

25

The system may thus preferably include integrated electrical heaters and temperature control.

30

35

- 9 -

Peltier element(s) and/or thermocouple(s) may be used to maintain the sample at the desired temperature in the first and/or second chambers, preferably to within ± 0.5 °C. In particular, thermocouples may be used to measure the temperature of the first and second chambers, wherein the thermocouples are linked by one or more feedback circuits to Peltier elements for heating the sample to the desired temperature in the first and second chambers.

10

A thermal barrier may advantageously be provided to substantially thermally isolate the second chamber from the first chamber.

15

The outlet port may be provided with a pressure control valve or flow control valve, to control the flow of the sample and/or other fluids through the system. This may be used in conjunction with a pump, which may be provided at the inlet end of the system, to control the flow of fluids into and through the reaction chambers.

20

The system may be provided with an optical interface for excitation and/or detection purposes. Accordingly, if optical observations of the contents of the second reaction chamber are required, then at least one wall defining the second chamber comprises an optically transparent substance or material, for example glass.

25

30

Preferably, the system comprises at least one optical source arranged for exciting fluorescence in material contained within the second reaction chamber, and at least one optical detector, arranged to detect said fluorescence. For example, molecular beacon probes may be provided in the second reaction chamber

35

- 10 -

to detect one or more target nucleic acid sequences. These probes fluoresce when in the presence of target nucleic acid sequences, thereby enabling detection and quantification of such sequences. The system thus
5 provided amplification combined with optical-fluorescence detection. However, other detection methods could be used, for example, using impedance measurements.

10 Preferably, the optical source is provided by one or more light emitting diodes, and the optical detector comprises at least one avalanche photodiode. However, other sources and detectors could also be used. For example the optical detector could comprise
15 at least one photomultiplier tube.

Preferably, a bandpass filter is provided to filter the light impinging on the detector, in particular to filter out light emitted by the optical
20 source.

A micro-lens may be provided to direct the fluorescence onto the detector or, alternatively, a confocal microscope could be used.

25 An integrated microfabricated reaction chamber system may be provided with a plurality of sets interconnected first and second reaction chambers as described above, each of which may have a separate
30 outlet port. In this way a range of different analysis processes may be carried out simultaneously within a single micromachined device.

A single set of first and second reaction
35 chambers, or multiple sets of first and second reaction chambers may be connected to a common inlet

- 11 -

port. Such an inlet port may advantageously be provided with a micro pump to pass the sample into the reaction chambers.

5 The system will typically be formed from or
comprise a semiconductor material, although dielectric
(eg glass, fused silica, quartz, polymeric materials
and ceramic materials) and/or metallic materials may
also be used. Examples of semiconductor materials
10 include one or more of: Group IV elements (i.e.
silicon and germanium); Group III-V compounds (eg
gallium arsenide, gallium phosphide, gallium
antimonide, indium phosphide, indium arsenide,
aluminium arsenide and aluminium antimonide); Group
15 II-VI compounds (eg cadmium sulphide, cadmium
selenide, zinc sulphide, zinc selenide); and Group
IV-VI compounds (eg lead sulphide, lead selenide, lead
telluride, tin telluride). Silicon and gallium
arsenide are preferred semiconductor materials. The
20 system may be fabricated using conventional processes
associated traditionally with batch production of
semiconductor microelectronic devices, and in recent
years, the production of semiconductor micromechanical
devices. Such microfabrication technologies include,
25 for example, epitaxial growth (eg vapour phase, liquid
phase, molecular beam, metal organic chemical vapour
deposition), lithography (eg photo-, electron beam-,
x-ray, ion beam-), etching (eg chemical, gas phase,
plasma), electrodeposition, sputtering, diffusion
30 doping and ion implantation. Although non-crystalline
materials such as glass and polymeric materials may be
used, the microfabricated system is usually formed on
crystalline semiconductor substrates such as, for
example, silicon or gallium arsenide, with the
35 advantage that electronic circuitry may be integrated
into the system by the use of conventional integrated

- 12 -

circuit fabrication techniques. Combinations of a microfabricated component with one or more other elements such as a glass plate or a complementary microfabricated element are frequently used and
5 intended to fall within the scope of the term microfabricated used herein.

Examples of polymeric materials include hydrophilic polymers in order to prevent unspecific
10 binding of cells and proteins. Suitable examples include PMMA (Polymethyl methacrylate), COC (Cyclo olefin copolymer), PL (Polylactide), PBT (Polybutylene terephthalate) and PSU (Polysulfone). The system may be formed by plastic replication of, for example, a
15 silicon master.

The one or more systems will typically be integrally formed. The systems may be microfabricated on a common substrate material, preferably a
20 semiconductor material, although a dielectric substrate material such as, for example, glass or a ceramic material could be used.

The microfabricated system may be designed to be
25 disposable after it has been used once or for a limited number of times. This is an important feature because it reduces the risk of contamination.

The microfabricated system may be incorporated
30 into an apparatus for the analysis of, for example, biological fluids, dairy products, environmental fluids and/or drinking water. Again, the apparatus may be designed to be disposable after it has been used once or for a limited number of times.

35

The microfabricated system/apparatus may be

- 13 -

included in an assay kit for the analysis of, for example, biological fluids, dairy products, environmental fluids and/or drinking water, the kit further comprising means for contacting the sample with the device. Again, the assay kit may be designed to be disposable after it has been used once or for a limited number of times.

The microfabricated system as herein described is also intended to encompass nanofabricated devices.

In a preferred embodiment, the system described above is formed from a silicon or silicon-comprising substrate (although other of the above recited materials may be used), capped with a top plate, which may be made of glass (for example Pyrex), each reaction chamber being defined by a recess in a surface of the substrate and the adjacent surface of the top plate. A channel is provided between the reaction chambers. Preferably, and in particular if optical observations of the contents of the second reaction chamber are required, the top plate may be made of glass (for example Pyrex) or another optically transparent substance or material. The combination of silicon and glass provides suitable thermal, surface and optical properties, as well as adequate surface properties. It is possible to define by, for example, etching microfluidic channels, reaction chambers and fluid interconnects in the silicon substrate with accurate microscale dimensions. In this manner a silicon wafer with an etched microstructure may be anodically bonding it to a pyrex wafer thereby forming the enclosed chambers and channels. The glass wafer allows the reagents to be optically excited and detected through the glass. The silicon wafer enables electronic components to be integrated.

- 14 -

If the system includes an optical source arranged for exciting fluorescence in material contained within the second reaction chamber, and an optical detector, arranged to detect said fluorescence, the surface in the second reaction chamber is preferably optically smooth. It has been found that the surface roughness of the wall(s) defining the second chamber on which light may be incident should be less than approximately 1/10th of the wavelength of the light. Reactive-Ion-Etching (RIE) of said wall(s) of the second chamber has been found to achieve a good surface quality with a roughness of less than approximately 40 nm.

Different regions of a channel may define the an inlet port and the first reaction chamber. Similarly, different regions of a channel may define the an the second reaction chamber and the outlet port.

The present invention also provides a microfabricated reaction chamber system for carrying out a nucleic acid sequence amplification and detection process on a nucleic acid sample in a single reaction chamber, the device comprising:

- a reaction chamber having an inlet port and an outlet port and at least one wall that comprises an optically transparent material;
- means for heating a sample contained the reaction chamber to a temperature of $\leq 41.5^{\circ}\text{C}$ (preferably from 40.5 to 41.5°C);
- at least one optical source arranged adjacent said at least one wall for exciting fluorescence in a sample contained in the reaction chamber; and
- at least one optical detector, arranged to detect said fluorescence through said at least one wall.

- 15 -

Such a device dispenses with the first chamber and may be used in circumstances where the target does not require a pre-denaturing step. Real-time amplification and detection takes place in a single microfabricated reaction chamber. The features (for example materials and construction) described herein in relation to the two chamber system are also pertinent and relevant to the single chamber system.

The present invention also provides a device which includes a microfabricated reaction chamber system as herein described, together and preferably in fluid communication with one or more of: (i) means for filtering a sample prior to carrying out the method according to the present invention, for example to substantially remove particles contained in the sample which are larger in size than bacteria particles; and/or (ii) means for separating virus particles and/or bacterial cells from the other particles in a sample prior to carrying out the method according to the present invention; and/or (iii) means for concentrating bacterial cells and/or virus particles, i.e. to reduce the volume of starting material, prior to carrying out the method according to the present invention; and/or (iv) means for breaking down the bacterial cell wall or virus protein coating and isolate nucleic acids prior to carrying out the method according to the present invention.

The present invention also provides a method of carrying out a nucleic acid sequence amplification and detection process on a nucleic acid sample in a microfabricated reaction chamber system, the process comprising at least a first process step using a first

- 16 -

reagent and a second process step using a second reagent, the method comprising the steps of:

passing the sample into a first reaction chamber and mixing the sample with the first reagent;

5 retaining the sample in the first reaction chamber for a first interval to carry out the first process step;

passing the sample from the first reaction chamber into the second reaction chamber and mixing
10 the sample with the second reagent;

retaining the sample in the second reaction chamber for a second interval to carry out the second process step; and

during the second interval, measuring a physical
15 phenomenon indicative of the presence of the target nucleic acid sequence.

The method is particularly advantageous when the process is a NASBA or quantitative NASBA process. The
20 first and second reagents may comprise NASBA primers, ribonucleoside and deoxyribonucleoside triphosphates, enzymes for carrying out a NASBA reaction and molecular beacon probe oligonucleotide.

25 Preferably, the method further comprises the steps of maintaining the contents of the first reaction chamber at a first temperature during the first interval and maintaining the contents of the second reaction chamber at a second temperature during
30 the second interval, wherein the first temperature is higher than the second temperature, and is sufficiently high to denature the second reagent. The first temperature is typically from 60 to 70°C, preferably from 63 to 67°C, more preferably \approx 65°C.
35 The second temperature is typically 35 to 45°C, preferably \leq 41.5°C, more preferably \approx 41°C.

- 17 -

Preferably, the step of measuring comprises the steps of irradiating the second chamber to excite fluorescence and detecting any such fluorescence, for example in molecular beacon probes present in the second chamber which are adapted to fluoresce on annealing with a target nucleic acid sequence.

The method preferably uses the microfabricated reaction chamber system as herein described. In circumstances where the target does not require a pre-denaturing step, then a single chamber system as herein described may be used. In that case, the method may comprise:

assembling a reaction mixture in the single chamber, said mixture comprising the nucleic acid sample, NASBA primers, enzymes for carrying out a NASBA reaction, ribonucleoside and deoxyribonucleoside triphosphates, and molecular beacon probe oligonucleotide;

heating said mixture contained in said reaction chamber to a temperature of $\leq 41.5^{\circ}\text{C}$ (preferably from 40.5 to 41.5°C);

exciting fluorescence in said mixture contained in said reaction chamber by means of said at least one optical source; and

detecting fluorescence in said mixture through said at least one wall by means of said at least one optical detector.

It will be appreciated that one or more of the NASBA primers, enzymes for carrying out a NASBA reaction, ribonucleoside and deoxyribonucleoside triphosphates, and molecular beacon probe oligonucleotide may be preloaded in the single chamber. Alternatively, or in combination with partial pre-loading, one or more of the aforementioned

- 18 -

reactants may be mixed with the sample prior to passing it to the chamber.

5 A number of embodiments of the invention will now be described, with reference to the accompanying drawings, of which:

10 Figure 1 is a plan view of a microfabricated reaction chamber device according to a first preferred embodiment of the present invention, for carrying out a nucleic acid sequence amplification and detection process;

15 Figure 2 is a sectional view along line X-X of figure 1;

20 Figure 3 is a plan view of the lumen structure of a microfabricated reaction chamber device according to a second preferred embodiment of the invention;

Figure 4 is a plan view of the lumen structure of a microfabricated reaction chamber device according to a third preferred embodiment of the invention.

25 Referring to figure 1 there is shown a plan view of a microfabricated reaction chamber device 10 for carrying out first and second steps of a nucleic acid amplification and detection process. The device is provided with one or more fluid flow lumens consisting
30 of channels and chambers for carrying a fluid sample introduced through an inlet port 20. The inlet port is connected to a supply channel system 30 which provides branches to one or more separate sets of reaction chambers, only one set of which is shown in figure 1.
35 Each set of reaction chambers comprises a first reaction chamber 40 connected to the supply channel

- 19 -

system 30, a transfer channel 32 connecting the first reaction chamber 40 and a second reaction chamber 50, and an exit channel 34 connected between the second reaction chamber and an outlet port 60.

5

A number of first heating elements 42 and a first temperature sensor 44 are provided adjacent to the first reaction chamber 40. These components are connected to control circuitry which enables the temperature of the walls and contents of the first reaction chamber to be carefully controlled. A number of second heating elements 52 and a second temperature sensor 54, along with suitable control circuitry, are similarly provided adjacent to the second reaction chamber.

10
15

Turning now to figure 2, there is shown a sectional view of the micro reaction chamber device of figure 1 along line X--X. The device is constructed by etching the required channels and chambers from the surface of a silicon substrate 12. A glass top plate 14 is then anodically bonded to the surface of the silicon substrate 12 to enclose the channels and chambers. The top plate may advantageously be made of a borosilicate glass such as Pyrex (trademark), which has a low coefficient of thermal expansion.

20
25

The inlet port 20 comprises an inlet port chamber 24 etched into the substrate and overlain by an inlet port aperture 22 in the glass plate 14. An inlet port connector 26 is bonded in position over or accepted into the inlet port aperture 22. The inlet port may equally comprise a structure adapted to accept the tip of a micropipette or similar device.

30
35

The first 42 and second 52 heating elements are

- 20 -

provided by electrical resistance elements bonded,
printed, or otherwise provided on the lower surface of
the silicon substrate, close to the appropriate
reaction chamber. The first and second temperature
5 sensors 44,54 are provided by, for example,
thermistors or platinum resistors bonded, printed or
otherwise constructed on the underside of the
substrate directly underneath the appropriate reaction
chamber.

10

The outlet port 60 is provided by an outlet port
chamber 62 formed from an etched recess in the upper
surface of the silicon substrate 12, an outlet port
aperture 64 in the glass top plate directly above the
15 outlet port chamber, and an outlet port valve 66
fitted into or on top of the outlet port aperture. The
outlet port valve is electrically controllable to
assist in controlling the flow of fluids through the
reaction chambers, for example by allowing air or
20 fluid flow out of the outlet port only when the
pressure in the outlet port chamber 62 reaches or
exceeds a certain controlled value.

An optical system 70 is provided to stimulate and
25 detect fluorescence of particular materials contained
within the second reaction chamber 50. Such an optical
system may clearly be provided in a variety of ways,
but in the embodiment shown in figure 2 there are
provided two light emitting diodes (LEDs) 72 arranged
30 to irradiate the contents of the second reaction
chamber 50 through the glass plate, a cascade
photodiode detector 76 for detecting fluorescence
photons emitted by material in the second reaction
chamber 50, and an optical bandpass filter 74 to
35 shield the detector 76 at least from light having
wavelengths generated by the LEDs 72. In the preferred

- 21 -

embodiment one of the LEDs 72 emits light having a wavelength of about 488 nm, and the other LED emits light having a wavelength of about 590 nm. The optical bandpass filter 74 limits the wavelengths of light reaching the detector 76 to between 515 nm and 565 nm and above 590 nm.

The optical system is provided with suitable control circuitry to carry out the irradiation and detection process and to forward data regarding the detected fluorescence to data processing facilities.

During construction of the microfabricated reaction chamber device first and second reagents for carrying out first and second process steps are deposited in the first and second reaction chambers. This may be carried out before the glass top plate is bonded to the substrate, for example, by micro pipetting each reagent into the appropriate reaction chamber and, if required, carrying out a drying or lyophilisation procedure to reduce each reagent to a dry deposit. Alternatively, the reagents could be injected in fluid form through the inlet and outlet ports 20,60, and then lyophilised if required.

To use the device, a prepared sample is pumped through the inlet port 20 (for example by a micro pump) and into the first reaction chamber 40, where it mixes with the first reagent. The first reaction chamber is maintained at a desired temperature, or the temperature is varied in a desired time dependent manner, in order to carry out the first process step. By applying further pressure at the inlet port the sample is then pumped from the first reaction chamber 40 to the second reaction chamber 50 where it mixes with the second reagent. The second reaction chamber

- 22 -

is then maintained at a desired temperature, or the temperature is varied in a desired time dependent manner in order to carry out the second process step. During the second process step the optical system is used to stimulate and detect fluorescence in the material contained within the second reaction chamber as required, in particular to obtain information about the processed sample.

Transport of fluids through the system may be controlled by controlling the pumping of the sample through the inlet port 20. Control of the pressure in or flow through the system by means of the control valve 66 in the outlet port 60 may also be used. If a single pumping device is used to feed a number of sets of parallel reaction chambers through supply channel system 30, individual pressure control valves 66 for each set of first and second reaction chambers may be used to ensure the correct fluid flow through each set of reaction chambers. Feedback data regarding the fluid flow may be obtained by detecting the presence of the sample in one or both reaction chambers, for example by detecting a fluorescence signal from the second reaction chamber.

Use of the described first embodiment of a microfabricated reaction chamber device for carrying out a Q-NASBA nucleic acid sequence amplification process, followed by detection of the target sequence by means of molecular beacon probes will now be described.

During or after manufacture of the microfabricated reaction chamber device, ten nanolitres of a first reagent are deposited in the first reaction chamber, which is approximately 50 x

- 23 -

300 x 100 micrometers in size. An appropriate corresponding cross sectional size for the various connecting channels is about 50x50 micrometers. The first reagent consists of about 0.5 nl of NASBA buffer and 0.5 nl of primer mix solution. The NASBA buffer consists of the final concentration of 20 micromolar molecular probes (specific towards the target RNA sequence), 100 nmol/nl of ROX (fluorescence control), 5 mM of each dNTP, 2 mM of ATP, UTP and CTP, 6.5 mM GTP, and 2.5 mM ITP, 2.5 mM dithiotreitol, 350 mM KCl, 60 mM MgCl₂, 200 mM Tris-HCl (pH 8.5). The primer mix solution consists of 45% DMSO and 0.2 microM each of the antisense and sense primers.

One nanolitre of a second reagent is deposited in the second reaction chamber, which is about the same size as the first reaction chamber. The second reagent consists of 1875 mM sorbitol, 12.5 microgram BSA, 0.4 U RNase H, 160 U T7 RNA polymerase and 32 U AMV-reverse transcriptase. The first and second reagents are then lyophilised.

A sample containing DNA/RNA is prepared, for example by culturing a cell sample, concentrating the cultured cell sample, carrying out a lysis step to liberate DNA and RNA from the cultured cells, and purifying the sample to selectively retain DNA/RNA fragments. About 9 nl of the prepared sample is then passed into the first reaction chamber where it mixes with the first reagent, and is held at 65 degrees Celsius for 5 minutes. The sample is then passed into the second reaction chamber and held there at 41 degrees Celsius for about 60 minutes, or until the fluorescence signal has reached an optimum level. During this time, each of the two LEDs is alternately switched on and off for a period of five seconds or

- 24 -

more. The fluorescence detected by the detector during each 5 second interval is recorded in order to establish the quantity of the target nucleic acid sequence present in the second reaction chamber.

5

A number of variations in and alternatives to the first preferred embodiment will now be described. These variations also generally apply to the second and third preferred embodiments described below.

10 Figures 1 and 2 show only a single set of reaction chambers, comprising two interconnected reaction chambers and an outlet port. For many purposes it may be desirable to provide two or more sets of reaction chambers in a single device. The plurality of sets of

15 reaction chambers may be fed by a single inlet port connected to a branched supply channel system, or by multiple inlet ports. Each set of reaction chambers may be provided with a separate outlet port 66 having a pressure or flow control valve 66 to allow fluid

20 flow through each individual system to be accurately controlled.

Although a set of reaction chambers having only first and second interconnected reaction chambers has

25 been described in respect of the first preferred embodiment, clearly a similar reaction chamber system could comprise other combinations of reaction chambers with appropriate interconnections to carry out a variety of reaction and detection processes.

30

If a plurality of sets of reaction chambers are provided in a single device, then each set of reaction chambers can be charged with reagents to carry out a different analysis process. For example, each of many

35 sets of reaction chambers could be provided with reagents to detect a different target nucleic acid

- 25 -

sequence. In this way, a plurality of different nucleic acid sequences could be tested for simultaneously using one device preconfigured with all the necessary reagents.

5

Flow through the one or more sets of reaction chambers may be driven by a pump such as a syringe, rotary pump or precharged vacuum or pressure source external to the device. Alternatively, a micro pump or vacuum chamber, or lamb wave pumping elements could be provided as part of the device itself. Other combinations of flow control elements including pumps, valves and precharged vacuum and pressure chambers may clearly be used to control the flow of fluids through the reaction chambers. Electronic control circuitry will generally be required to control the operation of the active flow control elements used, such as pumps and valves. This control may be carried out, for example, on the basis of carefully timed operation of the active flow control elements, by using dedicated sensors to detect fluid presence or flow, or by obtaining feedback from the flow control elements themselves to determine the presence or location of pumped fluids. Other possible mechanisms for transporting fluids within the system include electro-osmotic flow.

In the preferred embodiment described above the reagents are introduced into the reaction chambers during manufacture of the device and retained there until the device is used, for example in solid or liquid form. Clearly, the reagents could equally be held in other chambers ancillary to the main reaction chambers, and introduced when required into the appropriate reaction chambers.

35

- 26 -

To excite fluorescence in the material contained in the second reaction chamber, the preferred embodiment makes use of LEDs. These LEDs could be bonded or mounted to the upper surface of the glass top plate. Alternatively, they could be held in position by apparatus external to the microfabricated reaction chamber device itself. For a device having multiple sets of reaction chambers, one or more separate LEDs having the desired emission characteristics could be provided for each second reaction chamber, for particular groups of reaction chambers, or for the whole device. Other radiation sources could of course be used, for example discharge tube or laser sources, perhaps channelled to the appropriate reaction chambers by means of fibre optics.

To detect fluorescence, the preferred embodiment makes use of an avalanche photodiode provided with a filter to exclude light of unwanted frequencies. A lens structure may be provided, for example formed by a surface of the glass top plate or separately provided to assist in focussing the fluorescence photons towards the detector. Other detection systems may equally be used, for example a confocal microscope arrangement, perhaps scanning across multiple second reaction chambers, in combination with a photomultiplier tube detector.

Various physical phenomena could be used instead of or as well as fluorescence to determine the progress or results of reaction processes carried out in the second reaction chamber, or indeed in the first reaction chamber. For example, process steps may be used that exhibit particular impedance characteristics, detectable by a simple resistance

- 27 -

measurement, or heating/cooling characteristics which could easily be measured using the temperature control components already described, possibly with some reference temperature detection elements located away
5 from the reaction chamber concerned.

Referring now to figure 3 there is shown in plan view the fluid carrying lumens of a device according to a second embodiment of the invention. Other aspects
10 of the second embodiment, such as temperature control apparatus, inlet and outlet ports, and illumination and fluorescence detection apparatus are not shown, but may be provided as already described above in respect of the first preferred embodiment.

15 The device 100 of the second embodiment is provided with first and second reaction chambers 110,112 interconnected by an intermediate channel 114. A loading chamber 116, of the same dimensions as each
20 of the reaction chambers, is connected to the first reaction chamber 110 by a sample transfer channel 118. An exhaust channel to allow fluid or gas release 120 is connected to the second reaction chamber 112.

25 A sample loading channel 122 is connected to the loading chamber 116 to allow a DNA/RNA sample to be introduced into the loading chamber 116. A sample propulsion channel 124 connects to the sample loading channel, at a point adjacent to the loading chamber
30 116. A first reagent loading channel 126 connects to the sample transfer channel 118 at a point adjacent to the first reaction chamber 110, and a second reagent loading channel 128 connects to the intermediate channel 114 adjacent to the second reaction chamber
35 112.

- 28 -

The device 100 may be fabricated from an etched silicon wafer closed with a glass top plate. The dotted boundary in figure 3 shows a nominal boundary for the top plate.

5

A suitable channel depth for the device of the second preferred embodiment is 50 μm . A suitable volume for the reaction and loading chambers is about 10 nanolitres, which can be achieved using a chamber with lateral dimensions of about 450 μm x 450 μm and a depth of 50 μm , and by rounding the corners with a radius of curvature of 100 μm . Rounding the corners in this way reduces the chances of air pockets lodging in the chambers.

10
15

By making some parts of the fluid carrying lumens more hydrophobic or hydrophilic than other parts, fluid can be held preferentially in certain regions. For the present embodiment, silicon oxide, which can be grown in an oxygen plasma machine on a silicon substrate, is used to create hydrophilic regions, while hydrophobic regions are defined by etching away patterns of silicon oxide using standard lithographic techniques.

20
25

Regions which are treated to be relatively hydrophobic in the second preferred embodiment are shown as hatched regions in the lumens of figure 3. These regions are: along the sample propulsion channel 124 from the junction with the sample loading channel 122 for about 1000 μm ; along the sample transfer channel 118 from the junction with the loading chamber 116 for about 100 μm and from the first reaction chamber for about 350 μm , along the first reagent loading channel 126 from the junction with the sample transfer channel 118 for about 100 μm ; along the

30
35

- 29 -

intermediate channel 114 from the junction with the first reaction chamber 110 for about 100 μm and from the junction with the second reaction chamber for about 100 μm ; along the second reagent loading channel 5 128 from the junction with the intermediate channel for about 100 μm ; and along the length of the exhaust channel.

Trenches may be formed in the silicon substrate 10 in appropriate locations to help thermally isolate the first and second reaction chambers from each other and from other parts of the device.

A variety of methods and apparatus familiar to 15 the person skilled in the art may be used to input and control the flow of sample fluid and reagents within the lumens of the second embodiment, including the methods and apparatus described above in respect of the first preferred embodiment. For example, fluid 20 may be injected into a lumen of the device using a fine sequencing pipette tip guided into the end of one of the channels at the edge of the glass top plate by a trench formed at the end of the channel. An airtight and watertight seal may be made between the pipette 25 tip and the channel using epoxy. Alternatively, a small hole, for example about 200 μm across, could be etched in the top plate centred on the end of a channel, and a pipette tip inserted into the hole and sealed if necessary.

30

Fluids may be manipulated using fine syringes capable of accurately delivering nanolitre volumes via the above-mentioned pipette tips into the device.

35

Reagents may be loaded into the first reaction chamber 110 by blocking the ends of all channels

- 30 -

except the first reagent loading channel 126 and exhaust channel 120 and using a fine syringe connected to the first reagent loading channel 126 to inject the require volume of reagents into the first reaction
5 chamber 110. The hydrophobic regions in the channels around the first reaction chamber 110 then encourage the reagents to stay in place. A similar procedure, wherein the ends of all channels except the second reagent loading channel 128 and the exhaust channel
10 120 are blocked off, can be used to load the second reagents into the second reaction chamber 112 where they are held in place by the hydrophobic regions surrounding that chamber.

15 The reagents, when loaded in the reaction chambers, may be dessicated by placing the device in a vacuum dessication chamber. A sample fluid may then be loaded into the sample loading chamber 116 by blocking off the ends of the first and second reagent
20 loading channels 126,128, but leaving other channels open, and injecting 10 nl of sample fluid through the sample loading channel 122. The hydrophobic region in the sample propulsion channel prevents sample fluid from entering this channel. Blocking off the end of
25 the sample loading channel 122, or keeping the syringe attached to this channel, another syringe is used to inject a driving fluid into the sample propulsion channel 124 so as to propel 10 nl of sample from the loading chamber 116 through the sample transfer
30 channel 118 and into the first reaction chamber 110, where the desired reactions between the sample and the crystallised reagents is allowed to occur, at a desired temperature.

35 The contents of the first reaction chamber 110 are then propelled, again using the syringe attached

- 31 -

to the end of the sample propulsion channel 124, into
the intermediate channel 114 which has a volume
slightly greater than the 10 nl of each of the
reaction chambers so as to prevent intermixing between
5 the reaction chambers. A 10 nl volume from the
intermediate channel is then propelled into the second
reaction chamber 112 and the desired reaction allowed
to occur between the sample and the reagents therein
at the required temperature. Detection of
10 fluorescence or other physical parameters in the
second reaction chamber may be carried out in any
suitable manner, as described elsewhere in this
document. Finally, the sample can be flushed from the
system through the exhaust channel.

15

If the reagents in the reaction chambers are not
dessicated but remain in a fluid form, then a slightly
different sequence to that described above is
required. To ensure sufficient volume in each
20 reaction chamber for the samples and reagents, a
reduced volume of reagent fluid should be loaded into
each reaction chamber, and it may be desirable to
carry out loading of reagents into reaction chambers
after the loading of the sample fluid. The first and
25 second reagent channels illustrated in figure 3
connect to the sample transfer channel 118 and the
intermediate channel 114 respectively at locations
adjacent to the respective reaction chambers, so that
effective mixing occurs when a reagent is added to the
30 sample already present in a reaction chamber.

It may be desirable to ensure that the
temperature of each reaction chambers is raised to the
appropriate operating levels before fluids are
35 introduced, and that the temperatures of other parts
of the lumens are stable. Temporal variations in

- 32 -

lumen temperature when air is present may lead to unpredictable fluid movements as air thermally expands or contracts.

5 Referring now to figure 4 there is shown in plan view the fluid carrying lumens of a device according to a third preferred embodiment of the invention. Other aspects of the third embodiment, such as general methods of construction, reaction chamber temperature control apparatus, inlet and outlet ports, and
10 illumination and fluorescence detection apparatus are not shown, but may be provided as already described above in respect of the first and second preferred embodiments.

15 The third embodiment comprises a single input channel 200 which splits into three branches which end in first, second and third parallel systems each comprising a first reagent loading chamber 202, a
20 first reaction chamber 204 and a second reaction chamber 206, connected in sequence. An exhaust channel 208 vents each second reaction chamber 206. Devices constructed according to the third embodiment may be used to carry out multiple sets of reactions in
25 parallel, using a fluid sample introduced via the common input channel 200.

 Although the preferred embodiments have been described as constructed using a glass top plate
30 bonded to an etched or otherwise machined silicon substrate, clearly a variety of other construction methods and materials could be used to carry out the invention. For example, chambers and/or other lumens could be created or made larger by forming recesses in
35 the top plate.

- 33 -

A microfabricated reaction chamber device embodying the invention may form an integral part of a larger microfabricated analysis device constructed as a single unit and containing, for example, apparatus
5 for carrying out various sample preparation steps, and containing the various reagents required to carry out the sample preparation steps. Such a microfabricated analysis device could contain some or all of the control and data analysis circuitry required for its
10 operation.

The microfabricated reaction chamber device or larger microfabricated analysis device described above may be designed for installation within a larger
15 analysis unit. Such an analysis unit would typically provide electrical connections to the various active components and sensors of the device, and could provide some or all of the required control and sensor circuitry. The analysis unit could also provide some
20 or all of the optical system, and means for pumping the sample through the reaction chambers. The unit could also provide DNA/RNA sample preparation equipment, although, as mentioned above, some or all of the sample preparation may be carried out in an
25 integral device of which the microfabricated reaction chamber device forms a part. Microfabricated reaction chamber devices embodying the invention may be thereby manufactured for once only use, being installed in an analysis unit when needed and disposed of after use.
30 The larger multi-use analysis unit could conveniently contain sufficient data handling and display equipment to provide a useful hand held analysis device.

Example

35

The following Example describes real-time NASBA

- 34 -

amplification reactions carried out on 10 nl and 50 nl microchips, or in 0.5 ml and 5 ml capillary tubes.

Microfabricated Reaction Chamber System

5

With reference to Figure 3, a silicon wafer with dry etched microstructure was provided and anodically bonded to a pyrex wafer to thereby define enclosed first and second chambers and associated channels.

10 The glass wafer allowed the reagents to be optically excited and detected through the glass. The silicon wafer enabled electronic components to be integrated by techniques conventional in the semiconductor fabrication art.

15

The protocol for loading the sample into the chip used a sequencing pipette tip with a 190 μm outer diameter, for loading the reagents. Two different designs were made. The first design included holes etched directly into the channels from the side.

20 Etching openings in the silicon into the channels from the side eliminates the need for fabricating holes in the glass wafer. This process may be performed simultaneously with the other process steps. The second design employed a tapered hold machined in the

25 525 μm thick pyrex glass. Holes may be made in pyrex glass by etching, powder blasting, or ultrasonic drilling. Powder blasting is preferred. This is a wafer process and all the holes on one wafer are

30 processed simultaneously.

Sample loading was done manually by inserting disposable, flexible polycarbonate tips with precision tapering into the holes. The samples were injected

35 with a syringe. A rig with five horizontally-mounted syringes was made. The tip positions coincide with

- 35 -

the holes on the chip. Micrometer screws were mounted on the syringes in order to control the volume accurately. This method is capable of moving nanoliter volumes of fluids in a controlled fashion.

5

The channels in the silicon wafer were defined by dry etching, which allowed the microfluidic design to include bends and rounded chambers (see Figure 3). The purpose of the first chamber is to load a defined volume. It is then transported through the chip with air pressure as a liquid plug. Preloaded enzymes are mixed together with the solution in the chamber to the right (see Figure 3). Syringes with micrometer screws are used to control the movement of the liquid plug through the system.

10
15

The NASBA process includes two accurately controlled heating steps at 65 and 41 °C. The latter preferably does not exceed 41.5 °C at any point, as this can result in degradation of the reagents. The chip consisted of two silicon blocks connected together by a thin bridge with a channel. Heat can only flow through the bridge of the pyrex glass. Integrated heating elements with temperature sensors may be designed into the mask layout or, alternatively, heating may be performed externally.

20

25

The pyrex wafer sealing the channels and chambers is transparent to optical light, and does not fluoresce. Blue light emitted from a 488 nm diode is filtered and focussed into the reaction chamber where it excites the fluorophores. Green fluorescent light, with a wavelength of 518 nm is emitted from the fluorophores, collected by a lens, and guided through filters and onto the detector. The surface in the reaction chamber had a roughness of less than 1/10th

30
35

- 36 -

of the wavelength of the light. Alcatel performed the Reactive-Ion-Etching (RIE) of the channels and the chambers, and obtained a surface quality with a roughness of less than 40 nm.

5

The temperature control of the blocks was done externally in the sample holder. Two aluminium blocks were sited on top of Peltier elements. In each block a thermocouple was provided for measuring the
10 temperature of the block with a feedback circuit to the Peltier elements. Both the thermocouple and the sample were attached with thermal grease to maximize the temperature accuracy and stability of the system. Temperature specifications were 41 and $65\text{ }^{\circ}\text{C} \pm 0.5\text{ }^{\circ}\text{C}$.
15 The temperature system incorporated digital PID controllers for regulating the temperature. The thermocouples were calibrated by two different methods: (i) a commercial FLUKE temperature calibration apparatus with thermocouples; and (ii)
20 platinum resistance sensors.

The NASBA process activates fluorescent markers, which can be excited and detected optically. An optical system was made for measuring these activated
25 fluorophores. Specifications were: Excitation at 494 nm; and Detection at 518 nm. Data were recorded during the application process. Because the fluorophores get bleached when exposed to blue light, there is a trade-off between the number of
30 measurements and bleaching.

The optical geometry comprised a blue light LED in conjunction with a bandwidth filter for shaping up of the spectral properties. A lens was used to focus
35 the light onto the reaction chamber. Additional lenses collect the fluorescent light from the

- 37 -

fluorophores, and guide it to a dichroic beam splitter. The latter projects the light onto a filter, which sits in front of a detector.

5 Materials

Amplification 1:-

Target Oligonucleotide Psek2:

10 5'GATTAGACATTTTCAGCATAACGCATAATCGGCCGGCTTCGCCTAGGCATATCC
TTTGCATGCTACTATATGGGACGATACGACCAAATGCCAGTCAGATAGCACAGT
AGCAGCGATTAA (SEQ ID NO:1)

Primer 1:

15 5' AATTCTAATACGACTCACTATAGGGAGAAGGGCTGCTACTGTGCTATCTGA
(SEQ ID NO:2)

Primer 2:

5' GACATTTTCAGCATAACGCATA (SEQ ID NO:3)

20 Probe:

5' (FAM)-ATCCTTTGCATGCTACTATA-(DABCYL) (SEQ ID NO:4)

Amplification 2:-

25 Target *Staphylococcus epidermidis*: (gene: sdrG,
GenBank Accession number AF245042)

Primer 1:

pos 584

30 5' AATTCTAATACGACTCACTATAGGGAGAAGGGGATTCAGTGTTACTCTCTA
(SEQ ID NO:5)

Primer 2:

pos 390

35 5' GATGCAAGGTCGCATATGAGACAAAAGACCCCTCAAGATA (SEQ ID
NO:6)

- 38 -

Probe:

pos 475

5' (FAM)-CCGTCGTACTGCCCAACAACCATCTCCGACGG-(DABCYL) (SEQ
ID NO:7)

5

FAM = carboxyfluorescein

DABCYL = 4-(4-Dimethylaminophenylazo)benzoyl

Methods:

10

SIGMACOTE™ (from Sigma-Aldrich Co, Ltd) was used to coat the walls of the chips and capillary tubes before the experiments.

15

The glass surfaces in the microchip and capillary tubes to be coated were clean and dry.

20

The glass surface in the microchambers and capillary tubes were covered with undiluted SIGMACOTE™. The reaction is almost instantaneous. Any excess SIGMACOTE™ solution was allowed to evaporate before use.

25

The two Peltier elements (Marlow Industries M1013T) in the optical detection system were calibrated to 41.0°C before use with a platinum electrode and a Hewlett Packard 34401A multimeter.

30

NASBA reagents were prepared according to the application manual supplied with the NucliSens™ Basic Kit supplied by Organon Teknika, as follows:

Preparation of a mastermix:

35

1. All reagents were equilibrated to room temperature.

- 39 -

2. Primers were diluted to a concentration of 10 mM and a primer mix prepared by mixing equal volumes of the first and second primers.
3. 80 ml of NucliSens reagent sphere diluent was
5 added to the reagent sphere.
4. 14 ml of KCl stock solution was mixed with 13.5 ml NASBA water.
5. The KCl/water mixture of step 4 was added to the reconstituted reagent sphere solution of step 3.
- 10 6. 10 ml of the primer mix was added to the solution of step 5.
7. 2.5 ml of the molecular beacon probe was added to the solution of step 6 to obtain a mastermix.
8. The mastermix so-prepared was used within 30
15 minutes.

Amplification procedure:

1. 5 ml of the target nucleic acid (sample, Psek2
20 oligonucleotide or *Staphylococcus epidermidis* genomic DNA) was pipetted into a fresh test tube.
2. 10 ml of the target RNA-specific primer solution was added.
3. Test tubes were incubated for 5 ± 1 minutes at
25 $65 \pm 1^\circ\text{C}$.
4. Test tubes were cooled at $41 \pm 0,5^\circ\text{C}$ for 5 ± 1 minutes.
5. 5ml of enzymes solution was added and the contents of the test tube mixed.

30

Chips:

- i. A syringe with a sequencing pipet tip (O. D. 0.19 mm) was used to add the sample to the 150-430 mm wide
35 holes in the upper glass of the chip and into reaction chamber number 3 where the measurements were done. The

- 40 -

whole chip was filled with the reaction mixture. Wax was used to seal the holes.

ii. The chip was then placed into a cavity in the optical detection system. Adjustments for accurate positions in the reaction chamber (10 or 50 nl) were made for each individual measurement. Excitation at 494 nm was used for the positioning. (LED from ELFA (Article no. 7500424)).

iii. Measurements were made using periodic measurement; 1 second measurement and 10 second pause for approximately 2 hours. The fluorescence detection was measured at 525 nm. (Detector Photo-Multiplier Tube, H5784 from Hamamatsu)

Capillary tubes 0.5 and 5 ml:

i. A syringe with a sequencing pipet tip (O. D. 0.19 mm) was used to add the sample to capillary tube. Wax was used to seal the holes.

ii. The chip was then placed into the optical detection system. Adjustments for accurate positions were made for each individual measurement. Excitation at 494 nm was used for the positioning (LED from ELFA (Article no. 7500424)).

iii. Measurements were made using periodic measurement; 1 s measurement and 10 s pause for approximately 2 hours. The fluorescence detection was measured at 525 nm. (Detector Photo-Multiplier Tube, H5784 from Hamamatsu).

The present invention provides a microfabricated reaction chamber system and method for real-time nucleic acid sequence amplification and detection. NASBA reactions can be performed in microscopic systems, with the added advantage of reduced reaction times.

CLAIMS:

1. A microfabricated reaction chamber system for carrying out a nucleic acid sequence amplification and detection process on a nucleic acid sample, the process comprising at least first and second process steps using first and second reagents, the device comprising:
- 5
- an inlet port;
- 10 a first reaction chamber in communication with the inlet port, for carrying out the first process step;
- a second reaction chamber in communication with the first reaction chamber, for carrying out the
- 15 second process step; and
- an outlet port in communication with the second reaction chamber.
2. A system as claimed in claim 1 wherein a sample loading chamber is provided between the inlet port and
- 20 the first reaction chamber.
3. A system as claimed in either claim 1 or claim 2 wherein the first reaction chamber is preloaded with
- 25 the first reagent, and the second reaction chamber is preloaded with the second reagent.
4. A system as claimed in any preceding claim wherein a first temperature controller is provided to control the temperature of the first process step and
- 30 a second temperature controller is provided to control the temperature of the second process step.
5. A system as claimed in claim 4 wherein the first
- 35 temperature controller is arranged such that the first process step is carried out at a first temperature,

- 42 -

and the second temperature controlled is arranged such that the second process step is carried out at a second temperature that is lower than the first temperature.

5

6. A system as claimed in either of claims 4 or 5 wherein the first temperature controller comprises a first temperature sensor positioned adjacent to the first reaction chamber and the second temperature
10 controller comprises a second temperature sensor positioned adjacent to the second reaction chamber.

7. A system as claimed in any preceding claim wherein the first temperature controller comprises a
15 first controllable electric heat source positioned adjacent to the first reaction chamber and the second temperature controller comprises a second controllable electric heat source positioned adjacent to the second reaction chamber.

20

8. A system as claimed in any preceding claim wherein the outlet port is provided with a pressure control valve or a flow control valve.

25 9. A system as claimed in any preceding claim further comprising at least one optical source arranged for exciting fluorescence in material contained within the second reaction chamber, and at least one optical detector, arranged to detect said
30 fluorescence.

35

10. A system as claimed in claim 9 wherein the optical source is provided by one or more light emitting diodes.

11. A system as claimed in claim 9 wherein the

- 43 -

optical detector comprises at least one avalanche photodiode.

5 12. A system as claimed in claim 9 wherein the optical detector comprises at least one photomultiplier tube.

10 13. A system as claimed in claim 9 wherein a bandpass filter is provided to filter the light impinging on the detector.

15 14. A system as claimed in claim 9 wherein a confocal microscope is provided to direct said fluorescence onto said detector.

15 15. A system as claimed in claim 9 wherein a micro lens is provided to direct said fluorescence onto said detector.

20 16. An integrally microfabricated reaction chamber system comprising a plurality of sets of interconnected first and second reaction chambers as claimed in any preceding claim.

25 17. A system as claimed in claim 16 wherein each of the plurality of sets of interconnected first and second reaction chambers is provided with a separate outlet port.

30 18. A system as claimed in claim 16 or 17 wherein the plurality of first reaction chambers are in communication with a common inlet port.

35 19. A system as claimed in claim 18 wherein the common inlet port is provided with a micro pump to pass the sample into the plurality of sets of first

- 44 -

and second interconnected reaction chambers.

20. A system as claimed in any preceding claim further comprising a substrate capped with an optically transmitting top plate, each reaction chamber being defined by a recess in a surface of the substrate and by the adjacent surface of the top plate.
21. An apparatus for the analysis of biological and/or environmental samples, the apparatus comprising a system as defined in any one of the preceding claims.
22. An assay kit for the analysis of biological and/or environmental samples, the kit comprising a system as defined in any one of claims 1 to 20 and means for contacting the sample with the device.
23. An apparatus as claimed in claim 21 or an assay kit as claimed in claim 22 which is disposable.
24. A method of carrying out a nucleic acid sequence amplification and detection process on a nucleic acid sample in a microfabricated reaction chamber system, the process comprising at least a first process step using a first reagent and a second process step using a second reagent, the method comprising the steps of:
- passing the sample into a first reaction chamber and mixing with the first reagent;
 - retaining the sample in the first reaction chamber for a first interval to carry out the first process step;
 - passing the sample from the first reaction chamber into a second reaction chamber and mixing with the second reagent;

- 45 -

retaining the sample in the second reaction chamber for a second interval to carry out the second process step; and

5 during the second interval, measuring a physical phenomenon indicative of the presence of the target nucleic acid sequence.

25. The method of claim 24, wherein the first reagent is preloaded in the first reaction chamber, and
10 wherein the second reagent is preloaded in the second reaction chamber.

26. The method of claims 24 or claim 25 further comprising the steps of:

15 maintaining the contents of the first reaction chamber at a first temperature during the first interval;

maintaining the contents of the second reaction chamber at a second temperature during the second
20 interval;

the first temperature being sufficiently high to denature the second reagent.

27. A microfabricated reaction chamber system for
25 carrying out a nucleic acid sequence amplification and detection process on a nucleic acid sample in a single reaction chamber, the device comprising:

30 a reaction chamber having an inlet port and an outlet port and at least one wall that comprises an optically transparent material;

means for heating a sample contained the reaction chamber to a temperature of $\leq 41.5^{\circ}\text{C}$ (preferably from 40.5 to 41.5°C);

35 at least one optical source arranged adjacent said at least one wall for exciting fluorescence in a sample contained in the reaction chamber; and

- 46 -

at least one optical detector, arranged to detect said fluorescence through said at least one wall.

28. A method of carrying out a nucleic acid
5 sequence amplification and detection process on a nucleic acid sample in a microfabricated reaction chamber system comprising a single chamber as defined in claim 27, the method comprising:

10 assembling a reaction mixture in the single chamber, said mixture comprising the nucleic acid sample, NASBA primers, enzymes for carrying out a NASBA reaction, ribonucleoside and deoxyribonucleoside triphosphates, and molecular beacon probe oligonucleotide;

15 heating said mixture contained in said reaction chamber to a temperature of $\leq 41.5^{\circ}\text{C}$ (preferably from 40.5 to 41.5°C);

20 exciting fluorescence in said mixture contained in said reaction chamber by means of said at least one optical source; and

detecting fluorescence in said mixture through said at least one wall by means of said at least one optical detector.

25

30

35

FIG. 1.

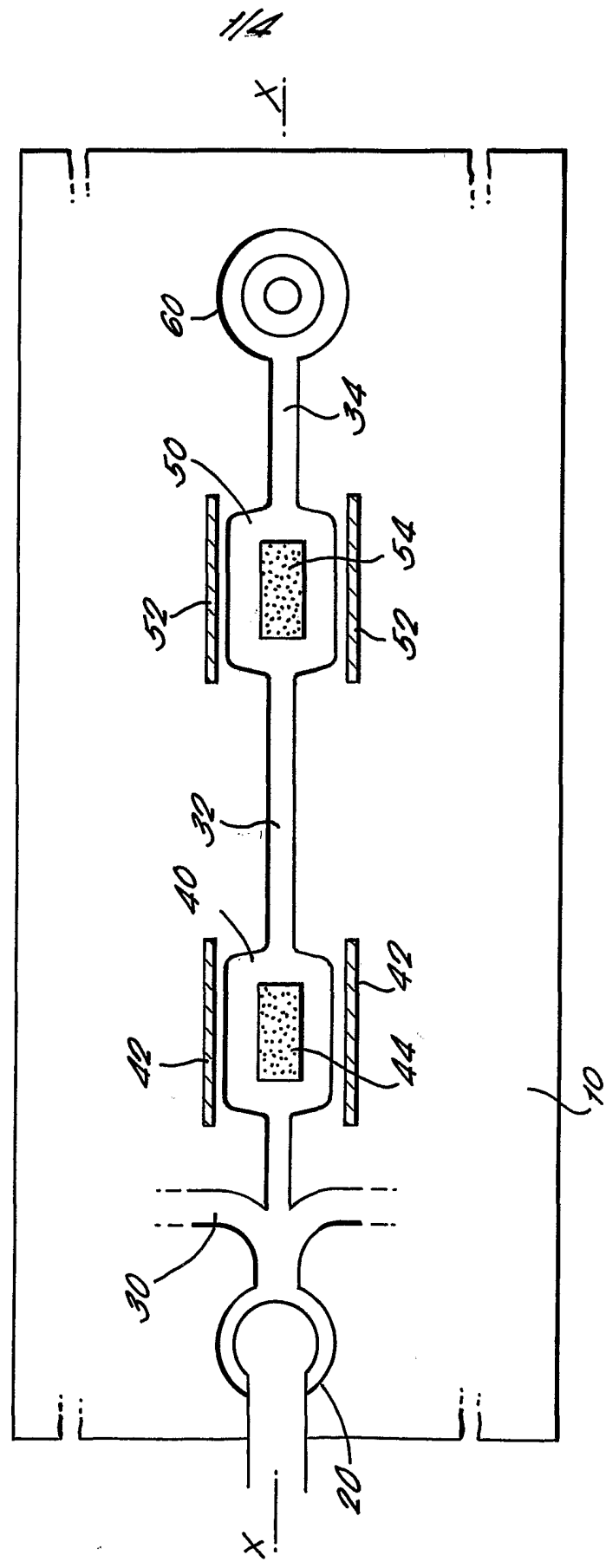

3/A

FIG. 3.

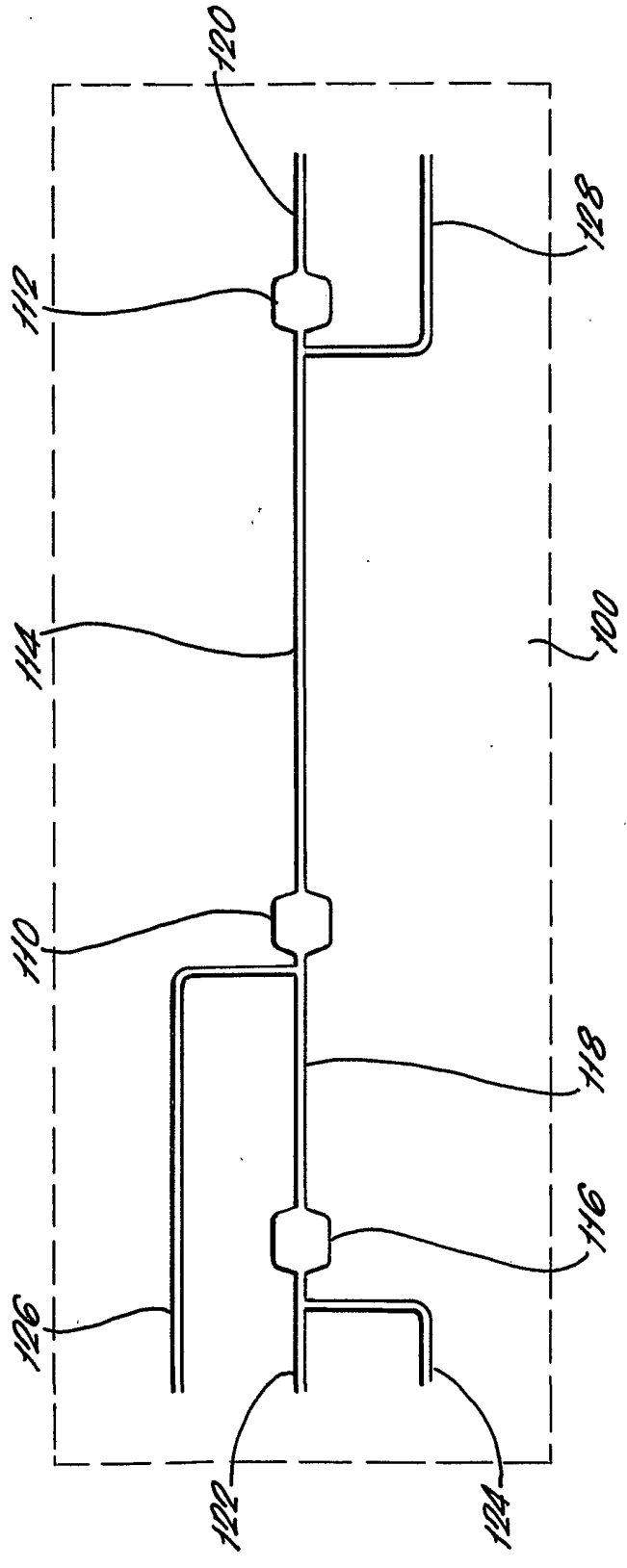

4/4

FIG. 4.

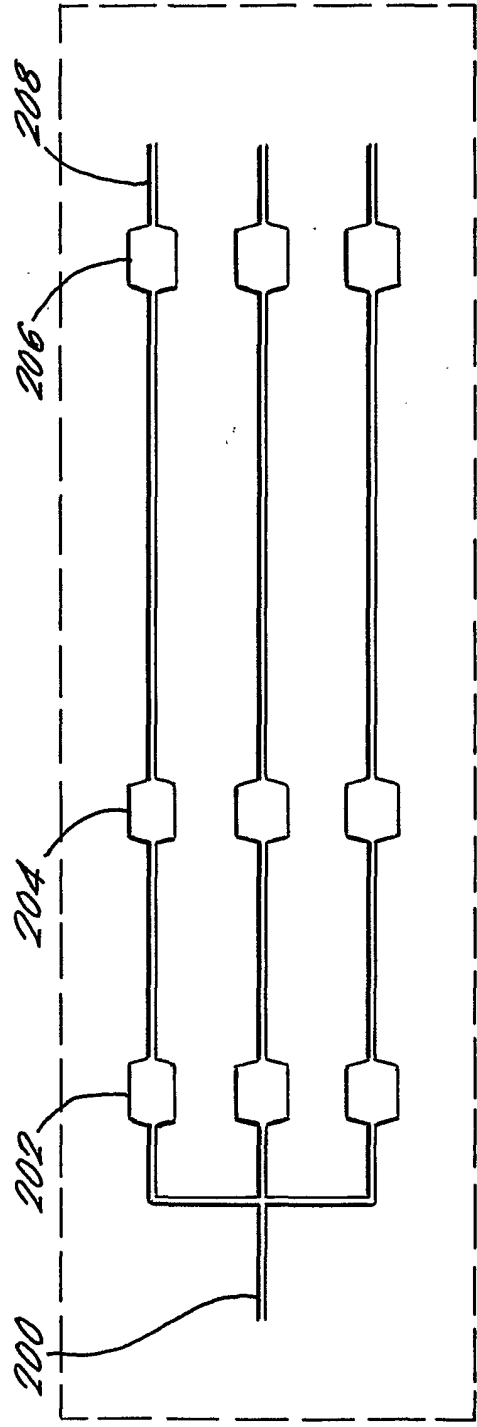

1
SEQUENCE LISTING

<110> NORCHIP A/S

<120> Microfabricated reaction chamber system

<130> SJA/RPS/55512/001

<160> 7

<170> PatentIn version 3.1

<210> 1

<211> 118

<212> DNA

<213> Artificial

<400> 1
gattagacat ttcagcatac gcataatcgg ccggcttcgc ctaggcatat cctttgcatg 60
ctactatatg ggacgatagc accaaatgcc agtcagatag cacagtagca gcgattaa 118

<210> 2

<211> 51

<212> DNA

<213> Artificial

<400> 2
aattctaata cgactcacta tagggagaag ggctgctact gtgctatctg a 51

<210> 3

<211> 20

<212> DNA

<213> Artificial

<400> 3
gacatttcag catacgcata 20

<210> 4

<211> 20

<212> DNA

<213> Artificial

<400> 4
atcctttgca tgctactata 20

<210> 5

<211> 51

<212> DNA

<213> Artificial

<400> 5
aattctaata cgactcacta tagggagaag gggattcagt gttactctct a 51

<210> 6
<211> 40
<212> DNA
<213> Artificial

<400> 6
gatgcaaggt cgcatatgag acaaaagacc cctcaagata 40

<210> 7
<211> 32
<212> DNA
<213> Artificial

<400> 7
ccgtcgtact gcccaacaac catctccgac gg 32

INTERNATIONAL SEARCH REPORT

Int'l Application No

PCT/GB 01/04145

A. CLASSIFICATION OF SUBJECT MATTER IPC 7 B01L3/00 //C12Q1/68		
According to International Patent Classification (IPC) or to both national classification and IPC		
B. FIELDS SEARCHED		
Minimum documentation searched (classification system followed by classification symbols) IPC 7 B01L C12Q G01N		
Documentation searched other than minimum documentation to the extent that such documents are included in the fields searched		
Electronic data base consulted during the international search (name of data base and, where practical, search terms used) EPO-Internal, WPI Data, PAJ, BIOSIS		
C. DOCUMENTS CONSIDERED TO BE RELEVANT		
Category °	Citation of document, with indication, where appropriate, of the relevant passages	Relevant to claim No.
X Y	US 5 922 591 A (FODOR STEPHEN P A ET AL) 13 July 1999 (1999-07-13) column 3, line 30 -column 3, line 47 column 7, line 37 -column 7, line 46 column 8, line 20 -column 8, line 54 column 11, line 15 -column 11, line 22 column 15, line 4 -column 15, line 19 column 17, line 23 -column 17, line 43 column 18, line 10 -column 18, line 64 column 19, line 29 -column 19, line 56 column 20, line 26 -column 20, line 40 column 20, line 59 -column 20, line 65 column 22, line 32 -column 24, line 19 column 26, line 15 -column 26, line 41 column 27, line 58 -column 29, line 46 column 30, line 26 -column 30, line 55 column 31, line 41 -column 31, line 65 column 33, line 22 -column 33, line 39 -/--	1-9, 14, 16-26 12, 27, 28
<input checked="" type="checkbox"/>	Further documents are listed in the continuation of box C.	<input checked="" type="checkbox"/>
° Special categories of cited documents : *A* document defining the general state of the art which is not considered to be of particular relevance *E* earlier document but published on or after the international filing date *L* document which may throw doubts on priority claim(s) or which is cited to establish the publication date of another citation or other special reason (as specified) *O* document referring to an oral disclosure, use, exhibition or other means *P* document published prior to the international filing date but later than the priority date claimed		*T* later document published after the international filing date or priority date and not in conflict with the application but cited to understand the principle or theory underlying the invention *X* document of particular relevance; the claimed invention cannot be considered novel or cannot be considered to involve an inventive step when the document is taken alone *Y* document of particular relevance; the claimed invention cannot be considered to involve an inventive step when the document is combined with one or more other such documents, such combination being obvious to a person skilled in the art. *&* document member of the same patent family
Date of the actual completion of the international search 25 January 2002		Date of mailing of the international search report 18/02/2002
Name and mailing address of the ISA European Patent Office, P.B. 5818 Patentlaan 2 NL - 2280 HV Rijswijk Tel. (+31-70) 340-2040, Tx. 31 651 epo nl, Fax: (+31-70) 340-3016		Authorized officer Koch, A

INTERNATIONAL SEARCH REPORT

ial Application No

PCT/JP 01/04145

C.(Continuation) DOCUMENTS CONSIDERED TO BE RELEVANT		
Category °	Citation of document, with indication, where appropriate, of the relevant passages	Relevant to claim No.
	<p>column 35, line 3 -column 36, line 20 column 37, line 47 -column 37, line 55 column 38, line 1 -column 38, line 8 column 38, line 29 -column 38, line 44 column 39, line 57 -column 40, line 23 column 41, line 25 -column 41, line 34 figures 3,6,12,13</p> <p style="text-align: center;">---</p>	
X	<p>US 5 783 148 A (COTTINGHAM HUGH V ET AL) 21 July 1998 (1998-07-21) column 3, line 45 -column 3, line 52 column 4, line 8 -column 4, line 65 column 5, line 5 -column 5, line 39 column 8, line 4 -column 9, line 15 column 10, line 30 -column 11, line 31 column 12, line 22 -column 12, line 60 column 13, line 6 -column 13, line 31 figures 1-12</p> <p style="text-align: center;">---</p>	1,3,21, 22,24-26
Y	<p>JACOBSON S C ET AL: "PRECOLUMN REACTIONS WITH ELECTROHORETIC ANALYSIS INTEGRATED ON A MICROCHIP" ANALYTICAL CHEMISTRY, AMERICAN CHEMICAL SOCIETY, COLUMBUS, US, vol. 66, no. 23, 1 December 1994 (1994-12-01), pages 4127-4132, XP000485686 ISSN: 0003-2700 cited in the application page 4127, column 2, paragraph 3 -page 4128, column 2, line 9</p> <p style="text-align: center;">---</p>	12
Y	<p>LEONE GIONATA ET AL: "Molecular beacon probes combined with amplification by NASBA enable homogeneous, real-time detection of RNA" NUCLEIC ACIDS RESEARCH, vol. 26, no. 9, 1998, pages 2150-2155, XP002188324 cited in the application page 2150, column 1, line 9 -page 2150, column 2, line 20 page 2151, column 1, paragraph 6 -page 2151, column 2, line 12</p> <p style="text-align: center;">---</p>	27
	-/--	

INTERNATIONAL SEARCH REPORT

Int. Patent Application No

PCT/GB 01/04145

C.(Continuation) DOCUMENTS CONSIDERED TO BE RELEVANT		
Category °	Citation of document, with indication, where appropriate, of the relevant passages	Relevant to claim No.
Y	<p>COMPTON J: "NUCLEIC ACID SEQUENCE-BASED AMPLIFICATION" NATURE, MACMILLAN JOURNALS LTD. LONDON, GB, vol. 350, no. 6313, 7 March 1991 (1991-03-07), pages 91-92, XP000176319 ISSN: 0028-0836 cited in the application page 350, column 1, paragraph 3 -page 350, column 2, paragraph 2 -----</p>	28

INTERNATIONAL SEARCH REPORT

 International Application No
 PCT/GB 01/04145

Patent document cited in search report		Publication date	Patent family member(s)	Publication date
US 5922591	A	13-07-1999	US 5856174 A	05-01-1999
			US 6168948 B1	02-01-2001
			US 6197595 B1	06-03-2001
			US 6326211 B1	04-12-2001
			US 2001036672 A1	01-11-2001
			AU 6404996 A	05-02-1997
			EP 0843734 A1	27-05-1998
			JP 11509094 T	17-08-1999
			WO 9702357 A1	23-01-1997
			US 6043080 A	28-03-2000
<hr/>				
US 5783148	A	21-07-1998	AU 689187 B2	26-03-1998
			AU 1352595 A	21-09-1995
			BR 9501042 A	31-10-1995
			CA 2143365 A1	15-09-1995
			EP 0674009 A2	27-09-1995
			JP 2675989 B2	12-11-1997
			JP 7265100 A	17-10-1995
			SG 30306 A1	01-06-1996
			US 5725831 A	10-03-1998
<hr/>				