

**(12) STANDARD PATENT**  
**(19) AUSTRALIAN PATENT OFFICE**

(11) Application No. **AU 2004203562 B2**

(54) Title  
**A Stent**

(51) International Patent Classification(s)  
**A61M 29/00** (2006.01)

(21) Application No: **2004203562**

(22) Date of Filing: **2004.08.02**

(43) Publication Date: **2004.08.26**

(43) Publication Journal Date: **2004.08.26**

(44) Accepted Journal Date: **2006.08.31**

(62) Divisional of:  
**18714/02**

(71) Applicant(s)  
**Medinol Ltd**

(72) Inventor(s)  
**Israel, Henry M.;Pinchasik, Gregory**

(74) Agent / Attorney  
**Davies Collison Cave, 1 Nicholson Street, MELBOURNE, VIC, 3000**

(56) Related Art  
**EP 566807**  
**EP 335341**  
**EP 606165**

ABSTRACT

A cylindrical stent, comprising:

- 5 a) a plurality of odd and even alternating circumferential meanders, each substantially equally spaced from the next and each having alternate oppositely facing first areas of inflection, wherein the odd meanders are out of phase from the even meanders such that alternate first
- 10 areas of inflection on the odd meanders are adjacent oppositely facing alternate first areas of inflection of the even meanders; and
- b) means connecting the odd and even meanders comprising a plurality of flexible links connecting adjacent
- 15 first areas of inflection of adjacent even and odd meanders, wherein each flexible link has at least two portions connected by at least one second area of inflection and wherein the first areas of inflection define a series of identical first bends and the second areas of inflection
- 20 define a series of identical second bends; and wherein the bisecting lines of the first bends are at angles to the bisecting lines of the second bends.

**A U S T R A L I A**  
**Patents Act 1990**  
COMPLETE SPECIFICATION  
FOR A STANDARD PATENT  
(ORIGINAL)

---

Name of Applicant: **MEDINOL LTD.**, of Kiryat Atidim, P.O. Box 58165, 61581  
Tel Aviv , ISRAEL

Actual Inventors: ISRAEL, Henry, M.  
PINCHASIK, Gregory

Address for Service: **DAVIES COLLISON CAVE**, Patent Attorneys,  
of 1 Nicholson Street, Melbourne 3000, Victoria, Australia

Invention Title: **A Stent**

The following statement is a full description of this invention, including the best method of performing it known to us:

A STENT

5

FIELD OF THE INVENTION

The present invention relates generally to stents for implanting into a living body.

10

BACKGROUND OF THE INVENTION

Various stents are known in the art wherein, for the present application, the term "stent" indicates a device, made of body-compatible material, which is utilized to widen a blood vessel, or other orifice in the body, and to maintain the resultant size of the lumen. Typically, the stent is delivered to the desired location in the body with an inflatable balloon and, when the balloon is inflated, the stent expands, thereby widening the orifice. Other mechanical devices which cause expansion of the stent are also utilized.

Exemplary patents in the field of stents formed of wire are: U.S. 5,019,090 to Pinchuk, U.S. 5,161,547 to Tower, U.S. 4,950,227 to Savin, et al., U.S. 5,314,472 to Fontaine, U.S. 4,886,062 and U.S. 4,969,458 to Wiktor and U.S. 4,856,516 to Hillstead. Stents formed of cut stock metal are described in: U.S. 4,733,665 to Palmaz, U.S. 4,762,128 to Rosenbluth, U.S. 5,102,417 to Palmaz and Schatz, U.S. 5,195,984 to Schatz and WO 91 FR013820 to Meadox.

30

The stents described in U.S. 5,102,417 to Palmaz and Schatz have expandable tubular grafts connected together with a flexible connector. The grafts are formed of a plurality of slots disposed parallel to the longitudinal axis of the tube. The flexible connectors are helical connectors. Since the tubular grafts are relatively rigid, the flexible connectors are needed so that the stents can bend when being fed through a curved blood vessel. When the stents of U.S. 5,102,417

35

expand, the grafts expand radially and, consequently, shrink longitudinally. However, at the same time, the helical connectors twist. The twisting motion is most probably harmful to the blood vessel.

5 U.S. 5,195,984 to Schatz describes a similar stent but with one straight connector, parallel to the longitudinal axis of the tubular grafts, between tubular grafts. The straight member removes the twisting motion; however, it is not a very strong connector.

10

#### SUMMARY OF THE PRESENT INVENTION

An object of the present invention is to provide a cylindrical stent, comprising:

a) a plurality of odd and even alternating  
15 circumferential meanders, each substantially equally spaced from the next and each having alternate oppositely facing first areas of inflection, wherein the odd meanders are out of phase from the even meanders such that alternate first areas of inflection on the odd meanders are adjacent  
20 oppositely facing alternate first areas of inflection of the even meanders; and

b) means connecting the odd and even meanders comprising a plurality of flexible links connecting adjacent first areas of inflection of adjacent even and odd meanders,  
25 wherein each flexible link has at least two portions connected by at least one second area of inflection and wherein the first areas of inflection define a series of identical first bends and the second areas of inflection define a series of identical second bends; and wherein the  
30 bisecting lines of the first bends are at angles to the bisecting lines of the second bends.

The invention also provides a stent comprising:

2004203562 18 Aug 2006

- 4 -

a) at least odd and even alternating serpentine sections, each having first areas of inflection, wherein said odd serpentine section is out of phase from said even serpentine section such that first areas of inflection of  
5 said odd serpentine section are adjacent first areas of inflection on said even serpentine section; and

b) at least one flexible connector, comprising a plurality of flexible links connecting adjacent first areas of inflection of adjacent even and odd serpentine sections;  
10 wherein each flexible link has at least two portions connected by at least one second area of inflection define first and second angles whose bisecting lines are at angles one to another.

15

20

25

## BRIEF DESCRIPTION OF THE DRAWINGS

The present invention will be understood and  
5 appreciated more fully from the following detailed  
description taken in conjunction with the drawings in which:

Fig. 1 is an illustration of a patterned stent,  
constructed and operative in accordance with a first  
preferred embodiment of the present invention;

10 Fig. 2 is an illustration of the pattern of the stent  
of Fig. 1;

Fig. 3 is an illustration of the stent of Fig. 1 in a  
bent position;

15 Fig. 4 is an illustration of the stent of Fig. 1 in an  
expanded format;

Figs. 5A and 5B are illustrations of the changes in the  
patterns of the stent of Fig. 1 due to expansion;

Fig. 6 is a schematic illustration of a second  
embodiment of the pattern for a stent;

20 Fig. 7 is an illustration of a third embodiment of the  
pattern for the stent; and

Fig. 8 is an illustration of the pattern of Fig. 7 in an expanded format.

DETAILED DESCRIPTION OF PREFERRED EMBODIMENTS

5 Reference is now made to Figs. 1 - 4 which illustrate a first embodiment of a stent, constructed and operative in accordance with the principles of the present invention. Fig. 1 illustrates the stent in its non-expanded form, Fig. 2 illustrates the pattern of  
10 the stent, Fig. 3 illustrates it in a partially bent position and Fig. 4 illustrates it in an expanded form.

The stent of the present invention is a tube whose sides are formed into a plurality of each of two  
15 orthogonal meander patterns which patterns are intertwined with each other. The term "meander pattern" is taken herein to describe a periodic pattern about a center line and "orthogonal meander patterns" are patterns whose center lines are orthogonal to each other.

20 In the stent of Figs. 1 - 4, the two meander patterns are labeled 11 and 12 and they are most easily seen in Fig. 2. Meander pattern 11 is a vertical sinusoid having a vertical center line 9. Meander pattern 11 has two loops 14 and 16 per period wherein  
25 loops 14 open to the right while loops 16 open to the left. Loops 14 and 16 share common members 15 and 17, where member 15 connects from one loop 14 to its following loop 16 and member 17 connects from one loop 16 to its following loop 14.

30 Meander pattern 12 is an horizontal pattern having an horizontal center line 13. Meander pattern 12 also has loops, labeled 18 and 20, but between loops of a period is an extended straight section labeled 22. Loops 18 open downwards and loops 20 open upwards.  
35 Vertical meander pattern 11 is provided in odd and even (o and e) versions which are 180° out of phase with



each other. Thus, each left opening loop 16 of meander pattern 11o faces a right opening loop 14 of meander pattern 11e and a right opening loop 14 of meander pattern 11o faces a left opening loop 16 of meander pattern 11e.

Horizontal meander pattern 12 is also provided in odd and even forms. The straight sections 22 of horizontal meander pattern 12e intersect with every third common member 17 of vertical meander pattern 11e. The straight sections 22 of horizontal meander pattern 12o intersect with every third common member 15 of vertical meander pattern 11e. beginning with the common member 15 two after an intersected common member 17. The result is a full loop 14 between meander patterns 12e and 12o and a full loop 16 between meander patterns 12o and 12e.

Returning to Fig. 1, the pattern of Fig. 2 is formed into a tube 30 of an easily deformable material, such as a metal. Due to the two meander patterns, the stent of Fig. 1, when attached over a catheter balloon, is flexible and can therefore be easily dragged through curved blood vessels. An example of the way in which the stent of Fig. 1 bends is illustrated in Fig. 3.

In Fig. 3, the stent begins to bend at the point marked A in the direction marked by arrow 40. As the stent begins to curve, the section marked I becomes the inside of the curve while the section marked O becomes the outside of the curve. The inside of the curve I is shortened vis-a-vis the outside of the curve O.

During bending, the loops 14 - 20 to the right of the point A change shape in order to compensate for the differences in length between the inside and outside curves. For example, loops 18i and 20i near the inside of the curve are closer together than loops 18o and 20o on the outside of the curve, which expand. Loops 14i and 16i near the inside I are compressed while the

loops 140 and 160 closer to the outside O of the curve are expanded.

As can be seen, both meander patterns 11 and 12 are involved in the bending. Although not shown, it will be appreciated that the stent of Figs. 1 - 4 can bend in any direction and in more than one direction at any time.

Fig. 4 illustrates the stent of Fig. 1 in its expanded form. When the stent expands, both meander patterns 11 and 12 expand (i.e. all loops 14 - 20 open up). As can be seen, the expanded stent has two types of enclosed spaces, a large space 42 between meander patterns 120 and 12e and a small space 44 between meander patterns 12e and 12o. As can also be seen, each large space 42 has two loops 14 on its left side and two loops 16 on its right side. The large spaces between vertical meander patterns 11e and 11o, which are labeled 42a, have loops 18 at their tops and bottoms while the large spaces between vertical meander patterns 11o and 11e, which are labeled 42b, have loops 20 at their tops and bottoms. Similarly for small spaces 44a and 44b.

It is noted that, due to the orthogonal meander patterns 11 and 12, the stent of Fig. 1 does not significantly shrink during expansion. This is illustrated in detail in Figs. 5A and 5B to which reference is now made. Fig. 5A illustrates the movement, during expansion, of one vertical meander pattern 11 and Fig. 5B illustrates the movement, during expansion, of one horizontal meander pattern 12. The original patterns are shown with solid lines and the expanded patterns are shown with dashed lines.

The vertical meander pattern 11 of Fig. 5A expands by widening its loops 14 and 16. As a result, the vertical meander pattern 11 grows vertically by an amount  $2 \cdot h_1$ , per loop. However, it also shrinks

horizontally, by an amount  $2*d_1$ . Similarly, the horizontal meander pattern 12 of Fig. 5B expands by widening its loops 18 and 20. As a result, the horizontal meander pattern 12 grows horizontally by an amount  $2*d_2$  per loop. However, it also shrinks vertically, by an amount  $h_2$ . Thus, the vertical growth of the vertical meander pattern 11 compensates, at least partially, for the vertical shrinkage of the horizontal meander pattern 12, and vice versa. It is noted that the end portions of any stent are only partially compensated and therefore, may shrink somewhat.

It will be appreciated that the two orthogonal meander patterns 11 and 12 and the compensation they provide to each other provides flexibility to the unexpanded stent of Fig. 1. However, when the stent is expanded, the changes in each of loops 14 and 16 provide rigidity to the resultant stent and thus, enable the stent to maintain a blood vessel at a desired inner diameter.

The stent of the present invention can be manufactured from flat metal which is etched into the pattern of Fig. 2. The etched metal is then bent to form the tube 30. Alternatively, the pattern of Fig. 2 can be manufactured from welded or twisted wire.

It will be appreciated that the stent of the present invention can be made from metal and/or wire. Additionally, it can be plated with a protective material, embedded with a medicine, and/or covered with a material which can fill in the spaces 42 and 44.

It will be appreciated that the present invention encompasses all stents manufactured with a pattern formed of two meander patterns, orthogonal or otherwise. Another exemplary pattern, also with orthogonal meander patterns, is provided herein wherein Fig. 6 is a schematic version and Fig. 7 is a more

rounded version. Fig. 8 shows the pattern of Fig. 7 in an expanded format. The pattern of Figs. 6 and 7 is similar to that shown in Fig. 2 except that it has more horizontal meander patterns 12 and they are of one kind, rather than  
5 being even and odd as in Fig. 2.

As can be seen in both Figs. 6 and 7, there are two types of vertical meander patterns 11e and 11o which are 180° out of phase with each other. The horizontal meander patterns 12 connect with every line 15 of vertical meander  
10 pattern 11e.

Fig. 8 illustrates the pattern of Fig. 7 in an expanded format. Since there are no even and odd horizontal meander patterns, in the expanded format of Fig. 8, there are no large and small spaces. Instead, all spaces are of the same  
15 size.

It will be appreciated by persons skilled in the art that the present invention is not limited to what has been particularly shown and described hereinabove. Rather, the scope of the present invention is defined by the claims  
20 which follow.

The reference to any prior art in this specification is not, and should not be taken as, an acknowledgment or any form of suggestion that that prior art forms part of the common general knowledge in Australia.

25 Throughout this specification and the claims which follow, unless the context requires otherwise, the word "comprise", and variations such as "comprises" and "comprising", will be understood to imply the inclusion of a stated integer or step or group of integers or steps but not  
30 the exclusion of any other integer or step or group of integers or steps.

THE CLAIMS DEFINING THE INVENTION ARE AS FOLLOWS:

1. A cylindrical stent, comprising:
  - a) a plurality of odd and even alternating  
5 circumferential meanders, each substantially equally spaced  
from the next and each having alternate oppositely facing  
first areas of inflection, wherein the odd meanders are out  
of phase from the even meanders such that alternate first  
areas of inflection on the odd meanders are adjacent  
10 oppositely facing alternate first areas of inflection of the  
even meanders; and
  - b) means connecting the odd and even meanders  
comprising a plurality of flexible links connecting adjacent  
15 first areas of inflection of adjacent even and odd meanders,  
wherein each flexible link has at least two portions  
connected by at least one second area of inflection and  
wherein the first areas of inflection define a series of  
identical first bends and the second areas of inflection  
define a series of identical second bends; and wherein the  
20 bisecting lines of the first bends are at angles to the  
bisecting lines of the second bends.
2. A stent according to claim 1 wherein the meanders  
25 extend in the circumferential direction of the stent such  
that the bisecting lines of the first areas of inflection  
extend in the axial direction of the stent.
3. A stent according to claim 2 wherein the bisecting  
30 lines of the second areas of inflection extend in the  
circumferential direction of the stent.

2004203562 18 Aug 2006

- 12 -

4. A stent according to claim 3 wherein a flexible link connects each pair of adjacent first areas of inflection.

5 5. A stent according to claim 4 wherein the meanders and flexible links of the stent define a plurality of enclosed spaces, each enclosed space being defined by two first areas of inflection alternating with two flexible links.

6. A stent comprising:

10 a) at least odd and even alternating serpentine sections, each having first areas of inflection, wherein said odd serpentine section is out of phase from said even serpentine section such that first areas of inflection of said odd serpentine section are adjacent first areas of  
15 inflection on said even serpentine section; and

b) at least one flexible connector, comprising a plurality of flexible links connecting adjacent first areas of inflection of adjacent even and odd serpentine sections; wherein each flexible link has at least two portions  
20 connected by at least one second area of inflection define first and second angles whose bisecting lines are at angles one to another.

9. A stent substantially as hereinbefore described with  
25 reference to the accompanying drawings.

DATED this 17th day of August, 2006

30 **MEDINOL LTD.**

By its Patent Attorneys  
DAVIES COLLISON CAVE

FIG. 1

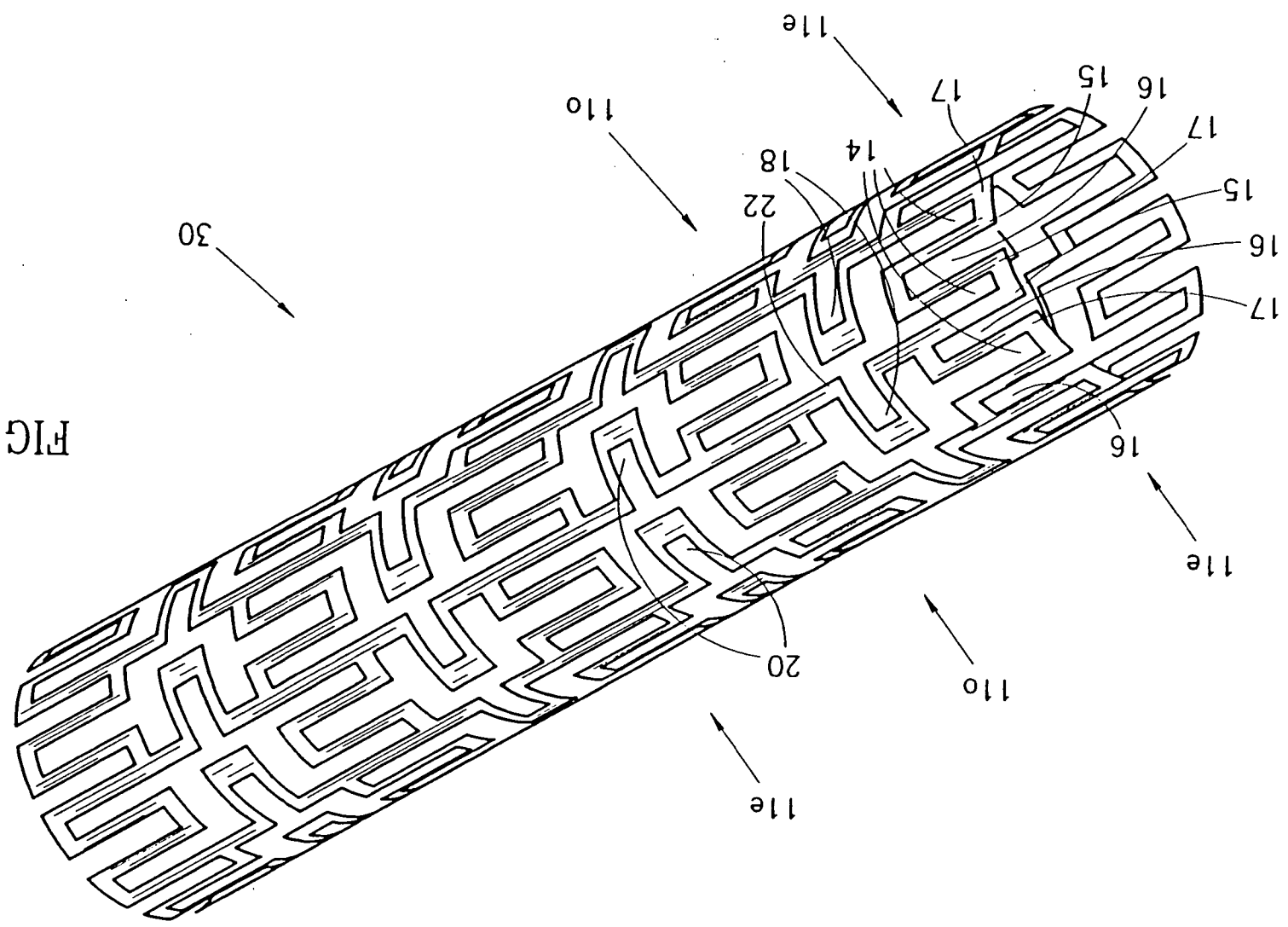

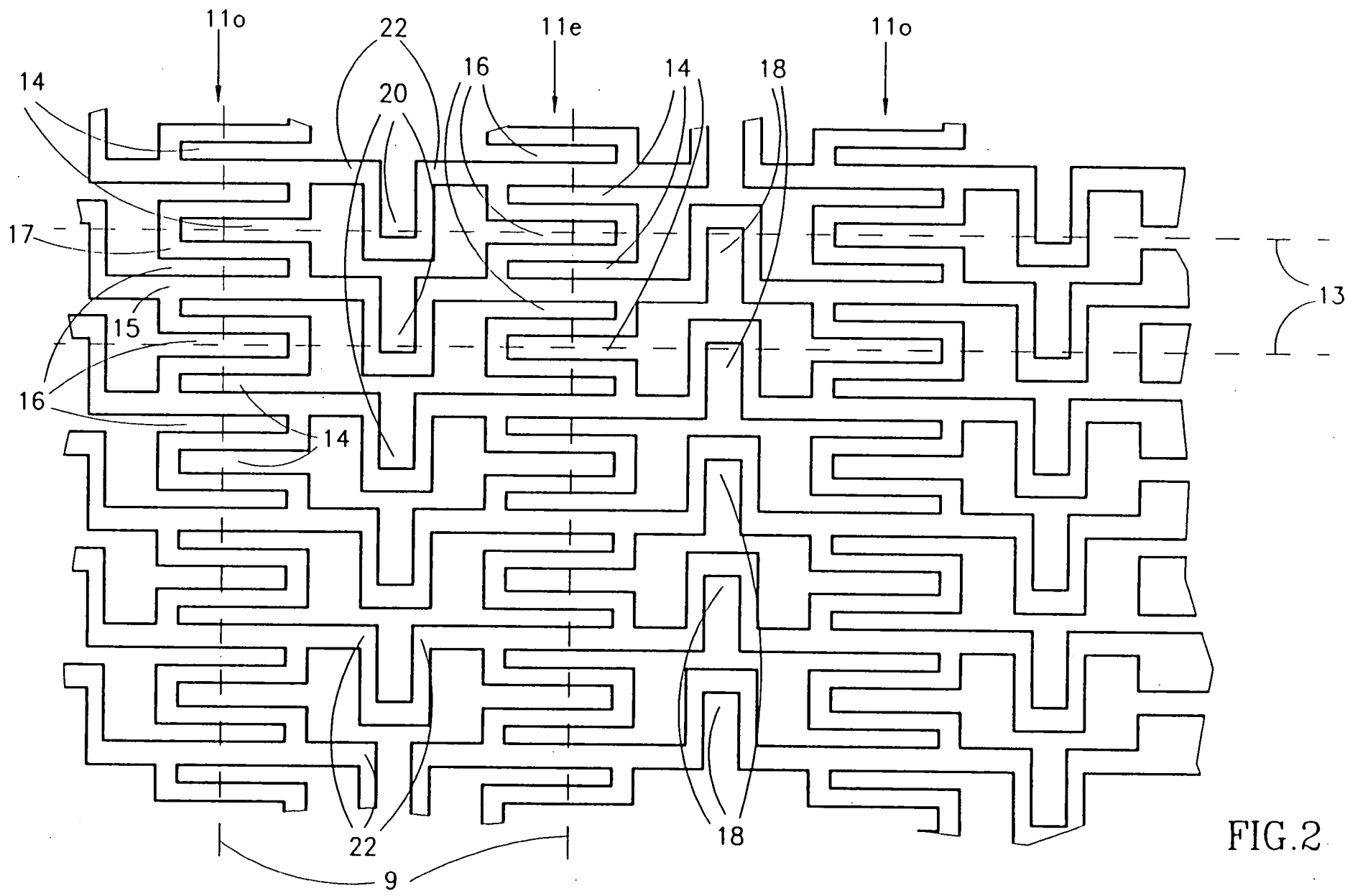
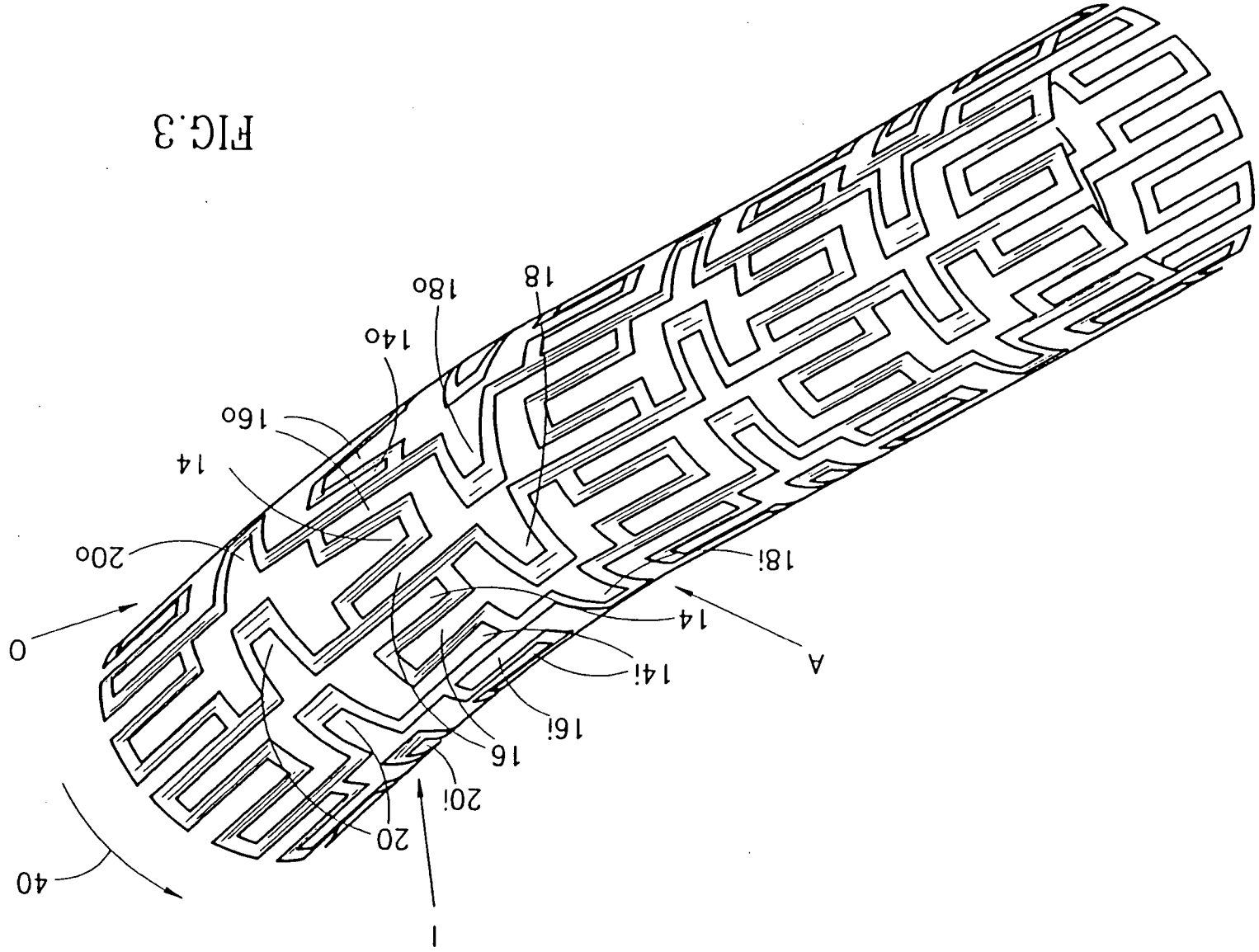

FIG.2



FIG. 3





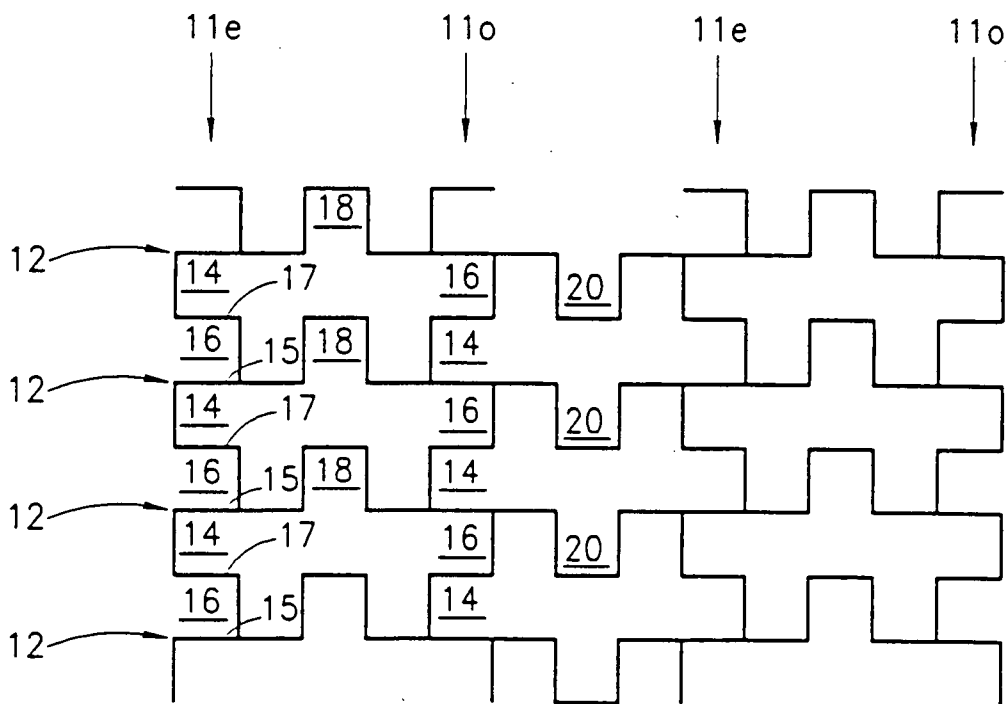
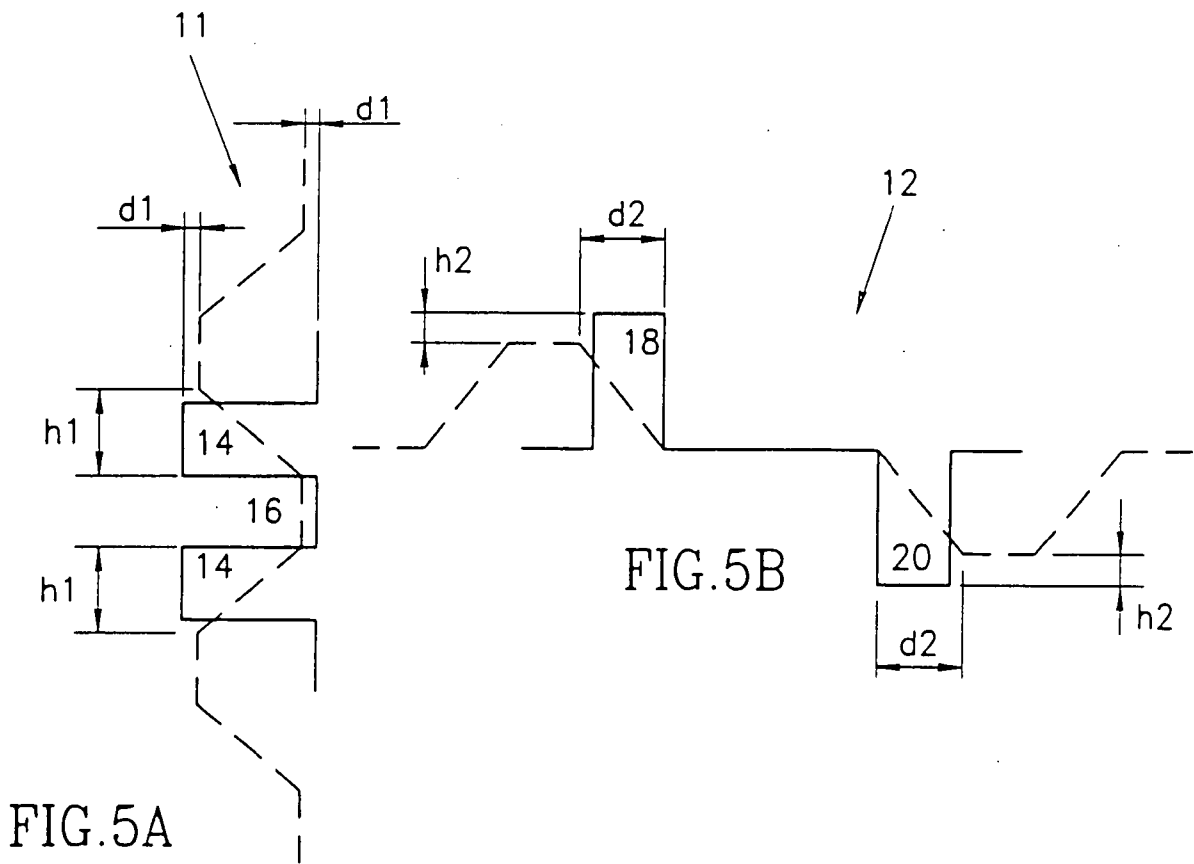

FIG. 6

FIG. 8

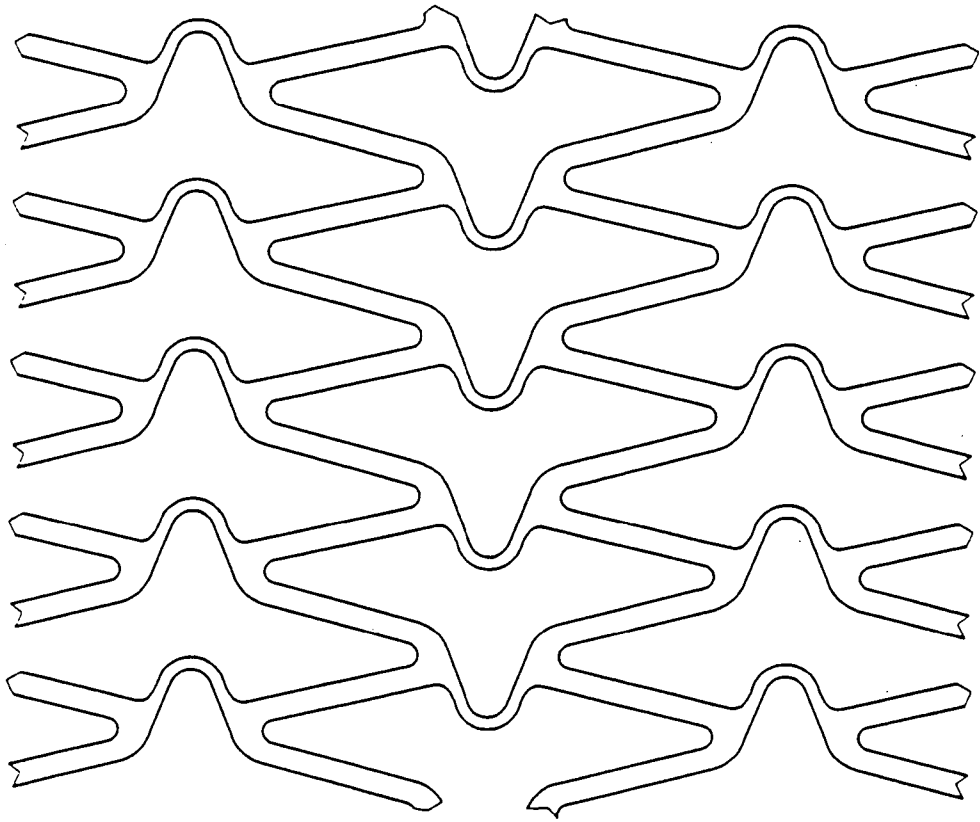

FIG. 7

