



US012125384B2

(12) **United States Patent**  
**Sweeney**

(10) **Patent No.:** **US 12,125,384 B2**

(45) **Date of Patent:** **\*Oct. 22, 2024**

(54) **TARGET ADDRESSING SYSTEM**

(71) Applicant: **Uber Technologies, Inc.**, San Francisco, CA (US)

(72) Inventor: **Matthew Sweeney**, Pittsburgh, PA (US)

(73) Assignee: **Uber Technologies, Inc.**, San Francisco, CA (US)

(\*) Notice: Subject to any disclaimer, the term of this patent is extended or adjusted under 35 U.S.C. 154(b) by 0 days.

This patent is subject to a terminal disclaimer.

(21) Appl. No.: **18/213,712**

(22) Filed: **Jun. 23, 2023**

(65) **Prior Publication Data**

US 2023/0334988 A1 Oct. 19, 2023

**Related U.S. Application Data**

(63) Continuation of application No. 17/592,392, filed on Feb. 3, 2022, now Pat. No. 11,741,838, which is a (Continued)

(51) **Int. Cl.**  
**G08G 1/14** (2006.01)  
**G08G 1/00** (2006.01)  
(Continued)

(52) **U.S. Cl.**  
CPC ..... **G08G 1/146** (2013.01); **G08G 1/005** (2013.01); **G08G 1/143** (2013.01); **G08G 1/147** (2013.01);  
(Continued)

(58) **Field of Classification Search**

CPC ..... G08G 1/146; G08G 1/005; G08G 1/143; G08G 1/147; G08G 1/148; G08G 1/202; H04W 4/029; H04W 88/02; H04W 4/02  
See application file for complete search history.

(56) **References Cited**

U.S. PATENT DOCUMENTS

6,587,782 B1 7/2003 Nocek et al.  
6,608,566 B1 8/2003 Davis  
(Continued)

FOREIGN PATENT DOCUMENTS

CA 2604321 10/2006  
CA 2975002 8/2016  
(Continued)

OTHER PUBLICATIONS

Yuan, et al., T-Finder: A recommender System for Finding Passengers and Vacant Taxis, IEEE 2013.  
(Continued)

*Primary Examiner* — Santiago Garcia

(74) *Attorney, Agent, or Firm* — Mahamedi IP Law LLP

(57) **ABSTRACT**

A computing system can receive a request for a service from a computing device of a given user of the network service, and select an entrance from multiple entrances for a geographic area associated with the request for the service. The system may then determine a sequence of instructions for a driver of a vehicle to fulfill the request, where the sequence of instructions includes at least (i) an instruction to enter the geographic area at the selected entrance, and (ii) a vehicle stopping location. The system then transmits the sequence of instructions to a computing device of the driver.

**20 Claims, 7 Drawing Sheets**

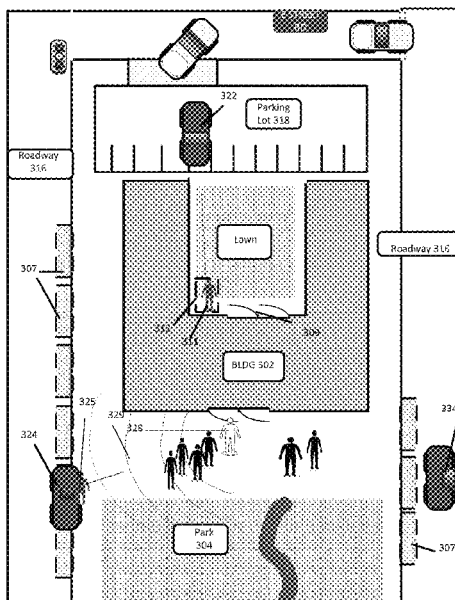

**Related U.S. Application Data**

continuation of application No. 15/930,223, filed on May 12, 2020, now Pat. No. 11,263,905, which is a continuation of application No. 16/118,916, filed on Aug. 31, 2018, now Pat. No. 10,720,056, which is a continuation of application No. 15/465,003, filed on Mar. 21, 2017, now Pat. No. 10,115,308.

(60) Provisional application No. 62/311,339, filed on Mar. 21, 2016.

(51) **Int. Cl.**

**G08G 1/005** (2006.01)  
**H04W 4/029** (2018.01)  
**H04W 88/02** (2009.01)

(52) **U.S. Cl.**

CPC ..... **G08G 1/148** (2013.01); **G08G 1/202** (2013.01); **H04W 4/029** (2018.02); **H04W 88/02** (2013.01)

(56)

**References Cited**

U.S. PATENT DOCUMENTS

6,668,177	B2	12/2003	Salmimaa	
6,756,913	B1	6/2004	Ayed	
7,353,034	B2	4/2008	Haney	
7,606,663	B2	10/2009	Neef	
7,886,019	B2	2/2011	Srinivasachar	
7,970,749	B2	6/2011	Uhlir	
8,412,667	B2	4/2013	Zhang	
8,538,956	B1	9/2013	Szabadka	
8,630,897	B1*	1/2014	Prada Gomez	..... G08G 1/202 705/14.57
8,630,987	B2	1/2014	Prada Gomez	
8,775,070	B1	7/2014	Bhatia	
8,902,260	B2	12/2014	Kuhne	
9,070,101	B2	6/2015	Abhayanker	
9,244,147	B1*	1/2016	Soundararajan	..... G01S 1/44
9,631,933	B1	4/2017	Aula	
9,911,170	B2	3/2018	Kim	
10,074,065	B2	9/2018	Jones	
10,082,793	B1	9/2018	Glaser	
10,152,053	B1	12/2018	Smith	
10,178,890	B1	1/2019	Andon	
10,203,212	B2	2/2019	Mazzella	
10,467,561	B2	11/2019	Haparnas	
10,535,271	B1	1/2020	Dyer	
10,572,964	B2	2/2020	Kim	
11,153,395	B2	10/2021	Sweeney	
11,622,018	B2	4/2023	Sweeney	
2002/0034292	A1	3/2002	Tuoriniemi	
2002/0054082	A1	5/2002	Karpf	
2002/0099599	A1	7/2002	Minassian	
2003/0058082	A1	3/2003	Mallick	
2004/0158483	A1	8/2004	Lecouturier	
2005/0177799	A1	8/2005	Knight	
2006/0023569	A1	2/2006	Agullo	
2006/0059023	A1	3/2006	Mashinsky	
2006/0080188	A1	4/2006	Jung	
2006/0155460	A1	7/2006	Raney	
2007/0038529	A1	2/2007	Jung	
2007/0150375	A1*	6/2007	Yang	..... G06Q 10/08 705/26.81
2008/0014908	A1	1/2008	Vasant	
2008/0027772	A1	1/2008	Gernega	
2008/0033633	A1	2/2008	Akiyoshi	
2008/0270019	A1	10/2008	Anderson	
2008/0277183	A1	11/2008	Huang	
2008/0319644	A1	12/2008	Zehler	
2009/0005963	A1	1/2009	Jarvinen	
2009/0113296	A1	4/2009	Lacy et al.	
2009/0119006	A1	5/2009	Silver	
2009/0150514	A1	6/2009	Davis	
2009/0156241	A1	6/2009	Staffaroni et al.	

2009/0171939	A1	7/2009	Athsani	
2009/0216600	A1	8/2009	Hill	
2009/0222482	A1	9/2009	Klassen	
2009/0248587	A1	10/2009	Van Buskirk	
2009/0296990	A1*	12/2009	Holland	..... G06T 7/60 382/106
2010/0070168	A1	3/2010	Sumcad	
2010/0074383	A1	3/2010	Lee	
2010/0179750	A1	7/2010	Gum	
2010/0223065	A1	9/2010	Jung	
2010/0253542	A1	10/2010	Seder	
2011/0052042	A1	3/2011	Ben Tzvi	
2011/0081919	A1	4/2011	Das et al.	
2011/0099040	A1	4/2011	Felt	
2011/0238289	A1	9/2011	Lehmann	
2011/0238755	A1	9/2011	Khan	
2011/0246246	A1	10/2011	Johnson	
2012/0023294	A1	1/2012	Resnick	
2012/0041675	A1	2/2012	Juliver	
2012/0158445	A1	6/2012	Dufford	
2012/0233246	A1	9/2012	Guernez	
2012/0239452	A1	9/2012	Trivedi	
2012/0253548	A1	10/2012	Davidson	
2012/0265580	A1	10/2012	Kobayashi	
2012/0290337	A1	11/2012	Helmy	
2012/0290950	A1	11/2012	Rapaport	
2013/0054281	A1	2/2013	Thakkar	
2013/0096813	A1	4/2013	Geffner	
2013/0110392	A1	5/2013	Kosseifi	
2013/0132140	A1	5/2013	Amin	
2013/0144831	A1	6/2013	Atlas	
2013/0174076	A1	7/2013	Geelen	
2013/0196692	A1	8/2013	Huang	
2013/0215843	A1	8/2013	Diachina	
2013/0218455	A1	8/2013	Clark	
2013/0226365	A1	8/2013	Brozovich	
2013/0232169	A1	9/2013	Gill et al.	
2013/0285855	A1	10/2013	Dupray	
2014/0012909	A1	1/2014	Sankar	
2014/0067901	A1	3/2014	Shaw	
2014/0074536	A1	3/2014	Meushar	
2014/0095221	A1	4/2014	Lore	
2014/0129951	A1	5/2014	Amin	
2014/0149441	A1	5/2014	Wang	
2014/0173511	A1	6/2014	Lehmann	
2014/0195972	A1	7/2014	Lee	
2014/0207375	A1	7/2014	Lerenc	
2014/0364150	A1	12/2014	Marti	
2014/0378159	A1	12/2014	Dolbakian	
2015/0055178	A1	2/2015	Ishibashi	
2015/0073645	A1	3/2015	Davidsson	
2015/0081581	A1	3/2015	Gishen	
2015/0100238	A1	4/2015	Cai	
2015/0154810	A1	6/2015	Tew	
2015/0161564	A1	6/2015	Sweeney	
2015/0161698	A1	6/2015	Jones	
2015/0254581	A1	9/2015	Brahme	
2015/0262430	A1	9/2015	Farrelly	
2015/0294238	A1	10/2015	Benque	
2015/0323327	A1	11/2015	Lord	
2015/0323330	A1	11/2015	Lord	
2015/0323331	A1	11/2015	Lord	
2015/0339923	A1	11/2015	Konig	
2015/0339928	A1*	11/2015	Ramanujam	..... G06Q 10/00 701/23
2015/0352128	A1	11/2015	Villa et al.	
2015/0371157	A1	12/2015	Jaffe	
2015/0379437	A1	12/2015	Reich	
2016/0013987	A1	1/2016	George	
2016/0014561	A1	1/2016	Inzer	
2016/0019496	A1	1/2016	Gorlin	
2016/0026935	A1	1/2016	Botea	
2016/0026936	A1	1/2016	Richardson	
2016/0034845	A1	2/2016	Hiyama	
2016/0055605	A1	2/2016	Kim	
2016/0132792	A1	5/2016	Rosnow	
2016/0191637	A1	6/2016	Memon	
2016/0231129	A1	8/2016	Erez	
2016/0301698	A1	10/2016	Katara	

(56)

References Cited

U.S. PATENT DOCUMENTS

2016/0314511 A1 10/2016 Jung  
 2016/0321771 A1 11/2016 Liu  
 2016/0363458 A1 12/2016 Guo  
 2016/0364678 A1 12/2016 Cao  
 2016/0364679 A1 12/2016 Cao  
 2016/0364812 A1 12/2016 Cao  
 2016/0364823 A1 12/2016 Cao  
 2016/0370194 A1 12/2016 Colijn  
 2017/0012920 A1 1/2017 Chheda  
 2017/0013408 A1 1/2017 Grzywaczewski  
 2017/0083832 A1 3/2017 Williams  
 2017/0087915 A1 3/2017 Guo  
 2017/0115125 A1\* 4/2017 Outwater ..... G08G 1/123  
 2017/0147959 A1\* 5/2017 Sweeney ..... G07C 5/008  
 2017/0169535 A1 6/2017 Tolkin  
 2017/0191841 A1 7/2017 Marueli  
 2017/0191845 A1 7/2017 Marueli  
 2017/0193458 A1 7/2017 Marco  
 2017/0200249 A1 7/2017 Ullrich  
 2017/0240098 A1\* 8/2017 Sweeney ..... B60Q 1/5035  
 2017/0255881 A1\* 9/2017 Ritch ..... G08G 1/096822  
 2017/0270794 A1 9/2017 Sweeney  
 2017/0272901 A1 9/2017 Chen  
 2017/0344643 A1 11/2017 Ramesan  
 2017/0357408 A1 12/2017 Anglin  
 2018/0005145 A1 1/2018 Lo  
 2018/0060838 A1 3/2018 Agrawal  
 2018/0091604 A1 3/2018 Yamashita  
 2018/0101925 A1 4/2018 Brinig  
 2018/0121835 A1 5/2018 Salonen  
 2018/0121847 A1 5/2018 Zhao  
 2018/0211351 A1 7/2018 Kim  
 2018/0293521 A1 10/2018 Akselrod  
 2018/0306595 A1 10/2018 Marueli  
 2018/0315148 A1 11/2018 Luo  
 2018/0321049 A1 11/2018 Lim  
 2018/0339714 A1 11/2018 Smid  
 2018/0349825 A1 12/2018 Yamamoto  
 2018/0356239 A1 12/2018 Marco  
 2018/0374350 A1 12/2018 Sweeney  
 2019/0109910 A1 4/2019 Sweeney  
 2019/0149945 A1 5/2019 Chheda  
 2019/0172353 A1 6/2019 Chen  
 2019/0212157 A1 7/2019 Wu  
 2019/0244318 A1 8/2019 Rajcok  
 2019/0265703 A1 8/2019 Hicok  
 2019/0295206 A1 9/2019 Yamashita  
 2020/0005370 A1 1/2020 Jung  
 2020/0041291 A1 2/2020 Dunnette  
 2020/0104761 A1 4/2020 Aich  
 2020/0128361 A1 4/2020 Chheda  
 2020/0145503 A1 5/2020 Sweeney  
 2020/0211070 A1 7/2020 Singh  
 2020/0027368 A1 8/2020 Bhattacharyya  
 2020/0258344 A1 8/2020 Brinig  
 2020/0273337 A1 8/2020 Sweeney  
 2021/0010817 A1 1/2021 Wu  
 2021/0048300 A1 2/2021 Saavreda  
 2021/0223051 A1 7/2021 Hochberg  
 2021/0256437 A1 8/2021 Stayner  
 2021/0266703 A1 8/2021 Chheda  
 2021/0312338 A1 10/2021 Stayner

2022/0006870 A1 1/2022 Sweeney  
 2022/0223043 A1 7/2022 Sweeney  
 2023/0306326 A1 9/2023 Stayner

FOREIGN PATENT DOCUMENTS

CN 106651728 5/2017  
 DE 10201607712 11/2016  
 EP 2682868 1/2014  
 EP 2879410 6/2015  
 EP 3046058 7/2016  
 JP 2004-302942 10/2004  
 WO WO 2010142862 12/2010  
 WO WO 2011-120161 10/2011  
 WO WO 2017/079222 5/2017

OTHER PUBLICATIONS

Written Opinion in PCT/US2018/055256 dated Jul. 19, 2019.  
 Office Action in EP 17771000.1 dated Aug. 23, 2021.  
 Office Action in CA 3017822 dated Jun. 1, 2022.  
 Office Action in CA 3017638 dated Jun. 22, 2022.  
 Jain, "Context based adaptation of application icons in mobile computing devices", 2013 Third World Congress on Information and Communication Technologies (WICT 2013) pp. 31-36, 2013\*.  
 ISR and Written Opinion in PCT/US2018/055256 dated Jan. 30, 2019.  
 ISR and Written Opinion in PCT/US2017/023350 dated Jun. 29, 2017.  
 ISR and Written Opinion in PCT/US2017/023343 dated Jul. 6, 2017.  
 ISR and Written Opinion dated Apr. 30, 2019 in PCT/US2019/012902.  
 Is it possible to order 2 Ubers at the same time, Jul. 13, 2015 ([https://web.archive.org/web/20150801000000\\*/https://android.stackexchange.com/questions/114027/is-it-possible-to-order-2-ubers-at-the-same-time](https://web.archive.org/web/20150801000000*/https://android.stackexchange.com/questions/114027/is-it-possible-to-order-2-ubers-at-the-same-time)).  
 IPRP in PCT/US2016/037088 dated Dec. 21, 2017.  
 International Search Report and Written Opinion in PCT/US2016/037088 dated Aug. 24, 2016.  
 How to request multiple Uber vehicles, Aug. 15, 2013 (<https://www.wikihow.com/Request-Multiple-Uber-Vehicles>).  
 How to book two cabs at the same time in Uber, Jun. 30 2017 (<https://fastandclean.org/book-two-cabs-time-uber>).  
 Fast and Clean, How to booktwo cabs at the same time in Uber, Jun. 30, 2017 (<https://fastandclean.org/book-two-cabs-time-uber>).  
 Exam Report No. 2 in AU 2017328067 dated Jan. 22, 2022.  
 Exam Report No. 2 in AU 2017328067 dated Jan. 20, 2022.  
 Exam Report No. 1 in AU 2017238096 dated Jul. 19, 2021.  
 Exam Report No. 1 in AU 2017238067 dated Mar. 11, 2021.  
 Exam Report No. 1 in AU 2016293831 dated Aug. 28, 2019.  
 EESR in EP 17771000.1 dated Mar. 21, 2019.  
 EESR in EP 16824968.8 dated Jan. 30, 2019.  
 Darrell Etherington: "Google Maps on Mobile Gets Uber Integration and More", May 6, 2014 URL: <https://techcrunch.com/2014/05/06/google-maps-on-mobile-gets-uber-integration-and-more>.  
 Cody Toombs: Maps v.9.19 Introduces New 'Driving Mode'with Traffic Update and ETAs, Audio Toggle for Navigation, and Timeline Settings [APK Download and Teardown], Jan. 12, 2016 URL: <http://www.androidpolice.com/2016/01/12/maps-v9-19-introduces-new-driving-mode-with-traffic-updates-and-et-as-audio-toggle-for-navigation-and-timeline-seeings-apk-download-teardown/>.

\* cited by examiner

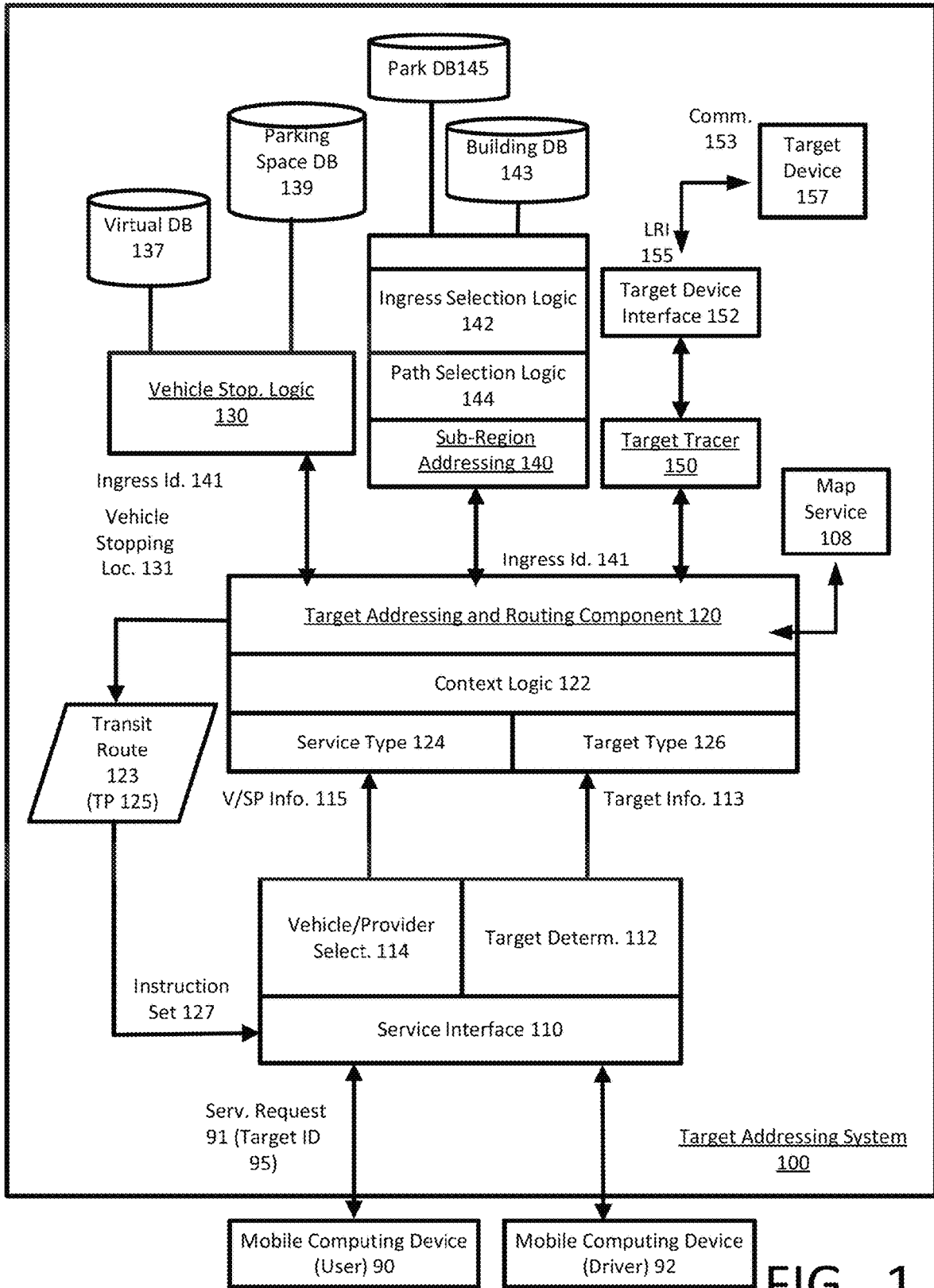

FIG. 1

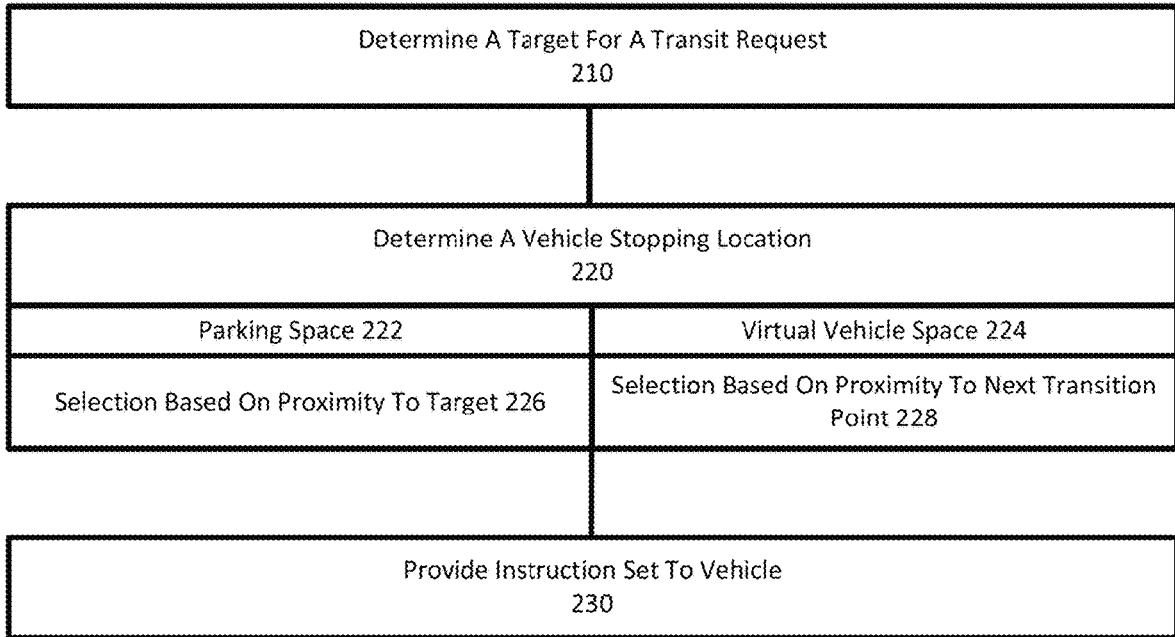

FIG. 2A

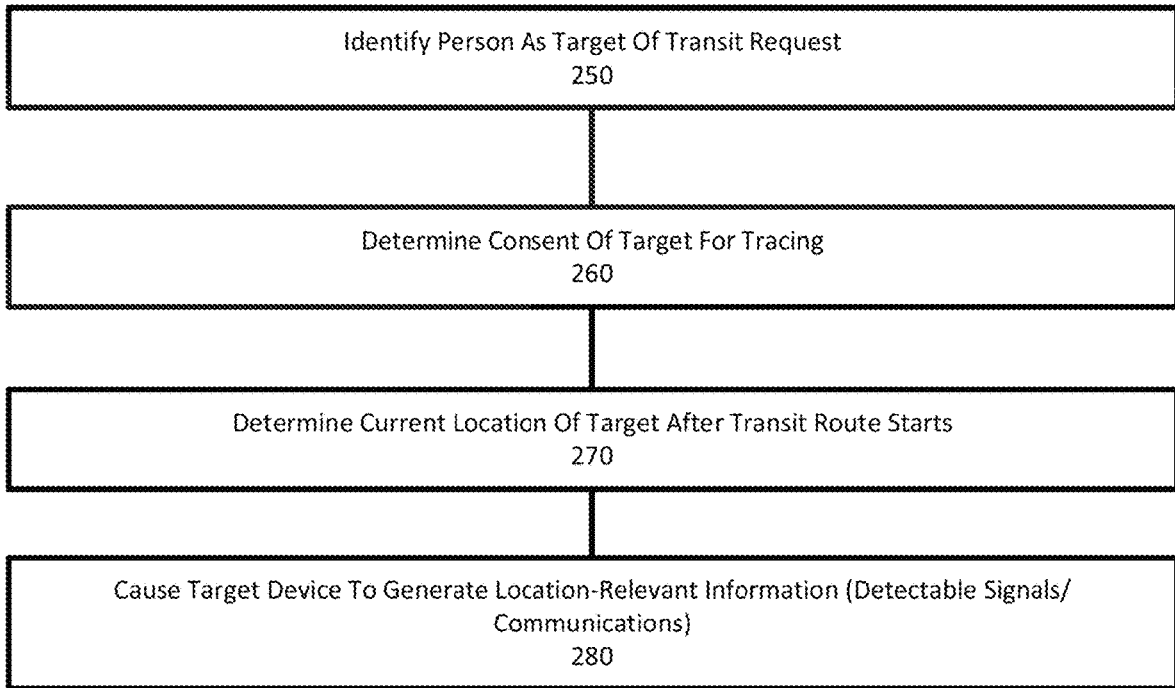

FIG. 2B

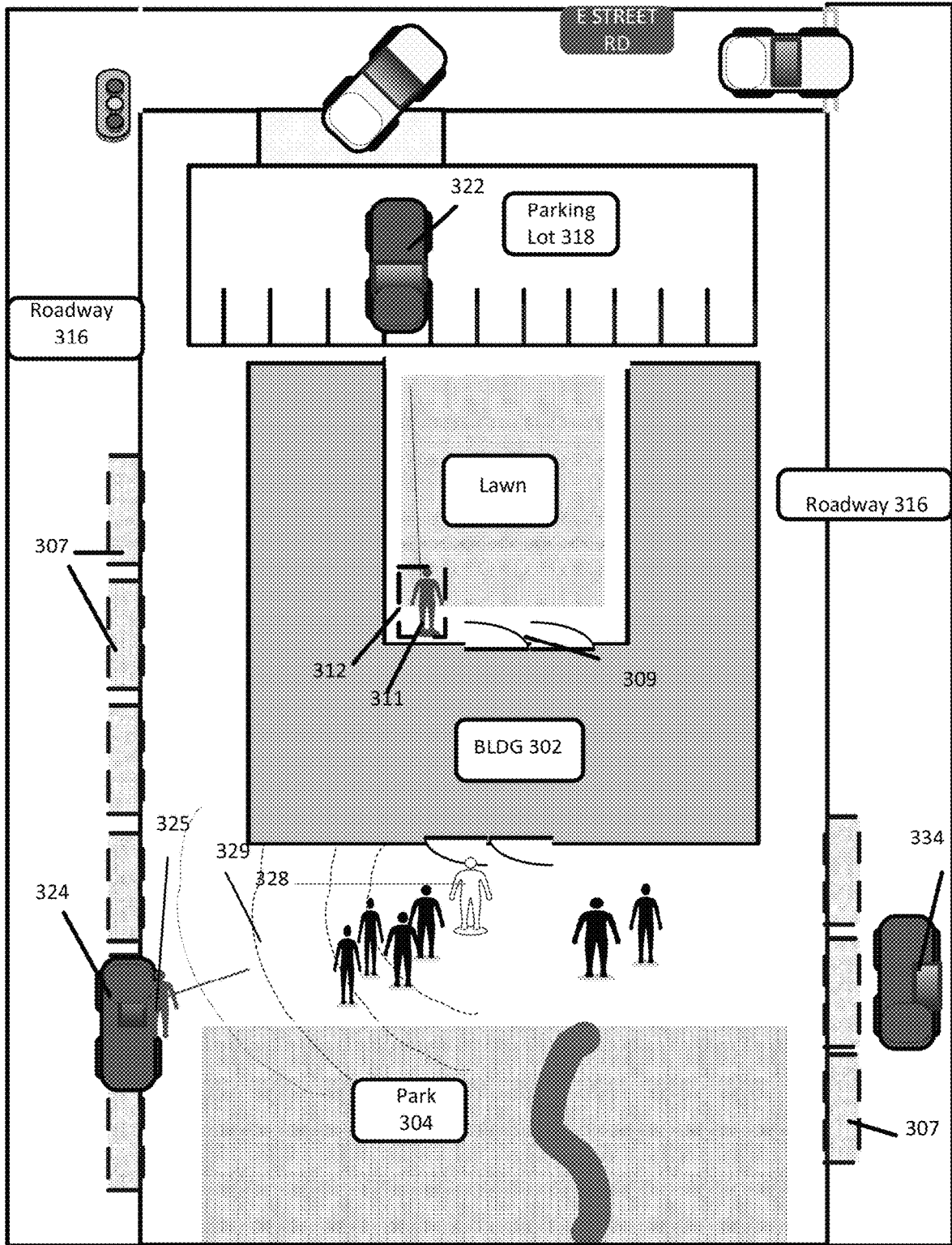

FIG. 3

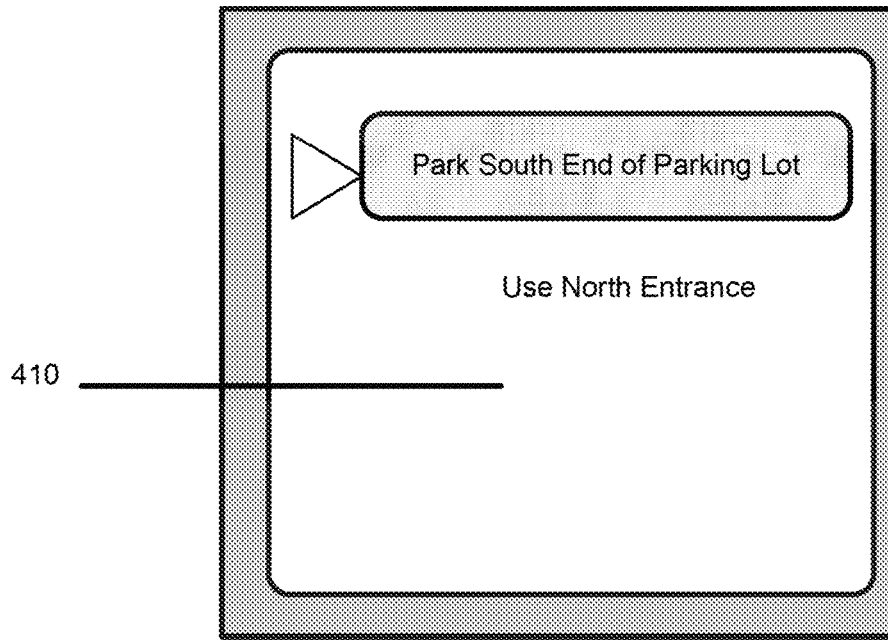

FIG. 4A

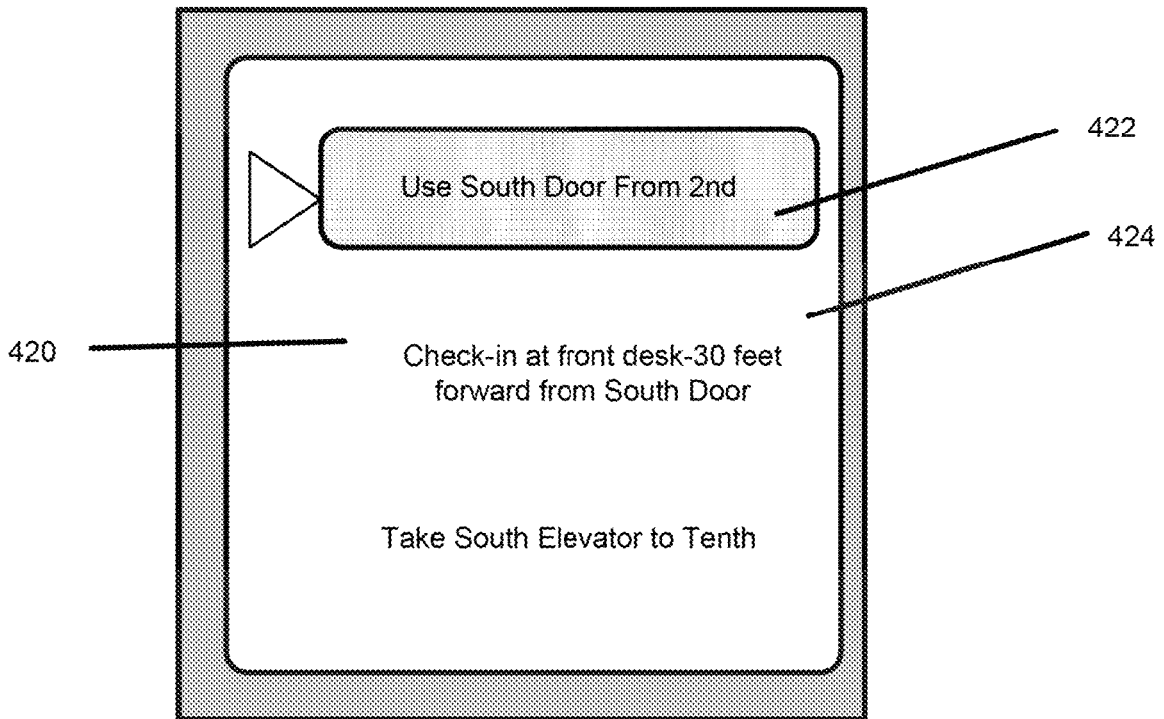

FIG. 4B

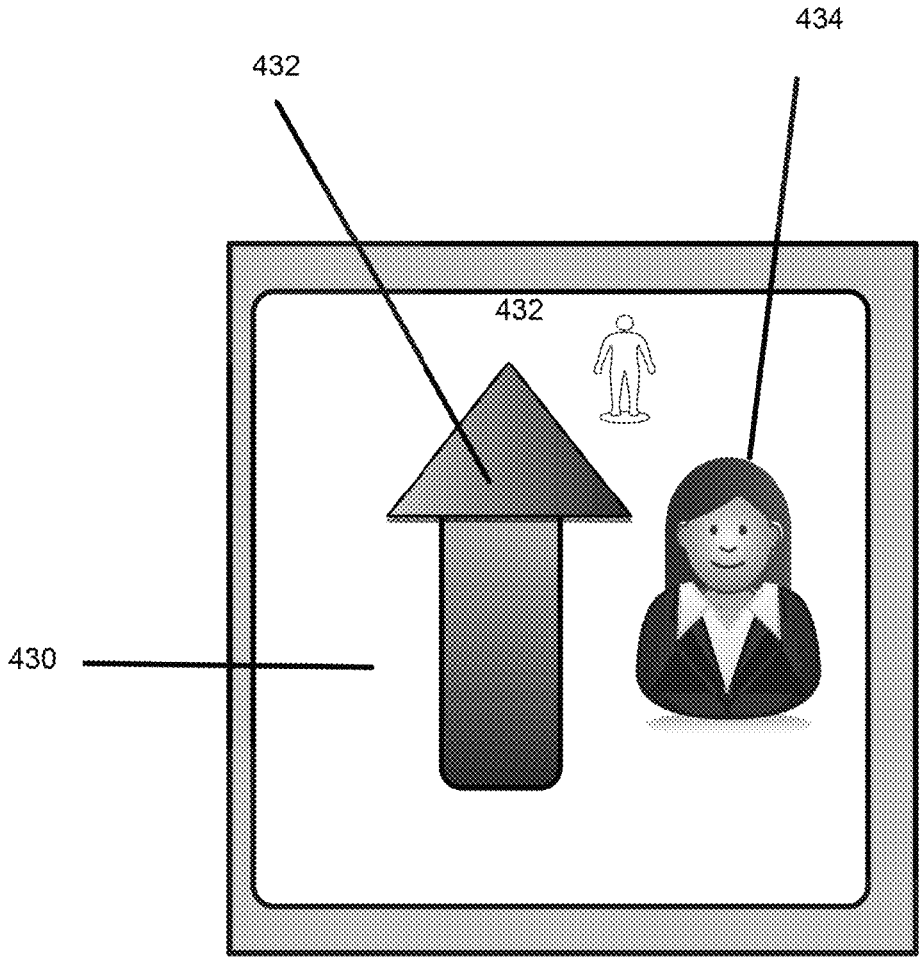

FIG. 4C



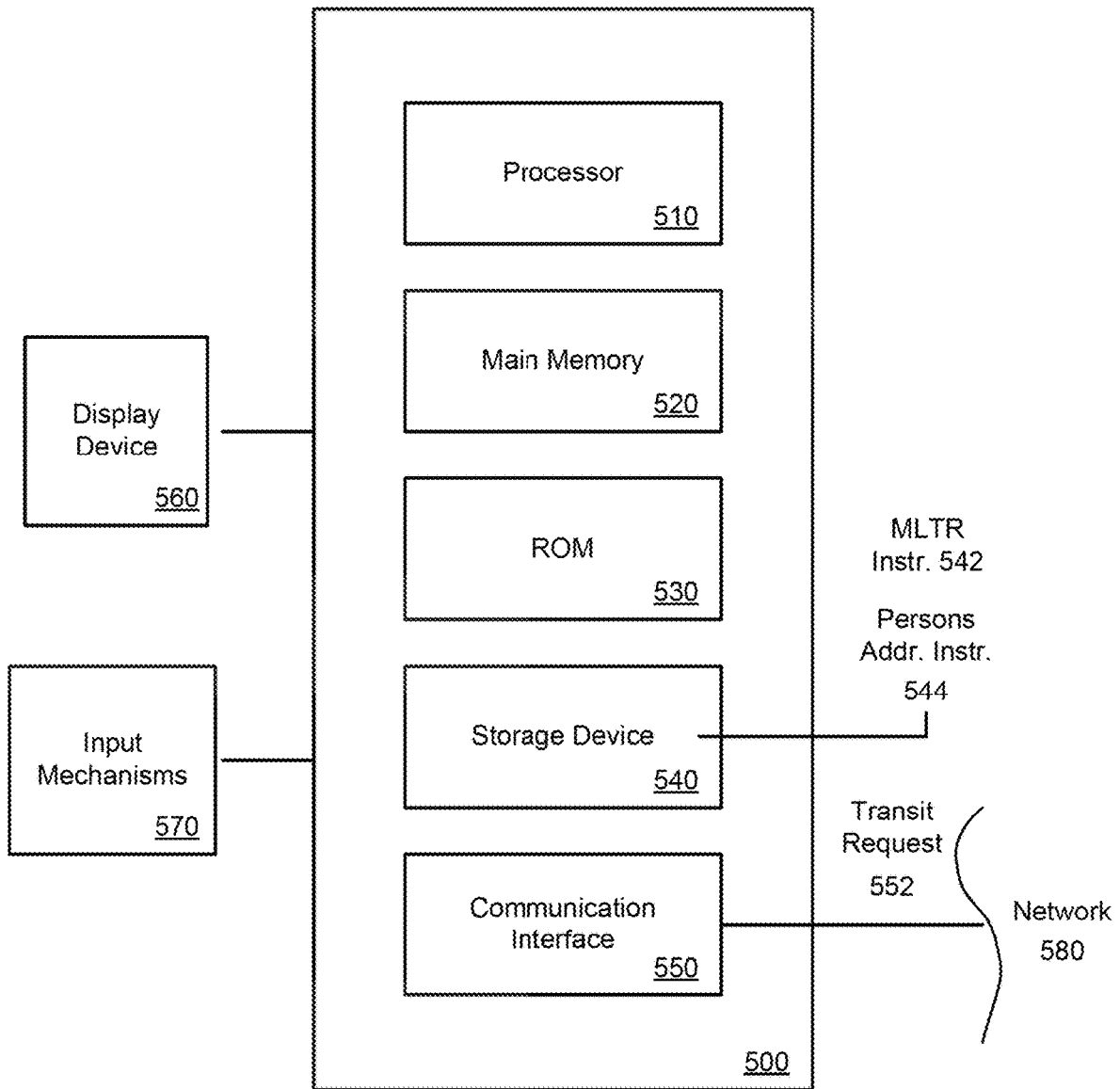

FIG. 5

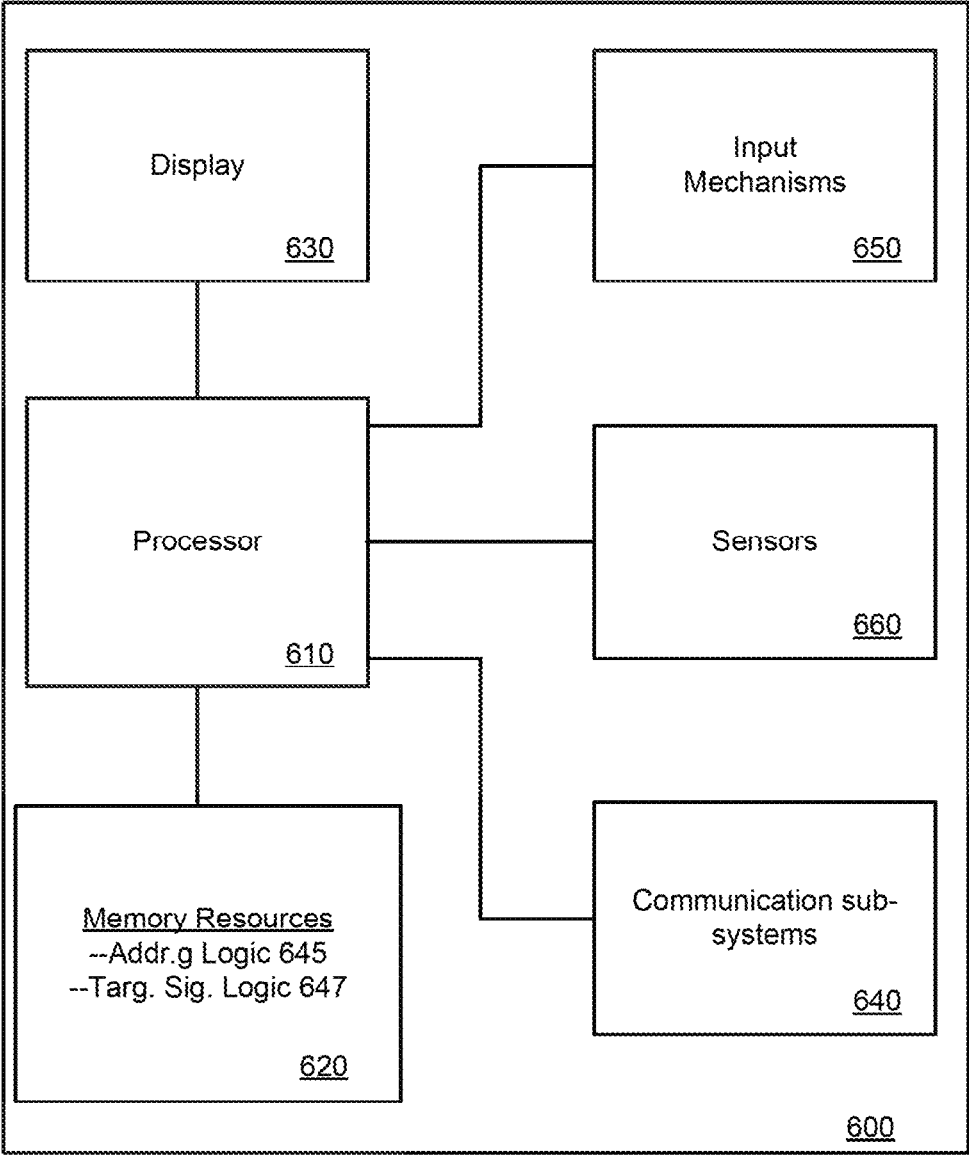

FIG. 6

**TARGET ADDRESSING SYSTEM**

## RELATED APPLICATIONS

This application is a continuation of U.S. patent applica- 5  
 tion Ser. No. 17/592,392, filed on Feb. 3, 2022; which is a  
 continuation of U.S. patent application Ser. No. 15/930,223,  
 filed on May 12, 2020 (now U.S. Pat. No. 11,263,905);  
 which is a continuation of U.S. patent application Ser. No. 16/118,916, filed on Aug. 31, 2018 (now U.S. Pat. No. 10,720,056); which is a continuation of U.S. patent applica- 10  
 tion Ser. No. 15/465,003, filed Mar. 21, 2017 (now U.S.  
 Pat. No. 10,115,308); which claims the benefit of priority to  
 U.S. Provisional Patent Application No. 62/311,339, filed 15  
 Mar. 21, 2016; the aforementioned applications being  
 hereby incorporated by reference in their respective entire-  
 ties.

## BACKGROUND

For any arbitrary location on the map (e.g., given a  
 latitude and longitude coordinate), a typical reverse geo-  
 coding operation returns an address for the location. This is  
 the typical reverse geocoding address.

## BRIEF DESCRIPTION OF THE DRAWINGS

FIG. 1 illustrates a dynamic addressing system for use  
 with transit services, according to one or more embodi-  
 ments.

FIG. 2A illustrates an example method for addressing a  
 vehicle or user to a target, according to one or more  
 embodiments.

FIG. 2B illustrates a method for addressing a vehicle or  
 user to a target that is a person.

FIG. 3 illustrates various examples for routing service  
 providers to targets within a geographic region.

FIG. 4A through FIG. 4C illustrate interfaces for a com-  
 puting device of a service provider, according to one or more  
 examples.

FIG. 5 is a block diagram that illustrates a computer  
 system upon which embodiments described herein may be  
 implemented.

FIG. 6 is a block diagram that illustrates a mobile com-  
 puting device upon which embodiments described herein 45  
 may be implemented.

## DETAILED DESCRIPTION

Examples include a system and service for addressing 50  
 users, vehicles, and service providers to targets using multi-  
 segmented routes and/or targets whom are persons.

According to some examples, an addressing system deter-  
 mines a target for a service request. The addressing system  
 determines a vehicle stopping location for a transit route to 55  
 the target, where the vehicle stopping location is different  
 than a location of the target. The addressing system may  
 send an instruction set to a vehicle that is providing the  
 transit service, where the instruction set identifies the  
 vehicle stopping location as part of a sequence in which the 60  
 vehicle comes to a stop to fulfill the service request.

As used herein, a client device, a driver device, a com-  
 puting device, and/or a mobile device refer to devices  
 corresponding to desktop computers, cellular devices or  
 smartphones, wearable electronic devices, laptop comput- 65  
 ers, tablet devices, etc., that can provide network connec-  
 tivity and processing resources for communicating with the

system over one or more networks. Client devices and driver  
 devices can each operate a designated service application  
 (e.g., a client application and a driver application, respec-  
 tively) that is configured to communicate with an on-  
 demand service arrangement system. A driver device can  
 also correspond to a computing device that is installed in or  
 incorporated with a vehicle, such as part of the vehicle's  
 on-board computing system.

One or more examples described herein provide that  
 methods, techniques, and actions performed by a computing  
 device are performed programmatically, or as a computer-  
 implemented method. Programmatically, as used herein,  
 means through the use of code or computer-executable  
 instructions. These instructions can be stored in one or more  
 memory resources of the computing device. A programmati- 15  
 cally performed step may or may not be automatic.

One or more examples described herein can be imple-  
 mented using programmatic modules, engines, or compo-  
 nents. A programmatic module, engine, or component can  
 include a program, a sub-routine, a portion of a program, or  
 a software component or a hardware component capable of  
 performing one or more stated tasks or functions. As used  
 herein, a module or component can exist on a hardware  
 component independently of other modules or components. 25  
 Alternatively, a module or component can be a shared  
 element or process of other modules, programs or machines.

Some examples described herein can generally require the  
 use of computing devices, including processing and memory  
 resources. For example, one or more examples described  
 herein may be implemented, in whole or in part, on com-  
 puting devices such as servers, desktop computers, cellular  
 or smartphones, personal digital assistants (e.g., PDAs),  
 laptop computers, printers, digital picture frames, network  
 equipment (e.g., routers) and tablet devices. Memory, pro-  
 cessing, and network resources may all be used in connec-  
 tion with the establishment, use, or performance of any  
 example described herein (including with the performance  
 of any method or with the implementation of any system). 30

Furthermore, one or more examples described herein may  
 be implemented through the use of instructions that are  
 executable by one or more processors. These instructions  
 may be carried on a computer-readable medium. Machines  
 shown or described with figures below provide examples of  
 processing resources and computer-readable mediums on  
 which instructions for implementing examples described  
 herein can be carried and/or executed. In particular, the  
 numerous machines shown with examples described herein  
 include processor(s) and various forms of memory for  
 holding data and instructions. Examples of computer-read-  
 able mediums include permanent memory storage devices,  
 such as hard drives on personal computers or servers. Other  
 examples of computer storage mediums include portable  
 storage units, such as CD or DVD units, flash memory (such  
 as carried on smartphones, multifunctional devices or table-  
 ts), and magnetic memory. Computers, terminals, network  
 enabled devices (e.g., mobile devices, such as cell phones)  
 are all examples of machines and devices that utilize pro-  
 cessors, memory, and instructions stored on computer-read-  
 able mediums. Additionally, examples may be implemented  
 in the form of computer-programs, or a computer usable  
 carrier medium capable of carrying such a program. 40

## SYSTEM DESCRIPTION

An "address," and variants such as "addressing" is  
 intended to mean a descriptor or identifier for a location. In

the context of a route, an address can refer to a portion or segment of a route just prior to a transition or completion point.

A “target” refers to an objective for completing a route. According to examples, the target can include a person, a space in a public area, a particular location in sub-regions such as a building, a location within a mall, a park or other enclosure. Examples contemplate targets of varying granularity or dimension, such as a parking space, a virtual space of dimension that can occupy a vehicle, or a visible vicinity in proximity to an individual standing on a sidewalk or within a building. With examples, a target can also be dynamic, meaning the location of the target may move while a person or vehicle is being routed to the target.

FIG. 1 illustrates a target addressing system, according to one or more embodiments. A target addressing system 100 can be implemented as part of a network service by which transit services may be requested, facilitated, and/or arranged. Accordingly, examples such as shown with FIG. 1 may be implemented using, for example, a server or a combination of servers, communicating with mobile computing devices carried by providers and users for a transit service. In variations, some or all the functionality described with the addressing system 100 may be implemented using a distributed computing environment, such as provided by client computers and/or mobile computing devices which communicate with the network service.

In an example of FIG. 1, the addressing system 100 includes a service interface 110, a target address and routing component (TARC) 120, and one or more logical components for addressing a transit object in furtherance of a service request. In one example, one or more addressing subsystems of the addressing system 100 may include vehicle stopping logic 130, a sub-region addressing logic or component 140, and a target tracing component 150.

The service interface 110 may receive a service request 91 from any one of multiple types of sources, including a mobile computing device 90 of a user, or a programmatic entity residing with a server or autonomous entity (e.g., autonomous vehicle, drone, robotic locomotive). In an example of FIG. 1, the service interface 110 communicates with the mobile computing device 90 to receive the service request. In response to receiving the service request 91 and/or in response to the service request 91 being processed by the network service, the target addressing system 100 generates a transit route 123 that includes instructions to address a user, service provider, vehicle or autonomous entity to a location that is in proximity to a desired target. In some examples, the service request 91 is fulfilled at least in part by a human operator. For example, the service request 91 may correspond to a rider requesting a transport from a transport service (e.g., on-demand transport), a user requesting a delivery, or a messenger service (e.g., using vehicle, bicycle or runner).

In variations, the service request 91 can be fulfilled at least in part by an autonomous or robotic entity, such as an autonomous vehicle, a drone, or robotic locomotive. For example, the service request 91 may be fulfilled by a human user or operator meeting an autonomous entity at a target location. In other examples, the service request 91 can be fulfilled by an autonomous entity (e.g., autonomous vehicle) meeting another autonomous entity (e.g., drone) at a target location to exchange a physical object or perform another task. In such examples, the addressing system 100 fulfills the service request 91 by enabling a human or autonomous entity to meet a recipient autonomous entity at a target location that, for example, is less than four (4) feet in its

greatest dimension. The addressing system 100 can operate to enable such a meeting by providing each entity (human or autonomous) an address to the target location (e.g., meeting location), so that each entity arrives at the target location within a threshold time period (e.g., within 5 seconds of each other).

In some examples, the service request 91 may include an identifier 95 of a target. The target identifier 95 can correspond to a global positioning system (“GPS”) location, a map pin drop location (e.g., a location specified by a pin on a map user interface), a business name, landmark, or conventional street address. Still further, in some variations, the target identifier 95 can correspond to a name, phone number, moniker (e.g., alias used by a person) or other identifier of a human being. In other examples, the target identifier 95 can provide an identification of any object or place which can be located in a serviced geographic region at a given point interval of time (e.g., time interval of x seconds, minutes, hours, etc.). The addressing system 100 can generate the transit route 123 to, for example, (i) direct a user, service provider, vehicle or autonomous entity to a pickup location of a transport request, (ii) transport a rider from a pickup location to a drop-off location, (iii) deliver an item to a location or person, (iv) transport a rider to a location that is near a specific person, or (v) instruct an autonomous entity to arrive at a virtually defined location at a particular time interval.

Within the addressing system 100, the service request 91 can be processed to determine target information 113 for the target identifier 95 of the service request 91. A target determination component 112 can determine various types of information about a target of the service request 91, such as a type or classification of the target (e.g., person, an area on a street, a place within a building or business (or mall, park or other sub-region). According to examples, the target determination component 112 can correspond to, or be a part of, a transit matching system of the network service. The target determination component 112 can also be in communication with the service interface 110, such as illustrated in the example of FIG. 1. The target determination component 112 can utilize databases or other services (including third-party services) in order to determine information about the target. In some examples, the target determination component 112 accesses a semantic address database or service in order to determine a semantic address for the target. In such examples, the target information 113 corresponds to a semantic address that identifies a particular location using directional and/or spatial terms that are relative to a visually apparent landmark (e.g., “50 feet from the corner of Main Street and First”). Co-pending U.S. patent application Ser. No. 14/738,698 describes a system which can generate semantic, human understandable addresses in terms of landmarks, direction and proximity terms; and the aforementioned application is hereby incorporated by reference in its entirety. The target determination component 112 can determine target information 113 using input specified with the service request 91. For example, the target determination component 112 can determine the target information 113 using a GPS coordinate, mailing street address, business name, or sub-region identifier (e.g., building, park, strip mall, etc.).

In some implementations, the target determination component 112 can utilize a map service 108 and/or a GPS coding or reverse coding database to translate, for example, GPS coordinates to street addresses.

In one implementation, the target of the service request 91 corresponds to a human being, or alternatively, to a com-

puting device (e.g., mobile computing device, wearable device, etc.) carried by an individual who is the target. As an example, a rider may request a transport service, and then specify a human being as the destination. For example, the rider can operate a client application on the mobile computing device **90** to specify a transit service, a pickup location, and/or a destination or target. The rider can select a feature, such as a “destination” field, and have the option of inputting or searching for a destination location and/or inputting or searching for a phone number or name (e.g., or another identifier) from the rider’s contacts/phone application, messaging application, or social networking application. For example, the client application can communicate, e.g., via an application programming interface (API), with such applications of the mobile computing device **190** to display data from the application(s) in the user interface of the client application. The rider can then select an identifier of the person to travel to. In such an example, the driver or vehicle may then be selected by the network service to provide the transit service by transporting the rider to the location of the specified person.

As another example, a customer may request a delivery service (e.g., package delivery, service process) in which a package is delivered to a specific person, and the target addressing system **100** addresses a provider (e.g., package deliverer) to arrive at the location of the target person, with the provided address being sufficient to instruct the provider to locate the target without need of assistance or return communication from the target. Accordingly, examples provide for the target addressing system **100** to address the transit request to the location of the target even while the location of the target is in flux. In such examples, the target of the service request **91** can correspond to an identifier associated with a person. For example, the service request **91** can include a name, alias, and/or device identifier for a computing device associated with an individual (e.g., mobile phone number, service application moniker, etc.). By way of example, the service request **91** can specify any of the following: (i) “Package for Julia Jones,” or “Package for 415-555-2233,” (for transit service corresponding to package delivery); (ii) “Meeting User jojojones2233” (for transit service corresponding to transport request); or (iii) 415-555-2233.

Additionally, the service interface **110** can process the service request **91** to determine information such as what kind of vehicle or transit mechanism is required to fulfill the request, and how many phases or legs are required to fulfill the transit request. The transit type can be defined by the service provided (e.g., human delivery) or by a vehicle or vehicle type (e.g., delivery truck, autonomous vehicle, etc.). Additionally, the service interface **110** can include vehicle/provider selection logic **114** to select a vehicle or service provider from an available pool using criteria such as proximity and availability. With the selection, the vehicle/provider selection logic **114** can determine vehicle/service provider information **115**, which can include information such as vehicle or service type, as well as driver or user who is providing or using the transit service.

The TARC **120** can utilize the target identifier **95**, the target information **113** (e.g., street side location, location inside building, specific human being, etc.), and/or vehicle/service provider information **115** to determine a transit route **123** for the service request **91**. The transit route **123** can include one or more target addresses that serve to locate one or more transition and/or completion locations for the transit route **123**. In variations, the TARC **120** may determine that the requested transit service requires one mode of transport

tation to reach a desired location near the target (e.g., one leg of transit route **123**). The TARC **120** may alternatively determine that the requested transit service requires multiple legs, including at least one transition point where a user or object of transport transitions between transit mechanisms. For example, a human user or service provider may transition from a vehicle leg to a pedestrian leg where the user or provider fulfills the remainder of the service request on foot. For example, when the target is a person in a building, the TARC **120** may identify a first transit leg that guides the user/vehicle or service provider to drive a vehicle to a first transition point, where the user or provider can exit the vehicle. In this example, another leg of the transit route **123** can guide the user or provider to a selected ingress of the building. Still further, one or more legs of the transit route **123** may guide the user/provider within the building. For example, the system **100** may instruct the user/provider to walk within the building (e.g., using stairs, elevators, hallways, etc.) to reach a business.

The target may correspond to a location within the business, such that the transit route **123** terminates once, for example, the user or service provider reaches the receptionist area of the business. Alternatively, another leg of the transit route **123** may initiate once the user/provider reaches the business, with the leg instructing the user/provider to a vicinity of a person identified as the target. In this way, TARC **120** can assemble multiple legs of a transit service, collectively providing a multi-segmented (or legged) transit route **123** that guides the user or service provider to the particular location of the target.

In variations, the TARC **120** may identify multiple autonomous entities which are to combine and transport a person or object from a start location to the target location. The autonomous entities may be of different types (e.g., vehicle and drone), such that the arrival of one entity at the target location is timed with the arrival of another entity at the same target location. The TARC **120** can instruct each of the respective autonomous entities to arrive at a location where the leg of the human/object transport is to change in entity type. The TARC **120** may then instruct the autonomous entity of the second leg in arriving at the target location.

In order to determine multiple legs for transit route **123**, the TARC **120** can include logic to determine stopping or transition points **125** as part of the transit route, with each stopping or transition point signifying a transition between legs of the transit route **123**. As described with various examples, the transition points **125** can include stopping locations for people, human-operated vehicles, or autonomous entities. The transition points **125** may also signify transitions from one type of space to another, such as from an outdoor area to an ingress of a building or sub-region. As another example, a transition point **125** can identify a point of transition for a passenger or object (e.g., package changing hands), moving from a parking lot to a sidewalk as part of a transit route **123**. In determining the transit route **123**, the TARC **120** can determine the number of transit legs required, as well as the stopping or transition points, with an objective being to direct or guide the user or provider to the target in a manner that optimizes an objective of the transit route **123**. For example, the objective may seek to minimize the distance or time of travel for the transit route **123**, or alternatively, to maximize the proximity of the user/vehicle or service provider to the target at the termination of the route.

According to some variations, the TARC **120** selects portions of the transit route **123** based on contextual infor-

mation. By way of example, the contextual information may include, as determined from target information **113** and service provider information **115**, a type of target, vehicle or service used to fulfill the service request **91**.

In an example of FIG. 1, the TARC **120** may include context logic **122**, which may include rules that factor decisions that affect the selection of portions of the transit route and/or transition points. In particular, context logic **122** can include generalized logic that implements rules that are not specific to location. For example, the transit route **123** may specify that within a building, a person should take stairs to a business that is on the second floor under the assumption that it would take less time to take the stairs. Accordingly, context logic **122** can factor conditions such as time of day, day of week, calendar day, traffic conditions, weather, or other environmental or known variables which may affect an objective of the transit route (e.g., minimizing the transit time, minimizing the distance between the final location of the service provider and the target etc.). In rainy weather, for example, the context logic **122** may cause the TARC **120** to select a vehicle stopping location for the vehicle on the transit route to be one that is indoor or undercover, when the TARC **120** would otherwise select a closer, outdoor stopping point in better weather.

As an addition or variation, the context logic **122** may also include service type logic **124**, corresponding to weights or rules for implementing the context logic **122** based on the type of service in use for the transit route or leg. For example, the TARC **120** may determine a different transition point **123** when the first leg of a transit route **123** is completed by a vehicle, based on whether the vehicle is human driven or an autonomous vehicle. For example, the TARC **120** may operate under the assumption that human driven vehicles can be more responsive to dynamic and unknown events on the side of an urban roadway. To further the example, the TARC **120** may guide the human driven vehicle to a vehicle stopping point that corresponds to a visually undefined space on a side of a roadway, while the autonomous vehicle may be guided to a parking space that is well-defined.

Still further, the context logic **122** can also include target logic **126**, corresponding to weights or rules for determining the transit route or portion thereof, based on the target information. For example, the target logic **126** can include weights or rules that are specific for a particular sub-region (e.g., specific building, park, mall, etc.). For example, the target logic **126** can specify which entrance to a building or park is preferred based on specific conditions (e.g. time of day or day of week, weather, a type of vehicle used for transit to location near building, etc.). The entrance to the building or park can affect, for example, a vehicle portion of the transit route **123** by influencing the selection of the preceding vehicle stopping location **131** by the TARC **120**.

In one example, the TARC **120** utilizes a map service **108** in order to determine at least a portion of the transit route **123**. According to some examples, the TARC **120** utilizes vehicle stopping logic **130** to determine a vehicle stopping location **131**, corresponding to a transition point **125** for a vehicle on the roadway. For transit routes having one segment that terminates on a roadway, the vehicle stopping logic **130** can identify where the vehicle may stop to satisfy conditions or criteria for proximity to the target. In the case where a user makes a service request **91** (e.g., transit request), the vehicle stopping logic **130** can determine (i) a suitable roadway stopping location, and/or (ii) a municipally

defined parking spot. The roadway stopping location may identify locations where a vehicle can, for example, park temporarily, or double park.

In some variations, the vehicle stopping logic **130** implements a database of virtualized vehicle stopping spaces. In one implementation, the target addressing system **100** includes, or has access to a database of virtual vehicular stopping spaces (“VVSS Database **137**,” or “Virtual DB **137**” as referred to in FIG. 1). The VVSS database **137** can logically pre-define vehicle stopping spaces, with each vehicle stopping space corresponding to a space on a roadway where vehicles are permitted to stop, at least for purposes such as rider pick-ups and drop-offs, loading or unloading, or parking for a limited duration of time. The vehicle stopping spaces of the VVSS database **137** can be dimensioned, for example, to accommodate a single vehicle at any one time. The vehicle stopping spaces of the VVSS database **137** can each be associated with parameters that define, for example, a time of day when the vehicle space exists. Other parameters may also define, for example, a type of vehicle which may use the vehicle stopping space (e.g., sedan, or vehicles of certain dimension). Still further, individual vehicle stopping spaces of the VVSS database **137** can be associated with availability parameters, which dictate how likely a vehicle stopping space is going to be available based on contextual information (e.g., day or week, time of day, amount of traffic) and/or sampling of known information (e.g., feedback or input from other vehicles on the roadway).

The TARC **120** can use the vehicle stopping logic **130** to identify one or more vehicle stopping spaces. Once identified, the TARC **120** can communicate the vehicle stopping spaces to providers as part of the transit route **123**. In variations, the vehicle stopping logic **130** can include a vehicle interface **132**, to enable providers or autonomous vehicles to receive information about the stopping spaces independently of a particular transit. As an addition or alternative, the vehicle interface **132** can provide information that identifies the vehicle spaces in the form of a virtual layer that overlays or accompanies map content, such as provided to a computing device in use in a given vehicle for navigation purposes. In other examples, the vehicle interface **132** can include functionality for receiving location input from individual vehicles (e.g., transit vehicles), and using the VVSS database **137** to identify vehicle spaces that are near the vehicles.

The VVSS database **137** can be generated for a given geographic region using a combination of manual and/or automated input. For example, some vehicles can be outfitted with camera sensors that can scan the edge of the roadways along select city blocks to identify side road segments which can receive vehicles without interference to traffic. The stopping/parking rules of the side road segments can also be determined and correlated to the spaces. For example, the vehicles can scan the street signs for parking or stopping rules (e.g., time when parking or stopping is permitted or forbidden), or the information may be retrieved from publicly available data sources. The determined roadway segments can be logically segmented into vehicle spaces (e.g., on map content) and each vehicle space can be associated with an identifier and an address. In some examples, the address for individual vehicle spaces can be defined by dimensional parameters of length and width, with the dimension accommodating a desired threshold (e.g., dimensioned to accommodate a vehicle type). In some variations, the VVSS database **137** can include data that links identified vehicle spaces to (i) rules for when the

vehicle spaces are available (e.g., based on city rules), (ii) rules for how the individual vehicle spaces can be used, such as the duration of time for permissible stopping, or whether the driver can leave the vehicle, and/or (iii) availability data, such as a statistical or analytical determination of whether the space is likely accessible given traffic and demand in a given time period. When determining the stopping location **131** for the vehicle, the vehicle stopping logic **130** can process through a list of virtual spaces, retrieved from VVSS database **137**, to identify an order or hierarchy for a driver or vehicle to view the roadway segment for open vehicle spaces. In one implementation, the virtual spaces can be rendered on a map, or alternatively, described semantically to a driver of the vehicle. For example, the virtual spacing may be identified when the vehicle approaches the target by an addressing statement “available space for 3 vehicles to stop ten feet on right, stop at first available space.” For autonomous vehicles, the virtual spacing can be identified through data transmission that integrates potentially available vehicle spaces with navigation maps in use with the vehicle.

In similar fashion, the vehicle stopping logic **130** can access a database of parking spaces (“parking space database **139**”) for a given geographic region. The parking space database **139** can store information about parking spaces, which can be visually identified and subject to parking rules maintained by a municipality or third-party. In some examples, the parking space database **139** can store information that identifies parking lots and structures, parking spaces within the lots/structures, rules for parking lots or spaces, parking rates for lots or spaces, contextual information that may hinder or promote use of specific spaces or lots (e.g., space is narrow and time consuming to use). The parking space database **139** can also identify those parking spaces which are street parking, which for many transit services are more preferable than parking spaces in parking lots. In some variations, the parking space database **139** can also identify a likelihood or probability that a parking space is available, or that a parking lot or area with have open spaces.

For transit routes having multiple segments, the TARC **120** may utilize a sub-region addressing component **140** to determine a transit completion location or transition point **125** within a sub-region, such as a building, park or mall. In one implementation, the TARC **120** uses the target information **113** to determine whether the desired transit completion location is within a sub-region or on a roadway. If within a sub-region, the sub-region addressing component **140** uses the completion location to identify a path within the sub-region to the completion location.

According to some examples, the sub-region addressing component **140** can include ingress selection logic **142** and path selection logic **144**. The ingress selection logic **142** can select which of multiple possible ingresses to a given sub-region are best, given the location of the target within the sub-region, a portion of the transit route preceding the sub-region, and/or the transition point (e.g., vehicle stopping location **131**) of the preceding transit route. The path selection logic **144** can select a path to the target within the sub-region. In some implementations, the path selection logic **144** can utilize the selected ingress, as determined from the ingress selection logic **142**. In other implementations, the selected ingress can be based on a path to the target, as determined from the path selection logic **144**.

In selecting the ingress and/or the path, the sub-region addressing component **140** can also utilize sub-region databases (e.g., building database **143**, parks database **145**) in

order to determine the portion of the transit route within the sub-region. For example, the building database **143** can include information that identifies individual buildings, including building geometry, layout, points of ingress and egress to the building, elevators (including floors service by individual elevators), stairwells, stairwell rules (e.g., which stairwells are open from ground-floor), building rules (e.g., rule in which transit user may have to sign in with security guard), business specific rules within individual buildings (e.g., which elevators are accessible without pass-cards). For other types of sub-region such as parks, the sub-region addressing component **140** can access the park database **145**, which can include paths, topology, fields, park rules etc. Similar databases may be used for malls (e.g., identify locations of businesses within malls) or other sub-regions. The various sub-region databases **143**, **145** can associate landmarks and businesses with various types of information for locating the businesses or landmarks within the sub-regions. Such information can include GPS coordinates, mailing addresses, a section within the sub-region (e.g., floor in building) and/or directional/spatial descriptors that relate a business or landmark to another landmark or point of reference within the sub-region. The sub-region databases **143**, **145** can also identify adjacent roadways or other path of travel which may be used by a vehicle or provider to reach the sub-region.

The sub-region addressing component **140** can specify a sequence of actions for addressing a user/provider to a target within a sub-region. For example, for a given business in a specific building, the sub-region addressing component **140** can address a person using a sequence of actions that are to be performed, such as (i) distance and direction to first stop for first action within building (e.g., “forward 50 feet from entrance towards desk, check in . . .”), (ii) distance and/or direction to next stop for next action (e.g., “walk right to 2nd elevator from the far wall, push elevator button and then select floor **4** within elevator”), (iii) distance and/or direction to next stop for next action (e.g., “exit left, third door on right”). The sub-region databases **143**, **145** may address to specific locations within a sub-region in this manner, and further utilize landmarks (e.g., for malls, “take escalator to second floor, 5 feet from water fountain, etc.”).

The sub-region addressing component **140** can utilize ingress selection logic **142** to select an ingress **141** of a sub-region, from multiple available ingresses, as part of a transit route within the sub-region. The sub-region addressing component **140** can also select an ingress **141** using information provided in a corresponding sub-region database. Such information may also include one or more of a layout for the sub-region, and a determination as to how frequent individual ingresses in the sub-region are used. The ingress selection logic **142** can further determine the selected ingress **141** using, for example, a determined path within the sub-region to the target, the transition point (e.g., vehicle stopping location **131**) preceding the arrival of the user/provider to the sub-region, and/or the portion of the route of the vehicle to the vehicle stopping location **131**. In making the selection of a particular ingress to the sub-region, the ingress selection logic **142** can optimize the transit route based on one or more parameters, such as (i) minimizing walking distance or time from a vehicle stopping point to the selected ingress of the building, and (ii) maximizing a likelihood that a suitable vehicle stopping point will be available when the vehicle reaches the vicinity of the building.

According to some examples, the TARC **120** can utilize the vehicle stopping logic **130** to select a vehicle stopping

location **131** based on parameters of proximity and/or availability to the selected ingress of the sub-region. Thus, the TARC **120** can first select the ingress to the sub-region based on the location of the target, then use the vehicle stopping logic **130** to determine a suitable vehicle stopping location **131**. In variations, the vehicle stopping logic **130** can be determined from proximity, time of travel or other metric relative to a main ingress or popular ingress of the sub-region. The vehicle stopping logic **130** can further include logic for selecting the vehicle stopping location **131** based on parameters such as (i) a likelihood that the vehicle stopping point is available, and (ii) a proximity of the vehicle stopping location **131** to either the target or the ingress to the sub-region.

According to various examples, the target for a transit service request can correspond to a person, whose location may vary (e.g., dynamically change). For example, a person may move within a geographic region (e.g., within a city or city block), within a building, or within a business or portion of a building. According to examples, a person can be the target of a transit service even when the person moves from the time the transit service starts, and moreover, without the target/person moving to an agreed meeting point. When the service interface **110** receives a transit request in which a target is a person, the target identifier **95** of the person can be determined by the system **100**. For example, the target can correspond to a person who has provided a service identifier (e.g., mobile phone number), along with a permission setting that permits that individual to be located for transit requests (e.g., the individual can be provided with a prompt by the network service giving that individual an opportunity to opt out), with an account store maintained or associated with the system **100**.

According to examples in which the target for a transit request is a human, the TARC **120** can determine the transit route **123** with the last leg of the transit route being a dynamically determined address to locate the target/person. For example, the target may be located within a building, and the transit route **123** can specify (i) a first segment in which the vehicle of the service provider parks at a given location, (ii) one or more additional segments in which the service provider is instructed to move through the building or sub-region to get near the target (e.g., within crowded room), and (iii) a final segment in which the service provider is guided to the target. In the final segment, the user/service provider is addressed to the target using communication exchanges between the target's computing device, the service and/or the service provider's computing device.

The TARC **120** can utilize the tracing component **150** to guide the service provider to the target (e.g., location of target device **157**). The tracing component **150** can implement a tracing protocol or sequence in order to address the service provider to the location of the target. The tracing component **150** can, for example, initiate a communication sequence in which a target device interface **152** is triggered to ping or request a communication **153** from the target's computing device **157** which can be used to identify the location of the target's computing device (e.g., GPS data from the target's computing device). The tracing component **150** can be selective as to when the communication protocol or sequence is initiated. For example, the timing in which target device interface **152** is triggered can be based on proximity of the service provider to the target device **157**.

In one implementation, the tracing component **150** uses target device interface **152** for a coarse determination (e.g., within room or suite of building) of the location of the target. In response to receiving the communication **153** from target

device interface **152**, the target device **155** (e.g., mobile device of another user) can send back location-relevant information **155** about the location of target, such as GPS data, altimeter data, or location relevant data from other resources of the computing device (e.g., third party applications (e.g., calendar application)) running on the computing device of the target. The type, frequency and source of location relevant information **155** may be limited by permission settings of the target.

In some variations, when the user or service provider is sufficiently close to the target device **157**, the mobile computing device of the user/service provider **90**, **92** can switch modes, and seek to communicate directly with or detect signals from the target's mobile computing device.

In one implementation, the mobile computing device of the user or service provider can detect short-range wireless signals and/or communications (e.g., such as communicated over Bluetooth or Wi-Fi) from the target's computing device in order to determine directionality and proximity to the target device's location. The target device interface **152** can, for example, trigger the target device **157** to generate location-relevant information **155** in the form of a distinctive trace signal from which a sensor or antenna of the service provider's device can detect proximity and direction. Based on proximity and directionality indication, the mobile computing device of the service provider **92** can provide feedback such as directional arrows or "hot/cold" feedback, until the provider/user is adjacent to the target.

As an addition or variation, visual indicia can be used (e.g., flash phone of target). Still further, a picture of the target may be revealed to the service provider, such as when the user is near the target.

Methodology

FIG. 2A illustrates an example method for addressing a vehicle or user to a target, according to one or more embodiments. FIG. 2B illustrates a method for addressing a vehicle or user to a target that is a person. In describing examples of FIG. 2A and FIG. 2B, reference may be made to elements of FIG. 1 for purpose of illustrating suitable components for performing a step or sub-step being described.

According to some examples, a target is determined for a transit request (**210**). In some examples, the target can correspond to a static location, such as a location of a pickup request, or a location within a building. In variations, the target can be a human, such that the location of the target may change.

According to some examples, a vehicle stopping location **131** is determined for a transit route that terminates at a location that is near the target (**220**). The vehicle stopping location may correspond to a transition point, from which the transit route can be completed or progressed to another segment. The vehicle stopping location **131** may correspond to a parking space (**222**), or to a roadway segment where vehicle stopping is permitted. In some variations, the target addressing system **100** may maintain a database of virtual vehicular spaces, with each defined vehicle space being associated with an identifier, and the vehicle stopping location **131** may correspond to a virtual vehicle stopping space (**224**). Still further, in some variations, the target addressing system **100** may track when known vehicles utilize the virtual spaces. The vehicle stopping location **131** can be selected from the virtual vehicle spaces (e.g., from VVSS database **137**) and/or parking spaces (e.g., from parking space database **139**).

In some examples, the vehicle stopping point can be determined from a selection criterion that includes proximity



from the vehicle stopping location **131** to the target (**226**). The selection criteria can be specific to a virtual stopping space or parking space, or to a region (e.g., south side of parking lot, road segment north of main entrance, etc.).

In implementations in which the target is a location (e.g., pickup location, drop-off location, etc.), the vehicle stopping location **131** can be selected as a parking space or roadway segment that is near (or nearest) to the pickup location. In variations, the vehicle stopping location **131** can be selected as a parking space or roadway segment that is near (or nearest) to a next transition point for the transit route (e.g., selected ingress into building) (**228**). The basis of selection can include (i) optimizing time or distance for a user or operator to arrive at the target location, either directly or through another route segment (e.g., through a building); and/or (ii) a determination of availability of the spaces. The availability may, for example, be determined from contextual information, such as time of day, day of week or weather (e.g., during rain, cars stop at the side of the road more frequently).

After the vehicle stopping location **131** is determined, an instruction set **127** may be provided to the user or provider, in order to guide the user/provider to the location of the target (**230**). In some implementations, the instruction set **127** can include a sequence of actions the user/operator should perform in order to meet the optimization objective (e.g., minimize time of transit route or distance walked). In some variations, the instruction set **127** may include directional and spatial terms with reference to landmarks which become visible to the user/service provider as he or she progresses through the transit route **123**.

With reference to an example of FIG. 2B, the target addressing system **100** identifies a person who is presumed to have a dynamic (or changing) location while serving as the target of a service request (**250**). The system **100** can perform a look-up of the identifier provided for the person, in order to determine a device identifier for the person. For example, the service request **91** may specify a target person by legal name, and the service interface **110** or other logic of system **100** may identify the mobile computing device phone number, or service application identifier for the person.

The addressing system **100** may determine that the target has consented to be traced for purpose of a given transit route (or transit routes in general) (**260**). In some examples, a setting or stored instruction can be determined from an account of the target, signaling the target's consent to be traced for a transit route. According to some examples, the target addressing system **100** may send a request to the target to obtain the target's consent to be traced for purpose of completing the transit route. In variations, the target may provide consent in the form of a setting or preference.

After the transit route is initiated, the system **100** may make one or more requests from the target's computing device for information that identifies a current location of the target (**270**). The current location of the target may be coarse information, such as provided by GPS coordinates when cross-referenced to a geocoding service. In some examples, a vehicle or person (e.g., user or vehicle) is directed to an estimated location of the target. As the user or vehicle approaches the target or the estimated location of the target, the location of the target may be determined more frequently on the device of the provider. With more frequency determinations, the granularity for the location of the target may become more, until, for example, the target occupies a small area (e.g., 4 foot) within sight of the approaching service provider or user. In variation, a device

of the approaching entity (e.g., provider) may selectively communicate with a device of the target as the two devices get closer. As the two devices become closer, the granularity with respect to the relative location of the two devices can increase.

Still further, in some examples, the target addressing system **100** uses the target device **157** to generate location-relevant information **155**, such as communications or detectable wireless signals for detection and use by the computing device **92** of the provider (**280**). The communications may generate detectable visual or audio output from, for example, the mobile computing device of the target, in order to facilitate, for example, the service provider identifying and locating the target.

FIG. 3 illustrates various examples for routing service providers to targets within a geographic region. In FIG. 3, sub-regions include a building **302** and a park **304**, surrounded by roadways **316**. In one example depicted by FIG. 3, a rider **311** requests a pickup at a pickup location **312**, so that the pickup location may correspond to the target. The addressing system **100** may guide a transport service vehicle **322** that is to pickup the rider **311** to a parking lot **318**. In one implementation, the addressing system **100** sends instructions to the driver of the transport service vehicle **322**, in order to guide the vehicle to a parking space that is near the pickup location **312**. For example, the address system **100** may address the vehicle **322** to park in the parking lot **318** on the south end, so that the vehicle **322** is near the pickup location **312**. Once the vehicle **322** arrives and/or parks, the rider **311** can be signaled by the system **100** to move to and enter the vehicle **322**.

In an example of FIG. 3, the target addressing system **100** can recognize vehicle stopping spaces **307** on the road segments **308** as individual parking spaces, logically defined by an internal map of the vehicle, so as to not be visible on the road segment. In another example, the vehicle **324** may stop in the stopping space **307** in order to be sufficiently near to a location of a target.

Still further, in the example shown, a driver **325** of the vehicle **324** can utilize the virtual stopping space **307** to initiate a new leg of the transit route. The driver **325**, for example, may initiate a pedestrian leg in which the addressing system **100** guides the driver to a target person **328**. The target device interface **152** may signal a computing device of the target to generate wireless signals **329** that are detectable to the computing device of the driver. The computing device of the driver **325** may be programmed or adapted to detect the wireless signals **329**, and further to determine directionality and range from the wireless signals. The driver **325** may start to walk to the target person **328**, until the driver is, for example, immediately adjacent to the target person **328**.

As another example, a vehicle **334** may correspond to an autonomous vehicle that is transporting a passenger to a drop-off location. The system **100** may configure selection of vehicle stopping location based on the vehicle type (e.g., autonomous) or transit service type (e.g., transport). In the example provided, the target can correspond to the location specified by the rider (e.g., the building **306**) and the addressing system **100** elects to ignore virtual stopping spaces based on the vehicle type and/or transit type. For example, the addressing system **100** may weight the selection of the vehicle stopping location to be a parking spot within a parking lot **318**, in order to preclude an unpredictable condition which may be present with use of one of the vehicle stopping spaces **307**. As an addition or alternative, as the transport is to drop-off the rider, the addressing system **100** may weight selection of the parking lot **318**, which is

closest to the entrance **309** of the building **306**. Thus, in the example provided, the vehicle **334** may be instructed to circle the block in order to reach the parking lot **318**.

FIG. 4A through FIG. 4C illustrate interfaces for a computing device of a service provider, according to one or more examples. FIG. 4A illustrates an example interface **410** of a computing device used by a driver of a transit service. The interface **410** may display addressing content to identify the vehicle stopping location for the driver, either to reach the target or a transition point for another leg of the transit route.

FIG. 4B illustrates an example interface **420** to render content for a user or service provider that corresponds to an instruction set for guiding the service provider within a target sub-region. The instruction set rendered with the interface **420** may specify a sequence of instructions which the user or service provider may perform in order to reach a target within a sub-region (e.g., building). In the example provided, the instruction set includes a current action **422** and a next action **424**.

FIG. 4C illustrates an example interface **430** for addressing a user or service provider to a person. In an example shown, the interface **430** can include a directional guide **432** which can represent information determined from an internal sensor or receiver which determines direction and magnitude from a wireless signal generated from the target computing device. For example, the orientation and length of a graphic icon (e.g., icon) can reflect direction and distance to the target. Additionally, an image of the target **434** can be shown, facilitating the user or service provider in spotting the target person from a crowd.

#### Hardware Diagrams

FIG. 5 is a block diagram that illustrates a computer system upon which embodiments described herein may be implemented. For example, in the context of FIG. 1, the target addressing system **100** may be implemented using a computer system such as described by FIG. 5. The target addressing system **100** may also be implemented using a combination of multiple computer systems as described by FIG. 5.

In one implementation, a computer system **500** includes processing resources **510**, a main memory **520**, a read only memory (ROM) **530**, a storage device **540**, and a communication interface **550**. The computer system **500** includes at least one processor **510** for processing information and the main memory **520**, such as a random access memory (RAM) or other dynamic storage device, for storing information and instructions to be executed by the processor **510**. The main memory **520** also may be used for storing temporary variables or other intermediate information during execution of instructions to be executed by the processor **510**. The computer system **500** may also include the ROM **530** or other static storage device for storing static information and instructions for the processor **510**. A storage device **540**, such as a magnetic disk or optical disk, is provided for storing information and instructions, including instructions **542** for determining multi-legged transit routes and instructions **544** for determining transit routes to individual persons or other dynamic targets.

For example, the processor **510** can execute the instructions **542** to implement a method such as described with an example of FIG. 2A. Likewise, the processor **510** can implement logic to implement a method such as described with an example of FIG. 2B.

The communication interface **550** can enable the computer system **500** to communicate with one or more networks **580** (e.g., cellular network) through use of the network link (wireless or wireline). Using the network link, the

computer system **500** can communicate with one or more other computing devices and/or one or more other servers or data centers. In some variations, the computer system **500** can receive a transit request **552** from a client device of a user via the network link. The transit request **552** can include an identifier of the requester and target, as well as other information such as the transit type.

The computer system **500** can also include a display device **560**, such as a cathode ray tube (CRT), an LCD monitor, or a television set, for example, for displaying graphics and information to a user. One or more input mechanisms **570**, such as a keyboard that includes alphanumeric keys and other keys, can be coupled to the computer system **500** for communicating information and command selections to the processor **510**. Other non-limiting, illustrative examples of input mechanisms **570** include a mouse, a trackball, touch-sensitive screen, or cursor direction keys for communicating direction information and command selections to the processor **510** and for controlling cursor movement on the display **560**.

Examples described herein are related to the use of the computer system **500** for implementing the techniques described herein. According to one embodiment, those techniques are performed by the computer system **500** in response to the processor **510** executing one or more sequences of one or more instructions contained in the main memory **520**. Such instructions may be read into the main memory **520** from another machine-readable medium, such as the storage device **540**. Execution of the sequences of instructions contained in the main memory **520** causes the processor **510** to perform the process steps described herein. In alternative implementations, hard-wired circuitry may be used in place of or in combination with software instructions to implement examples described herein. Thus, the examples described are not limited to any specific combination of hardware circuitry and software.

FIG. 6 is a block diagram that illustrates a mobile computing device upon which embodiments described herein may be implemented. In one embodiment, a computing device **600** may correspond to a mobile computing device, such as a cellular device that is capable of telephony, messaging, and data services. The computing device **600** can correspond to a mobile computing device operated by a user or service provider. Examples of such devices include smartphones, handsets or tablet devices for cellular carriers. The computing device **600** includes a processor **610**, memory resources **620**, a display device **630** (e.g., such as a touch-sensitive display device), one or more communication sub-systems **640** (including wireless communication sub-systems), input mechanisms **650** (e.g., an input mechanism can include or be part of the touch-sensitive display device), and one or more sensors (e.g., a GPS component, an accelerometer, one or more cameras, etc.) **660**. In one example, at least one of the communication sub-systems **640** sends and receives cellular data over data channels and voice channels.

The processor **610** can provide a variety of content to the display **630** by executing instructions and/or applications that are stored in the memory resources **620**. For example, the processor **610** is configured with a target addressing software and/or logic **645** to perform one or more processes, steps, and other functions, including to communicate with a transit service to receive and render an instruction set such as described with any of the examples of FIG. 4A through FIG. 4C. Thus, target addressing logic **645** may include instructions, stored in memory **620**, that when executed, cause processor **610** to identify a target person. The target addressing logic **645** may also execute to cause the proces-

processor 610 to trigger the target device to generate location-relevant information 155, as described with examples of FIG. 1. As an addition or variation, the processor 610 may also execute target signaling logic 647, which enable the mobile computing device 600 to operate as the target device 157 (see FIG. 1) to communicate directly or indirectly with the provider device 92 and generate location-relevant information 155 (FIG. 1).

It is contemplated for examples described herein to extend to individual elements and concepts described herein, independently of other concepts, ideas or system, as well as for examples to include combinations of elements recited anywhere in this application. Although examples are described in detail herein with reference to the accompanying drawings, it is to be understood that the concepts are not limited to those precise examples. Accordingly, it is intended that the scope of the concepts be defined by the following claims and their equivalents. Furthermore, it is contemplated that a particular feature described either individually or as part of an example can be combined with other individually described features, or parts of other examples, even if the other features and examples make no mention of the particular feature. Thus, the absence of describing combinations should not preclude having rights to such combinations.

What is claimed is:

1. A method of implementing a network service, the method being performed by one or more processors and comprising:

communicating, over one or more networks, with (i) computing devices of users of the network service, and (ii) computing devices of drivers of the network service;

receiving, over the one or more networks, a request for a service from a computing device of a given user of the network service;

selecting an entrance from multiple entrances for a geographic area associated with the request for the service; determining a sequence of instructions for a driver of a vehicle to fulfill the request, the sequence of instructions including at least (i) an instruction to enter the geographic area at the selected entrance, and (ii) a vehicle stopping location; and

transmitting, over the one or more networks, the sequence of instructions to a computing device of the driver.

2. The method of claim 1, wherein the vehicle stopping location is on a transit route to a service location associated with the request.

3. The method of claim 1, wherein the request for service includes a target location within the geographic area.

4. The method of claim 3, wherein the sequence of instructions includes a set of delivery instructions for delivering a requested item to the target location.

5. The method of claim 3, wherein the one or more processors determine timing for the sequence of instructions until the driver arrives at the target location.

6. The method of claim 5, wherein each delivery instruction in the sequence of delivery instructions is provided at a pertinent time based on the timing as the driver performs the sequence of delivery instructions.

7. The method of claim 3, wherein the sequence of delivery instructions references one or more landmarks along a final portion of the service to guide the driver to the target location specified by the given user.

8. A computing system implementing a network service, the computing system comprising:  
one or more processors; and

a memory storing instructions that, when executed by the one or more processors, cause the computing system to: communicate, over one or more networks, with (i) computing devices of users of the network service, and (ii) computing devices of drivers of the network service;

receive, over the one or more networks, a request for a service from a computing device of a given user of the network service;

select an entrance from multiple entrances for a geographic area associated with the request for the service;

determine a sequence of instructions for a driver of a vehicle to fulfill the request, the sequence of instructions including at least (i) an instruction to enter the geographic area at the selected entrance, and (ii) a vehicle stopping location; and

transmit, over the one or more networks, the sequence of instructions to a computing device of the driver.

9. The computing system of claim 8, wherein the vehicle stopping location is on a transit route to a service location associated with the request.

10. The computing system of claim 8, wherein the request for service includes a target location within the geographic area.

11. The computing system of claim 10, wherein the sequence of instructions includes a set of delivery instructions for delivering a requested item to the target location.

12. The computing system of claim 10, wherein the one or more processors determine timing for the sequence of instructions until the driver arrives at the target location.

13. The computing system of claim 12, wherein each delivery instruction in the sequence of delivery instructions is provided at a pertinent time based on the timing as the driver performs the sequence of delivery instructions.

14. The computing system of claim 10, wherein the sequence of delivery instructions references one or more landmarks along a final portion of the service to guide the driver to the target location specified by the given user.

15. A non-transitory computer readable medium storing instructions for implementing a network service, wherein the instructions, when executed by one or more processors of a computing system, cause the computing system to:

communicate, over one or more networks, with (i) computing devices of users of the network service, and (ii) computing devices of drivers of the network service;

receive, over the one or more networks, a request for a service from a computing device of a given user of the network service;

select an entrance from multiple entrances for a geographic area associated with the request for the service; determine a sequence of instructions for a driver of a vehicle to fulfill the request, the sequence of instructions including at least (i) an instruction to enter the geographic area at the selected entrance, and (ii) a vehicle stopping location; and

transmit, over the one or more networks, the sequence of instructions to a computing device of the driver.

16. The non-transitory computer readable medium of claim 15, wherein the vehicle stopping location is on a transit route to a service location associated with the request.

17. The non-transitory computer readable medium of claim 15, wherein the request for service includes a target location within the geographic area.

18. The non-transitory computer readable medium of claim 17, wherein the sequence of instructions includes a set of delivery instructions for delivering a requested item to the target location.

19. The non-transitory computer readable medium of claim 17, wherein the one or more processors determine timing for the sequence of instructions until the driver arrives at the target location.

20. The non-transitory computer readable medium of claim 19, wherein each delivery instruction in the sequence of delivery instructions is provided at a pertinent time based on the timing as the driver performs the sequence of delivery instructions.

\* \* \* \* \*