

(19) World Intellectual Property Organization
International Bureau



(43) International Publication Date
1 March 2001 (01.03.2001)

PCT

(10) International Publication Number
WO 01/13989 A1

- (51) International Patent Classification⁷: A61N 1/32 (74) Agent: MCGOWAN, William, E.; Johnson and Johnson, One Johnson and Johnson Plaza, New Brunswick, NJ 08933 (US).
- (21) International Application Number: PCT/US00/23262
- (22) International Filing Date: 24 August 2000 (24.08.2000) (81) Designated States (national): AE, AG, AL, AM, AT, AU, AZ, BA, BB, BG, BR, BY, BZ, CA, CH, CN, CR, CU, CZ, DE, DK, DM, DZ, EE, ES, FI, GB, GD, GE, GH, GM, HR, HU, ID, IL, IN, IS, JP, KE, KG, KP, KR, KZ, LC, LK, LR, LS, LT, LU, LV, MA, MD, MG, MK, MN, MW, MX, MZ, NO, NZ, PL, PT, RO, RU, SD, SE, SG, SI, SK, SL, TJ, TM, TR, TT, TZ, UA, UG, UZ, VN, YU, ZA, ZW.
- (25) Filing Language: English
- (26) Publication Language: English
- (30) Priority Data:
60/150,636 25 August 1999 (25.08.1999) US
Not furnished 23 August 2000 (23.08.2000) US
- (71) Applicant: JOHNSON AND JOHNSON CONSUMER COMPANIES, INC. [US/US]; 199 Grandview Road, Skillman, NJ 08558-9418 (US).
- (84) Designated States (regional): ARIPO patent (GH, GM, KE, LS, MW, MZ, SD, SL, SZ, TZ, UG, ZW), Eurasian patent (AM, AZ, BY, KG, KZ, MD, RU, TJ, TM), European patent (AT, BE, CH, CY, DE, DK, ES, FI, FR, GB, GR, IE, IT, LU, MC, NL, PT, SE), OAPI patent (BF, BJ, CF, CG, CI, CM, GA, GN, GW, ML, MR, NE, SN, TD, TG).

(72) Inventors: SUN, Ying; 19 Woodville Terrace, Somerville, NJ 08876 (US). OAKESON, Ralph, W.; 8226 Slater Ave., Racine, WI 53406 (US). WISNIEWSKI, Stephen, J.; 6280 Pt. Pleasant Pike, Doylestown, PA 18901 (US). WANG, Jonas, C., T.; 23 Ellsworth Drive, West Windsor, NJ 08550 (US).

Published:

— With international search report.

For two-letter codes and other abbreviations, refer to the "Guidance Notes on Codes and Abbreviations" appearing at the beginning of each regular issue of the PCT Gazette.

(54) Title: TISSUE ELECTROPERFORATION FOR DRUG DELIVERY AND DIAGNOSTIC SAMPLING

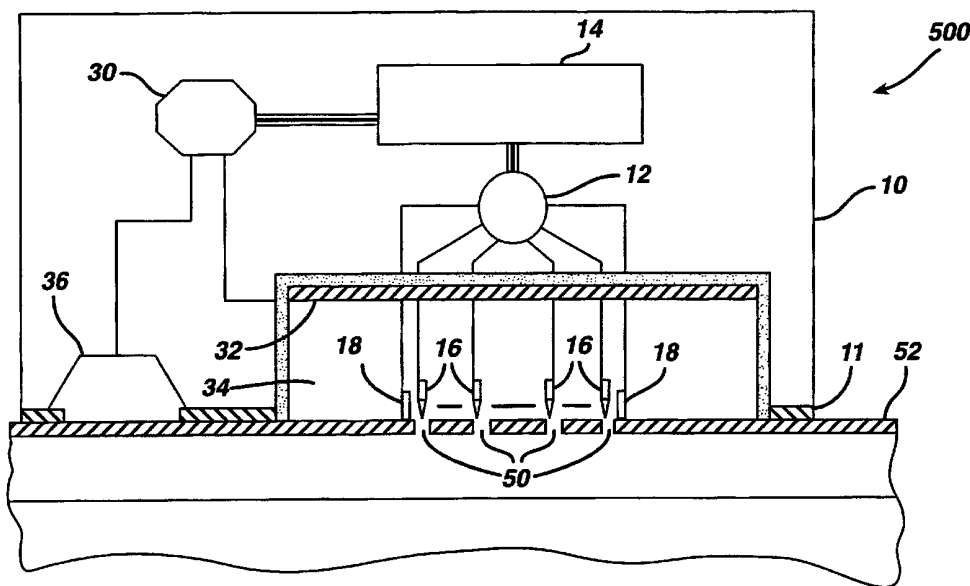

(57) Abstract: The present invention relates to a method and a device (500) for transporting a molecule through a mammalian barrier membrane (52) of at least one layer of cells comprising the steps of: ablating said membrane with an electric current from a treatment electrode; and utilizing a driving force to move said molecule through said perforated membrane.



WO 01/13989 A1

TISSUE ELECTROPERFORATION FOR DRUG DELIVERY AND DIAGNOSTIC SAMPLING**5 FIELD OF THE INVENTION**

The present invention relates to methods and devices for the ablation of barrier membranes using electric current in order to both enhance drug delivery for therapeutic purposes and enable sampling of biological
10 substances for diagnostic purposes.

BACKGROUND OF THE INVENTION

Transdermal and topical drug dosage forms have been widely prescribed for decades in the treatment of
15 systemic diseases and local conditions such as those involved with the skin and underlying tissues. These drugs are typically "easy-to-deliver" since they freely permeate through the skin or mucosal membrane with a high potency. Permeation of the drug across the skin or
20 mucosal membrane is a result of the chemical concentration gradient across the membrane. Examples of "easy-to-deliver" drugs include nitroglycerin, scopolamine, nicotine, hydrocortisone, betamethasone, benzocaine, and lidocaine.

25 Most drugs and biological active ingredients, however, do not easily permeate membranes and, therefore, are categorized as "difficult-to-deliver" drugs. Examples of "difficult-to-deliver" drugs include insulin, vasopressin, erythropoietin,
30 interferons, and growth hormone and its releasing factors. Typically, "difficult-to-deliver" drugs have high hydrophilicity and/or high molecular weight, such as polypeptides, proteins, and polynucleotides (e.g.,

genes). To increase skin permeation of these drugs, various chemical and physical permeation enhancing methods have been employed. This process, however, is usually only effective for drugs having relatively low
5 molecular weights (e.g., less than approximately 1000 daltons).

Electricity may be employed to facilitate drug transport across the membranes barrier by applying an electric potential gradient across the membrane to
10 facilitate drug transport. There are three such types of electrically facilitated drug transport methods, namely, iontophoresis, electro-osmosis, and electroporation. In iontophoresis, an ionized drug is driven across the membrane by an applied electric potential gradient. In
15 electro-osmosis, a non-ionic or poorly ionized drug is carried by a fluid that is driven across the membrane by an applied electric potential gradient. Electro-osmosis can also be used to extract interstitial fluid out of a body for diagnostic purposes. This process is called
20 "reverse iontophoresis." Electroporation is a process of creating transient microscopic pores on a barrier membrane, by extremely short pulses of high electric voltage and low current. U.S. Patent Nos. 5,019,034, 5,547,467, 5,667,491, and 5,749,847 describe an
25 "electroporation" method of treating a tissue in order to transiently increase the tissue's permeability to enhance molecular transport either for drug delivery or for sampling of interstitial fluids. All three of these transport methods are described by Sun in "Skin
30 Absorption Enhancement by Physical Means: Heat, Ultrasound, and Electricity," *Transdermal and Topical Drug Delivery Systems*, Interpharm Press, Inc., 1997, pages 327-355.

Although the above electrical methods can provide a powerful driving force for transdermal drug delivery, perforation of barrier membranes (e.g., the stratum corneum of the human skin) is still desirable to further facilitate drug transport. The following references disclose the disruption of the skin barrier membranes with mechanical means, i.e., with either small blades (i.e., microblades) or needles (i.e., microneedles): PCT Patent Applications WO 98/11937 and WO 97/48440; U.S. Patent Nos. 5,250,023 and 5,843,114; and Henry et al., "*Microfabricated Microneedles: A Novel Approach to Transdermal Drug Delivery*", S. Henry, D.V. McAllister, M.G. Allen and M.R. Prausnitz, *Journal of Pharmaceutical Sciences*, Vol. 8, August 1998, pages 922-925.

As an alternative approach, U.S. Patent No. 5,885,211 describes a method of enhancing the permeability of the skin utilizing microporation by using a hot metal wire heated by electric current. The disclosed "hot-wire" method for stratum corneum ablation comprises an ohmic heating element, namely, a material with high electric resistance that is heated up to very high temperature when an electric current passes through it. This "hot-wire" method described in this patent is similar to electrocautery commonly used in surgery to stop bleeding.

Radio Frequency ("RF") electric current has been used in electrosurgery for various surgical procedures. Electrosurgical machines produce high frequency alternating currents with frequencies of 500 kHz - 4000 kHz. These frequencies are part of the low RF range and produced by oscillating circuits. Advantages of electrosurgery, in comparison to other surgical

techniques, include simplicity of the technique, high speed, compact equipment, good safety, and applicable to both benign and malignant lesions.

Electrosurgery is different from electrocautery.

5 In eletrocautery, a metal wire that becomes heated as a result of its high resistance to the passage of direct current electricity is used to cut the tissue. The electric current does not pass through the tissue of a patient under treatment, but rather only through the
10 high resistance wire (the ohmic element) in order to heat it up. On the contrary, electrosurgery equipment, capable of producing RF electric current, are used to move or destroy tissue via a "cold" electrode, as described by S.V. Pollack, "Electrosurgery", in
15 *Dermatology*, Ed. S.L. Moschella and H.J. Hurley, W.B. Saunders Company, 1992, pages 2419-2431). In electrosurgery, the RF current passes through the patient tissue to produce intended heat to cause tissue disruption.

20 Previously published information regarding use of RF current in electrosurgery field has primarily been focused on the cutting and removing living tissues. The cutting depth is usually well into and often beneath the dermal tissues in dermatological and other surgeries. In
25 contrast, the present invention relates to the novel use of electric current to ablate a barrier membrane (e.g. the stratum corneum of the human skin) to both enhance drug delivery for therapeutic purposes and enable sampling of biological substances for diagnostic
30 purposes.

SUMMARY OF THE INVENTION

In one aspect, the present invention features a method for transporting a molecule through a barrier membrane of at least one layer of cells (e.g., the skin of a mammal such as a human) comprising the steps of: ablating the membrane (e.g., destroying the cells of the membrane) with an electric current from a treatment electrode; and utilizing a driving force to move the molecule through the perforated membrane (e.g., either moved into or out of the mammal through the membrane). Examples of membranes include, but are not limited to, skin, buccal, vaginal, and rectal membranes (e.g., of a human).

The transport processes associated with this invention lend themselves to use with a wide variety of molecules including drugs and molecules of diagnostic interest within the mammal. Molecules (e.g., compounds such as active agents) which may be delivered by the method and/or device of the present invention include, but are not limited to, any material capable of exerting a biological effect on a human body, such as therapeutic drugs, including, but not limited to, organic and macromolecular compounds such as polypeptides, proteins, saccharides, polysaccharides, polynucleotides, and nutrients.

In one embodiment the treatment electrode does not contact the membrane and an electric current forms an electric arc between the treatment electrode and the membrane. In another embodiment, the method further comprises the use of an indifferent electrode, where the electric current passes from the treatment electrode, through the membrane, and to the indifferent electrode.

Depending on the mode of an electroporation application, the two electrodes may or may not have direct contact with the skin.

The electric current may be a direct current, an
5 alternating current, or a mixture thereof. The frequency of the alternating current may be between about 30 Hz to about 10,000kHz (e.g., between about 60 kHz to about 5 MHz such as between about 100 kHz to about 4 MHz). The voltage of the current, the energy output, the
10 duration of the process, as well as the size, shape and number of the electroporation electrodes, may vary depending on the size and depth of the ablation required. The voltage may range from about 1 to about 2000 volts (e.g., 5 to 700 volts). The waveform of the
15 electric current may be a damped sine wave, modulated sine wave, pure sine wave, damped square wave, modulated square wave, pure square wave, direct current, or a blend wave thereof.

Examples of driving forces include, but are not
20 limited to: iontophoresis, electro-osmosis, reverse iontophoresis, and electroporation where a delivery electrode and a return electrode are used to transport the molecule through the membrane; phonophoresis where an ultrasonic transducer that converts electric energy
25 into acoustic energy to transport the molecule; pressure gradients where a mechanic apparatus that is capable generating either a positive or negative pressure gradient across the barrier membrane is used, respectively to move molecules into or out of the
30 mammal; heat where the increase in temperature enhances transport of the molecule; and concentration gradients where the higher concentration of the molecule one side

of the membrane causes its transport across the membrane.

In one embodiment, the method further comprises the step of piercing the membrane with a member selected
5 from the group consisting of needles or blades. In one embodiment, the method further comprises the step of applying a conductive material to the membrane prior the ablation. Examples of a conductive materials include, but are not limited to, electrolytes, metal particles,
10 or carbon particles. In one embodiment, the method further comprises the step of cooling and/or applying an analgesic to the membrane prior to or during the ablation. In one embodiment, the method further comprises the step of monitoring the electrical
15 resistance (e.g., impedance) of the membrane in order to determine the presence of ablation in the membrane.

In another aspect, the present invention features a device for transporting a molecule through a barrier membrane of a mammal comprising: a housing having a skin
20 contacting surface; a reservoir having an orifice in communication with the skin contacting surface; a current controller for making an electric current capable of ablating the membrane; and a treatment electrode proximate to the skin contacting surface for
25 delivering the current to the membrane where the treatment electrode is in electronic communication with the current controller; wherein upon contacting the skin contacting surface with the membrane, the device is capable of both ablating the membrane with the electric
30 current and transporting the molecule either from the reservoir, through the membrane, and into the mammal or from the mammal, through the membrane, and into the

reservoir. The treatment electrode may or may not come into contact with the membrane.

In one embodiment, the device comprises a plurality of treatment electrodes (e.g., between 2 and 200
5 treatment electrodes, such as between 2 and 50 treatment electrodes, per square centimeter of the electrode surface). In one embodiment, the device comprises an indifferent electrode which is used either as an return electrode when in contact with the membrane to complete
10 the electric circuit in bi-terminal electroporation, or, when not in contact with the membrane, to help directing the electric energy to the barrier membrane in the mono-terminal mode of electroporation. See S.V. Pollack, S.V.: "Electrosurgery", in *Dermatology*, Ed.
15 S.L. Moschella and H.J. Hurley, (W.B. Saunders Company, 1992), pages 2419-2431. In one embodiment, the device comprises a sensor for measuring the electrical resistance (e.g., impedance) of the membrane.

In one embodiment, the reservoir comprises an
20 iontophoretic electrode for drug delivery by iontophoresis and/or electro-osmosis, or for interstitial fluid sampling by reverse iontophoresis. In a further embodiment, the reservoir comprises a delivery electrode and a semipermeable membrane (e.g.,
25 permeable to the fluid within the reservoir, but not permeable to the molecule being transported through the membrane), wherein the semipermeable membrane separates the delivery electrode and the orifice. In one
embodiment, the reservoir further comprises a sensor
30 selected from the group consisting of sensors for measuring the pH, molecule or ion concentration, electric conductivity, amperage, and potential,

pressure, color and temperature of the fluid in the reservoir.

In one embodiment, the device further comprises a power supply (e.g., a battery) for providing a source of
5 electric current to the current controller from which the current controller modifies (e.g., via a circuit) the electric parameters of the current (e.g., the voltage, waveform, frequency, and duration) for use in ablating the membrane. In another embodiment, the
10 current controller is capable of being attached to an external power supply.

Other features and advantages of the present invention will be apparent from the brief description of drawings, the detailed description of the invention and
15 from the claims.

BRIEF DESCRIPTION OF THE DRAWINGS

FIG. 1 is a schematic representation of an example of an apparatus of the present invention that can be used
20 for the electroporation process under a "mono-terminal" condition.

FIG. 2a is a schematic representation of an example of an apparatus of the present invention that can be used for the electroporation process under a "bi-terminal"
25 condition, using one small treatment electrode and one large indifferent electrode.

FIG. 2b is a schematic representation of an example of an apparatus of the present invention that can be used for the electroporation process under a "bi-terminal"
30 condition, using two small, closely positioned electrodes parallel to the barrier membrane.

FIG. 2c is a schematic representation of an example of an apparatus of the present invention that can be used

for the electroporation process under a "bi-terminal" condition, using two closely positioned electrodes. The small treatment electrode is located closer to the membrane.

5 FIG. 3 is a schematic representation of an example of an apparatus of the present invention that can be used both for the electroporation process and for the transportation of a molecule through the perforated barrier.

10 FIG. 4 is a schematic representation of an example of an apparatus of the present invention with four electroporation electrodes that can be used for the electroporation process under a "mono-terminal" condition.

15 FIG. 5 is a schematic representation of an example of an apparatus that combines an electroporation unit with an iontophoresis unit. The electroporation unit has four electroporation electrodes that can be used for the electroporation process under a "mono-
20 terminal" condition. The iontophoresis unit is used for the transportation of a molecule through the perforated barrier.

 FIG. 6 is a schematic representation of an example of an apparatus of the present invention with a "roller-
25 like" shape.

 FIG. 7a is a top-view of a schematic representation of an example of an apparatus of the present invention having spacers.

 FIG. 7b is a cross-section view of a schematic
30 representation of an example of an apparatus of the present invention having spacers.

 FIG. 8 is a cross-section view of a schematic representation of some examples of electroporation

electrode tips that can be used in the apparatus of the present invention.

FIG. 9 shows typical microscopic biopsy results (magnification = 220X) of pig-skin treated with electroperforation.

FIG. 10 shows the blood glucose reduction in two pigs as a result from transdermal insulin delivery by iontophoresis through the skin treated with electroperforation.

10

DETAILED DESCRIPTION OF THE INVENTION

It is believed that one skilled in the art can, based upon the description herein, utilize the present invention to its fullest extent. The following specific embodiments are to be construed as merely illustrative, and not limitative of the remainder of the disclosure in any way whatsoever.

Unless defined otherwise, all technical and scientific terms used herein have the same meaning as commonly understood by one of ordinary skill in the art to which the invention belongs. Also, all publications, patent applications, patents, and other references mentioned herein are incorporated by reference.

In one aspect, the present invention relates to a method whereby it is possible to increase and control the transport of molecules across barrier membranes (e.g., tissues including mammalian skin and mucosal membranes such as rectal, vaginal, and buccal membranes) using an electric current to create openings (e.g., pores) in the membrane as transport pathways for the molecules. This method of ablating the barrier membrane is herein termed as "electroperforation." This ablation

of the membrane (e.g., the destruction of the layer of cells) is a result of the heat generated as the electric current passes through the membrane. As used herein, the term "pore" refers to a disruption of the membrane leading to an increased molecular transport. In this context, a pore is not restricted by its size and shape. For example, it may be a discrete hole having a diameter, for example, of between about 1 μ m to about 5mm (e.g., between about 10 μ m to about 1mm), or a line having a length, for example, up to about 10 cm (e.g., up to about 1 cm). An electroporation process may result in an array of such pores, a grid of the lines, or a mixture thereof.

Because the electroporation process in the present invention destroys the membrane at the point of application, this transport enhancement method is essentially independent of differences in membrane properties, either between different subjects or on the same subject but on the different anatomic sites. Examples of such differences include the chemical compositions of the membrane (e.g., lipid and ceramide contents), membrane thickness, mechanic properties (e.g., elasticity and toughness), and electric properties (e.g., conductivity), as well as biological characteristics (e.g., numbers and types of sweat glands and hair follicles). These differences are known to have a profound impact on transdermal drug delivery.

For example, stratum cornea with different lipid contents respond differently toward the use of chemical penetration enhancers that primarily affect lipid domain and pathways. Stratum cornea thickness affects most transdermal delivery relying on passive diffusion of drugs. Mechanical properties such as skin elasticity and

toughness dictate the outcome of mechanical ablation of stratum corneum utilizing methods described in PCT Patent Applications WO 98/11937 and WO 97/48440, U.S. Patent Nos. 5,250,023 and 5,843,114, and Henry et al.,

5 "Microfabricated Microneedles: A Novel Approach to Transdermal Drug Delivery", S. Henry, D.V. McAllister, M.G. Allen and M.R. Prausnitz, Journal of Pharmaceutical Sciences, Vol. 8, August 1998, pages 922-925.

Additionally, sweat glands and hair follicles are known

10 as primary pathways in transdermal drug delivery by iontophoresis. Since transdermal drug delivery through electroperforation with electric current eliminate these variables by creating new openings in the stratum corneum as drug transport pathways, this invention

15 provides a superior method for transdermal and transmucosal drug delivery over methods known in the prior arts.

Furthermore, the pores created by electroporation according the present invention are not transient (in

20 contrast to electroporation), but permanent in a sense these pores will remain open until the new cells re-grow over the opening. This result simplifies the drug delivery process by eliminating the need for constant monitoring the state of the transient microscopic

25 "pores" as in electroporation. Furthermore, in contrast to the electroporation process described in U.S. Patent No. 5,019,034, it is not necessary to have an electrolyte solution in the electrode chamber for the electroperforation of the present invention to take

30 place. In fact, a small air gap between the stratum corneum and the electrode tip may be used for eletrofulguration, as described below.

Furthermore, unlike the "hot wire" method described in U.S. Patent No. 5,885,211 which can not be used when the ohmic heating element is immersed in a liquid (e.g., a drug solution), the electroporation process of the present invention may be conducted in a liquid such as drug solution. It, therefore, is possible to repeat electric current treatment to the skin during a drug delivery process if the pores created previously have closed due to eventual tissue growth or other reasons.

In order to perform the electroporation process, any number of current generating devices may be used. Examples of suitable devices include electrosurgical devices currently on the market (e.g., Bovie® Specialist and Aaron 800™ both by Aaron Medical Industries, St. Petersburg, FL; Surgitron FFPF, Ellman International Inc., Hewlett, NY; and Hyfrector 2000, by ConMed Corporation, Englewood, CO). It should be noted that the electroporation apparatus can be fabricated into any shapes, sizes with various physical properties to suite various therapeutic applications. For example, as shown in Fig. 8, it can be made in the shape of a plate, a rod, a thin wire, a sharp needle, a blade, or a ball. The following publications describe the circuits, for generating electric currents for electrosurgery. These circuits can be used in the devices to be used for the electroporation process of the present invention: S.V. Pollack, S.V.: "Electrosurgery", in *Dermatology*, Ed. S.L. Moschella and H.J. Hurley, (W.B. Saunders Company, 1992), pages 2419-2431; K.H. Burdick in *Electrosurgery Apparatus and Their Applications in Dermatology*, Charles C. Thomas Publisher, 1966; J.A. Pearce in *Electrosurgery*, John Wiley & Sons, Inc., 1986; J.A.A. Langtry and A. Carruthers, "True Electrocautery in the

Treatment of Syringomas and Other Benign Cutaneous Lesions". *J Cutaneous Medicine and Surgery* 1997, 2:1:60-63; J.G. Levasseur, J.G. "Dermatologic Electrosurgery in Patients with Implantable Cardioverter-Defibrillators and Pacemakers", *Dermatologic Surgery* 1998, 24:233-240; J.E. Sebben in *Cutaneous Electrosurgery*, Chicago: Year Book Medical Publications, 1989; S.V. Pollack, in *Electrosurgery of the Skin*, New York: Churchill, Livingston, 1991; R. Usatine, et al. in *Skin Surgery: A Practical Guide*, Mosby, 1998; B.C. Schultz, in *Office Practice of Skin Surgery*, WB Saunders, 1985; C. Lawrence in *An Introduction to Dermatological Surgery*, Blackwell Science, 1996; and S. Burge in *Simple Skin Surgery*, Blackwell Science, 1996.

The following patent disclosures describe the circuit designs, electrode designs and application methods for electrosurgery and endoscopic procedures: U.S. Patent Nos. 5,451,224, 4,231,372, 5,282,799, 5,514,130, 5,785,705, 5,865,788, 5,545,161, 5,542,916, 5,540,681, 5,383,917, 5,125,928, 5,792,138, 4,071,028, 4,674,499, 4,805,616, 5,269,780, 5,693,052, 5,098,430, 4,979,948, 4,532,924, 5,785,705, 5,893,885, 5,906,613, and 5,897,553.

The outcome of an electroperforation process, such as the effects on a biological tissues and pore formation, is dependent upon the selection of the waveform, frequency, amperage, voltage, and the application technique of the electric current. All these criteria depend on circuit and electrode designs.

Further, the electric current for electroperforation in the present invention may be applied in a continuous or a discontinuous fashion.

There are five typical waveforms (i.e., electrofulguration, electrodesiccation, electrocoagulation, pure cut electrosection, and blend electrosection) used in electrosurgery as summarized in TABLE 1), all of which are also useful for the electroperforation in the present invention.

TABLE 1

<u>MODE OF APPLICATION (MODALITY)</u>	<u>WAVE FORM</u>	<u>APPLICATION TECHNIQUE AND BIOLOGICAL EFFECT</u>
Electro-fulguration	Damped sine wave form	No electrode-membrane contact; arc from electrode tip to membrane; Mono-terminal
Electro-desiccation	Damped sine wave form	Electrode-membrane contact; Mono-terminal
Electro-coagulation	Moderately Damped	Electrode-membrane contact; Bi-terminal
Electro-section Pure Cut	Pure sine wave	Electrode-membrane contact; Bi-terminal
Electro-section Blend	Modulated sine wave	Electrode-membrane contact; Bi-terminal

10 Visual diagrams of these waveforms are depicted on page 22 of Sebben, Cutaneous Electrosurgery (Year Book Medical Publishers, 1989). The waveforms may be generated by a spark gap circuit or an electronic circuit (e.g., a solid state circuit). See Pollack,
15 "Electrosurgery," in Dermatology, eds. Moscella, et al. (W.B. Sanders, 3d. ed. 1992). Other waveforms, such as any symmetric, asymmetric, or irregular waveforms (e.g.,

square waveform, damped square waveform, combination waveform of various waveforms and frequencies) may also be used for electroporation.

The terms "mono-terminal" and "bi-terminal" are used herein to describe the method of delivery of the current to the patient. Mono-terminal refers to the use of a treatment electrode without an indifferent electrode. True electrodesiccation and its variant, electrofulguration, are considered mono-terminal procedures. Bi-terminal denotes that both treatment and indifferent electrodes are used, as in electrocoagulation and electrosection. When utilizing a bi-terminal procedure, the treatment and indifferent electrodes can be in a concentric relation to each other, with the treatment electrode in the center and the indifferent electrode positioned concentrically around the treatment electrode. The indifferent electrode may have a much greater membrane contacting surface to help disperse the current. The two electrodes may also be placed apart (e.g., on the same or opposite sides of the membrane).

The measurement of the changes in the electric resistance or impedance of the barrier membrane undergoing the electroporation process can be used to provide an indication of the occurrence of electroporation with electric current, thereby providing a basis for selecting the magnitude and duration as well as the waveforms of the electric current. In one embodiment of this invention, the values and changes in values of the electrical impedance between a pair of electrodes, either during or after electric current treatment or treatment series, are monitored to allow a determination of the occurrence

and/or extent of electroporation for any tissue transport situation. More specifically, by monitoring the electrical resistance or impedance between a pair of electrodes, e.g., using a low level alternating current with a frequency between 100 Hz and 10,000 Hz, the mass transport resistance associated with low molecular weight ionic species such as sodium cations and chloride anions, which occur at naturally high concentrations in biological tissues, can be used to indicate the occurrence of electroporation.

The membrane site undergoing electroporation may also be pretreated to render it more electrically conductive to facilitate the electroporation. A topical composition containing conductive materials such as electrolytes or carbon and/or metal powders, in the form of solution, suspension, gel, cream, or lotion, may be applied to the membrane prior to the electroporation process. The compositions typically contain water, and may also contain organic solvents as vehicles. One example of such a preparation is a solution containing about 0.5 - about 5% NaCl, about 70% ethanol and/or isopropyl alcohol and about 29.5% - about 25% water. Alternatively, a conductive coating layer for the tissue, containing a film-forming polymer or gelling agent, may also be used for this purpose. One example of such a coating layer is a thin hydrogel or a hydrocolloidal gel layer containing electrolyte ions. One example of such a preparation is a gel containing about 1% hydroxypropyl cellulose, about 0.9% sodium chloride, and about 98.1% distilled water. Suitable gelling agents include, but are not limited to, agar, gelatin, pectins, gums (e.g., alginates, karaya gum, gum arabic, tragacanth gum, carrageenan gum, guar gum, gum

ghatti, locust bean gum, tamarind gum and xanthan gum),
and hydrophilic cellulose polymers (e.g.,
hydroxymethylcellulose, hydroxyethylcellulose,
hydroxypropylcellulose and carboxymethylcellulose),
5 polyacrylamide, polyethylene oxide, polyethylene
glycols, polypropylene glycols, polyvinyl alcohol,
polyvinylpyrrolidone, starch, polyacrylic acid,
polyacrylates, and derivatives, copolymers, and polymer
blends of aforementioned polymers. Other gelling agents
10 are listed in Hand of Water-soluble Gums and Resins,
eds. Crawford and Williams, (1980, McGraw-Hill, Inc.).

The tissue site undergoing electroperforation may
be cooled to a temperature below ambient temperature
prior to and during the electroperforation process in
15 order to minimize potential discomfort and living tissue
damage. The cooling process may be accomplished by
spraying a cryogenic liquid directly onto the membrane
prior to the electroperforation process. Examples of
cryogenic liquids include, but are not limited to,
20 fluorinated chlorinated hydrocarbons such as
tetrafluoroethane, ethyl chloride and ethyl fluoride,
dimethyl ether, propane, isobutane, liquid nitrogen, or
other liquefied gases.

The cooling may also be accomplished by contacting
25 the tissue with a heat sink device, which is made of a
heat conducting material (e.g., a metal) and contains a
cryogenic liquid. As the cryogenic liquid is allowed to
evaporate with a proper releasing mechanism (e.g.,
through a releasing valve), the temperature of the metal
30 is lowered. Alternatively, instead of using a cryogenic
liquid above, the heat sink may be cooled from
endothermic dissolution process, such as dissolving
certain materials (e.g., potassium or sodium nitrate,

urea) into water. The advantage of using a heat sink is that no direct contact is necessary between the cryogenic liquid and the tissue, thus avoiding potential side effects of the liquid such as tissue irritation.

5 An advantage of the electroperforation process is its ability to increase desired material transport across the barrier membrane which otherwise is rather impermeable. Thus, the present invention further pertains to a process of utilizing a driving force to
10 move molecules across the regions of the membrane undergoing, or having undergone, electroperforation with electric current. The driving force to move molecules across the perforated barrier membrane may be electrical in nature, such as iontophoresis, electro-osmosis,
15 reverse iontophoresis, or electroporation. The driving force may also be of acoustic energy in nature, such as in the case when ultrasound (i.e., frequencies above 20 kHz) or an audible sound (i.e., frequencies below 20 kHz) is used to enhance drug delivery (a process called
20 "phonophoresis"). The driving force may also be other physical or chemical force such as provided by a temperature gradient, a pressure gradient, or simply a concentration gradient (e.g., a concentrated form of the material to be transported is held in a reservoir
25 contacting the tissue surface at the site of electroperforation). With respect to the use of a concentration gradient, the driving forces of concentration difference in combination with an externally elevated hydrostatic pressure causes the
30 material to pass through the electroperforation-generated pores into the underlying tissue.

Thus, an electric force, in a form of iontophoresis, electroporation, electro-osmosis, or reverse

iontophoresis, can be used as the driving force to transport molecules across the tissue once the pores have been formed through electroporation. Simultaneously with or subsequent to the completion of

5 electroporation, an electrical potential of much lower voltage and greater duration for iontophoresis is applied to the electroporated skin site. Ions present in this low voltage field will migrate toward sources of opposite charge. Thus, if an electrode is present at another

10 distant site, oppositely charged drug ions will migrate through the pores created by electroporation into the body. Neutral molecules can also be moved by electro-osmosis for transdermal delivery or by reverse iontophoresis for interstitial fluid sampling. A single

15 apparatus in the present invention may have the build-in capability to operate several functions simultaneous or in sequence. Taking gene delivery to dermal tissue as an example, a three-step process may be conducted: (1) using electric current to create pores on stratum corneum by

20 electroporation, (2) applying iontophoresis to transport the genes across the stratum corneum into living epidermis and dermis tissues, and (3), applying electroporation to increase gene uptake into the epidermis and dermis cells by increasing cell membrane

25 permeability. The U.S. Patent Nos. 5,019,034, 5,547,467, 5,667,491, and 5,749,847 and PCT Patent Application WO 99/22809 describe the use of electroporation to increase tissue permeability. Iontophoresis and electroporation in the steps (2) and/or (3) may also be replaced by

30 phonophoresis.

The transport processes associated with this invention lend themselves to use with a wide variety of molecules including drugs and molecules of diagnostic

interest. Molecules (e.g., active agents) which may be delivered by the method and/or device of the present invention include, but are not limited to, any material capable of exerting a biological effect on a human body, such as therapeutic drugs, including, but not limited to, organic and macromolecular compounds such as polypeptides, proteins, polysaccharides, nucleic acid materials comprising DNA, and nutrients. Examples of polysaccharide, polypeptide and protein active agents include, but are not limited to, heparin and fragmented (low molecular weight) heparin, thyrotropin-releasing hormone (TRH), vasopressin, gonadotropin-releasing hormone (GnRH or LHRH), melanotropin-stimulating hormone (MSH), calcitonin, growth hormone releasing factor (GRF), insulin, erythroietin (EPO), interferon alpha, interferon beta, oxytocin, captopril, bradykinin, atriopeptin, cholecystokinin, endorphins, nerve growth factor, melanocyte inhibitor-I, gastrin antagonist, somatostatin, encephalins, cyclosporin and its derivatives (e.g., biologically active fragments or analogs).

Other examples of active agents include anesthetics, analgesics, drugs for psychiatric disorders, epilepsies, migraine, stopping drug additions and buses; anti-inflammatory agents, drugs to treat hypertension, cardiovascular diseases, gastric acidity and GI ulcers; drugs for hormone replacement therapies and contraceptives; antibiotics and other antimicrobial agents; antineoplastic agents, immunosuppressive agents and immunostimulants; and drugs acting on blood and the blood forming organs including hematopoietic agents and anticoagulants, thrombolytics, and antiplatelet drugs. Other active agents suitable for transdermal delivery to treat allergies are selected from the group consisting of

fine particles or extracts from natural substances (e.g., from herbs, grass seeds, pollens, and animal debris). Also, other cationic and anionic active agents, such as those described in M. Roberts, et al., "Solute Structure as a Determinant of Iontophoretic Transport", *Mechanisms of Transdermal Drug Delivery*, R.O. Potts and R.H. Guy, Ed., Marcel Dekker, pages 291-349, 1997, may be delivered with a device utilizing iontophoresis. Active agents that are non-ionized or with a net charge equal to zero may also be delivered with this apparatus by electro-osmosis as described by Pikal in "The role of Electroosmotic Flow in Transdermal Iontophoresis", *Advanced Drug Delivery Reviews*, pages 210-238, Vol. 9, 1992. Other active agents that may be used are disclosed in Mosby's Complete Drug Reference Physician's GenRx, ed. BeDell (Mosby-Year Book, Inc., 7th ed. 1997) and the Physicians Desk Reference (Medical Economics, 52nd Ed, 1998).

Similarly, molecules and substances of diagnostic interest, including both naturally occurring substances and therapeutically introduced molecules in interstitial fluid or blood if deeper penetration is desired, can be extracted out of the barrier membrane by electro-osmosis (reverse iontophoresis) for subsequent assaying. These molecules and substances include, but are not limited to, natural and therapeutically introduced metabolites, hormones, amino acids, peptides and proteins, polynucleotides, cells, electrolytes, metal ions, suspected drugs of abuse, enzymes, tranquilizers, anesthetics, analgesics, anti-inflammatory agents, immunosuppressants, antimicrobials, muscle relaxants, sedatives, antipsychotic agents, antidepressants, antianxiety agents, small drug molecules, and the like. Non-limiting representative examples of such materials

include glucose, cholesterol, high density lipoproteins, low density lipoproteins, triglycerides, diglycerides, monoglycerides, bone alkaline phosphatase (BAP), prostate-Specific-Antigen (PSA), antigens, lactic acid, pyruvic acid, alcohols, fatty acids, glycols, thyroxine, estrogen, testosterone, progesterone, theobromine, galactose, uric acid, alpha amylase, choline, L-lysine, sodium, potassium, copper, iron, magnesium, calcium, zinc, citrate, morphine, morphine sulfate, heroin, insulin, interferons, erythropoietin, fentanyl, cisapride, risperidone, infliximab, heparin, steroids, neomycin, nitrofurazone, betamethasone, clonidine, acetic acid, alkaloids, acetaminophen, and amino acids. In one embodiment, more than one substance is sampled at one time.

In one embodiment, the invention includes a continuous monitoring of the levels of glucose or glucose metabolite (e.g., lactic acid) from the body. The method can also be used for measurement of blood substance (glucose) levels in either a semi-continuous or a single measurement method. The method can be practiced by a device that provides electrodes or other means for applying electric current to the tissue at the collection site; one or more collection reservoirs or sampling chambers to receive the substance (glucose); and a substance concentration measurement system. U.S. Patent Nos. 5,735,273, 5,827,183, 5,771,890 describe the method of reverse iontophoresis for non-invasive interstitial fluid sampling for diagnostic purpose.

Interstitial fluid may also be extracted from the opening(s) created by electroperforation on the barrier membrane using one of the following methods: mechanical suction device with a structure similar to a syringe; a

pre-manufactured vacuum chamber with the working mechanism similar to the Vacumtainer® (Becton, Dickinson and Company, Franklin Lakes, NJ); placing on the opening(s) a capillary tube or an absorbent material (e.g., gauze or non-woven pad, sponge, hydrophilic polymers of porous structure); or combining
5 aforementioned methods. For example, interstitial fluid can be extracted out of the pore(s) following electroperforation using either a vacuum or an osmotic
10 pressure by contacting the perforated skin with a hygroscopic material such as glycerin, urea, polyvinylidone polymer either alone or as a concentrate aqueous solution. The glucose and other biological substances of interest in the extracted interstitial
15 fluid can be analyzed by the methods described in D. Buerk, Biosensors - Theory and Applications (Technomic Publishing Company, Inc., 1993), and in the U.S. Patent Nos 5,789,255, 5,453,360, 5,563,031, 5,304,468, 5,563042, and 5,843692.

20 After the interstitial fluid is driven out of the barrier membrane (e.g., the skin) through the opening(s) created by the electroperforation process by one or more aforementioned driving forces, analysis of certain biological substances in the interstitial fluid can be
25 performed with an analytical method such as a sensor based on enzymatic reaction, antibody interaction, ion-selective electrode, oxidation-reduction electrode; infrared (IR), ultraviolet (UV) spectrophotometry, or colorimetry.

30 The invention features an apparatus for performing the electroperforation methods of the present invention. One embodiment of an apparatus for producing the pores in a barrier membrane via electroperforation is

represented schematically in FIG.1. In FIG.1, the apparatus, represented generally as 100, comprises a housing 10, a current generator 14, a current controller 12, and a treatment electrode 16 for electroperforation in mono-terminal operation. The housing 10 may be fabricated from a variety of materials such as metal or plastics commonly used to fabricate the housings of medical devices. The current generator 14 may either comprise a power supply (e.g., a battery such as single use batteries made of alkaline, silver, lithium or high capacity batteries used in implantable electromedical devices; rechargeable Ni-Cd or other types of batteries) or can be connected to a power supply (e.g., plugged into a wall electrical outlet). The current controller 12 comprises a circuit that establishes and/or modifies the parameters of the electric current (e.g., the waveform, polarity, voltage, amperage, and duration) from the current generator 14.

In operation, the treatment electrode 16 is placed in contact with, or at a small distance from, the surface of the stratum corneum 52. The current generator 14 and the current controller 12, in communication with the treatment electrode 16, provides an electric current of a specific wave form, frequency, voltage, amperage, and duration to the treatment electrode 16. The electric current passes from treatment electrode 16 to the stratum corneum 52. As a result of the passing electric current, the stratum corneum 52, at the application site, is destroyed and a small pore 50 is formed. In one embodiment, there is no damage, or only minimal damage inflicted to the living tissues epidermis 54 and dermis 56.

The waveform, frequency, voltage, amperage, and duration of the electric current are controlled by current controller 12. The electric current may be applied for only a short period, such as less than 5
5 seconds (e.g., less than 1 second or less than 100 milliseconds), to accomplish a desired effect of electroperforation. The electric current may be also applied in a series of short pulses until the electroperforation is satisfactory. At that point, the
10 electroperforation process is completed, and the barrier membrane of the tissue is perforated (e.g., becoming permeable to the molecules to be delivered during a subsequent delivery process).

The resulting pore 50 serves as the transport
15 pathway for molecules of interest, such as a pharmaceutical for therapeutic treatment or interstitial fluid for diagnostic sampling. In the case of pore formation for sampling interstitial fluid, there can be a slightly more damage intentionally done by
20 electroperforation to the underlying living tissues so that more interstitial fluid or even blood can be collected through the pore 50.

In one embodiment, a second electrode (not shown), or the same treatment electrode 16, can be used to
25 monitor electrical resistance or impedance through stratum corneum 52. U.S. Patent No. 5,738,107 describes a method for impedance measurement and an electric circuit that can be used in this invention. Other impedance measurement circuits commonly used in
30 biomedical devices are also suitable for this purpose. The electrode for electric resistance/impedance measurement may be operatively connected to the current controller 12 and serve as a means for detecting the

electroperforation effect occurring during the electric current application. Thus, it serves to inform the current controller 12 of the time point at which the electroperforation process should be terminated and/or
5 reinstated. Since the stratum corneum contributes to almost all the electric resistance of the skin, prompt detection of the elimination of the electric resistance by electroperforation by the treatment electrode 16 or the additional electric resistance-detecting electrode
10 enables the current controller 14 to shut off the electric current in time to avoid any undesirable tissue damage.

Another embodiment of an electroperforation apparatus of the present invention, is represented
15 schematically in FIG. 2a. In FIG. 2a, the apparatus, represented generally as 200, comprises a housing 10, an electric current generator 14, an electric current controller 12, a treatment electrode 16 for electroperforation, and an indifferent electrode 20
20 (which may also be called "return electrode" or a "disperse electrode"). Apparatus 200, thus, is in bi-terminal operation. The apparatus operates much like that of the previous embodiment in FIG. 1, except that instead of being mono-terminal, which is suitable for
25 electroperforation by electrofulguration and electrodesiccation, the apparatus 200 works in bi-terminal operation, which is suitable for electroperforation by electrocoagulation and electrosection.

30 In operation, the treatment electrode 16 is placed in contact with, or at a small distance from, the surface of the stratum corneum 52. The indifferent electrode 20 is placed in contact with the surface of

the stratum corneum 52. The current generator 14 and the current controller 12, in communication with the treatment electrode 16 and indifferent electrode 20, provide an electric current of a specific wave form, 5 frequency, voltage, amperage, and duration to the treatment electrode 16. The electric current passes from treatment electrode 16, through the stratum corneum 52, and into the indifferent electrode 20. As a result of the passing electric current, the stratum corneum 52 at 10 the application site is destroyed and a small pore 50 is formed.

Another embodiment of an electroperforation apparatus of the present invention is represented schematically in FIG. 2b. It is a bi-terminal apparatus 15 with two electrodes 16 and 17, that are located very close to, but separated from, each other. Either electrode can serve as the indifferent electrode for the other. The primary effect on the membrane during electroperforation is limited to the area immediately 20 between the electrodes 16 and 17, thus confining the tissue action to a very limited area and not incorporating the person under treatment into the general circuit, and minimizing any potential side effects.

25 Another embodiment of an electroperforation apparatus of the present invention is represented schematically in FIG. 2c. Similar to the apparatus shown in FIG 2b, it is also a bi-terminal apparatus with two electrodes 16 and 18. The two electrodes share the same 30 supporting structure but are electrically insulated from each other. The treatment electrode 16 is located closer to the barrier membrane 52 than the indifferent electrode 18. This apparatus is suitable for

electroperforation conducted with the electrodes immersed in an electrically conductive solution (e.g., electrolyte solution or a solution containing an ionized drug). The electric current passes from treatment
5 electrode 16, through the barrier membrane stratum corneum, and returns to the indifferent electrode 18. As a result of the passing electric current, the stratum corneum 52 at the application site is destroyed and a small pore 50 is formed.

10 These apparatuses can be used to pre-treat a membrane by forming pores on the stratum corneum. Subsequent drug application to the pretreated membrane site can be any form of a pharmaceutical preparation, including but not limiting to, a solution, cream,
15 lotion, ointment, gel, spray, aerosol, powder, hydrogel, and a transdermal device in which the pharmaceutical is driven into the skin by a driving force including, but not limiting to, a concentration gradient, pressure gradient, electric force, and ultrasonic energy. For
20 diagnostic purposes, interstitial fluid can be collected from the mammal through the pores using means comprising negative pressure (e.g., a vacuum), electric force (e.g., reverse-iontophoresis), and ultrasound.

 Since the subsequent transdermal pharmaceutical
25 delivery method, or interstitial fluid sampling, can be accomplished using, electrical means (e.g., iontophoresis, electro-osmosis, reverse iontophoresis, and electroporation), it is possible to incorporate the components for these delivery devices into the
30 electroperforation apparatus.

 Thus, another embodiment of a drug delivery/diagnostic apparatus of the present invention, is represented schematically in FIG. 3. In FIG. 3, the

apparatus, represented generally as 300, comprises a housing 10, an electric current generator 14, an electric current controller 12, a treatment electrode 16 for electroperforation in mono-terminal operation, and a
5 sensor electrode 18 for detecting the change in electric resistance across the stratum corneum 52 (e.g., a decrease increase following electroperforation). Depending on the impedance signal obtained by the sensor 18, the electroperforation process can be terminated
10 after the opening 50 is successfully created and the impedance drops, or repeated until desirable results are obtained.

In a one embodiment, apparatus 300 may be used as a minimally invasive means for collecting interstitial
15 fluids for diagnostic purposes. After the electroperforation process is finished, and the interstitial fluids can be transported out of the tissue into the chamber 24 by negative pressure (e.g., a vacuum or osmotic pressure) or ultrasound (devices for
20 generating vacuum, osmotic pressure, or ultrasound not shown). To create an osmotic pressure to extract the interstitial fluid, a concentration amount of a solute species (e.g., highly water soluble salts, carbon hydrates including cellulose polymers and various
25 sugars, urea, solvents such as glycols, polyglycols and glycerol) may be placed in the chamber 24. The interstitial fluid can then be used in a variety of diagnostic procedures.

In another embodiment, the chamber 24 can be used
30 as a drug reservoir for drug delivery into the skin through the pore 50. A drug containing formulation (e.g., as a solution, gel, or any other pharmaceutically

acceptable form) can be placed in the chamber 24 for drug delivery purpose.

Apparatus 300 also comprises an adhesive layer 11 for affixing the device to the barrier membrane.

5 Suitable adhesive materials include those commonly used with medical devices and transdermal patches. The adhesive may be a polymeric, pressure sensitive and nonconductive and remains adherent even after prolonged exposure to water. Typically, the adhesive has a broad
10 working temperature range. Suitable adhesive materials include, but are not limited to, silicones, polyisobutylenes and derivatives thereof, acrylics, natural rubbers, and combinations thereof. Suitable silicone adhesives include, but are not limited to, Dow
15 Corning[®] 355 available from Dow Corning of Midland, MI; Dow Corning[®] X7-2920; Dow Corning[®] X7-2960; GE 6574 available from General Electric Company of Waterford, NY; and silicone pressure sensitive adhesives, such as those disclosed in U.S. Patent Nos. 2,857,356,
20 4,039,707, 4,655,767, 4,898,920, 4,925,671, 5,147,916, 5,162,410, and 5,232,702. Suitable acrylic adhesives include, but are not limited to, vinyl acetate-acrylate multipolymers, including, such as Gelva[®] 7371, available from Monsanto Company of St. Louis, MO; Gelva[®] 7881;
25 Gelva[®] 2943; I-780 medical grade adhesive available from Avery Dennison of Painesville, OH; and acrylic pressure sensitive adhesives, such as those disclosed in U.S. Patent Nos. 4,994,267, 5,186,938, 5,573,778, 5,252,334, and 5,780,050. Alternative affixing methods, such as an
30 elastic or Velcro[®] strap may also be used. Another embodiment of an apparatus of the present invention, represented generally as 400 having housing 10, contains multiple treatment electrodes 16 for electroperforation

as shown in FIG. 4. Such an array of electroporation electrodes allows a large area of skin 52 to be perforated with multiple pores 50 in a timely manner by the electroporation apparatus 400. The treatment electrodes 16 may operate either simultaneously or in sequence, as controlled by the current generator 14 and the electric current controller 12. Apparatus 400 also comprises multiple sensor electrodes 18.

Since the subsequent transdermal pharmaceutical delivery method, or interstitial fluid sampling, can be accomplished using, electrical means (e.g., iontophoresis, electro-osmosis, reverse iontophoresis, and electroporation), it is possible to incorporate the components for these delivery devices into the electroporation apparatus.

Thus, another embodiment of the apparatus of the present invention, represented generally as 500 in FIG. 5, a transdermal iontophoresis device is incorporated into the electroporation apparatus. The combination apparatus 500, capable of providing both electroporation and iontophoresis, comprises a housing 10, adhesive layer 11, an electric current generator 14, an electric current controller 12, treatment electrodes 16 for electroporation, sensor electrodes 18 for skin resistance detection, a chamber 34 as a drug/interstitial fluid reservoir, a delivery electrode 32 as a conductive electrode for iontophoretic drug delivery, a return electrode 36 to complete the circuit with iontophoretic electrode 32 for iontophoresis operation, and an iontophoresis control unit 30, in communication with the current generator 14, the conductive electrode 32 for iontophoresis, and the return electrode 36.

The iontophoretic drug delivery may be conducted following, or simultaneously with, the electroperforation process. U.S. Patent Nos. 4,301,794, 4,406,658, 4,340,047, 4,927,408, 5,042,975, and 5,224,927 describe the process of iontophoretic delivery of a substance across tissue that can be used in the present invention.

For delivering a drug through pores 50 in membrane 54, a drug solution may be present or absent during the electroperforation process. In the latter case, the drug solution may be subsequently placed into the chamber 34 (e.g., either through a septum with a syringe or through a port on the wall of the chamber 34 from a breakable capsule (neither shown)) after the electroperforation process is completed.

There may be an optional semipermeable membrane to separate the chamber 34 horizontally into two sub-chambers (not shown). The upper sub-chamber thus created serves as the iontophoresis electrode chamber (containing delivery electrode 32) and the lower sub-chamber serves as the drug reservoir that is in communication with the membrane surface. The semipermeable membrane has pores smaller than the drug molecules being delivered so that the drug molecules can not pass through the semipermeable membrane from the drug reservoir into the iontophoresis electrode chamber (e.g., to be deactivated by the delivery electrode 32).

The combination apparatus 500 may also contain sensors (e.g., sensors for measuring the pH, molecule or ion concentration, electric conductivity, amperage, and potential, pressure, color and temperature of the fluid in chamber 34 (not shown)) to assist in achieving optimal iontophoresis operation. The iontophoresis

operation may also use a reverse polarity mode, such as described in U.S. Patent Nos. 4,406,658, 4,301,794, 4,340,047, and 5,224,927.

In yet another embodiment of the present invention, the electroperforation apparatus may be constructed in a form of a "roller-like" device, represented generally as apparatus 600 in FIG. 6. The handle 70 of the roller-like electroperforation apparatus 600 comprises an electric current controller and an electric current generator. The arms 80 are built comprise the connecting wires allowing electric communication between the current controller and current generator in the handle 70 and the electrode array 96 on the roller 90. The body of the roller 90 may contain both an array of treatment electrodes for electroperforation and an array of sensor electrodes for skin resistance detection. It may also contain an iontophoresis unit, as described above.

The "roller-like" electroperforation apparatus 600 is used to create pores on the barrier membrane of a patient. When the apparatus rolls over a skin area, the electroperforation process occurs as the roller surface comes in contact with the membrane, resulting in the formation of numerous pores at pre-determined intervals for a subsequent drug application. The advantages of such an apparatus include an easy and rapid operation over a large membrane area with complex contours.

Alternatively, an electroperforation device in FIG 6 may be fabricated into a "stamp-like" device where the roller is replaced with a flat or nearly flat surface on which to electrodes are located. In operation, this "stamp-like" electroperforation device can be used to electroperforate the membrane by pressing the surface against the membrane.

In yet another embodiment of the electroporation apparatus of the present invention, the treatment electrodes 16 may be placed within a spacers 42 as shown in FIG. 7. The function of spacers 42 is two fold: (a) 5 separating the treatment electrodes 16 from each other at a predetermined distance and (b) providing a precise distance between the tips of the treatment electrodes 16 and the barrier membrane (e.g., the stratum corneum) 32 to be electroporated. For example, when 10 electrofulguration or electrodesiccation is the mode of action for an electroporation process, there should be no direct contact between the treatment electrode 16 and the stratum corneum 32, but rather only a predetermined small gap as controlled by the spacers 42. With other 15 modes of action, such as electrocoagulation and electrosection, the treatment electrode 16 should contact the tissue. In these cases, the spacers 42 prevent undesirable damages to the deeper tissues 34 and 36 other than stratum corneum 32. The open areas 40 provide the 20 liquid pathways for a drug solution to reach the stratum corneum openings 50 from the drug reservoir.

It should be noted that the relative ratio of the open areas 40 to the areas occupied by the spacers 42 and electrodes 16 will vary depending on a particular need. 25 The shapes of the electrodes 16, spacers 42 and the openings 40 may also vary significantly. For example, the tip or the working area of the electrode 16 may be sharply pointed, dull pointed, rounded, blade-like, symmetric or asymmetric, flat, irregularly shaped, with 30 smooth or rough surface. The material used for the electrode 16 may be pure metal, metal alloy, carbon, ceramic, or other any other conductive materials such as conductive composites (e.g., metal-polymer, carbon-

polymer, metal-glass, and metal-ceramic) suitable for making the electrodes.

In another embodiment of the invention, the treatment electrode may be made of a consumable material, which is either burned out or melted away during the electroperforation process. For example, when current passes through a thin carbon rod or a carbon fiber to the barrier membrane during the electroperforation process, the heat generated burns out the carbon electrode, thus automatically cutting off the current. This can act as a safety measure to prevent any excess burning which could result from potential malfunction of the current controller. The use of such a consumable electrode to self-terminate the current can also serve as a means to control the duration of electroperforation. Other consumable electrode materials include low melting point metal alloys and metal-polymer composites.

In another embodiment of the invention, the electroperforation electrodes are fabricated as needles or blades. In operation, stratum corneum is first treated by electroperforation. Then the sharp electrodes can be pressed against the electroperforated stratum corneum to further disrupt it. In this case, because it is not necessary to completely perforate the stratum corneum with electric current, a much lower energy power can be used to denature the barrier membrane to make it easier to be penetrated by the needle or blade.

In another embodiment of the invention, the electroperforation process can be conducted while the electrodes are immersed in the drug solution, so that the drug delivery process starts immediately following electroperforation. The electroperforation process can

be repeated when necessary (e.g., as indicated by the sensors discussed above).

In another embodiment of the invention, the electroperforation process may be conducted simultaneously with all the treatment electrodes (e.g., the electrodes in the electrode array shown in FIG. 7). Alternatively, the electroperforation process may be conducted using only one or a few of electrodes at a given time, and then proceeding stepwise with the other electrodes (e.g., in a fashion resembling a "scanning" action). The mode of turning select electrodes on or off may be controlled by the current controller (e.g., current controller 12 in FIGS 1-5). The advantage of the "scanning" mode of action is the minimal amount of electric energy required, thus minimizing any potential side effects.

In another embodiment of the invention, a further step is used to retard the closure of the pores (e.g., by keeping the pores occluded for drug delivery or interstitial fluid sampling). In one embodiment, the pores are kept in an aqueous solution that may also contain the drug to be delivered and/or contain compounds that retard epidermal cell differentiation or the tissue growth leading to the closure of the pores. Examples of such compounds include, but are not limited to, saccharides, polysaccharides, cyclodextrins, heparin and fragmented (low molecular weight) heparin derivatives.

To evaluate the feasibility of using electroperforation as a permeability enhancing method to increase transport across a barrier membrane such as the skin, several electroperforation experiments were

conducted to examine molecular transport of drugs and water through pig skin *in vivo*.

Example 1. Increase in Transepidermal Water Loss (TEWL)
5 after Electroporation in Pigs

To evaluate the pore transport pathway created through the stratum corneum of the skin by electroporation, an *in vivo* experiment was conducted on the back skin of Yorkshire pigs (female, ~12 kg) using
10 an electrosurgery apparatus (Surgitron™, Ellman International, Inc., Hewlett, NY). The pigs were immobilized with appropriate anesthetics and analgesics. Electrofulguration current was used with a fine wire
15 electrode (0.26 mm in diameter) and power output setting at between scale 3 to 10. A small pore was created on the surface of the skin by carefully moving the electrode towards the skin until the tip of the electrode almost touched the skin. The electrode was quickly moved away
20 from the skin as soon as an electric arc appeared in the gap between the electrode tip and the skin surface.

Typical microscopic biopsy results (magnification = 220X) of the pig skin treated with electroporation are shown in FIG. 9. FIG. 9a shows a pore (~64 micrometers) created by electroporation through the stratum corneum
25 10 with a minimal damage to the underlying living epidermis 20. FIG. 9b shows a pore that perforated through both stratum corneum 10 and living epidermis 20, but not dermis 30. These results show the flexibility of the electroporation process of the present invention.
30 Desired depths of tissue perforation may be achieved with the modification of the power and duration of the electric current. For example, stratum corneum perforation may be suitable for transdermal drug

delivery, while perforation through the epidermis, or even some part of dermis, may be suitable for interstitial fluid sampling or vaccination.

Transepidermal water loss (TEWL) was also measured
5 on the skin site of electroperforation with Evaporimeter®
EP1 (Servomed AB, Stockholm, Sweden). Four measurements were made for each condition. TEWL measurement is well-known in the field of transdermal drug delivery and
10 cosmetic industry as a good indicator for stratum corneum integrity. An increase in TEWL value implies disrupted stratum corneum.

In this experiment, TEWL measurements were conducted as a function of the pores created on the pig skin. We found that as the number of the pores created by
15 electroperforation increased, the TEWL value increased almost proportionally. This result demonstrates that the electroperforation procedure successfully produced pores across the stratum corneum, through which water molecules escaped from the pig body to the outside. This result
20 further demonstrates that interstitial fluid may be extracted through the pores created by electroperforation, and analyzed for its biological substances for diagnostic purposes. Other techniques such as vacuum may be used to aid the interstitial fluid
25 extraction.

Example 2. Electroperforation Followed by Passive Diffusion of Insulin for Transdermal Delivery

The electroperforation procedure described in
30 Example 1 was conducted in two pigs with a pore density of 39 pores/cm² of the skin and subsequently followed by transdermal insulin delivery with passive diffusion. An insulin-containing chamber was immediately placed onto

the electroperforation-treated skin. The chamber was made of flexible polyethylene containing 0.5 ml of insulin injection solution (Pork insulin, Molecular Weight \cong 6000 daltons, 100 U/ml, Regular Iletin® II, Eli Lilly, Indianapolis, IN). The contact area of the insulin solution in the chamber to the electroperforation-treated skin was 2.3 cm². The chamber was affixed to the pig skin with a veterinary silicone adhesive at the rim of the chamber. Blood glucose of the pigs was monitored by obtaining blood samples of the ear vein, which were analyzed using two blood glucose analyzers separately to assure the accuracy (One Touch® Basic, LifeScan, Inc., Milpitas, CA). The blood glucose levels in both pigs declined rather quickly from the onset of the insulin delivery experiment. The significant blood glucose reduction (greater than 50% of the basal level) indicates that insulin from the drug-containing chamber indeed passed through the pores on the stratum corneum into the body and entered the systemic blood circulation, resulting in the severe hypoglycemia in these pigs.

Example 3. Electroperforation followed by Iontophoresis of Insulin for Transdermal Delivery

An electroperforation procedure was conducted in two pigs similar with a pore density of 9 pores/cm² on the skin and subsequently was followed by transdermal insulin delivery. The purpose of using a lower pore density in this experiment was to examine the effect of pore number (e.g., the extent of the transport pathway available) to transdermal insulin delivery. The same insulin-containing chamber and drug application procedures were used in this experiment as those in the Example 2. However, a steel wire was placed in the insulin-containing chamber to

serve as a delivery electrode for iontophoresis. The power source of iontophoresis was a commercial iontophoresis apparatus (Phoresor II™, PM700, Motion Control, Inc., Salt Lake City, Utah). The first 1.5 hours of the delivery experiment was by passive diffusion of insulin only. Iontophoresis of insulin was conducted twice in two 30-minute sections with 4 mA DC current at 1.5 hour and 3 hour, respectively, as indicated by the arrows in FIG. 10. The electric polarity of the conductive electrode was reversed every 5 minutes to prevent pH shifting of the drug solution in the chamber.

FIG. 10 shows that the blood glucose levels in both pigs did not decline during the first 1.5 hours of passive diffusion. The result implies that the limited transport pathway available with 9 small pores per cm^2 in the stratum corneum might not be enough to deliver insulin and to produce a therapeutically significant blood glucose reduction via passive diffusion (e.g., merely utilizing a concentration gradient). On the other hand, rapid blood glucose reduction during iontophoresis indicates insulin was delivered into the pigs during this time. This result shows that even with limited disruption of stratum corneum, additional driving forces such as iontophoresis can still deliver a macromolecular drug into the skin to exert its therapeutic efficacy.

This result shows the possibility of making a very small transdermal delivery device (e.g., smaller than 1 cm^2 or even 0.1 cm^2). All the transdermal drug delivery patches currently available are much greater in size (e.g., $10\text{-}40 \text{ cm}^2$). Such a small size transdermal device would be much more discrete and comfortable for a patient to wear, and would reduce the potential of skin

irritation due to skin response to these adhesive-containing devices and prolonged occlusion.

Example 4. Electroporation followed by Passive
5 Diffusion of Erythropoietin for Transdermal Delivery

An electroporation procedure was conducted in two pigs similar to that in Example 3, followed by passive diffusion of erythropoietin (20kU/ml, Procrit®, Ortho Biotech, Inc., Raritan, NJ) at the treatment site.
10 There were 25 pores/cm² generated with electroporation on each pig. The drug chamber based over the electroporation-treated skin area contained 0.5 ml of erythropoietin solution. Blood samples were collected for erythropoietin analysis with an ELISA method. The
15 erythropoietin delivery procedure was carried out for 7 hours. The drug-containing chamber was removed at the end of the delivery procedure, but the blood sampling was continued for up to 30 hours following the start of the experiment. It was found that there was a
20 progressive increase in plasma erythropoietin concentration until the drug-containing chambers were removed from the skin of the pigs. One day after the delivery experiment, the plasma erythropoietin concentrations in the pigs were still above the
25 endogenous basal level

It is understood that while the invention has been described in conjunction with the detailed description thereof, that the foregoing description is intended to illustrate and not limit the scope of the invention,
30 which is defined by the scope of the appended claims. Other aspects, advantages, and modifications are within the claims.

What is claimed is:

CLAIMS

1. A method for transporting a molecule through a mammalian barrier membrane of at least one layer of cells comprising the steps of:

ablating said membrane with an electric current from a treatment electrode; and

utilizing a driving force to move said molecule through said perforated membrane.

10

2. A method of claim 1, wherein said electric current forms an electric arc between said treatment electrode and said membrane.

15

3. A method of claim 1, wherein said method further comprises the use of an indifferent electrode, where said electric current passes from said treatment electrode to said indifferent electrode.

20

4. A method of claim 1, wherein said electric current comprises a direct current.

5. A method of claim 1, wherein said electric current comprises an alternating current.

25

6. A method of claim 1, wherein said electric current has a frequency of between about 60kHz to about 5,000kHz.

30

7. A method as in claim 1, wherein the waveform of said electric current is selected from the group consisting of damped sine wave, modulated sine wave,

pure sine wave, damped square wave, modulated square wave, pure square wave, direct current and a blend wave thereof.

5 8. A method of claim 1, wherein said membrane is selected from the group consisting of skin, buccal, vaginal, and rectal membranes.

 9. A method of claim 8, wherein said membrane is
10 the stratum corneum of a human.

 10. A method of claim 1, wherein said driving force is selected from a group consisting of iontophoresis, electro-osmosis, reverse iontophoresis,
15 electroporation, phonophoresis, pressure gradients, heat and concentration gradients.

 11. A method of claim 1, wherein said molecule is a pharmaceutical transported through said membrane into
20 said mammal.

 12. A method of claim 11, wherein said pharmaceutical is selected from the group consisting of polysaccharides, peptides, proteins, and
25 polynucleotides.

 13. A method of claim 1, wherein said molecule is transported from within said mammal out through said
membrane.

30

 14. A method of claim 1, further comprising the step of piercing said membrane with a member selected from the group consisting of needles or blades.

15. A method of claim 1, further comprising the step of applying a conductive material to said membrane prior to said ablation.

5

16. A method of claim 15, wherein said conductive material is selected from the group consisting of electrolytes, metal particles, and carbon particles.

10

17. A method of claim 1, further comprising the step of cooling said membrane prior to or during said ablation.

15

18. A method of claim 1, further comprising the step of applying an analgesic to said membrane prior to or during said ablation.

20

19. A method of claim 1, further comprising the step of monitoring the electrical resistance or impedance of said membrane in order to determine the presence of ablation in said membrane.

25

20. A device for transporting a molecule through a barrier membrane of a mammal comprising:

a housing having a skin contacting surface;

a reservoir having a orifice in communication with said skin contacting surface;

a current controller for making an electric current capable of ablating said membrane; and

30

a treatment electrode proximate to said skin contacting surface for delivering said current to said membrane where said treatment electrode is in electronic communication with said current controller;

wherein upon contacting said skin contacting surface with said membrane, said device is capable of both ablating said membrane with said electric current and transporting said molecule either from said
5 reservoir, through said membrane, and into said mammal or from said mammal, through said membrane, and into said reservoir.

21. A device of claim 20, wherein the device
10 comprises a plurality of treatment electrodes.

22. A device of claim 20, wherein said delivered current comprises an alternating current.

15 23. A device of claim 22, wherein said delivered current has a frequency of between about 60kHz to about 5,000kHz.

24. A device as in claim 20, wherein the waveform
20 of said delivered electric current is selected from the group comprising damped sine wave, modulated sine wave, pure sine wave, damped square wave, modulated square wave, pure square wave, direct current, and a blend wave thereof.

25 25. A device of claim 20, wherein said device comprises an indifferent electrode.

26. A device of claim 20, said device further
30 comprising a sensor for monitoring the electrical resistance or impedance of said membrane.

27. A device of claim 20, wherein said reservoir comprises an iontophoretic electrode.

28. A device of claim 27, wherein said reservoir
5 comprises a delivery electrode and a semipermeable membrane, wherein said semipermeable membrane separates said delivery electrode and said orifice.

29. A device of claim 27, wherein said reservoir
10 further comprises a sensor selected from the group consisting of sensors for measuring the pH, molecule or ion concentration, electric conductivity, amperage, and potential, pressure, color and temperature of fluid in said reservoir.

15

30. A device of claim 20, wherein said device comprises a battery in electronic communication with said current controller.

FIG. 1

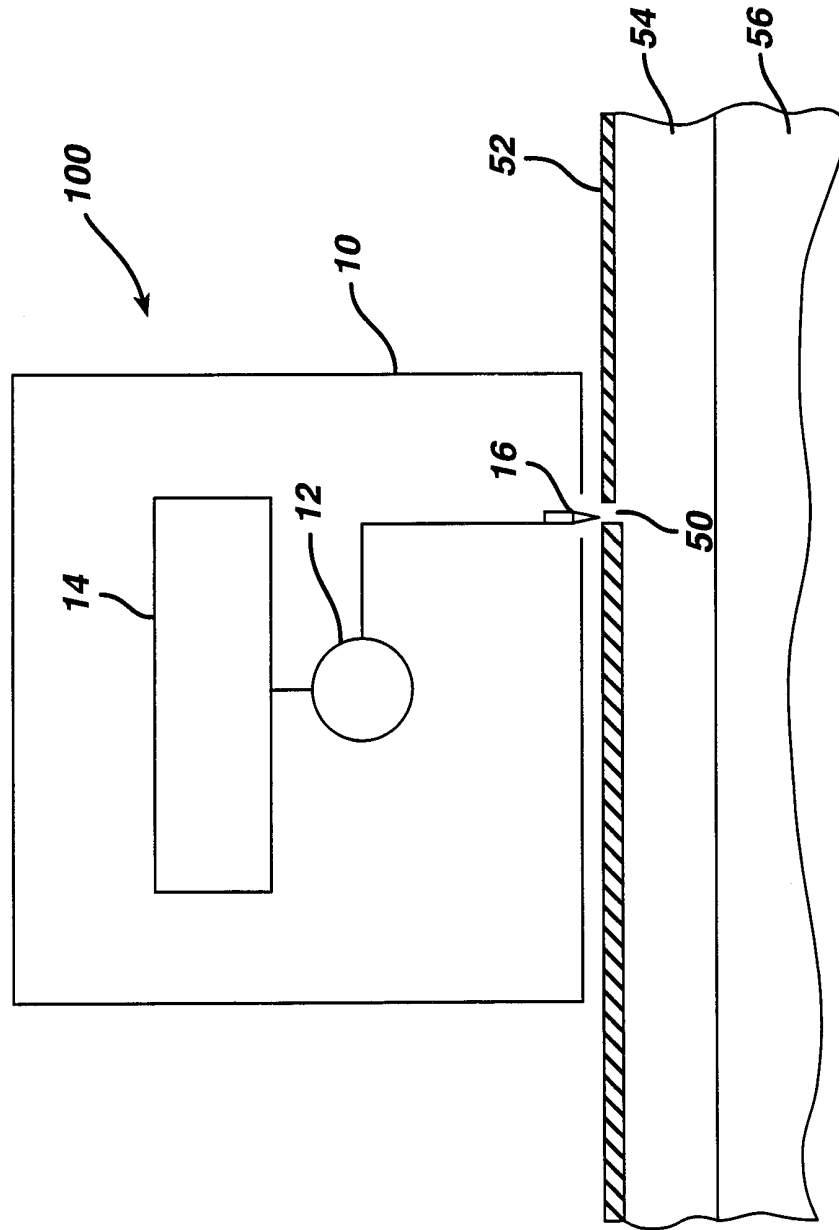

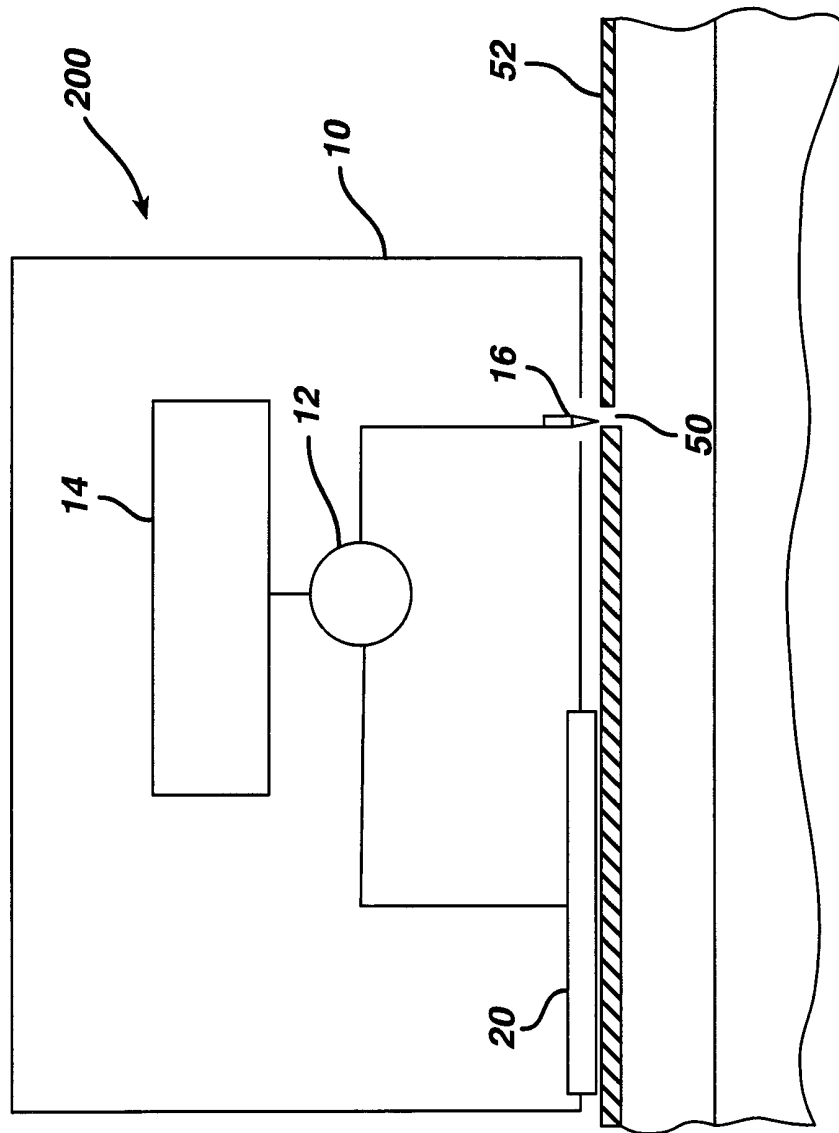

FIG. 2a

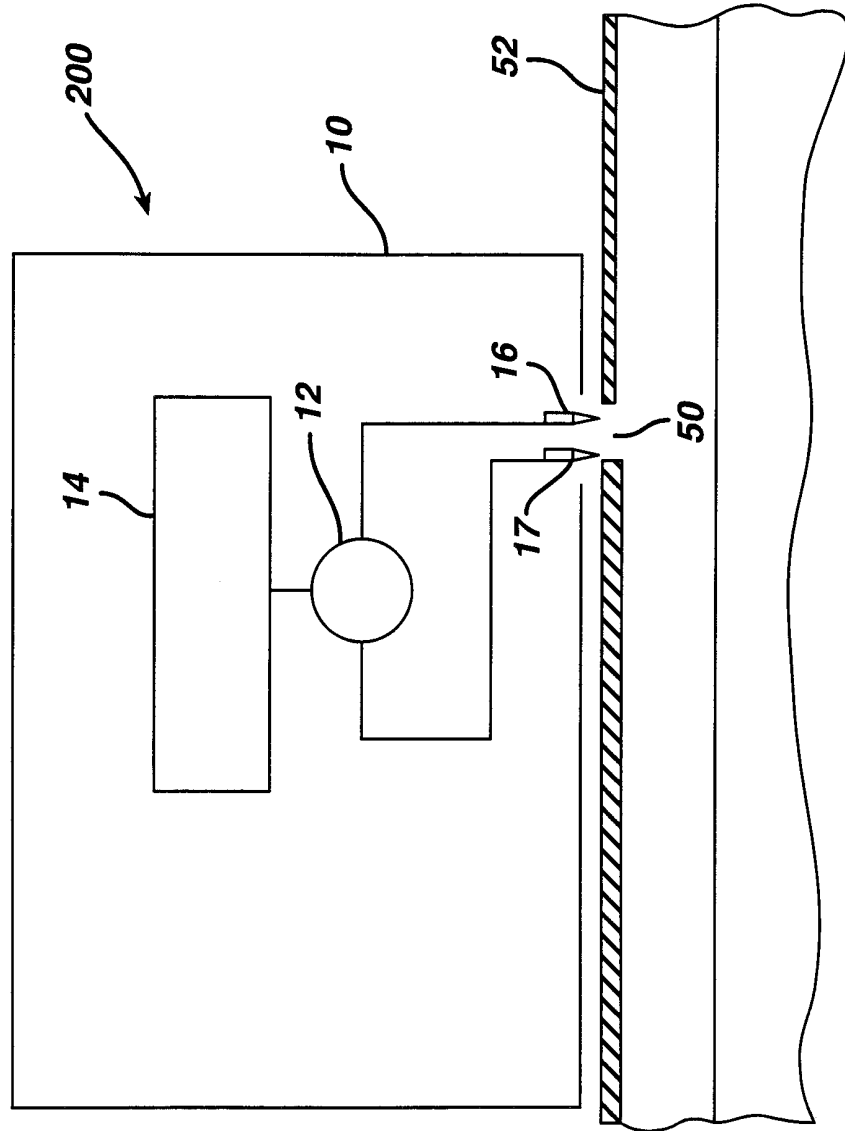

FIG. 2b

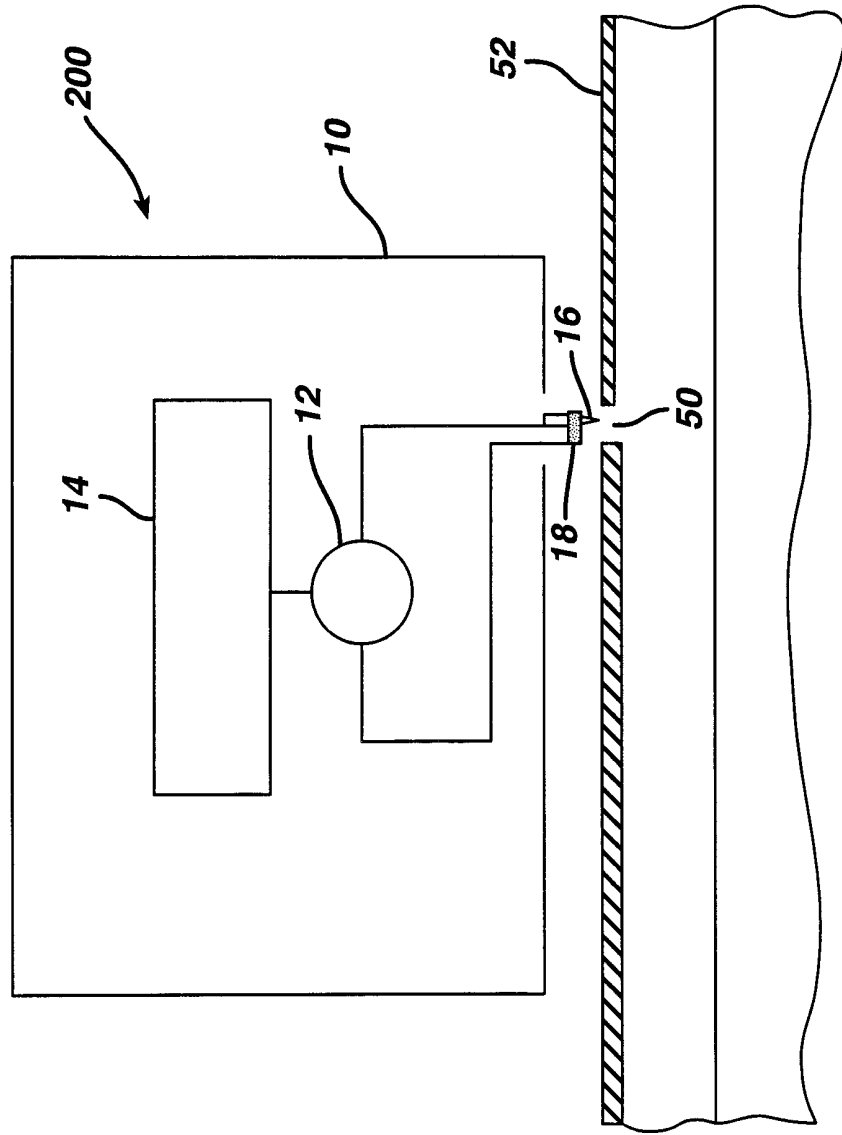

FIG. 2C

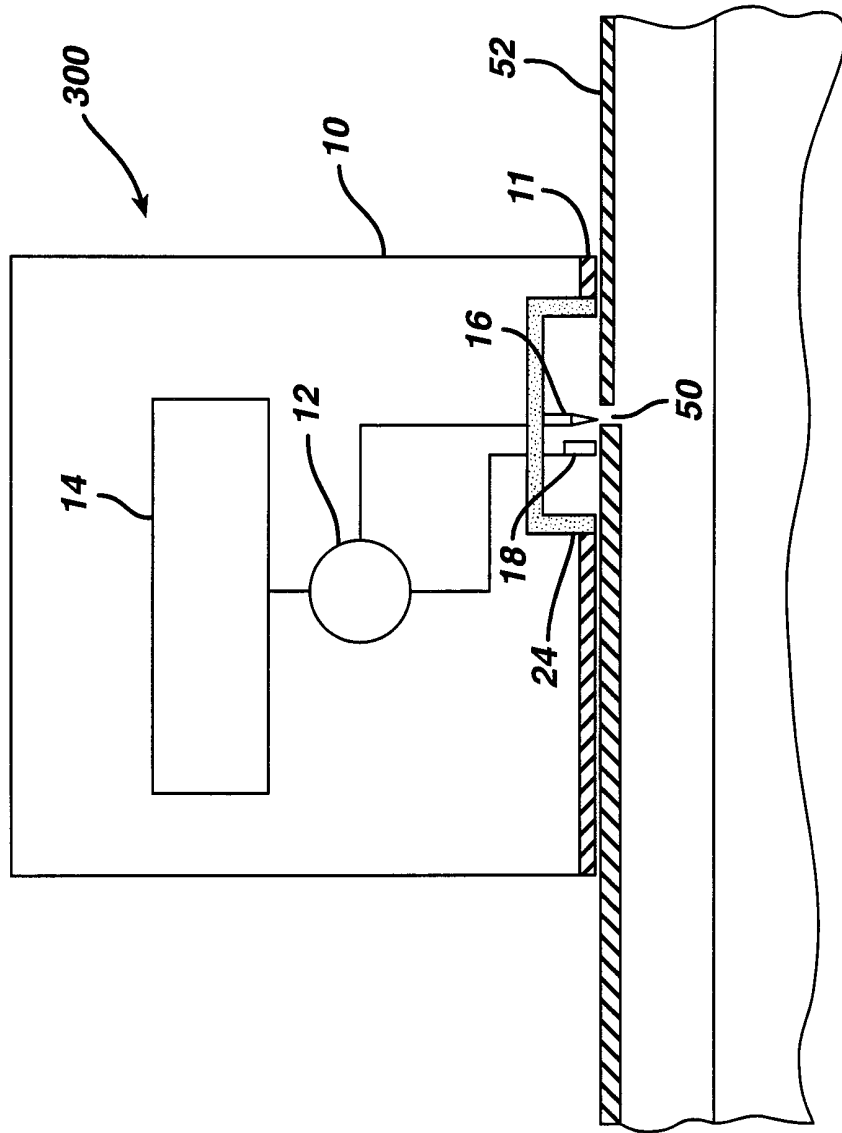

FIG. 3

FIG. 4

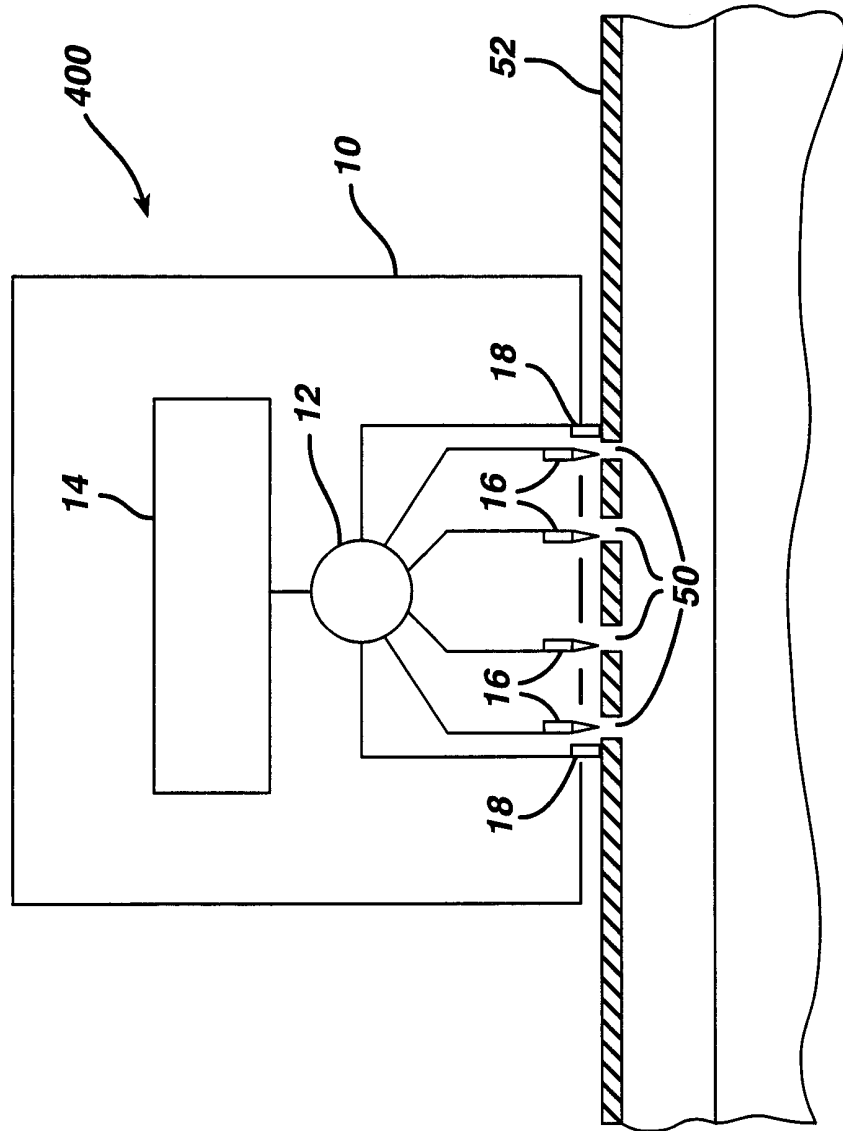

FIG. 5

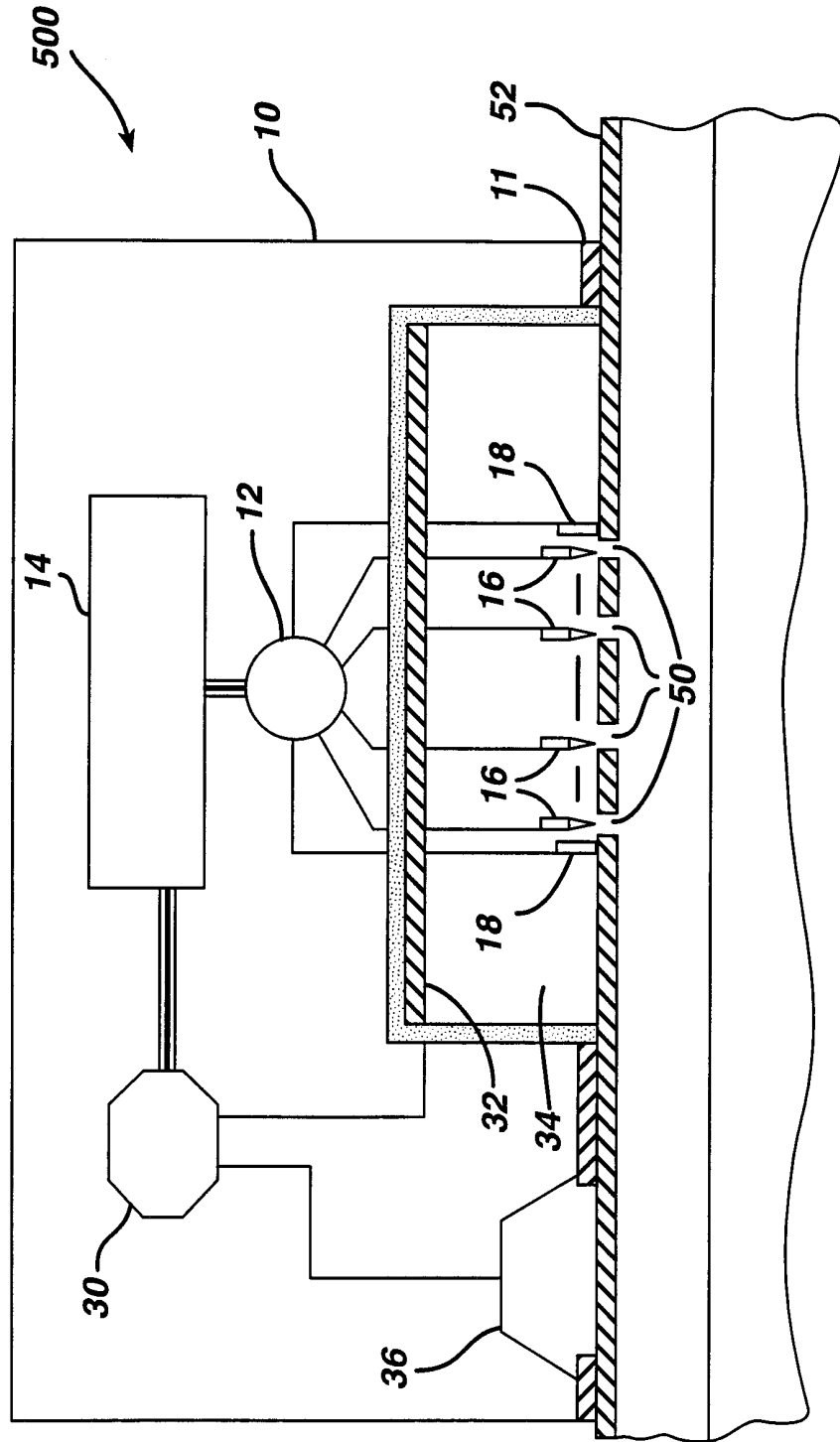
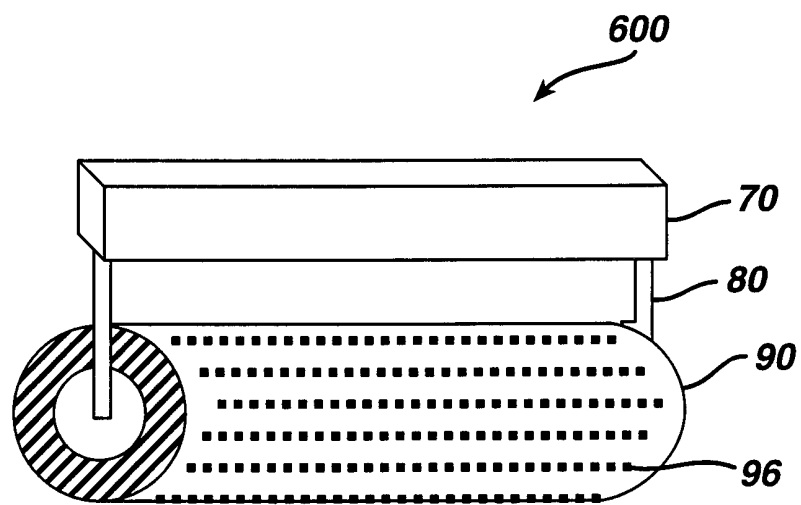

FIG. 6



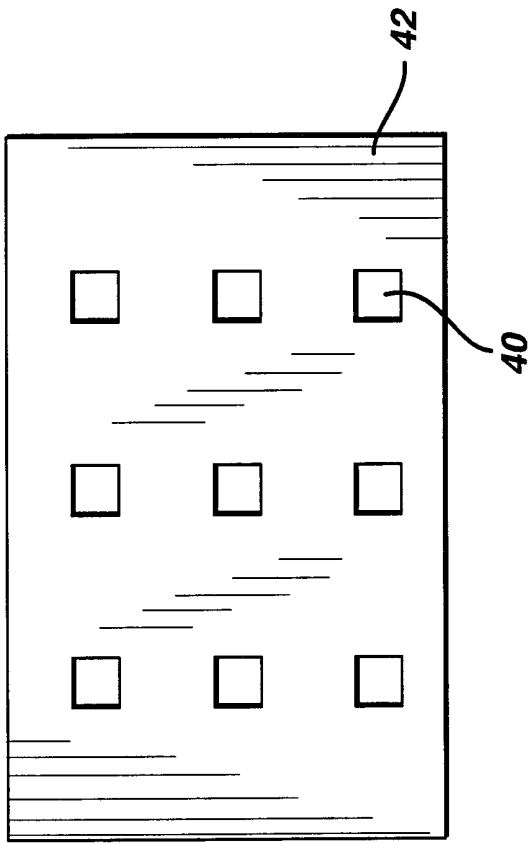

FIG. 7b

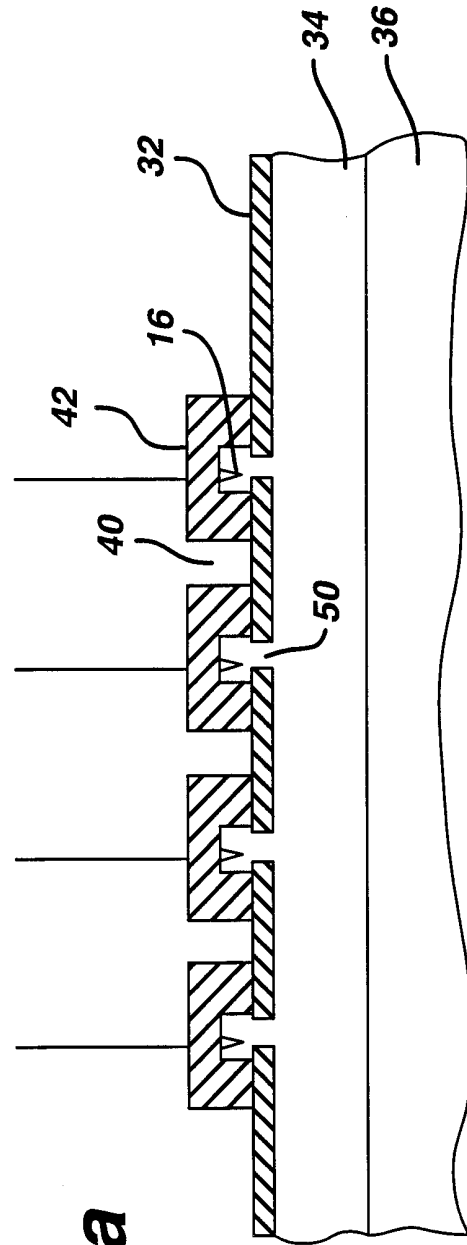
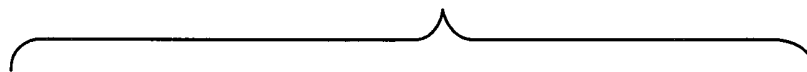

FIG. 7a

FIG. 8



Needle electrode



Wire electrode



Ball electrode



Rod electrode
(protruding flat tip)



Plate electrode
(Indented flat tip)

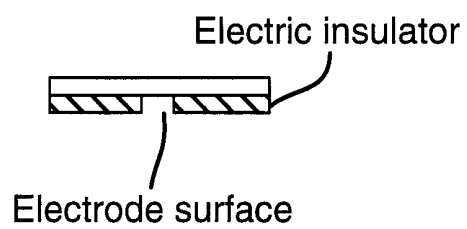

FIG. 9a

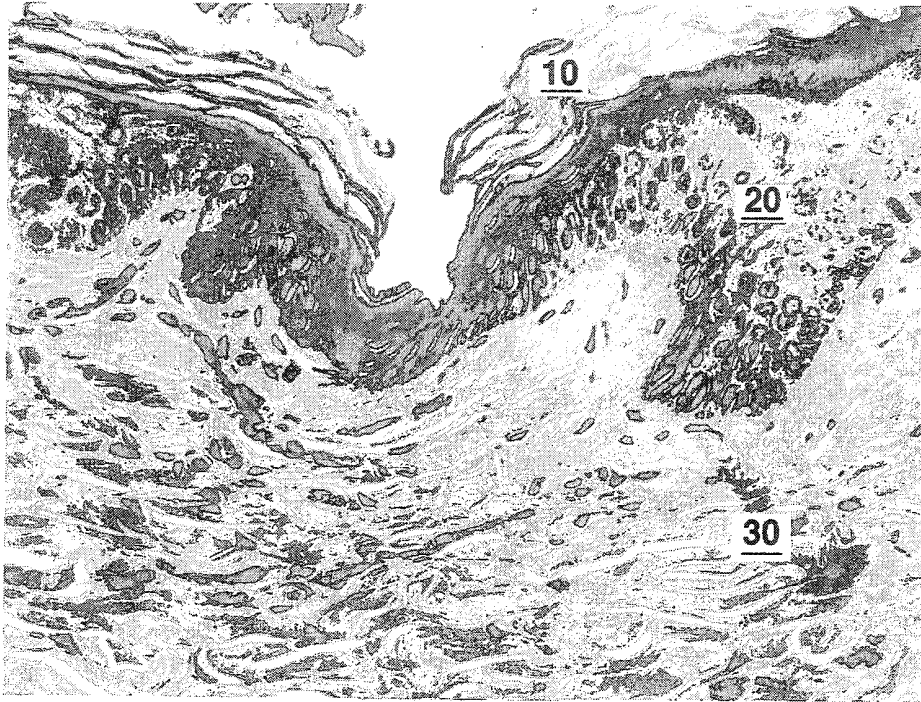
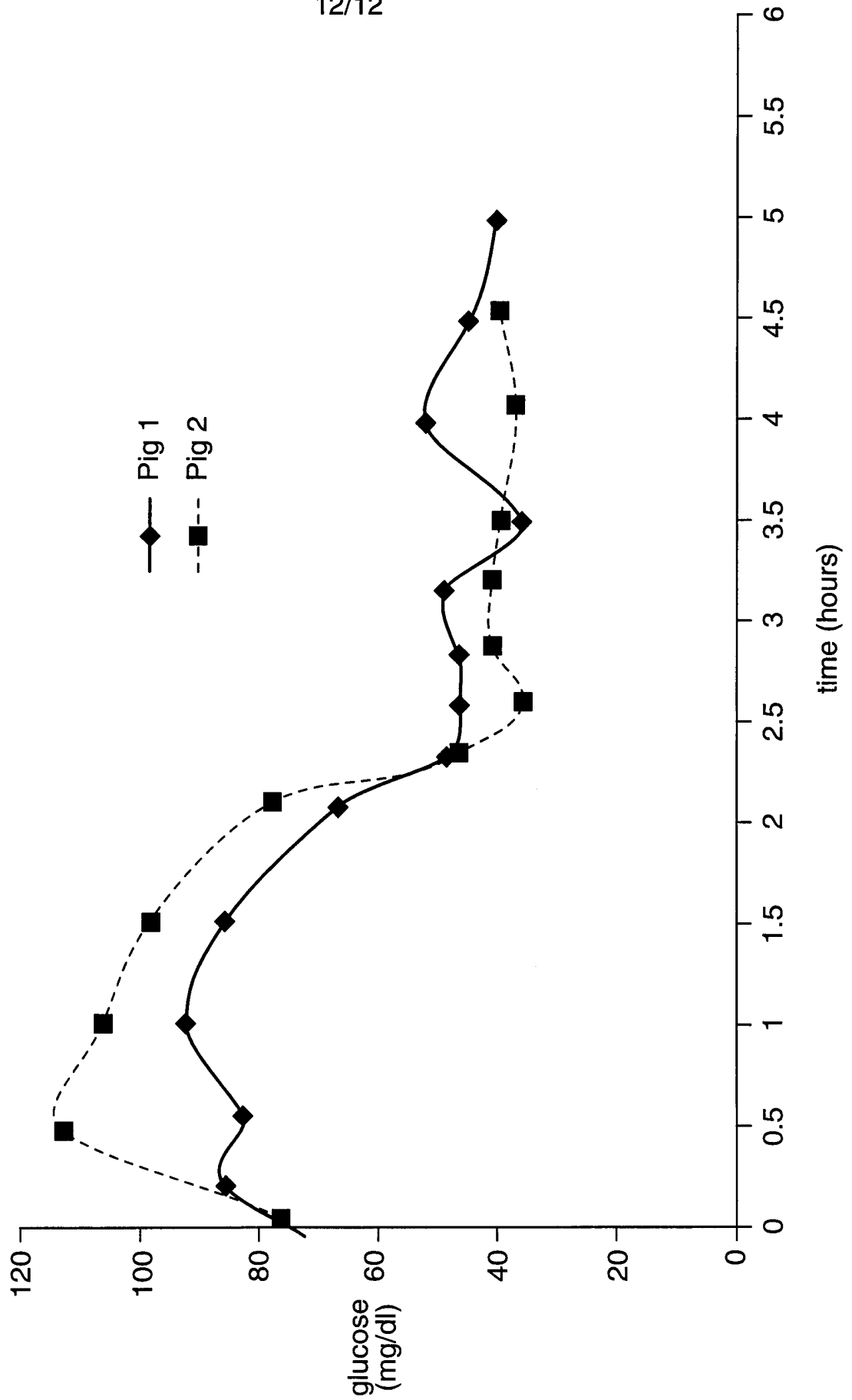

FIG. 9b



12/12

FIG. 10



INTERNATIONAL SEARCH REPORT

International Application No

PCT/US 00/23262

A. CLASSIFICATION OF SUBJECT MATTER
 IPC 7 A61N1/32

According to International Patent Classification (IPC) or to both national classification and IPC

B. FIELDS SEARCHED

Minimum documentation searched (classification system followed by classification symbols)

IPC 7 A61N

Documentation searched other than minimum documentation to the extent that such documents are included in the fields searched

Electronic data base consulted during the international search (name of data base and, where practical, search terms used)

EPO-Internal, WPI Data

C. DOCUMENTS CONSIDERED TO BE RELEVANT

Category *	Citation of document, with indication, where appropriate, of the relevant passages	Relevant to claim No.
X	US 5 885 211 A (EPPSTEIN JONATHAN A ET AL) 23 March 1999 (1999-03-23) cited in the application	20, 26
A	column 19, line 50 - column 20, line 43; figures	21-25, 27
A	WO 97 04832 A (MASSACHUSETTS INST TECHNOLOGY) 13 February 1997 (1997-02-13) page 64, line 15 - line 27; figures	20, 22, 25
A	WO 97 48440 A (ALZA CORP) 24 December 1997 (1997-12-24) cited in the application page 3, line 9 - page 4, line 12; figures	20, 21, 25, 27, 28
A	US 5 386 837 A (STERZER FRED) 7 February 1995 (1995-02-07) column 2, line 16 - line 30; figures	20
	-/--	

Further documents are listed in the continuation of box C.

Patent family members are listed in annex.

* Special categories of cited documents :

- *A* document defining the general state of the art which is not considered to be of particular relevance
- *E* earlier document but published on or after the international filing date
- *L* document which may throw doubts on priority claim(s) or which is cited to establish the publication date of another citation or other special reason (as specified)
- *O* document referring to an oral disclosure, use, exhibition or other means
- *P* document published prior to the international filing date but later than the priority date claimed

- *T* later document published after the international filing date or priority date and not in conflict with the application but cited to understand the principle or theory underlying the invention
- *X* document of particular relevance; the claimed invention cannot be considered novel or cannot be considered to involve an inventive step when the document is taken alone
- *Y* document of particular relevance; the claimed invention cannot be considered to involve an inventive step when the document is combined with one or more other such documents, such combination being obvious to a person skilled in the art.
- *&* document member of the same patent family

Date of the actual completion of the international search

16 November 2000

Date of mailing of the international search report

22/11/2000

Name and mailing address of the ISA

European Patent Office, P.B. 5818 Patentlaan 2
 NL - 2280 HV Rijswijk
 Tel. (+31-70) 340-2040, Tx. 31 651 epo nl,
 Fax: (+31-70) 340-3016

Authorized officer

Rakotondrajaona, C

INTERNATIONAL SEARCH REPORT

International Application No PCT/US 00/23262

C.(Continuation) DOCUMENTS CONSIDERED TO BE RELEVANT		
Category °	Citation of document, with indication, where appropriate, of the relevant passages	Relevant to claim No.
A	WO 98 29134 A (EPPSTEIN JONATHAN A ;ALTEA TECHNOLOGIES INC (US)) 9 July 1998 (1998-07-09) page 10, line 17 -page 11, line 18; figures -----	20
X,P	US 6 104 952 A (TU HOSHENG ET AL) 15 August 2000 (2000-08-15) column 3, line 34 -column 4, line 37; figures -----	20

INTERNATIONAL SEARCH REPORT

information on patent family members

International Application No

PCT/US 00/23262

Patent document cited in search report	Publication date	Patent family member(s)	Publication date
US 5885211 A	23-03-1999	US 5458140 A	17-10-1995
		US 5445611 A	29-08-1995
		AU 707065 B	01-07-1999
		AU 6863196 A	19-03-1997
		BR 9610012 A	21-12-1999
		CA 2199002 A,C	01-03-1997
		CN 1195276 A	07-10-1998
		EP 0858285 A	19-08-1998
		GB 2307414 A,B	28-05-1997
		HK 1009321 A	28-05-1999
		JP 11511360 T	05-10-1999
		NO 980878 A	27-04-1998
		WO 9707734 A	06-03-1997
		US 5722397 A	03-03-1998
US 6018678 A	25-01-2000		
WO 9704832 A	13-02-1997	US 6002961 A	14-12-1999
		US 5814599 A	29-09-1998
		US 5947921 A	07-09-1999
		US 6041253 A	21-03-2000
		AU 725269 B	12-10-2000
		AU 6598796 A	26-02-1997
		CA 2200984 A	13-02-1997
		EP 0781150 A	02-07-1997
		JP 10509632 T	22-09-1998
		US 6018678 A	25-01-2000
WO 9748440 A	24-12-1997	AU 3399197 A	07-01-1998
		AU 3493397 A	07-01-1998
		AU 3572597 A	07-01-1998
		CA 2257217 A	24-12-1997
		EP 0914178 A	12-05-1999
		EP 0917483 A	26-05-1999
		EP 0917484 A	26-05-1999
		WO 9748441 A	24-12-1997
		WO 9748442 A	24-12-1997
US 5386837 A	07-02-1995	NONE	
WO 9829134 A	09-07-1998	AU 5623298 A	31-07-1998
		EP 0952850 A	03-11-1999
		AU 3880697 A	21-01-1998
		EP 0921840 A	16-06-1999
US 6104952 A	15-08-2000	US 5968005 A	19-10-1999