

(21) Application No: 2202778.3

(22) Date of Filing: 01.07.2016

Date Lodged: 01.03.2022

(30) Priority Data:

(31) 62187470	(32) 01.07.2015	(33) US
(31) 14859035	(32) 18.09.2015	(33) US
(31) US2015056394	(32) 20.10.2015	(33) WO
(31) 14920819	(32) 22.10.2015	(33) US
(31) 14925837	(32) 28.10.2015	(33) US
(31) 15017424	(32) 05.02.2016	(33) US
(31) 15047522	(32) 18.02.2016	(33) US
(31) 15052876	(32) 25.02.2016	(33) US
(31) 15086034	(32) 30.03.2016	(33) US

(62) Divided from Application No 1805236.5 under section 15(9) of the Patents Act 1977

(71) Applicant(s):

**Unanimous A.I. INC**  
**(Incorporated in USA - California)**  
**2443 Fillmore Street #116, San Francisco, CA, 94115,**  
**United States of America**

(72) Inventor(s):

**Louis B Rosenberg**

(74) Agent and/or Address for Service:

**Hoffmann Eitle**  
**Harmsworth House, 13-15 Bouverie Street, London,**  
**EC4Y 8DP, United Kingdom**

(51) INT CL:  
**G06F 3/048** (2013.01)

(56) Documents Cited:

**EP 3210386 A**                      **EP 3123442 A**  
**US 20130019205 A**                **US 20030079218 A**

(58) Field of Search:

INT CL **G06F**  
 Other: **WPI, EPODOC**

(54) Title of the Invention: **Methods and systems for enabling a credit economy in a real-time collaborative intelligence**

Abstract Title: **Real-time collaborative group based question and answer system**

(57) Systems 200 and methods for enabling a group of individuals, to collaboratively answer questions or otherwise express a collaborative will/intent in real-time are disclosed. The collaboration system uses a set of computing devices 202, 204, 206, each being used by an individual user. The computing devices enable its user to contribute to the emerging real-time group-wise intent, via the user repeatedly sending 208 an updated input or intent, to a collaboration server 142 in response to the receiving interim group-wise intent, from the server. Also disclosed are a variety of methods for implementing a credit economy for the collaboration system. A credit amount is associated with each user. Credits are awarded to users for certain events, such as successful completion of a collaborative session, and decremented for other events, such as for asking a question to be answered by the group.

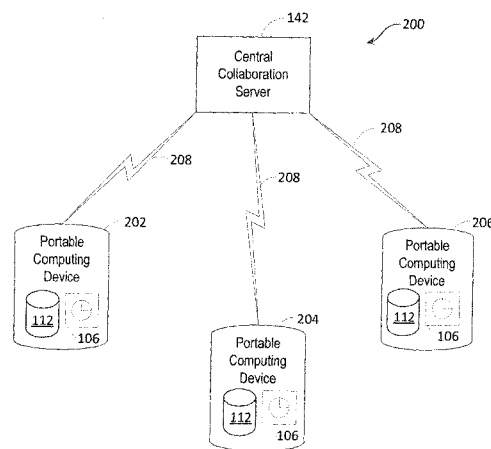

FIG. 2

07 03 22

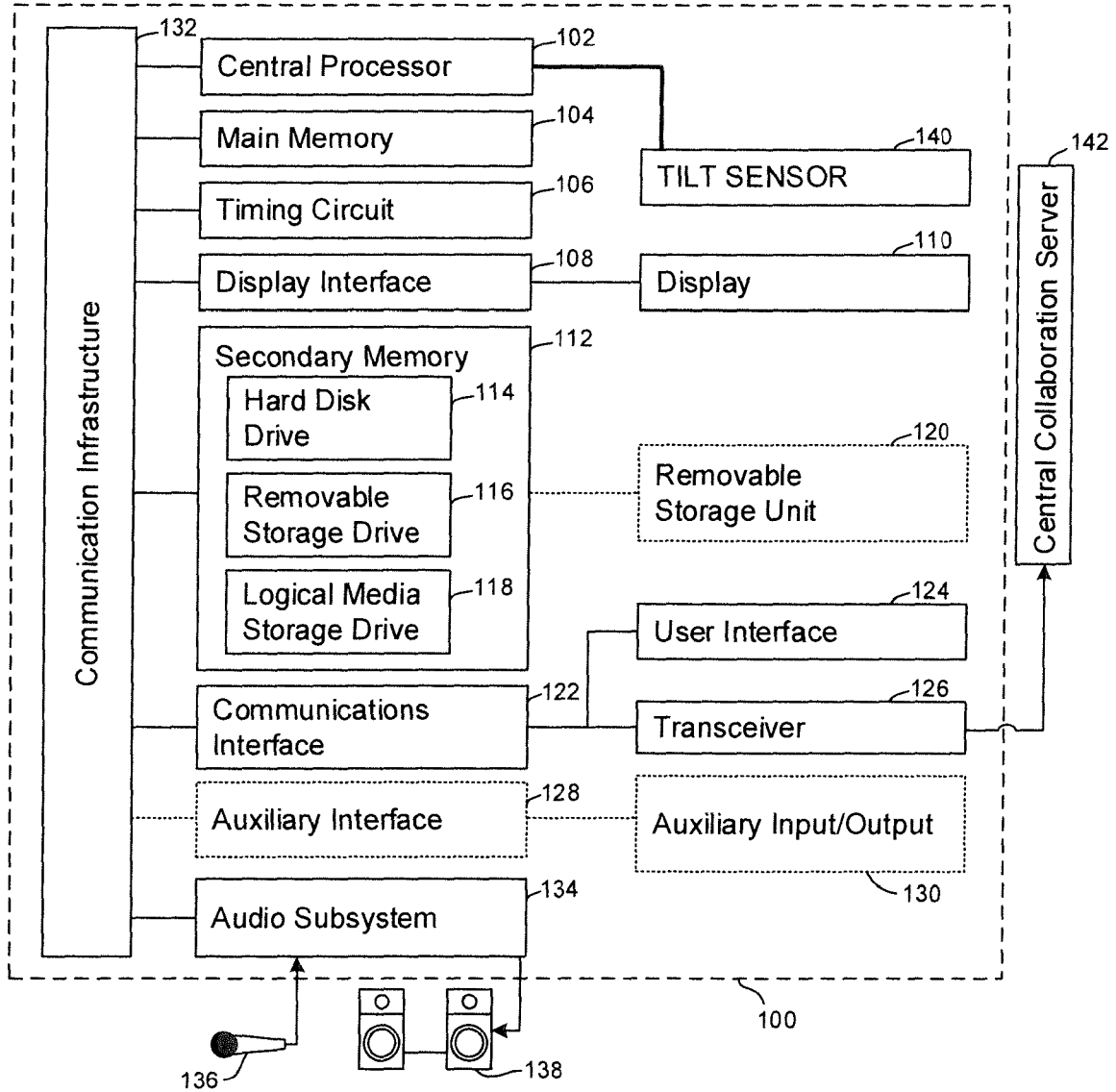

FIG. 1

07 03 22

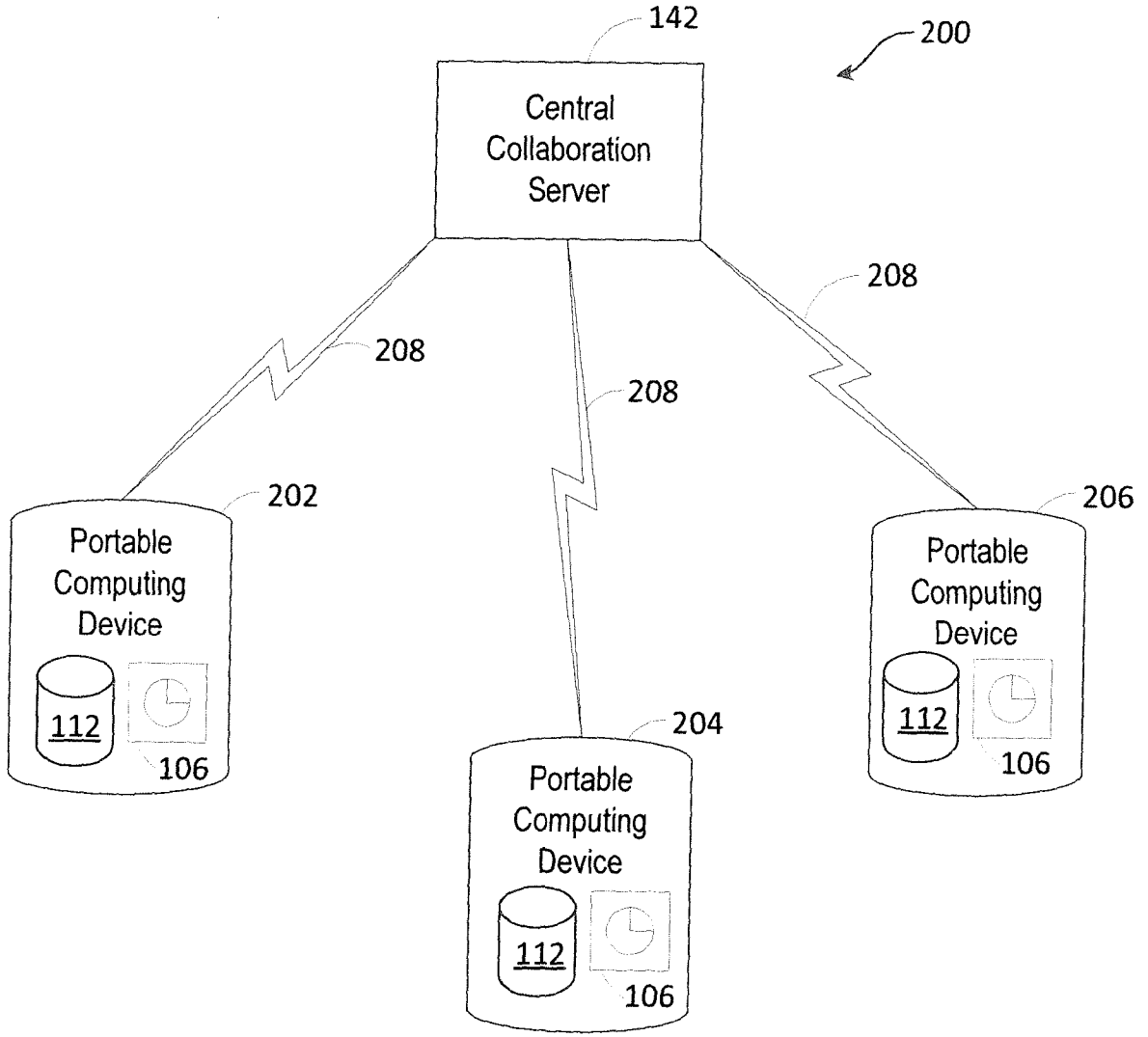

FIG. 2

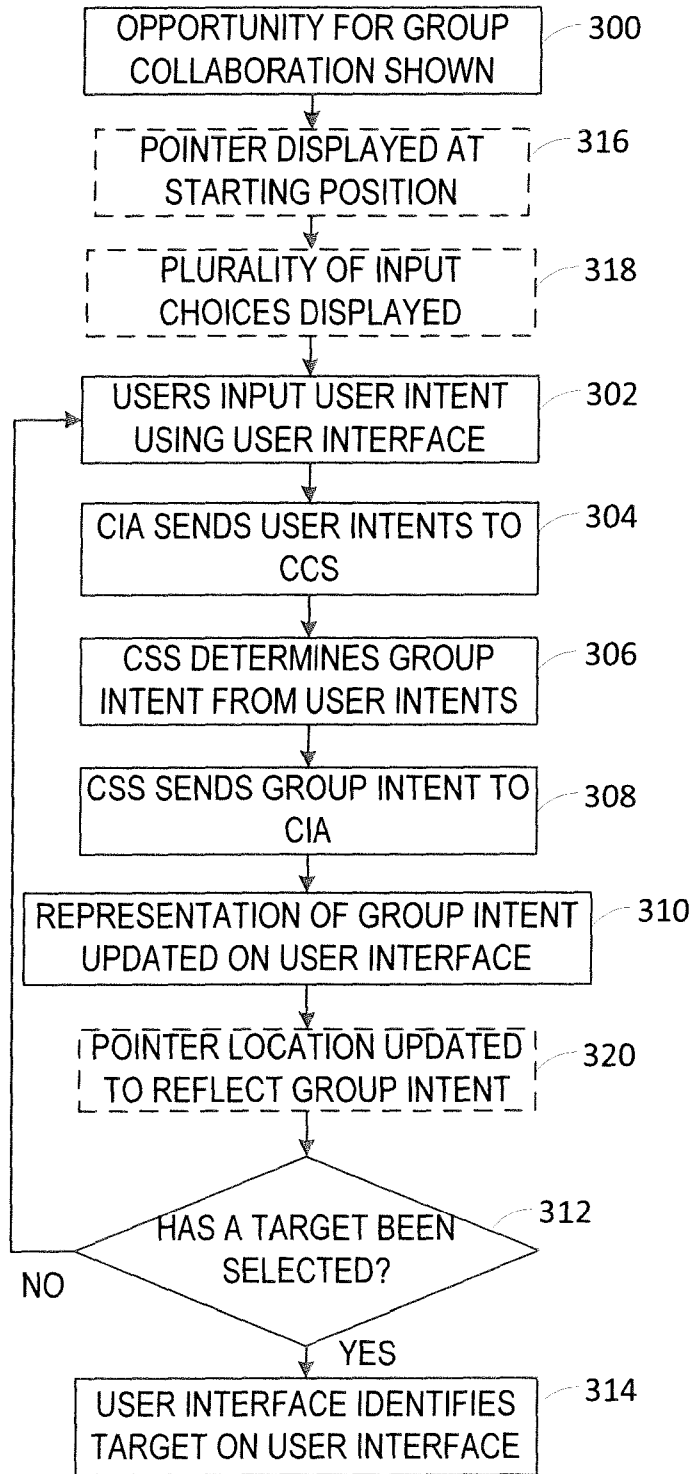

FIG. 3

07 03 22

4/12

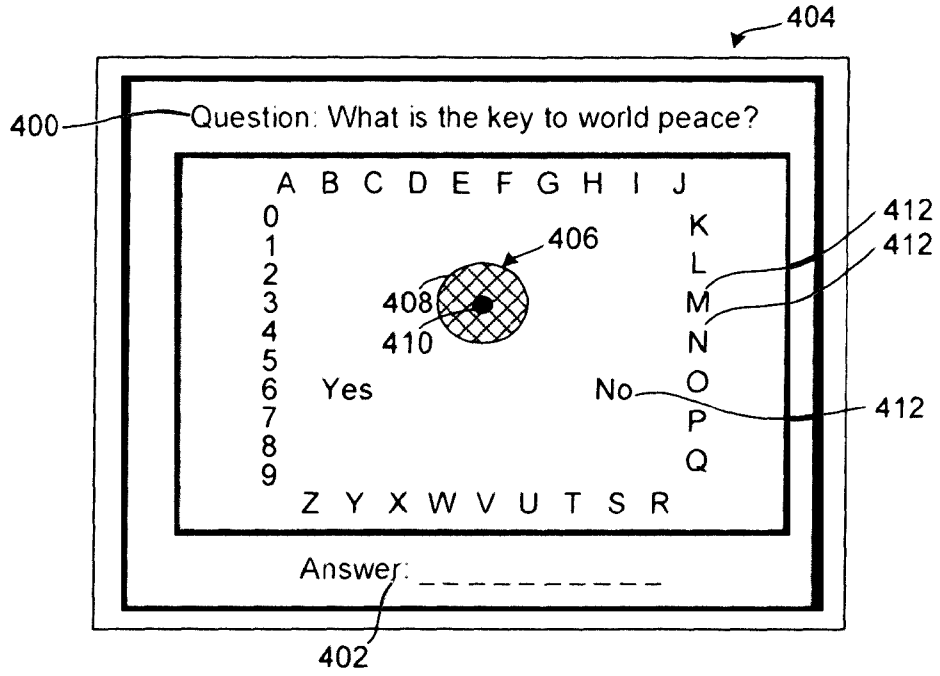
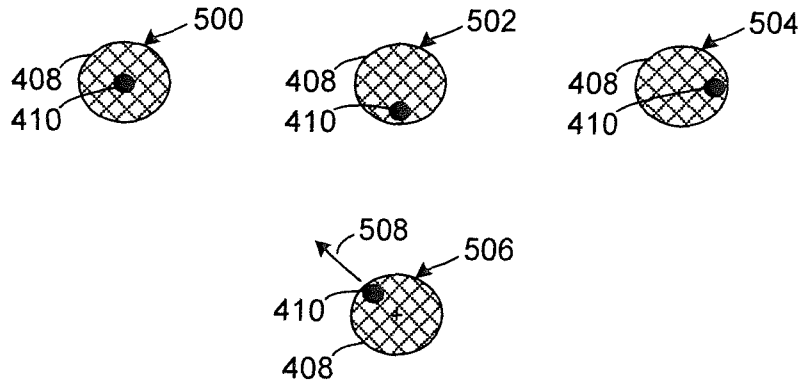
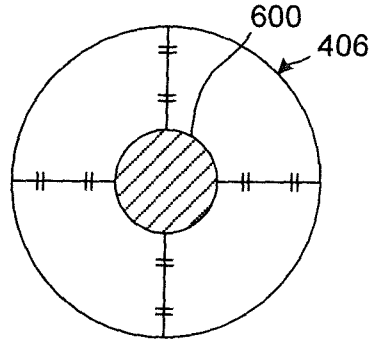

FIG. 4

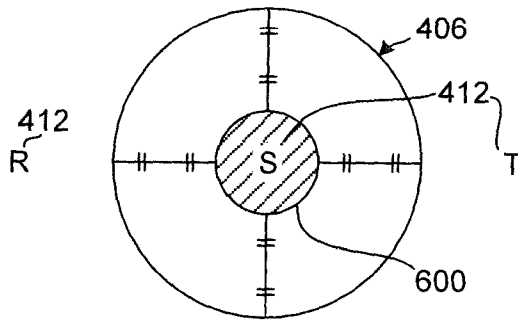

**FIG. 5**

6/12



**FIG. 6**



**FIG. 7**

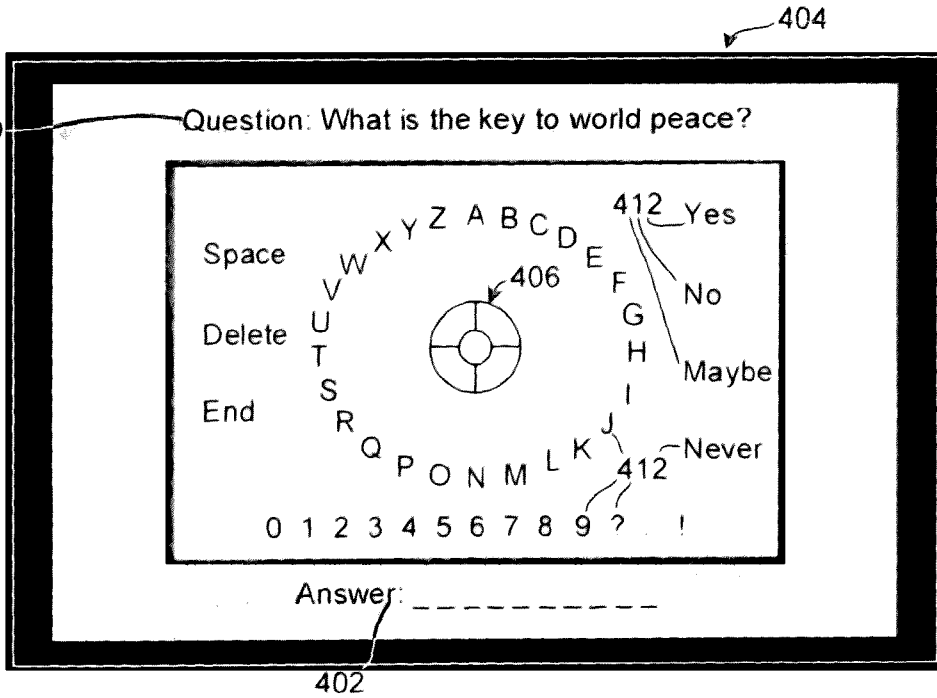

FIG. 8

07 03 22



07 03 22

8/12

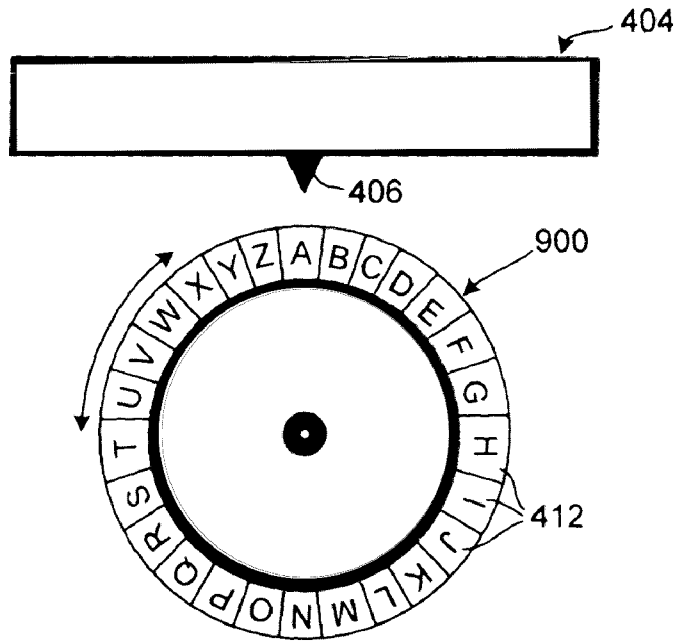

FIG. 9

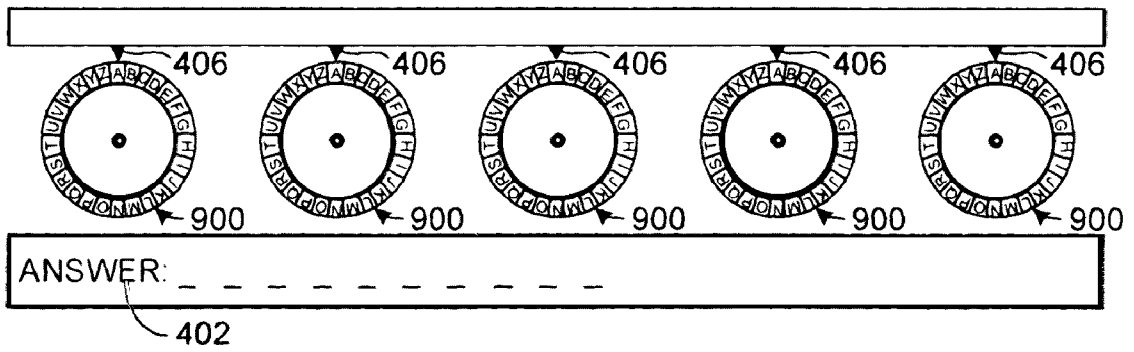
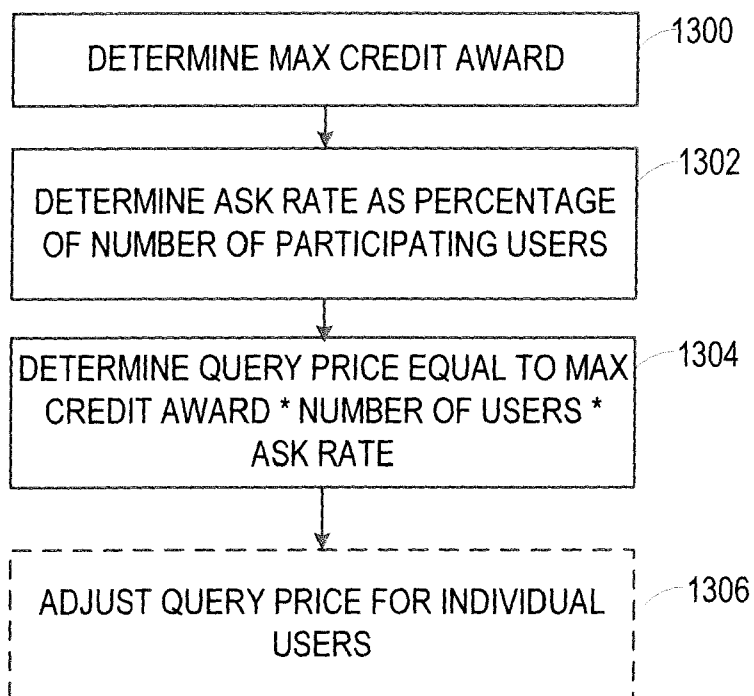

FIG. 10



07 03 22



**FIG. 13**

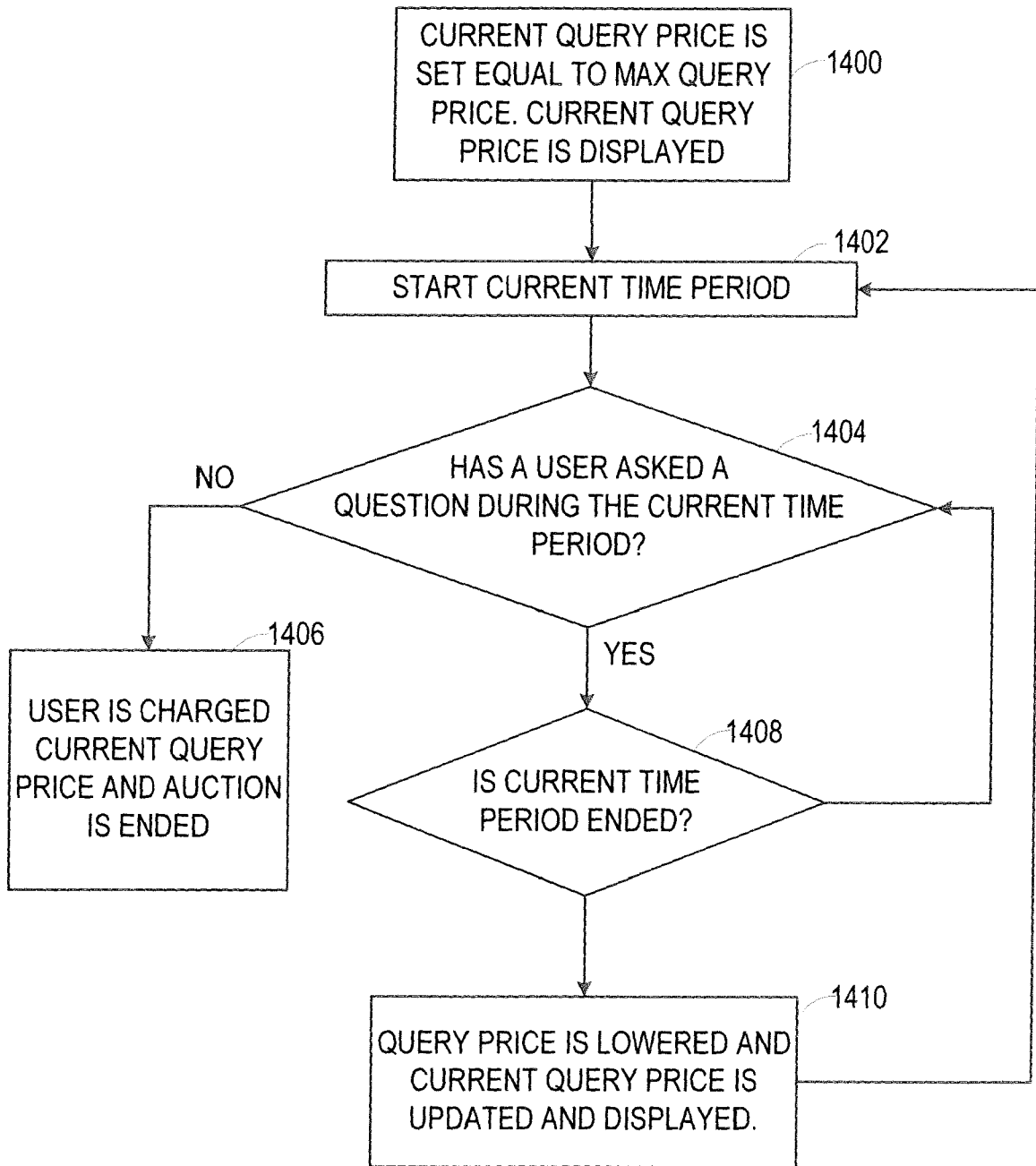

FIG. 14

07 03 22

07 03 22

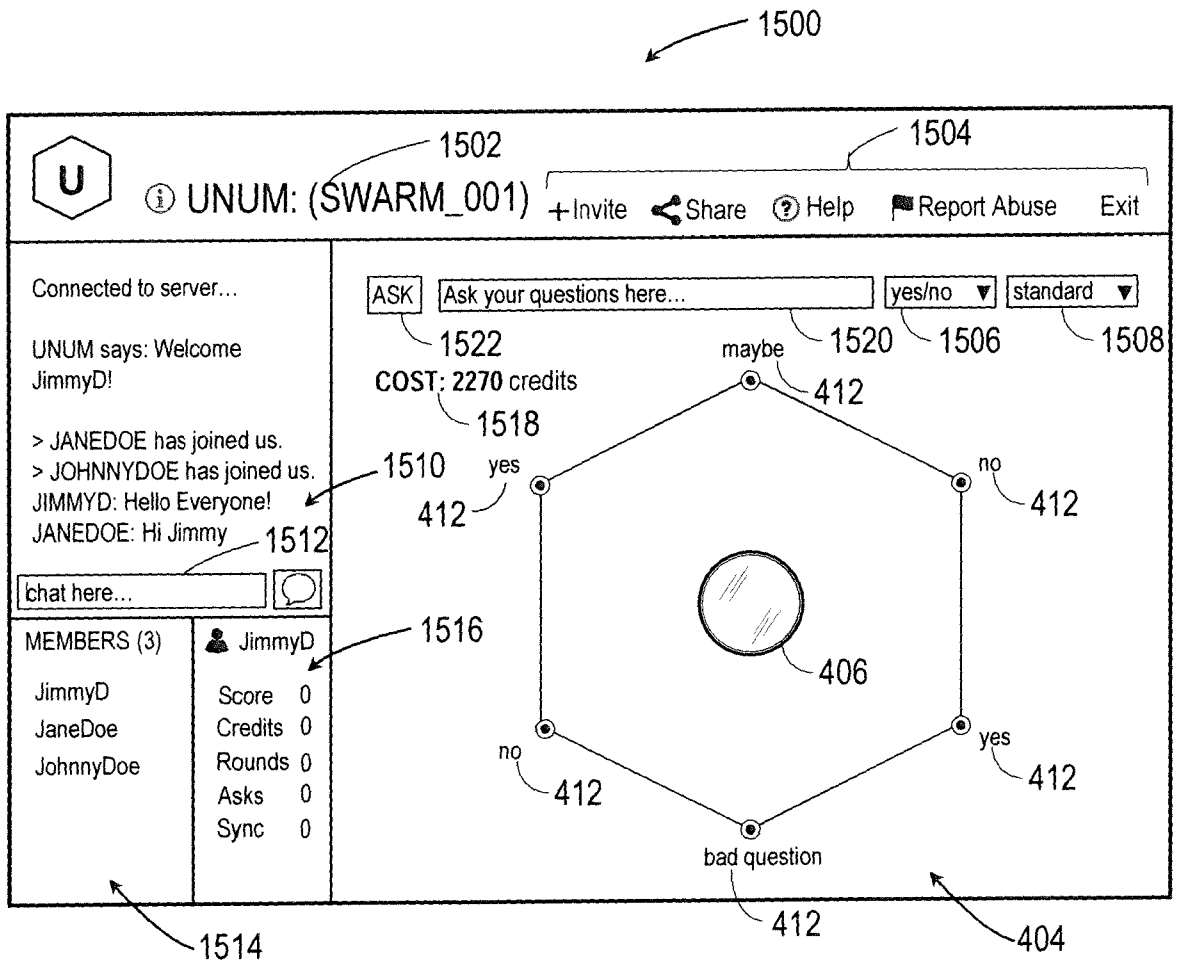

FIG. 15

**METHODS AND SYSTEMS FOR ENABLING A CREDIT ECONOMY IN A  
REAL-TIME COLLABORATIVE INTELLIGENCE**

5

This application claims the benefit of U.S. Provisional Application No. 62/187,470 entitled METHODS AND SYSTEMS FOR ENABLING A CREDIT ECONOMY IN A REAL-TIME SYNCHRONOUS COLLABORATIVE SYSTEM, filed July 1, 2015, which is incorporated in its entirety herein by reference.

This application is a continuation-in-part of U.S. Application No. 14/668,970 entitled METHODS AND SYSTEMS FOR REAL-TIME CLOSED-LOOP COLLABORATIVE INTELLIGENCE, filed March 25, 2015, which in turn claims the benefit of U.S. Provisional Application 61/970,885 entitled METHOD AND SYSTEM FOR ENABLING A GROUPWISE COLLABORATIVE CONSCIOUSNESS, filed March 26, 2014, both of which are incorporated in their entirety herein by reference.

This application is a continuation-in-part of U.S. Application No. 14/708,038 entitled MULTI-GROUP METHODS AND SYSTEMS FOR REAL-TIME MULTI-TIER COLLABORATIVE INTELLIGENCE, filed May 8, 2015, which in turn claims the benefit of U.S. Provisional Application 61/991,505 entitled METHODS AND SYSTEM FOR MULTI-TIER COLLABORATIVE INTELLIGENCE, filed May 10, 2014, both of which are incorporated in their entirety herein by reference.

30

This application is a continuation-in-part of U.S. Application No. 14/738,768 entitled INTUITIVE INTERFACES FOR REAL-TIME COLLABORATIVE INTELLIGENCE, filed June 12, 2015, which in turn claims the benefit of U.S. Provisional Application 62/012,403 entitled INTUITIVE INTERFACE FOR REAL-TIME COLLABORATIVE CONTROL, filed June 15, 2014, both of which are incorporated in their entirety herein by reference.

This application is a continuation-in-part of U.S. Application No. 14/859,035 entitled SYSTEMS AND METHODS FOR ASSESSMENT AND OPTIMIZATION OF REAL-TIME COLLABORATIVE INTELLIGENCE SYSTEMS, filed September 18, 2015 which in turn claims the benefit of U.S. Provisional Application No. 62/066,718 entitled SYSTEM AND METHOD FOR MODERATING AND OPTIMIZING REAL-TIME SWARM INTELLIGENCES, filed October 21, 2014, both of which are incorporated in their entirety herein by reference.

This application is a continuation-in-part of U.S. Application No. 14/920,819 entitled SUGGESTION AND BACKGROUND MODES FOR REAL-TIME COLLABORATIVE INTELLIGENCE SYSTEMS, filed October 22, 2015 which in turn claims the benefit of U.S. Provisional Application No. 62/067,505 entitled SYSTEM AND METHODS FOR MODERATING REAL-TIME COLLABORATIVE DECISIONS OVER A DISTRIBUTED NETWORKS, filed October 23, 2014, both of which are incorporated in their entirety herein by reference.

This application is a continuation-in-part of U.S. Application No. 14/925,837 entitled MULTI-PHASE MULTI-GROUP SELECTION METHODS FOR REAL-TIME COLLABORATIVE INTELLIGENCE SYSTEMS, filed October 28, 2015 which in  
5 turn claims the benefit of U.S. Provisional Application No. 62/069,360 entitled SYSTEMS AND METHODS FOR ENABLING AND MODERATING A MASSIVELY-PARALLEL REAL-TIME SYNCHRONOUS COLLABORATIVE SUPER-INTELLIGENCE, filed October 28, 2014, both of which are incorporated in their entirety herein  
10 by reference.

This application is a continuation-in-part of U.S. Application No. 15/017,424 entitled ITERATIVE SUGGESTION MODES FOR REAL-TIME COLLABORATIVE INTELLIGENCE SYSTEMS,  
15 filed February 5, 2016 which in turn claims the benefit of U.S. Provisional Application No. 62/113,393 entitled SYSTEMS AND METHODS FOR ENABLING SYNCHRONOUS COLLABORATIVE CREATIVITY AND DECISION MAKING, filed February 7, 2015, both of which are incorporated in their  
20 entirety herein by reference.

This application is a continuation-in-part of U.S. Application No. 15/047,522 entitled SYSTEMS AND METHODS FOR COLLABORATIVE SYNCHRONOUS IMAGE SELECTION, filed  
25 February 18, 2016 which in turn claims the benefit of U.S. Provisional Application No. 62/117,808 entitled SYSTEM AND METHODS FOR COLLABORATIVE SYNCHRONOUS IMAGE SELECTION, filed February 18, 2015, both of which are incorporated in their entirety herein by reference.

30



This application is a continuation-in-part of U.S. Application No. 15/052,876 entitled DYNAMIC SYSTEMS FOR OPTIMIZATION OF REAL-TIME COLLABORATIVE INTELLIGENCE, filed February 25, 2016 which in turn claims the benefit of U.S. Provisional Application No. 62/120,618 entitled APPLICATION OF DYNAMIC RESTORING FORCES TO OPTIMIZE GROUP INTELLIGENCE IN REAL-TIME SOCIAL SWARMS, filed February 25, 2015, both of which are incorporated in their entirety herein by reference.

10

This application is a continuation-in-part of U.S. Application No. 15/086,034 entitled SYSTEM AND METHOD FOR MODERATING REAL-TIME CLOSED-LOOP COLLABORATIVE DECISIONS ON MOBILE DEVICES, filed March 30, 2016 which in turn claims the benefit of U.S. Provisional Application No. 62/140,032 entitled SYSTEM AND METHOD FOR MODERATING A REAL-TIME CLOSED-LOOP COLLABORATIVE APPROVAL FROM A GROUP OF MOBILE USERS filed March 30, 2015, both of which are incorporated in their entirety herein by reference.

20

This application is a continuation-in-part of International Application No. PCT/US15/22594, filed March 25, 2015.

25 This application is a continuation-in-part of International Application No. PCT/US15/35694, filed June 12, 2015.

This application is a continuation-in-part of International Application No. PCT/US15/56394, filed October 20, 2015.

5

## BACKGROUND OF THE INVENTION

### 1. Field of the Invention

The present invention relates generally to systems and methods for group collaboration, and more specifically to systems and methods for synchronous closed-loop, dynamic group intelligence, and even more specifically to credit economies for synchronous closed-loop, dynamic group intelligence.

### 2. Discussion of the Related Art

Portable computing devices, such as cell phones, personal digital assistants, and portable media players have become popular personal devices due to their highly portable nature, their ability to provide accessibility to a large library of stored media files, their interconnectivity with existing computer networks, and their ability to pass information to other portable computing devices and/or to centralized servers through phone networks, wireless networks and/or through local spontaneous networks such as Bluetooth® networks. Many of these devices also provide the ability to store and display media, such as songs, videos, podcasts, ebooks, maps, and other related content and/or programming. Many of these devices are also used as navigation tools, including GPS functionality. Many of these devices are also used as personal communication devices, enabling

phone, text, picture, and video communication with other similar portable devices. Many of these devices include touch screens, tilt interfaces, voice recognition, and other modern user input modes. As a result, the general social trend within industrial societies is that every person does now or soon will maintain at least one such multi-purpose electronic device upon their person at most times, especially when out and about.

While such devices allow accessing information and person to person communication, they do not provide any unique tools and infrastructure that specifically enable groups of electronically networked individuals to have a real-time group-wise experience that evokes the group's collaborative intelligence (also referred to as Collective Intelligence or Swarm Intelligence). Hence, there is a substantial need to provide tools and methods by which groups of individuals, each having a computing device local to their person, to more easily contribute their personal will/intent to a synchronous collaborative intelligence, allowing the group to collectively answer questions or otherwise express their group-wise will in real-time. Furthermore, there is a need to provide tools and methods that enable groups of users to be informed of the group-wise will that is emerging in real-time by answering questions as a synchronous closed-loop system. Furthermore, there is a need to provide tools and methods that enable groups of users to take turns asking questions to the synchronous closed-loop system that answers as a Collective Intelligence. The present invention, as described herein, addresses these and other deficiencies present in the art.

## SUMMARY OF THE INVENTION

Several embodiments of the invention advantageously address the needs above as well as other needs by providing a collaborative system for determining a collaborative intelligence system for determining a group result in real-time from a group of users presented with a group question, comprising: a plurality of computing devices, at least one user associated with each computing device, each computing device comprising a communications infrastructure coupled to each of a processor, a memory, a timing circuit, a display interface coupled to a display and configured to receive input from at least one user; a collaborative approval application stored on each memory and configured to run on each processor to: convey to the user, using the display interface, the group question, receive, repeatedly in real-time, user input; send, repeatedly in real-time, a representation of the user input to a collaboration server; receive, repeatedly in real-time, the group result from the collaboration server, the group result based at least in part on the plurality of representations of user inputs; and present, repeatedly in real-time, a graphical indication of the group result to the user using the display interface; the collaboration server in networked communication with the plurality of computing devices, the collaboration server including a server processor and a server memory, the server processor configured to run a collaboration application stored on the server memory, the collaboration application configured to perform the steps of: assign and store a unique identity for each user; and store a credit amount for each user, wherein the credit amount may be changed based at least in part

upon that user's participation in at least one of asking  
the group question and providing user input in response  
to the group question; send the group question to the  
plurality of computing devices, receive, repeatedly in  
5 real-time, the representation of the user input from each  
of the plurality of computing devices; responsively  
determine, repeatedly in real-time, the group result from  
the user input; and send, repeatedly in real-time, the  
group result to the plurality of computing devices,  
10 whereby a closed-loop system is formed between the  
collaboration server and each collaborative intent  
applications; determine a final group result; and send  
the final group result to the plurality of computing  
devices.

15 In another embodiment, the invention can be  
characterized as a method for enabling a credit economy  
for a collaborative intelligence system for determining a  
group result in real-time from a group of users,  
including a collaboration server including a server  
20 processor and a server memory, the server processor  
configured to run a collaboration application stored on  
the server memory, the collaborative intelligence system  
further including a plurality of computing devices, at  
least one user associated with each computing device,  
25 each user associated with a credit value stored by the  
collaboration server, each computing device comprising a  
communications infrastructure coupled to each of a device  
processor, a device memory, a timing circuit, a display  
interface coupled to a display and configured to receive  
30 input from at least one user, and a collaborative  
approval application stored on each device memory and  
configured to run on each device processor, wherein the

collaboration server is in networked communication with the plurality of computing devices, the method comprising the steps of: determining, by the collaboration server, of a query price, said query price based at least in part  
5 upon a number of users in the group of users; receiving, by the collaboration server, of a group question from a first user; enabling, by the collaboration server in response to receiving of the group question, the plurality of users to collaboratively answer the group  
10 question by collaboratively generating a group result; decrementing the query price from a credit amount associated with the first user based upon a determination that the first user asked the group question that was collaboratively answered by a participating portion of  
15 the group of users; determining, by the collaboration server, a credit award value, the credit award value based at least in part upon the number of users in the group of users; and incrementing, by the collaboration server, of the credit amount associated with each of the  
20 participating portion of the group of users, the incrementing of the credit amount based at least in part upon the credit award value associated with the group question.

In yet another embodiment, the invention may be  
25 characterized as a countdown auction method for determining a query price for a collaborative intelligence system for determining a group result in real-time from a group of users, including a collaboration server including a server processor and a  
30 server memory, the server processor configured to run a collaboration application stored on the server memory, the collaborative intelligence system further including a

plurality of computing devices, at least one user associated with each computing device, each user associated with a credit value stored by the collaboration server, each computing device comprising a communications infrastructure coupled to each of a device processor, a device memory, a timing circuit, a display interface coupled to a display and configured to receive input from at least one user, and a collaborative approval application stored on each device memory and configured to run on each device processor, wherein the collaboration server is in networked communication with the plurality of computing devices, the method comprising the steps of: setting an initial query price on each of the plurality of computing devices, the setting coordinated by the collaboration application; displaying, by each computing device, of a current query price equal to an initial query price on the display; repeatedly determining, by the collaboration server, whether one user has input a question via one of the plurality of computing devices; during a time period when no user has input the question, repeatedly decrementing the current query price as displayed by each of the plurality of computing devices, the current query price representing a current cost of asking a question for each user associated with each computing device, thereby enabling a real-time credit auction among the plurality of users; and upon determining that a first user of the group of users has input the question, decrementing a credit amount associated with the first user by the current query price displayed to the first user.

### BRIEF DESCRIPTION OF THE DRAWINGS

The above and other aspects, features and advantages of several embodiments of the present invention will be more apparent from the following more particular  
5 description thereof, presented in conjunction with the following drawings.

FIG. 1 is a schematic diagram of a portable computing device in accordance with one embodiment of the present invention.

10 FIG. 2 is a schematic diagram of the collaborative system in accordance with another embodiment of the present invention.

FIG. 3 is a flowchart diagram of a group collaboration process in accordance with another  
15 embodiment of the invention.

FIG. 4 is a user interface display in accordance with an embodiment of the present invention.

FIG. 5 is a diagram of various embodiments of pointer input in accordance the present invention.

20 FIG. 6 is a diagram of a pointer in accordance with one embodiment of the present invention.

FIG. 7 is a diagram of the pointer in accordance with another embodiment of the present invention.

FIG. 8 is a target board in accordance with another  
25 embodiment of the present invention.

FIG. 9 is the target board in accordance with another embodiment of the present invention.

FIG. 10 is the target board in accordance with yet another embodiment of the present invention.



FIG. 11 is the target board in accordance with yet another embodiment of the present invention.

FIG. 12 is the target board in accordance with yet another embodiment of the present invention.

5 FIG. 13 is a flowchart of a method for determining a query price in one embodiment of the present invention.

FIG. 14 is a flowchart for a countdown auction method in one embodiment of the present invention.

10 FIG. 15 is an exemplary user interface screen in accordance with the countdown auction embodiment of the present invention.

Corresponding reference characters indicate corresponding components throughout the several views of the drawings. Skilled artisans will appreciate that  
15 elements in the figures are illustrated for simplicity and clarity and have not necessarily been drawn to scale. For example, the dimensions of some of the elements in the figures may be exaggerated relative to other elements to help to improve understanding of various embodiments  
20 of the present invention. Also, common but well-understood elements that are useful or necessary in a commercially feasible embodiment are often not depicted in order to facilitate a less obstructed view of these various embodiments of the present invention.

25

#### **DETAILED DESCRIPTION**

The following description is not to be taken in a limiting sense, but is made merely for the purpose of describing the general principles of exemplary

embodiments. The scope of the invention should be determined with reference to the claims.

Reference throughout this specification to "one embodiment," "an embodiment," or similar language means  
5 that a particular feature, structure, or characteristic described in connection with the embodiment is included in at least one embodiment of the present invention. Thus, appearances of the phrases "in one embodiment," "in an embodiment," and similar language throughout this  
10 specification may, but do not necessarily, all refer to the same embodiment.

Furthermore, the described features, structures, or characteristics of the invention may be combined in any suitable manner in one or more embodiments. In the  
15 following description, numerous specific details are provided, such as examples of programming, software modules, user selections, network transactions, database queries, database structures, hardware modules, hardware circuits, hardware chips, etc., to provide a thorough  
20 understanding of embodiments of the invention. One skilled in the relevant art will recognize, however, that the invention can be practiced without one or more of the specific details, or with other methods, components, materials, and so forth. In other instances, well-known  
25 structures, materials, or operations are not shown or described in detail to avoid obscuring aspects of the invention.

As referred to in this specification, "media items" refers to video, audio, streaming and any combination  
30 thereof. In addition, the audio subsystem is envisioned to optionally include features such as graphic

equalization, volume, balance, fading, base and treble controls, surround sound emulation, and noise reduction. One skilled in the relevant art will appreciate that the above cited list of file formats is not intended to be  
5 all inclusive.

As described herein, the massive connectivity provided by the Internet is used to create a real-time closed-loop collaborative consciousness (or emergent group-wise intelligence) by collecting real-time input  
10 from large numbers of people through a novel user interface and processing the collected input from that large number of users into a singular intent that can answer questions or otherwise take actions or convey will in real-time. The methods use intervening software and  
15 hardware to moderate the process, closing the loop around the disparate input from each of the many individual participants and the singular output of the group. In a preferred embodiment, each individual user ("participant") engages the user interface on a portable  
20 computing device, conveying his or her individual real-time will in response to a prompt such as a textually displayed (or audibly displayed) question as well as in response to real-time feedback provided to the user of the group's emerging real-time intent. This closes the  
25 loop around each user, for he is conveying individual intent while also reacting to the group's emerging intent. Thus each user must be able to see not only the prompt that begins a session, but the real-time group intent as it is forming. For example, if the intent is  
30 being conveyed as words, the user will see those words form, letter by letter. If the intent is being conveyed as a direction, the user sees the direction form, degree

by degree. If the intent is being conveyed as a choice among objects, the user sees a pointer 406 get closer and closer to a particular chosen object. Thus, the user is seeing the group's will emerge before his eyes, reacting to that will in real-time, and thus contributing to it.  
5 This closes the loop, not just around one user, but around all users who have a similar experience on their own individual computing device. While the embodiments described generally refer to portable computing devices,  
10 it will be understood that non-portable computing devices, such as desktop computers, may also be used.

Real-time occurrences as referenced herein are those that are substantially current within the context of human perception and reaction.

15 Referring first to Figure 1, a schematic diagram of a portable computing device 100 in one embodiment of the collaboration system is shown. Shown are a central processor 102, a main memory 104, a timing circuit 106, a display interface 108, a display 110, a secondary memory  
20 subsystem 112, a hard disk drive 114, a removable storage drive 116, a logical media storage drive 118, a removable storage unit 120, a communications interface 122, a user interface 124, a transceiver 126, an auxiliary interface 128, an auxiliary I/O port 130, communications  
25 infrastructure 132, an audio subsystem 134, a microphone 136, headphones 138, a tilt sensor 140, and a central collaboration server 142.

Each of a plurality of portable computing devices 100, each used by one of a plurality of users (the  
30 plurality of users also referred to as a group), is networked in real-time to the central collaboration server (CCS) 142. In some embodiments, one of the

portable computing devices 100 could act as the central collaboration server 142. For the purposes of this disclosure, the central collaboration server 142 is its own computer system in a remote location, and not the  
5 portable computing device 100 of one of the users. Hence the collaboration system is comprised of the centralized central collaboration server 142 and the plurality of portable computing devices 100, each of the portable computing devices 100 used by one user.

10 The portable computing device 100 may be embodied as a handheld unit, a pocket housed unit, a body worn unit, or other portable unit that is generally maintained on the person of a user. The portable computing device 100 may be wearable, such as transmissive display glasses.

15 The central processor 102 is provided to interpret and execute logical instructions stored in the main memory 104. The main memory 104 is the primary general purpose storage area for instructions and data to be processed by the central processor 102. The main memory  
20 104 is used in the broadest sense and may include RAM, EEPROM and ROM. The timing circuit 106 is provided to coordinate activities within the portable computing device 100. The central processor 102, main memory 104 and timing circuit 106 are directly coupled to the  
25 communications infrastructure 132. The central processor 102 may be configured to run a variety of applications, including for example phone and address book applications, media storage and play applications, gaming applications, clock and timing applications, phone and  
30 email and text messaging and chat and other communication applications. The central processor 102 is also configured to run at least one Collaborative Intent

Application (CIA). The Collaborative Intent Application may be a standalone application or may be a component of an application that also runs upon other networked processors.

5           The portable computing device 100 includes the communications infrastructure 132 used to transfer data, memory addresses where data items are to be found and control signals among the various components and subsystems of the portable computing device 100.

10           The display interface 108 is provided upon the portable computing device 100 to drive the display 110 associated with the portable computing device 100. The display interface 108 is electrically coupled to the communications infrastructure 132 and provides signals to  
15 the display 110 for visually outputting both graphics and alphanumeric characters. The display interface 108 may include a dedicated graphics processor and memory to support the displaying of graphics intensive media. The display 110 may be of any type (e.g., cathode ray tube,  
20 gas plasma) but in most circumstances will usually be a solid state device such as liquid crystal display. The display 110 may include a touch screen capability, allowing manual input as well as graphical display.

          Affixed to the display 110, directly or indirectly,  
25 is the tilt sensor 140 (accelerometer or other effective technology) that detects the physical orientation of the display 110. The tilt sensor 140 is also coupled to the central processor 102 so that input conveyed via the tilt sensor 140 is transferred to the central processor 102.  
30 The tilt sensor 140 provides input to the Collaborative Intent Application, as described later. Other input

methods may include eye tracking, voice input, and/or manipulandum input.

The secondary memory subsystem 112 is provided which houses retrievable storage units such as the hard disk drive 114 and the removable storage drive 116. Optional storage units such as the logical media storage drive 118 and the removable storage unit 120 may also be included. The removable storage drive 116 may be a replaceable hard drive, optical media storage drive or a solid state flash RAM device. The logical media storage drive 120 may be a flash RAM device, EEPROM encoded with playable media, or optical storage media (CD, DVD). The removable storage unit 120 may be logical, optical or of an electromechanical (hard disk) design.

The communications interface 122 subsystem is provided which allows for standardized electrical connection of peripheral devices to the communications infrastructure 132 including, serial, parallel, USB, and Firewire connectivity. For example, the user interface 124 and the transceiver 126 are electrically coupled to the communications infrastructure 132 via the communications interface 122. For purposes of this disclosure, the term user interface 124 includes the hardware and operating software by which the user executes procedures on the portable computing device 100 and the means by which the portable computing device 100 conveys information to the user. In the present invention, the user interface 124 is controlled by the CIA and is configured to display information regarding the group collaboration, as well as receive user input and display group output. The CIA is described in more detail below in FIG. 3.

To accommodate non-standardized communications interfaces (i.e., proprietary), the optional separate auxiliary interface 128 and the auxiliary I/O port 130 are provided to couple proprietary peripheral devices to the communications infrastructure 132. The transceiver 126 facilitates the remote exchange of data and synchronizing signals between the portable computing device 100 and the Central Collaboration Server 142. The transceiver 126 could also be used to enable communication among a plurality of portable computing devices 100 used by other participants. In some embodiments, one of the portable computing devices 100 acts as the Central Collaboration Server 142, although the ideal embodiment uses a dedicated server for this purpose. In one embodiment the transceiver 126 is a radio frequency type normally associated with computer networks for example, wireless computer networks based on BlueTooth® or the various IEEE standards 802.11.sub.x., where x denotes the various present and evolving wireless computing standards. In some embodiments the portable computing devices 100 establish an ad hock network between and among them, as with a BlueTooth® communication technology.

It should be noted that any prevailing wireless communication standard may be employed to enable the plurality of portable computing devices 100 to exchange data and thereby engage in a collaborative consciousness process. For example, digital cellular communications formats compatible with for example GSM, 3G, 4G, and evolving cellular communications standards. Both peer-to-peer (PPP) and client-server models are envisioned for implementation of the invention. In a third alternative



embodiment, the transceiver 126 may include hybrids of computer communications standards, cellular standards and evolving satellite radio standards.

5 The audio subsystem 134 is provided and electrically coupled to the communications infrastructure 132. The audio subsystem 134 is configured for the playback and recording of digital media, for example, multi or multimedia encoded in any of the exemplary formats MP3, AVI, WAV, MPG, QT, WMA, AIFF, AU, RAM, RA, MOV, MIDI, etc.

10 The audio subsystem 134 in one embodiment includes the microphone 136 which is used for the detection and capture of vocal utterances from that unit's user. In this way the user may issue a suggestion as a verbal utterance. The portable computing device 100 may then capture the verbal utterance, digitize the utterance, and convey the utterance to other of said plurality of users by sending it to their respective portable computing devices 100 over the intervening network. In this way, the user may convey a suggestion verbally and have the suggestion conveyed as verbal audio content to other users. It should be noted that if the users are in close physical proximity the suggestion may be conveyed verbally without the need for conveying it through an electronic media. The user may simply speak the suggestion to the other members of the group who are in close listening range. Those users may then accept or reject the suggestion using their portable electronic devices 100 and taking advantage of the tallying, processing, and electronic decision determination and communication processes disclosed herein. In this way the present invention may act as a supportive supplement

that is seamlessly integrated into a direct face to face conversation held among a group of users.

For embodiments that do include the microphone 136, it may be incorporated within the casing of the portable computing device 100 or may be remotely located elsewhere upon a body of the user and is connected to the portable computing device 100 by a wired or wireless link. Sound signals from microphone 136 are generally captured as analog audio signals and converted to digital form by an analog to digital converter or other similar component and/or process. A digital signal is thereby provided to the processor 102 of the portable computing device 100, the digital signal representing the audio content captured by microphone 136. In some embodiments the microphone 136 is local to the headphones 138 or other head-worn component of the user. In some embodiments the microphone 136 is interfaced to the portable computing device 100 by a Bluetooth® link. In some embodiments the microphone 136 comprises a plurality of microphone elements. This can allow users to talk to each other, while engaging in a collaborative experience, making it more fun and social. Allowing users to talk to each other could also be distracting and could be not allowed.

The audio subsystem 134 generally also includes headphones 138 (or other similar personalized audio presentation units that display audio content to the ears of a user). The headphones 138 may be connected by wired or wireless connections. In some embodiments the headphones 138 are interfaced to the portable computing device 100 by the Bluetooth® communication link.

The portable computing device 100 includes an operating system, the necessary hardware and software drivers necessary to fully utilize the devices coupled to the communications infrastructure 132, media playback and recording applications and at least one Collaborative Intent Application operatively loaded into main memory 104, which is designed to display information to a user, collect input from that user, and communicate in real-time with the Central Collaboration Server 142.

5

10 Optionally, the portable computing device 100 is envisioned to include at least one remote authentication application, one or more cryptography applications capable of performing symmetric and asymmetric cryptographic functions, and secure messaging software.

15 Optionally, the portable computing device 100 may be disposed in a portable form factor to be carried by a user.

Referring next to FIG. 2, a collaboration system 200 is shown in one embodiment of the present invention.

20 Shown are the central collaboration server 142, a plurality of the secondary memory subsystems 112, a plurality of the timing circuits 106, a first portable computing device 202, a second portable computing device 204, a third portable computing device 206, and a

25 plurality of exchanges of data 208.

The group of users (participants), each using one of the plurality of portable computing devices 100, each portable computing device 100 running the Collaborative Intent Application, each device 100 in communication with the Central Collaboration Server 142, may engage in the collaborative experience that evokes a collective

30

intelligence (also referred to as Collective Consciousness).

As shown in Figure 2, the CCS 142 is in communication with the plurality of portable computing devices 202, 204, 206. Each of these devices 202, 204, 206 is running the Collaborative Intent Application (CIA). In one example, each of the devices 202, 204, 206 is an iPad® running the CIA, each iPad® communicating with the CCS 142 which is running a Collaboration Mediation application (CMA). Thus, we have the local CIA on each of the plurality of devices 202, 204, 206, each device 202, 204, 206 in real-time communication with the CMA running on the CCS 142. While only three portable devices 202, 204, 206 are shown in FIG. 2 for clarity, in ideal embodiments, dozens, hundreds, thousands, or even millions of devices 100 would be employed in the collaboration system 200. Hence the CCS 142 must be in real-time communication with many devices 100 at once.

The communication between the CCS 142 and each of the devices 202, 204, 206 includes the exchanges of data 208. The data has a very significant real-time function, closing the loop around each user, over the intervening electronic network.

As described above, the present invention allows the group of users, each using their own tablet or phone or other similar portable computing device 100, to collaboratively answer questions in real-time with the support of the mediating system of the CCS 142 which communicates with the local CIA running on each device 100. The Collaborative Intent Application ties each device 100 to the overall collaborative system 200. Multiple embodiments of the CIA are disclosed herein.

The Collaborative Intent Application (CIA) may be architected in a variety of ways to enable the plurality of portable computing devices 100 to engage in the collaborative processes described herein, with the  
5 supportive use of the Central Collaboration Server 142.

In some embodiments the exchange of data 208 may exist between portable computing devices 100.

Referring next to FIG. 3, a flowchart of one embodiment of a group collaboration process is shown.  
10 Shown are a collaboration opportunity step 300, a user input step 302, a send user intents to CCS step 304, a determine group intent step 306, a send group intent to CIA step 308, a display intents step 310, a target selection decision point 312, and a display target step  
15 314. The process also includes optional steps that could be included, for example, for the pointer graphical embodiment shown in FIG. 4: a display pointer start position step 316, a display input choices step 318, and an update pointer location step 320. In the collaboration  
20 opportunity step 300, the CIA receives the group collaboration opportunity from the CCS 142 and displays the opportunity on the display 110 of the portable computing device 100 (PCD). The group collaboration opportunity may be a question to be answered, for  
25 example, "What film will win the Best Picture in the Academy Awards?" or "Who will win the Super Bowl?" The process then proceeds to the user input step 302. The user input step 302 includes the user using the display 110 of the PCD 100 to input the user intent. The user intent is  
30 an input interpreted by the user interface 124 as a desired vector direction conveying an intent of the user. In some embodiments, e.g. FIG. 4, the user intent is a

desired vector direction of the graphical pointer 406 of the user interface 124, and the user input includes swiping of the pointer 406 via the touchscreen interface, as described further below in FIG. 4. The user input step  
5 302 takes place for each user of the group. The process then proceeds to the send user intent to CCS step 304.

In the send user intent to CCS step 304, the CIA for each PCD 100 sends the user intent to the CCS 142. In the next step, the determine group intent step 306, the CCS  
10 142 determines a collective group intent based on the plurality of user intents. The group intent may be determined through various methods, as described further below. The process then proceeds to the send group intent to CIA step 308.

In the embodiment including the optional steps  
15 display pointer start position 316 and the display input choices step 318, in the display pointer start position step 316 the graphical user interface 124 would display the starting, or neutral, position of a pointer 406  
20 chosen to indicate the graphical representation of the group intent. In the following step, the display input choices step 318, the user interface 124 would display a plurality of input choices 412 available to be selected by the group intent by using the pointer 406. The user  
25 intent in this embodiment is an input interpreted by the user interface 124 as representing that user's desired motion of the collaborative graphical pointer 406 with respect to the plurality of input choices 412.

In the send group intent to CIA step 308, the CIA  
30 receives the group intent from the CCS 142. Next, in the display intents step 310, for each PCD 100 the received representation of the group intent is displayed, along

with a representation of the user intent originally input by the user of the PCD 100. The process then proceeds to the target selection decision point 312.

5 The update pointer location step 320 may be inserted between the display intents step 310 and the target selection decision point 312. In the update pointer location step 320, in the embodiments including the pointer 410 the user interface 124 updates to indicate the current location of the pointer 406 in response to  
10 the received group intent.

In the target selection decision point 312, if the group intent received corresponds to selection of the target (in some embodiments, from among the input choices 412), the process proceeds to the display target step  
15 314, and the selected target is displayed on the display 124. If the group intent has not selected the target, the process returns to the user input step 302, and the process repeats until the target is determined by the group intent or until the process is otherwise ended (for  
20 example, by a time limit).

After the target has been chosen by the group intent, the entire process may repeat, for example, to form a word if each consecutive target is an alphabetic character.

25 Referring again to FIGS. 1, 2 and 3, the present invention in one embodiment employs the CCS 142 that users connect to via their portable computing device 100. In some embodiments, fixed or non-portable computing devices 100 can be used as well. In many embodiments,  
30 users choose or are assigned a username when they log into the CCS 142, thus allowing software on the CCS 142 to keep track of individual users and assign each one a

score based on their prior sessions. This also allows the CCS 142 to employ user scores when computing the average of the group intent of all the users (in embodiments that use the average).

5           In general, when the session is in progress, the question 400 (as shown below in FIG. 4) is sent from the CCS 142 to each of the CIA on the portable computing devices 100 of the users. In response to the question 400, the users convey their own intent either by  
10 manipulating an inner puck 410 of the pointer 406, as described further below, or by using a tilt or swipe input or other user interface methods as described further below. In these examples, the user's intent is conveyed as a direction and a magnitude (a vector) that  
15 the user wants the pointer 406 to move. This is a user intent vector and is conveyed to the CCS 142. In some embodiments, the magnitude of the user intent vector is constant. The CCS 142 in some embodiments computes the numerical average (either a simple average or a weighted  
20 average) of the group intent for the current time step. Using the numerical average, the CCS 142 updates for the current time step the graphical location of the pointer within a target board 404 displayed on the display 110. This is conveyed as an updated coordinate location sent  
25 from the CCS 142 to each of the CIA of participating users on their own devices 100. This updated location appears to each of the users on their individual devices 100. Thus they see the moving pointer 406, ideally heading towards an input choice 412 on the target board  
30 404. The CCS 142 determines if and when the input choice 412 is successfully engaged by the pointer 406 and if so, that target is selected as an answer, or as a part of the



answer (a single letter or space or punctuation mark, for  
example, that's added to an emerging answer). That  
target is then added to the emerging answer, which is  
sent to all the devices 100 and appears on each display  
5 110.

In some embodiments one of the input choices 412 is  
an "END" or "DONE" input choice, by which the group could  
choose to call the answer complete. In some embodiments,  
a PERIOD punctuation mark is an input choice. In yet  
10 another embodiment a time limit is included, after which  
the session is done, the answer complete. At this point,  
the process repeats with a new question being asked.

The CCS 142 may also be configured to compute scores  
for each user and transmit those scores to each device  
15 100. Or, the score could be determined locally by the  
CIA of each device 100 and be transmitted to the CCS 142  
for storage. Either way, the score can be computed based  
on the user's user intent vector during the session and  
how well it matched up with the group intent vector from  
20 the group as a whole (also called an average intent  
vector). The user who had a user intent vector that was  
substantially aligned during the time period of the  
response with the group intent vector is awarded points  
for the session, while a user who had a user intent  
25 vector that was substantially misaligned (for example,  
more than 180 degrees out of phase in direction), is  
awarded fewer points or loses points.

Referring next to FIG. 4, an embodiment of the user  
interface 124 of the CIA is shown in one embodiment of  
30 the present invention. Shown are the question 400, a  
group answer 402, the target board 404, the pointer 406,

an outer puck 408, the inner puck 410, and the plurality of input choices 412.

In the embodiment of FIG. 4, the user interface 124 is configured to support the collaborative answering of questions by a synchronous group of users working as a real-time dynamic system. In the embodiment shown in FIG. 4, the user interface 124 is modeled upon a traditional manual spirit board. When using the manual spirit board, a group of participants sits around a table, their fingers all touching a physical puck. One participant asks a question and then the puck moves around and picks out letters, eventually giving an answer. Nobody feels like they consciously moved the puck and yet it may produce a meaningful answer. Scientists have shown that spirit boards work because of involuntary motions in the hands of each participant. The participants are making the puck move, and yet each of them will swear that they didn't do anything. This makes it a model for this distributed collaborative interface, although the inventive system herein must employ a variety of clever techniques because the networked computer users will not be touching the same physical puck.

The embodiment shown in FIG. 4 uses the pointer 406 configured as a "puck within a puck". The outer puck 408 is controlled by the group intent and the inner puck 410 is controlled with respect to the outer puck 408 by each local user. In this way, each local user conveys his or her user intent on the inner puck 410, while watching the representation of the group intent as it's reflected in the motion of the outer puck 408, as described further below.

In another embodiment, a single puck is used, but the interface 124 allows each individual to swipe at the puck, imparting intent through the magnitude (i.e. the speed) and the direction of the swipe. In this way, each user watches the puck move under the collective will of the group, while individually swiping at the puck, again and again, trying to influence its motion.

In yet another embodiment, the 124 is a tilt interface, where each user conveys his intent by tilting the display 110 of the portable computing device 100 he or she is using. The user wants the puck to move left, he or she tilts the display 110 left. Of course, the puck is not responsive to the individual user but the group of users, its motion based on the group intent. In this way, the loop is closed around the individual users as they share a collective experience.

Referring again to FIG. 4, the embodiment shown will be described in more detail. As displayed on the display 110 of each user's portable computing device 100, the CIA displays three key pieces of information to each user - (1) it displays the current question 400 that is being posed to the group, (2) it displays the target board 404 of letters and numbers and words (input choices 412) that the users will collectively work to select among, and (3) it displays the pointer 406 that each user watches on their own device 100, and tries to influence, but which moves around the target board 404 based on the collective group intent. Those skilled in the art will note that the display interface 108 shown is one configuration based on an spirit board, and the user interface 124 could have many different visual configurations.

FIG. 4 represents the display 110 that is presented substantially simultaneously on portable computing devices 100 of all the networked users who are participating in real-time collaboration. In this example, let's assume that 100 people are using the system at once. At the start of a session, the question 400 appears appear at a top of the display 110, thus prompting the group of users that an answer is needed. This question 400 could also be conveyed through audio. At the start of the session, the answer 402 at the bottom would be blank, for it would not yet have been formulated by the group intent. In this exemplary display 110, the target board 404 includes input choices 412 of letters A-Z, numerals 0-9 and the words "YES" and "NO". The target board 404 may include other input choices 412, for example additional words or punctuation. In the embodiment shown in FIG. 4, the display 110 also includes the pointer 406, which is displayed as the outer puck 408 with the inner puck 410 at the pointer core, i.e. a "puck-within-a-puck" configuration. This is the graphical pointer 406 that will be moved around by the group under their collective control, to select letters, numbers, and/or words from the available input choices 412. Referring next to FIG. 5, a graphical representation of the puck-within-a-puck control algorithm is shown. Shown are the plurality of inner pucks 410, the plurality of outer pucks 408, a "no input" pointer configuration 500, a downward input pointer configuration 502, a rightward input pointer configuration 504, a general case pointer configuration 506, and a vector 508.

Each user is providing input by manipulating the inner puck 410 at the center of the pointer 406. In one embodiment, the user provides input by touching the inner puck 410 using a finger on a touchscreen. If the user is  
5 using a mouse or joystick or other device, the user could position a cursor on the inner puck 410. The key is that each user will input their individual user intent by manipulating the inner puck 410 portion of the pointer 406 with respect to the outer puck 408 of the pointer  
10 406.

A general key to extracting the collective group intent from the group is the method by which the pointer 406 is moved around each individual display 110, using input from the large number of users. One goal may be  
15 for the pointer 406 to move based on the numerical average (or weighted average) of the plurality of user intents so it's a real-time collaborative effort. This is critical, but creates challenges to overcome. If the individual user puts his finger on the pointer 406 (using  
20 his own touchscreen display 110) and moves his hand the way a typical user interface would work, his finger/pointer location would diverge from what other users are seeing on their displays 110. This would ruin a collaborative experience, for every user would see their  
25 own version of the pointer 406 moving based on their own finger location. That's not a synchronized collaborative experience. The pointer 406 has to move based on the group intent, not the input of any individual user. But this creates the alternate problem - if the pointer 406  
30 moved based on the numerical average (or other summation) of the plurality of user intents, each individual user would see the pointer 406 on his display 110 move away

from his own finger location, like he had no influence over it at all.

In the pointer control embodiment shown in FIG. 5, the user is advantageously able to see the group intent as it's reflected in the pointer location, and also have a means of viewing his own individual user intent. This is solved in the embodiment of FIG. 5 by employing the puck-within-a-puck pointer 406. In the example shown, the inner puck 410 and the outer puck 408 are each circles, with an outer puck circle surrounding an inner puck circle. Other graphical representations could be devised.

The inner puck 410 is what the individual user will manually manipulate, on his personal computing device 100. The outer puck 408 is controlled by the group as a whole, based in one embodiment on the weighted average of the plurality of user intents. Each user is given two instructions by the CIA. First, they are told they must keep the inner puck 410 inside the outer puck 408, even when the outer puck 408 is moving based on changing group intent. Second, the user is to try to move the outer puck 408 towards the input choice 412 that they believe will best answer the question 400 that was posed. But, the only way the user can influence the outer puck 408 is using the inner puck 410. Some examples of user intent are shown in FIG. 5.

"No input" pointer configuration 500 shows a relative location of the user-controlled inner puck 410 and group-controlled outer puck 408 corresponding to the user not imparting any desired motion on the pointer 406. This means that the user is not imparting any input to help guide the outer puck 408. In the downward input

pointer configuration 502, the inner puck 410 has been moved by the user to near a bottom edge of the outer puck 408. Thus, the downward input pointer configuration 502 show a relative location of the user-controlled inner  
5 puck 410 and the group-controlled outer puck 410 corresponding to the user imparting a downward desired motion on the pointer 406 (i.e. a downward user intent). In the rightward input pointer configuration 504, the inner puck 410 has been moved by the used near to a right  
10 edge of the outer puck 408. Thus, the rightward input pointer configuration 504 shows a relative location of the user-controlled inner puck 410 and group-controlled outer puck 408 corresponding to the user imparting a rightward desired motion on the pointer 406 (i.e. a  
15 rightward user intent). In the general case pointer configuration 506, the inner puck 410 is moved by the user towards an edge of the outer puck 408, defining the vector 508 from the center of the outer puck 408 to the center of the inner puck 410. The general case pointer  
20 configuration 506 shows a relative location of the user-controlled inner puck 410 and the group-controlled outer puck 408 corresponding to the user imparting a generalized desired motion on the puck in vector 508 (i.e. a generalized vector direction user intent). The  
25 vector 508 corresponds to the user intent vector and includes the direction the user wants the outer puck 408 to move.

In some embodiments, the magnitude of the vector 508 (the user intent vector) is constant, only the direction  
30 changing with the user's motion of the inner puck 410 relative to the outer puck 408. In other embodiments, the magnitude of the vector 508 varies based on how close the

inner puck 410 is to the edge of the outer puck 408. The closer to the edge of the outer puck 408 the inner puck 410 has been moved, the stronger the magnitude of the vector 508.

5           In this way, each user inputs the user intent vector comprising the magnitude and the direction for which he wants want the outer puck 408 to move within the target field. In one embodiment the outer puck 408 moves based on the weighted average of the plurality of user input  
10           vectors. Each user sees the outer puck 408 drawn on their display 110 at a location based on the combined group intent based on the input vectors from all the users, the location being updated in real-time (based on data received from the CCS 142). This means each individual  
15           user is imparting will by controlling the inner puck 410 on their display 110 in relation to the outer puck 408 that is being controlled by the group as a whole (as determined via from the CCS 142). This allows the user to feel like he is directly influencing something on the  
20           local device display 110, while also interacting with something controlled by the group at large. Together, the group will direct the outer puck 408 to target input choices 412, to collaboratively answer the question 400 posed.

25           Although the example embodiment provides the outer puck 408 controlled by the group intent and the inner puck 410 controlled by each individual user, this configuration can be inverted such that an inner graphical element (analogous to the inner puck 410) is  
30           controlled by the group intent and the users control the motion of an outer graphical element (analogous to the



outer puck 408) with respect to the inner graphical element.

As described herein, the user intent vector is updated in real-time. As each user conveys intent on the user interface 124, the user intent vector is computed by the local CIA. This user intent vector is communicated to the CCS 142 as data. The data may include the direction that the user desires the puck to move, and the magnitude of desire. This user intent vector is received by the CCS 142, along with user intent vectors from each of the plurality of users. The CCS 142 then computes, in one embodiment, the average vector (or weighted average, or other summation of input) to derive the group intent vector. This group intent vector represents the collective will that the group imparts on the pointer 406 at a current moment in time. The group intent vector is then used to update the coordinate location of the outer puck 408. The updated coordinate is then sent to each of the plurality of devices 100. Each of the users then sees the outer puck 408 move on their display 110, based on the collective group intent. Each user then modifies his input (closing the loop), thus conveying a new user intent vector to the CCS 142, and the process repeats. This happens until the pointer 406 selects one of the input choices 412 as the target, which is then added to the group answer 402, as previously described in FIG. 3. In this way, the group of distributed users, each on their own portable computing device 100, collaborates in real-time to answer questions, and thus evoke the collaborative consciousness.

In one example of implementation of the system, 100 users using 100 portable computing devices 100 are

waiting for the session to start. The question 400 then appears on each of their displays 110, sent to them by the Central Collaboration Server 142: "Who will win the NCAA Tournament?" This question could have been proposed  
5 by one of the 100 users, a right awarded to that user by the CCS 142 as a consequence of his or her participation. Questions could be queued on the CCS 142, input from many users, and sent out in an order determined by the CCS 142 to the plurality of portable computing devices 100. In  
10 some embodiments, the user who earns enough points as a result of accurate participation (participation that is in-sync with the group as a whole), is awarded the right to ask a question.

Regardless of the method by which the question 400  
15 was generated, it is selected by the CCS 142 and sent at a substantially simultaneous moment to the 100 portable computing devices 100 of the 100 users, the question 400 appearing as text on the displays 110 of the 100 portable computing devices 100. Also displayed on the display 110  
20 of each of the 100 users is the target board 404 with a field of input choices 412 (which may be answers or elements of answers). The field of input choices 412 could be text and letters, as shown in FIG. 4, or the input choices 412 could be words - the names of all the  
25 NFL teams, the names of the months, the colors of the spectrum, etc. Regardless of the specific field of input choices 412, each user imparts his intent by moving the inner puck 410 relative to the outer puck 408. The outer puck 408 starts to move based on the numerical average, or weighted average, of the group intent. In this way a  
30 first letter of the answer 402 is targeted - "S". Once this letter is targeted, it appears at the bottom of the

display 110 (or in an otherwise designated area), as part of the emerging answer 402. The emerging answer 402 is now "S". The pointer 406 is then re-set to the center of the display 110 for all users, as triggered by data sent  
5 from the CCS 142. Because the CCS 142 is sending the display location of the pointer 406 to all the portable computing devices 100, this reset can be achieved at least in part by the CCS 142 sending coordinates for a home position (center of display 110, for example), of  
10 the pointer 406, to all the portable computing devices 100.

The users then repeat the process, imparting their individual user intent on the inner puck 410 with respect to the outer puck 408, thereby sending the user intent  
15 vectors to the CCS 142, which computes the average (natural or weighted) and generates another group intent vector, using it to update the location of the outer puck 408. The process repeats until the outer puck 408 targets another element of the answer 402, in this  
20 example "T". The letter T is added to the emerging answer 402 "ST" at the bottom of the displays 110 of all the users. The process repeats, letters being collectively selected, one after another, until the full answer 402 to the question 400 is achieved - "STANFORD".  
25 And thus, the group has collectively answered the question 400 through a real-time closed loop synchronized emergent process. This answer 402 is not a poll. It is not a survey. It is the real-time collaboration, the loop being closed around input and output.

30 It is advantageous to the system to ensure that the inner puck 410 of each individual user stays within the outer puck 408 being moved based on collective input. In

one embodiment, the inner puck 410 is not allowed leave the outer puck 408. The inner puck 410 butts up against an edge instead and is prevented from exiting. In some cases this will mean the inner puck 410 is dragged along  
5 by the moving outer puck 408. In another embodiment, the user receives a penalty if he allows the inner puck 410 to exit the outer puck 408, losing points in the score he is generating for the session. The score can be like a game, users trying have the highest score possible. This  
10 means each individual user is trying to keep the inner puck 410, which is under his individual control on his display 110, inside the outer puck 408 that is moving according to the group intent, based on coordinates received from the CCS 142. At the same time, individual  
15 users are trying to influence the outer puck 408 based on the where inside the outer puck 408 he positions the inner puck 410 - whichever edge of the outer puck 408 the inner puck 410 is positioned on will convey the user intent vector from that user as described previously. The  
20 user can get a score based on (a) how well he keeps his inner puck 410 inside the outer puck 408 (prevents it from leaving), and/or (b) how well that user's user intent vectors were aligned with the group intent vector during the session. This means the system can be  
25 configured to award each user points based on how well he keeps the inner puck 410 from leaving the outer puck 408 while trying to guide the outer puck 408 towards targets that form a coherent answer. To incentivize guiding the outer puck 408, not just staying within it, users can be  
30 given a cumulative score that is posted on his display 110 (and optionally shared with all users) based on how skillfully he guided the outer puck 408 in the direction

of the group intent vector. This score can also be used for weighting user's inputs and/or for granting users the ability to ask questions. Points can be computed in a variety of ways depending on the input method used to control the pointer 406.

To incentivize users to keep the inner puck 410 inside the outer puck 408, but also try to move the outer puck 408 towards desired targets, the points system can be implemented such that users earn points if they are imparting the user intent vector (direction and magnitude) on the outer puck 408 that's heading in the direction that the outer puck 408 is currently moving based on the group intent. In other words, when the individual user inputs the user intent vector that contributes constructively with the group intent, they earn points. Conversely, if the user tries to move the outer puck 408 in a way that opposes the group intent, applying the user intent vector that is not substantially in the current direction of motion of the outer puck 408 (i.e. contributing destructively), the user loses points. Thus, points are awarded for the user "in sync" with the group intent, and points are lost for the user "out of sync" with the group intent. This means each individual user can convey his individual will/intent, but he is also incentivized to help make sure the pointer 406 moves across the display 110 and targets meaningful letters, numbers, and/or words.

Thus, if the individual user's input during the session was constructive (i.e., his input helped guide the pointer 406 towards the targets that made up the answer 402), that user earns points. But, if the individual user's input contribution during the session

was destructive (i.e., the input opposed the motions of the pointer 406 as it selected targets and made up the answer 402), then that user loses points. A skilled user is thus the user whose will is generally  
5 constructive (in-sync) with the will of the group. This is true not only for the puck-within-a-puck method of conveying individual user input methods but also for alternate methods of conveying user intent vectors (including the tilt method, the swipe method, and the  
10 inverse method).

Targeting occurs when the outer puck 408 touches or envelopes one of the input choices 412. Once this occurs, the selected target is added to the answer 402 that is forming on the display 110. For example, if "B"  
15 was selected as a first letter in the answer 402, it would appear beside the phrase "ANSWER", as the first letter in an emerging word. If the next letter selected was "L", that target would appear next. The full answer 402 might appear as shown in FIG. 4: "BLUE". Thus, the  
20 answer 402 appears in real-time. Also, once the target is selected, the pointer 406 could be reset to a center of the display. The users then work together to select the next letter, number, or word.

One embodiment of the graphical pointer 406 designed  
25 to visually highlight a central target area that must enclose the input choice 412 is shown in FIGS. 6 and 7. When using this pointer design, the target is selected when the pointer 406 is positioned by the group intent such that the input choice 412 is substantially within  
30 the central target area 600. For example, in FIG. 7, the letter "S" would be the target selected from among the available input choices 412.

In some embodiments, "BACKSPACE" and/or "DELETE" may be included as one of the input choices 412. For example, if it turns out that one or more of the already selected letters in the emerging answer 402 is not going to work coherently in the emerging word or sentence, the group would be hereby abled to target "BACKSPACE" (or "DELETE"), allowing the last target added to be deleted and then replaced by a new target. In addition, the system could require an icon or other representation for a "SPACE BAR" and/or basic punctuation, all of which may be selectable by the group to form words, sentences or even paragraphs collaboratively.

In some embodiments, users who earn points as described above, can "win" the right to ask the question 400 to the group (as it appears at the top of the display 110). For example, the user with the highest score for a given period of time could be the one who asks the next question. Or users could line up in a queue for asking questions, their entry into the queue and/or their placement in the queue, being based on their score for a period of time. This means, skilled users get to ask more questions to the group. This also gives users an incentive to perform "in-sync" with the group intent.

In some embodiments the group intent is based on the simple numerical average (vector sum) of the user intent vectors (direction and magnitude) collected from all the users. In other embodiments, the user who has earned a higher score (based on past performance), could be granted higher weighting by the CCS 142 when it computes the numerical average. Or, users who have spent more time on the system could be granted higher weighting by the CCS 142 when it computes the average. In this way,

the CCS 142 could assign to each user a user weighting factor that weights the relative importance of that user's user intent vector as compared to the user intent vectors from the other users who are participating, when  
5 computing the resultant group intent vector. Embodiments that reward users with higher weighting factors based on higher scores and/or more participation time, gives incentive for users to function "in-sync" with the group, and to participate more often.

10 Hence, the contribution that each user has upon emergent group intent can be scaled using weighting factors such that some users have a greater impact than others based on their accuracy/value of their prior input and/or based on the amount of participation the user has  
15 had on the system. Each user will thus be associated with a variable called a user contribution index, which indicates the user's level of contribution to the overall group intent, this factor being used to scale the user's contribution to the weighted average.

20 In some embodiments, the CCS 142 may be configured to allow the group to collectively decide who asks the next question, or to collectively select the next question from a queue of pending questions. For example, the plurality of users could enter questions into their  
25 portable computing devices 100, all of which are routed to the CCS 142, which then routes the list or otherwise causes the list of pending questions to be displayed locally on the local device displays 110. The plurality of users can then control the pointer 406 (or use other  
30 methods disclosed herein) to collectively select which question to answer next. Once this question is selected, the question 400 is presented to the group, and the group



collectively selects among the input choices 412 (e.g. letters, words, numbers, and/or punctuation) to form the answer 402.

In some embodiments, users selectively form the next  
5 question, by selecting letters, numbers, words, and  
punctuation from the input choices 412. In some  
embodiments, two collective collaboration servers 142  
could be employed at once, each with a separate group of  
users. A first server can allow a first group of users  
10 to collectively ask a question of a second group of users  
of a second server. The second group of users of the  
second server can respond to the question posed by the  
first group of users of the first CCS server. This  
process could repeat, with questions and answers going  
15 back and forth between the first server and the second  
server, and vice versa.

Referring next to FIG. 8, an embodiment of the  
target board 404 for use with the tilt and swipe input  
method is shown. Shown are the question 400, the group  
20 answer 402, the target board 404, the pointer 406, and  
the plurality of input choices 412.

One aspect of the "puck-within-a-puck" method  
described above is that the user concentrates on keeping  
the inner puck 410 within the outer puck 408, which takes  
25 mental focus. For versions that require less focus, the  
screen tilt input method may be employed as the user  
interface method. In such an embodiment, all users watch  
the pointer 406 on their display 110, its location  
updated based on the group intent. The group averaging  
30 methods can be the same as described above, but in this  
embodiment each user's user intent vector is based on the  
tilt of that user's portable computing device 100 (rather

than on the relative location of that user's inner puck  
410 with respect to the outer puck 408). The magnitude  
and direction of the tilt, conveys that user's user  
intent vector, which is sent to the CCS 142 and averaged  
5 into the group intent vector, which is used to update the  
location of the pointer 406. With respect to FIG. 8, the  
target board 404 shown on the display 110 is shown with  
the pointer 406 and the field of input choices 412. The  
user who looks at this display 110 on the portable  
10 computing device 100, and wants to make the pointer 406  
go towards the letter "G" would tilt the device 100  
rightward. The user who looks at the display 110 and  
wants to make the pointer 406 go towards the letter "T"  
would tilt the display 110 leftward. If the user wanted  
15 to target the letter "A" the user would tilt the device  
100 upward, etc. But, the pointer 406 does not move based  
on the individual user's intent, but based on the group  
intent.

This means the user might be watching the pointer  
20 406 head for the letter "L" at the bottom of the display  
110, but he wants it to head for the letter "Z" on the  
top of the display 110, so that user tilts the device 100  
upward, thus conveying the user intent vector in that  
direction (to be added to the group intent). Again,  
25 scoring can be based on how well the user's user input  
vector (now based on tilt), matches the average group  
input vector across the collective group. In lieu of the  
screen tilt input method, users on desktop computers or  
other devices 100 not compatible with the screen tilt  
30 input method could convey the user input vector with the  
mouse or other input device, rather than tilt.

When using the swipe input method, the user executes a swipe gesture by sliding his finger across the pointer 406 on his display 110 in a rapid slash motion. The swipe gesture conveys the user intent direction (direction of the swipe) and the user intent magnitude (speed of the swipe) that comprises the user intent vector (magnitude and direction). Data that represents the user intent vector is then sent from the portable computing device 100 of that user to the CCS 142 over the communication link. The same is true for the plurality of other users, who also issue swipe gestures to the pointer 406 displayed on their own portable computing device 100. As with the examples above, the location and motion of the pointer 406 on the display 110 of any single user's portable computing device 100 is not directly responsive to that user's swipes, but is responsive to the collective average of swipes across the plurality number of users, which are averaged into the group intent vector (as described above). This can be thought of as an average swipe vector across the plurality of users. The average swipe vector can be computed through a direct vector summation or through a weighted vector summation of the individual swipes executed by users during a period of time. In one example, the time period is 1 second. Thus every second the CCS 142 computes the group intent vector (or average swipe vector) across all user intent vectors it received during that period from portable computing devices 100. Using that group intent vector (magnitude and direction), the CCS 142 updates the coordinate location of the pointer 406, and sends the updated coordinates to the portable computing devices 100. The users all see the

updated location and issue more swipes, either trying to coax the pointer 406 in the direction the pointer 406 is already heading (constructive), or trying to coax the pointer 406 in a new direction (destructive) by  
5 repeatedly swiping at the pointer 406 with updated directions and magnitudes.

One of the many functions described above for the software running on the CCS 142, is to rapidly compute the group intent vector (GIV) based upon the plurality of  
10 user intent vectors (UIV) that have been received for the particular prior time period. In an example, the time period is 0.25 seconds and there are 100 users contributing. Thus, four times per second the CCS 142 receives 100 User Intent Vectors, each comprising a  
15 magnitude and direction. These 100 values are represented as  $UIV_1, UIV_2, UIV_3 \dots UIV_{100}$ . Thus, in the simplest embodiment the group intent vector can be computed as  $GIV = (UIV_1 + UIV_2 + UIV_3 + \dots UIV_{100}) / 100$ . In more  
20 sophisticated embodiments, the weighted average can be used wherein each  $UIV_n$  is scaled by a user weighting factor that adjusts the relative importance of that user's input to the resultant GIV. For each user's weighting factor  $UWF_n$  the GIV is computed as follows:

$$25 \quad GIV = (UIV_1 \times UWF_1 + UIV_2 \times UWF_2 + UI \times UW + \dots UIV_{100} \times UWF_{100}) / 100$$

The location of the pointer 406 is then updated using the magnitude and direction components of the GIV for that period of time. This is repeated, time-step after time-step, making the pointer 406 move smoothly under the  
30 collective collaborative control of the 100 users, closing the loop around each of them, for they can see in

real-time (or near real-time) the motion of the pointer 406 based on the group intent.

In some embodiments the magnitude of the user intent vector is computed not based on the velocity of the swipe executed by the user on the pointer 406, but based on the frequency of repeated swipes executed by the user during a polling interval. For example, the polling interval could be 2 seconds, therefore the user could be repeatedly issuing swipes to the pointer 406 during that period. The CIA on the local device 100 keeps a running summation of the swipes, determining the magnitude based on the plurality of swipes executed by that user during the polling period. The CIA software can be configured to compute a vector sum of the plurality of swipes executed by the user, the direction and magnitude of the vector sum being an additive result of the plurality of swipes. Thus if the user executed many swipes during the polling period and if the many swipes were substantially in the same direction, thus adding to a high magnitude in that direction, the user intent vector, as derived from the swipe vector sum, will be of a high magnitude in the repeatedly swiped direction. This allows the user to aggressively and actively swipe at the pointer 406, again and again, as fast as they can, to increase the magnitude of the user's user input vector.

Referring next to FIG. 9, an embodiment of the display 110 using the inverse input method is shown. Shown are the question 400, the target board 404, the pointer 406, the plurality of input choices 412, and the input wheel 900.

In some embodiments, the inverse input control method can be employed where the pointer 406 remains

fixed on the display 110 on the screen of each user's portable computing device 100, but the background field of input choices 412 is moved in response to the collective input of the group, such that the input  
5 choices 412 in the background field are targeted. One such method employs the input wheel 900 that is collectively rotated until a desired letter (or other input) is positioned so as to be targeted by the fixed pointer 406. There are a number of ways this can be  
10 configured.

In FIG. 9, the rotatable graphic input wheel 900 is displayed by the CIA app of the portable computing device 100 of the users, with the fixed pointer 406 displayed in a location relative to the input wheel 900. In a typical  
15 computer interface, the user might directly manipulate the input wheel 900, but not here. In this user interface 124, each user can swipe at the input wheel 900, imparting the user intent vector that indicates the direction and magnitude of wheel spin desired by that  
20 user so as to position the desired target input choice 412 under the pointer 406. The user intent vectors from the plurality of users is sent from their portable computing devices 100 to the CCS 142. The CCS 142 computes the summation of the user intent vectors (either  
25 the simple average or the weighted average or another algorithmic summation), and produces the group intent vector. This represents the collective will of the group at this moment in time, with respect to how the input wheel 900 should rotate (direction and magnitude of  
30 rotation for this time period). An updated orientation of the input wheel 900 is then sent from the CCS 142 to each of the plurality of portable computing devices 100,

each of which updates the display 110 of the input wheel 900 for its user. The updated orientation may only change by a few degrees each cycle (or possibly less), so it looks like smooth rotations to the users, and not  
5 jumpy. Users could issue repeated rapid swipes to the wheel 900, conveying their intent based on repeated frequency, as described in the swipe input method above (the repeated swipes summed during repeated polling periods, as described above).

10               Targets may be selected for the emerging collective answer 402 when the collaborative motion of the input wheel 900 is such that the particular input choice 412 is positioned under the pointer 406 for more than a threshold amount of time, e.g. 3 seconds. Thus if  
15 the wheel 900 rotates such that the letter "S" is positioned below the pointer 406 indicator, and remains substantially below the pointer 406 indicator for more than the threshold period of 3 seconds, that letter is selected, and added to the emerging text answer 402 that  
20 appears letter-by-letter on the display 110. In some embodiments, multiple input wheel/pointer pairs could be displayed at once on the display 110, allowing the users to collectively select a sequence of letters that are all visually displayed at once, as shown in FIG. 10.

25               In some configurations of FIG. 10, the users could be restricted to manipulating the input wheels 900 collectively in a sequential order, left to right, causing the answer 402 to form. In other configurations the users could collectively control the plurality of  
30 input wheels 900 at the same time, thus causing the answer 402 to form, not letter by letter, but in a more organic manner. Any number of input wheels 900 could be

used, and they could include not just letters but numbers, words, punctuation, delete and space, and other icons. In some embodiments the input wheels 900 could be displayed graphically as a cylindrical drum. In other  
5 embodiments the input wheels 900 could be replaced by flat sheets (fields) with input choices 412 upon them, the whole flat sheets being collectively moved planarly (in the plane) with respect to the fixed pointer 406. The fixed pointer 406 as shown in FIGS. 9 and 10 is shown as  
10 an arrowhead, but the pointer 406 could be a magnifier or a crosshair or other graphical indicator.

In some embodiments the CCS 142 may be configured not just to stream answers to the participants who are engaged in the session, for display to them, but also  
15 once the answer 402 appears as a fully formed response the CCS 142 could use Twitter to tweet the answer 402. Alternately the CCS 142 may be configured to convey the message using other forms of social media. This creates an expressive collaborative intelligence that issues its  
20 own tweets, expressing itself as an artificially produced consciousness to the world. This collective consciousness can be given a name in some embodiments, for example the name "UNUM" which means "The One" in Latin. This means, a feature of the CCS 142 software is  
25 enabled such that that once the answer 402 is complete, or once the answer 402 reaches a certain length (e.g. 140 characters), the answer 402 gets tweeted from @UNUM. Similarly, the answer 402 may be selectively posted by the CCS 142 on a dedicated website or Facebook page or  
30 other social media outlet. In addition, statistics about the answer 402 may be selectively posted along with the



answer 402, including the number of participants who contributed to the answer 402.

In another embodiment, followers of UNUM on Twitter may be configured as the ones who ask questions to the collective consciousness, and then get the answer 402 through a resulting tweet. This can be enabled by linking the Twitter feed to the CCS 142 or to the CIA, routing incoming questions from Twitter into the CCS 142, and then routing resulting answers 402 from the CCS 142 to Twitter as tweets. In some embodiments, synthesized voice output may be used to read aloud the emergent answer 402 to each given question.

In addition to passing data that represents the changes in location between the pointer 406 and the targets, as a result of group input from the plurality of users, the CCS 142 and the CIA can be configured to pass data about and/or present data about the collaborative process that generated a particular answer. For example, during the session, while users are participating in the collaborative answer forming process, the CCS 142 can be configured to send data to the CIAs of the individual users, indicating the current number of participating users who are contributing to the response at that time. This number can be displayed upon the display 110 of individual portable computing devices 100 by the CIA. In addition, the CCS 142 can compute a convergence index that indicates how well the group is currently working towards a common goal, the group input being additively constructive or destructive. The convergence index can be computed as an absolute value of the group intent vector, for if the current group intent vector has a high absolute value (magnitude), then the group of users must

be contributing in a constructive additive manner. But, if the current group intent vector value has a low absolute value (magnitude), then the group of users must be canceling each other out, their user intent vectors  
5 being in substantially different directions. This value is computed by the CCS 142 and passed to the CIA on individual devices 100. It can then be displayed in real-time to the users of the individual devices 100 while they participate. The convergence index can be  
10 configured to be represented as a value from 0 to 100 (thus a percentage) wherein 0 would indicate that the group of users are in a stalemate, or near stalemate, their user intent vectors combining to a 0 magnitude and the pointer 406 is stationary. Conversely a 100 value  
15 for the convergence index would indicate that the users are all urging the pointer 406 in the same direction, the pointer 406 moving at maximum speed. In some embodiments the convergence index is graphed, showing users how the convergence index is changing over time during the course  
20 of the question answering session. In other embodiments, the elapsed time over which the answer 402 was formed, from the time the question was posed until the answer 402 was complete, is tracked by the CCS 142 and presented to the users (via the CIA) upon completion  
25 of the answer 402. In some embodiments, scores are computed for users based on how "in-sync" they were with the emerging collaborative response (as described previously). In such embodiments, the CCS 142 can determine the high scorer and/or high scorers for a given  
30 session, or a number of sessions, and post a list of high scorers so the users know which user (by username) was the most effective contributor to the emergent answer, or

answers 402. This allows users to engage in a competitive spirit that drives users to be constructive, not destructive, to the emerging collective will.

In some embodiments, a maximum speed of pointer motion is limited, for if the speed is too high it's too difficult for users to contribute effectively.

In some embodiments, pointer motion is given simulated inertia, such that once the pointer 406 is moving in a particular direction, it has momentum in that direction (using a mass simulation equation), and thus will continue to drift in that direction, slowing based on a simulated friction coefficient.

In some embodiments, a coherence support algorithm is employed by the CCS 142 that bars users from collectively selecting sequential letters that do not form a word in the language being employed. For English, for example, a spell checker engine is used to determine what letters are valid "next letters" in the emerging answer 402 and only allow the users to choose from those letters as they select the next element in the answer 402. In such embodiments, the available letters could be highlighted (or the unavailable letters could be dimmed or could disappear from the target display) as the users try to select the appropriate next letter. Thus, for example, if a word is forming collectively and it so far spells "THEI", there are a limited number of letters that can follow that sequence and form a valid word. The letter "Q", for example is NOT part of any valid word in the English language, following that sequence, and thus it can be BARRED from selection by the users by the CCS 142, or by a local routine on the CIA. In the server-controlled embodiment, the CCS 142 can send regular

updates of barred letters as the answer 402 is forming.  
The coherence support algorithms are critical for  
ensuring that responses are NOT gibberish, but real  
words. As sentences form collectively, a grammar support  
5 algorithm could be employed to ensure that words chosen  
in sequence (separated by spaces) are only allowed that  
make grammatical sense.

For embodiments where there is only one possible  
letter that can complete the valid word, the CCS 142 can  
10 auto-complete the word, thus making the word formation  
process faster and more efficient. The users could still  
collectively input BACKSPACE, if they wish to erase the  
autocomplete.

In some embodiments, when the valid word has been  
15 produced collectively by the group such that no  
additional letter could be added to it and have it remain  
valid, the CCS 142 can automatically select SPACEBAR and  
thus speed the formation of a sentence.

In some embodiments, each user's user intent vector  
20 can be imparted into the portable computing device 100  
using a camera or other eye-tracking means, the user  
intent vector being based on the gaze location of the  
user in part or in combination with tilt, finger  
location, and/or swipes. For example, the user's gaze  
25 might be aimed at the edge of the pointer 406 that  
corresponds with the direction the user wants the pointer  
406 to go. The angle from the center of the pointer 406  
to the edge of the pointer 406 where the user's gaze is  
aimed, can be used to compute the user intent vector.  
30 Or, the user's gaze could be aimed at the actual target  
location, and the angle from the center of the pointer  
406 to the location where the user's gaze is aimed can be

used to compute the user intent vector. The user intent vector is then communicated to the CCS 142 by the CIA, as described previously.

For some embodiments, especially embodiments that  
5 support large numbers of users, multiple pointers 406 are employed simultaneously on the target board 404, enabling users to collectively move said multiple pointers 406 in parallel. This works well with swipe embodiments, where the user can selectively swipe at more than one of the  
10 pointers 406 (not at the same time) to convey his or her intent on how each of the multiple pointers 406 should move. In such an embodiment the CIA from the individual user's portable computing devices 100 reports multiple user intent vectors to the CCS 142, one user intent  
15 vector for each pointer 406 the user conveyed intent with respect to. Thus if there were three pointers 406 on the display 110, and the user swiped sequentially at all three, conveying his or her intent for how each of the three pointers 406 should move, the CIA app would report  
20 three user intent vectors (UIVA, UIVB, UIVC) to the CCS 142. The CCS 142 would compute the group intent vector for each of the three pointers 406 that are being controlled collectively by the plurality of users, and report updated coordinate locations back to the portable  
25 computing devices 100 for each of the three pointers 406 being controlled collectively by the plurality of users. In this way, multiple pointers 406 can be collectively controlled by the plurality of users in parallel. In some embodiments, each of the multiple pointers 406 is  
30 given a different visual label on the display 110 or other unique identifier or unique shape, so it can be distinguished from the other of the pointers 406. In

some such embodiments, each of the multiple pointers 406 is assigned a unique function with respect to the other pointers 406. For example, a first pointer can be assigned a task of selecting the next element in the emerging answer 402, a second pointer can be assigned a task of selecting the element after the next element in the emerging answer 402, and a third pointer can be assigned a task of selecting the element after the element after the next element of the emerging answer 402. And, when the first pointer selects the target element, the roles shift, with the second pointer now assigned the task of selecting the next element, the third pointer now assigned the task of selecting the element after the next element, and the first pointer is now assigned the task of selecting the element after the element after the next element in the emerging answer 402. This can be thought of as a rotating queue where a pointer gets to the back of the line after it successfully selects one element in the emerging answer 402. In this way, multiple pointers 406 can move about the display 110 in parallel, heading towards the next element, an element after the next, an element after that, (and optionally more next elements), all controlled collectively by the users. This allows answers to emerge faster. (Typing is analogous to this technique. An individual typing will aim for a key to hit, while also positioning his finger over the next key to hit. Without doing these actions in parallel, typing is slow. The control of pointers 406, in parallel, collectively, is thus a highly innovative method for allowing the group of users to act the way a single human brain does, thinking ahead and getting ready for a next action to come).

Referring next to FIGS. 11 and 12, the target board 404 in an additional embodiment of the inverse target method is shown. Shown are the answer 402, the plurality of input choices 412, a plurality of input choice copies 1200, and underscore elements 1202.

Using the embodiments above that enable the group of users to collectively control multiple moving objects on the display 110 in real-time, the inverse input method can also be employed where there are no pointers to aim at input choices 412 but instead, the input choices 412 themselves are moved about the display 110, chosen from the field of input choices 412. As shown in FIG. 11, the field of input choices 412 can be displayed for the users. In this case the input choices 412 are letters, but the input choices 412 may also include numbers and punctuation, as well as SPACEBAR and DELETE functions. The input choices 412 may also include words, as described previously. In this embodiment, users can swipe at one or more input choices 412, and a copy of that input choice 412, the input choice copy 1200, will start to move. Collectively, the users are instructed to arrange the input choices 412 in order, so as to form the word or words that answer the question posed (or otherwise convey the collective intent of the group). In this way, multiple input choices 412 can be moved at once, all converging on the answer area (which is shown as underscores in FIGS. 11 and 12). As the users swipe at the input choice copies, conveying user intent vectors, the input choice copies move based on the group intent, some input choice copies moving faster than others. The input choice copy 1200 may head to a first underscore element 1202 of the answer 402, and other

input choice copies 1200 may head towards other  
underscore elements 1202 of the answer 402. The result  
is the word forming in parallel, the letters seeming to  
arrange themselves. When spacebar and punctuation is  
5 allowed, entire sentences can form in parallel this way.  
The lexical coherence support methods described  
previously can also be employed, blocking some letters  
from filling some underscore elements 1202 based on the  
already filled letters in underscore elements 1202,  
10 disallowing arrangements that don't form coherent words.  
A DELETE input choice can also be moved about the display  
110, to delete a target that has been positioned into the  
underscore element 1202. This allows collective  
flexibility in the emerging answer 402.

15 Referring again to FIG. 12, the target board 404  
appears on the display 110 of the portable computing  
devices 100 of each of the plurality of users as  
implemented by the CIA running on each of those devices  
100. The users of each device 100 can selectively swipe  
20 at any of the letters (input choices 412), thereby  
generating the user intent vector with respect to that  
input choice 412. For example, if the user swipes at a  
letter F, that user will generate the user intent vector  
for the letter F input choice,  $UIV_F$ , that will get sent to  
25 the CCS 142. The CCS 142 will collect all the user  
intent vectors with respect to the letter F and create  
the group intent vector with respect to the letter F.  
The CCS 142 will then determine if the letter F will  
start moving based on the group intent vector. If so,  
30 the input choice copy 1200 of the letter F will start to  
move away from the stationary input choice F. This is  
done by the CCS 142 sending coordinates to the multiple



devices 100 indicating the updated location of the letter F input choice copy 1200 based on the group intent vector. Other users may see this moving input choice copy 1200 F and swipe to move the letter F input choice copy 1200 back towards the stationary letter F input choice location, or may swipe to aiming the letter F input choice copy 1200 towards one underscore element 1202 in the answer 402. Alternately, based on the user intent vectors the group may be in a stalemate and the letter F input choice copy 1200 will not move. Of course, while this is happening, other users are swiping at other letter input choice copies 1200, moving them in the same way, through interactions with the CCS 142. Thus, many letters are moving towards underscore elements 1202 in parallel, with many users reacting and responding, by swiping at the letter input choice copies 1200, either constructively or destructively, depending on their intent. The collective group intent will be represented as a motion of letter input choice copies 1200 on the display 110, the letter input choice copies 1200 finding their place in the awaiting underscore elements 1202 until the answer 402 forms. An intermediate state of this process can be seen with respect to FIGURE 12. As shown in FIG. 12, the answer is forming, possibly the word "OCTOBER", through the real-time collective group intent of the large number of users, all swiping at letter input choices 412 and collectively moving them.

In such embodiments, once the input choice copy 1200 substantially nears the awaiting underscore element 1202, it is deemed targeted by the CCS 142 and highlighted in the underscore element 1202. The target can then become

fixed in place, such that the target is no longer movable by the users. In some embodiments, the DELETE icon can be movable on the display 110 as well, and if moved to a selected target in the underscore element 1202, remove  
5 that target. The DELETE icon can be a red circle with a slash through it. Also, a SPACE icon can be collectively selected and positioned, making spaces between words in an emerging sentence.

It will be appreciated that the unique collaborative  
10 system disclosed herein, enabling users to convey user intent vectors that are summed or otherwise amalgamated in substantial real-time into the group intent vector, can be employed through software to enable other innovative collaborative systems, services, and  
15 functions. For example, if the collaboratively controlled pointer 406 is configured to leave a trail of pixels, a group of users is thereby enabled to collaboratively draw a picture, creating artwork which is produced not by any individual user but by the emergent  
20 collaborative consciousness. This would be artwork from a collective artificial intelligence. Such an embodiment could allow the users to collaboratively select from among a range of colors for the trail of pixels, collaboratively select among a "brush size" for the trail  
25 of pixels, and collaboratively select when the brush is leaving the trail and when it is not leaving the trail, thus allowing for empty space. In another embodiment, the users could collaboratively select and move a plurality of graphical elements around the display 110,  
30 arranging them into desired or prescribed configurations through the collaborative real-time closed-loop swiping process described with respect to letters above. As with

the letters, the plurality of graphical elements could be in motion at once, allowing for a parallel emergent display. In such embodiments, the scoring and weighting functions described previously can be employed.

5           The methods and systems described above address many deficiencies present in the current art, thereby enabling a group of users to come together online and take turns asking questions as individual users, then answer the questions together as a synchronous closed-loop system  
10 that evokes the groups collective intelligence.

          As expressed above, the synchronous nature of the system (i.e. the fact that the full group of users works together in real time) creates some unique challenges. One challenge is the fact that many users may wish to ask  
15 a question to the synchronous group at substantially the same time. For example, if one synchronous group is comprised of 30 users working in unison to answer questions, because all of said users are connected and contributing to the system at once, there may be a  
20 bottleneck when it comes time to asking a question, for a large percentage of the 30 users may wish to ask a question at the same time. This can create a frustrating situation for users wanting to ask questions to the collective intelligence of the group but are unable to,  
25 and/or have to wait a long time to ask.

          As previously described in FIGS. 1-3, in some embodiments users choose or are assigned a username when they log into the CCS 142, thus allowing software on the CCS 142 to keep track of individual users and assign each  
30 one a score based on their prior sessions. This also allows the CCS 142 to assign the right to ask a question to one or more users at any given moment in time. In some

embodiments, the CCS 142 is configured to moderate a turn-taking process in which each user of the full set of users is assigned the right to ask a question (or provide other data/input for collaborative action) in a sequence.

5 In some embodiments the sequence is ordered. In some embodiments the sequence is randomized. In some embodiments, each user must wait an assigned period of time after the prior question ends before he or she can ask a question by selecting an "ASK" icon displayed on

10 the display 110, the assigned period of time for each user being assigned differently for different users within the full user set. In this way, users with a short amount of time assigned to them have a first priority to ask a question as compared to users with a longer period

15 of time. In some embodiments the assignment of time periods is randomized by system thus creating a distribution of varying priority among the synchronous group of users.

In preferred embodiments, a group of users work

20 together in the synchronous system to answer questions that are routed to each of their computing devices 100 by the CCS 142 as previously described. In many such embodiments, the question originates from a single user, having been entered into their computing device 100 and

25 communicated to the CCS 142. The CCS 142 is configured to moderate the asking process by either (a) controlling which user(s) are enabled at any moment in time to ask questions, and/or (b) by selecting from among a plurality of received questions, which question will be selected as

30 the next question for the group, that question 400 being routed to each of the plurality of computing devices 100.

The target board 404, as displayed on the display 110 is configured to support the collaborative answering of questions by a synchronous group of users working as a real-time dynamic system.

5           In addition, the use of unique users names and/or other unique identifiers associated with each user in the synchronous system is used by the present invention to assign credits to each user such that users can earn credits, store credits, and spend credits under computer  
10 moderation of the CCS 142. To support this, the CCS 142 is configured to store in the memory (either the main memory 104 or the secondary memory 112), a credit value defining a current number of credits associated with each unique user, the credit value being incremented (i.e.  
15 credits are added to the credit value) when a user earns new credits and decremented when the user spends credits. In some embodiments the user can also lose credits for poor performance within the system. In some such  
20 embodiments the CCS 142 is configured to decrement credits from users who are deemed to have asked a "bad question" as will be described later in this document.

          In this way a "credit economy" is created where users earn redeemable points called credits when participating in the synchronous real-time answering of  
25 questions, and wherein users must expend such credits to enable the asking of questions to the synchronous group of users working as a collective intelligence. Users earn credits over time by actively participating in the collaborative answering of questions, thus accruing the  
30 right to ask future questions. In this way, users spend credits over time to ask questions. Further, the present invention includes systems and methods of establishing

the rate at which credits are earned by users for participating in answering of questions. Further, the present invention includes systems and methods of establishing the pricing (in credits) that is required to  
5 be expended for asking a question to a synchronous real-time collaborative group of users functioning as a collective intelligence.

In some embodiments the rate at which credits are earned by users for participating in the answering of a  
10 question is based, at least in part, upon the number of users collaborating in the answering as part of a real-time collective intelligence. In some embodiments, the number of credits earned by an individual users is a scaled function of the rate at which credits are earned,  
15 the scaled function being based at least in part upon a measure of performance of the user in one or more collaborative answers. In some such embodiments, the measure of performance is based at least in part on one of a time, an alignment, or a synchrony value. For  
20 example, in some embodiments the credit award is scaled higher in response to a shorter time period over which the group of users collaboratively answers a question, while the credit award is scaled lower in response to a longer time period over which the group of users  
25 collaboratively answers a question. In this way, the group is awarded higher credits for more rapidly answering a question, and lower credits for less rapidly answering a question. As described in related application, the synchrony value (also referred to as the  
30 synchronicity value) for a user is based on the amount of alignment of the user's input with overall group input. The more aligned the user input (for example, a user

intent vector as described in related applications) is with the group input (for example, a group intent vector as described in related applications), the more convergent that user is being at that moment therefore  
5 the user synchrony value is higher. The more opposed the user input is from the group input, the more divergent the user is being at the moment, therefore the user synchrony value is lower.

In some embodiments the pricing (i.e. the number of  
10 credits) required to be paid when asking one question to a collaborative intelligence comprised of a synchronous group of real-time users is based at least in part upon the number of users who are participating. In some  
15 embodiments the pricing is based at least in part upon a real-time auction method in which users bid to ask questions. In some embodiments a countdown auction method is employed to reduce the amount of input required of users to express a desired bid. These and other  
20 methods will be described in detail here, enabling a credit economy for earning and expending credits as a way to handle the bottleneck of question asking described above. Some such embodiments employ the novel use of an  
earn-to-spend ratio to ensure the credit economy runs smoothly.

25 As described above, the present invention comprises systems and methods for enabling groups of users to form in a synchronous real-time collaborative intelligence system wherein users take turns asking questions as  
individuals and wherein the group of users answer the  
30 question in real-time synchrony as a unified dynamic system (i.e. a collective swarm). To reduce problems associated with too many users wanting to ask questions

at substantially the same time, inventive enhancements have been developed. More specifically, methods and/or system have been developed, as described herein, to provide a flexible and universal method to assign the right to ask questions to particular users among the full group of collaborative participants, said participants engaged in real-time synchronous answering of questions. More specifically, the present invention comprises methods and/or systems that creates the "credit economy" where individual users among the set of participants earn redeemable points called credits when participating in the synchronous real-time answering of questions. In general, the CCS 142 is configured to track and store an account of credits (the credit value changing over time) associated with each unique user, selectively incrementing the credits in each user's account in response to a determination that the user earned credits when answering a question collaboratively. In many such embodiments, credits are awarded to a given user at least in part, based on a determination that the given user has performed collaboratively in a previous group answer. In some embodiments the CCS 142 software increments the credit amount of on particular user based upon a determination that the selected group result was previously input by the particular user as a suggestion.

In addition, the present invention is configured such that users must spend credits to enable the asking of questions to the synchronous group of users working as a collective intelligence. When a user asks a question, the cost of that question, in credits, is decremented from that user's credit value. Updated credit accounting is stored in the CCS 142 for the plurality of users. In



these ways, users earn credits over time by actively participating in the collaborative answering of questions, thereby accruing the right to ask future questions. In addition, users spend credits over time to ask questions. Further, the present invention includes systems and methods of establishing the rate at which credits are earned by users for participating in answering of questions. Further, the present invention includes systems and methods of establishing the pricing (in credits) that is required to be expended for asking a question to a synchronous real-time collaborative group of users functioning as a collective intelligence.

In some embodiments the rate at which credits are awarded to users for participating in the answering of a question is based, at least in part, upon the number of users collaborating in the answering as part of a real-time collective intelligence, as determined by the CCS 142. The rate at which credits are earned is referred to herein as the "earn rate". In some embodiments, the number of credits awarded to an individual user is a scaled function of the earn rate, the scaling being based at least in part upon a measure of performance of the user in one or more collaborative answers. In some such embodiments, the measure of performance is based at least in part on one of a time value associated with the answering of a question, an alignment value associated with the answering of a question, or a synchrony value associated with the answering of a question. In one embodiment the measure of performance is a performance value determined by the CCS 142 for each user. In some embodiments, the performance value for each user is based on how that user participated in the group collaboration,

i.e. in generating of the group result/answer. In one embodiment the performance value of each user is based at least in part upon a determined degree of collaboration of that user with the group of users.

5           In some embodiments the price at which credits must be paid by individual users to ask a question to the collaborative group of users is based, at least in part, upon the number of users participating (i.e. present) in the current synchronous system, as determined by the CCS  
10 142. The price at which credits must be paid to ask the question is referred to herein as the "query price". In some embodiments the query price (i.e. number credits required) required to be paid when asking a question to a collaborative intelligence comprised of a synchronous  
15 group of real-time users is based at least in part upon the number of users who are currently identified as being present within the synchronous group by the CCS server.

          In some embodiments the query price is based at least in part upon a real-time credit auction method in  
20 which users bid to ask questions, said bids being communicated to the CCS 142 which moderates the auction and determines the winner. The winner is generally determined as the highest bidder (i.e. the user who offered to pay the highest number of credits to ask a  
25 question to the synchronous group at the current time).

          In some embodiments a countdown auction method is employed to reduce the amount of input required of users to express a desired bid. In such embodiments, as will be described later, a credit value is presented to all  
30 users which gradually get lower and lower, as is displayed on each of their computing devices 100, until a first user clicks "ACCEPT" and thereby agrees to ask a

question at the then displayed price. In this way the credit value will quickly decrease, watched by a group of users at the same time, until at least one user is willing to pay that amount to ask a question. This finds  
5 an optimal price (the highest price someone is willing to pay) among the synchronous group of users. In some countdown credit auction embodiments the query cost steadily decreases until it reaches a floor query cost that defines the lower limit of possible query cost, at  
10 which point it does not decrease further. In some such embodiments, the floor query cost is a lower limit value of 0 credits. This countdown auction method is highly efficient and takes advantage of the uniquely synchronous assemblage of users.

15           These and other methods will be described in detail on the following pages, thereby enabling a credit economy for earning and expending credits as a way to handle the bottleneck of question asking described above.

          In some embodiments of the present invention,  
20 credits are awarded to users by the moderating software of the CCS 142 in response to said users participating in the answering of questions such that the more users who are synchronously participating in the real-time closed-loop answering process (i.e. the bigger the swarm of  
25 users), the more credits each participant earns (i.e. is awarded) for taking part in each answer. This methodology for determining a current "earn rate" based on the number of users has been invented because larger synchronous groups of users will have longer wait-times  
30 to ask questions because there are more users vying to ask. This creates a disincentive for users to participate in larger group as compared to smaller groups. To account

for the disincentive associated with the longer wait times, users who participate in answering as part of a larger synchronous group are awarded more credits for answering than users who are participating in smaller  
5 synchronous groups.

In some embodiments, the size of the group (in number of users) is used by the CCS 142 to define a max credit award which is a maximum number of credits that can be awarded to an individual user for participation in  
10 a real-time closed-loop synchronous session in that group that resulted in an answer. An earn rate is the max credit award expressed as a function of answered questions, for example if the max credit award is 100 credits, the earn rate is 100 credits per answered  
15 question.

In some such embodiments the CCS 142 is configured to award credits to each individual user by scaling the max credit award based on how collaborative that individual user was when answering as a member of the  
20 synchronous real-time collective. The more collaborative a user was answering a question (as indicated by a metric such as user synchrony) the more credits that user earns for participation. Thus, if a user is determined by the moderating software to have been highly collaborative in  
25 contributing to the final answer, that user will earn a credit amount equal to the max credit award or close to the max credit award. Conversely a user who is determined by the moderating software to be less collaborative when answering a question will earn a  
30 smaller percentage of the max credit award or no credits will be awarded. In some embodiments the credit award is based at least in part upon the elapsed time taken by the

group to answer the question. In some such embodiments, the credit award is scaled higher in response to a shorter time period over which the group of users collaboratively answers a question, while the credit  
5 award is scaled lower in response to a longer time period over which the group of users collaboratively answers a question. In this way, the group is awarded higher credits for more rapidly answering a question, and lower credits for less rapidly answering a question.

10 Referring next to FIG. 13, a flowchart of a method for determining the query price is shown. Shown are a determine max credit award step 1300, a determine ask rate step 1302, a determine query price step 1304, and an adjust query price step 1306.

15 As implemented by the current systems and methods, earned credits are stored in user indexed accounts stored on the CCS 142, or in some embodiment stored remotely but accessible to the CCS 142. These credits have value because users must spend credits to ask a question to the  
20 collective group. In preferred embodiments, the query price associated with asking a question to a synchronous group is defined by the moderating software such that the larger the size of the group, the more expensive it is to ask (i.e. the higher the query price). This inventive  
25 method works well for users because a large group is likely to have many users who want to ask questions at a given moment in time, thus creating a large amount of competition to ask. Increased competition creates frustration for users who want to ask questions. By  
30 increasing the cost (the query price) of asking a question to a large synchronous group, the system reduces the number of users willing ask a question at a given

moment in time and thus reduces the competition bottleneck for asking questions.

Furthermore, users perceive the modified query price as fair because large collective group working as a  
5 synchronous system has the most brainpower to contribute, thus it feels appropriate to spend more credits to ask a question to that large group as compared to the credits that must be spent for asking to a smaller group. In this way the present invention creates the "credit  
10 economy" that feels inherently fair to users, and thus earns user support. This inventive method also reduces the chance that users will ask deliberately destructive questions as "trolls" because the users asking destructive questions would be wasting their credits. In  
15 this way, the credit economy increases the quality of asked questions, reduces competition among users, and thus increases the overall satisfaction for all users.

One goal of the credit economy is to address the fact that participants in synchronous real-time question-  
20 and-answer systems often can't ask questions as often as they want, especially when the synchronous group has a large number of users. If a group has  $N$  users, and all  $N$  always want to ask a question at any open opportunity (i.e. during the periods between questions), each user  
25 can only ask questions at  $1/N$ th the rate they'd like to ask. To address this, the query price method of FIG. 13 may be used.

In the first determine max credit award step 1300, the max credit award for the group having  $N$  number of  
30 users is determined. The max credit award may be determined for the particular instant group, or the max

credit award may be the same value across the entire collaborative system.

In the next determine ask rate step 1302, the CCS 142 determines an ask rate, where the ask rate is defined as the approximate percentage of users wanting to ask a question at a moment in time. For example, at a moment in time for a particular group, approximately 10% of the users of the group want to ask a question, therefore the ask rate is 10% (or 0.10).

Proceeding to the next determine query price step 1304, the query price is determined by multiplying the max credit award by the ask rate and the total number of currently participating users  $N$ . The query price can be then displayed for all participating users of the group, or the process can proceed to the optional adjust query price step 1306, where the query price is adjusted for some or all individual users, as described further below.

An earn-to-spend value is defined as a value that relates the ratio between the query price for an individual asking a question and the award to each participant for collectively answering the question. The earn-to-spend ratio can be set, in the CCS 142 software, to a number that is approximately the fraction of users who want to ask a question at any moment in time (the ask rate) multiplied by the number of users in the group. For example, if it's determined that at any moment in time, on average, approximately 10% of the participating users in a synchronous group want to ask questions (i.e. the ask rate is 10% or 0.10), and if that synchronous group has 200 users, the earn-to-spend ratio can be set to  $10\% \times 200 = 20$ . This means that the cost of asking questions will be moderated by the CCS 142 to be approximately 20

times the max credit award for a user's participation the collaborative responses. As a result, each user will need to participate in answering approximately 20 questions to earn enough to ask one question. This establishes a  
5 credit economy that is well balanced, awarding credits to participating users at a rate that approximately matches the credits needed for users to ask questions at a rate that can be supported. This eliminates the bottleneck for asking, having users not feel frustrated about  
10 waiting their turn, but instead feel motivated to answer questions and earn enough to ask a question. It's a highly effectively way of fairly managing user expectations and driving participation.

In another embodiment, if the max credit award  
15 for participating in the real-time synchronous answering of a question is itself defined in software as function of the participating number of users in the synchronous group, then the cost to ask a question can be defined as a function of the number of participants squared. This  
20 works well because if everyone in the group wants to ask a question, the cost to ask needs to be a factor of the number of participants higher than the credits to answer.

In one example, a user joins a synchronous group with 100 active (participating) users. The average ask  
25 rate for users this group may be 12%, meaning that at a typical moment 12% of the users wish to ask a question. From this we can compute that at any moment in time, on average, there will be 12 users who want to ask. Therefore, the earn-to-spend ratio is  $12\% * 100 \text{ users} = 12$ .

30 For the max credit award set to a value of 100 credits (i.e. the earn rate is 100 credits per answered



question), the query price is the earn-to-spend ratio \* the max credit award = 12 \* 100 credits = 1200 credits.

This means each user must participate in approximately 12 answers, at the earn rate of approximately 100 credits per answer, in order to earn the 1200 credits needed to ask one question. If each user can only ask questions at a rate of one ask per 12 answers, and if in general 12 users want to ask at any given time, and if those 12 users must answer 12 questions between asking, the economy is nicely balanced, achieving a natural match between ask rates and answer rates. Of course, average rates over time are considered, with fluctuations around the averages expected.

Also, in many embodiments, users do not earn the max credit award for participation but instead earn a scaled value of the max credits award, the scaling being defined as a function of user performance. In this way, high performing (i.e. highly collaborative users) will earn credits at a rate that's higher, and low performing users (i.e. obstructive users) will earn credits at a rate that's lower, thereby rewarding collaborative users with the ability to ask questions at a higher rate and punishing obstructive users with the ability to ask questions at a lower rate.

In some embodiments, credit bonuses are also awarded by the CCS 142 to users who contribute in extra ways. For example, users who provide suggested which are collaboratively selected by the synchronous group as the final answer can be awarded with a credit bonus. This encourages users to contribute skilled suggestions.

In some embodiments, credit demerits (i.e. credits are subtracted from the user's credit value) are also

assigned by the CCS 142 to users who are especially obstructive. For example, users who ask questions that are deemed by the synchronous group to be "bad questions" are assigned a credit demerit, resulting in credits being  
5 subtracted from the user's credit value. This discourages users from asking questions that are destructive or obstructive to the group's activities (as deemed by the collective swarm). In some embodiments credits are decremented from the credit amount of one  
10 user who provides the question collaboratively responded to by the group, wherein the group returns a collaborative result indicating that the question was not worthy of being answered.

In some embodiments, credit demerits are assigned by  
15 the CCS 142 to all participants for an answer determined by the CCS 142 to be an unskilled collective response by the group. For example, if the full group, working as a collective intelligence, fails to reach an answer within the allotted time and instead yields a "BRAIN FREEZE"  
20 assessment, all participants in that synchronous group can be assigned a credit demerit by the CCS 142. This gives the full group a collective incentive to find common ground and reach answers on posed questions. We can think of this as imparting a "prisoner's dilemma"  
25 upon the group for each participant needs to weight the positive effect of getting the pointer 406 to their highest choice answer 412 with the negative effect of having no answer being reached and all users getting a credit demerit. This helps incentivize the synchronous  
30 group to find the right balance between personal opinions and group compromise as they collaboratively control the

puck as a real-time closed-loop system, converging upon answers.

Referring next to FIG. 14, a flowchart for a countdown auction method is shown in one embodiment of the present invention. Shown are an initial set query price step 1400, a start current time period step 1402, an asked question decision point 1404, a charge user decision point 1406, a time period ended decision point 1408, and a lower query price 1410.

In the first initial set query price step 1400, the CCS 142 sets an initial current query price equal to the max query price, i.e. the maximum credit value a user would have to pay in order to ask a question. The CCS 142 sends the initial current query price to the plurality of computing devices 100 and the initial current query price is displayed to the users. The method then proceeds to the start current time period step 1402.

During the start current time period step 1402, the CCS starts a current time period during which the current query price remains the same. The process then proceeds to the asked question decision point 1404. If a user inputs (asks) a question after the start of the current time period, the method proceeds to the charge user decision point 1406. In the charge user decision point 1406, the user is debited (charged) an amount of credits equal to the current query price, and the question input by the user is sent to the CCS 142 and used as the question for the next collaborative session.

If no user has input a question, the process proceeds to the time period ended decision point 1408. In the time period ended decision point 1408, if the current time period has not yet ended, the method returns to the

asked question decision point 1404, and if no user has input a question, repeats the loop. If the current time period has ended, the CCS 142 lowers the current query price and the new current query price is sent to the  
5 plurality of computing devices 100 and displayed so that all users can see the revised query price. The process then returns to the start current time period step 1402, and a new time period is started.

While the flowchart of FIG. 14 describes the method  
10 in which the CCS 142 performs the steps of decrementing the query price, other embodiments enable the local computing device 100 of the each user to perform the steps of decrementing the query price. In such  
15 embodiments, the CCS 142 provides supervisory control over the process, defining the initial query price, and optionally defining parameters that influence the rate and floor value by which the query price will be  
20 decremented by each computing device 100. This distributes the computing load and reduces communication burden. In some such embodiments, a floor query price is defined such that query price steadily decreases until the query price reaches a lower limit established by the floor query price, at which point it does not decrease  
25 further. In some such embodiments, the floor query price is a lower limit value of zero (0) credits. In some such embodiments, the word "free" is displayed by the local computer instead of the display of the "0" credits value. In some embodiments, the initial query price is set based  
at least in part on the number of users in the group.

30 Referring again to FIG. 14, while the previous method of FIG. 13 for establishing the cost of asking questions works much of the time, the method does not

account for the fact that at some moments, an unusually large percentage of users might want to ask a question, while at other moments, very few users might want to ask a question. More specifically, the above method handles  
5 the average situations well but does not account for the fact that the number of users who actually want to ask a question at a particular moment in time (the ask rate) may vary from a small percentage of the full group to a very large percentage of the full group. The variance  
10 could be random, or it could be situation related. For example, if the synchronous group of users is engaged in a heated debate on a hot topic, a very large percentage of users may want to ask questions at the same time. Thus an enhanced method is needed that handles the case where  
15 far fewer than the average number of users want to ask questions, or far greater than the average number of users want to ask questions. The method of FIG. 14, the countdown auction method solves these problems.

The countdown auction method is enabled in the CCS  
20 142 software such that the cost to ask a question is a variable number of credits that starts at a high value and decreases over time until one of the plurality of participants chooses to ask a question. For example, at the moment when a prior question is answered and system  
25 is thus ready to take on a new question from one of the plurality of users, the initial current query price equal to the max query price appears on the display 110 of the computing devices 100 of the plurality of users (the set query price step 1400). The current query price value  
30 then gradually decreases over time, thus gradually lowering the cost to ask a question at the present time. This create a unique situation that leverages the

synchrony of the present system, for all users know that if they wait longer the cost to ask will go down. At the same time, all users know that if they wait too long, one of the other users might agree to the present cost and thus take the current opportunity to ask a question for themselves. Thus it's a competition structured as a "game of chicken" to find which user is willing to agree first to the cost of asking, and thus ask the next question to the group. The method inherently finds the pressure point at which the aversion to spending credits matches the desire to be the user who gets to ask the next question.

Referring next to FIG. 15, an exemplary countdown auction display interface 1500 is shown. Shown are a group name 1502, the target board 404, the plurality of input choices 412, the pointer 406, a communication menu 1504, a board selection drop-down menu 1506, a physics selection drop-down menu 1508, a chat window 1510, a chat input box 1512, a current member list 1514, a statistics display 1516, a prompt bar 1520, a countdown credit value 1518, a prompt bar 1520, and an ask button 1522.

The exemplary countdown auction display interface 1500 is modeled on the display interfaces previously disclosed in related patent application 14/859,035. As shown in FIG. 15 above, the countdown credit value 1518 generally appears proximal to the ask button 1522 displayed on the display 110 of the computing device 100 of each user, the ask button 1522 proximal to the prompt bar 1520 where users can enter their question with a keyboard and/or by voice. A similar screen appears to all users in the synchronous group when the CCS 142 is ready to receive a new question. The countdown credit value 1518 is displayed to all users. To agree to ask a

question, any one of the plurality of synchronous users can enter a question into the prompt bar 1520 and then press the ask button 1522, thereby agreeing to be charged the number of credits that currently appears in the  
5 countdown credit value 1518. This countdown auction method allows for a simple user interface wherein the credit selection process is one click, and yet the group collectively finds the price the market will bear for currently asking a question. If there happens to be high  
10 competition for asking at the present moment, the cost that a user will agree to is likely high. If there happens to be low competition for asking a question, the cost that user will agree to is low.

In other embodiments the countdown credit auction  
15 can be replaced by a more traditional bidding auction in which users simply bid a number of credits for asking the next question. This works but requires more clicks and thus greater effort on the part of users. It also takes away some of the urgency. Urgency is desirable because  
20 it keeps users asking questions with energy.

Thus in many embodiments the system is configured to avoid a laborious bidding process using the countdown method as follows: When the system is ready to allow users to ask new questions, the ask button 1522 appears  
25 along with the indication of the initial current query price as indicated by the countdown credit value 1518 (typically the max query price) to ask a question to that synchronous group. The cost then drops steadily over time, to lower and lower credit levels, until a user is  
30 willing to click the ask button 1522. If there are not users eager to ask, the cost will continue to drop until the current query price (and the displayed countdown

credit value 1518) reaches a minimum value (possibly 0, making the ask free at the present time).

This countdown methodology, combined with the fact that the maximum cost to ask a question can be defined in software as a function of the number of participants in the group, allows the system to converge upon, approximately, the highest acceptable credit cost for each question asked.

It will be appreciated that the unique collaborative system disclosed herein, enabling users to convey user intent vectors that are summed or otherwise amalgamated in substantial real-time into the group intent vector, can be employed through software to enable other innovative collaborative systems, services, and functions. For example, if the collaboratively controlled pointer 406 is configured to leave a trail of pixels, a group of users is thereby enabled to collaboratively draw a picture, creating artwork which is produced not by any individual user but by the emergent collaborative consciousness. This would be artwork from a collective artificial intelligence. Such an embodiment could allow the users to collaboratively select from among a range of colors for the trail of pixels, collaboratively select among a "brush size" for the trail of pixels, and collaboratively select when the brush is leaving the trail and when it is not leaving the trail, thus allowing for empty space. In another embodiment, the users could collaboratively select and move a plurality of graphical elements around the display, arranging them into desired or prescribed configurations through the collaborative real-time closed-loop swiping process described with respect to letters above. As with



the letters, the plurality of graphical elements could be in motion at once, allowing for a parallel emergent display. In such embodiments, the scoring and weighting functions described previously can be employed.

5           While many embodiments are described herein, it is appreciated that this invention can have a range of variations that practice the same basic methods and achieve the novel collaborative capabilities that have been disclosed above. Many of the functional units  
10 described in this specification have been labeled as modules, in order to more particularly emphasize their implementation independence. For example, a module may be implemented as a hardware circuit comprising custom VLSI  
15 such as logic chips, transistors, or other discrete components. A module may also be implemented in programmable hardware devices such as field programmable gate arrays, programmable array logic, programmable logic devices or the like.

20           Modules may also be implemented in software for execution by various types of processors. An identified module of executable code may, for instance, comprise one or more physical or logical blocks of computer  
25 instructions that may, for instance, be organized as an object, procedure, or function. Nevertheless, the executables of an identified module need not be physically located together, but may comprise disparate instructions stored in different locations which, when  
30 joined logically together, comprise the module and achieve the stated purpose for the module.

          Indeed, a module of executable code could be a single instruction, or many instructions, and may even be

distributed over several different code segments, among  
different programs, and across several memory devices.  
Similarly, operational data may be identified and  
illustrated herein within modules, and may be embodied in  
5 any suitable form and organized within any suitable type  
of data structure. The operational data may be collected  
as a single data set, or may be distributed over  
different locations including over different storage  
devices, and may exist, at least partially, merely as  
10 electronic signals on a system or network.

While the invention herein disclosed has been  
described by means of specific embodiments, examples and  
applications thereof, numerous modifications and  
variations could be made thereto by those skilled in the  
15 art without departing from the scope of the invention set  
forth in the claims.

The following numbered statements set out particular combinations of features which are considered relevant to particular embodiments of the present disclosure:

1. A collaborative intelligence system for determining a group result in real-time from a group of users presented with a group question, comprising:

a plurality of computing devices, at least one user associated with each computing device, each computing device comprising a communications infrastructure coupled to each of a processor, a memory, a timing circuit, a display interface coupled to a display and configured to receive input from at least one user;

a collaborative approval application stored on each memory and configured to run on each processor to:

convey to the user, using the display interface, the group question ;

receive, repeatedly in real-time, user input; send, repeatedly in real-time, a representation of the user input to a collaboration server;

receive, repeatedly in real-time, the group result from the collaboration server, the group result based at least in part on the plurality of representations of user inputs; and

present, repeatedly in real-time, a graphical indication of the group result to the user using the display interface;

the collaboration server in networked communication with the plurality of computing devices, the collaboration server including a server processor and a server memory, the server processor configured to run a collaboration application stored on the server memory, the collaboration application configured to perform the steps of:

assign and store a unique identity for each user ;

store a credit amount for each user, wherein the credit amount may be changed based at least in part upon that user's participation in at least one of asking the group question and providing user input in response to the group question;

send the group question to the plurality of computing devices;

receive, repeatedly in real-time, the representation of the user input from each of the plurality of computing devices;

responsively determine, repeatedly in realtime, the group result from the user input; and

send, repeatedly in real-time, the group result to the plurality of computing devices, whereby a closed-loop system is formed between the

collaboration server and each collaborative intent applications ;

determine a final group result; and

send the final group result to the plurality of computing devices.

2. The collaborative intelligence system for determining the group result in real-time from the group of users of statement 1, the collaboration application further configured to decrement a query price from the credit amount of a first user of the group of users in response to receiving the group question from a first computing device associated with the first user.

3. The collaborative intelligence system for

determining the group result in real-time from the group of users of statement 2, the collaboration application further configured to send the group question received from the computing device associated with the first user to the plurality of computing devices, the decrementing of the query price from the credit amount of the first user performed in response to the receiving of the group question from the first computing device followed by the sending of the group question by the collaboration application .

4. The collaborative intelligence system for

determining the group result in real-time from the group of users of statement 2, wherein the query price is based at least in part upon a number of users who are

participating in the determination of the group result.

5. The collaborative intelligence system for

determining the group result in real-time from the group of users of statement 2, wherein the query price decreases over a period of time, thereby enabling a real-time auction among the users to determine a current price of asking a question.

6. The collaborative intelligence system for

determining the group result in real-time from the group of users of statement 1, the collaboration server further configured to award credits to each of a plurality of users based at least in part upon determining that each of the plurality of users has participated in

collaborative generation of the group result.

7. The collaborative intelligence system for

determining the group result in real-time from the group of users of statement 6, wherein a number of credits awarded is based at least in part upon a number of users who are participating in the determination of the group result.

8. The collaborative intelligence system for

determining the group result in real-time from the group of users of statement 7, wherein a larger number of users corresponds to a larger credit award.

9. The collaborative intelligence system for

determining the group result in real-time from the group of users of statement 6, wherein a number of credits awarded is based at least in part upon a length of time used by the group of users to produce the group result .

10. The collaborative intelligence system for

determining the group result in real-time from the group of users of statement 9, wherein a shorter length of time corresponds to a larger credit award.

11. The collaborative intelligence system for

determining the group result in real-time from the group of users of statement 1, the collaboration server further configured to award credits at least one user based at least in part upon determining a performance value for the at least one user, said performance value based on how that user participated in the generating of the group result .

12. The collaborative intelligence system for

determining the group result in real-time from the group of users of statement 11, wherein the performance value for the at least one user is based at least in part upon a determined degree of collaboration of that user with the group of users.

13. The collaborative intelligence system for

determining the group result in real-time from the group of users of statement 2, the collaboration application further configured to decrement a credit amount of a second user in response to an answer suggestion input by the second user.

14. The collaborative intelligence system for

determining the group result in real-time from the group of users of statement 2, the collaboration application further configured to increment the credit amount of a second user based upon a determination that the final group result was previously input by the second user as a suggestion.

15. The collaborative intelligence system for

determining the group result in real-time from the group of users of statement 1, the collaboration application further configured to decrement credits from the credit amount of a first user if the first user asked the group question and the group result indicates a group decision indicating that the group question was not worthy of being answered.

16. The collaborative intelligence system for

determining the group result in real-time from the group of users of statement 15 wherein the group question is not worthy of being answered when the group result is a selection of a response labeled "bad question".

17. The collaborative intelligence system for

determining the group result in real-time from the group of users of statement 15, wherein the number of credits decremented for the asking of the group question unworthy of being answered is based at least in part upon a number of users who are participating in the determination of the group result .

18. A method for enabling a credit economy for a collaborative intelligence system for determining a group result in real-time from a group of users, including a collaboration server including a server processor and a server memory, the server processor configured to run a collaboration application stored on the server memory, the collaborative intelligence system further including a plurality of computing devices, at least one user associated with each computing device, each user

associated with a credit value stored by the

collaboration server, each computing device comprising a communications infrastructure coupled to each of a device processor, a device memory, a timing circuit, a display interface coupled to a display and configured to receive input from at least one user, and a collaborative approval application stored on each device memory and configured to run on each device processor, wherein the collaboration server is in networked communication with the plurality of computing devices, the method comprising the steps of :

determining, by the collaboration server, of a query price, said query price based at least in part upon a number of users in the group of users;

receiving, by the collaboration server, of a group question from a first user;

enabling, by the collaboration server in response to receiving of the group question, the plurality of users to collaboratively answer the group question by

collaboratively generating a group result;

decrementing the query price from a credit amount associated with the first user based upon a determination that the first user asked the group question that was collaboratively answered by a participating portion of the group of users; determining, by the collaboration server, a credit award value, the credit award value based at least in part upon the number of users in the group of users; and incrementing, by the collaboration server, of the credit amount associated with each of the participating portion of the group of users, the incrementing of the credit amount based at least in part upon the credit award value associated with the group question.

19. The method for enabling the credit economy for the collaborative intelligence system of statement 18, wherein a larger number of users in the group corresponds to a larger credit award value.

20. The method for enabling the credit economy for the collaborative intelligence system of statement 18, wherein a larger number of users in the group corresponds to a higher query price

21. The method for enabling the credit economy for the collaborative intelligence system of statement 18, wherein the credit award value is also based at least in part on at least one of a time value and an alignment value associated with the group of users.

22. The method for enabling the credit economy for the collaborative intelligence system of statement 18, wherein a ratio of the query price to the credit award value is set by the collaboration application based at least in part upon a predicted percentage of users currently desiring to ask a question.

23. A countdown auction method for determining a query price for a collaborative intelligence system for determining a group result in real-time from a group of users, including a collaboration server including a server processor and a server memory, the server

processor configured to run a collaboration application stored on the server memory, the collaborative

intelligence system further including a plurality of computing devices, at least one user associated with each computing device, each user associated with a credit value stored by the collaboration server, each computing device comprising a communications infrastructure coupled to each of a device processor, a device memory, a timing circuit, a display interface coupled to a display and configured to receive input from at least one user, and a collaborative approval application stored on each device memory and configured to run on each device processor, wherein the collaboration server is in networked

communication with the plurality of computing devices, the method comprising the steps of:

setting an initial query price on each of the plurality of computing devices, the setting coordinated by the collaboration application;

displaying, by each computing device, of a current query price equal to an initial query price on the display;

repeatedly determining, by the collaboration server, whether one user has input a question via one of the plurality of computing devices;

during a time period when no user has input the question, repeatedly decrementing the current query price as displayed by each of the plurality of computing devices, the current query price representing a current cost of asking a question for each user associated with each computing device, thereby enabling a real-time credit auction among the plurality of users; and

upon determining that a first user of the group of users has input the question, decrementing a credit amount associated with the first user by the current query price displayed to the first user.

24. The countdown auction method of statement 23, wherein the repeatedly decrementing of the current query price ceases when the current query price reaches a lower limit .
25. The countdown auction method of statement 24, wherein the lower limit is zero credits.
26. The countdown auction method of statement 23, wherein the initial query price is set based at least in part upon a number of users in the group of users .
27. The countdown auction method of statement 23 wherein each user of the group of users is awarded credits for participating in a collaborative answering of the question asked by the first user.
28. The countdown auction method of statement 27 wherein number of awarded credits for each user is based at L in part upon a number of users in the group of users.



## Claims

1. A real-time collaborative intelligence system comprising:

a plurality of computing devices each comprising a communications infrastructure coupled to each of a processor, a memory, a timing circuit, and a user interface coupled to a display and configured to receive input from a user;

a collaborative intent application stored on each memory and configured to run on each processor, to:

display a question and a set of spatially arranged answer options for a collaborative intelligence session, a collaboratively controlled graphical pointer having a movable location in relation to the set of spatially arranged answer options,

receive, repeatedly in real-time during the session, a user intent through the user interface, the user intent having a direction value in relation to the set of spatially arranged answer options,

send, repeatedly in real-time during the session, an updated user intent to a collaboration server,

receive, repeatedly in real-time during the session, a coordinate location in relation to the set of spatially arranged answer options, and

update, repeatedly in real-time during the session, the location of the collaboratively controlled graphical pointer in relation to the set of spatially arranged answer options using the received coordinate location; and

the collaboration server in networked communication with the plurality of computing devices, the collaboration server including a processor and a memory, the processor configured to run a collaboration mediation application stored on the memory, the collaboration mediation application configured to:

send the question and the set of spatially arranged answer options for the collaborative intelligence session to each of the plurality of computing devices,

receive, repeatedly in real-time during the session, the user intent from each of the plurality of computing devices,

responsively determine, repeatedly in real-time during the session, a group intent from the plurality of received user intents

responsively determine, repeatedly in real-time during the session, an updated coordinate location for the collaboratively controlled graphical pointer based at least in part upon the group intent, and

send, repeatedly in real-time during the session, the coordinate location to the plurality of computing devices;

whereby the coordinate location is updated repeatedly by the collaboration server, whereby a closed-loop system is formed between the collaboration server and each collaborative intent application.

2. The real-time collaborative intelligence system of claim 1, wherein determining the group intent is computed using a weighted average of user intents, wherein the weighting for at least one user intent is based at least in part upon a user score associated with the user generating the at least one user intent.

3. The real-time collaborative intelligence system of claim 2 wherein the user score associated with the user is based on that user's performance in at least one prior collaborative intelligence session.

4. The real-time collaborative intelligence system of claim 2 wherein the user score associated with the user is based on that user's accuracy in at least one prior collaborative intelligence session.

5. The real-time collaborative intelligence system of claim 1, wherein the question asks which team will win a sporting event, and the set of answer options includes the names of a plurality of sports teams.

6. The real-time collaborative intelligence system of claim 1, wherein the collaborative intent application is further configured to display a graphical indication of the user intent on the display

7. The real-time collaborative intelligence system of claim 6, wherein the graphical indication of the user intent is an updated location of a user controlled graphical pointer, separate from the collaboratively controlled graphical pointer, on the display.

8. The real-time collaborative intelligence system of claim 7, wherein the direction of the user intent is derived at least in part based on relative locations of the user controlled graphical pointer and the collaboratively controlled graphical pointer.

9. The real-time collaborative intelligence system of claim 1, each of the plurality of computing devices further including a tilt sensor coupled to the processor, wherein the user interface is updated using the tilt sensor, and the collaborative intent application is further configured to receive a user input using the tilt sensor and compute the user intent based at least in part upon the tilt value.

10. The real-time collaborative control system of claim 1, wherein the user input is received using a touchscreen display.

11. The real-time collaborative intelligence system of claim 10, wherein the user intent is derived based upon a swipe gesture imparted by a user upon the touch screen, the direction of the user intent based upon a direction of the swipe gesture.

12. The real-time collaborative intelligence system of claim 11, wherein the user intent has a magnitude and the magnitude of the user intent is derived at least in part based upon a velocity of the swipe gesture imparted by the user upon the touchscreen.

13. The real-time collaborative intelligence system of claim 1, wherein the collaboration server is further configured to:

determine when an answer option is selected from the set of spatially arranged answer options based at least in part upon a proximity between the location of the collaboratively controlled graphical pointer and a spatial location of the selected answer option; and

send, upon determining that the answer option is selected, an indication of the selected answer option to the plurality of computing devices.

14. The real-time collaborative intelligence system of claim 13, wherein the determining that the answer option is selected is based at least in part upon whether the collaboratively controlled graphical pointer is within a proximity of the selected answer option for more than a threshold amount of time.

15. The real-time collaborative intelligence system of claim 8, wherein the user intent has a magnitude based at least in part on a distance between the real-time location of the user controlled graphical pointer on the display and the real-time location of the collaboratively controlled graphical pointer on the display.

Amendments to the claims are filed as follows:

### Claims

1. A real-time collaborative intelligence system comprising:

a plurality of computing devices each comprising a communications infrastructure coupled to each of a processor, a memory, a timing circuit, and a user interface coupled to a display and configured to receive input from a user;

a collaborative intent application stored on each memory and configured to run on each processor, wherein each user is associated with one of the plurality of computing devices, to:

display a question and a set of spatially arranged answer options for a collaborative intelligence session, a collaboratively controlled graphical pointer having a movable location in relation to the set of spatially arranged answer options,

receive, repeatedly in real-time during the session, a user intent through the user interface, the user intent having a direction value in relation to the set of spatially arranged answer options,

send, repeatedly in real-time during the session, an updated user intent to a collaboration server,

receive, repeatedly in real-time during the session, a coordinate location in relation to the set of spatially arranged answer options, and

update, repeatedly in real-time during the session, the location of the collaboratively controlled graphical pointer in relation to the set of spatially arranged answer options using the received coordinate location; and

the collaboration server in networked communication with the plurality of computing devices, the collaboration server including a processor and a memory, the processor configured to run a collaboration mediation application stored on the memory, the collaboration mediation application configured to:

send the question and the set of spatially arranged answer options for the collaborative intelligence session to each of the plurality of computing devices,

receive, repeatedly in real-time during the session, the user intent from each of the plurality of computing devices,

responsively determine, repeatedly in real-time during the session, a group intent from the plurality of received user intents,

14 04 22

responsively determine, repeatedly in real-time during the session, an updated coordinate location for the collaboratively controlled graphical pointer based at least in part upon the group intent, and

send, repeatedly in real-time during the session, the coordinate location to the plurality of computing devices;

whereby the coordinate location is updated repeatedly by the collaboration server, whereby a closed-loop system is formed between the collaboration server and each collaborative intent application; and

award and store a number of redeemable credits for each user providing user input to the closed-loop system, wherein the number of redeemable credits awarded to each user providing user input is determined at least in part on a number of users providing input to the closed-loop system.

2. The real-time collaborative intelligence system of claim 1, wherein determining the group intent is computed using a weighted average of user intents, wherein the weighting for at least one user intent is based at least in part upon a user score associated with the user generating the at least one user intent.

3. The real-time collaborative intelligence system of claim 2 wherein the user score associated with the user is based on that user's performance in at least one prior collaborative intelligence session.

4. The real-time collaborative intelligence system of claim 2 wherein the user score associated with the user is based on that user's accuracy in at least one prior collaborative intelligence session.

5. The real-time collaborative intelligence system of claim 1, wherein the question asks which team will win a sporting event, and the set of answer options includes the names of a plurality of sports teams.

6. The real-time collaborative intelligence system of claim 1, wherein the collaborative intent application is further configured to display a graphical indication of the user intent on the display.

14 04 22

7. The real-time collaborative intelligence system of claim 6, wherein the graphical indication of the user intent is an updated location of a user controlled graphical pointer, separate from the collaboratively controlled graphical pointer, on the display.

8. The real-time collaborative intelligence system of claim 7, wherein the direction of the user intent is derived at least in part based on relative locations of the user controlled graphical pointer and the collaboratively controlled graphical pointer.

9. The real-time collaborative intelligence system of claim 1, each of the plurality of computing devices further including a tilt sensor coupled to the processor, wherein the user interface is updated using the tilt sensor, and the collaborative intent application is further configured to receive a user input using the tilt sensor and compute the user intent based at least in part upon the tilt value.

10. The real-time collaborative control system of claim 1, wherein the user input is received using a touchscreen display.

11. The real-time collaborative intelligence system of claim 10, wherein the user intent is derived based upon a swipe gesture imparted by a user upon the touch screen, the direction of the user intent based upon a direction of the swipe gesture.

12. The real-time collaborative intelligence system of claim 11, wherein the user intent has a magnitude and the magnitude of the user intent is derived at least in part based upon a velocity of the swipe gesture imparted by the user upon the touchscreen.

13. The real-time collaborative intelligence system of claim 1, wherein the collaboration server is further configured to:

determine when an answer option is selected from the set of spatially arranged answer options based at least in part upon a proximity between the location of the collaboratively controlled graphical pointer and a spatial location of the selected answer option; and

send, upon determining that the answer option is selected, an indication of the selected

14 04 22

answer option to the plurality of computing devices.

14. The real-time collaborative intelligence system of claim 13, wherein the determining that the answer option is selected is based at least in part upon whether the collaboratively controlled graphical pointer is within a proximity of the selected answer option for more than a threshold amount of time.

15. The real-time collaborative intelligence system of claim 8, wherein the user intent has a magnitude based at least in part on a distance between the real-time location of the user controlled graphical pointer on the display and the real-time location of the collaboratively controlled graphical pointer on the display.

16. The real-time collaborative intelligence system of claim 1, wherein awarded credits are configured to be later redeemable by that user for a right to ask a future question to be displayed on each of the plurality of computing devices.

17. The real-time collaborative intelligence system of claim 16, wherein a number of credits required for the right to determine the future question is based at least in part on the number of users providing input to the closed-loop system.

14 04 22





**Application No:** GB2202778.3

**Examiner:** Mr David Maskery

**Claims searched:** n/a

**Date of search:** 4 March 2022

**Patents Act 1977: Search Report under Section 17**

**Documents considered to be relevant:**

Category	Relevant to claims	Identity of document and passage or figure of particular relevance
X,E	all	EP 3123442 A (UNANIMOUS A.I. INC) See pages 6 to 56 and figs.
X,E	all	EP 3210386 A (UNANIMOUS A.I. INC) See pages 8 to 28.
X	1 at least	US 2003/0079218 A (GOLDBERG et AL) See paragraphs 29 to 45 and figs 3a to 3e.
A	-	US 2013/0019205 A (GIL et AL) See whole document.

**Categories:**

X	Document indicating lack of novelty or inventive step	A	Document indicating technological background and/or state of the art.
Y	Document indicating lack of inventive step if combined with one or more other documents of same category.	P	Document published on or after the declared priority date but before the filing date of this invention.
&	Member of the same patent family	E	Patent document published on or after, but with priority date earlier than, the filing date of this application.

**Field of Search:**

Search of GB, EP, WO & US patent documents classified in the following areas of the UKC<sup>X</sup> :

Worldwide search of patent documents classified in the following areas of the IPC

The following online and other databases have been used in the preparation of this search report

**International Classification:**

Subclass	Subgroup	Valid From
None		