

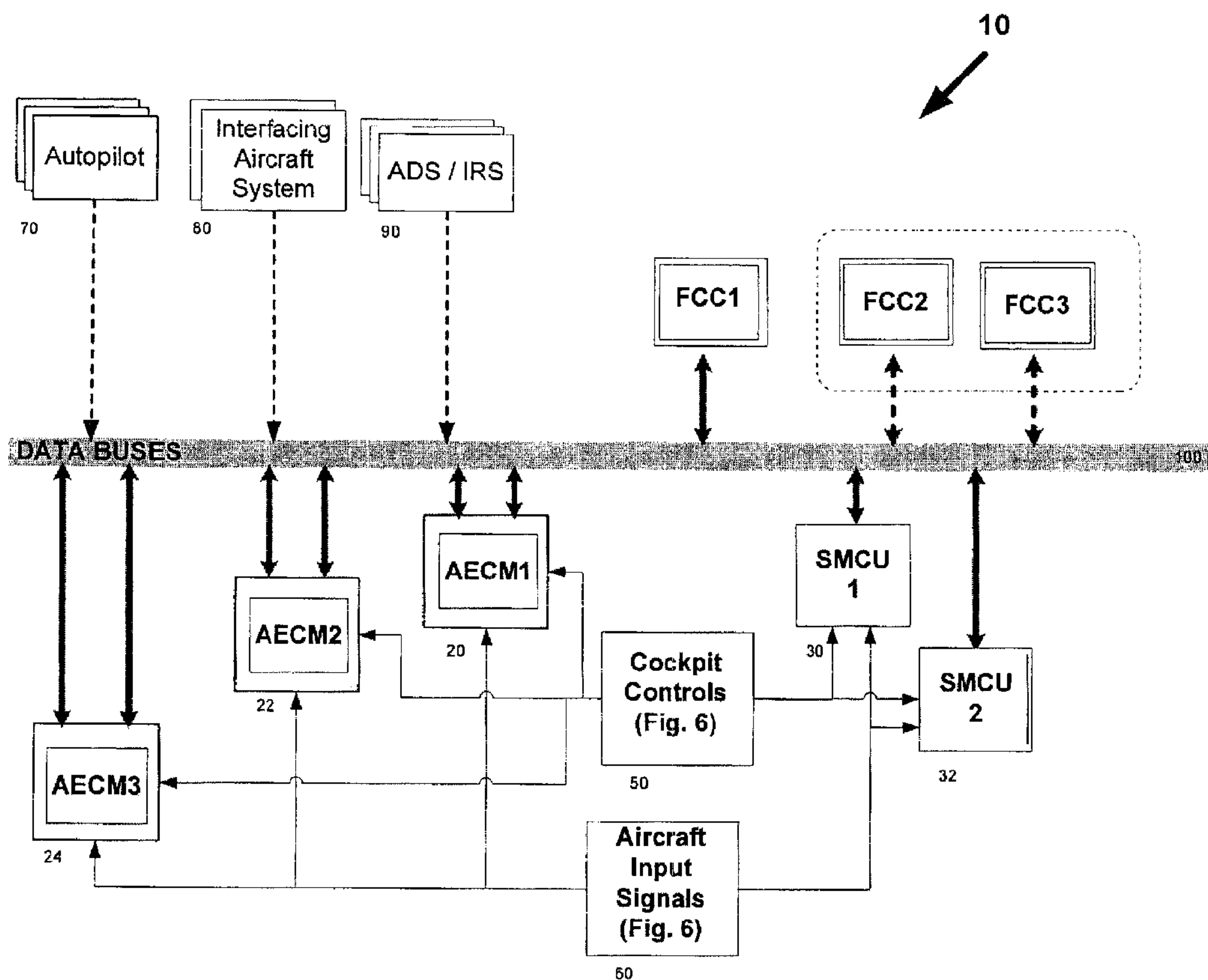

(86) Date de dépôt PCT/PCT Filing Date: 2008/03/26
 (87) Date publication PCT/PCT Publication Date: 2008/10/16
 (45) Date de délivrance/Issue Date: 2013/10/29
 (85) Entrée phase nationale/National Entry: 2009/10/05
 (86) N° demande PCT/PCT Application No.: GB 2008/050216
 (87) N° publication PCT/PCT Publication No.: 2008/122820
 (30) Priorité/Priority: 2007/04/05 (US60/921,955)

(51) Cl.Int./Int.Cl. *G05D 1/00* (2006.01),
B64C 13/50 (2006.01)
 (72) Inventeurs/Inventors:
LIN, SHU, CA;
SMITH, TIMOTHY, CA;
DE SERRES, PIERRE, CA
 (73) Propriétaire/Owner:
BOMBARDIER INC., CA
 (74) Agent: NORTON ROSE FULBRIGHT CANADA
LLP/S.E.N.C.R.L., S.R.L.

(54) Titre : SYSTEME DE COMMANDE DE VOL ELECTRIQUE MULTIVOIE. A CANAL UNIQUE ET REDONDANCE SERIE MULTIAXE
 (54) Title: MULTI-AXIS SERIALLY REDUNDANT, SINGLE CHANNEL, MULTI-PATH FLY-BY-WIRE FLIGHT CONTROL SYSTEM



(57) Abrégé/Abstract:

A multi-axis serially redundant, single channel, multi-path fly-by-wire control system (10) comprising: serially redundant flight control computers in a single channel where only one "primary" flight control computer is active and controlling at any given time; a matrix



(57) **Abrégé(suite)/Abstract(continued):**

of parallel flight control surface controllers including stabilizer motor control units (SMCU) and actuator electronics control modules (AECM) define multiple control paths within the single channel, each implemented with dissimilar hardware and which each control the movement of a distributed set of flight control surfaces on the aircraft in response to flight control surface commands of the primary flight control computer; and a set of (pilot and co-pilot) controls and aircraft surface/reference/navigation sensors and systems which provide input to a primary flight control computer and are used to generate the flight control surface commands to control the aircraft in flight in accordance with the control law algorithms implemented in the flight control computers.

(12) INTERNATIONAL APPLICATION PUBLISHED UNDER THE PATENT COOPERATION TREATY (PCT)

(19) World Intellectual Property Organization
International Bureau(43) International Publication Date
16 October 2008 (16.10.2008)(10) International Publication Number
WO 2008/122820 A3

(51) International Patent Classification:

G05D 1/00 (2006.01) B64C 13/50 (2006.01)

(21) International Application Number:

PCT/GB2008/050216

(22) International Filing Date:

26 March 2008 (26.03.2008)

(25) Filing Language:

English

(26) Publication Language:

English

(30) Priority Data:

60/921,955 5 April 2007 (05.04.2007) US

(71) Applicant (for all designated States except US): **BOMBARDIER INC.** [CA/CA]; Aerospace Headquarters, 400 Côte-Vertu Road West, Dorval, Québec H4S 1Y9 (CA).

(72) Inventors; and

(75) Inventors/Applicants (for US only): **LIN, Shu** [CA/CA]; 500 St Servan, Ste-dorothee, Québec H7X 3X8 (CA). **SMITH, Timothy** [GB/CA]; 34 Browning, Dollard Des Ormeaux, Québec H9G 2K4 (CA). **DE SERRES, Pierre** [CA/CA]; 1670 Rue Champigny, St-Laurent, Québec H4L 4P8 (CA).(74) Agent: **HARRISON GODDARD FOOTE**; Orlando House, 11c Compstall Road, Marple Bridge, Stockport Greater Manchester SK6 5HH (GB).

(81) Designated States (unless otherwise indicated, for every kind of national protection available): AE, AG, AL, AM, AO, AT, AU, AZ, BA, BB, BG, BH, BR, BW, BY, BZ, CA, CH, CN, CO, CR, CU, CZ, DE, DK, DM, DO, DZ, EC, EE, EG, ES, FI, GB, GD, GE, GH, GM, GT, HN, HR, HU, ID, IL, IN, IS, JP, KE, KG, KM, KN, KP, KR, KZ, LA, LC, LK, LR, LS, LT, LU, LY, MA, MD, ME, MG, MK, MN, MW, MX, MY, MZ, NA, NG, NI, NO, NZ, OM, PG, PH, PL, PT, RO, RS, RU, SC, SD, SE, SG, SK, SL, SM, SV, SY, TJ, TM, TN, TR, TT, TZ, UA, UG, US, UZ, VC, VN, ZA, ZM, ZW.

(84) Designated States (unless otherwise indicated, for every kind of regional protection available): ARIPO (BW, GH, GM, KE, LS, MW, MZ, NA, SD, SL, SZ, TZ, UG, ZM, ZW), Eurasian (AM, AZ, BY, KG, KZ, MD, RU, TJ, TM), European (AT, BE, BG, CH, CY, CZ, DE, DK, EE, ES, FI, FR, GB, GR, HR, HU, IE, IS, IT, LT, LU, LV, MC, MT, NL, NO, PL, PT, RO, SE, SI, SK, TR), OAPI (BF, BJ, CF, CG, CI, CM, GA, GN, GQ, GW, ML, MR, NE, SN, TD, TG).

Published:

- with international search report (Art. 21(3))
- before the expiration of the time limit for amending the claims and to be republished in the event of receipt of amendments (Rule 48.2(h))

(88) Date of publication of the international search report:

22 October 2009

(54) Title: MULTI-AXIS SERIALLY REDUNDANT, SINGLE CHANNEL, MULTI-PATH FLY-BY-WIRE FLIGHT CONTROL SYSTEM

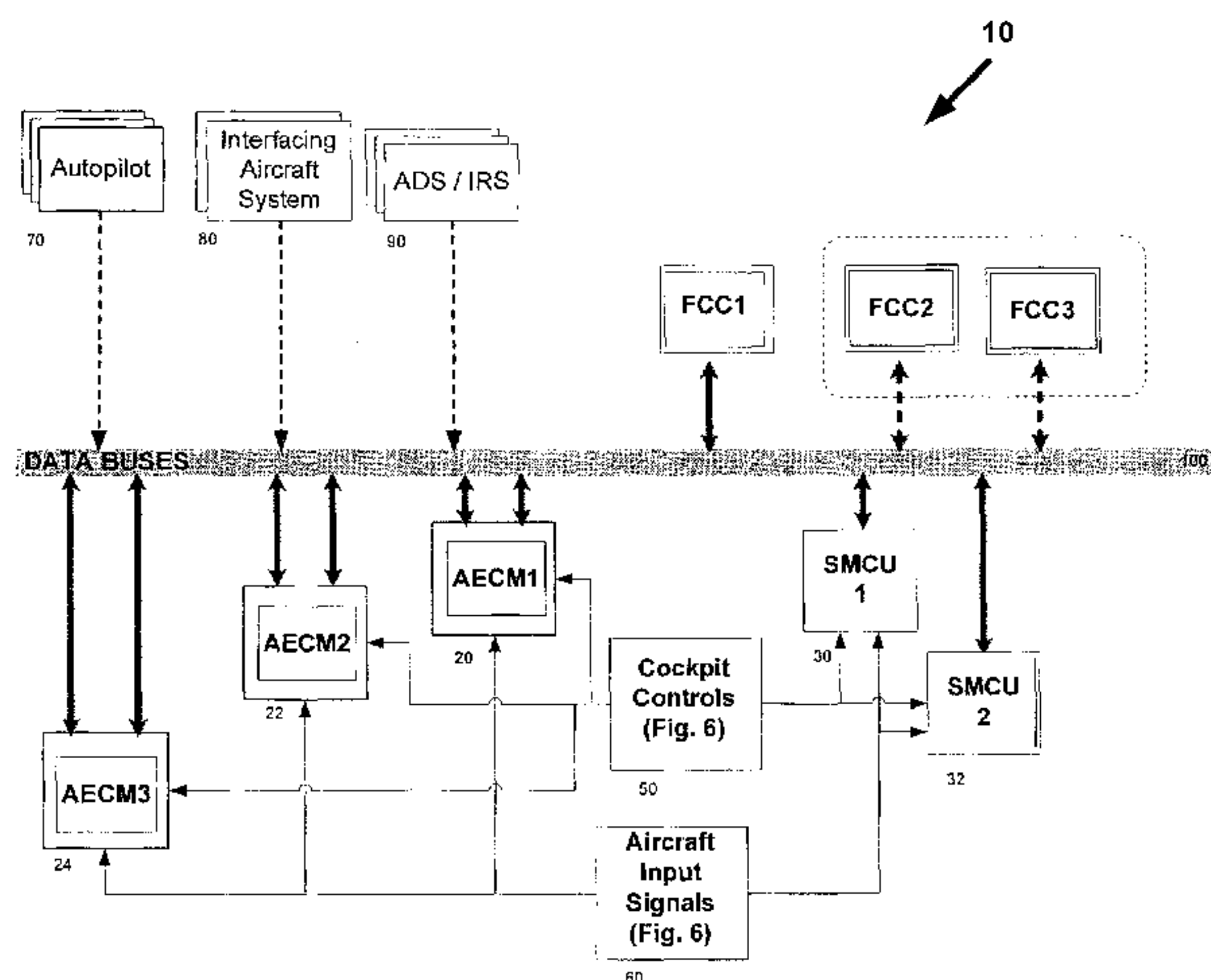

Fig. 5

(57) **Abstract:** A multi-axis serially redundant, single channel, multi-path fly-by-wire control system (10) comprising: serially redundant flight control computers in a single channel where only one "primary" flight control computer is active and controlling at any given time; a matrix of parallel flight control surface controllers including stabilizer motor control units (SMCU) and actuator electronics control modules (AECM) define multiple control paths within the single channel, each implemented with dissimilar hardware and which each control the movement of a distributed set of flight control surfaces on the aircraft in response to flight control surface commands of the primary flight control computer; and a set of (pilot and co-pilot) controls and aircraft surface/reference/navigation sensors and systems which provide input to a primary flight control computer and are used to generate the flight control surface commands to control the aircraft in flight in accordance with the control law algorithms implemented in the flight control computers.

WO 2008/122820 A3

TITLE

Multi-Axis Serially Redundant, Single Channel, Multi-Path Fly-By-Wire Flight Control System

FIELD OF THE INVENTION

5 The present invention generally relates to aircraft control systems and, in particular, to a multi-axis serially redundant, single channel, multi-path fly-by-wire flight control system.

BACKGROUND OF THE INVENTION

10 Fly-by-wire technology has provided a major advance in aircraft flight control systems.

 Mechanical flight control systems had been prevalent where the flight control surfaces on an aircraft were controlled using a system of cables, linkages and mechanical controls as the primary and usually only control paths. Only limited, basic mechanical failure mode contingency was possible in such systems.

15 With the advent of electronics and computer-aided flight controls, mechanical systems were given enhanced controllability through augmentation with, e.g., electrical drive assist and controls.

 Such improvements allowed for the development of advanced control laws that, among other things, improve and increase aircraft controllability and performance.
20 These control laws can be complex and their implementation in a mechanical control system, even those with electronic assistance, is difficult and often results in significant increase in aircraft weight.

 As the next step in relevant technological evolution, mechanical linkages (rods, cables, arms, etc) were replaced by motors, actuators and drives with associated
25 wiring as so-called "fly-by-wire" technologies were developed.

A simplified diagram of a known fly-by-wire (FBW) system is shown in FIG. 1. In such a fly-by-wire system, there is no direct mechanical coupling between the pilot controls 10 and a flight control surface 20. Known fly-by-wire systems include for example, a set of pilot controls 10 which provide electrical signals to aircraft electronics 5 24, where they are combined with other airplane data to produce flight control surface commands. Instead of mechanical linkages and their attendant displacement/translation, the commands are transmitted across wires 38 to electrically control the movement of actuator/motors 26 that move the flight control surfaces 20.

For purposes of safety, fly-by-wire systems typically include redundant 10 components so that if one component of the system fails, the aircraft can still be safely controlled. In such prior art systems, it is known to provide redundancy on an axis-by-axis basis. For example as shown in Fig. 2, some prior art fly-by-wire architectures have separate systems that control the movement of the aircraft in each of the roll, pitch and yaw axes.

15 In these prior art systems, each axis control system typically included a dedicated primary flight computer/processor and a back-up flight computer/processor that control movement of the aircraft in a particular axis. If the primary flight computer/processor that controls one axis were also to fail, the back-up computer/processor would engage to control that axis of the aircraft. Similarly, the other 20 axis systems would each include a primary and back-up flight computer/processor. However, if the back-up computer/processor in a particular axis channel were to fail, the computers/processors in the other axis channels could not function to fly the aircraft in the failed axis.

25 As an improvement to such systems, redundant multi-channel, multi-axes, fly-by-wire control systems such as shown in Fig. 3 were introduced, in which the fly-by-wire system is divided into a series of parallel independent control channels, each channel capable of flying the aircraft. Each control channel is substantially isolated from the other control channels such that the channels operate in parallel and provide redundancy

where in the event of a malfunction in or of one channel, the continued operation of the remaining channels is not affected and multi-axis controllability is maintained.

With reference to Figures 3 and 4, one such prior art fly-by-wire system includes three isolated identical control channels - a left flight control channel 60, a
5 center flight control channel 80 and a right flight control channel 90- each channel having its own dedicated primary flight computer 64, 84 or 94 and actuator control electronics unit (ACE) 62, 82 or 92, the ACE controlling a set of associated flight control surfaces 66. Each flight control channel is fully redundant and can control all axes of the aircraft.

As shown in Figure 4, pilot/co-pilot control inputs (via respective
10 transducer signals) are provided to each of ACEs 62, 82, and 92 which then make available the transducer signal over its designated one of three data buses 40, 42, and 44. The primary flight computers 64, 84, and 94 each receives transducer signals from each of the three data buses 40, 42, and 44. Each of the primary flight computers (left 64,
15 center 84 and right 94) selects one of the transducer signals received from one of the three ACEs to use in generating a set of flight surface commands, which particular transducer signal is selected by the flight computers is based on predetermined selection rules. After selecting a transducer signal from one of the three ACEs, left primary flight
20 computer 64 generates a set of proposed flight surface commands which are then transmitted over the data bus 40, while the center and right primary flight computers 84 and 94 transmit their sets of proposed flight surface commands on the center and right
25 data buses 42, and 44, respectively. The left primary flight computer 64 compares the set of proposed flight surface commands it has generated with the proposed flight surface commands generated by each of the other primary flight computers 84 and 94. In a mid-value select block 379a, the left primary flight computer 64 selects the middle value of
30 each of the flight surface commands. The left primary flight computer 64 then transmits the selected middle values of the flight surface commands over the left data bus 40, while the center and right primary flight computers transmit their selected middle value flight surface commands on the center and right data buses 42 and 44. The ACEs 62, 82 and 92 receive the respective sets of flight surface commands generated by each of the primary flight computers 64, 84, and 94. The left ACE 62 selects one of the sets of flight surface

commands generated by one of the three primary flight computers in accordance with the signal select function of an input signal management block where the ACE selects the commands from the flight control computer in its own channel. Once the ACE 62 has selected a set of flight surface commands, it applies the selected set of flight surface
5 commands to a servo loop, which controls an actuator 558a that moves the appropriate aircraft control surface. The operation of the center primary flight computer 84 and the right primary flight computer 94 are the same as that of the left primary flight computer 64 described.

In this fashion, this prior art fly-by-wire control system demonstrates a
10 plurality of independent and isolated flight control channels each channel including an actuator controller electronics unit (ACE) that receives transducer signals that are indicative of the position of the pilot controls and a primary flight computer that is coupled to that ACE and which generates flight surface commands based on the transducer signals received from the ACE. The ACE in each isolated flight control
15 channel receives the flight surface commands from the corresponding primary flight computer and sends the commands to a plurality of servo loops that control the movement of a set of flight control surfaces on the aircraft.

In this known system, each of the plurality of flight control channels is an independent, isolated, control channel, each of the plurality of flight control channels is
20 of identical configuration, and all of the plurality of channels operate in parallel, with redundancy incorporated through the parallel operation.

The set of flight control surfaces controlled by each isolated flight control channel is selected so that operation of a single isolated flight control channel is sufficient to fly the aircraft in the event that the remaining isolated flight control channels fail,
25 further characterizing the independent, isolated and redundant nature and aforementioned structure of this known flight control channel.

The foregoing is believed to describe the prior art systems as set forth, for example, in USP 5,493,497.

Such parallel structure requires that all independent channels are active in normal mode function and operate in a synchronized (e.g., real-time) fashion. Failure mode monitoring requires flight control commands to be constantly compared between the simultaneously operating redundant control channels. In the failure operation of these
5 types of systems, if one primary flight computer fails, the remaining ones continue to operate all channels under a failure management scheme and control the aircraft.

While the above prior art fly-by-wire system provides redundant control channels such that the aircraft can be controlled safely by one channel in case of failures of other channels, one drawback of the prior art is that a generic fault at the ACE level
10 (e.g., batch failure - manufacturing defects) could affect all ACEs, which could degrade the controllability of all surfaces. Another drawback is the need for duplicative components to achieve functional operation of such prior art redundant system.

SUMMARY OF THE INVENTION

The present invention provides advancements in the state of the relevant
15 art by, *inter alia*, providing a multi-axis serially redundant, single channel, multi-path, generic fault tolerant fly-by-wire aircraft control system in which internal architectural dissimilarities are provided for all critical flight control electronics such that the aircraft can be controlled safely in case of multiple control electronics failures and the system is also fault tolerant to a generic fault of computer/processor, or a generic fault of other
20 complex hardware.

In accordance with one aspect of the present invention, the multi-axis serially redundant, single channel, multi-path, generic fault tolerant fly-by-wire control system comprises: serially redundant flight control computers (FCC) where only one of the computers, the "primary" flight control computer, is active and controlling at any
25 given time; a matrix of parallel redundant flight control surface controllers including Stabilizer Motor control units (SMCU) and actuator electronics control modules (AECM) which each control the movement of a distributed set of flight control surfaces on the aircraft in response to flight control surface commands of the primary flight control

computer; and cockpit controls and aircraft surface/reference/navigation sensors and systems which provide inputs to the flight control computers and are used to generate the flight control surface commands to control the aircraft in flight in accordance with the control law algorithms implemented in the flight control computers. Each AECM/SMCU
5 constitutes a control path in the single flight control channel of the present invention.

In the described embodiment, the individual AECMs each comprise 2 types of hardware dissimilar submodules and the SMCUs are dissimilar from the AECMs. The flight control surfaces are distributed among AECMs and SMCUs such that the aircraft can be controlled safely in the event of any “three combination” failures of
10 the AECM submodules and SMCUs. The aircraft can also be controlled safely in case of generic fault of any one type of AECM modules.

During normal operation, the active primary FCC provides commands to all AECMs and SMCUs, while the other two FCCs operate in a standby (i.e., non-controlling) mode. If the primary FCC determines under a self-monitoring regime that it
15 has failed, it will be taken off-line and a second FCC will come on-line as the active primary FCC and provide commands to all AECMs and SMCUs. Similarly, if the second, now designated primary, FCC fails, it will be taken off-line and a third FCC will come on-line as the active primary FCC and provide commands to all AECMs and SMCUs. In the event of a failure of the last available FCC, the system of the present
20 invention will revert to AECM/SMCU direct mode operation where the flight control surfaces can be directly commanded through direct mode control laws.

Each FCC is constituted from a command lane and a monitor lane with dissimilar processors (command lane – A type and monitor lane – B type). In case of a generic fault of FCC command lane processor or monitor lane processor, all FCCs will be
25 taken off-line and the system will revert to the AECM/SMCU direct mode operation.

It will be appreciated by those skilled in the art that the foregoing brief description and the following detailed description are exemplary and explanatory of this invention, and are not intended to be restrictive thereof or limiting of the advantages

which can be achieved by this invention. Thus, the accompanying drawings, referred to herein and constituting a part hereof, illustrate preferred embodiments of this invention, and, together with the detailed description, serve to explain the principles of this invention.

5

BRIEF DESCRIPTION OF THE DRAWINGS

Additional aspects, features, and advantages of the invention, both as to its structure and operation, will be understood and will become more readily apparent when the invention is considered in the light of the following description of illustrative embodiments made in conjunction with the accompanying drawings, wherein:

10

FIG. 1 is a general representation of a prior art fly-by-wire aircraft flight control system;

FIG. 2 is a simplified schematic diagram of a prior art fly-by-wire control system capable of controlling only one aircraft axis;

15

FIG. 3 is a block diagram of a known multi-channel, parallel redundant fly-by-wire control system;

FIG. 4 is an operational diagram illustrating the multi-channel, cross-channel interactive, parallel operation of the fly-by-wire control system of Fig. 3;

FIG. 5 is a block diagram of a serially redundant multi-axis fly-by-wire control system according to an illustrative embodiment of the present invention;

20

FIG. 6 is a detailed diagram of a portion of the FBW system of Fig. 5;

FIG. 7 is an illustrative block diagram showing an AECM of Fig 6;

FIG. 8 is a detailed illustrative diagram of the AECM3D of Figure 7; and

FIG. 9(A-E) is a diagram showing the distributed control surfaces of the AECMs and SMCUs illustrated in Fig 6.

DETAILED DESCRIPTION OF THE PREFERRED EMBODIMENT

The flight control system of the present invention is a fly-by-wire multi-axis flight control system that is fault-isolated, fault tolerant, fail-safe and fail-operational. Its architecture and operational details will be discussed in detail below in the context of an illustrative embodiment and with reference to the figures provided.

GENERAL OVERVIEW

The illustrative embodiment of the multi-axis serially redundant, single channel, multi-path fly-by-wire flight control system (FCS) of the present invention includes a single control channel architecture based on serially redundant flight computers and comprising within the channel a plurality of control paths each with its own dissimilar hardware flight control surface controllers, which paths together, in the single channel, provide manual and automatic control of the aircraft in each of the pitch, roll and yaw axes through a matrix of complementary distributed control surfaces responsive to commands generated by the flight computers in accordance with predetermined control law algorithms.

The fly-by-wire FCS of the present invention in the illustrative embodiment has two operation modes: Normal mode and Direct mode. The Normal mode is the system default operation mode and provides fully augmented flight control capability with flight envelope and structural protections. The Direct mode is command by wire, i.e. the pilot directly commands flight control surface position with stability augmentation and command limiting in pitch and yaw axes. A block diagram of the architecture of the illustrative fly-by-wire FCS according to the present invention is shown in FIG. 5.

With reference to Figure 5, the illustrative fly-by-wire FCS control system comprises multiple flight control computers FCC1, FCC2 and FCC3, flight control surface controllers including actuator electronics control modules (AECM) 20, 22, 24 and stabilizer motor control units (SMCU) 30 and 32, cockpit controls 50, and aircraft subsystems which provide aircraft input signals 60 and additional data from avionics (e.g.

autopilot or navigation systems) 70, aircraft systems 80 and Air Data System (ADS)/Inertial Reference System (IRS) 90.

The signals from the various cockpit controls 50 and aircraft inputs 60 are received and processed by the AECMs and transmitted to the FCCs via data bus 100. The signals from the various cockpit controls 50 and selected aircraft inputs 60, in the current embodiment Flap/slat discrete data, are received and processed by the SMCUs and transmitted to the FCCs via data bus 100. Other systems e.g., avionics 70, aircraft systems 80 and ADS/IRS 90, also interface to data bus 100. In the present embodiment, the data bus architecture will include an ARINC 429 digital communication link, which is standard in the aircraft industry, and each FCC communicates with each AECM and SMCU through a dedicated ARINC 429 data bus; however, other types of data communication links could be used. For purposes of illustrative simplicity, a single data bus 100 is shown. Other bus configurations can be implemented, such as for example, using different bus protocols or multiple data buses, as will be understood by one skilled in the art.

In the illustrative embodiment, triple serial redundant Flight Control Computers FCC1, FCC2 and FCC3 perform Normal mode control/monitoring functions. As will be explained in detail infra, the FCCs each receive input from the AECMs and other above mentioned sources, via data bus 100, and calculate command signals based on control law algorithms implemented in the FCCs. Autopilot system 70 (Fig. 6) can provide computer control of the aircraft without the need for direct pilot or copilot input. Upon engagement of the autopilot system 70, the FCCs generate the flight surface commands based on signals received from the autopilot system 70 instead of the pilot control signals received from the AECMs.

While any single FCC (FCC1, FCC2 or FCC3) is capable of providing full control functionality in all aircraft axes, the three FCCs operate independently in an active/standby configuration, with no output command voting/comparison between the computers. In this active/standby scheme, while the three FCCs operate in synchronous fashion for failure mode operation as will be discussed in detail below, only one FCC is

active at any given time: in this embodiment for example, one FCC (FCC1) is designated the default active “primary” FCC, and the other 2 FCCs (FCC2 and FCC3) each operate independently in a passive “standby” mode to serially come on-line as the “new” primary FCC in the event of failure of the prior active primary FCC (FCC1).

5 With reference to Fig.6, the cockpit controls 50 and flight control surface controllers AECM and SMCU of Fig. 5 are described in further detail.

Cockpit controls 50 include a pilot and co-pilot sidestick controller 51P, 51C, each in a typical implementation of a pistol grip for inputting pitch and roll commands. The sidestick controllers 51P and 51C (through transducers which translate
10 mechanical displacement to an electrical signal) each generate and provide signals (position or rate) which are coupled to each of the AECMs and SMCUs as shown. Each sidestick controller has a pitch trim switch 52P and 52C, which are coupled to each SMCU as shown.

Also included among the cockpit controls 50 are a set of pedals 53P and
15 53C for directional (rudder) control with rudder feel and centering, and rudder trim switch 55 for controlling the rudder trim actuator. Pedals 53P and 53C (through transducers which translate mechanical displacement to an electrical signal), and rudder trim switch 55, each generate and provide signals (position or rate) which are coupled to each of the AECMs as shown.

20 Cockpit controls 50 include stabilizer cutout switches 57 which provide input to each of the SMCUs, lateral trim switch 56 for controlling roll trim. Flight Spoiler Control Lever (FSCL) 54 which provides input to each of the AECMs and Sidestick Priority Inputs (such as Pilot, Co-Pilot Stick Priority and glareshield priority switches). The set of pitch trim switches (52P and 52C) generate appropriate pitch
25 stabilizer trim command signal(s) which is/are transmitted to the FCC, via the SMCUs, over data bus 100, while the rudder trim (55) and lateral trim (56) switches generate appropriate rudder and roll stabilizer trim command signal(s) which is/are transmitted to the FCC, via the AECMs, over data bus 100. Other inputs 60 (as will be detailed in the

discussion of Fig. 7) are also provided to the AECMs, which include Analog, Discrete and Sidestick Priority inputs.

In the discussed embodiment, multiple Actuator Electronic Control Modules (AECM), 20, 22 and 24, perform actuator servo loop closure and thereby
5 control the associated distributed control surfaces (See Fig. 9) in Normal mode, based upon commands from the FCCs as will be discussed in detail. The AECMs also perform Direct mode control and monitoring functions as will be described.

In the exemplary embodiment, AECMs 20, 22, 24 are field programmable gate array (FPGA) based and each AECM comprises two hardware dissimilar
10 submodules: AECM1 comprises submodules AECM1C and AECM1D; AECM2 comprises submodules AECM2C and AECM2D; and AECM3 comprises submodules AECM3C and AECM3D. By “dissimilar” in this context, is meant that type “C” AECM submodules are built with dissimilar, in this embodiment FPGA, hardware than type “D” AECM submodules. This has the benefit of increasing tolerance to generic failures.

15 Although the type C and D AECM submodules are FPGA based in the present embodiment, the AECM submodules could be microprocessor based, or any other type of complex hardware devices, or constructed using only analog devices. In addition, the AECMs can be designed to include other than 2 submodules: 1 or more than 2, both within the teachings of the invention described herein. Also, the dissimilar hardware in
20 each AECM submodule does not need to be of the same hardware type- in other words submodule C can be FPGA while submodule D can be microprocessor based. Such is within the scope of the present invention with required changes necessitated by hardware design choice being understood by those of ordinary skill.

Each submodule AECM1C, AECM1D, AECM2C, AECM2D, AECM3C
25 and AECM3D constitutes a control path within the single flight control channel. Flight control surfaces are distributed such that each AECM submodule and consequently each AECM, operates independently and controls a different set of actuators related to each of the three flight control axes (pitch, roll and yaw) (see e.g., 21, 23 and 25 in Fig. 9). The two dissimilar submodules per AECM scheme constrains the failure effect of a complex

hardware generic fault and allows for sufficient control for continued safe flight and landing in case of generic fault of AECM submodule type C or D.

Two Stabilizer Motor Control Units (SMCUs) 30 and 32 are used in the illustrative embodiment to control the horizontal stabilizer trim actuator (HSTA) (see Fig 9). As they control the HSTA for Normal and Direct mode horizontal stabilizer trim, the SMCUs are of a different design from (and therefore hardware dissimilar to) the AECMs. Similarly as for the AECMs, whereas each SMCU in the present embodiment is implemented as a single unit, the SMCUs could be designed to include 2 or more internal subunits.

In the illustrative embodiment, the SMCUs also include an analog-direct-link “ultimate” backup function which provides controllability of pitch trim, one elevator and one aileron actuators per SMCU. The ultimate backup function is not active during Normal or Direct mode operation but is only activated as a contingent last resort redundancy in the event of failure of both Normal and Direct modes, and will provide short term safe flight capability, e.g., while attempting to restore the primary flight control system to the Normal/Direct mode after a temporary drop off of all AECMs.

As used in the foregoing discussion and throughout the description of this exemplary embodiment of the present invention, and as will be understood from the preceding discussion, the term “flight control surface controller” is an abstracted term to convey a mechanism to control the various flight control surfaces of an aircraft. Many types of flight control surface controllers are known. The flight control surface controllers used in the illustrative embodiment of the present invention include the AECM and SMCU. In the description herein, the AECM is referred to at a system level as a module and the hardware design of each module is such that each module includes submodules. The SMCUs of the illustrative embodiment, on the other hand, are implemented as single units; that is, they are not internally implemented as multiple subunits in the way the AECMs are internally structured. Such naming convention has been used for purposes of illustrating functionality and operability and is not meant in and of itself to limit the architecture of the flight control surface controllers of the present

invention. The redundant parallel functionality of the submodule implementation of the AECMs is one aspect of the invention. For purposes of illustration, in the example embodiment, the SMCUs are not designed with such internal parallel subunit redundancy, but may be if so desired.

5 With reference to Figs.7 and 8 and the detailed discussion of each figure which follows, AECM3 (24) is highlighted for illustration. In the exemplary embodiment described herein, AECM1 and AECM2 are similarly implemented.

 As can be seen in the illustrative functional block diagram of Fig 7, AECM3 (24) contains submodules AECM3C (24C) and AECM3D (24D). Each FCC (FCC1, FCC2 and FCC3) comprises command/monitor lanes with dual dissimilar processors (command lane – “A” type and monitor lane – “B” type) as explained in more detail below.

 Inputs 700 to AECM3 include: Cockpit Control Inputs 50 (such as FSCL, rudder pedal, sidestick controllers for pilot and co-pilot pitch and roll control inputs);
15 Analog & Discrete Inputs 60 (such as Signal for stickshaker pilot cues, OEI (One Engine Inoperative) discrete, Flap/slat discrete, Stabilizer position, Rudder trim position, Aileron trim switch, Yaw rate and Pitch rate sensors (for direct mode operation)); and Sidestick Priority Inputs 50 (as outlined above). All these inputs (700) are received through a common backplane 24B and the same inputs are shared between submodules AECM3C
20 and AECM3D.

 Since inputs 700 are analog or discrete signals, possible failures of these signals and their failure impacts to the system can be easily analyzed and verified during the fly-by-wire system design. Dissimilarity is thus not necessary and therefore is not included in the illustrative embodiment. In this way, the two types of AECM submodules
25 share the same backplane (24B) and inputs (700) and therefore reduce the complexity of the AECM and the fly-by-wire system. However should dissimilarity or further isolation be desired, such is nonetheless within the scope of the present invention and may be included in system design, for example, through the implementation of two separate

backplanes (one for each AECM submodule) as will be understood by those skilled in the art.

Actuation control input electronics block 810C, 810D receive and process inputs 700 and provide sensor excitation. Data concentrator 850C, 850D collects input
5 signals from input electronics 810C, 810D and provides these signals to the FCCs via data bus 100. FCC command block 860C, 860D receives command signals generated by the individual FCCs.

In the (although highly improbable) event of a failure of all FCCs, all FCCs are taken off line and the system will revert to operate in AECM/SMCU Direct
10 mode where the pilot will directly control the various aircraft surfaces. AECM/SMCU Direct mode operation is completely independent from FCC software/hardware and is responsive to cockpit controller inputs. Similarly, should loss of or insufficient aircraft sensor/system data occur, Normal Mode operation will be lost and the system will revert to Direct mode. The illustrative embodiment design is such as to minimize the possibility
15 of common cause failure that would result in loss of both Normal and Direct modes.

Direct mode control law algorithms are implemented via Direct Mode Control Block 820C, 820D, which receives the input signals from block 810C, 810D.

Normal or Direct mode switching is controlled by switching block 830C, 830D that, in Normal mode, allows control of the control surfaces to be commanded by
20 the primary FCC. When switched to Direct mode operation, the FCC command path is disengaged such that the pilot can control the aircraft via Direct mode control law paths in the Direct Mode Control Block 820C, 820D, as further outlined below.

Servo control electronics 840C, 840D responsive to either primary FCC commands in Normal mode or direct commands in Direct mode, are used to drive the
25 respective control surfaces in response to calculated commands. Power supply 870C, 870D provides, in this case DC, power to the AECM.

As discussed above, the AECMs receive the cockpit control signals and execute the flight surface commands generated by the primary FCC in order to control the movement of the set of flight control surfaces associated with that AECM. In the illustrative embodiment, as previously discussed, each of the AECMs in the fly-by-wire system are interchangeable and are each designed to include 2 hardware dissimilar submodules so as to effectively constitute 6 AECMs governing 6 independent control paths.

With reference to Fig. 8, AECM functionality is discussed in detail, using submodule AECM3D (24D) for illustration. Implementation and operation of other AECM modules and submodules will be understood to be similar.

AECM3D has an internal DC power supply 870D that is connected to an independent power bus - in this case 28v DC bus 3. AECM3D (24D) includes a data bus interface (850D and 860D) that connects AECM3D to each FCC through data bus 100. In the present embodiment, AECM3D communicates with each FCC through an individual data bus, however, multiple common data buses could be used. AECM3 further includes an internal data bus on backplane 24B over which data within AECM3 is routed.

The cockpit control signals are applied via backplane 24B to actuation control input electronics block 810D. Input block 810D also receives analog and discrete signals as well as sidestick priority inputs (inputs 700 discussed above with respect to Fig 7). Included within actuation control input electronics block 810D is cockpit (pilot/co-pilot) sensor excitation and demodulation circuitry.

After receiving the cockpit control signals in actuation control input electronics block 810D, an analog-to-digital (A/D) converter converts the control signals from an analog format to a digital format and transfers the converted cockpit control signals to the internal data bus for transmission as digital data to the FCCs over data bus 100. The digital data is also transmitted to block 820D, which will be used by the AECM Direct mode control law.

Data concentrator 850D collects all cockpit controller, switch and discrete data to supply to all FCCs (FCC1, FCC2 and FCC3).

In the FCCs, the cockpit control signals are combined with data obtained from the various sources discussed with respect to Figs. 5-7, using control laws to
5 calculate a set of flight surface commands that will be used by AECM3D to control its assigned set of flight control surfaces.

The calculated flight surface commands are transmitted from the FCCs (FCC1, FCC2 and FCC3) to AECM3D (24D) via data bus 100 where they are received by AECM3D through FCC Command Decode Logic block 860D. Block 860D also
10 includes a sub block (FCC validity block), which checks for the FCC validity status and identifies the primary FCC.

Each FCC is comprised of a command lane and a monitor lane with dissimilar processors (type A processor for command lane and type B processor for monitor lane), which compare against one another. In a self-testing regime, a
15 discrepancy outside a predetermined tolerance between the command and monitor lanes will result in the affected FCC taking itself offline and its status being set as invalid, that status indicated to the AECMs ("FCC invalid").

The primary FCC will be determined at the FCC level among three FCCs and indicated to the AECMs. Various alternatives of determining a primary FCC may be
20 implemented, for example, a basic scheme could use priority logic such that FCC1 is the designated default primary FCC as long as FCC1 is valid and where FCC 1 is invalid, FCC2 would become primary as long as FCC2 is valid and so on. Other discrimination schemes may also be devised and implemented as will be understood.

Block 860D will receive and check for the FCC validity status (valid or
25 invalid) and identify the functional primary FCC. Only the functional primary FCC commands will be used by AECM3D, however the primary FCC commands will not be sent through to the actuator servo control block 840D unless the primary FCC has been confirmed as valid.

With reference to Fig. 8, actuation control input electronics block 810D and input actuator servo control block 840D also implement a command and monitor lane architecture using parallel lanes for fault monitoring. Other fault monitoring schemes may also be devised and implemented as will be understood by those skilled in the art.

5 Although not illustrated above, the FCC validity sub block may also include other means for input signal checks, such as, Cyclic Redundancy Check (CRC), watchdog timer, etc. Also, the decoded FCC commands by block 860D could be wrapped back to the FCC for comparison with the FCC original commands to ensure that the correct FCC commands have been used by the AECM3D.

10 Normal/Direct Mode Switching Block 830D selectively connects servo loops that control the flight control surfaces to receive either the flight surface commands output from the primary FCC via FCC Command Decode Logic block 860D, or to receive signals generated from Direct mode control law block 820D (which direct mode control laws are illustrated to include Pitch, Lateral and Directional paths).

15 If the FCC validity block (sub block of 860D) detects that there is no valid FCC available, or no primary FCC available, it will instruct the switching block 830D to disconnect the FCC commands (block 860D) and to connect Direct mode control block 820D with the PCU servo controls (block 840D).

20 Thus, in Normal mode operation, FCC Command Decode Logic block 860D allows only the commands from the primary FCC, in this case FCC1, to pass through to Normal/Direct Mode Switching Block 830D to control the assigned flight control surfaces.

25 In Direct mode, the associated flight control surfaces are controlled directly in response to the cockpit control signals via direct mode control law block 820D.

In the illustrative embodiment discussed, in Normal mode, the flight control surface controllers, for example as discussed for AECM3 above, will each receive

flight control commands from each of the FCCs (primary and standby) and FCC Command Decode Logic block 860D will forward only commands from the primary FCC to Normal /Direct Mode Switching block 830D, and consequently, the flight control surface servo loops are driven by the commands from the primary FCC. It will be understood by those skilled in the art that such command/control functionality can be, in alternative embodiments, integrated at other points in the control path of the single channel such that, for example, only the designated primary FCC transmits its flight commands onto the databus and/or that each flight control surface controller will only receive one set of flight control commands- i.e., those from the primary FCC. Such different scheme(s) would impose attendant changes in the illustrative embodiment as will be understood, such as in regards to placement of the FCC Command Decode Logic block 860D equivalent function where such function would be removed from the flight control surface controller and disposed at an appropriate place upstream in the control path. Nonetheless, moving such functionality to other segments of the control path in the single channel are considered to be within the scope of the present invention and to come under the teachings hereof, as the location of such functionality is not critical to such functionality in the context of the present invention. Other differences in implementation can also be devised where implementation will be accordingly effected.

As outlined above, the AECM submodules in the present embodiment are FPGA based, with the result that the majority of the functions in input block 810, control block 820, switching block 830 and control block 840 are performed by digital devices. As a result, in the present embodiment, A/D conversion occurs in input block 810 and D/A conversion occurs in control block 840. Alternatively, the AECMs could be analog based devices, in which case the A/D and D/A conversions would occur in data bus interfaces 850 and 860 respectively. Having analog based AECMs allows the design of FBW systems with direct mode operation occurring entirely analogically. The resulting advantage in simplicity and robustness may however be tempered by issues such as reduced flexibility during the development phase (in terms of scalability), reduced fault detection and maintenance capabilities, increased weight and higher life cycle costs.

However, either embodiment is possible pursuant to the invention, as are others, and all will be deemed to be within the scope of the invention as described herein.

In either Normal or Direct mode operation, AECM3D controls the movement of a set of distributed flight control surfaces (See Fig. 9) by applying the flight control surface commands to the plurality of PCU servo control loops, each of which controls a hydraulic actuator connected to one of the flight control surfaces.

Also included among the AECM inputs 700 are pitch and yaw rate sensor (see analog inputs 60, Fig. 7) that provide rate damping input to the elevator or rudder servo loop when the fly-by-wire system is operated in the Direct mode.

With reference to Fig. 9, the single control channel architecture of the present invention controls the pitch, roll and yaw axes through a matrix of distributed control surfaces via multiple control paths.

Although not illustrated, deployment of flight control surfaces are generally understood and incorporated on the aircraft main wing and on the aircraft tail. The control surfaces included on the wings are ailerons and multifunction spoilers. The control surfaces included on the tail section include a rudder, elevators and stabilizer. In the illustrative embodiment of the fly-by-wire flight control system of the present invention, the control surfaces are split and/or controlled as follows. The aileron and elevators are divided into left and right side surfaces, each surface powered by two hydraulic actuators: left inboard (LIB) and left outboard (LOB), right inboard (RIB) and right outboard (ROB). The multifunction spoilers (MFS) are divided into left and right side 1st, 2nd, 3rd and 4th portions, each with a hydraulic actuator drive. The rudder is a single surface but driven by three hydraulic actuators: upper, middle and lower. The stabilizer is a single wing surface controlled by two drives (which in the illustrative embodiment are electric motors). The ground spoilers are divided into left and right surfaces, each powered by a single hydraulic actuator. The flight control surfaces (with the exception of the spoilers and rudder) are generally positioned by two actuators, each of which is controlled by a separate path distributed among the AECMs and SMCUs.

In the present embodiment, each AECM submodule in an AECM module is powered by a separate DC bus (for example, AECM 3D is powered by DC bus 3 and AECM 3C is powered by DC bus 2). However, redundant power supplies could also be used for each AECM submodule such that, for example, both DC bus 2 and DC bus 3 could supply power to each of AECM 3C and AECM 3D. Because of the higher DC Voltage requirement of the horizontal stabilizer trim actuator (when compared to the other actuators), the SMCUs are each provided AC power by different busses, which is then converted to the required DC Voltage by the SMCUs. Furthermore, in an alternative embodiment of the present invention, the AC power provided to the SMCUs can also be supplied from air driven generators thereby providing an extra level of redundancy.

Pitch axis control is effected under the illustrative embodiment of the present invention through the use of two elevators and one moveable Horizontal Stabilizer; minimum pitch control (needed for the aircraft continued safe flight and landing) can be maintained as long as both elevators are available, or any one elevator is available combined with the horizontal stabilizer trim. Roll axis control is effected under the illustrative embodiment of the present invention through two ailerons and four pairs of multifunction spoilers; minimum roll control (needed for the aircraft continued safe flight and landing) can be maintained by both ailerons, or by two pairs of MFS, or one aileron plus one pair of MFS, or any combinations of ailerons and MFS that can provide 1/3 of roll control power. Yaw axis control is effected the illustrative embodiment through a single rudder; while the rudder is used as the primary means for the aircraft yaw control, yaw axis control can also be achieved through the use of differential engine thrust, so that rudder control loss is not critical to aircraft safety. Such total rudder control loss however is not likely as any single rudder actuator (of the 3 rudder actuators) can operate the rudder so for there to be total rudder control loss, all three rudder actuators would need to fail at the same time, which is highly improbable. In addition to their role in controlling the lateral axis in flight, the multifunction spoilers also provide a speed brake function through the inputs from FSCL and, together with one pair of ground spoilers, provide the ground lift dump function.

In the present invention, the flight control surface actuators are distributed among the three AECMs/6 AECM submodules and two SMCUs so as to address and accommodate multiple AECM/SMCU failures. More specifically, the flight control surface actuators are distributed such that one of the AECMs – a “Critical” or “Super” AECM- can safely control the aircraft in the event that all remaining AECMs and all SMCUs would fail, with the other AECMs - the “Non-Critical AECMs”- being able to control the aircraft in the event that all remaining AECMs and all SMCUs but one would fail. In the illustrative embodiment, as can be understood through the selection of distributed control surfaces under its control, the Critical AECM is AECM3 and the Non-Critical AECMs are AECM1 and AECM2. As discussed, each AECM consist of two hardware dissimilar submodules (C and D), the flight control surface actuators are further distributed such that one set of AECM submodules can safely control the aircraft in the event that the other sets of AECM submodules and all SMCUs would fail. For example, in the illustrative embodiment, should all type “C” submodules suffer a generic fault (i.e. AECM1C, AECM2C and AECM3C), the remaining type “D” submodules (i.e. AECM1D, AECM2D and AECM3D) can safely control the aircraft even in the event that all SMCUs would fail.

In the illustrative embodiment of the invention, pitch axis control is achieved through the following flight control surface actuator distribution. As outlined above, minimum pitch axis control is achieved through control of both elevators or through control of one elevator and one horizontal stabilizer trim. With each elevator being controlled by 2 elevator actuators (for a total of four), one elevator actuator for each elevator is allocated to the Critical AECM, with each Non-Critical AECM receiving one of the remaining two elevator actuators. With respect to the allocation, within each AECM, the allocation of the elevator actuators is such that each set of controllers controls one elevator actuator for each elevator, i.e., each submodule (C and D) controls a left side and a right side elevator actuator. With the horizontal stabilizer trim being controlled by a single actuator, such actuator is redundantly allocated to each SMCU i.e. each of the motors that power the actuator is allocated to an SMCU. Finally, the elevator actuators allocated to the Critical AECM have redundant backup allocated to each SMCU.

In the illustrative embodiment of the present invention, roll axis control is achieved through the following flight control surface actuator distribution. As outlined above, minimum roll control is achieved through control of both ailerons, through control of two pairs of MFS or through control of one aileron and one pair of MFS (or through
5 control of any combinations of ailerons and MFS that can provide 1/3 of roll control power). With each aileron being controlled by 2 aileron actuators (for a total of four), one aileron actuator for each aileron is allocated to the Critical AECM, with one Non-Critical AECM receiving the remaining two aileron actuators. With each pair of MFS being controlled by a pair of MFS actuators (for a total of 4 pairs of actuators), two pairs of
10 MFS actuators are allocated to the Non-Critical AECM which is not allocated an aileron actuator, with the other Non-Critical AECM and the Critical AECM each receiving a pair of MFS actuators. Finally, the ailerons actuators allocated to the Critical AECM have redundant backup allocated to each SMCU.

Finally, in the illustrative embodiment, yaw axis control is achieved
15 through the following flight control surface actuator distribution. As outlined above, minimum yaw control is achieved through control of the single rudder. With the rudder being capable of being operated by any single rudder actuator (out of the 3), each such actuator is allocated to each AECM.

The above flight control surface actuator distribution is complemented
20 with the hydraulic power and electrical power allocations to ensure that the aircraft can be controlled safely in the event of loss of any two hydraulic systems, or loss of any two electrical buses, or loss of any one hydraulic system combined with any one electrical bus. In the illustrative embodiment, each DC Power source is allocated to 2 of the 6 AECM controllers, so that each AECM is powered by a different power source
25 combination. Each SMCU is powered by a dedicated AC Power source. With respect to hydraulic power systems, each of the three AECM modules is allocated a different hydraulic power source, with the Critical AECM being allocated the hydraulic power source that is the more failure tolerant (in the exemplary embodiment, such hydraulic power source is tolerant of double engine failure). Such more failure tolerant hydraulic
30 power source also is allocated to the SMCUs. For further failure tolerance, the horizontal

stabilizer trim actuator is powered not by hydraulic power sources but by electrical motors.

Shown in Fig. 9 are the distributed flight surfaces/actuators of the fly-by-wire FCS of the illustrative embodiment of the present invention, which satisfy all above
5 criteria for actuator distribution.

Shown in the following tables are the flight control surfaces/actuators controlled by a particular AECM controller and SMCU, and the power (hydraulic and electrical) supplied in the illustrative embodiment.

Fig. 9A SMCU1 (30)

Actuator Power	Control Unit Power	Allocated Surface
E-Motor 1	3B (AC)	Horizontal Stabilizer
Hydraulic System 3	3B (AC)	LIB aileron ultimate backup
Hydraulic System 3	3B (AC)	LIB Elevator ultimate backup

10 The LIB aileron ultimate backup and LIB elevator ultimate backup are hydraulic actuated in this embodiment; however, they may also be electrically actuated.

Fig. 9B SMCU2 (32)

Actuator Power	Control Unit Power	Allocated Surface
E-Motor 2	2B (AC)	Horizontal Stabilizer
Hydraulic System 3	2B (AC)	RIB aileron ultimate backup
Hydraulic System 3	2B (AC)	RIB Elevator ultimate backup

15 The RIB aileron ultimate backup and RIB elevator ultimate backup are hydraulic actuated in the illustrative embodiment; however, they also can be electrically actuated.

Fig. 9C AECM1C (AECM1 20)

Actuator Power	Control Unit Power	Allocated Surface
Hydraulic System 1	2 (DC)	L/R 3 MFS

Fig. 9C AECM1D (AECM1 20)

Actuator Power	Control Unit Power	Allocated Surface
Hydraulic System 1	1 (DC)	Elevator/LOB actuator
Hydraulic System 1	1 (DC)	Rudder/UP actuator
Hydraulic System 1	1 (DC)	L/R 1 MFS

Fig. 9D AECM2C (AECM2 22)

Actuator Power	Control Unit Power	Allocated Surface
Hydraulic System 2	3 (DC)	Elevator/ROB actuator
Hydraulic System 2	3 (DC)	Rudder/MID actuator
Hydraulic System 2	3 (DC)	L/R 4 MFS

5

Fig. 9D AECM2D (AECM2 22)

Actuator Power	Control Unit Power	Allocated Surface
Hydraulic System 2	1 (DC)	Aileron/LOB actuator
Hydraulic System 2	1 (DC)	Aileron/ROB actuator
Hydraulic System 2	1 (DC)	GRD Spoiler sub-system

Fig. 9E AECM3C (AECM3 24)

Actuator Power	Control Unit Power	Allocated Surface
Hydraulic System 3	2 (DC)	Elevator/RIB actuator
Hydraulic System 3	2 (DC)	Rudder/LO actuator
Hydraulic System 3	2 (DC)	L/R 2 MFS

10 Fig. 9E AECM3D (AECM3 24)

Actuator Power	Control Unit Power	Allocated Surface
Hydraulic System 3	3 (DC)	Elevator/LIB actuator

Hydraulic System 3	3 (DC)	Aileron/RIB actuator
Hydraulic System 3	3 (DC)	Aileron/LIB actuator

In Normal mode operation, fully augmented flight control as described above is achieved through the distributed control surfaces.

In Direct mode, the pilot directly commands control surface position.

5 Stability augmentation and command limiting in pitch and yaw axes are provided in direct mode (in part via pitch and yaw rate feedback). A principle design criteria in this distribution of power and AECM/SMCU control is to ensure that under even severe failure conditions, airplane controllability is maintained at a minimum level such as to allow safe flight. As will be appreciated, the distribution matrix provides fault-isolated, fault tolerant, fail-safe and fail-operational functionality without loss of ability to safely control the aircraft.

The present invention has been illustrated and described with respect to specific embodiments thereof, which embodiments are merely illustrative of the principles of the invention and are not intended to be exclusive or otherwise limiting embodiments. For instance, although the description provided hereinabove along with the accompanying drawings illustrate particular embodiments incorporating one or a few features of the present invention, those skilled in the art will understand in view of the hereinabove disclosure that alternative configurations can be devised and implemented, as well as other designs capable of achieving the purpose and benefits of the discussed aspects of the invention.

Accordingly, although the above description of illustrative embodiments of the present invention, as well as various illustrative modifications and features thereof, provides many specificities, these enabling details should not be construed as limiting the scope of the invention, and it will be readily understood by those persons skilled in the art that the present invention is susceptible to many modifications, adaptations, variations, omissions, additions, and equivalent implementations without departing from this scope

and without diminishing its attendant advantages. It is further noted that the terms and expressions have been used as terms of description and not terms of limitation. There is no intention to use the terms or expressions to exclude any equivalents of features shown and described or portions thereof. It is therefore intended that the present invention is not
5 limited to the disclosed embodiments but should be defined in accordance with the claims that follow.

What is claimed is:

1. A multi-axis fly-by-wire flight control system that generates flight surface commands to control the movement of a set of flight control surfaces to control the pitch, roll or yaw directional axes of an aircraft, the system comprising:
 - 5 (A) a plurality of input controls each capable of generating a signal indicative of a commanded position of a corresponding control; and
 - (B) a single flight control channel comprising:
 - (a) a plurality of control paths, each control path controlling a different subset of the set of flight control surfaces, each control path including:
 - 10 (i) at least one servo loop assigned to said control path of the single flight control channel, said at least one servo loop controlling the movement of at least one predetermined flight control surface such that the at least one servo loop in said control path operates to control the aircraft in at least one of the roll, pitch or yaw directional axes;
 - 15 (ii) at least one flight control surface controller configured to receive at least one of the signals and coupled to said at least one servo loop; and
 - (b) a plurality of flight control computers coupled to the at least one flight control surface controller of each control path, which flight control computers each generate flight surface commands according to predetermined flight control algorithms in part as a
 - 20 function of the signals generated by the plurality of input controls.
2. The multi-axis fly-by-wire flight control system according to claim 1, wherein the at least one flight control surface controller is an actuator control module that controls the subset of the set of flight control surfaces to adjust an attitude of the aircraft in the roll, pitch and/or yaw axes.
3. The multi-axis fly-by-wire flight control system according to claim 1 or claim 2, wherein each
 - 25 control path includes a plurality of flight control surface controllers which each are actuator control modules, each actuator control module comprising at least two submodules.
4. The multi-axis fly-by-wire flight control system according to claim 3, wherein one of said actuator control modules is capable of controlling the subset of the set of flight control surfaces

sufficient to comprehensively control the aircraft by adjusting the attitude of the aircraft in the roll, pitch and yaw axes.

- 5 5. The multi-axis fly-by-wire flight control system according to claim 3, wherein each one of said actuator control modules is capable of controlling the subset of the set of flight control surfaces sufficient to adjust the attitude of the aircraft in the roll, pitch or yaw axes, and the plurality of flight control surface controllers further include at least one servo motor control unit which controls the subset of the set of flight control surfaces to control a horizontal stabilizer trim, such that comprehensive control of the aircraft is achieved by each actuator control module in combination with the at least one servo motor control unit.
- 10 6. The multi-axis fly-by-wire flight control system according to claim 2, wherein said actuator control module is capable of controlling the subset of the set of flight control surfaces sufficient to comprehensively control the aircraft in all axes.
- 15 7. The multi-axis fly-by-wire flight control system according to claim 2 or claim 6, wherein the at least one flight control surface controller further includes at least one servo motor control unit which controls a horizontal stabilizer trim, such that comprehensive control of the aircraft is achieved by the actuator control module in combination with the at least one servo motor control unit.
- 20 8. The multi-axis fly-by-wire flight control system according to claim 1, wherein the at least one flight control surface controller is a servo motor control unit which controls a horizontal stabilizer trim.
9. The multi-axis fly-by-wire flight control system according to claim 1, wherein, in the event that an active primary one of the plurality of flight control computers is determined invalid, another of said plurality of flight control computers becomes the active primary flight control computer.
- 25 10. The multi-axis fly-by-wire flight control system according to claim 9, wherein said active primary flight control computer is determined invalid via self test.

11. The multi-axis fly-by-wire flight control system according to claim 3, wherein when every one of said plurality of flight control computers is not engaged, said actuator control modules are commanded according to predetermined flight control algorithms for direct mode operation in response to the signals.

5 12. The multi-axis fly-by-wire flight control system according to claim 3, wherein a first hardware of one of the at least two submodules is at least partially dissimilar to a second hardware of the other one of the at least two submodules.

13. The multi-axis fly-by-wire flight control system according to claim 3, wherein only one of said actuator control modules is capable of controlling the subset of the set of flight control
10 surfaces sufficient to comprehensively control the aircraft in all axes.

14. The multi-axis fly-by-wire flight control system according to claim 1, wherein each control path includes a plurality of servo motor control units.

15. The multi-axis fly-by-wire flight control system according to claim 14, wherein a first hardware of each of the plurality of servo motor control units is at least partially dissimilar to a
15 second hardware of other ones of the plurality of servo motor control units.

16. A multi-axis fly-by-wire flight control system that generates flight surface commands to control the movement of a set of flight control surfaces to control the pitch, roll or yaw directional axes of an aircraft, the system comprising:

(A) a plurality of cockpit controls each capable of generating a signal indicative of a
20 commanded position of a corresponding control; and

(B) a single flight control channel comprising:

(a) a plurality of control paths, each control path controlling a different subset of the set of flight control surfaces,

(i) at least one of said plurality of control paths including:

25 1. a first set of servo loops assigned to said control path of the single flight control channel, said first set of servo loops controlling the movement of a plurality of predetermined flight control surfaces such that the first set of servo loops in said

control path operates to control the aircraft in at least one of the roll, pitch or yaw directional axes;

2. a first flight control surface controller configured to receive at least one of the signals generated by the plurality of cockpit controls and coupled to said first set of servo loops, said first flight control surface controller comprising at least one

actuator control module, said at least one actuator control module comprising at least two (2) submodules and controlling the subset of the set of flight control surfaces to adjust an attitude of the aircraft in the roll, pitch and/or yaw axes,

(ii) at least another of said plurality of control paths including:

1. a second set of servo loops assigned to said control path of the single flight control channel, said second set of servo loops controlling the movement of a plurality of predetermined flight control surfaces such that the second set of servo loops in said control path operates to control the aircraft in at least one of the roll, pitch or yaw directional axes;

2. a second flight control surface controller configured to receive at least one of the signals and coupled to said second set of servo loops, said second flight control surface controller comprising at least one servo motor control unit which controls the subset of the set of flight control surfaces to control a horizontal stabilizer trim, such that comprehensive control of the aircraft is achieved by the at least one actuator control module in combination with the at least one servo motor control unit and

(b) a plurality of flight control computers coupled to the first and the second flight control surface controller of the at least one of said plurality of control paths, which plurality of flight control computers each generate flight surface commands according to predetermined flight control algorithms in part as a function of the signals, only one of said plurality of flight control computers is an active primary flight control computer at any given time, the remaining ones of said plurality of flight control computers running in standby,

wherein a first hardware of one of the at least two submodules is at least partially dissimilar to a second hardware of the other one of the at least two submodules and a third hardware of each of the at least one servo motor control unit is at least partially dissimilar to a fourth hardware of

others of the at least one servo motor control unit and to the first and second hardware of the submodules, and

wherein, in the event that said active primary flight control computer is determined invalid via self test, another one of said plurality of flight control computers becomes the active primary flight control computer, and when every one of said plurality of flight control computers is not engaged, said first and second flight control surface controllers are commanded according to predetermined flight control algorithms for direct mode operation in response to the signals.

17. A method of individually controlling the position of a set of flight control surfaces on an aircraft through a single flight control channel that comprises a plurality of control paths, each control path controlling a different subset of the set of flight control surfaces, said method comprising:

- (a) providing signals indicative of a command from at least one of a plurality of cockpit controls to each of a plurality of flight control computers in said single flight control channel via at least one flight control surface controller configured to receive at least one of the signals, which plurality of flight control computers are each capable of generating flight surface commands according to predetermined flight control algorithms as a function of the signals;
- (b) designating only one flight control computer of said plurality of flight control computers as a primary flight computer for said single flight control channel, with other ones of said plurality of flight control computers running in a standby mode;
- (c) transmitting said flight surface commands from the primary flight control computer along at least one of said plurality of control paths to the at least one flight control surface controller that is coupled to at least one servo loop assigned to said at least one control path; and
- (d) controlling a movement of at least one of the set of flight control surfaces via said at least one flight control surface controller coupled to said at least one servo loop; such that the at least one servo loop in said at least one control path operates to control the aircraft in at least one of the roll, pitch or yaw directional axes.

18. The method of claim 17, wherein only the flight surface commands from the primary flight control computer are transmitted to the at least one flight control surface controller.

19. The method of claim 17, wherein the at least one flight control surface controller receives only the flight surface commands transmitted by the primary flight control computer.

20. A method of controlling the position of a plurality of flight control surfaces on an aircraft comprising:

- 5 (a) providing signals indicative of a commanded position;
- (b) transmitting the signals to a plurality of flight control computers, which are each capable of generating flight surface commands as a function of the signals;
- (c) selecting one flight control computer of said plurality of flight control computers as a primary flight computer, with the others of said plurality of flight control computers
10 remaining in a standby mode;
- (d) transmitting, in a single channel having a multiplicity of control paths, said flight surface commands from the primary flight control computer to a flight control surface controller in each of said multiplicity of control paths with each control path controlling a different subset of the plurality of flight control surfaces; and
- 15 (e) applying the flight surface commands via said flight control surface controller to a plurality of servo loops to control a corresponding set of the plurality of flight control surfaces on the aircraft.

21. A multi-axis fly-by-wire flight control system that generates flight surface commands to control the movement of a set of flight control surfaces to control the pitch, roll or yaw
20 directional axes of an aircraft, the system comprising:

(A) a plurality of input controls each capable of generating a signal indicative of a commanded position of a corresponding control; and

(B) a single flight control channel comprising:

25 (a) a plurality of control paths, each one of the plurality of control paths controlling a different subset of the set of flight control surfaces, each control path including:

(i) at least one servo loop assigned to said control path of the single flight control channel, said at least one servo loop controlling the movement of at least one predetermined flight control surface such that the at least one servo loop in

said control path operates to control the aircraft in at least one of the roll, pitch or yaw directional axes;

(ii) a plurality of flight control surface controllers configured to receive at least one of the signals generated by the plurality of input controls and coupled to said at least one servo loop; and

(b) a plurality of flight control computers coupled to the plurality of flight control surface controllers of each control path, which flight control computers each generate flight surface commands according to predetermined flight control algorithms in part as a function of the signals, only one of said plurality of flight control computers is an active primary flight control computer at any given time, the remaining flight control computers of said plurality of flight control computers running in standby,

wherein the plurality of flight control surface controllers are each actuator control modules, each actuator control module comprising at least two submodules, and wherein each of the plurality of flight control surface controllers controls the subset of the set of flight control surfaces to adjust an attitude of the aircraft in the roll, pitch and/or yaw axes, and wherein a first hardware of the one of the at least two submodules is at least partially dissimilar to a second hardware of the other one of the at least two submodules.

22. A multi-axis fly-by-wire flight control system that generates flight surface commands to control the movement of a set of flight control surfaces to control the pitch, roll or yaw directional axes of an aircraft, the system comprising:

(A) a plurality of input controls each capable of generating a signal indicative of a commanded position of a corresponding control; and

(B) a single flight control channel comprising:

(a) a plurality of control paths, each control path controlling a different subset of the set of flight control surfaces, each control path including:

(i) at least one servo loop assigned to said control path of the single flight control channel, said servo loop controlling the movement of at least one predetermined flight control surface such that the at least one servo loop in said control path operates to control the aircraft in at least one of the roll, pitch or yaw directional axes;

(ii) at least one flight control surface controller configured to receive at least one of the signals generated by the plurality of input controls and coupled to said at least one servo loop; and

5 (b) a plurality of flight control computers coupled to the at least one flight control surface controller of each control path, which flight control computers each generate flight surface commands according to predetermined flight control algorithms in part as a function of the signals, only one of said plurality of flight control computers is an active primary flight control computer at any given time, the remaining flight control computers of said plurality of flight control computers running in standby,

10 wherein each control path includes a plurality of flight control surface controllers which each are actuator control modules, each actuator control module comprising at least two submodules, wherein the actuator control module controls the subset of the set of flight control surfaces to adjust an attitude of the aircraft in the roll, pitch and/or yaw axes, and wherein only one of the actuator control modules is capable of controlling the subset of the set of flight control surfaces
15 sufficient to comprehensively control the aircraft in all axes.

23. A multi-axis fly-by-wire flight control system that generates flight surface commands to control the movement of a set of flight control surfaces to control the pitch, roll or yaw directional axes of an aircraft, the system comprising:

20 (A) a plurality of input controls each capable of generating a signal indicative of a commanded position of a corresponding control; and

(B) a single flight control channel comprising:

(a) a plurality of control paths that each include a plurality of servo motor control units, each control path controlling a different subset of the set of flight control surfaces, each control path including:

25 (i) at least one servo loop assigned to said control path of the single flight control channel, said at least one servo loop controlling the movement of at least one predetermined flight control surface such that the at least one servo loop in said control path operates to control the aircraft in at least one of the roll, pitch or yaw directional axes;

(ii) at least one flight control surface controller configured to receive at least one of the signals generated by the plurality of input controls and coupled to said at least one servo loop; and

5 (b) a plurality of flight control computers coupled to the at least one flight control surface controller of each control path, which flight control computers each generate flight surface commands according to predetermined flight control algorithms in part as a function of the signals, only one of said plurality of flight control computers is an active primary flight control computer at any given time, the remaining computers of said plurality running in standby; and

10 wherein a first hardware of each of the plurality of servo motor control units is at least partially dissimilar to a second hardware of the others of the plurality of servo motor control units.

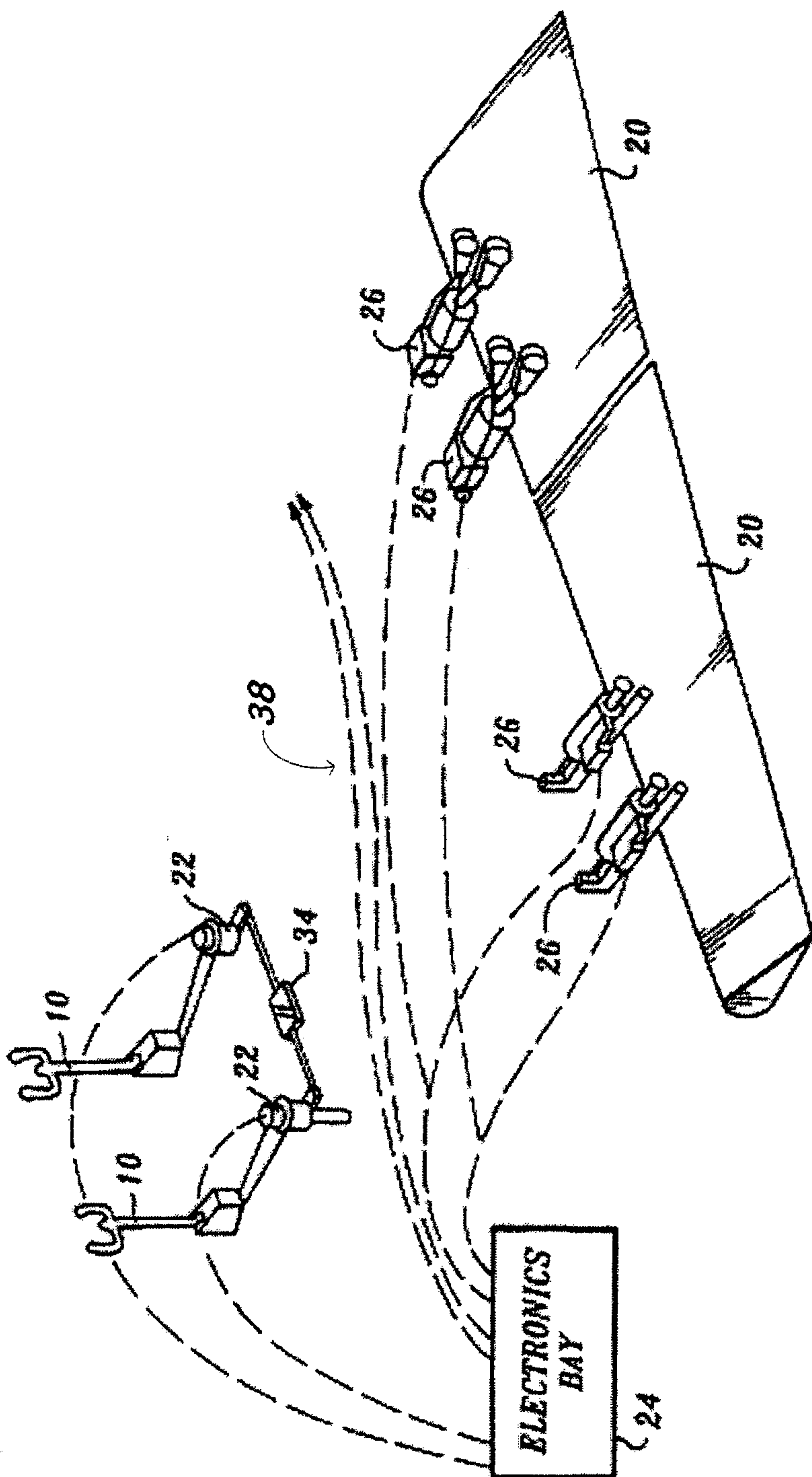

Fig. 1
-prior art-

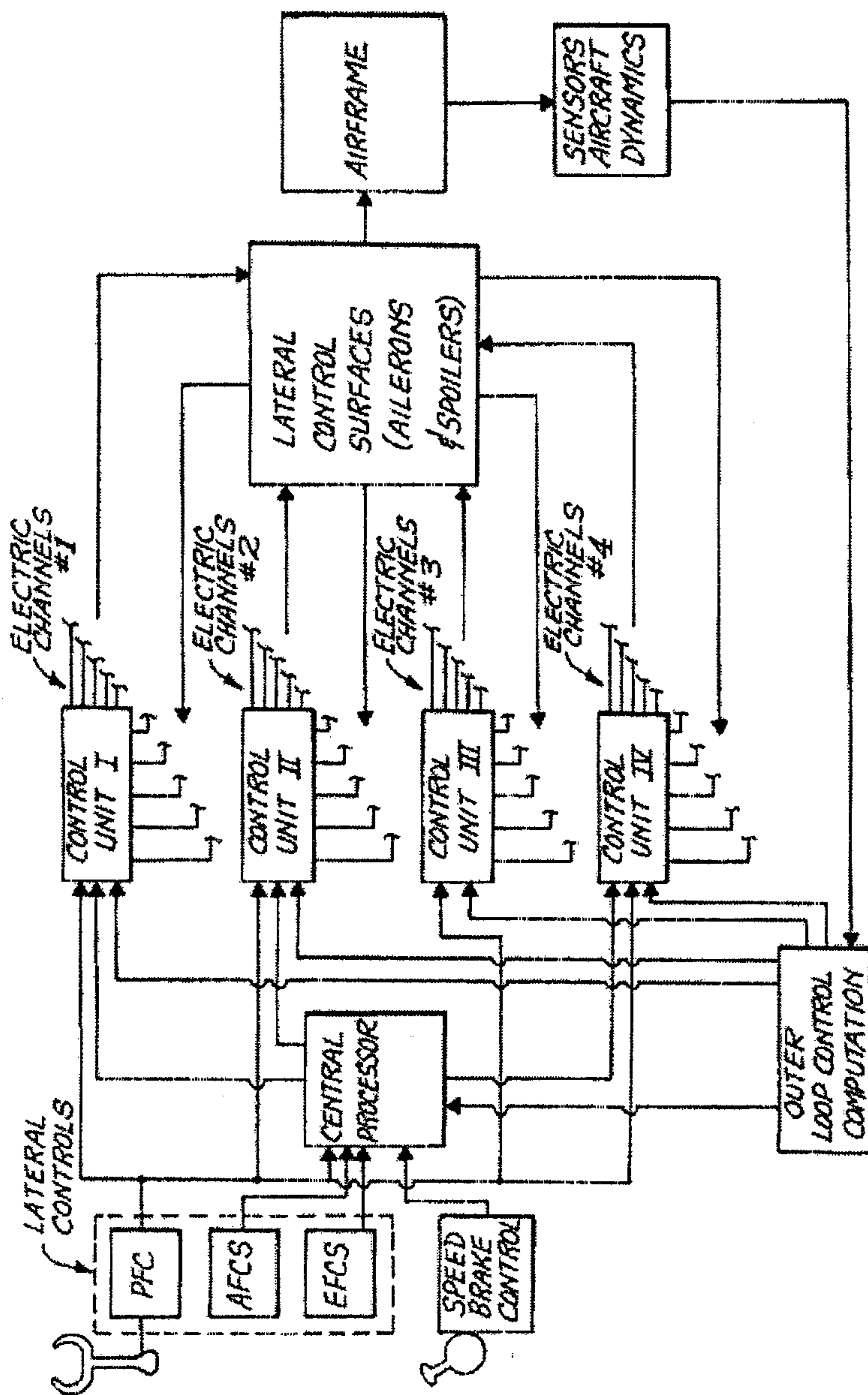

Fig. 2
-prior art-

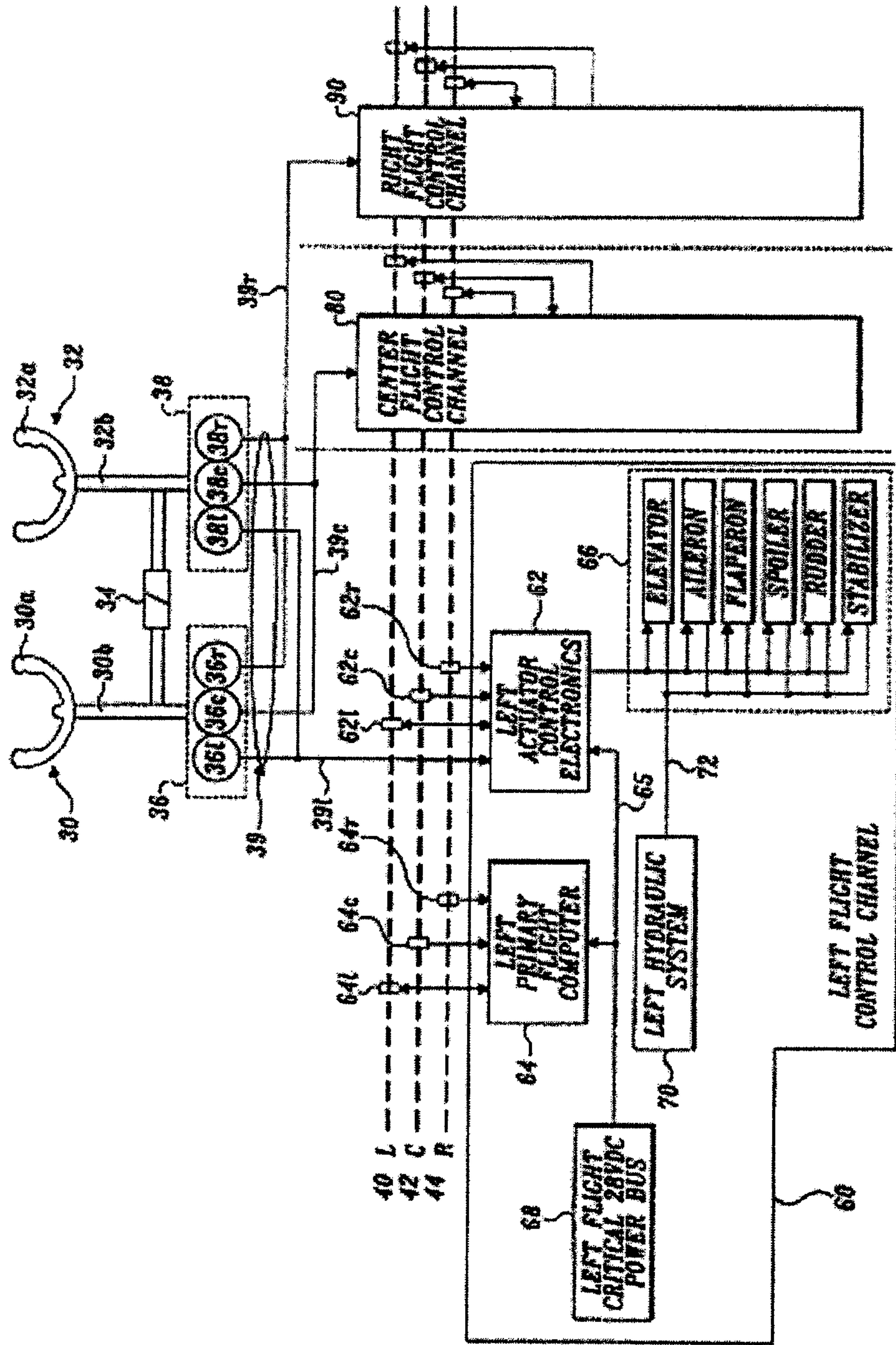

Fig. 3
-prior art-

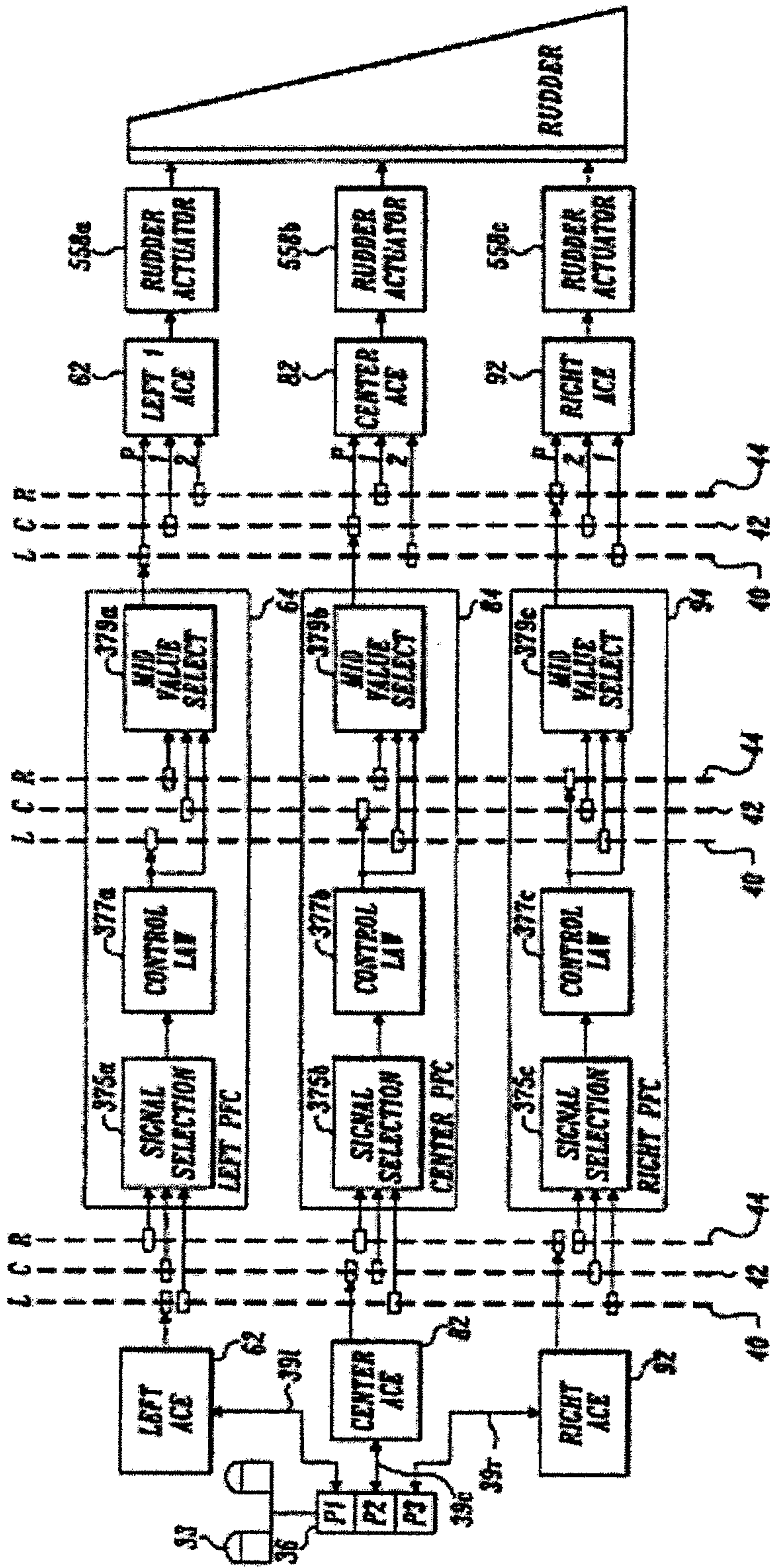

Fig. 4
-prior art-

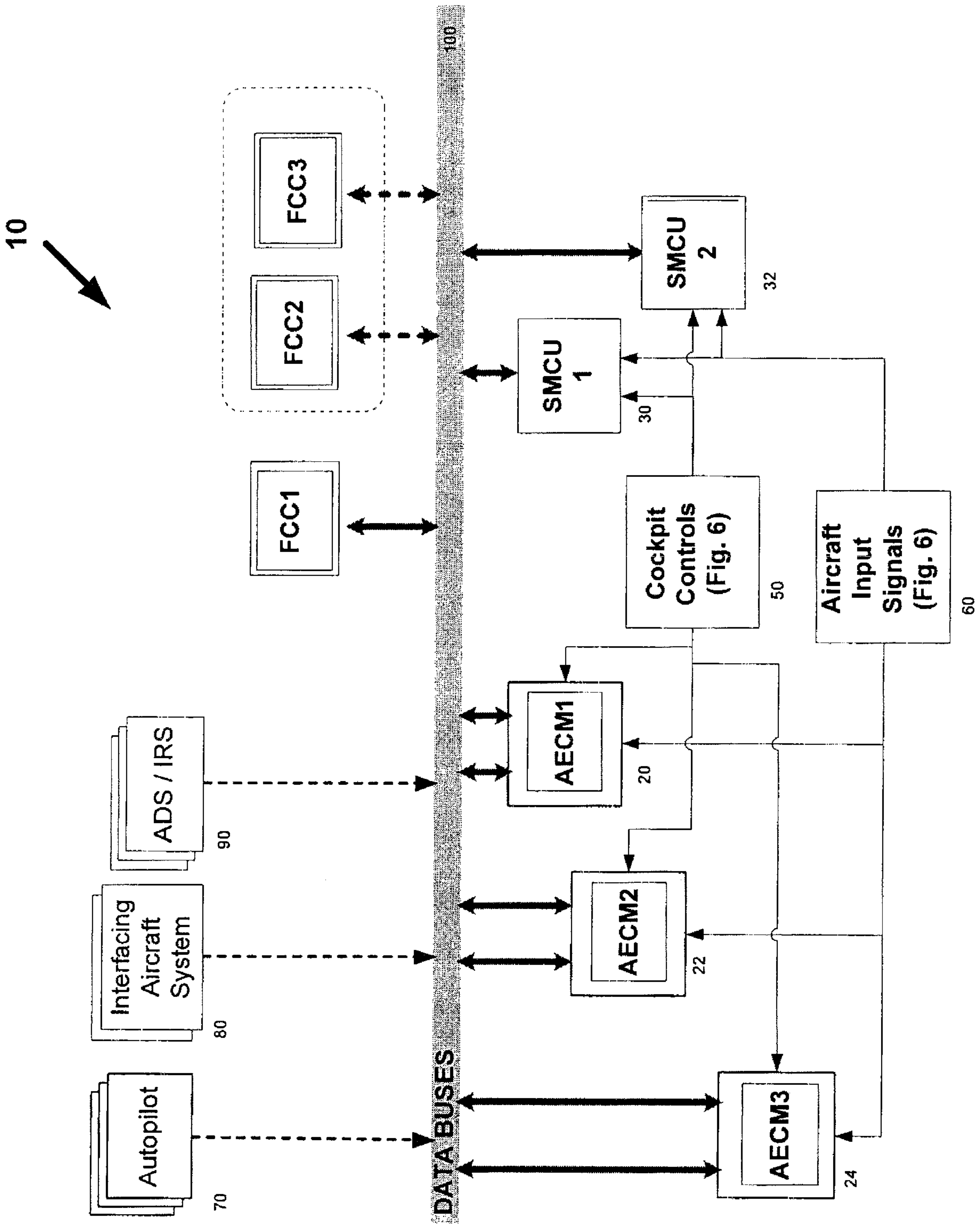

Fig. 5

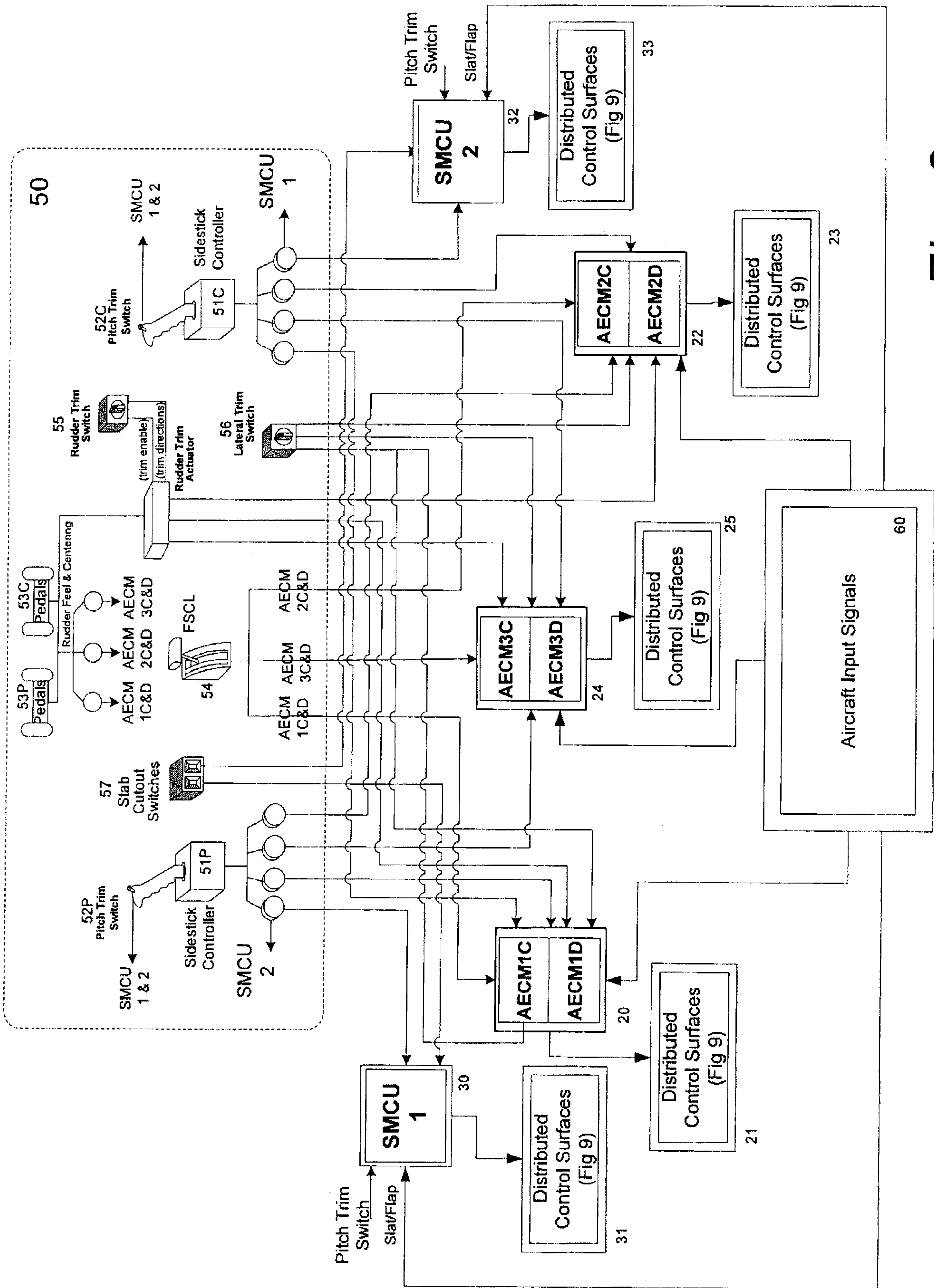

Fig. 6

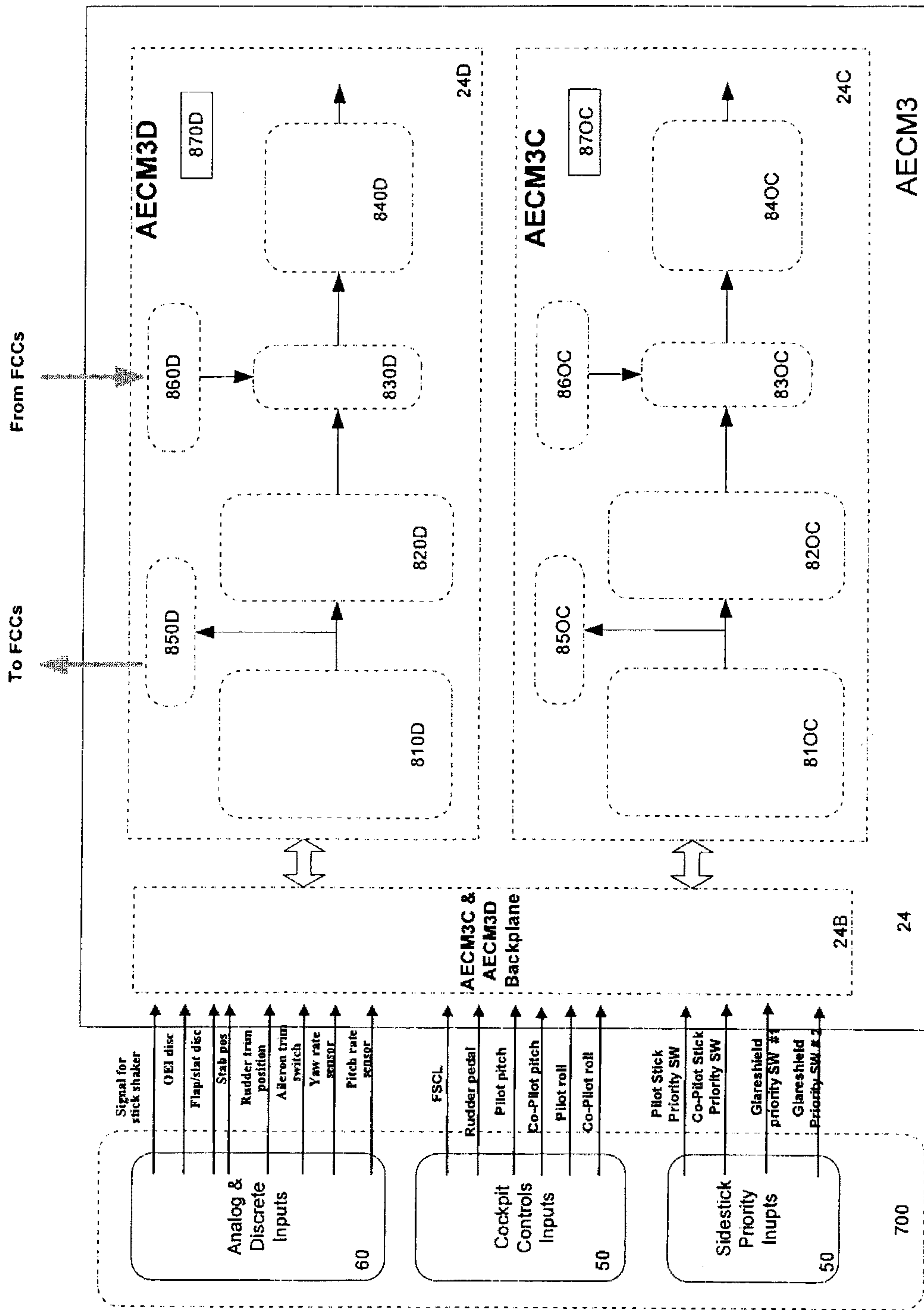

Fig. 7

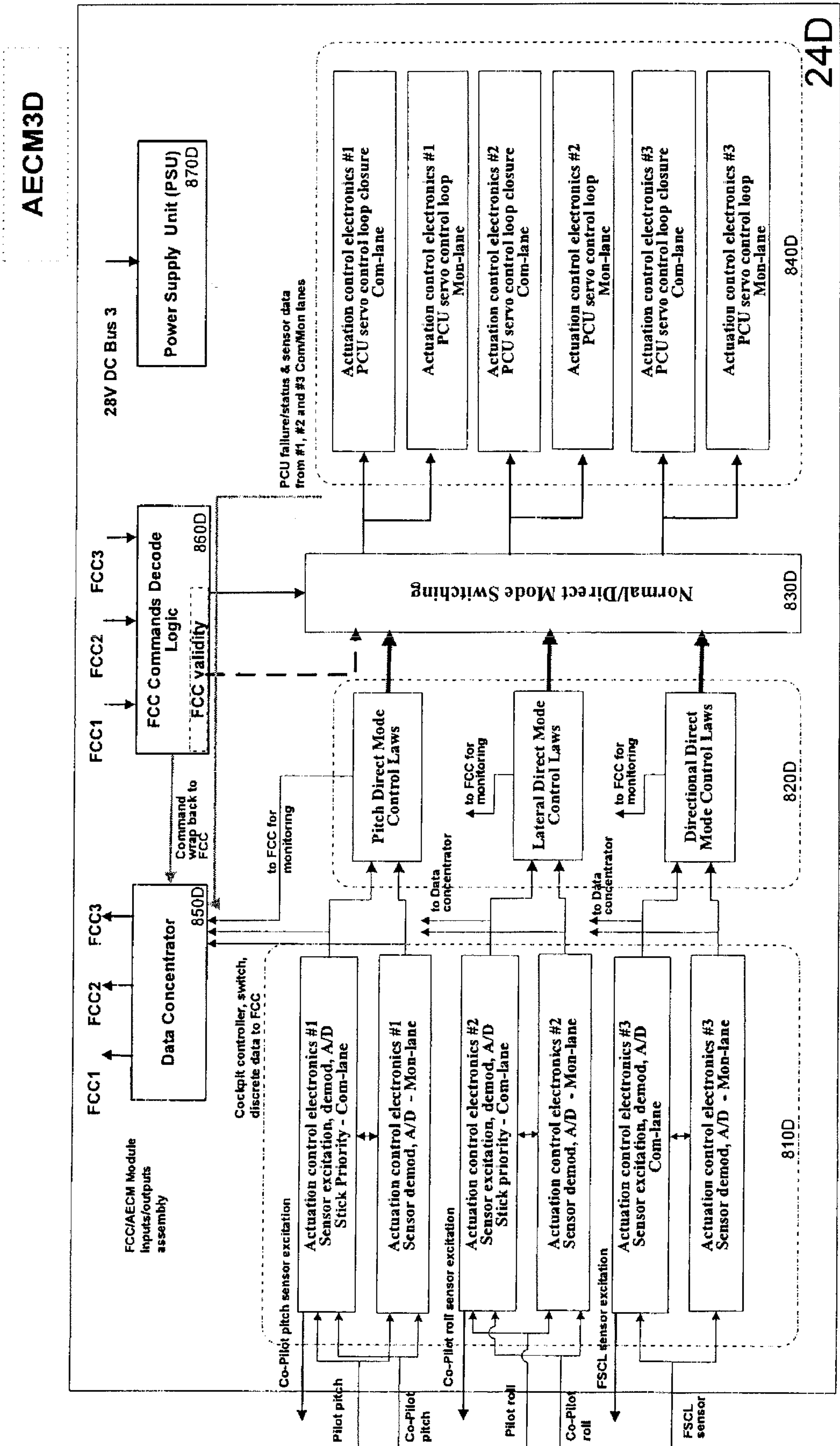
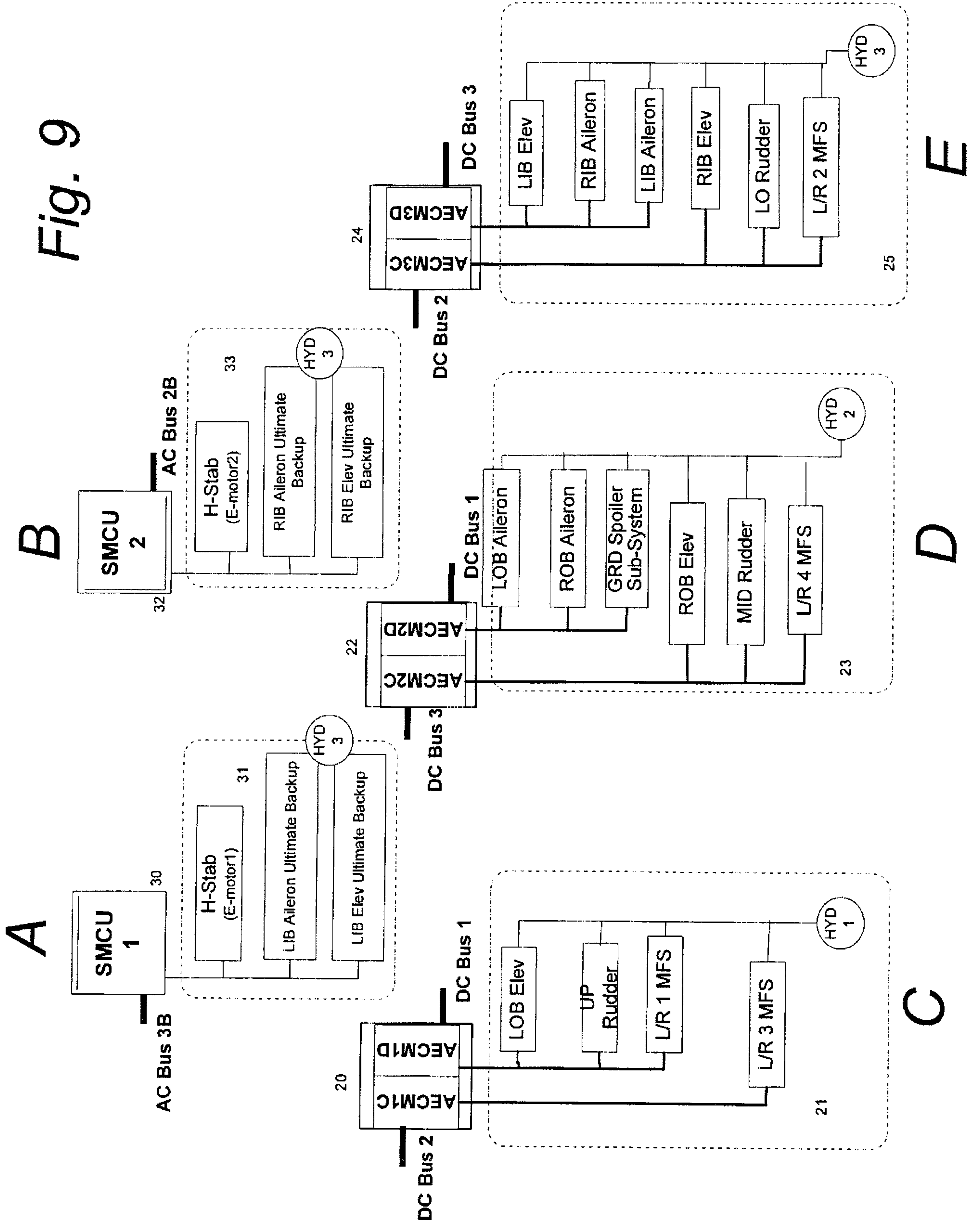
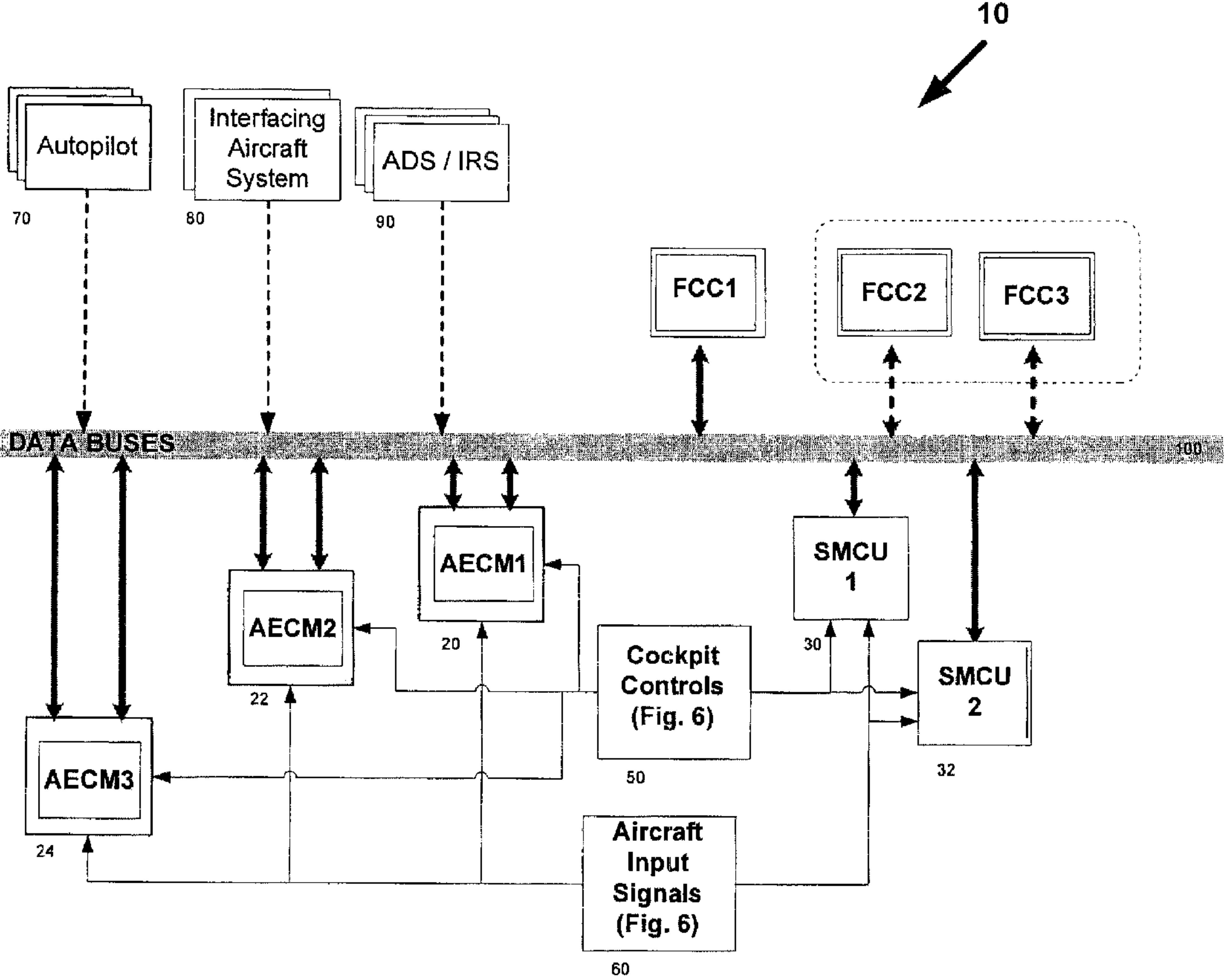

Fig. 8

Fig. 9





10

Autopilot

70

Interfacing Aircraft System

80

ADS / IRS

90

FCC1

FCC2

FCC3

DATA BUSES

100

AECM1

20

AECM2

22

AECM3

24

Cockpit Controls (Fig. 6)

50

Aircraft Input Signals (Fig. 6)

60

SMCU 1

30

SMCU 2

32