



US 20080210557A1

(19) **United States**  
(12) **Patent Application Publication**  
**HELLER et al.**

(10) **Pub. No.: US 2008/0210557 A1**  
(43) **Pub. Date: Sep. 4, 2008**

(54) **SUBCUTANEOUS GLUCOSE ELECTRODE**

(75) Inventors: **Adam HELLER**, Austin, TX (US);  
**Michael V. Pishko**, Austin, TX (US)

Correspondence Address:  
**SUGHRUE MION, PLLC**  
**2100 PENNSYLVANIA AVENUE, N.W., SUITE 800**  
**WASHINGTON, DC 20037 (US)**

(73) Assignee: **ABBOTT LABORATORIES**,  
Abbott Park, IL (US)

(21) Appl. No.: **12/039,576**

(22) Filed: **Feb. 28, 2008**

**Related U.S. Application Data**

(63) Continuation of application No. 11/695,612, filed on Apr. 3, 2007, which is a continuation of application No. 11/109,379, filed on Apr. 19, 2005, which is a continuation of application No. 10/353,341, filed on Jan. 28, 2003, now Pat. No. 6,881,551, which is a continuation of application No. 09/997,808, filed on Nov. 29, 2001, now Pat. No. 6,514,718, which is a continuation of application No. 09/668,221, filed on Sep. 22, 2000, now Pat. No. 6,329,161, which is a continuation of application No. 09/477,053, filed on Jan. 3, 2000, now Pat. No. 6,162,611, which is a con-

tinuation of application No. 09/356,102, filed on Jul. 16, 1999, now Pat. No. 6,121,009, which is a continuation of application No. 08/767,110, filed on Dec. 4, 1996, now Pat. No. 6,284,478, which is a continuation of application No. 08/299,526, filed on Sep. 1, 1994, now Pat. No. 5,593,852, which is a continuation-in-part of application No. 08/161,682, filed on Dec. 2, 1993, now Pat. No. 5,356,786, which is a continuation of application No. 07/664,054, filed on Mar. 4, 1991, now abandoned.

**Publication Classification**

(51) **Int. Cl.**  
**G01N 27/26** (2006.01)  
**D06M 10/00** (2006.01)  
(52) **U.S. Cl.** ..... **204/403.01**; 264/465; 424/400  
(57) **ABSTRACT**

A small diameter flexible electrode designed for subcutaneous in vivo amperometric monitoring of glucose is described. The electrode is designed to allow "one-point" in vivo calibration, i.e., to have zero output current at zero glucose concentration, even in the presence of other electroreactive species of serum or blood. The electrode is preferably three or four-layered, with the layers serially deposited within a recess upon the tip of a polyamide insulated gold wire. A first glucose concentration-to-current transducing layer is overcoated with an electrically insulating and glucose flux limiting layer (second layer) on which, optionally, an immobilized interference-eliminating horseradish peroxidase based film is deposited (third layer). An outer (fourth) layer is biocompatible.

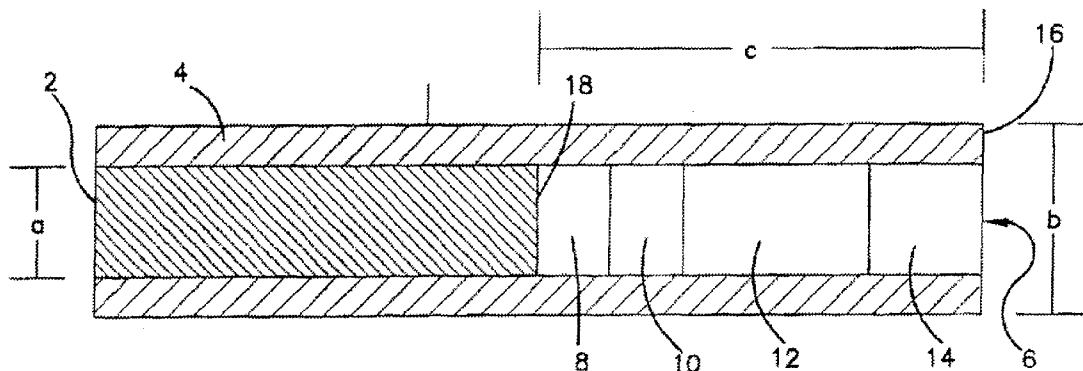

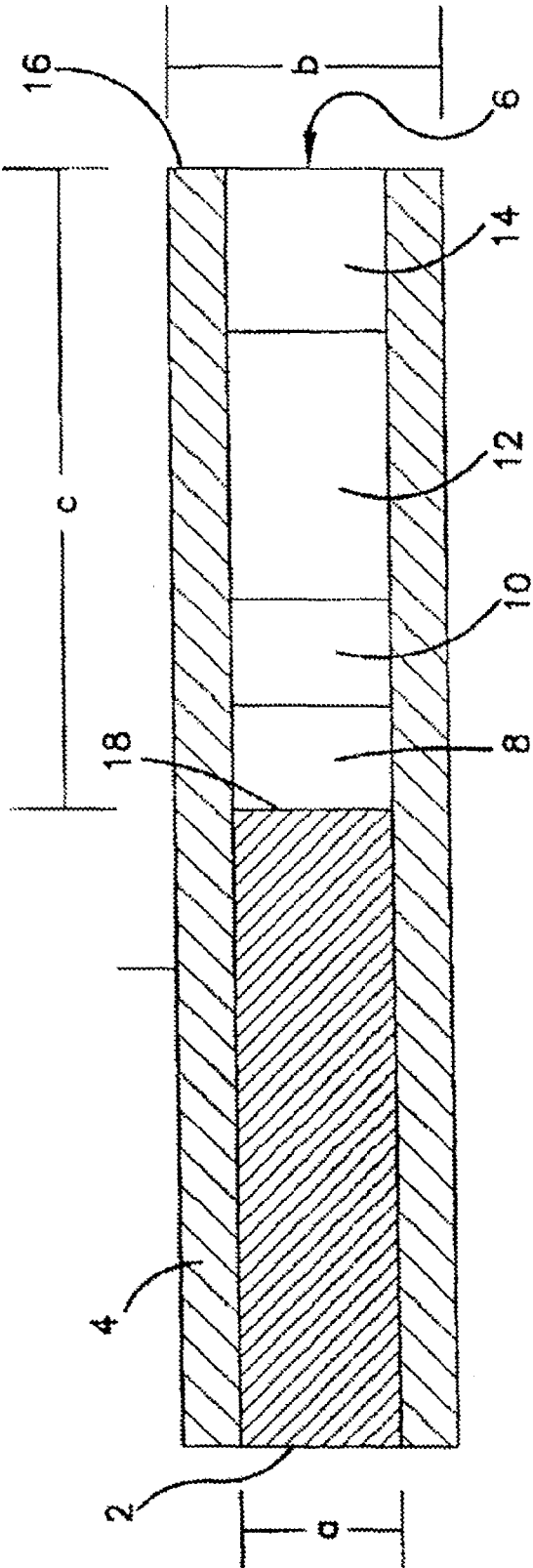

FIG. 1

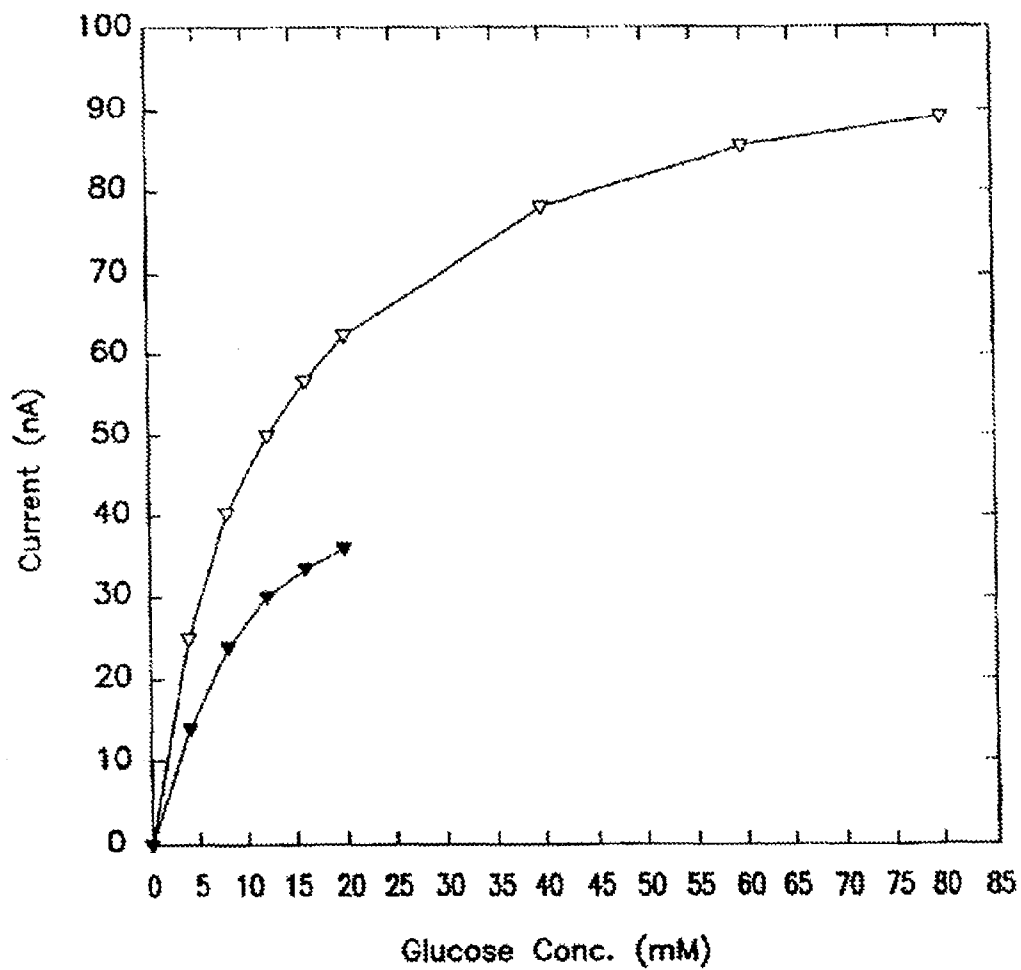

FIG. 2

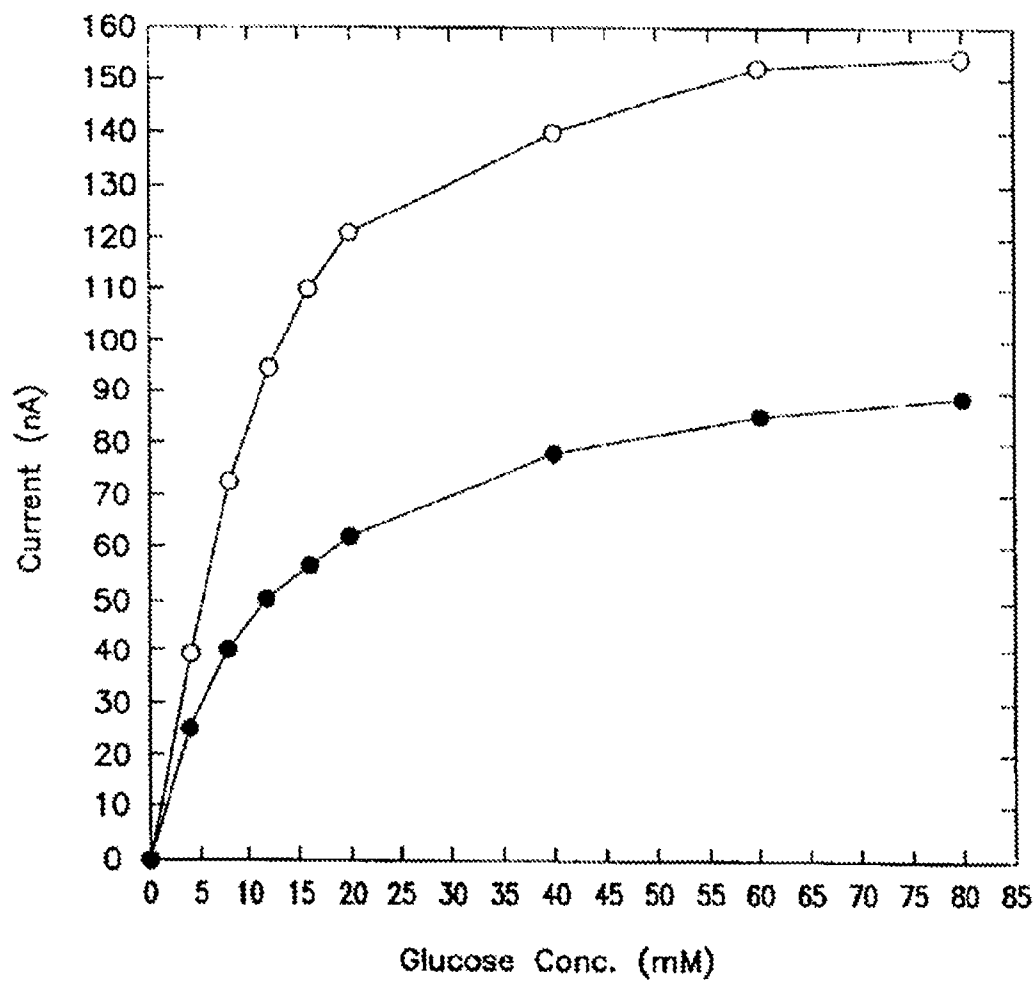

FIG. 3

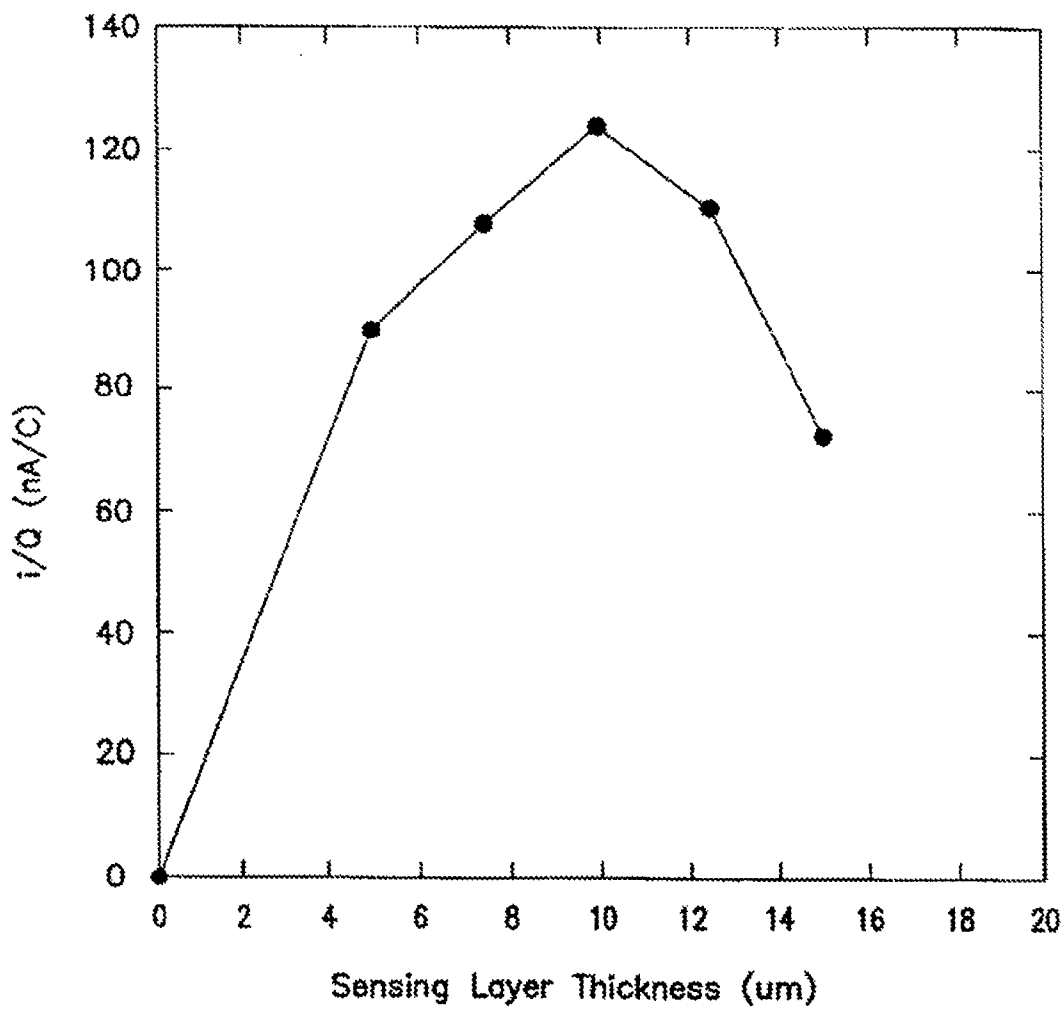

FIG. 4

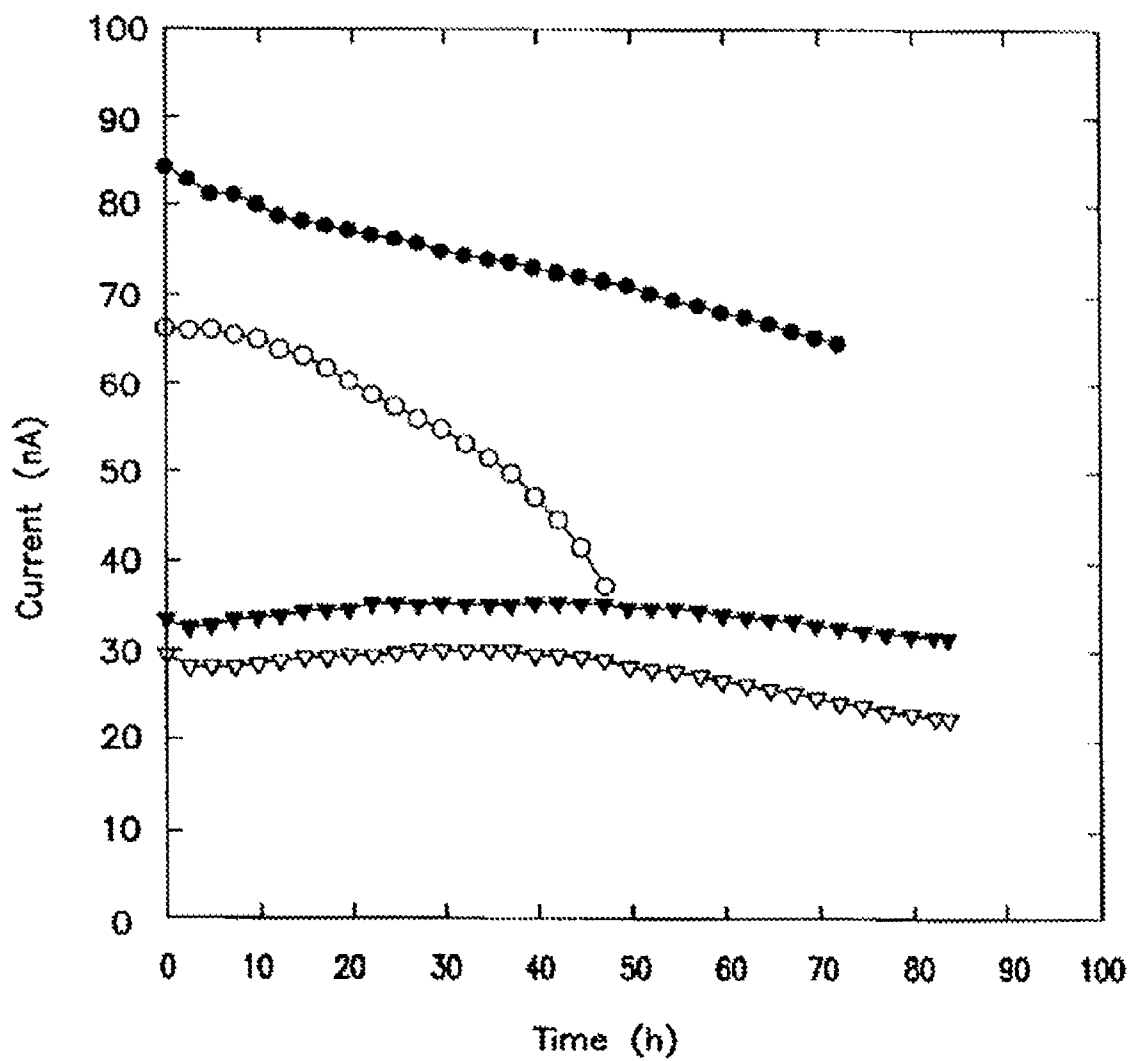

FIG. 5

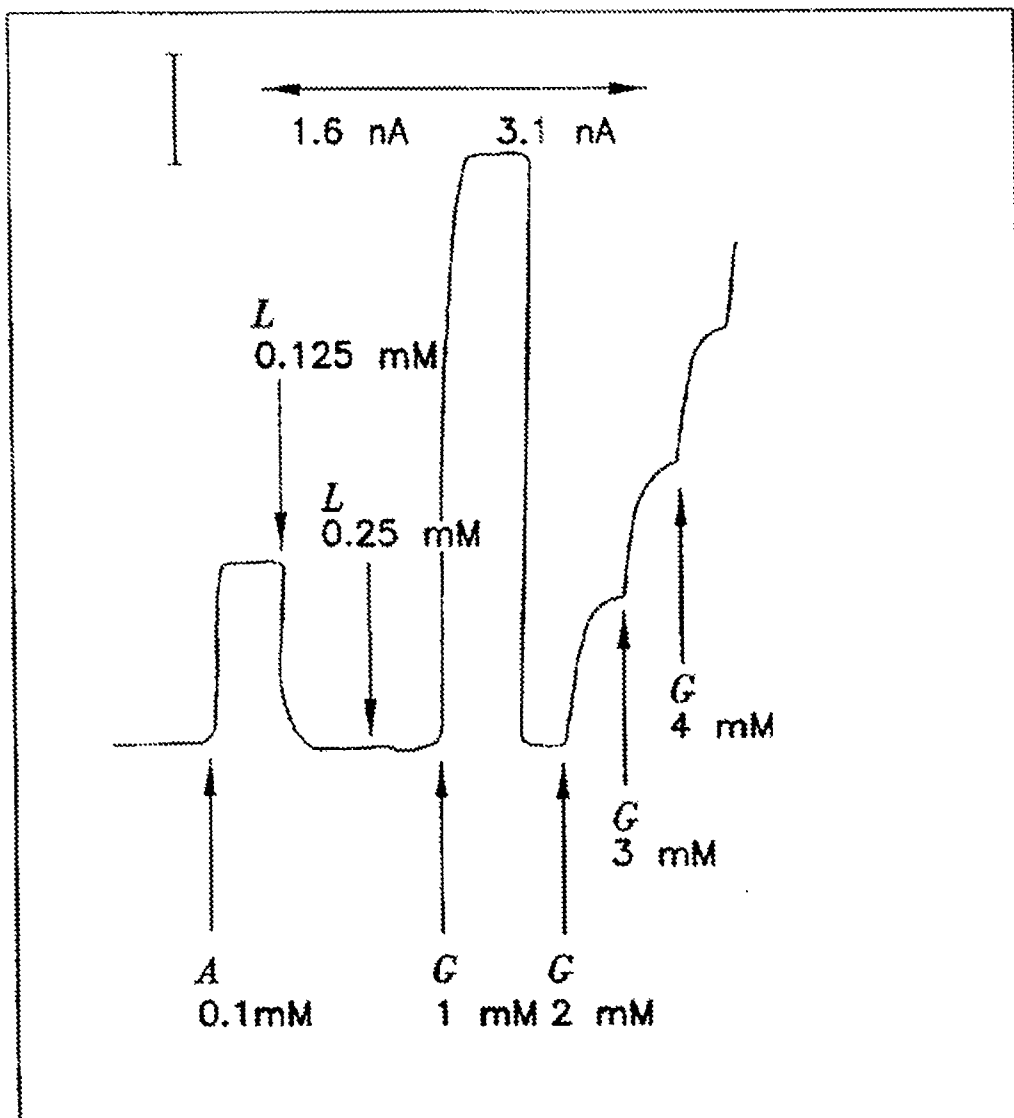

FIG. 6

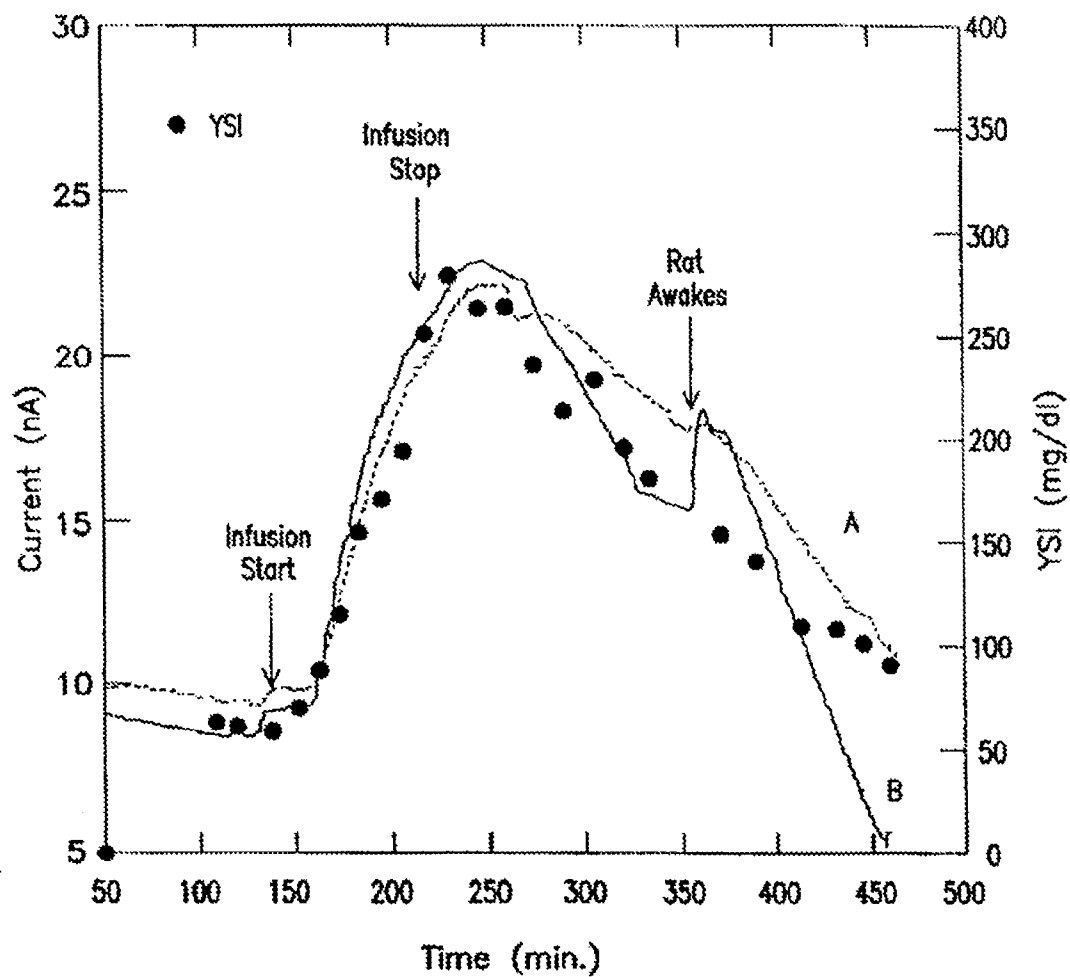

FIG. 7



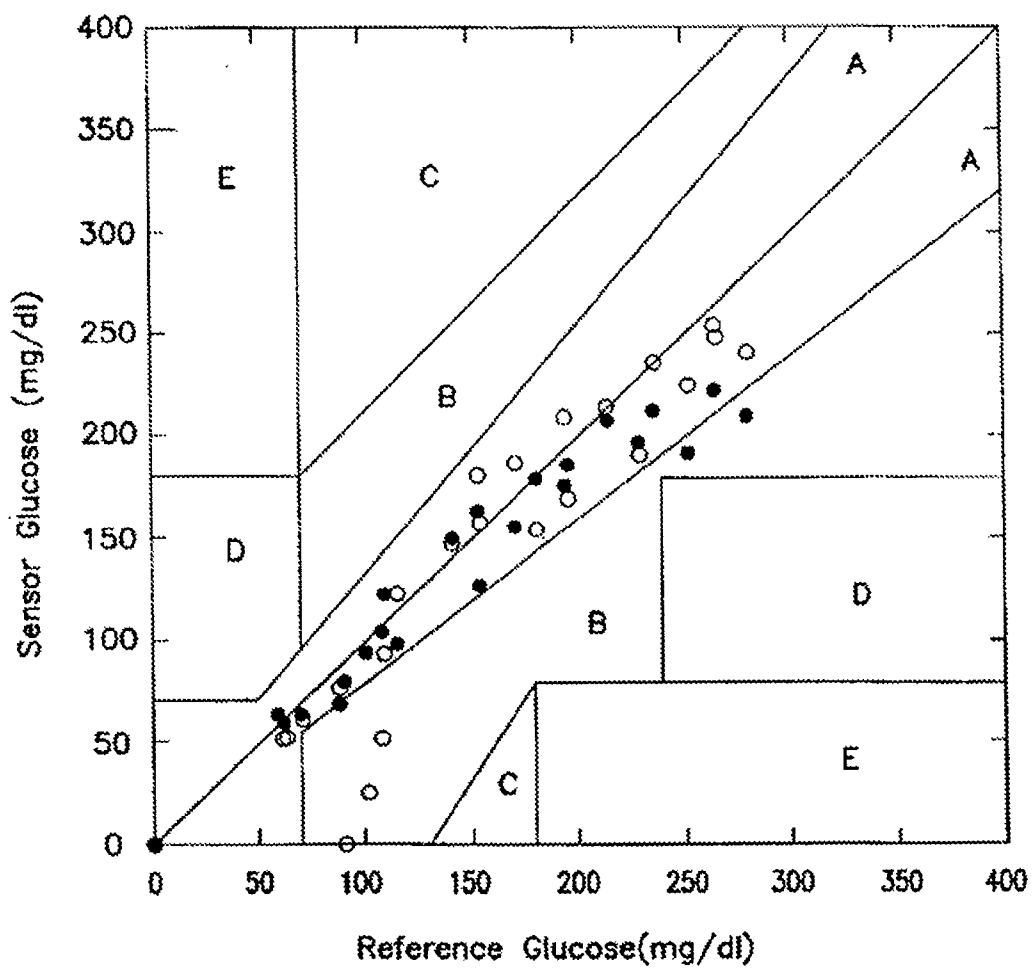

FIG. 8

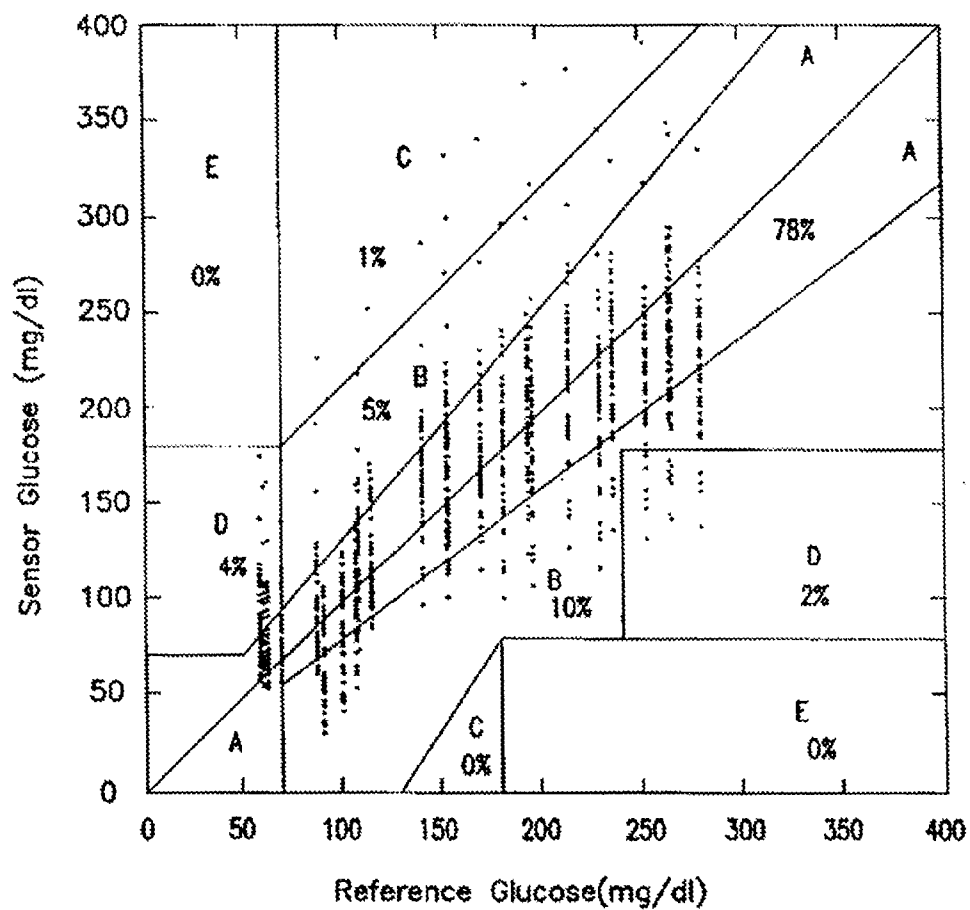

FIG. 9

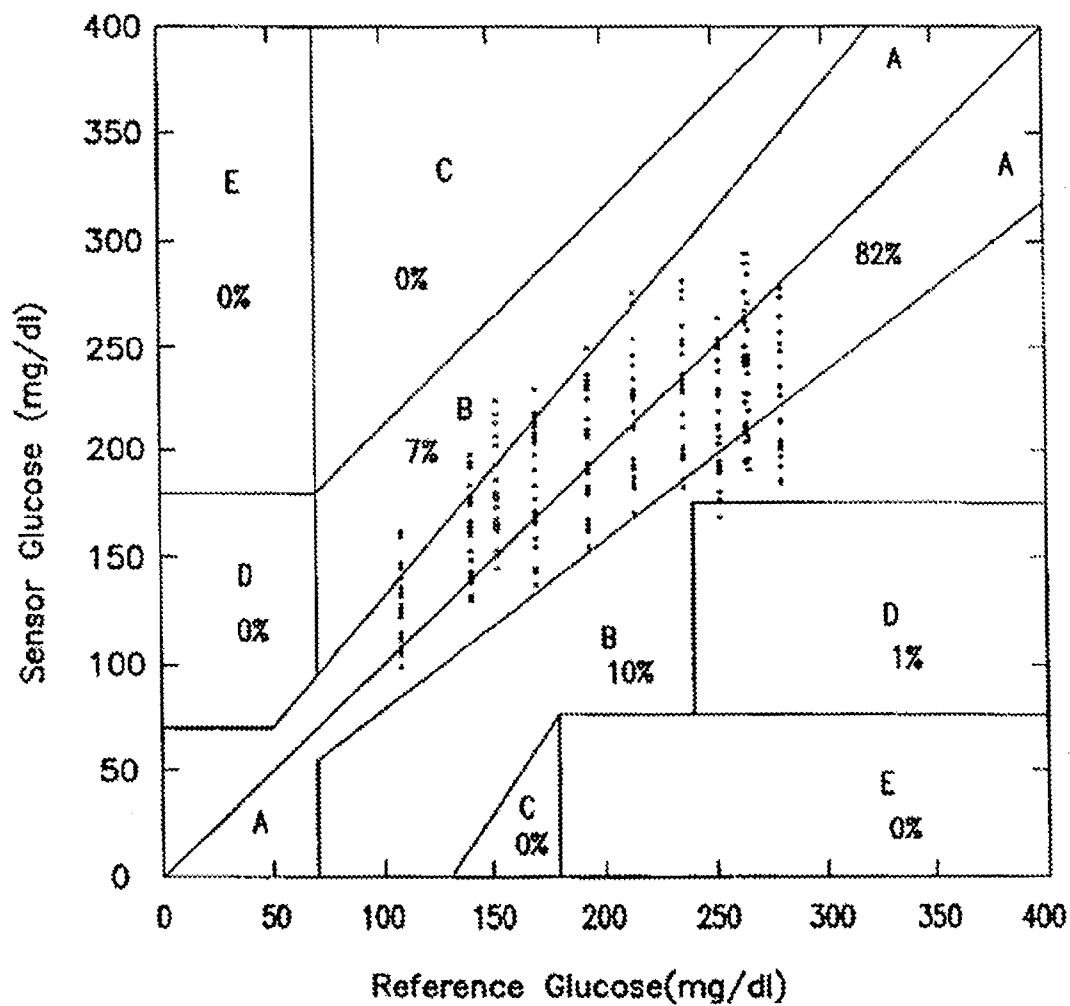

FIG. 10

## SUBCUTANEOUS GLUCOSE ELECTRODE

### CROSS-REFERENCE TO RELATED APPLICATIONS

**[0001]** This application is a Continuation of application Ser. No. 11/109,379, filed on Apr. 19, 2005, which is a Continuation application of Ser. No. 10/353,341, filed Jan. 28, 2003, now U.S. Pat. No. 6,881,551, which is a Continuation application of Ser. No. 09/997,808, filed Nov. 29, 2001, now U.S. Pat. No. 6,514,718, which is a Continuation application of Ser. No. 09/668,221, filed Sep. 22, 2000, now U.S. Pat. No. 6,329,161, which is a Continuation of application Ser. No. 09/477,053, filed Jan. 3, 2000, now U.S. Pat. No. 6,162,611, which is a Continuation of application Ser. No. 09/356,102, filed Jul. 16, 1999, now U.S. Pat. No. 6,121,009, which is a Continuation of application Ser. No. 08/767,110, filed Dec. 4, 1996, now U.S. Pat. No. 6,284,478, which is a continuation of application Ser. No. 08/299,526, filed Sep. 1, 1994, now U.S. Pat. No. 5,593,852, which is a continuation-in-part of application Ser. No. 08/161,682, filed Dec. 2, 1993, now U.S. Pat. No. 5,356,786, which is a continuation of application Ser. No. 07/664,054, filed Mar. 4, 1991, now abandoned, which applications are incorporated herein by reference.

### STATEMENT REGARDING FEDERALLY SPONSORED RESEARCH OR DEVELOPMENT

**[0002]** This work was supported in part by the National Institutes of Health (DK42015). Accordingly, the U.S. government may have rights in this invention.

### FIELD OF THE INVENTION

**[0003]** The present invention relates to *in vivo* enzyme biosensors and more specifically to miniature glucose sensors for subcutaneous measurement of glucose with one-point calibration.

### BACKGROUND

**[0004]** In response to the need for frequent or continuous *in vivo* monitoring of glucose in diabetics, particularly in brittle diabetes, a range of possible *in vivo* glucose electrodes have been studied. The desired characteristics of these electrodes include safety, clinical accuracy and reliability, feasibility of *in vivo* recalibration, stability for at least one hospital shift of eight hours, small size, ease of insertion and removal, and a sufficiently fast response to allow timely intervention. The *in vivo* recalibration should be based upon withdrawal of a single sample of body fluid, e.g., blood, and measuring its glucose concentration. This is termed "one point calibration".

**[0005]** Keys to safety are absence of leachable components, biocompatibility, and limiting of the potentially hazardous foreign matter introduced into the body to an amount that is inconsequential in a worst case failure. The clinical accuracy must be such that even when the readings are least accurate, the clinical decisions based on these be still correct. Feasibility of prompt confirmation of proper functioning of the sensors and of periodic *in vivo* recalibration is of essence if a physician is to allow the treatment of a patient to depend on the readings of the sensor. This one-point calibration, relying on the signal at zero glucose concentration being zero and measuring the blood glucose concentration at one point in time, along with the signal, is of essence, but has heretofore been elusive. The sensitivity must be sufficiently stable for the frequency of required *in vivo* recalibration to not be exces-

sive. The sensor must be small enough to be introduced and removed with minimal discomfort to the patient and for minimal tissue damage. It is preferred that the sensor be subcutaneous and that it be inserted and removed by the patient or by staff in a physician's office. Finally, its response time must be fast enough so that corrective measures, when needed, can be timely.

**[0006]** In response to some of these needs, needle type and other subcutaneous amperometric sensors were considered. The majority of these utilized platinum-iridium, or platinum black to electrooxidize  $H_2O_2$  generated by the glucose oxidase (GOX) catalyzed reaction of glucose and oxygen. In these sensors, the GOX was usually in large excess and immobilized, often by crosslinking with albumin and glutaraldehyde. To exclude electrooxidizable interferants, membranes of cellulose acetate and sulfonated polymers including Nafion™ were used. Particular attention was paid to the exclusion of the most common electrooxidizable interferants: ascorbate, urate and acetaminophen. Also to cope with the interferants, two-electrode differential measurements were used, one electrode being sensitive to glucose and electrooxidizable interferants and the other only to interferants. One strategy for overcoming the problem of interferants, applicable also to the present invention, involves their preoxidation. Another strategy involves shifting, through chemical changes, the redox potential of the polymer in the sensing layer to more reducing potentials. When the redox potential of the polymer is in the region between about  $-0.15$  V and  $+0.15$  V versus the standard calomel electrode (SCE), and the electrodes are poised in their *in vivo* operation between about  $-0.10$  and  $+0.25$  V, the rate of electrooxidation of interferants such as ascorbate, urate, and acetaminophen is very slow relative to that of glucose through its physiological concentration range. Thus, also the currents from electrooxidation of interferants are small relative to those of glucose.

**[0007]** To make the electrodes more biocompatible, hydrophilic polyurethanes, poly(vinyl alcohol) and polyHEMA membranes have been used.

**[0008]** Several researchers tested GOX-based glucose sensors *in vivo* and obtained acceptable results in rats, rabbits, dogs, pigs, sheep and humans. These studies validated the subcutaneous tissue as an acceptable glucose sensing site. Good correlation was observed between intravascular and subcutaneous glucose concentrations. They also demonstrated the need for *in vivo* sensor calibration. Another approach to *in vivo* glucose monitoring was based on coupling subcutaneous microdialysis with electrochemical detection. To control and adjust the linear response range, electrodes have been made glucose-diffusion limited, usually through glucose transport limiting membranes.

**[0009]** Diffusional mediators, through which the  $O_2$  partial pressure dependence of the signals is reduced, are leached from sensors. Such leaching introduces an unwanted chemical into the body, and also leads to loss in sensitivity, particularly in small sensors. In microsensors, in which outward diffusion of the mediator is radial, the decline in sensitivity is rapid. This problem has been overcome in "wired" enzyme electrodes, i.e., electrodes made by connecting enzymes to electrodes through crosslinked electron-conducting redox hydrogels ("wires"). Glucose oxidase has been "wired" with polyelectrolytes having electron relaying  $[Os(bpy)_2Cl]^{+2+}$  redox centers in their backbones. Hydrogels were formed upon crosslinking the enzyme and its wire on electrodes. These electrodes had high current densities and operated at a

potential of 0.3V vs. SCE. The electrooxidizable interferants are eliminated through peroxidase-catalyzed preoxidation in a second, nonwired, hydrogen peroxide generating layer on the "wired" enzyme electrode.

#### SUMMARY OF THE INVENTION

**[0010]** A small (e.g., 0.29 mm), recessed, non-corroding metal (e.g., gold, platinum, palladium) or carbon wire electrode for subcutaneous in vivo glucose monitoring, approaching in its performance all of the above listed requirements, including in vivo one-point calibration, has been produced. The electrode was constructed by depositing active polymer layers into a recess formed by etching away gold from an insulated gold wire.

**[0011]** The active polymer layers, including a sensing layer, a glucose flux-limiting layer, a biocompatible layer, and optionally a peroxidase-based interferant eliminating layer, were protected within the recess against mechanical damage. (The peroxidase-based interferant eliminating layer is not required when a lower redox potential polymer is used, as described above.) The recess and its polymer layers also reduced the transport of glucose to the wire electrode contacting sensing layer.

**[0012]** By limiting the glucose flux, the desired linear response range, spanning the clinically relevant glucose concentration range was obtained. The inventive biosensors are able to accurately measure, for example, approximately 2-30  $\mu\text{M}$  glucose and approximately 0.5-10  $\mu\text{M}$  lactate, in vivo. The sensor has no leachable components, and its four crosslinked polymer layers contain only about 5  $\mu\text{g}$  of immobilized material, and only a few nanograms of polymer-bound osmium. Preoxidation of the interferants in one of the four layers makes possible one-point in vivo calibration of the sensor.

#### BRIEF DESCRIPTION OF THE FIGURES

**[0013]** FIG. 1 is a schematic drawing of an electrode of the present invention.

**[0014]** FIG. 2 is a graphical representation of data generated comparing current density of glucose electrooxidation on electrodes made with PVI<sub>5</sub>-Os (open triangles) with those made with PVI<sub>3</sub>-Os (filled triangles).

**[0015]** FIG. 3 is a graphical representation of data generated comparing dependency of current generated on the depth of the recess.

**[0016]** FIG. 4 is a graphical representation of data generated comparing dependency of the ratio of the current generated and the charge required to electroreduce or oxidize the polymer redox centers in the sensing layer on the thickness of the sensing layer.

**[0017]** FIG. 5 is a graphical representation of data generated comparing variation of current generated by electrodes having sensing layers of differing thickness and diffusion limiting layers of different compositions and thickness. Solid circles: 7.5  $\mu\text{m}$  thick sensing layer of PVI<sub>5</sub>-Os (52%), rGOX (35%), PEGDGE (13%), coated with 4  $\mu\text{m}$  PAL/PAZ (1:1 ratio). Open circles: 5.0 sensing layer. Solid triangles: 12.5  $\mu\text{m}$  sensing layer and 7  $\mu\text{m}$  PAL/PAZ (1:2 ratio). Open triangles: 7.5  $\mu\text{m}$  sensing layer and 4.5  $\mu\text{m}$  PAL/PAZ (1:2 ratio).

**[0018]** FIG. 6 is a graphical representation of data generated comparing dependency of current generated on the presence of ascorbate, in the absence and presence of lactate and glucose. The concentrations of ascorbate (A), lactate (L) and glucose (G) are shown. Ascorbate is an electrooxidizable

interferant. Upon addition of lactate its electrooxidation current is suppressed while that of glucose is not suppressed.

**[0019]** FIG. 7 is a graphical representation of data showing current density and corresponding subcutaneous glucose concentration measured with the subcutaneously implanted electrodes of the present invention in a rat animal model. Large solid circles show blood glucose concentrations measured on withdrawn blood samples using a YSI analyzer.

**[0020]** FIG. 8 is a Clarke-type clinical grid analyzing the clinical relevance of the blood glucose measurements of FIG. 7.

**[0021]** FIG. 9 is a Clarke-type clinical grid of all possible correlations obtained when each of the 24 glucose analyses of FIG. 7 were used for single point calibration of either implanted electrode.

**[0022]** FIG. 10 is a Clarke-type clinical grid testing improvement of the single point calibration through redundant electrodes, the readings of which were within the standard deviation calculated for all differences between simultaneous readings by a pair of implanted electrodes.

#### DETAILED DESCRIPTION OF THE INVENTION

**[0023]** The present invention includes an insulated, non-corroding conducting metal (e.g., gold, platinum, palladium) or carbon wire-based small (e.g., 290  $\mu\text{m}$ ) O.D. subcutaneous glucose sensor, allowing one-point calibration in vivo. As shown in FIG. 1, its construction involves coating a small (e.g., 250  $\mu\text{m}$ ) diameter non-corroding metal or carbon wire 2 with an electrically insulating material 4, e.g., a polyimide, and, layering in a recess 6 formed by etching or removing a portion of the metal or carbon, the following active polymeric layers: an immobilized, "wired," glucose oxidase layer 8; an electrically insulating and glucose diffusion limiting layer 10 formed, for example, by crosslinking a polyallylamine (PAL) with a polyaziridine (PAZ); optionally, an interference eliminating layer 12, e.g., of crosslinked horseradish-peroxidase and lactate oxidase; and a biocompatible film 14 e.g., of poly(ethylene oxide) (PEO) derivatized to allow its photo-crosslinking. The outside diameter a of the wire 2 is preferably about 0.25 mm or less, and the outside diameter b of the insulated wire is preferably about 0.3 mm or less. The recess 6 in the insulated electrode extends from the tip 16 of the electrode which is open to the surrounding environment, to the top 18 of the wire 2 in the insulating sheath, generally for a length c of less than about 0.150 mm, and preferably about 0.125 mm.

**[0024]** The electrodes have no leachable components. The total amount of polymers and enzymes is preferably about 5  $\mu\text{g}$ . The glucose response through the physiologically relevant 2-20 mM concentration range is close to linear. The electrodes do not respond to ascorbate, urate or acetaminophenol for at least about 36 hours. Their 10-90% response time is about 90 seconds at 2 mM glucose and about 30 seconds at 20 mM glucose. Their sensitivity, after about 30 minutes equilibration, is stable for about 72 hours at 37° C. in 10 mM glucose, the current deviating from the average by less than  $\pm 0.5\%$ . The electrodes have substantially no signal output, e.g., current, charge, or potential, when the concentration of the analyte to be measured is zero.

**[0025]** Two electrodes implanted subcutaneously in a rat tracked blood glucose levels, and their absolute, uncorrected current output was proportional to the blood glucose concentration. Analysis of the correlation between the blood glucose levels in the tail vein and the current output of the sensors in

the subcutaneous regions of the thorax and between the scapulae of the same rat showed that even when the probed sites and organs differed in the extreme, one point in vivo calibration was valid. The analysis also showed the value of implanting redundant sensors. Had clinical decisions been made based on individual sensor readings, calibrated at one point, 94% would have been clinically correct. By using redundant sensors and accepting only those pairs of readings that were within one standard deviation, the percentage of the clinically correct decisions was increased to 99%.

**[0026]** It is understood that one of skill in the art may substitute various components of the biosensor described above with known materials to obtain an modified biosensor using the principles outlined herein. For example, the following substitutions are contemplated:

**[0027]** Base electrode: The base electrode of the inventive sensor may be formed of a non-corroding metal or carbon wire, for example vitreous carbon, graphite, platinum, palladium, or gold. Gold is preferred, and is used in the following illustrative examples of the invention.

**[0028]** Insulator: The conductive metal or carbon wire is coated with an electrically insulating material, which also forms a wall about the recess which houses the active polymeric components. The insulating material may be, for example, polyurethane, teflon (fluorinated polymers), polyethyleneterephthalate (PET, Dacron) or polyimide. The insulating material is preferably a biocompatible polymer containing less than about 5% water when in equilibrium with physiological body fluids, e.g., subcutaneous tissue.

**[0029]** Recess: In general, the recess at the tip of the electrode is approximately 20 to 150  $\mu\text{m}$  in length *c*, and preferably is approximately 50 to 125  $\mu\text{m}$ .

**[0030]** Etching method: The method for etching metal from the tip of the electrode described herein may utilize chloride, bromide or iodide in the bath in lieu of cyanide as described. Bromide is preferred, because it is less toxic and, like  $\text{Au}(\text{CN})_2^-$ ,  $\text{AuBr}_4^-$  is a water soluble anion. Thus, in aqueous HBR, the metal, e.g., gold, can be etched by applying a sufficiently oxidizing potential where gold is electrolytically dissolved:



**[0031]** Wired Enzyme Layer: In the sensing enzyme-containing layer, glucose oxidase may be substituted with other redox enzymes to measure other relevant clinical compounds. For example, lactate oxidase may be used for the in vivo detection of lactate, important in determining if an organ is receiving sufficient oxygen through the blood.

**[0032]** Useful redox polymers and methods for producing the sensing layer are described, for example, in U.S. Pat. Nos. 5,264,104; 5,356,786; 5,262,035, and 5,320,725. Additional redox polymers include, for example, poly(1-vinyl imidazole); poly(4-vinyl pyridine); or copolymers of 1-vinyl imidazole such as poly(acrylamide co-1-vinyl imidazole) where the imidazole or pyridine complexes with  $[\text{Os}(\text{bpy})_2\text{Cl}]^{+/2+}$ ;  $[\text{Os}(4,4'\text{-dimethyl bipyridine})_2\text{Cl}]^{+/2+}$ ;  $[\text{Os}(4,4'\text{-dimethyl phenanthroline})_2\text{Cl}]^{+/2+}$ ;  $[\text{Os}(4,4'\text{-dimethoxy phenanthroline})_2\text{Cl}]^{+/2+}$ ; and  $[\text{Os}(4,4'\text{-dimethoxy bipyridine})_2\text{Cl}]^{+/2+}$ ; to imidazole rings. The imidazole ring compounds are preferred because their complexes have more reducing redox potentials, i.e., closer to that of the SCE potential. At these more reducing potentials, the rate of electrooxidation of interferants and the current generated thereby.

**[0033]** Barrier Layer: The polymeric barrier layer is electrically insulating and limits diffusion of glucose through to

the sensing layer. It may be formed, for example, by crosslinking a polyallylamine (PAL) with a polyaziridine (PAZ). Alternatively, PAL may be replaced wholly or in part with a zwitterionic polymer obtained by quaternizing poly(vinylpyridine) with bromoacetate and dialyzing against 0.15M NaCl or by a polyanion such as a polysulfonic acid.

**[0034]** The barrier layer may contain a polyanionic polymer, in which the rate of permeation of anionic interferants such as ascorbate and urate is slowed. This layer may also contain a polycation that enhances the retention of the polyanion by electrostatic bonds and improves wetting by the biocompatible layer.

**[0035]** Interference Eliminating Layer: As described above, this layer is optional, in that it is not required when a redox polymer having a more reducing potential is used, such as  $\text{PVI}_{1.5}\text{-dmeOs}$  (Ohara et al., Analytical Chemistry, 1994, 64:2451-2457). At operating potentials of approximately  $-0.10$  to  $+0.25$  for the glucose biosensor, the rate of electrooxidation of interferants such as ascorbate, urate and acetaminophen is very slow relative to that of glucose through its physiological concentration range.

**[0036]** When a separate interferant eliminating layer is used, it preferably contains a peroxidase enzyme which may or may-not be preactivated. Such interferant eliminating layers are disclosed, for example, in U.S. Pat. No. 5,356,786, which discloses the structure and function of interferant eliminating biosensors. The glucose biosensor preferably contains lactate oxidase (LOX) in combination with peroxidase in the interferant eliminating layer. However, for biosensors used to detect lactate, glucose oxidase would be used with peroxidase. In a similar manner, the enzyme composition of the interferant eliminating layer may be altered for a specified function.

**[0037]** Biocompatible Layer: In general, the biocompatible layer is comprised of hydrogels, e.g., polymeric compositions which contain more than about 20% by weight of water when in equilibrium with a physiological environment such as living tissue or blood. An example is crosslinked poly(ethylene oxide), e.g., poly(ethylene oxide)/tetraacrylate. The polymeric compositions must be non-toxic and compatible with living Systems.

**[0038]** Method for making multi-layered recessed biosensors: Insulated non-corroding metal or carbon wires that have been etched as described above to contain a recess at the tip, are placed in a block that serves as an X-Y positioner. The wires vertically traverse the block and are held in place, e.g., by pressure. The blocks with the wires can be formed of elements, each element having multiple half-cylinder grooves running vertically. The wires are placed in these grooves and the elements are assembled into the block using screws. For example, the block may be formed of aluminum having equally spaced holes, (900 for a 30x30 array of wires), each hole to contain one wire. The block is positioned under a fixed micronozzle that ejects a fluid in to the recess of the insulated wire.

**[0039]** To reduce the requirement of precision in the positioning of the block and the micronozzle, the nozzle is electrically charged, with the wire having an opposite charge, or the wire being grounded or at least having a potential such that there is a potential difference between the nozzle and the wire. Because the nozzle is charged, the microdroplets it ejects are also charged with the same type of charge (positive or negative) as the nozzle. The higher the potential on the nozzle (e.g., versus ground potential), the higher the charge

on the ejected microdroplets. If the tip of the wire to be coated is at ground potential or has a charge of the opposite type, the charged microdroplets are guided into the recess to deposit on the electrode, even if the jet of microdroplets is not vertical, i.e., even if the micronozzle is not precisely aligned above the wire's tip.

**[0040]** Furthermore, the higher the electrical potential on the nozzle (relative to ground) the greater the charge on the ejected microdroplet. When the charge is high enough, the droplet breaks up into two or more smaller droplets because of electrostatic repulsion of charges on the droplet. Thus, the very small droplets all "drift" (drift meaning transport assisted by an electrical field) to the recessed electrode surface and are collected on it, even if they did not originate in a nozzle precisely aligned with the electrode.

**[0041]** This coating method is useful in making any small biosensor, not only those in recessed zones.

**[0042]** Clinical Use of the Recessed Biosensors:

**[0043]** The recessed biosensors of the present invention have sufficient sensitivity and stability to be used as very small, subcutaneous biosensors for the measurement of clinically relevant compounds such as glucose and lactate. The electrodes accurately measure glucose in the range of about 2-30  $\mu\text{M}$  and lactate in the range of about 0.5-10 mM. One function of the implanted biosensor is to sound an alarm when, for example, a patient's glucose concentration is too low or too high. When pairs of implanted electrodes are used, there are three situations in which an alarm is triggered: low glucose concentration, high glucose concentration; sensor malfunction as determined by a discrepancy between paired readings of the two sensors. A discrepancy sufficient to trigger the alarm may be, for example more than two or three times the standard deviation persisting for a defined period, e.g., not less than ten minutes. Such a system may be useful in sleeping patients, and also in emergency and intensive care hospital rooms, where vital functions are continuously monitored.

**[0044]** Another function of the inventive biosensors is to assist diabetics in maintaining their blood glucose levels near normal. Many diabetics now maintain higher than normal blood glucose levels because of danger of coma and death in severe hypoglycemia. However, maintaining blood glucose levels substantially, e.g., approximately 40% or more above normal leads to retinopathy and blindness as well as to kidney failure. Use of the subcutaneous biosensors to frequently, if not continuously, monitor glucose concentrations is desirable so that glucose concentrations can be maintained closer to an optimum level.

**[0045]** The subcutaneous biosensors can be used to measure the rate of rise and decline of glucose concentrations after a meal or the administration of glucose (e.g., a glucose tolerance test). The sensors are also useful in feedback loops for automatic or manually controlled maintenance of glucose concentrations within a defined range. For example, when used in conjunction with an insulin pump, a specified amount of insulin is delivered from the pump if the sensor glucose reading is above a set value.

**[0046]** In all of these applications, the ability to promptly confirm that the implanted sensor reading is accurate is essential. Prompt confirmation and rapid recalibration are possible only when one-point calibration is valid. Generally, even if a sensor's response is linear through the relevant concentration range, calibration requires at least two blood or fluid samples, withdrawn from the patient at times when the glucose con-

centration differs. It usually takes several hours for the glucose concentration to change sufficiently to validate proper functioning by two-point calibration. The ability to confirm and recalibrate using only one point is thus a highly desirable feature of the present invention.

**[0047]** Redundant sensors (e.g., at least two) are preferred in the clinical application of the subcutaneous biosensors. Such redundancy permits signaling of failure of any one sensor by recognition of an increase in the discrepancy between the readings of the sensors at one time point, e.g., more than two standard deviations apart. The redundant sensors may be implanted near each other or at remote sites.

**[0048]** It is preferred that the biosensors be implanted in subcutaneous tissue so as to make the sensor relatively unobtrusive, and at a site where they would not be easily dislodged, e.g., with turning or movement. It is also preferred, when readings are not corrected for temperature (which they generally are) that the sensors be implanted where they are likely to be at body temperature, e.g., near 37° C., and preferably covered by clothing. Convenient sites include the abdomen, inner thigh, arm.

**[0049]** Although we describe here continuous current measurement for assaying glucose, the electrical measurement by which the glucose concentration is monitored can be continuous or pulsed. It can be a current measurement, a potential measurement or a measurement of charge. It can be a steady state measurement, where a current or potential that does not substantially change during the measurement is monitored, or it can be a dynamic measurement, e.g., one in which the rate of current or potential change in a given time period is monitored. These measurements require at least one electrode in addition to the sensing electrode. This second electrode can be placed on the skin or can be implanted, e.g., subcutaneously. When a current is measured it is useful to have a potentiostat in the circuit connecting the implanted sensing electrode and the second electrode, that can be a reference electrode, such as an Ag/AgCl electrode. When a current is measured the reference electrode may serve also as the counter electrode. The counter electrode can also be a separate, third electrode, such as a platinum, carbon, palladium or gold electrode.

**[0050]** In addition to implanting the sending electrode in the body, fluid from the body, particularly fluid from the subcutaneous region, can be routed to an external sensor. It is preferred in this case to implant in the subcutaneous region a microfiltration giver and pull fluid to an evacuated container, the fluid traversing a cell containing the sensing electrode. Preferably this cell also contains a second electrode, e.g., a reference electrode which may serve also as a counter electrode. Alternatively, the reference and counter electrodes may be separate electrodes. In coulometric measurements only two electrodes, the sensing electrode and the counter electrode are required. The flow of body fluid may be pulsed or continuous. Other than an implanted microfiltration fiber, also a microdialysis fiber may be used, preferably in conjunction with a pump.

**[0051]** Increased Stability of the Biosensors:

**[0052]** To increase the stability and useful life of the inventive biosensors, it is advantageous to use intrinsically more stable enzymes and redox polymers. However, even if the enzyme and redox polymer degrade in the glucose electrooxidation process by which the signal (current) is generated, it is

possible to greatly extend the useful life of the implanted electrodes and reduce the frequency of their required recalibration after implantation.

**[0053]** A simple measure by which the life of the implanted electrodes can be extended and the frequency of their required recalibration reduced involves turning the electrodes "on" by applying a bias, i.e., a potential, only during the period of measurement, then turning the biasing potential off or reducing it, so that a lesser current will flow. It is generally sufficient to perform only one measurement every five or even ten minutes, or longer, because glucose concentrations do not change abruptly.

**[0054]** Another measure is to lower the glucose flux to the sensing layer much as possible, consistent with maintaining adequate sensitivity and detectivity. Reduction of the glucose flux to the sensing layer reduces the current. Therefore, even though this stabilizes the electrodes, i.e., slows the loss in sensitivity, the flux dependent current must not be excessively reduced. Usually a current of 3-5 nA at 2 mM glucose concentration is adequate. When the glucose flux is lowered by using one or more glucose-flux reducing polymer slayers, such as the PAL/PAZ layer, the lifetime of the sensor is increased.

## EXAMPLES

### Example 1

#### Electrode Preparation

**[0055]** Electrodes were made of a polyamide-insulated 250  $\mu\text{m}$  diameter gold wire, having an outer diameter (O.D.) of 290  $\mu\text{m}$  (California Fine Wire Co., Grover City, Calif.). Heat shrinkable tubing (RNF 100 {fraction  $(\frac{3}{64})$ } "BK and {fraction  $(\frac{1}{16})$ } "BK, Thermofit.RTM., Raychem, Menlo Park, Calif.) and a two component silver epoxy (Epo-tek H<sub>2</sub>O<sub>2</sub>; Epoxy Tech, Inc., Billerica, Mass.) were used for electrode preparation.

**[0056]** The glucose sensing layer was made by crosslinking a genetically engineered glucose oxidase (rGOX) (35% purity, Chiron Corp., Emeryville, Calif.) with a polymer derived of poly(vinylimidazole) (PVI), made by complexing part of the imidazoles to [Os(bpy)<sub>2</sub>Cl]<sup>+2+</sup>. The resulting redox polymer, termed PVI-Os, was synthesized according to a previously published protocol. (Ohara et al., 1993, Anal. Chem., 65:24). Poly(ethylene glycol) diglycidyl ether 400 (PEDGE; Polysciences, Warrington, Pa.) was used as the crosslinker.

**[0057]** The barrier layer between the sensing and interference-eliminating layers was made of polyallylamine (PAL; Polysciences) crosslinked with a polyfunctional aziridine (PAZ) (XAMA-7; Virginia Chemicals, Portsmouth, Va.).

**[0058]** The interference-eliminating layer was prepared by co-immobilizing horseradish peroxidase (HRP) type VI (Cat. No. P-8375, 310 U/mg, denoted herein as HRP-VI, Sigma, St. Louis, Mo.) and HRP for immunological assay (No. 814407, min 1000 U/mg, denoted HRP-BM, Boehringer-Mannheim, Indianapolis, Ind.) with lactate oxidase from *Pediococcus* sp. (Cat. No. 1361, 40 U/mg denoted LOX, Genzyme, Cambridge, Mass.) and a recombinant microbial source (Cat. No. 1381 denoted rLOX, Genzyme). Co-immobilization was performed using sodium periodate (Cat. No. S-1147, Sigma) according to the methods described in Maidan and Heller, 1992, Anal. Chem. 64:2889-2896.

**[0059]** The biocompatible layer was made of 10% aqueous poly(ethylene oxide) tetraacrylate (PEO-TA). To form the

photocrosslinkable polymer, PEO was acrylated by reaction with acryloyl chloride. The 18,500 g/mol PEO (Polysciences) is a tetrahydroxylated compound by virtue of two hydroxyl groups on a bisphenol A bisepoxide that linked two alpha-, .omega.-hydroxy-terminated 9,000 g/mol PEO units. Acryloyl chloride (Aldrich, Milwaukee, Wis.) in a 2 to 5 molar excess was used to acrylate the polymer (10% w/v PEO in benzene). Triethylamine (Mallinkrodt, Paris, Ky.) was used as a proton acceptor equimolar with the acryloyl chloride.

**[0060]** Other chemicals used were bovine serum albumin (BSA) fraction V (Cat. No. A-2153), BSA, ascorbic acid, uric acid, 4-acetaminophenol, L(+)=lactic acid, and hydrogen peroxide 30%, all from Sigma. All chemicals were used as received. Solutions (if not otherwise specified) were made with distilled, deionized water. Glucose monitoring was performed in buffer, in bovine serum (Sigma, Cat. No. S-6648) containing antibiotic-antimycotic solution (Sigma, Cat. No. A-8909) at 37° C. and in rats.

**[0061]** Instrumentation

**[0062]** In making the recessed gold electrodes, a potentiostat/galvanostat (PAR Model 173, Princeton Applied Research, Princeton, N.J.) operated in a galvanostatic mode, and a sonicator (Fisher scientific, Pittsburgh, Pa.) were used. Cyclic voltammograms were recorded with a potentiostat (PAR Model 273A) and a conventional electrochemical cell having a Pt wire counter and a SCE reference electrode and were evaluated with PAR 270 software. Glucose signals were monitored with a bipotentiostat (Biometra EP 30) and a two channel strip-chart recorder. The recessed electrodes were coated under a microscope (Bausch & Lomb) using a micromanipulator (Narishige, Seacliff, N.Y.). The micropipettes were pulled with a micropipette puller (Narishige). Temperature was controlled with an isothermal circulator (Fisher Scientific).

**[0063]** Electrode Preparation:

**[0064]** Five cm lengths of polyamide insulated gold wire were cut with a sharp razor blade. Electrical contact was made at one end with silver epoxy to an insulated stainless steel wire and the junction was covered with insulating heat shrinkable tubing. The recess forming electrochemical etching process was carried out in 10 ml of 3M potassium cyanide, with the gold wire as the working electrode and a platinum or gold wire as the counter electrode. The wires were placed in contact with the bottom of the beaker, all electrodes being equidistant from the counter electrode. The beaker was sonicated during the etching procedure. The ends of the gold wires were bent upwards, so that agitation by the sonicator caused the oxygen bubbles formed during the etching process to rise and escape. The electrodes were then thoroughly washed and immersed in water for 30 minutes.

**[0065]** A recess 6, i.e., channel, in a polyamide insulated gold wire 2 is formed by electrochemical etching of the gold under galvanostatic control. By controlling the charge, the total amount of gold electrooxidized and dissolved as Au(CN)<sub>2</sub> is defined.

**[0066]** When the conditions were set so that the CN— transport into the channel and the Au(CN)<sub>2</sub>— transport out of it are not rate limiting, (e.g., sonicated bath and high concentration of potassium cyanide, at least approximately 0.2M, and preferably 3M), a flat gold wire surface is produced at the bottom of channels with aspect ratios of 0.5 to 2.0. Thus, when the CN— concentration is high enough and the wires are ultrasonically vibrated, the tips of gold wires are flat. Passage of 1.5 coulombs per electrode at 8 mA current pro-



duced approximately 125  $\mu\text{m}$  deep cavities or channels. At theoretical efficiency for one-electron oxidation, 3.08 mg of gold would have been etched. The amount of gold actually etched was only 0.076 mg, showing significant CN— or water oxidation.

**[0067]** Nevertheless, the process is reproducible, accurate and fast with 20 electrodes being processed in each batch in less than five minutes. The recess-forming procedure was highly reproducible, with a deviation of  $\pm 10$   $\mu\text{m}$  found (using an objective micrometer) for a batch of 30 recessed electrodes. Before coating, the electrodes were examined under a microscope for flatness of the gold surface and correct depth.

**[0068]** FIG. 1 shows a schematic side view in cross-section of an electrode of the present invention, showing the gold wire 2, insulating coating 4, and recess or channel 6. The recessed gold surfaces were coated by filling of the cavities or channels 6 with aqueous solutions containing the crosslinkable components of the different layers, and their crosslinkers. The solutions were introduced under a microscope with a micropipette (connected to a microsyringe by polyethylene tubing and shrink tubing), using a micromanipulator. After application of each of the individual layers, the electrodes were cured overnight at room temperature, in air.

**[0069]** Electrode Structure:

**[0070]** The electrodes were prepared by sequentially depositing four layers within the recess or channel 6. The layers were: the sensing layer 8, the insulating layer 10, the interference-eliminating layer 12 and the biocompatible layer 14. The sensing layer, containing “wired” redox enzyme is positioned adjacent to and in contact with the gold wire 2. The insulating layer 10 is positioned between the sensing layer 8 and the peroxidase-based interferant-eliminating layer 12. The biocompatible layer 14 fills the remaining space in the recess 6 and is in contact with the environment outside the electrode. The thin polymer layers are well protected by containment within the polyamide sleeve 4.

**[0071]** The sensing layer 8 was made by “wiring” rGOX to the gold electrode through a redox hydrogel to which the enzyme was covalently bound. The electrodes were prepared as follows: 10 mg/ml solutions were made from

**[0072]** 1. the PVI-Os redox polymer in water,

**[0073]** 2. the crosslinker, PEGDGE, in water, and

**[0074]** 3. the enzyme, rGOX, in a 10 mM HEPES solution adjusted to pH 8.15.

**[0075]** A redox hydrogel was formed by mixing the three solutions so that the final composition (by weight) was 52% redox polymer, 35% enzyme and 13% crosslinker.

**[0076]** The insulating layer 10 prevented electrical contact between the redox hydrogel and the interference eliminating enzymes (HRP and LOX). PAL:PAZ was used as the insulating material. The film was deposited from a solution obtained by mixing in volume ratio of {fraction (1/1)},  $\frac{1}{2}$  or  $\frac{1}{3}$ , a PAL solution (4.5 mg in 100 mM HEPES buffer at pH 7.0) and a freshly prepared PAZ solution (30 mg/ml). The PAZ solution was used within 15 minutes of preparation.

**[0077]** The interference-eliminating layer 12 was prepared according to a previously published protocol, Maidan and Heller, 1992, Anal. Chem., 64:2889-2896. 50  $\mu\text{l}$  of a 12 mg/ml freshly prepared sodium periodate solution was added to 100  $\mu\text{l}$  of a solution containing 20 mg/ml HRP (HRP-VI or HRP-BM) and 100 mg/ml LOX (LOX or rLOX) in 0.1 M sodium bicarbonate and the mixture was incubated in the dark for two hours. Alternatively, the oxidation of HRP could be carried out prior to adding LOX and crosslinking.

**[0078]** The biocompatible layer 14 films were photocrosslinked by exposure to UV light (UVP, Inc., San Gabriel, Calif.; Blak-Ray; spectral peak at 360 nm UV irradiance at the sample 200 mW/cm<sup>2</sup>) for one minute. The initiator used was 2,2-dimethoxy-2-phenylacetophenone (Aldrich). A solution of 300 mg/ml of the initiator in 1-vinyl-2-pyrrolidone (Aldrich) was added to the prepolymer mixtures. Approximately 30  $\mu\text{l}$  of the initiator solution was added per ml of 10% w/w aqueous solution of the tetraacrylated PEO. The prepolymers were crosslinked in situ inside the recess of the electrode. The films were prepared by filling the recess with the prepolymer solution twice and exposing the electrode to the UV light source after each time the cavity was filled.

**[0079]** In vitro Testing of Electrodes:

**[0080]** In vitro experiments were carried out in batch fashion at 25° and 37° C., using a conventional three electrode electrochemical cell with the enzyme-modified gold wire as the working electrode, a platinum wire as the counter electrode and a saturated calomel reference electrode (SCE). The electrolyte was a 20 mM phosphate buffered-saline solution containing 0.15 M NaCl at pH 7.15. Experiments in serum were performed at 37° C., adding 100  $\mu\text{L}$  antibiotic-antimycotic solution to 10 ml serum. Phosphate buffered-saline and serum were agitated during the experiments. The working potential was +0.3 V versus SCE for experiments with the PVI-Os polymers.

**[0081]** Structure and Performance: The depth *c* of the channel 6 and the thickness of the polymer layers in it controls the mass transport, i.e., flux of glucose, to the sensing layer. By controlling these parameters, the apparent Michaelis constant ( $K_m$ ) is adjusted to about 20-30 mM glucose. The polyimide wall 4 of the channel 6 also protects the four polymer and polymer/enzyme layers 8, 10, 12, 14 against mechanical damage and reduces the hazard of their loss in the body. Because the glucose electrooxidation current is limited by glucose mass transport through the recess 6 and its polymer films 8, 10, 12, 14, rather than by mass transport to the tissue-exposed tip 16, the current is practically insensitive to motion. Evidently, the electrooxidation rate of glucose in the recessed sensing layer 8 is slower than the rate of glucose diffusion to the channel's outer fluid contacting interface.

**[0082]** PVI<sub>5</sub>-Os is preferred as the “wire” of the sensing layer when an interference eliminating layer of HRP and LOX is used, but not in the absence of this layer, i.e., when redox polymers with more reducing redox potential are preferred. The subscript (5) is used to indicate that, on the average, every fifth vinylimidazole mer carries an electron-relaying osmium center. Use of electrodes formed with PVI<sub>5</sub>-Os and PVI<sub>3</sub>-Os (every third 1-vinylimidazole mer carrying an osmium center) are compared in FIG. 2, and show higher current density of glucose electrooxidation on electrodes made with PVI<sub>5</sub>-Os (open triangle) than on those made with PVI<sub>3</sub>-Os (filled triangles).

**[0083]** Depth of the recess and the sensing layer: Channels of 125, 250, and 500  $\mu\text{m}$  depth, were investigated to assess the dependence of the current on the depth of the recess (FIG. 3), with the total amount of PVI<sub>5</sub>-Os and rGOX being kept constant. Much of the loss in current in the deeper cavities resulted not from reduced glucose mass transport, but from adsorptive retention of part of the enzyme and polymer on the polyamide wall when microdrops of the component solutions were introduced into the recess in the process of making the electrodes. Through repeated rinsing with water, some of the

adsorbed polymer and enzyme on the walls were washed onto the electrode surface, increasing the current. The highest currents were seen after five washings. When the thickness of the sensing layer was increased through increasing the number of coatings (FIG. 4) the ratio of current to charge required to electroreduce or electrooxidize the redox polymer in the sensing layer reached a maximum, then dropped. For the preferred 125  $\mu\text{m}$  recess, 10 coatings, producing an approximately 13  $\text{Am}$  thick wired-rGOX sensing layer, yielded sensors that had the desired characteristics for *in vivo* use.

**[0084]** The insulating layer: This layer electrically insulates the redox enzymes of the interference eliminating layer (HRP and LOX) from the "wired" rGOX layer and limits the glucose flux to the sensing layer, thereby extending the useful life of the electrode. PAL crosslinked with PAZ, forming a polycationic network at pH 7.09 is preferred. The best results, i.e., best stability of current outputs, were obtained using 1:2 PAL:PAZ (FIG. 5), with three coatings applied to form an approximately 7  $\mu\text{m}$  thick crosslinked film.

**[0085]** The interference eliminating layer: Interferants, particularly ascorbate, urate, and acetaminophenol, are oxidized in the third layer, containing LOX and HRP. In this layer, lactate, the typical concentration of which in blood is 1 mM, reacts with  $\text{O}_2$  to form  $\text{H}_2\text{O}_2$  and pyruvate.  $\text{H}_2\text{O}_2$ , in the presence of HRP, oxidizes ascorbate, urate, and acetaminophenol, being reduced to water. The preferred coimmobilization process involved two separate steps: periodate oxidation of oligosaccharide functions of HRP to aldehydes, followed by mixing with LOX and formation of multiple Schiff bases between HRP-aldehydes and LOX amines (e.g. lysines) and between HRP aldehydes and amines. The thickness of the interference eliminating layer is approximately 85  $\mu\text{m}$  and is made by applying successive coatings, e.g., about six coatings. FIG. 6 shows that electrooxidizable interferants were eliminated in the presence of lactate at physiological levels. LOX slowly lost its activity in the crosslinked HRP-LOX layer. This led to degradation of the ability of the layer to eliminate interferants. After 36 hours of operation at 37° C., a measurable current increment was noted when enough ascorbate was added to produce a 0.1 mM concentration.

**[0086]** The biocompatible layer: A preferred biocompatible layer consists, for example, of photocrosslinked tetraacrylated 18,500 Da poly(ethylene oxide) (Pathak et al., 1993, J. Am. Chem. Soc., 114:8311-8312). The thickness of this layer, made by sequential photo-crosslinking of two coatings, is about 20  $\mu\text{m}$ . One minute UV exposure required for the photocrosslinking process reduced the sensitivity by 16+/-2%.

#### Example 2

**[0087]** *In vivo* Use of Sensor

**[0088]** The objective of this experiment was to establish the validity of a one-point *in vivo* calibration. Two sensors were simultaneously implanted subcutaneously in a rat, one on the thorax, the second between the scapulae. To make the difference between the blood sampled and the subcutaneous fluid proved with the sensors as extreme as possible, i.e., to probe whether the one-point calibration holds even if the organs sampled are different and the sampling sites are remote, blood was withdrawn from the tail vein. Blood glucose levels were periodically measured in withdrawn samples, while the absolute uncorrected sensor current output was continuously monitored.

**[0089]** *In vivo* experiments (6-10 hours) were carried out in 300 g male Sprague-Dawley rats. The rats were fasted overnight and prior to the experiment were anaesthetized with an intraperitoneal (i.p.) injection of sodium pentobarbital (65 mg/kg rat wt). An i.p. injection of atropine sulfate (166 mg/kg rat wt) was then administered to suppress respiratory depression. Once the rat was anaesthetized, a portion of the rat's abdomen was shaved, coated with a conductive gel, and an Ag/AgCl surface skin reference electrode was attached. This electrode served also as the counter electrode. Sensors were then implanted subcutaneously using a 22 gauge Per-Q-Cath Introducer (Gesco International, San Antonio, Tex.) on the rat's thorax, or subcutaneously in the intrascapular area through a small surgical incision. The sensors were taped to the skin to avoid sensor movement. The sensors, along with the reference electrode, were connected to an in-house built bipotentiostat. The operating potential of the sensors was 0.3 V vs. Ag/AgCl, with the Ag/AgCl electrode serving as both the reference counter electrode. Sensor readings were collected using a data logger (Rustrak Ranger, East Greenwich, R.I.) and at the end of the experiment were transferred to a computer. During the experiment, the rat's body temperature was maintained at 37° C. by a homeostatic blanket. The sensors were allowed to reach a basal signal level for at least one hour before blood sampling was started. Blood samples were obtained from the tail vein and all blood samples were analyzed using a glucose analyzer (YSI, Inc., Yellow Springs, Ohio; Model 23A).

**[0090]** Approximately thirty minutes after the start of blood sampling, an i.p. glucose infusion was started using a syringe pump (Harvard Apparatus, South Natick, Mass.) at a rate of 120 mg glucose/min kg rat wt. The glucose infusion was maintained for approximately one hour.

**[0091]** As seen in FIG. 7, at 410 min the current dropped precipitously. Such a drop was observed in other measurements with subcutaneously implanted electrodes between 400 and 600 min, but was never observed in electrodes operated in buffer at 37° C. When the failed electrodes were withdrawn and retested in buffer, most of their original sensitivity was found to be intact. The cause for this apparent deactivation was failure of the counter/reference Ag/AgCl electrode on the rat's skin to make good electrolytic contact, and was not due to any failure of the implanted sensor. Using an arbitrarily chosen point to calculate a calibration curve for each electrode, i.e., one blood glucose level determination and one current measurement to establish the scales, all the data from FIG. 7 were plotted in a Clarke-type, (Clarke et al., 1987, Diabetes Care, 5:622-627) clinical grid (FIG. 8), without further correction. In this analysis, points falling in region A of the grid are considered clinically accurate, while those in region B are considered clinically correct. Points falling in region C are not correct, but would not lead to improper treatment. Points in regions D and E are incorrect and if treatment would rely on these, it would be improper.

**[0092]** All of the points, from both electrodes, were in regions A and B, with 43 of the 48 points being in region A. The three points in region B near 100 mg/dl glucose, for the electrode implanted between the scapulae, were the last three points of the experiment, at about 410 min. Notwithstanding the failure mode at 400-600 min because of poor electrolytic contact of the counter/reference electrode with the skin and failure after 36 hours by deactivation of the lactate oxidase, resulting in loss of interference elimination, one-point calibration is shown here to be practical. After such calibration,

the readings of the subcutaneous sensors provide, without any correction, clinically useful estimates of blood glucose levels.

**[0093]** FIG. 9 shows the distribution of all possible correlations obtained when each of the 24 glucose analyses was used for single point calibration of either implanted electrode. There are  $2 \times 24 \times 24 = 1152$  points in the distribution. Of these, 78% are in region A, 15% are in region B, 1% in region C, 6% are in region D, and no points are in region E.

**[0094]** In FIG. 10, we tested for the improvement of the single point calibration through using redundant electrodes. First, the readings of electrode A were normalized with respect to those of electrode B by multiplying each reading by the average output of electrode B divided by the average output of electrode A. Next the standard deviation was calculated for the differences between the 24 sets of readings of implanted electrode B and corrected readings of implanted electrode A. Then, all those sets of readings that differed by more than the standard deviation were rejected. The number of sets was reduced thereby from 24 to 11; 82% of the points were in region A, 17% in region B, 1% in region D, and no points in regions C and E. The distribution demonstrates that the sensors can be calibrated through a single independent measurement of the glucose concentration in a withdrawn blood sample. They also demonstrate the improvement in clinical accuracy resulting from the use of redundant subcutaneous sensors. The selection of those data points that differed by less than the standard deviation for the entire set led to a sixfold reduction in the probability of clinically erring in a decision based on readings of the implanted sensors.

**[0095]** Stability and Other Characteristics:

**[0096]** In order to improve the stability, more thermostable recombinant GOX, (RGOX; Heller, 1992, J. Phys. Chem., 96:3579-3587) rather than GOX is used in the sensor and glucose transport is reduced to make the sensor current diffusion, not enzyme turnover, limited. The glucose flux is attenuated by the three outer layers and the sensing layer itself. Because the sensing layer contains a large excess of glucose oxidase, its activity greatly exceeds that needed for electrooxidizing the attenuated glucose flux, and the sensor's stability is improved.

**[0097]** The stability can be tested by methods known, for example, tested in the presence of 0.1 mM ascorbate in 10 mM glucose at 37° C. The current output of a typical optimized electrode was about 35 nA and the apparent  $K_m$ , derived from an Eadie-Hofstee plot, was about 20 mM (Table 1). The 10-90% response time was approximately one minute.

**[0098]** As expected, and as can be seen in FIG. 5, with thinner films the glucose mass transport was increased, i.e., the current was higher, while for thicker films the stability was improved. Because of the high sensitivity of thin sensing film (approximately 1  $\mu\text{m}$ ) electrodes (less than  $10^{-2} \text{ A cm}^{-2} \text{ M}^{-1}$ ), an order of magnitude decrease in sensitivity could be traded for stability, while the currents remained high enough to be easily measured.

**[0099]** As seen in FIG. 5, the sensitivity of the stabilized sensors does not change by more than +5% for 72 hours of operation at 37° C. After a small initial decrease in sensitivity, it increased to a maximum after 40 hours and the final 72 hour sensitivity was almost identical with the initial.

**[0100]** The characteristics of the electrodes of the present invention are summarized in Table 1. Each entry represents an average value for five tested electrodes. Baseline currents are typically less than 0.5 nA and the noise less than 10 pA. The

currents observed throughout the physiological glucose concentration range (2-20 mM) exceed the noise equivalent current by at least a factor of 100. The apparent  $K_m$  is 20 mM, and the 10% to 90% response time is, for aged electrodes, about 90 seconds at the lowest physiologically relevant glucose concentration (2 mM) and 20 seconds at the highest (20 mM).

**[0101]** The baseline of nil at 0 mM glucose is stable for 36 hours in the presence of 0.1 mM ascorbate. The stability observed and the existence of a valid zero-point in the presence of interferants suggest that the sensor can be used in vivo for 72 hours and tested/recalibrated in vivo through a single point calibration, i.e., by withdrawing only a single sample of blood for independent analysis.

TABLE 1

SENSOR CHARACTERISTICS					
i (nA)	j ( $\mu\text{A}/\text{cm}^2$ )	$K_m^{\text{app}}$ (mM)		$t_r$ (s)	Current Variance (%)
		EH	LB		
33.9	69.1	18.5	33.4	30-90	5.0

where:

i is the current measured at 37° C. and at 10 mM glucose concentration  
j is the current density measured at 37° C. at 10 mM glucose concentration  
 $K_m^{\text{app}}$  is the apparent Michaelis-Menten coefficient determined from an electrochemical Eadie-Hofstee (EH) or Lineweaver-Burk (LB) plot  
 $t_r$  is the 10-90% risetime, 90s for 2 mM and 30 s for 20 mM glucose concentration.

Current Variance is the maximum deviation from the mean value, measured during the 72 hour test, conducted in 10 mM glucose in the presence of interferants. The current was continuously monitored at 37° C.

**[0102]** The foregoing examples are designed to illustrate certain aspects of the present invention. The examples are not intended to be comprehensive of all features and all embodiments of the present invention, and should not be construed as limiting the claims presented herein.

1. An electrochemical biosensor, comprising:  
a substrate having a first surface and a second surface; and  
at least one electrode formed on at least one of the surfaces of the substrate with a laser;  
wherein the biosensor includes an end for connecting with a device.

2-20. (canceled)

21. A method for fabricating an analyte sensor configured for insertion into a host's soft tissue, the method comprising: forming a biointerface having a plurality of passageways and a solid portion on at least a sensing portion of a sensor, wherein the sensor is configured to measure an analyte in the host, and wherein the sensor has an architecture with at least one dimension less than about 1 mm.

22. The method of claim 21, wherein the step of forming a biointerface comprises a method selected from the group consisting of electrospinning, writing, lyophilizing, wrapping, weaving, and molding.

23. The method of claim 21, wherein the step of forming a biointerface comprises electrospinning the biointerface onto the sensor, writing the biointerface onto the sensor, lyophilizing the biointerface onto the sensor, wrapping the biointerface onto the sensor, weaving the biointerface onto the sensor, and molding the biointerface onto the sensor.

24. The method of claim 21, wherein the step of forming a biointerface comprises forming the biointerface directly on the sensor.

25. The method of claim 21, wherein the step of forming a biointerface comprises pre-forming the biointerface and then applying the preformed biointerface to the sensor.

26. The method of claim 21, wherein the step of forming a biointerface comprises pre-forming the biointerface and inserting the sensor into the preformed biointerface.

26. The method of claim 21, wherein the step of forming a biointerface comprises: forming a selectively removable porogen on the sensor, wherein the porogen comprises particles formed onto the sensor and solidified to form a solidified mass of continuously interconnected particles; filling the porogen with a material; substantially solidifying the material; and removing the mass of continuously interconnected particles from contact with the sensor and solidified material to thereby form a solid portion that defines a plurality of passageways of the biointerface.

27. The method of claim 21, wherein the biointerface comprises a material selected from the group consisting of silicone, polytetrafluoroethylene, expanded polytetrafluoroethylene, polyethylene-co-tetrafluoroethylene, polyolefin, polyester, polycarbonate, biostable polytetrafluoroethylene, polyurethane homopolymer, polyurethane copolymer, polyurethane terpolymer, polypropylene, polyvinylchloride, polyvinylidene fluoride, polyvinyl alcohol, polybutylene terephthalate, polymethylmethacrylate, polyether ether ketone, polyamide, polyurethane, cellulosic polymer, poly(ethylene oxide), poly(propylene oxide), poly(propylene oxide) copolymer, polysulfone, polysulfone, block copolymers thereof, di-block copolymers thereof, tri-block copolymers thereof, alternating copolymers thereof, random copolymers thereof, graft copolymers thereof, mixtures thereof, and blends thereof.

28. The method of claim 21, wherein the step of forming a biointerface comprises forming an amorphous biointerface.

29. The method of claim 21, wherein the biointerface comprises pores of at least about 20 microns.

30. The method of claim 21, wherein the step of forming a biointerface comprises forming a fibrous biointerface.

31. The method of claim 31, wherein the biointerface comprises fibers less than about 6 microns in all but the longest dimension.

33. The method of claim 21, further comprising a step of incorporating a bioactive agent into the biointerface.

34. The method of claim 33, wherein the bioactive agent is selected from the group consisting of an anti-barrier cell agent, an anti-inflammatory agent, an anti-infective agent, a necrosing agent, an anesthetic, an inflammatory agent, a growth factor, an angiogenic factor, an adjuvant, an immunosuppressive agent, an antiplatelet agent, an anticoagulant, an ACE inhibitor, a cytotoxic agent, a vascularization compound, and an anti-sense molecule.

35. The method of claim 21, wherein the step of forming a biointerface comprises writing a biointerface onto the sensor using a computer-aided machine.

36. A method for fabricating an analyte sensor configured to be wholly implanted in a host's soft tissue, the method comprising: providing a sensor configured to measure an analyte in the host, wherein the sensor has an architecture with at least one dimension less than about 1 mm; and coating a biointerface onto the sensor, the biointerface comprising a plurality of cavities and a solid portion.

37. The method of claim 36, wherein the cavities are interconnected.

38. The method of claim 36, wherein the coating step comprises a method selected from the group consisting of electrospinning, writing, lyophilizing, wrapping, weaving, and molding.

39. The method of claim 36, further comprising a step of curing the biointerface.

40. The method of claim 36, wherein the coating step comprises: forming a selectively removable porogen onto the sensor, wherein the porogen comprises particles formed onto the sensor and solidified to form a solidified mass of continuously interconnected particles; filling the porogen with a material; substantially solidifying the material; and removing the mass of continuously interconnected particles from contact with the sensor and solidified material to thereby form a solid portion that defines a plurality of passageways of the biointerface.

41. The method of claim 36, wherein the biointerface comprises a material selected from the group consisting of silicone, polytetrafluoroethylene, expanded polytetrafluoroethylene, polyethylene-co-tetrafluoroethylene, polyolefin, polyester, polycarbonate, biostable polytetrafluoroethylene, polyurethane homopolymer, polyurethane copolymer, polyurethane terpolymer, polypropylene, polyvinylchloride, polyvinylidene fluoride, polyvinyl alcohol, polybutylene terephthalate, polymethylmethacrylate, polyether ether ketone, polyamide, polyurethane, cellulosic polymer, poly(ethylene oxide), poly(propylene oxide), poly(propylene oxide) copolymer, polysulfone, polysulfone, block copolymers thereof, di-block copolymers thereof, tri-block copolymers thereof, alternating copolymers thereof, random copolymers thereof, graft copolymers thereof, mixtures thereof, and blends thereof.

42. The method of claim 36, wherein the biointerface is an amorphous biointerface.

43. The method of claim 42, wherein the amorphous biointerface is molded onto the sensor.

44. The method of claim 36, wherein the coating step comprises forming a fibrous biointerface.

45. The method of claim 44, wherein the biointerface comprises fibers less than about 6 microns in all but the longest dimension.

46. The method of claim 36, further comprising a step of incorporating a bioactive agent into the biointerface.

47. The method of claim 46, wherein the bioactive agent is selected from the group consisting of an anti-barrier cell agent, an anti-inflammatory agent, an anti-infective agent, a necrosing agent, an anesthetic, an inflammatory agent, a growth factor, an angiogenic factor, an adjuvant, a wound factor, an immunosuppressive agent, an antiplatelet agent, an anticoagulant, an ACE inhibitor, a cytotoxic agent, a vascularization compound, and an anti-sense molecule.

48. The method of claim 36, wherein the coating step comprises writing a biointerface onto the sensor using a computer-aided machine.

49. The method of claim 36, further comprising a step of curing the biointerface.

50. A method for making an analyte sensor configured for insertion into a host's soft tissue, the method comprising: providing a sensor configured to measure an analyte in a host, wherein the sensor has an architecture with at least one dimension less than about 1 mm; and directly writing a porous biointerface, wherein the porous biointerface is written based on a predefined pattern stored in a computer system.

**51.** The method of claim **50**, further comprising a step of curing the biointerface during direct writing step or after the direct writing step.

**52.** The method of claim **50**, wherein the porous biointerface is directly written onto the sensor.

**53.** The method of claim **50**, wherein the porous biointerface is directly written onto a substrate and then applied to the sensor.

\* \* \* \* \*