

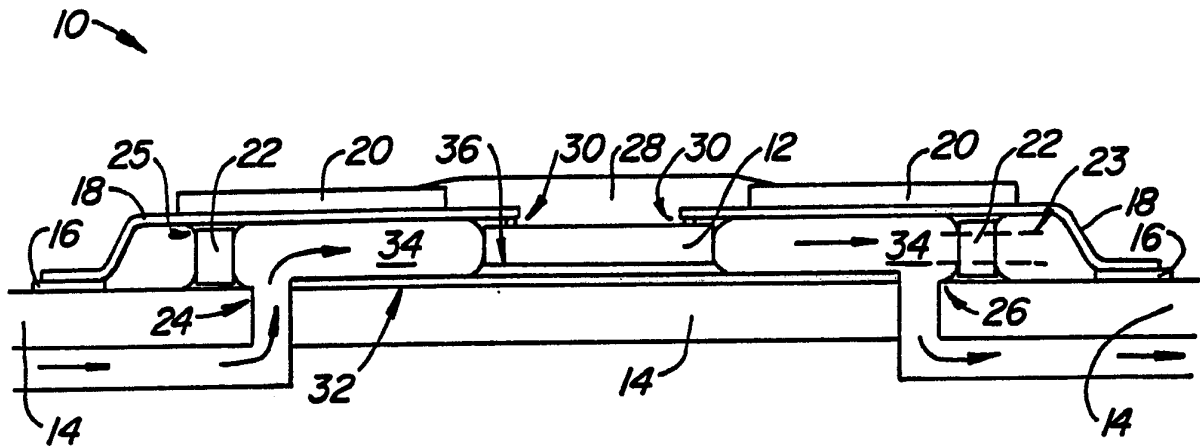

INTERNATIONAL APPLICATION PUBLISHED UNDER THE PATENT COOPERATION TREATY (PCT)

<p>(51) International Patent Classification⁵ : H01L 23/48, 39/02, 25/04 H02B 1/00, H05K 7/20</p>	A1	<p>(11) International Publication Number: WO 92/22089 (43) International Publication Date: 10 December 1992 (10.12.92)</p>
<p>(21) International Application Number: PCT/US92/03486 (22) International Filing Date: 28 April 1992 (28.04.92) (30) Priority data: 710,740 3 June 1991 (03.06.91) US (71) Applicant: VLSI TECHNOLOGY, INC. [US/US]; 1109 McKay Drive, San Jose, CA 95131 (US). (72) Inventor: LONG, Jon, M. ; 256 Helen Way, Livermore, CA 94550 (US). (74) Agents: HSUE, James, S. et al.; Majestic, Parsons, Siebert & Hsue, Four Embarcadero Center, Suite 1450, San Francisco, CA 94111-4121 (US).</p>		<p>(81) Designated States: AT (European patent), BE (European patent), CH (European patent), DE (European patent), DK (European patent), ES (European patent), FR (European patent), GB (European patent), GR (European patent), IT (European patent), JP, KR, LU (European patent), MC (European patent), NL (European patent), SE (European patent).</p> <p>Published <i>With international search report.</i></p>

(54) Title: SEMICONDUCTOR CHIP COOLING APPARATUS



(57) Abstract

A novel semiconductor chip cooling apparatus (10) includes at least one semiconductor die (12) packaged according to a TAB design. A support structure (14) supports the die (12), and a dike (22) is connected to the support structure (14) and the TAB tape (20) to form a cavity (34) impervious to liquid and air. Input (24) and output (26) means are connected to the cavity (34). Fluid means circulate throughout the cavity (34) and utilize the input (24) and output (26) means to directly cool the die (12) during operation of the semiconductor die (12). Heat spreading means (32) may be positioned below the die (12) to increase the amount of surface area which contacts the fluid means, thereby cooling the die (12) more efficiently.

FOR THE PURPOSES OF INFORMATION ONLY

Codes used to identify States party to the PCT on the front pages of pamphlets publishing international applications under the PCT.

AT	Austria	FI	Finland	MI	Mali
AU	Australia	FR	France	MN	Mongolia
BB	Barbados	GA	Gabon	MR	Mauritania
BE	Belgium	GB	United Kingdom	MW	Malawi
BF	Burkina Faso	GN	Guinea	NI	Netherlands
BG	Bulgaria	GR	Greece	NO	Norway
BJ	Benin	HU	Hungary	PL	Poland
BR	Brazil	IE	Ireland	RO	Romania
CA	Canada	IT	Italy	RU	Russian Federation
CF	Central African Republic	JP	Japan	SD	Sudan
CG	Congo	KP	Democratic People's Republic of Korea	SE	Sweden
CH	Switzerland	KR	Republic of Korea	SN	Senegal
CI	Côte d'Ivoire	LI	Liechtenstein	SU	Soviet Union
CM	Cameroon	LK	Sri Lanka	TD	Chad
CS	Czechoslovakia	LU	Luxembourg	TG	Togo
DE	Germany	MC	Monaco	US	United States of America
DK	Denmark	MG	Madagascar		
ES	Spain				

SEMICONDUCTOR CHIP COOLING APPARATUS**Background of the Invention**

This invention relates to a novel apparatus for cooling a semiconductor die. More specifically, this invention relates to an apparatus for cooling an integrated-circuit chip by circulating a cooling liquid around the chip.

In the design of optimal computer systems, it is important that the most number of integrated circuit chips are fit into the least amount of space. Integrated circuit technology has advanced so that extremely small chips can be produced which have significantly more computing power than in previous years. Chip packaging design is also an important factor affecting the size of the computer circuitry. While there are a number of advantages to decreasing the size of semiconductor chips, associated problems have also arisen. For instance, as the chip size decreases, the heat emitted from the chip becomes problematic because it is difficult to cool such a small element. The chip packaging design also affects how efficiently the chip may be cooled. As the chip temperature increases, the effective operating speed of the chip decreases. Also, it is necessary to keep the chip below a certain temperature in order to prevent damage to the chip circuitry.

Semiconductor chips are often elements in complex systems which are built from a plurality of printed circuit boards, which are themselves interconnected by other printed circuit or mother boards. The resulting system is relatively bulky and yet compact. Since the systems are compact, effective cooling systems

are needed to remove the heat which evolves during operation. Some cooling systems result in even bulkier packages which utilize valuable circuit board space.

In order to facilitate cooling, individual
5 semiconductor chips and semiconductor chip systems have been designed to permit convection about and within them. The convection may be natural or forced, and air has been used as the cooling medium. Circulating air has helped to remove some of the heat emitted from a
10 semiconductor chip, but it is oftentimes an undesirable means of doing so. Natural convection is not an efficient cooling method, and forced air convection has the disadvantage of polluting the circuits by rapidly covering them in dust.

15 Another method of cooling semiconductor chips is to circulate a liquid around a chip. A cooling liquid cools the chip more efficiently than air and obviates the problems associated with air convection. While the liquid cooling systems that have been developed
20 are an improvement over air convection systems, a semiconductor die sometimes remains at an undesirable temperature because the circulating fluid cannot absorb enough heat to adequately cool the chip. More specifically, the fluid flow may not be evenly distributed
25 around the chip. Additionally, temperature gradients may exist on the chip surface, thereby causing the chip to operate improperly.

Some prior art devices utilizing liquid for cooling have included complex structures which are
30 difficult to fabricate. One type of arrangement, as shown in U.S. Patent 4,547,834 to Dumont et al., includes a plurality of levels to support a semiconductor chip and permit cooling of the chip. Some of the levels are separated to form an opening through which
35 the liquid circulates to cool the semiconductor die. A plurality of column supporters hold up a layer of metal

under which the liquid circulates. This arrangement is unsatisfactory because it is complex, expensive, and somewhat difficult to fabricate.

5 Semiconductor chip cooling arrangements must additionally take into account the type of die packaging. For example, the die may be packaged utilizing a common packaging design called tape automated bonding (TAB). TAB, a replacement for wire bonding, utilizes a tape having leads fabricated on its surface. The tape
10 is connected to the die so that the leads may be bonded to the appropriate die surfaces. TAB is a useful packaging method because it is simple and reliable.

Another cooling package is described in U.S. Patent 4,748,495 to Kucharek, and includes a structure
15 having a coolant path through a heat sink. The heat sink is adjacent to a heat spreader, which is adjacent to the top surface of an IC chip. Heat emitted from the IC chip is transferred to the heat sink via the heat spreader by means of a cooling liquid. The heat sink
20 structure is somewhat complex and includes a plurality of parallel channels through which the liquid flows. Kucharek mentions that the structure may be adaptable for chips having tape automated bonded (TAB) contacts. While the package reduces the temperature of the IC chip
25 more than air convection units, the complexity and accompanying cost of the unit are undesirable. Additionally, the package is bulky and takes up valuable circuit-board space. Other types of packaging arrangements include similarly complex designs which are
30 expensive to fabricate.

The difficulties suggested in the preceding are not intended to be exhaustive, but rather are among many which may tend to reduce the usefulness of prior semiconductor chip cooling apparatus. Other noteworthy
35 problems may also exist; however, those presented above should be sufficient to demonstrate that semiconductor

chip cooling apparatus appearing in the past will admit to worthwhile improvement.

It is therefore a general object of the invention to provide a novel semiconductor chip cooling apparatus which will obviate or minimize difficulties of the type previously described.

It is a specific object of the invention to provide a semiconductor chip cooling apparatus which will efficiently cool a semiconductor chip.

It is another object of the invention to provide an apparatus for cooling a semiconductor chip which is packaged using tape automated bonding (TAB) techniques.

It is still another object of the invention to provide a semiconductor chip cooling apparatus which is compact.

It is yet another object of the invention to provide a semiconductor chip cooling apparatus which is relatively simple to manufacture, inexpensive, and reliable.

Summary of the Invention

The present invention is directed to an integrated-circuit cooling apparatus which includes at least one semiconductor die having bond pads and being connected to a tape having leads. The tape is positioned next to the die to permit electrical connections between the leads and the bond pads. The apparatus includes a support structure having a surface for supporting the die, and a dike connected to the surface and the tape. The dike surrounds the die to form, with the tape and the surface, a cavity impervious to air or liquid. An input means and outputs means are connected to the cavity. Fluid means utilize the input means and output means to circulate throughout the cavity and reduce the temperature of the die and the support

structure by directly contacting at least a portion of each of them.

Description of the Drawings

Other advantages of the present invention will become apparent from the following detailed description of a preferred embodiment thereof, taken in conjunction with the accompanying drawings, wherein:

Figure 1 is an axonometric view of the integrated-circuit dynamic cooling apparatus of the present invention;

Figure 2 is a side elevational view showing the integrated-circuit dynamic cooling apparatus of the present invention;

Figure 3 is an exploded view of individual components of the subject invention prior to assembly; and

Figure 4 is a plan view of the apparatus as shown in Figure 1.

Detailed Description of the Invention

Referring now to the drawings, wherein like numerals indicate like parts, and initially to Figure 1, there will be seen an integrated-circuit cooling apparatus 10 which includes a semiconductor die 12 packaged according to a tape automated bonding (TAB) design. The die 12 rests upon a printed circuit board 14 having a plurality of bond pads 16. The die 12 is electrically connected to the printed circuit board 14 via leads 18 which are fabricated on a TAB tape 20. A dike 22 is connected to the printed circuit board 14 and the TAB tape 20 to form a cavity, and surrounds the semiconductor die 12 as shown. The dike forms an impermeable barrier around the die 12 so that a cooling liquid (not visible) may be circulated around the die 12 to reduce its temperature. The cooling liquid enters the cavity

through an input port 24 and exits the cavity through an exit port 26; both ports are within the perimeter of the dike 22. The TAB tape is sealed on its top by an encapsulant 28, making the cavity impervious to liquid or air.

5
10
15
20
25
30

Figure 2 shows a side elevational view of the instant invention and will facilitate an understanding of the compact design of the integrated-circuit cooling apparatus 10. More specifically, the die 12 includes bond pads 30 on its surface, each bond pad being connected to a lead 18, as shown. The leads 18 are attached to the TAB tape 20 and are positioned over the top side of the dike 22. The encapsulant 28 (shown by the shaded areas in Figure 2) isolates the electrical connections at the bond pads 20 from the cooling liquid, which flows through cavity 34. The die 12 sits upon a heat spreader 32 which increases the heated surface area coming into contact with the cooling liquid and is attached to the printed circuit board 14 as shown. The heat spreader 32 is formed of a heat conducting material and is connected to the semiconductor die 12 by a heat conducting glue 36. Since the heat spreader sits adjacent to the semiconductor die 12, heat emitted from the die during its operation will transfer to the heat spreader 32. When the cooling liquid circulates, heat will be quickly transferred to and absorbed by the liquid because a large amount of heated surface area (*i.e.* the heat spreader) will contact the liquid. Additionally, the cooling liquid directly contacts the semiconductor die 12. Thus, the die will be cooled faster than prior art assemblies lacking a heat spreader 32.

35

The cooling liquid enters the cavity 34 through input port 24 which is coupled to an external fluid source, not shown. The fluid is circulated around the die 12 to absorb heat and exits the cavity 34 through

the output port 26. The cooling liquid may be water, freon, other fluoroinerts, or any other suitable liquid. The temperature of the die will usually be less than 110°C so that the cooling liquid will not vaporize. The dike 22 is formed out of a heat insulating material such as a plastic. The dike can also be formed out of metal, but plastic may be less expensive. The encapsulant 28 may be formed from a silicone based or other type of plastic. A flexible thermoplastic glue 25 secures the dike 22 to the TAB tape and maintains the cooling fluid integrity by permitting some amount of expansion within the cavity.

In an alternate embodiment, the dike 22 may include a bore 23 (indicated by dotted lines) there-through, such that the cooling liquid is input to the cavity 34 through the bore. More specifically, input and output hoses (not shown) may be attached to the bore 23 and positioned at the corner of the die, as shown in dotted lines by the bore 23 in Figure 4. This arrangement would obviate the need for the input port 24 and output port 26, as well as the portion of the cavity 34 below the printed circuit board 14. Inclusion of two bores 23 at opposite sides of the dike 22 might be useful in some applications of the integrated-circuit cooling apparatus 10, including those where optimal space utilization is not crucial. Another application might be one in which only a single die needs to be cooled.

Figure 3 shows the components of the integrated-circuit cooling apparatus 10 prior to assembly. The fabrication process is relatively simple and inexpensive because the components may be easily glued together. The printed circuit board 14, which may be of a flexible material, is pre-fabricated to include the heat spreader 32, the input port 24 and the output port 26. The dike 22 is then glued to the circuit board so that the

input/output ports and the heat spreader 32 are within the perimeter of the dike. Again, the heat spreader 32 is composed of a heat conducting material and the dike 22 is composed of a heat insulating material. The semiconductor die 12, having a plurality of bond pads 30 connected thereon, is glued to the center of the heat spreader 32. The TAB tape 20, which is usually prefabricated to include the encapsulant 28, is placed on top of the semiconductor die such that the leads 18 are adjacent to the corresponding bond pad 30 on the die 12. The leads 18 are bonded to the bond pads 16. Alternatively, the encapsulant 28 may be placed over the die 12 to form a closed cavity if the TAB tape is not prefabricated to include the encapsulant. A compression device heats the package surface and causes an adhesive on the surface of the dike 22 to bond to the leads 18, making the cavity 34 impervious to liquid or air.

The assembly procedure for the integrated-circuit cooling apparatus may be performed sequentially as described above or may be done in a single step. It is apparent that the fabrication process is simpler, and therefore more economical and efficient, than the systems of the prior art. While the invention has been described with reference to a single semiconductor die, it will be understood that the invention includes multi-chip applications, wherein many semiconductor chip assemblies are interconnected and cooperatively cooled. For instance, a plurality of semiconductor chips may be positioned within the perimeter of a single dike, permitting a cooling liquid to sequentially circulate among many chips within a single package.

Figure 4 is a top plan view of an integrated-circuit cooling apparatus 10. The apparatus shown in this figure has more leads 18 than the apparatus shown in Figure 1, but is the essentially the same otherwise. Note that the input/output ports 24, 26 are positioned

between the dike 22 and the heat spreader 32 to maximize the amount of surface area upon which the liquid coolant is circulated. The input port 24 and output port 26 may be positioned at opposing ends of the die 12, or may alternatively be positioned near each other. If the ports are close to each other, a manifold current divider (not shown) could be used to control the flow of the liquid coolant. As discussed above, it is important to ensure an even flow of liquid coolant so that the temperature of the die is equal on all surfaces. The input/output ports may therefore be positioned as described to ensure that the coolant circulates evenly throughout the cavity 34. Positioning of the input/output ports also depends on the fluid flow rates, the power used by the die, and the particular cooling fluid used. Alternately, the dike may include a bore 23. In this arrangement, the cooling fluid would enter and exit the bores via external hoses connected to the bores and positioned between the leads 18. The effect of the cooling liquid is an improvement over the prior art because the semiconductor die 12 is directly contacted by the cooling liquid, thereby improving cooling efficiency, but not affecting the electrical connections to the die.

After reading and understanding the foregoing inventive integrated-circuit cooling apparatus, in conjunction with the drawings, it will be appreciated that several distinct advantages of the subject invention are obtained. Without attempting to set forth all of the desirable features of the instant invention, at least some of the major advantageous features of the invention include the use of heat spreader, which increases the amount of heat surface area contacted by the cooling fluid. Since the semiconductor die 12 is directly contacted by the cooling liquid, the transfer of heat from the die to the liquid is optimal. The dike 22 is

simple to fabricate and reliably contains the cooling fluid within the cavity 34. The locations of the input port 24 and output port 26 insure that there is uniform flow of the cooling liquid. The configuration is also space effective because the height of the entire package above the printed circuit board does not increase in comparison to TAB packages which do not include the cooling feature of the present invention. The integrated-circuit cooling apparatus is simple and inexpensive; compact, and may be conveniently used in conjunction with a TAB-packaged semiconductor chip.

It should be noted that although the invention has been described with reference to specific embodiments, it should not be construed to be so limited. For example, while the use of a heat spreader is advantageous, it is not essential for the invention. The input and output ports may also be connected to cavity 34 in a manner different from those shown. Those skilled in the art and familiar with the instant disclosure of the subject invention may recognize additions, deletions, modifications, substitutions and other changes which will fall within the purview of the subject invention and claims.

What Is Claimed Is:

1. An integrated-circuit cooling apparatus, said apparatus comprising:

at least one semiconductor die having bond pads fabricated thereon, said die being connected to a tape
5 having leads fabricated thereon, said tape being positioned next to said at least one semiconductor die to permit electrical connections between said leads and said bond pads on said die;

a support structure having a surface for
10 supporting said die;

a dike connected to said surface and said tape, said dike surrounding said semiconductor die to form with said tape and said surface a cavity impervious to air and liquid; and

15 input means and output means connected to said cavity; and

fluid means for cooling said semiconductor die, said fluid means circulating throughout said cavity and utilizing said input means and said output means to
20 reduce the temperature of said die and said support structure during operation of said die by directly contacting at least a portion of said die and said support structure.

2. The integrated-circuit cooling apparatus as claimed in claim 1 wherein said input means and said output means are respectively an input port and an output port.

3. The integrated-circuit cooling apparatus as claimed in claim 2 wherein said input port and said output port are fabricated through said surface, said ports being in communication with said cavity.

4. The integrated-circuit cooling apparatus as claimed in claim 1 and further including heat spreading means for distributing heat emitted from said die, said heat spreading means being connected to said semiconductor die to permit heat transfer between said heat spreading means and said die.

5. The integrated-circuit cooling apparatus as claimed in claim 4 wherein said heat spreading means is composed of a heat conducting material.

6. The integrated-circuit cooling apparatus as claimed in claim 4 wherein said heat spreading means further comprises a plate having a surface area which is larger than the surface area of said semiconductor die.

7. The integrated-circuit cooling apparatus as claimed in claim 1 wherein said support structure comprises a printed circuit board.

8. The integrated-circuit cooling apparatus as claimed in claim 1 wherein said cooling means includes a cooling liquid which is circulated around said semiconductor die and adjacent to said support structure to thereby reduce the temperature of said die.

9. The integrated-circuit cooling apparatus as claimed in claim 8 wherein said cooling liquid includes water.

10. The integrated-circuit cooling apparatus as claimed in claim 1 wherein said dike is composed of a heat insulating material.

11. The integrated-circuit cooling apparatus as claimed in claim 1 wherein said dike is connected to said TAB tape by means of a flexible thermoplastic glue.

12. The integrated-circuit cooling apparatus as claimed in claim 7 wherein said printed circuit board comprises a flexible printed circuit board.

13. The integrated-circuit cooling apparatus as claimed in claim 1, said apparatus comprising a plurality of semiconductor dies supported by said surface and connected to said tape, such that said dike
5 surrounds said plurality of semiconductor dies to permit cooling of said dies.

14. The integrated-circuit cooling apparatus as claimed in claim 8 wherein said cooling liquid includes freon and other fluoroinerts.

15. An integrated-circuit cooling apparatus, said apparatus comprising:

at least one semiconductor die having bond pads fabricated thereon, said die being connected to a tape
5 having leads fabricated thereon, said tape being positioned next to said at least one semiconductor die to permit electrical connections between said leads and said bond pads on said die;

a support structure having a surface for
10 supporting said die;

a dike connected to said support structure and said tape, said dike including at least one bore to permit a fluid to flow therethrough, said dike surrounding said semiconductor die to form a cavity impervious
15 to air and liquid except through said at least one bore;

input means and output means connected to said cavity; and

fluid means for cooling said semiconductor die,
said fluid means circulating throughout said cavity and
20 utilizing said input means and said output means to
reduce the temperature of said die and said support
structure during operation of said die by directly
contacting at least a portion of said die and said
support structure.

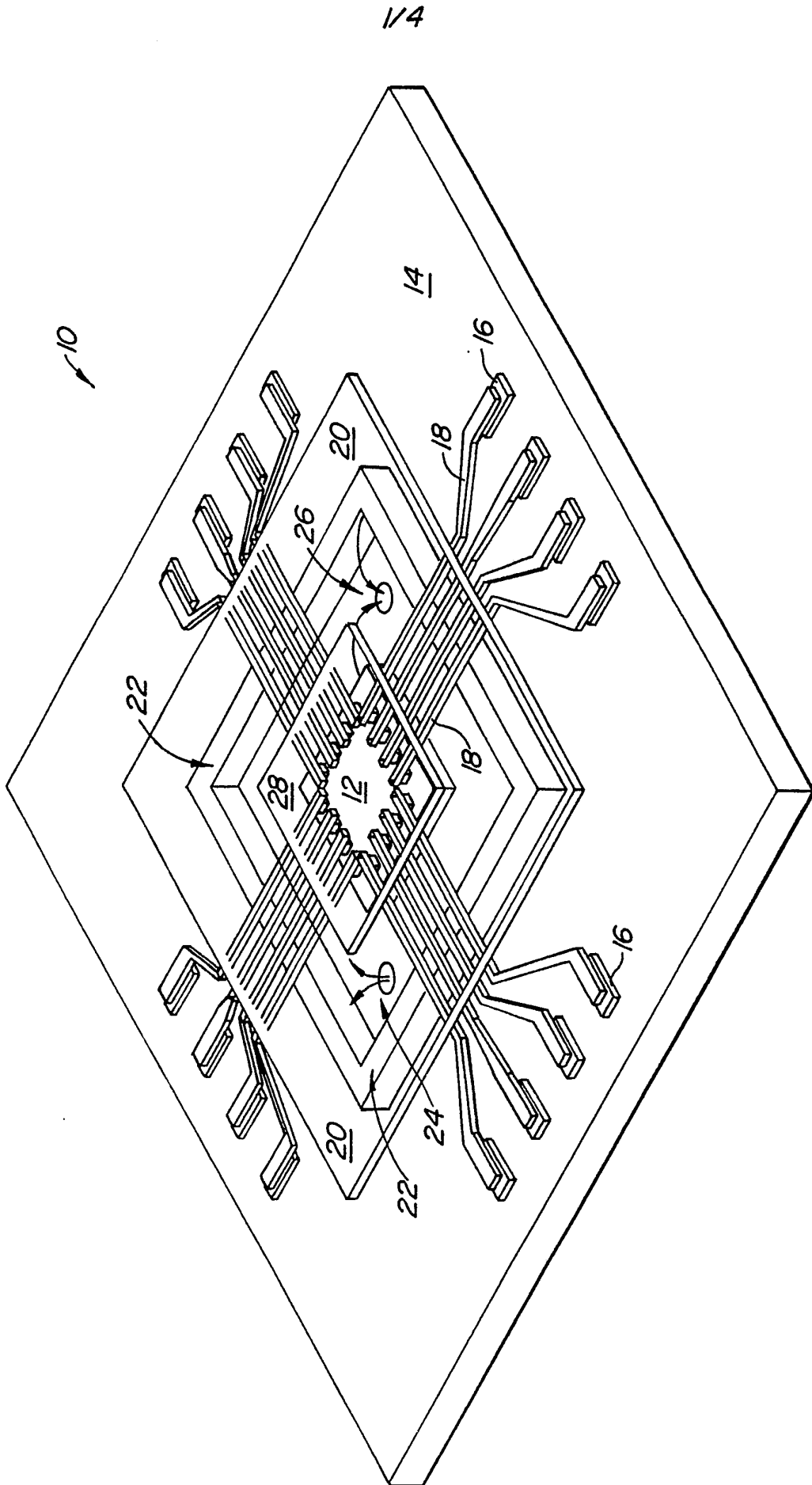

1/4

FIG. 1.

SUBSTITUTE SHEET

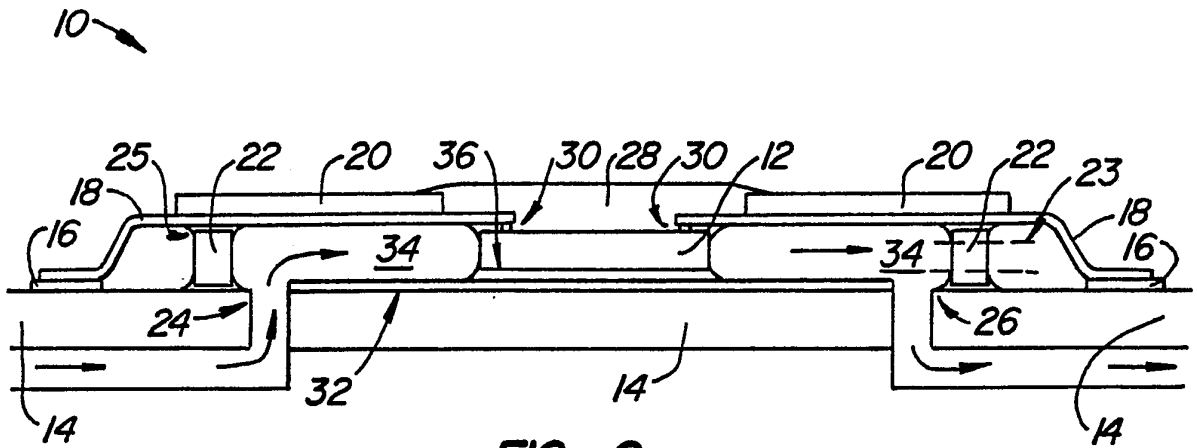

FIG. 2.

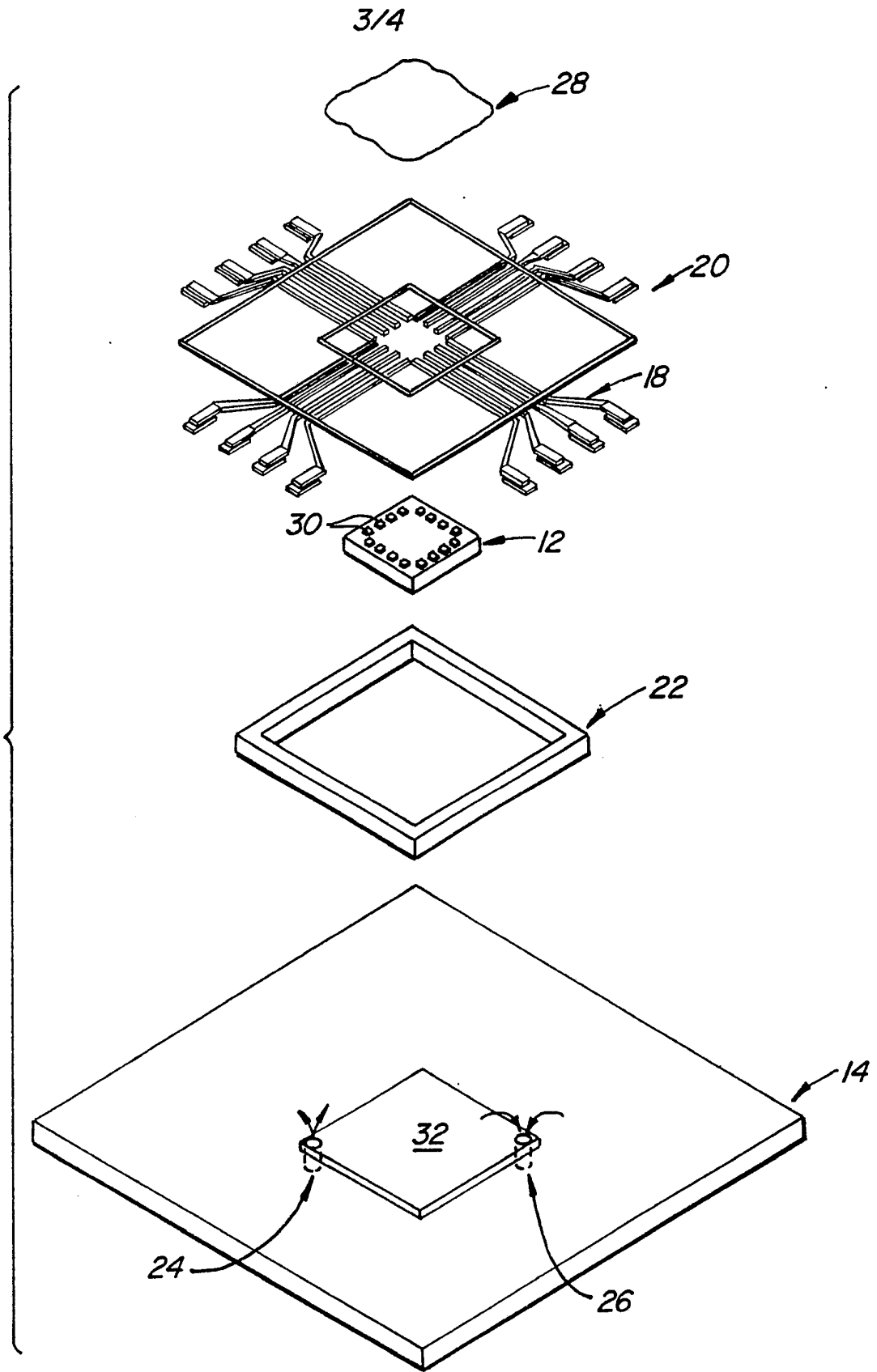

FIG. 3.

SUBSTITUTE SHEET

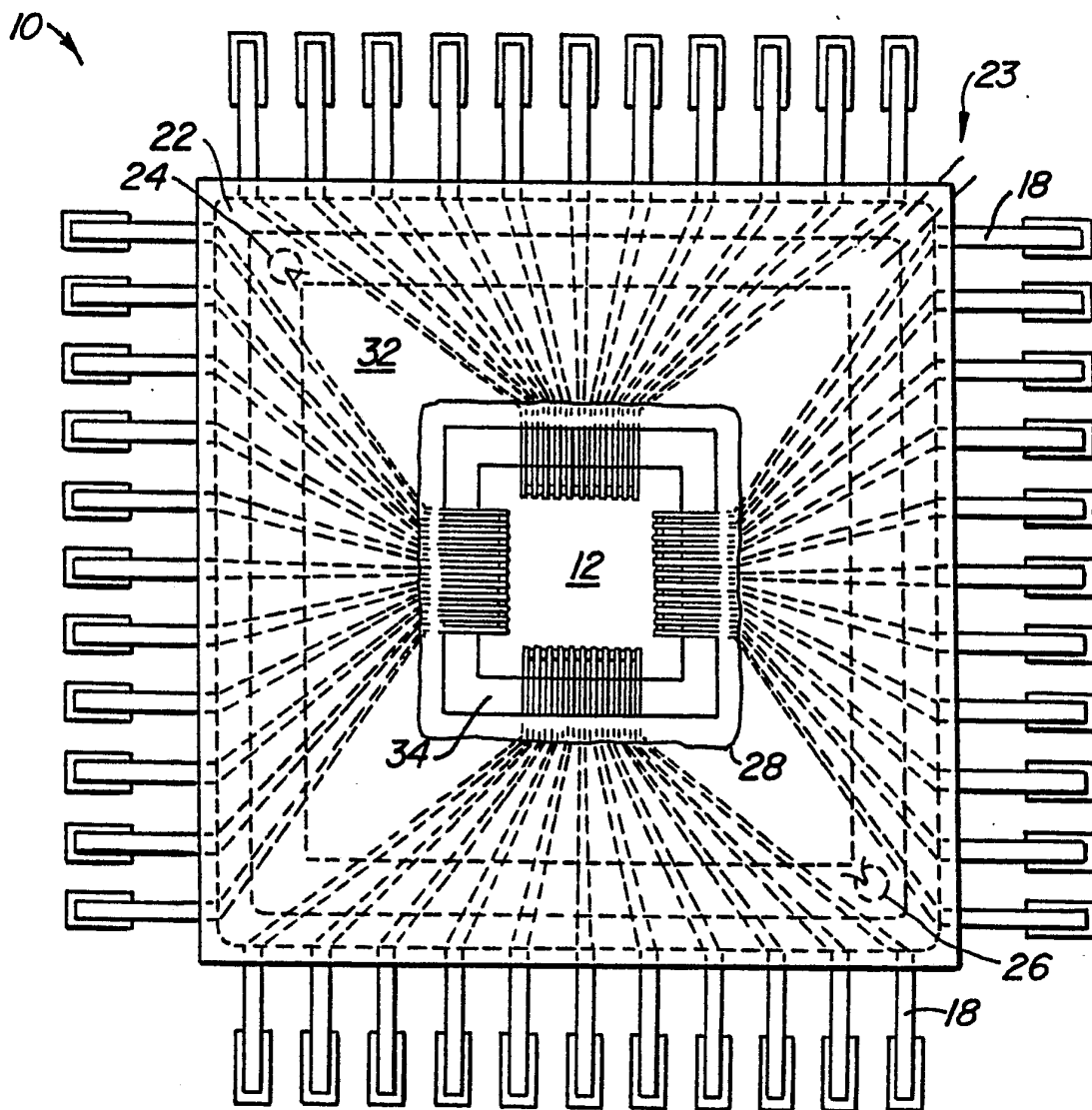

FIG. 4.

INTERNATIONAL SEARCH REPORT

international application No.
PCT/US92/03486

A. CLASSIFICATION OF SUBJECT MATTER

IPC(5) :H01L 23/48,3902,25/04; H02B 1/00; H05K 7/20
US CL :357/70,80,82; 361/382,388

According to International Patent Classification (IPC) or to both national classification and IPC

B. FIELDS SEARCHED

Minimum documentation searched (classification system followed by classification symbols)

U.S. : 357/74,81; 361/385

Documentation searched other than minimum documentation to the extent that such documents are included in the fields searched

Electronic data base consulted during the international search (name of data base and, where practicable, search terms used)

APS: Fluid, Cooling, Die, Dike, Cavity, Semiconductor, IC, Integrated Circuit, Tape, TAB

C. DOCUMENTS CONSIDERED TO BE RELEVANT

Category*	Citation of document, with indication, where appropriate, of the relevant passages	Relevant to claim No.
Y	US, A, 4,748,495 (KUCHAREK) 31 May 1988, See col. 17 and 18.	1-15
Y	US, A, 3,365,620 (BUTLER ET AL.) 23 January 1968, See abstract and claim 1.	1-15
A,P	US, A, 5,053,853 (HAJ-ALI-AHMADI ET AL.) 01 October 1991, See abstract.	1-15
A,P	US, A,5,065,279 (LAZENBY ET AL.) 12 November 1991, See abstract.	1-15
A,P	US, A, 5,031,025 (BRAUN ET AL.) 09 July 1991, See claims 1-7.	1-15
A	US, A, 4,186,422 (LAERMER) 29 January 1980, See abstract.	1 and 15
A	US, A, 4,547,834 (DUMONT ET AL.) 15 October 1985, See claims 1 and 6.	1 and 15
A	US, A, 3,706,010 (AERMER ET AL.) 12 December 1972, See col. 1, lines 15-35.	1 and 15
A	FR, A, 2,266,427 (BONNEFOY) 24 October 1975, See fig. 1-4.	1

Further documents are listed in the continuation of Box C. See patent family annex:

* Special categories of cited documents:	"T"	later document published after the international filing date or priority date and not in conflict with the application but cited to understand the principle or theory underlying the invention
"A" document defining the general state of the art which is not considered to be part of particular relevance	"X"	document of particular relevance; the claimed invention cannot be considered novel or cannot be considered to involve an inventive step when the document is taken alone
"E" earlier document published on or after the international filing date	"Y"	document of particular relevance; the claimed invention cannot be considered to involve an inventive step when the document is combined with one or more other such documents, such combination being obvious to a person skilled in the art
"L" document which may throw doubts on priority claim(s) or which is cited to establish the publication date of another citation or other special reason (as specified)	"&"	document member of the same patent family
"O" document referring to an oral disclosure, use, exhibition or other means		
"P" document published prior to the international filing date but later than the priority date claimed		

Date of the actual completion of the international search 06 AUGUST 1992	Date of mailing of the international search report 16 SEP 1992
Name and mailing address of the ISA/ US Commissioner of Patents and Trademarks Box PCT Washington, D.C. 20231 Facsimile No. NOT APPLICABLE	Authorized officer In DAVID M. OSTROWSKI NGUYEN NGOC-HO INTERNATIONAL DIVISION Telephone No. (703) 308-4108