

(12) STANDARD PATENT
(19) AUSTRALIAN PATENT OFFICE

(11) Application No. **AU 2001255423 C1**

(54) Title
Method and system for categorizing items in both actual and virtual categories

(51) International Patent Classification(s)
G06F 17/30 (2006.01)

(21) Application No: **2001255423** (22) Date of Filing: **2001.04.16**

(87) WIPO No: **WO01/82107**

(30) Priority Data

(31) Number	(32) Date	(33) Country
09/733,767	2000.12.08	US
60/199,731	2000.04.24	US

(43) Publication Date: **2001.11.07**

(43) Publication Journal Date: **2002.01.24**

(44) Accepted Journal Date: **2006.03.16**

(44) Amended Journal Date: **2006.11.30**

(71) Applicant(s)
Ebay, Inc.

(72) Inventor(s)
Seamon, Joseph

(74) Agent / Attorney
Freehills Patent & Trade Mark Attorneys, Level 38 MLC Centre Martin Place, Sydney, NSW, 2000

(56) Related Art
US5802511

(12) INTERNATIONAL APPLICATION PUBLISHED UNDER THE PATENT COOPERATION TREATY (PCT)

(19) World Intellectual Property Organization
International Bureau



(43) International Publication Date
1 November 2001 (01.11.2001)

PCT

(10) International Publication Number
WO 01/82107 A1

- (51) International Patent Classification⁷: **G06F 17/00**
- (21) International Application Number: PCT/US01/12398
- (22) International Filing Date: 16 April 2001 (16.04.2001)
- (25) Filing Language: English
- (26) Publication Language: English
- (30) Priority Data:
60/199,731 24 April 2000 (24.04.2000) US
09/733,767 8 December 2000 (08.12.2000) US
- (71) Applicant (for all designated States except US): **EBAY, INC.** [US/US]; 2125 Hamilton Avenue, San Jose, CA 95125 (US).
- (72) Inventor; and
- (75) Inventor/Applicant (for US only): **SEAMON, Joseph** [US/US]; 2886 Urzi Court, San Jose, CA 95135 (US).
- (74) Agents: **MALLIE, Michael, J.** et al.; Blakely, Sokoloff, Taylor & Zafman LLP, 7th floor, 12400 Wilshire Boulevard, Los Angeles, CA 90025 (US).
- (81) Designated States (national): AE, AG, AL, AM, AT, AU, AZ, BA, BB, BG, BR, BY, BZ, CA, CH, CN, CO, CR, CU, CZ, DE, DK, DM, DZ, EE, ES, FI, GB, GD, GE, GH, GM, HR, HU, ID, IL, IN, IS, JP, KE, KG, KP, KR, KZ, LC, LK, LR, LS, LT, LU, LV, MA, MD, MG, MK, MN, MW, MX, MZ, NO, NZ, PL, PT, RO, RU, SD, SE, SG, SI, SK, SL, TJ, TM, TR, TT, TZ, UA, UG, US, UZ, VN, YU, ZA, ZW.
- (84) Designated States (regional): ARIPO patent (GH, GM, KE, LS, MW, MZ, SD, SL, SZ, TZ, UG, ZW), Eurasian patent (AM, AZ, BY, KG, KZ, MD, RU, TJ, TM), European patent (AT, BE, CH, CY, DE, DK, ES, FI, FR, GB, GR, IE, IT, LU, MC, NL, PT, SE, TR), OAPI patent (BF, BI, CF, CG, CI, CM, GA, GN, GW, ML, MR, NE, SN, TD, TG).
- Published:**
— with international search report
— before the expiration of the time limit for amending the claims and to be republished in the event of receipt of amendments
- For two-letter codes and other abbreviations, refer to the "Guidance Notes on Codes and Abbreviations" appearing at the beginning of each regular issue of the PCT Gazette.



WO 01/82107 A1

(54) Title: METHOD AND SYSTEM FOR CATEGORIZING ITEMS IN BOTH ACTUAL AND VIRTUAL CATEGORIES

(57) Abstract: A method for facilitating location of a data item describing, for example, a product or service that is the subject of on-line auction, commences with the presentation of a category navigation interface. The category navigation interface allows a user to navigate a "virtual" hierarchy of categories and to select a target virtual category of the virtual hierarchy. The target virtual category is then identified as being linked to an actual category, within an actual hierarchy of categories. Database items are classified only in terms of the real hierarchy of categories, and not the virtual hierarchy of categories. Having then identified an actual category to which the virtual category is mapped, data items of the real category are identified responsive to the user selection of the virtual category of the virtual hierarchy of categories.

METHOD AND SYSTEM FOR CATEGORIZING ITEMS IN BOTH ACTUAL AND VIRTUAL CATEGORIES

[0001] The present application claims priority from U.S. provisional patent application number 60/199,731 entitled "Method and System for Categorizing Items in Both Actual and Virtual Categories" filed April 24, 2000.

FIELD OF THE INVENTION

5 [0002] The present invention relates generally to the field of database architecture and, more specifically, to the categorizing of database items in both an actual category and a virtual category.

BACKGROUND OF THE INVENTION

0 [0003] Web sites, or other network-based data aggregators or presenters, commonly use category schemas to provide context and structure for data items. For example, within an on-line web site directory, such as that presented by Yahoo! Incorporated of Santa Clara, California, web sites are commonly classified under an extensive category schema. Within commercial web sites, product or service offerings are also commonly classified under a category schema so as to enable convenient user navigation of offerings to locate offerings of interest. For example, eBay, Incorporated of San Jose, California, implements an extensive categorization schema for an on-line auction service. Specifically, a
5 seller wishing to post an item for auction on the on-line auction facility is required to specify a category for the relevant product offering.

SUMMARY OF THE INVENTION

[0004] In a first aspect of the present invention there is provided a method of constructing a category structure within a database, the method including:

20 defining a first structure of categories to classify a data item, the first structure including at least a first category;

defining a second structure of categories to provide an alternative classification of the data item, the second structure including at least a second category;

25 defining the first structure of categories as a first hierarchy of categories and defining the second structure of categories as an alternative second hierarchy of categories, wherein the second category is associated with the first category, the first category comprises a first category path defined in terms of the

defining the first structure of categories as a first hierarchy of categories and defining the second structure of categories as an alternative second hierarchy of categories, wherein the second category is associated with the first category, the first category comprises a first category path defined in terms of the first structure of categories and the second category comprises a second category path defined in terms of the second structure of categories, the first category path including a first plurality of categories that are respectively associated with a first plurality of category identifiers and the second category path including a second plurality of categories that are respectively associated with a second plurality of category identifiers.

5 [0005] In a further aspect of the present invention there is provided a method of classifying a data item within a database, the method including:

identifying a first category, of a first hierarchy of categories, attributed to a data item;

automatically attributing a second category, of a second alternative hierarchy of categories, to the data item, wherein the first and second categories are defined by respective category paths of the first and second hierarchies of categories, the first category path including a first plurality of categories that are respectively associated with a first plurality of category identifiers and the second category path including a second plurality of categories that are respectively associated with a second plurality of category identifiers.

15 [0006] In still another aspect of the present invention there is provided a method of facilitating location of a data item within a database, the method including:

facilitating user-navigation of a first category structure to select a first category; identifying a second category of a second category structure as being linked to the first category of the first category structure; and

25 identifying data items of the second category responsive to the selection of the first category of the first category structure,

wherein the first and second category structures comprise respective first and second hierarchies of categories, and

5 wherein the first and second categories are defined by respective category paths of the first and second hierarchies of categories, the first category path including a first plurality of categories that are respectively associated with a first plurality of category identifiers and the second category path including a second plurality of categories that are respectively associated with a second plurality of category identifiers, wherein the first category structure includes a first hierarchy of categories and the second category structure includes a second alternative hierarchy of categories.

0 **[006A]**In still another aspect of the present invention there is provided a machine-readable medium storing a sequence of instructions that, when executed by a machine, cause the machine to:

identify a first category, of a first hierarchy of categories, attributed to a data item; and

automatically attribute a second category, of a second hierarchy of categories, to the data item,

5 wherein the first and second categories are defined by respective category paths of the first and second hierarchies of categories, the first category path including a first plurality of categories that are respectively associated with a first plurality of category identifiers and the second category path including a second plurality of categories that are respectively associated with a second plurality of category identifiers.

10 **[006B]**In still a further aspect of the present invention there is provided a machine-readable medium storing a sequence of instructions that, when executed by a machine, cause the machine to:

facilitate user-navigation of the first category structure to select the first category;

identify a second category of a second category structure as being linked to the first category of the first category structure; and

identify data items of the second category responsive to the selection of the first category of the first category structure, wherein the first and second category structures comprise respective first and second hierarchies of categories, and

5 wherein the first and second categories are defined by respective category paths of the first and second hierarchies of categories, the first category path including a first plurality of categories that are respectively associated with a first plurality of category identifiers and the second category path including a second plurality of categories that are respectively associated with a second plurality of category identifiers, wherein the first category structure includes a first hierarchy of categories and the second category
10 structure includes a second alternative hierarchy of categories.

[0007] It will also be understood that the term "comprising" (or its grammatical variants) as used in this specification is equivalent to the term "including" and should not be taken as excluding the presence of other elements or features.

BRIEF DESCRIPTION OF THE DRAWINGS

15 [0008] The present invention is illustrated by way of example and not limitation in the figures of the accompanying drawings, in which like references indicate similar elements and in which:

[0009] **Figure 1** is a block diagram illustrating an exemplary network-based transaction facility in the form of an internet-based auction facility 10.

20 [0010] **Figure 2** is a database diagram illustrating an exemplary database, maintained and accessed via a database engine server, which at least partially implements and supports the auction facility.

[0011] **Figure 3** is a representation of an item table, according to an exemplary embodiment of the present invention, that may include a category identifier
25 corresponding to an identifier of one or more real categories defined within a category table of the database.

[0012] **Figure 4** is a diagrammatic representation of an exemplary category table, and of an exemplary category class, that may be instantiated as objects that reference a

category table.

[0012] **Figure 5** is a diagrammatic representation of an exemplary populated category table, which is populated with exemplary records from both an actual category as well as two virtual categories.

[0013] **Figure 6** is a conceptual diagram illustrating a view of selected actual categories and virtual categories within an exemplary database, as defined within one or more exemplary category tables.

[0014] **Figure 7** is a flow chart illustrating a method, according to an exemplary embodiment of the present invention, of constructing a category structure within a database.

[0015] **Figure 8** is a flow chart detailing a method, according to an exemplary embodiment of the present invention, of facilitating the location of a data item by navigation of a hierarchy of virtual categories.

[0016] **Figure 9A** provides an example of a markup language document that lists a number of top-level virtual categories.

[0017] **Figure 9B** illustrates an example of a markup language document that may present an exemplary list of mixed-level categories.

[0018] **Figure 9C** is an example of a markup language document that may be utilized to present both next level, or leaf, categories and data items identified to a user.

[0019] **Figure 9D** illustrates a user interface, according to an exemplary embodiment of the present invention, to present a narrowed list of data items.

[0020] **Figure 10A** shows an exemplary user interface, in the form of a markup language document, that facilitates classification by a user of a data item according to actual categories.

[0021] **Figures 10B - 10E** illustrate a further interface via which a user may specify actual category information.

[0022] **Figure 11** is a diagrammatic representation of a machine, in the exemplary form of a computer system, within which a set of instructions for causing the machine to perform any of the methodologies discussed above may be executed.

DETAILED DESCRIPTION

[0023] A method and system for categorizing items in both actual and virtual categories are described. In the following description, for purposes of explanation, numerous specific details are set forth in order to provide a thorough understanding of the present invention. It will be evident, however, to one skilled in the art that the present invention may be practiced without these specific details.

Terminology

[0024] For the purposes of the present specification, the term "transaction" shall be taken to include any communications between two or more entities and shall be construed to include, but not be limited to, commercial transactions including sale and purchase transactions, auctions and the like.

[0025] The term "virtual category" shall be understood to be a category that, for a particular data item, is not directly recorded as being associated with the data item. Nonetheless, a "virtual category" may, for a further data item, be directly recorded as an appropriate category, and for such a further data item will comprise an "actual category" (or a "real category").

Transaction Facility

[0026] Figure 1 is block diagram illustrating an exemplary network-based transaction facility in the form of an Internet-based auction facility 10. While an exemplary embodiment of the present invention is described within the context of an auction facility, it will be appreciated by those skilled in the art that the invention will find application in many different types of computer-based, and network-based, commerce facilities.

[0027] The auction facility 10 includes one or more of a number of types of front-end servers, namely page servers 12 that deliver web pages (e.g., markup language documents), picture servers 14 that dynamically deliver images to be displayed within Web pages, listing servers 16, CGI servers 18 that provide an intelligent interface to the back-end of facility 10, and search servers 20 that handle search requests to the facility 10. E-mail servers 21 provide, *inter alia*, automated e-mail communications to users of the facility 10.

[0028] The back-end servers include a database engine server 22, a search index server 24 and a credit card database server 26, each of which maintains and facilitates access to a respective database.

[0029] The Internet-based auction facility 10 may be accessed by a client program 30, such as a browser (e.g., the Internet Explorer distributed by Microsoft Corp. of Redmond, Washington) that executes on a client machine 32 and accesses the facility 10 via a network such as, for example, the Internet 34. Other examples of networks that a client may utilize to access the auction facility 10 include a wide area network (WAN), a local area network (LAN), a wireless network (e.g., a cellular network), or the Plain Old Telephone Service (POTS) network.

Database Structure

[0030] Figure 2 is a database diagram illustrating an exemplary database 23, maintain by and accessed via the database engine server 22, which at least partially implements

and supports the auction facility 10. The database 23 may, in one embodiment, be implemented as a relational database, and includes a number of tables having entries, or records, that are linked by indices and keys. In an alternative embodiment, the database 23 may be implemented as collection of objects in an object-oriented database.

[0031] Central to the database 23 is a user table 40, which contains a record for each user of the auction facility 10. A user may operate as a seller, buyer, or both, within the auction facility 10. The database 23 also includes item tables 42 that may be linked to the user table 40. Specifically, the tables 42 include a seller items table 44 and a bidder items table 46. A user record in the user table 40 may be linked to multiple items that are being, or have been, auctioned via the facility 10. A link indicates whether the user is a seller or a bidder (or buyer) with respect to items for which records exist within the item tables 42.

[0032] The database 23 also includes one or more category tables 47. Each record within the category table 47 describes a respective category. In one embodiment, a specific category table 47 may describe multiple, hierarchical category structures, and include multiple category records, each of which may describe the context of a particular category within the one of the multiple hierarchical category structures. For example, the category table 47 may describe a number of real, or actual, categories to which item records, within the item tables 42, may be linked. For example, as shown in **Figure 3**, an item table 42 may include a category identifier 62 corresponding to an identifier of one or more real categories defined within the category table 47.

[0033] The category table 47 may also define a number of "virtual" hierarchical category structures that support alternative navigation paths that may be presented to a user to locate a particular item. In one embodiment, categories of a "virtual" hierarchical category structure are not directly referenced within item records within the item tables 42, but are instead linked to "real" categories. Accordingly, in one embodiment, no category identifiers 62 within the item tables 42 point directly to a "virtual" category. As will be described in further detail below, multiple virtual

categories may be linked to a single real category.

[0034] The database 23 also includes a note table 48 populated with note records that may be linked to one or more item records within the item tables 42 and/or to one or more user records within the user table 40. Each note record within the table 48 may include, *inter alia*, a comment, description, history or other information pertaining to an item being auction via the auction facility 10, or to a user of the auction facility 10.

[0035] A number of other tables are also shown to be linked to the user table 40, namely a user past aliases table 50, a feedback table 52, a feedback details table 53, a bids table 54, an accounts table 56, an account balances table 58 and a transaction record table 60.

Category Table and Hierarchical Category Structures

[0036] Figure 4 is a diagrammatic representation of an exemplary category table 47, and of an exemplary category class 70 that may be instantiated as objects that reference the category table 47.

[0037] The category table 47 is shown to include a number of fields, each of which may be populated with relevant information for a category record within the category table 47. For each category record, a marketplace field 68 indicates a particular marketplace (e.g., automobiles, computers, collectibles, etc.) within the context of the network-based auction facility 10 to which the category pertains. An identifier field 72 contains a unique category identifier for each category record. A name field 74 similarly includes a name (which need not be unique) for the relevant category.

[0038] An IS_LEAF field 76, for each category record, is populated with a character that indicates whether the relevant category is a leaf category of a particular hierarchical category structure (e.g., an actual or virtual category structure). The level1-level4 fields 78-84 record the category identifiers of categories from which a particular category depends within the context of hierarchical category structure. For example, the level1 field 78 will record the category identifier for an immediate parent category, while the level2 field 80 will record the category identifier for a grandparent

category.

[0039] An actual_category field 86 is, in one embodiment, only populated for a virtual category, and stores the category identifier of an actual (or real) category to which the relevant virtual category is linked.

[0040] Figure 5 is a diagrammatic representation of an exemplary populated category table 47, that is populated with exemplary records for both an actual category 90, as well as two virtual categories 92 and 94.

[0041] Turning first to the hierarchy of actual categories 90, a parent (passenger vehicle) category includes a "Ford" child category, the "Ford" category being indicated as a child of the "passenger car" category by inclusion of the category identifier (e.g., 50) within the level1 field 78 of the record for the "Ford" category. The "Ford" category in turn is shown to include a "Taurus" sub-category and a "Model T" sub-category. It will be noted the "Taurus" and the "Model T" categories are indicated in the IS-LEAF field 76 as being leaf categories of the hierarchy of actual categories 90. It will furthermore be noted that, for each category within the hierarchy of actual categories 90, the actual_category field 86 contains a null value, as these categories are not linked to, and do not point to, further categories.

[0042] Turning now to the hierarchy of virtual categories 92, a parent "cars" category is defined to have a "Ford" child category, that in turn is defined to have a "Taurus" child category. It will be noted that the level1 field 78 of the "Ford" category includes an identifier pointing back to the parent "cars" category.

[0043] The "Taurus" category of the virtual categories 92 is also shown, within the actual_category field 86, to include the identifier of the "Taurus" category of the actual categories 90. In this way, the virtual "Taurus" category, identified by the category identifier "8001" is linked to, or points to, the actual "Taurus" category identified by the category identifier "8000". In this way, user navigation of the hierarchy of virtual categories 92, when resulting in the selection of the virtual "Taurus" category, can be utilized to identify the category identifier for an actual "Taurus" category, that can in turn be utilized to identify records within an item table 42.

[0044] Similarly, the hierarchy of virtual categories 94 is headed by a "vintage cars" category that includes a child "Ford" category and a grandchild "Model T" category. The "Model T" category is again linked, by an appropriate category identifier within the actual_category field 86, to the actual "Model T" category of the actual categories 90.

[0045] It will furthermore be noted that, in one embodiment, only real categories are indicated in the IS_LEAF field 76 as being leaf categories.

[0046] In one embodiment of the present invention, as mentioned above, data items may only be categorized under a hierarchy of actual categories 90, and not under a hierarchy of virtual categories. It is for this reason that only actual categories may be indicated as leaf categories.

[0047] While the hierarchies of virtual categories 92 and 94 are indicated as being distinct hierarchies, these hierarchies may in fact be sub-hierarchies of a larger hierarchy of virtual categories. Nonetheless, the present application contemplates that the category table 47 may define multiple hierarchies of virtual categories, and that multiple virtual categories may be linked to, or pointed to, a single actual category.

[0048] Figure 6 is a conceptual diagram illustrating a view of selected actual categories 100 and virtual categories 102 within an exemplary database, and as defined within one or more exemplary category tables 47. As illustrated, both the actual categories 100 and the virtual categories 102 are shown to include parent, child and grandchild categories. The grandchild categories, in the illustrated example, are "leaf" categories for both the actual and virtual categories 100 and 102. Leaf categories of the virtual categories are shown to be linked to appropriate "leaf" categories of the actual categories 100.

Methodologies

[0049] Figure 7 is a flow chart illustrating a method 110, according to an exemplary embodiment of the present invention, of constructing category structures within a database. The database may, in one exemplary embodiment, support a web site that

classifies data items for presentation to a user via a browser. Such data items may describe, for example, web sites, products, services or any other items that may be categorized so as to facilitate convenient location by a user. In one embodiment, the data items may describe goods and services that are offered for sale via an auction process by the network-based auction facility 10. However, it will readily be appreciated that the present invention is not limited to use in such an exemplary facility.

[0050] The method 110 commences at block 112 with the definition, for example by a database designer, of a hierarchy of "actual" categories 100 being described by a respective category records that each specify a category identifier.

[0051] At block 114, the database designer then defines at least one hierarchy and multiple hierarchies, of "virtual" categories 102 within the category table 47. In one embodiment, the virtual categories are not intended to be presented to a user for selection to categorize a data item, but are linked, in the manner described above, to actual categories.

[0052] At block 116, in an actual_category field 86 for each "leaf" virtual category, the database designer includes a pointer (or link) in the form of a category identifier to a "actual" leaf category.

[0053] Figure 8 is a flow chart detailing a method 120, according to an exemplary embodiment of the present invention, of facilitating the location of a data item by navigation of a hierarchy of virtual categories.

[0054] The method 120 commences at block 122, with the presentation to a user of a list of top-level virtual categories. For example, the top-level categories may be the parent categories of the virtual categories 102 illustrated in Figure 6. The top-level categories may furthermore be presented in the form of a markup language document (e.g., a HTML document) that is generated by a page server 12 utilizing category information retrieved by the database engine server 22 from the database 23. Figure 9A provides an example of such a markup language document 138, which lists a number of top-level virtual categories 140.

[0055] At block 124, user selection of a virtual category is detected. For example, by performing a "point-and-click" operation utilizing a cursor control device, a user may select the "cars" category of the virtual categories 140 shown in **Figure 9A**, the selection being communicated to a CGI server 18 that in turn communicates the selection to an appropriate CGI script.

[0056] At block 126, a list of next-level virtual category is presented, based on the virtual category selected at block 124. **Figure 9B** illustrates an example of a markup language document that may be utilized to present an exemplary list 144 of such mixed-level categories. For example, a CGI script executing within a CGI server 18 and responsive to identification of a user-selected top-level category, may, via the database engine server 22, query the category table 47 to identify virtual categories that are child categories of the "cars" category. The results of this query are then communicated to a page server 12 that populates a template to generate the markup language document illustrated in **Figure 9B**. The list 144 of virtual categories shown in **Figure 9B** accordingly represents child categories of the "cars" virtual category.

[0057] At block 128, a user selection of a next-level virtual category is detected, in the same manner described above. For example, assuming user selection of a hypertext link 146 for the "Ford" category of the list 144 of categories shown in **Figure 9B**, this user selection may be communicated to a CGI server 18.

[0058] At block 130, a leaf category, or leaf categories, of the virtual category selected at block 128 may, in one embodiment, be identified so as to facilitate presentation of all data items associated with that leaf category or categories. For example, all leaf categories that depend from the virtual "Ford" category selected at block 128 may be identified. Such leaf categories may include the virtual "Taurus" category or the virtual "Model T" category discussed above with reference to **Figure 5**.

[0059] Where the category selected at block 128 itself comprises a leaf category, it will be appreciated that such a category itself be identified as the leaf category at block 130.

[0060] At block 132, a mapping, or linking, operation is performed so as to map the relevant virtual leaf categories identified at block 130 to actual leaf categories.

Specifically, as described above, this mapping operation may be performed utilizing a category identifier included within the actual_category field 86 of each relevant virtual category.

[0061] Having then identified one or more actual leaf categories corresponding to the virtual leaf categories, at block 134, data items categorized as being attributed to the identified real leaf categories are identified and presented in a user interface.

[0062] **Figure 9C** is an exemplary embodiment of a user interface, in the form of a markup language document, that may be utilized to present both the next level, or leaf, categories identified at block 130 and the data items identified at block 134 to a user. Specifically, the next level virtual categories are shown to be presented at 150, and the identified data items are shown to be presented at 152. It will be noted that the data items presented at 152 include data items within all of the virtual leaf categories listed at 150. Accordingly, the list of data items 152 may be extensive. For this reason, a user may wish to further navigate the hierarchy of virtual categories to further limit the list of data items 152 to a more manageable size.

[0063] Returning to **Figure 8**, at decision block 136, a determination is made as to whether a user selected a virtual leaf category at block 128. If the selected virtual category is not a leaf category, the method 120 loops back through blocks 126-134. For example, a user may select a hypertext link 154 for the virtual "Taurus" category, responsive to which the user will be presented, at block 134, with a list of data items identified as being within the actual "Taurus" category by performing a link between the virtual "Taurus" category and the actual "Taurus" category.

[0064] **Figure 9D** is an exemplary user interface, in the form of a markup language document, that illustrates the presenting of such a narrowed list of data items at 156. It will furthermore be noted that the user interface shown in **Figure 9D** does not provide a list of any child categories, as were shown at 150 in **Figure 9C**, as the virtual "Taurus" category is a leaf category.

[0065] As described above, in one embodiment, a user (e.g., a seller) utilizing the network-based auction facility 10 or an administrator classifying data items for presentation via a web site, may be presented with the option of only classifying data items within the context of a hierarchy of actual (and not virtual) categories.

[0066] **Figure 10A** shows an exemplary user interface, in the form of a markup language document, that facilitates classification by a user of a data item according to actual categories 100, such as those shown in **Figure 6**. The top-level (or parent) actual categories comprise vehicle types (e.g., a passenger vehicles, commercial trucks, boats, aircraft, etc.). Selection of a passenger vehicle type utilizing a drop-down menu 162 indicates both an actual parent category and an actual child category.

Alternatively, the user (i.e., seller) may be offering a further vehicle type for auction. User selection of the drop-down menu 164 allows the seller to specify such a further vehicle type.

[0067] **Figures 10B-10E** illustrates a further user interface 170 via which a user (i.e., a seller) may specify actual category information. In an exemplary embodiment, the information inputted by the user at block 172, as shown in **Figure 10B**, specifies an actual category. Specifically, for passenger vehicles, a leaf category is defined by a passenger vehicle make and model.

[0068] It should thus be noted that, in the exemplary embodiment, data items are classified according to a selected leaf category. Such leaf categories may be viewed as a category path selected within the context of a hierarchy of categories. For example, the full categorization of a data item may be viewed as the "passenger vehicle/Ford/Taurus" categorization.

Software

[0069] The methodologies described above may, it will be appreciated, be performed by software modules residing and executing on a wide variety of machines. In one embodiment, the mapping of the virtual leaf categories to actual leaf categories may be performed by a "listings produce" module or object that issues a series of SQL

statements against the database 23. The "listings produce" object may reside, for example, on a CGI server 18 or be part of the database engine server 22.

[0070] Figure 11 shows a diagrammatic representation of a machine in the exemplary form of a computer system 300 within which a set of instructions, for causing the machine to perform any one of the methodologies discussed above, may be executed. In alternative embodiments, the machine may comprise a network router, a network switch, a network bridge, Personal Digital Assistant (PDA), a cellular telephone, a web appliance or any machine capable of executing a sequence of instructions that specify actions to be taken by that machine.

[0071] The computer system 300 includes a processor 302, a main memory 304 and a static memory 306, which communicate with each other via a bus 308. The computer system 300 may further include a video display unit 310 (e.g., a liquid crystal display (LCD) or a cathode ray tube (CRT)). The computer system 300 also includes an alphanumeric input device 312 (e.g. a keyboard), a cursor control device 314 (e.g. a mouse), a disk drive unit 316, a signal generation device 320 (e.g. a speaker) and a network interface device 322

[0072] The disk drive unit 316 includes a machine-readable medium 324 on which is stored a set of instructions (i.e., software) 326 embodying any one, or all, of the methodologies described above. The software 326 is also shown to reside, completely or at least partially, within the main memory 304 and/or within the processor 302. The software 326 may further be transmitted or received via the network interface device 322. For the purposes of this specification, the term " machine-readable medium" shall be taken to include any medium that is capable of storing or encoding a sequence of instructions for execution by the machine and that cause the machine to perform any one of the methodologies of the present invention. The term "machine-readable medium" shall accordingly be taken to included, but not be limited to, solid-state memories, optical and magnetic disks, and carrier wave signals.

[0073] Thus, a method and system for categorizing items in both actual and virtual categories have been described. Although the present invention has been described

with reference to specific exemplary embodiments, it will be evident that various modifications and changes may be made to these embodiments without departing from the broader spirit and scope of the invention. Accordingly, the specification and drawings are to be regarded in an illustrative rather than a restrictive sense.

2001255423 08 Jun 2006

CLAIMS

1. A method of constructing a category structure within a database, the method including:
defining a first structure of categories to classify a data item, the first structure including at least a first category;
5 defining a second structure of categories to provide an alternative classification of the data item, the second structure including at least a second category;
defining the first structure of categories as a first hierarchy of categories and defining the second structure of categories as an alternative second hierarchy of categories,
0 wherein the second category is associated with the first category, the first category comprises a first category path defined in terms of the first structure of categories and the second category comprises a second category path defined in terms of the second structure of categories, the first category path including a first plurality of categories that are respectively associated with a first plurality of category identifiers and the second category path including a second plurality of categories that are respectively associated with a second plurality of category identifiers.
- 5 2 The method of claim 1 wherein the first category is a leaf category of the first hierarchy of categories.
3. The method of claim 1 wherein the second category is a leaf category of the second hierarchy of categories.
4. The method of claim 1 including defining the second category to point to the first category.
- 20 5. The method of claim 1 wherein the defining of the second structure includes defining the second hierarchy such that navigation of the second hierarchy to locate data items classified as being attributed to the second category locates data items classified as being attributed to the first category of the first hierarchy.
- 25 6. The method claim of 1 wherein the data item is user classifiable under the first structure of categories and is not user-classifiable under the second structure of categories.

2001255423 08 Jun 2006

7. The method of claim 1 wherein the data item is directly categorized as being within the first category of the first structure of categories and is indirectly categorized as being within the second category of the second structure of categories.
8. The method of claim 1 wherein the definition of the first and second structures of categories includes defining a category table including a category record for each category of the first and second structures of categories, each category record within the category table including a category identifier, wherein a category record that describes the second category includes a category identifier of a category record for the first category.
9. The method of claim 1 wherein the data item is a database record describing any one of a group of products and services of a transaction facilitated by a network-based transaction facility.
10. The method of claim 1 wherein the network-based transaction facility is a network-based auction facility.
11. The method of claim 1 including defining a third structure of categories to provide a further alternative classification of the data item, the third structure including at least a third category, wherein the third category is associated with the first category of the first structure of categories.
12. A method of classifying a data item within a database, the method including:
- identifying a first category, of a first hierarchy of categories, attributed to a data item; and
- automatically attributing a second category, of a second alternative hierarchy of categories, to the data item,
- wherein the first and second categories are defined by respective category paths of the first and second hierarchies of categories, the first category path including a first plurality of categories that are respectively associated with a first plurality of category identifiers and the second category path including a second plurality of categories that are respectively associated with a second plurality of category identifiers.
13. The method of claim 12 wherein the first and second categories are associated within a description of categories within the database.

2001255423 08 Jun 2006

14. The method of claim 12 wherein the first category is attributed to the data item by a user during a user classification operation and the second category is dynamically attributed to the data item during a user navigation operation of the second hierarchy of categories, wherein the dynamic attributing of the second category is performed by identification of an association between the first and second categories.

5 15. The method of claim 12 wherein the first categories is directly recorded within the database as being attributed to the data item and the second category is recorded as being linked to the first category within the database.

16. The method of claim 12 wherein the first and second categories are each leaf categories of the respective first and second hierarchies of categories.

0 17. A method of facilitating location of a data item within a database, the method including:

facilitating user-navigation of a first category structure to select a first category;

identifying a second category of a second category structure as being linked to the first category of the first category structure; and

15 identifying data items of the second category responsive to the selection of the first category of the first category structure,

wherein the first and second category structures comprise respective first and second hierarchies of categories, and

20 wherein the first and second categories are defined by respective category paths of the first and second hierarchies of categories, the first category path including a first plurality of categories that are respectively associated with a first plurality of category identifiers and the second category path including a second plurality of categories that are respectively associated with a second plurality of category identifiers, wherein the first category structure includes a first hierarchy of categories and the second category structure includes a second alternative hierarchy of categories.

18. The method of claim 17 wherein the facilitating of the user navigation comprises presenting at 25 least one user interface to display navigation information according to the first hierarchy of categories.

19. The method of claim 18 wherein the presenting of the at least one user interface comprises generating at least one markup language document.

2001255423 08 Jun 2006

20. The method of claim 19 including providing, with the context of the markup language document, any one of a group of navigation aids including a drop-down menu, a selection of check boxes, a selection of radio buttons, an embedded Java application and an embedded ActiveX control.

5 21. The method of claim 17 wherein the identification of the second category comprises accessing a category table including a first record describing the first category, wherein the first record includes a pointer to a second record within the category table describing the second category.

22. The method of claim 17 wherein the identifying of the data items comprises accessing an items table to identify at least a first record identifying the second category.

0 23. The method of claim 17 wherein the first and second categories comprise respective leaf categories of the first and second hierarchies of categories.

24. The method of claim 17 including communicating the identified data items within a markup language document transmitted over a network.

25. A machine-readable medium storing a sequence of instructions that, when executed by a machine, cause the machine to:

5 identify a first category, of a first hierarchy of categories, attributed to a data item; and

automatically attribute a second category, of a second hierarchy of categories, to the data item,

20 wherein the first and second categories are defined by respective category paths of the first and second hierarchies of categories, the first category path including a first plurality of categories that are respectively associated with a first plurality of category identifiers and the second category path including a second plurality of categories that are respectively associated with a second plurality of category identifiers.

26. A machine-readable medium for storing a sequence of instructions that, when executed by a machine, cause the machine to:

facilitate user-navigation of the first category structure to select a first category;

25 identify a second category of a second category structure s being linked to the first category of the first category structure; and

identify data items of the second category responsive to the selection of the first category of the first category structure,

wherein the first and second category structures comprise respective first and second hierarchies of categories, and

wherein the first and second categories are defined by respective category paths of the first and second hierarchies of categories, the first category path including a first plurality of categories that are respectively associated with a first plurality of category identifiers and the second category path including a second plurality of categories that are respectively associated with a second plurality of category identifiers, wherein the first category structure includes a first hierarchy of categories and the second category structure includes a second alternative hierarchy of categories.

27. A method of constructing a category structure within a database, substantially as described herein with reference to any one of the figures.

28. A method of classifying a data item within a database, substantially as described herein with reference to any one of the figures.

5 29 A method of facilitating location of a data item within a database, substantially as described herein with reference to any one of the figures

08 Jun 2006

2001255423

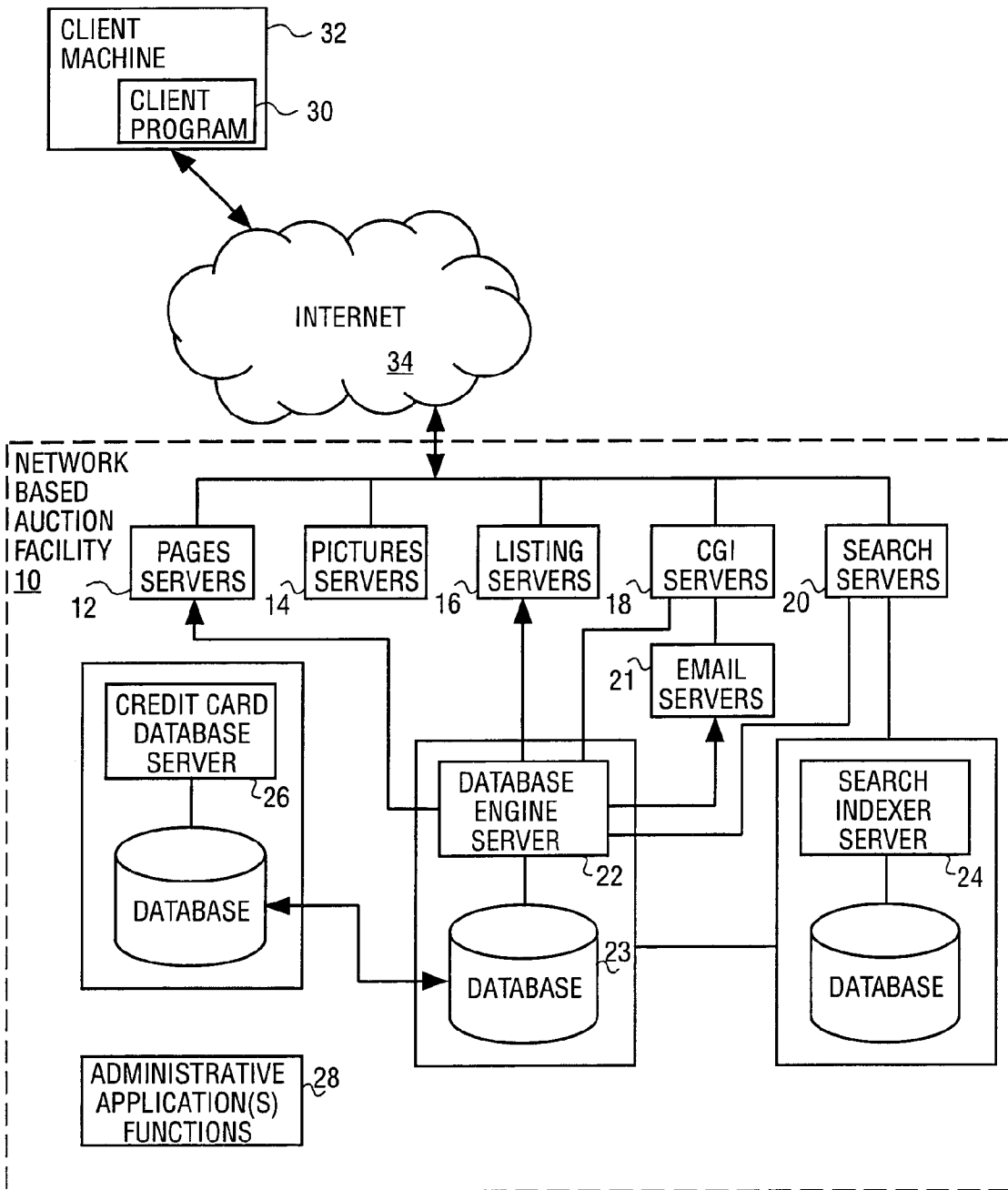

FIG. 1

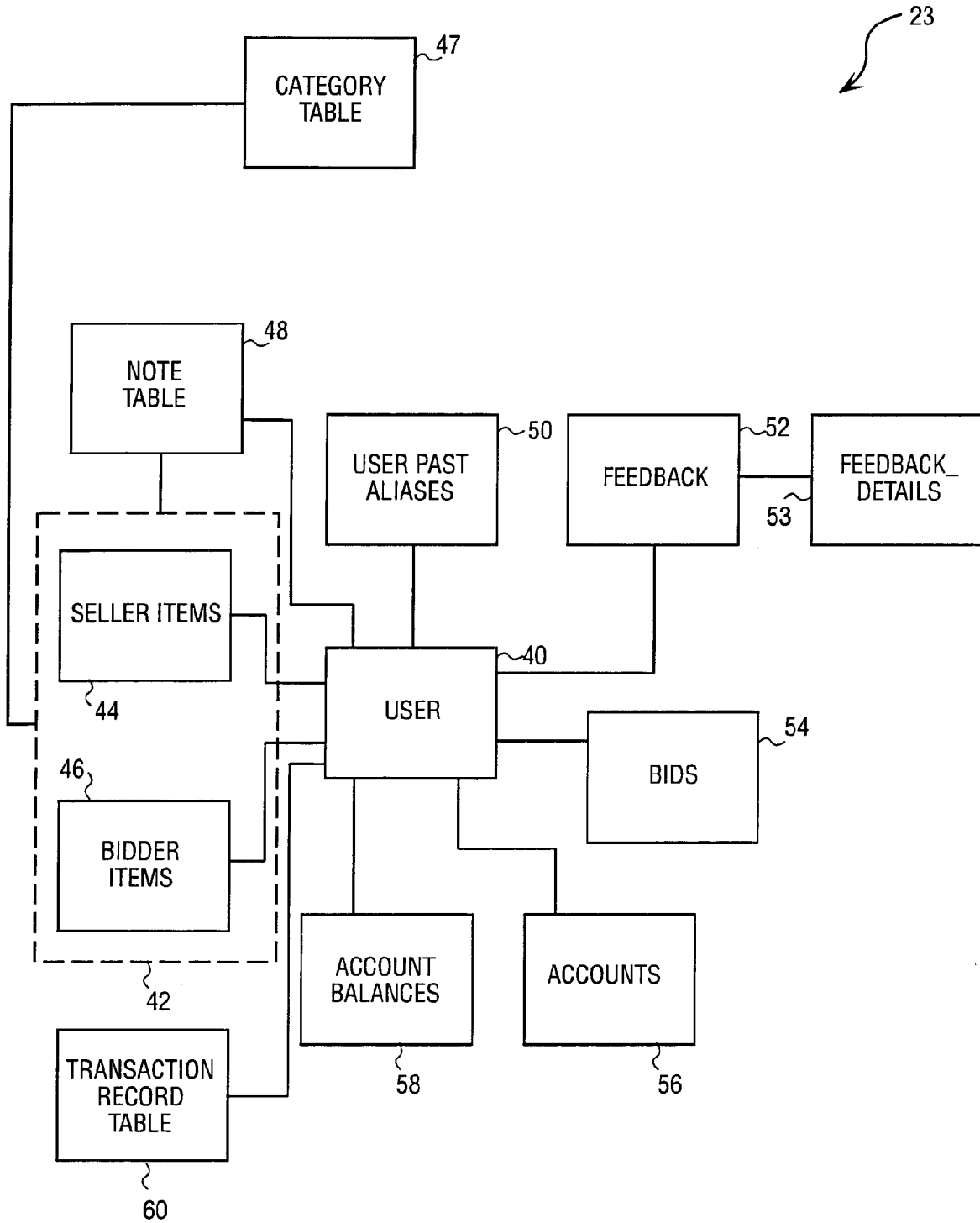

FIG. 2

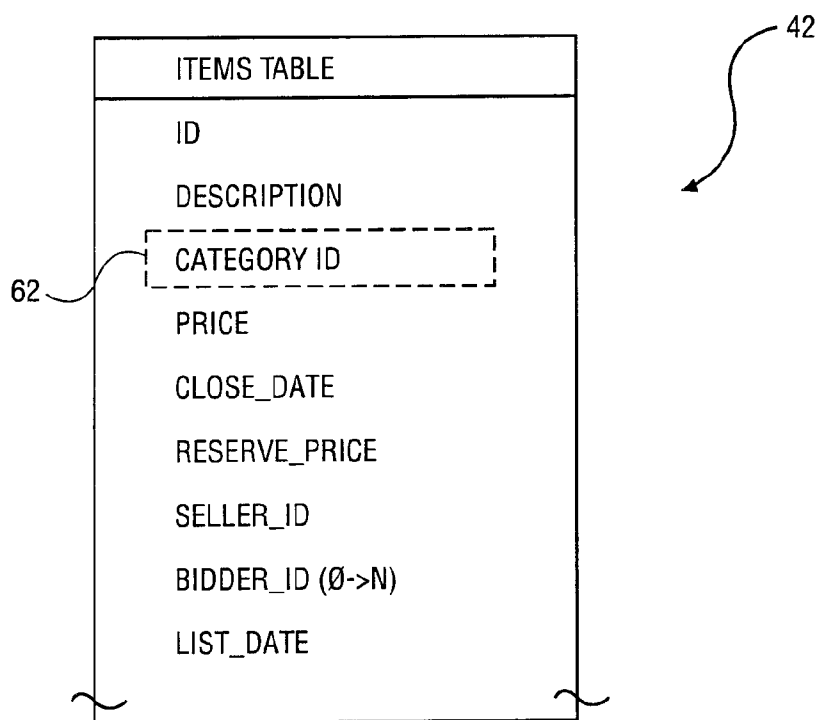

FIG. 3

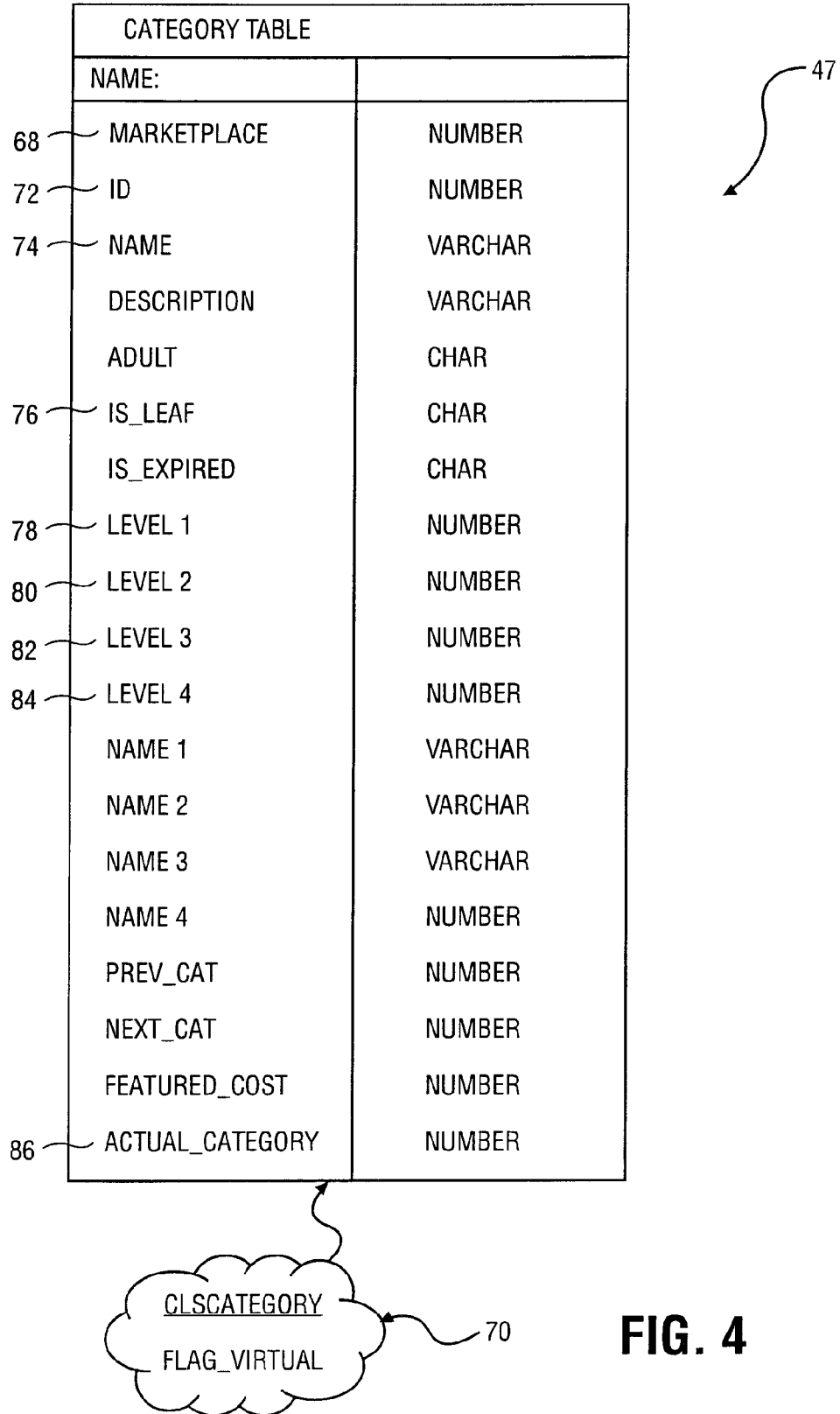

FIG. 4

CATEGORY TABLE							
NAME ⁷⁴	ID ⁷²	ACTUAL_CATEGORY ⁸⁶	LEVEL1 ⁷⁸	LEVEL2 ⁸⁰	LEVEL3 ⁸²	IS_LEAF ⁷⁶	
PASSENGER	50	∅				N	
FORD	2000	∅	50			N	
TAURUS	8000	∅	2000	50		Y	
MODEL T	8500	∅	2000	50		Y	
CARS	51	∅				N	
FORD	2001	∅	51			N	
TAURUS	8001	8000	2001	51		N	
VINTAGE CARS	52	∅				N	
FORD	2002	∅	52			N	
MODEL T	8502	8500	2002	52		N	

90
ACTUAL
CATEGORY

92
VIRTUAL
CATEGORY

94
VIRTUAL
CATEGORY

47

FIG. 5

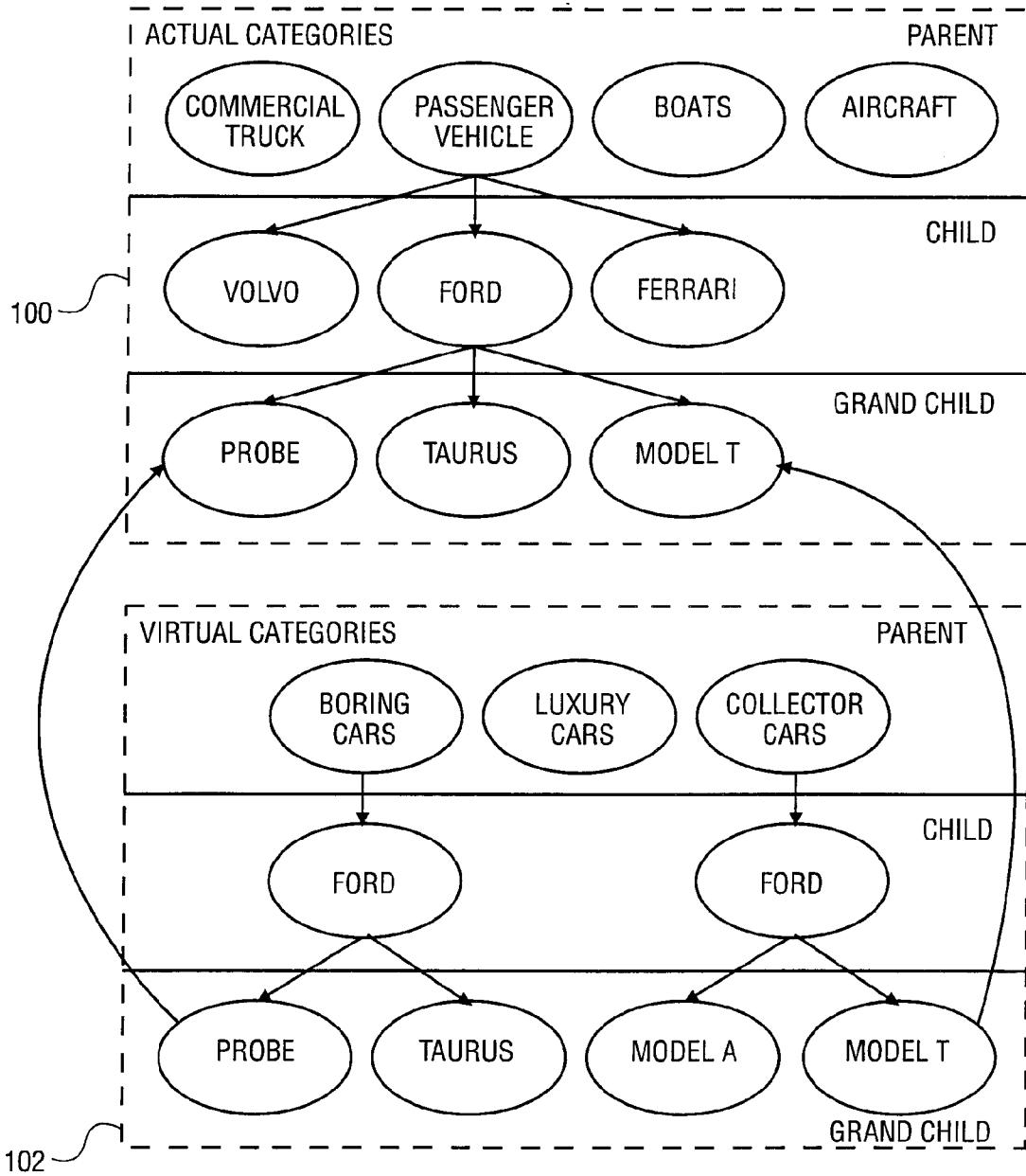

FIG. 6

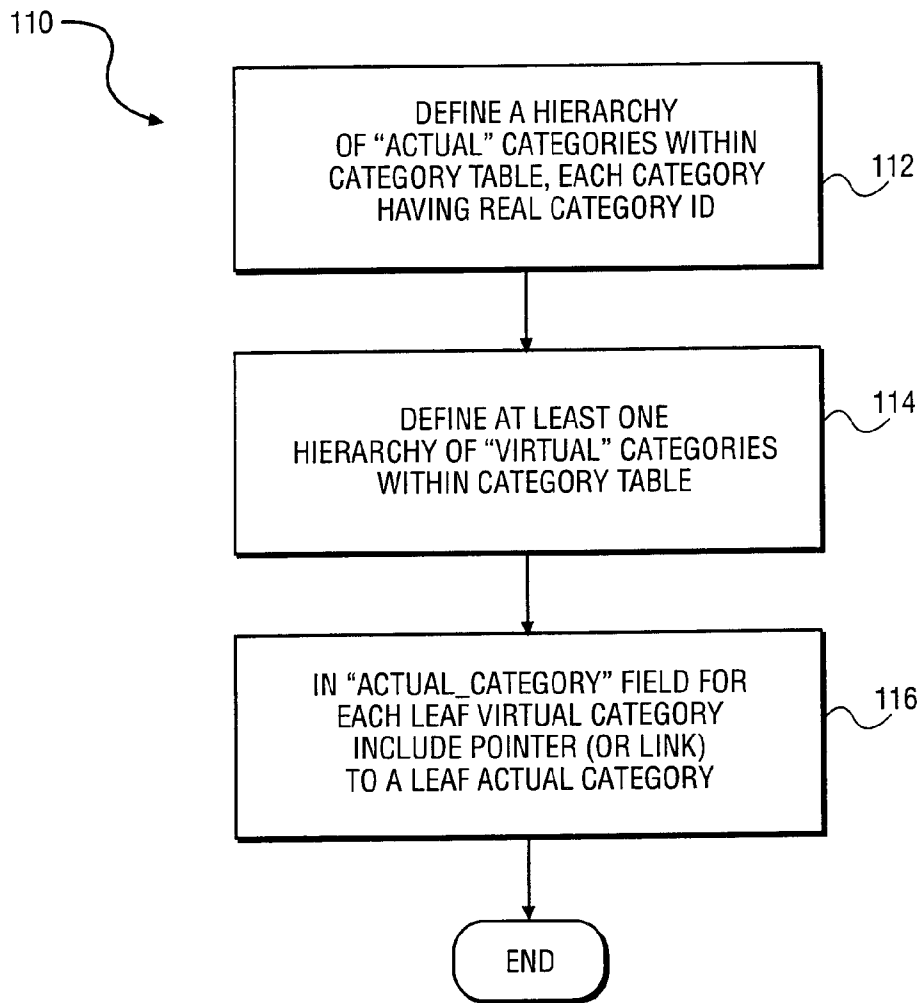

FIG. 7

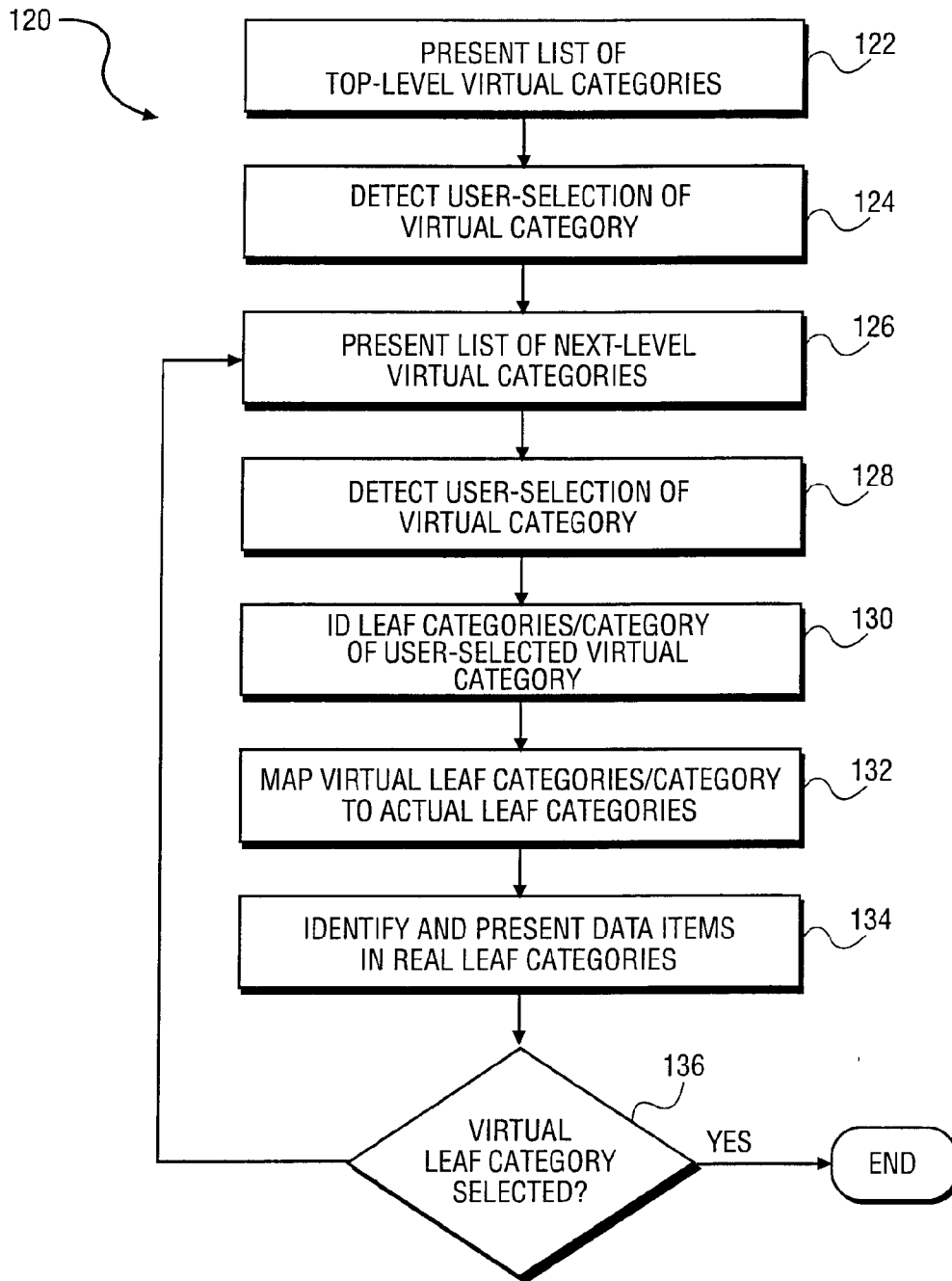
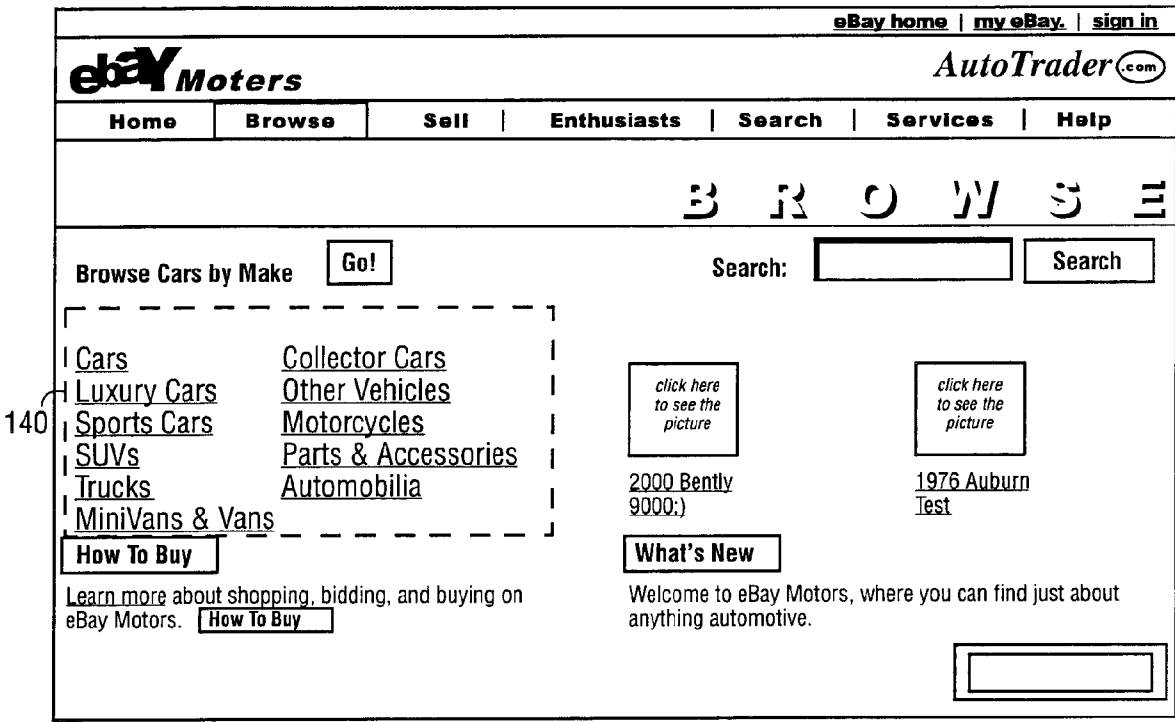

FIG. 8



138

FIG. 9A

10/18

eBay home | my eBay | sign in

eBay Motors **AutoTrader** .com

Home | **Browse** | **Sell** | **Enthusiasts** | **Search** | **Services** | **Help**

C A R S

Cars | **Luxury Cars** | **Sports Cars** | **SUV** | **Trucks** | **Mini/Vans** | **Motorcycles** | **Collector** | **Other Vehicles** | **Parts** | **Automobilia**

Search: Search titles and description [More Options...](#)

Home > Browse > **Cars**

[click here to see the picture](#)
2000 GTO

[click here to see the picture](#)
2000 All Models

[click here to see the picture](#)
2000 Royal

[click here to see the picture](#)
2000 928

Services
 -Financing
 -Inspections
 -Collector Car Insurance
 -Vehicle Shipping
 -Escrow

How To Buy
 Learn more about shopping, bidding, and buying on eBay Motors. [How To Buy](#)

What's New
 Welcome to eBay Motors, where you can find just about anything automotive.

Browse By Make

Acura (0)	Alfa Romeo (0)	AMC (0)
Aston Martin (0)	Auburn (0)	Audi (0)
Austin (0)	Austin Healey (0)	Avanti (0)
Bentley (0)	BMW (0)	Bugatti (0)
Buick (0)	Cadillac (0)	Chevrolet (0)
Chrysler (0)	Citroen (0)	Cord (0)
Datson (0)	DeSoto (0)	Dodge (0)
Eagle (0)	Edsel (0)	Ferrari (0)
Fiat (0)	Ford (0) ~ 146	Geo (0)
Honda (0)	Hyundai (0)	Infiniti (0)
Isuzu (0)	Jaguar (0)	Kia (0)
Lamborghini (0)	Lancia (0)	Lexus (0)
Lincoln (0)	Lotus (0)	Maserati (0)
Mazda (0)	Mercedes-Benz (0)	Mercury (0)
MG (0)	Mitsubishi (0)	Nissan (0)
Oldsmobile (0)	Opel (0)	Packard (0)
Peugot (0)	Plymouth (0)	

Related Links
 Enthusiast pages: [Ford Mustang](#) * [Corvette](#) * [Harley Davidson](#) * [Muscle Cars](#)
 Related categories on eBay Motors: [Automobilia](#) * [Parts & Accessories](#) * [Other Vehicles](#)
 Related categories on eBay: [Diecast Toys](#) * [Vintage Toy Vehicles](#) * [Auto Advertising](#)

FIG. 9B

11/18

eBay home | my eBay | sign in

eBay Motors **AutoTrader.com**

Home | **Browse** | **Sell** | **Enthusiasts** | **Search** | **Services** | **Help**

Search: Search titles and description [More Options...](#)

Home : Browse : Cars : Ford

Featured Ford



[click here to see the picture](#)

[Ford : Other Models](#)

[click here to see the picture](#)

[Ford : Probe](#)

[click here to see the picture](#)

[Ford : Thunderbird](#)

[click here to see the picture](#)

[Ford : Escort](#)

- Financing
- Inspections
- Collector Car Insurance
- Vehicle Shipping
- Escrow

Browse 150

Aspire (9)	Falcon (9)	Probe (9)
Crown Victoria (9)	Galaxie (9)	Taurus (9) 1
Escort (9)	Model A (9)	Tempo (9)
Fairlane (9)	Model T (9)	Thunderbird (9)
Fairmont (9)	Mustang (13)	Other Models (9)

154

Items in Ford View: [Current](#) | [New Today](#) | [Ending Today](#) | [Going, Going, Gone](#)

Show items located in:

Picture	Make - Model	Mileage	Year	Price	Bids	Ends PDT
click here to see the picture	Ford : Probe Automated Test 4/07/00	123	2000	\$1.00	-	Apr 17 20:36
click here to see the picture	Ford : Taurus Automated Test 4/07/00	123	2000	\$1.00	-	Apr 17 20:37
click here to see the picture	Ford : Tempo Automated Test 4/07/00	123	2000	\$1.00	-	Apr 17 20:37
click here to see the picture	Ford : Thunderbird Automated Test 4/07/00	123	2000	\$1.00	-	Apr 17 20:37
click here to see the picture	Ford : Other Models Automated Test 4/07/00	123	2000	\$1.00	-	Apr 17 20:37

152

FIG. 9C

[eBay home](#) | [my eBay](#) | [sign in](#)

eBay Motors **AutoTrader** .com

[Home](#) | [Browse](#) | [Sell](#) | [Enthusiasts](#) | [Search](#) | [Services](#) | [Help](#)

Search: Search titles and description [More Options...](#)

[Home](#) : [Browse](#) : [Cars](#) : [Ford](#) : [Taurus](#)

Featured Taurus

click here to see the picture

[Ford : Taurus](#)

click here to see the picture

[Ford : Taurus](#)

click here to see the picture

[Ford : Taurus](#)

click here to see the picture

[Ford : Taurus](#)

- Financing
- Inspections
- Collector Car Insurance
- Vehicle Shipping
- Escrow





Browse

Items in Taurus 156 View: [Current](#) | [New Today](#) | [Ending Today](#) | [Going, Going, Gone](#)

Show items located in:

Picture	Make - Model	Mileage	Year	Price	Bids	Ends PDT
<i>click here to see the picture</i>	Ford : Taurus sub-title	123	2000	\$1.00	-	Apr-17 19:00
<i>click here to see the picture</i>	Ford : Taurus sub-title	123	2000	\$1.00	-	Apr-17 19:58
<i>click here to see the picture</i>	Ford : Taurus sub-title	123	2000	\$1.00	-	Apr-17 20:16
<i>click here to see the picture</i>	Ford : Taurus sub-title	123	2000	\$1.00	-	Apr-17 20:34
<i>click here to see the picture</i>	Ford : Taurus sub-title	123	2000	\$1.00	-	Apr-17 20:51
<i>click here to see the picture</i>	Ford : Taurus Automated Test 4/07/00	123	2000	\$1.00	-	Apr-17 20:37

FIG. 9D

eBay home my eBay sign in						
eBay Motors			AutoTrader <small>.com</small>			
   						
Home	Browse	Sell	Enthusiasts	Search	Services	Help

Visit [How to Sell](#) in the [Help](#) section for selling tips.

Inspection makes your car more valuable to bidders and can improve your results. Click on the Inspection button for details.

[How to sell](#)

[Inspection](#)

Selling a Passenger Vehicle?
(Cars, Pickups, SUV's, Minivans...)

162

Select Make: ▾

[Continue Listing >](#)

Selling a Motorcycle?

Select Make: ▾

[Continue Listing >](#)

Selling Other Vehicles?
(Commercial Trucks, Boats, Aircraft, Scooters...)

Select Type: ▾

164

[Continue Listing >](#)

Selling Parts or Accessories?
(Includes Apparel, Tools, Manuals...)

Select Type: ▾

For Parts or Accessories

Select Related Make: ▾

[Continue Listing >](#)

Selling Automobilia?
(License Plates, Pins, Patches...)

Select Type: ▾

[Continue Listing >](#)

[Home](#) [Browse](#) [Sell](#) [Enthusiasts](#) [Search](#) [Services](#) [Help](#)

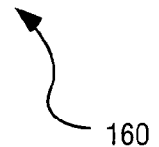

160

FIG. 10A

eBay home my eBay sign in						
eBay Motors			AutoTrader <small>com</small>			
Home	Browse	Sell	Enthusiasts	Search	Services	Help

We recommend you check out [How to Sell - Vehicles](#) before you begin.

170



You are selling a **Passenger Vehicle**. If this is not correct, see [Seller's Overview](#)

Item Information

User ID & Password

Don't have a password?
Register now, its free!

User ID or Email address

Password (forgotten it?)

All this information will be included in your item listing. Be sure to include other details in your item description.

Make	Acura change make
Model	CL <input type="text"/> if "All/Other Models" please specify <input type="text"/> (optional)

172



Year

Sub Model

ex. DX, SI, Turbo, GT optional

VIN

Vehicle Identification Number. [What is a VIN?](#)

Required for Saturn inspections. Otherwise optional, but strongly recommended due to high importance to buyers.

Type of Vehicle Title

Clear (most titles) Salvage Other (specify in Description)

[How do I find this out?](#)

Mileage

miles (If in kilometers please convert to miles)
ex. 45,000

Color

Exterior Interior

Number of Cylinders

[Where do I find this?](#)

Transmission

Number of Doors

Condition

[How do I find this out?](#)

Used New

Vehicle Inspection

None Saturn Other (Specify in description)

FIG. 10B

How can I get my vehicle inspected?

170

Options
How do I find this out?

- Air conditioning
- CD Player
- Convertible
- 4 Wheel Drive
- Cruise Control
- Leather Seats
- Sunroof
- Cassette

Airbags

- Driver Airbag
- Passenger Airbag
- Side Airbags

Power Options

- Anti Lock Brakes
- Power Locks
- Power Seats
- Power Windows

Is There an Existing Warranty?
How do I find this out?

- No
- Yes (specify Year/Mileage warranty expiration in Item Description)

Items Subtitle

Title Tips 45 characters max
Include vehicle highlights here like no reserve, low miles, great condition.
Make, model, year are automatically included in the listings.
Do not include HTML tags, asterisks, or quotes, as they interfere with Search.

Item Description

Enter additional description
We recommend reading our Description Tips

You can use basic HTML tags to spruce up your listing

You can add links to additional photos, but enter your primary photo in the Picture URL below.

Note: If you want more than one photo for your item, insert its URL (web address) in the Description section in the following format:

Gallery / Picture

URL Please use only .jpg, bmp or tif files. gif files will not appear.

optional For best results, use an image that is at least 250 pixels wide.

Why we recommend using a photo This picture will appear in listings as a gallery thumbnail and in the item description. This options is free!

It's easy! Learn the basics in the [tutorial](#), and enter your URL (web address) here.

Item Location

Enter Item location and region if item is located in the United States

City, State (e.g., San Jose, CA)

Learn more about regional setting

"Go Local" Regions (US items only)

Country

Make your item stand out and get more bids! Try these winning options.

FIG. 10C

eBay Featured \$99.95 charge
[Details](#)

Gallery Featured \$99.95 charge
[Details](#)

Category Featured \$14.95 charge
[Details](#)

Boldface Title \$4.00 charge
[Details](#)

Listing Icon \$2.00 charge
[Details](#) No Icon [US Flag] [Checkered Flag] [4X4] [Gift]
 [Graduation]

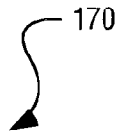

Auction Information

Payment Methods
Choose all that you will accept. Enter specific payment information
[Item Description](#)

Money Order/Cashiers Check Personal Check Visa/MasterCard
 COD (collect on delivery) Discover American Express
 See Item Description Other

Escrow
[learn more](#)

I will accept escrow, buyer pays (recommended)
 I will pay for escrow
 I will not accept escrow (if selected, the Escrow section will not appear on the item listing)

Where Will You Ship Your Vehicle?
[See tips on shipping](#)

Will ship to United States only
 Will ship internationally (worldwide)
 Will ship to United States and the following regions: (Check all that apply)

- Canada
- Europe
- Australasia
- Asia
- South America
- Africa
- Mexico and Central America
- Middle East
- Caribbean

Will not ship

Who Pays For Shipping?

Seller Pays Shipping Buyer Pays Fixed Amount.
 Buyer Pays Actual Shipping Cost See Item Description

Starting Bid
[See tips on setting starting bid amounts](#) (e.g., 2.00 - Please do not include commas or currency symbols, such as \$.)

FIG. 10D

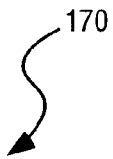
170

Auction Duration days

Reserve Price
optional
[See tips on setting Reserve Prices.](#) (e.g., 15.00 - Please do not include commas or currency symbols, such as \$.)
Careful! Reserve Auction fees will apply if you item does not sell. [Learn more](#)

Private Auction? Yes, this is a private auction.
optional
[Private Auction Details](#) Don't use this unless you have a specific reason.

Press "Continue" to preview the item and review fees. You will not incur any fees until you accept the terms disclosed in the next screen.

Continue	Clear form and start over
----------	---------------------------

Note: If the Back button on your browser erases your information on this form, [learn how to fix this](#).

[Home](#) [Browse](#) [Sell](#) [Enthusiasts](#) [Search](#) [Services](#) [Help](#)

FIG. 10E

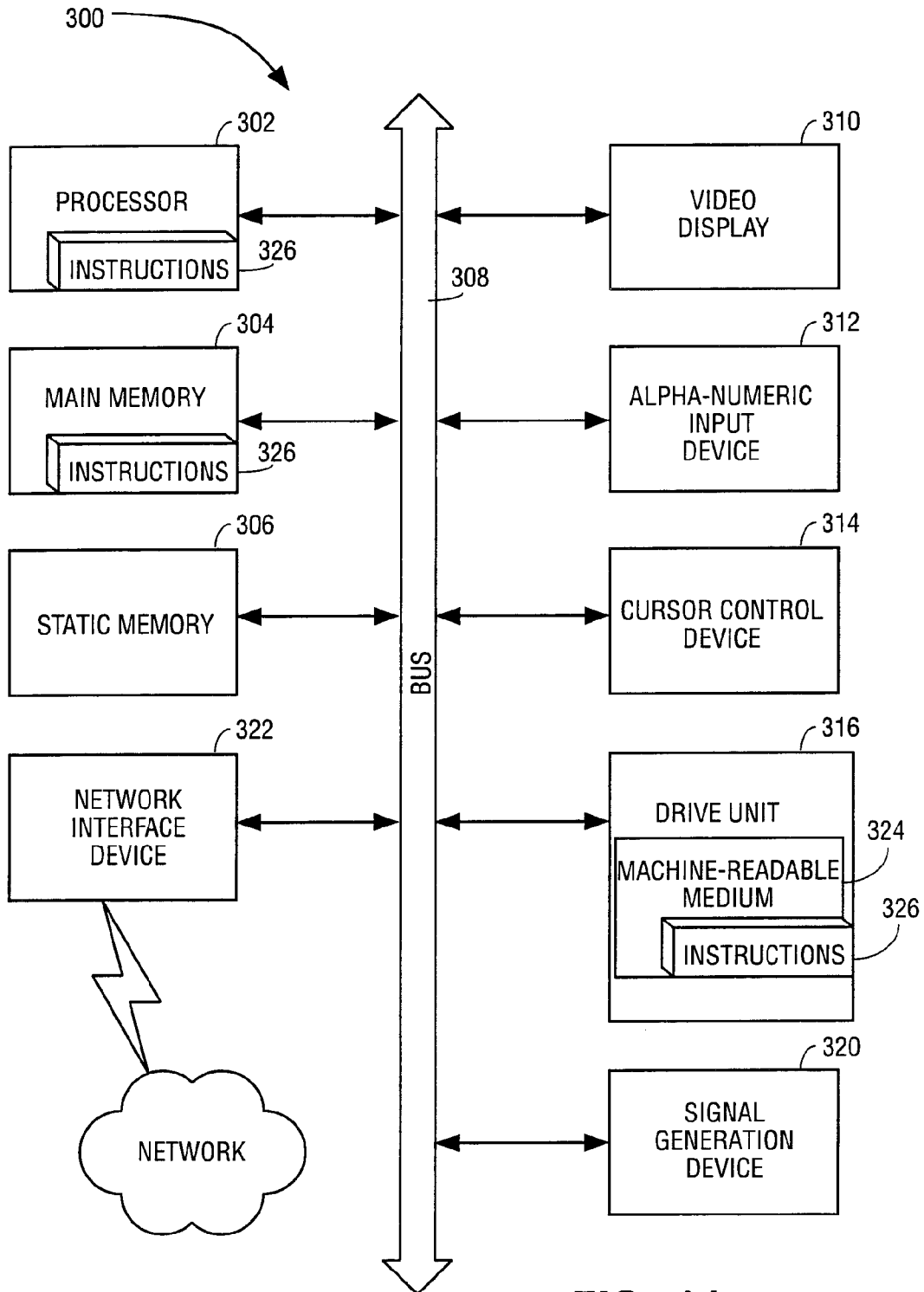

FIG. 11