



US00D980187S

(12) **United States Design Patent**
Su

(10) **Patent No.:** **US D980,187 S**

(45) **Date of Patent:** **** Mar. 7, 2023**

(54) **EARPHONE**
(71) Applicant: **Shenzhen Arington Technology Co., Ltd.**, Shenzhen (CN)

D695,264 S * 12/2013 Chee D14/205
D707,199 S * 6/2014 Cepress H04R 1/10
D14/205

(72) Inventor: **Xiaoyong Su**, Hanzhong (CN)

D713,375 S 9/2014 Dedinas
(Continued)

(73) Assignee: **Shenzhen Arington Technology Co., Ltd.**, Shenzhen (CN)

FOREIGN PATENT DOCUMENTS

CN 307048352 * 1/2022
CN 307266128 * 4/2022

(**) Term: **15 Years**

OTHER PUBLICATIONS

(21) Appl. No.: **29/812,774**

10 best bone conducting headphones, headphonesty website article 2022, site visited Jul. 15, 2022, <https://www.headphonesty.com/2019/04/best-bone-conduction-headphones/>*

(22) Filed: **Oct. 25, 2021**

(51) **LOC (14) Cl.** **14-01**

Primary Examiner — John R Yeh

(52) **U.S. Cl.** **D14/205**
USPC

(74) *Attorney, Agent, or Firm* — Georgi Korobanov

(58) **Field of Classification Search**
USPC D14/204–206, 223; D13/108
CPC .. H04R 1/1083; H04R 1/1041; H04R 1/1016;
H04R 5/0335; H04R 1/1066; H02J
7/0044

(57) **CLAIM**

The ornamental design for a earphone, as shown and described.

See application file for complete search history.

DESCRIPTION

(56) **References Cited**

FIG. 1 is a perspective view of a earphone showing my new design;
FIG. 2 is another perspective view thereof;
FIG. 3 is a front elevational view;
FIG. 4 is a rear elevational view thereof;
FIG. 5 is a left side view thereof;
FIG. 6 is a right side view thereof;
FIG. 7 is a top plan view thereof;
FIG. 8 is a bottom plan view thereof;
FIG. 9 is an enlarged view taken from the indication in FIG. 1; and,
FIG. 10 is an enlarged view taken from the indication in FIG. 2.

U.S. PATENT DOCUMENTS

5,457,751 A * 10/1995 Such H04R 1/1058
381/381
D404,035 S * 1/1999 Delazzer D14/206
D426,880 S * 6/2000 Leight D24/106
6,154,539 A * 11/2000 Pitel H04M 1/05
379/430
D468,723 S 1/2003 Pham et al.
D488,460 S 4/2004 Alwicker
D558,735 S 1/2008 Carr
D565,026 S * 3/2008 Brennwald D14/205
D617,308 S * 6/2010 Nousiainen D14/205
D669,881 S * 10/2012 Clements D14/205
D671,915 S * 12/2012 Birger D14/206
D678,856 S * 3/2013 Feng D14/205
D691,105 S * 10/2013 Ito D14/205

The evenly dashed broken lines in the drawings depict portions of earphone that form no part of the claimed design. The dot-dash lines indicate the enlarged view areas and form no part of the claimed design.

1 Claim, 10 Drawing Sheets

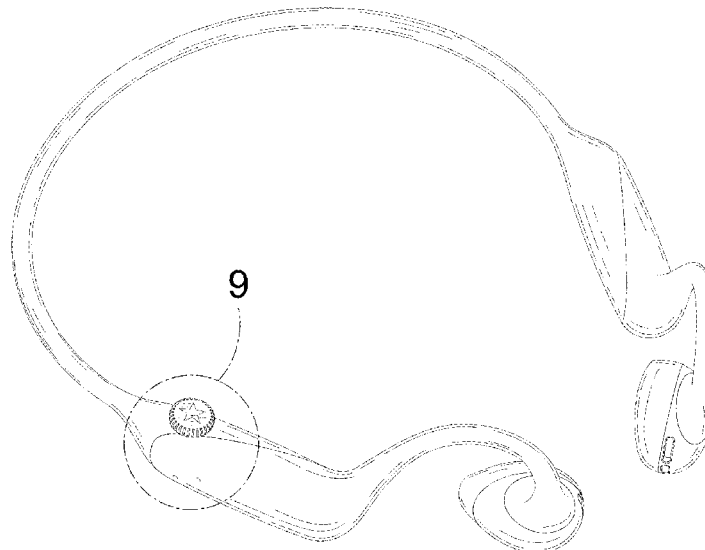

(56)

References Cited

U.S. PATENT DOCUMENTS

D717,765 S * 11/2014 Rausch D14/205
D740,785 S 10/2015 Chen
D769,220 S 10/2016 Burgett
D790,501 S * 6/2017 Wang D14/205
D791,100 S * 7/2017 Chen D14/205
D810,719 S 2/2018 Nagamine
D812,035 S 3/2018 Petersen
D829,190 S * 9/2018 Bullen D14/205
D837,184 S 1/2019 Zhu
D842,837 S * 3/2019 Li D14/205
D869,435 S * 12/2019 Sanhua D14/205
D875,710 S * 2/2020 Bailey D14/205
D926,731 S 8/2021 Deng
D953,287 S * 5/2022 Wu D14/205
2009/0185699 A1 * 7/2009 Kim H04R 1/1066
381/151
2012/0140974 A1 * 6/2012 Danielson H04R 1/1066
381/379
2014/0185837 A1 * 7/2014 Kunimoto H04R 1/1075
381/151
2019/0029529 A1 * 1/2019 Haartsen A61B 5/721
2020/0084546 A1 * 3/2020 Mainini H04R 1/1016

* cited by examiner

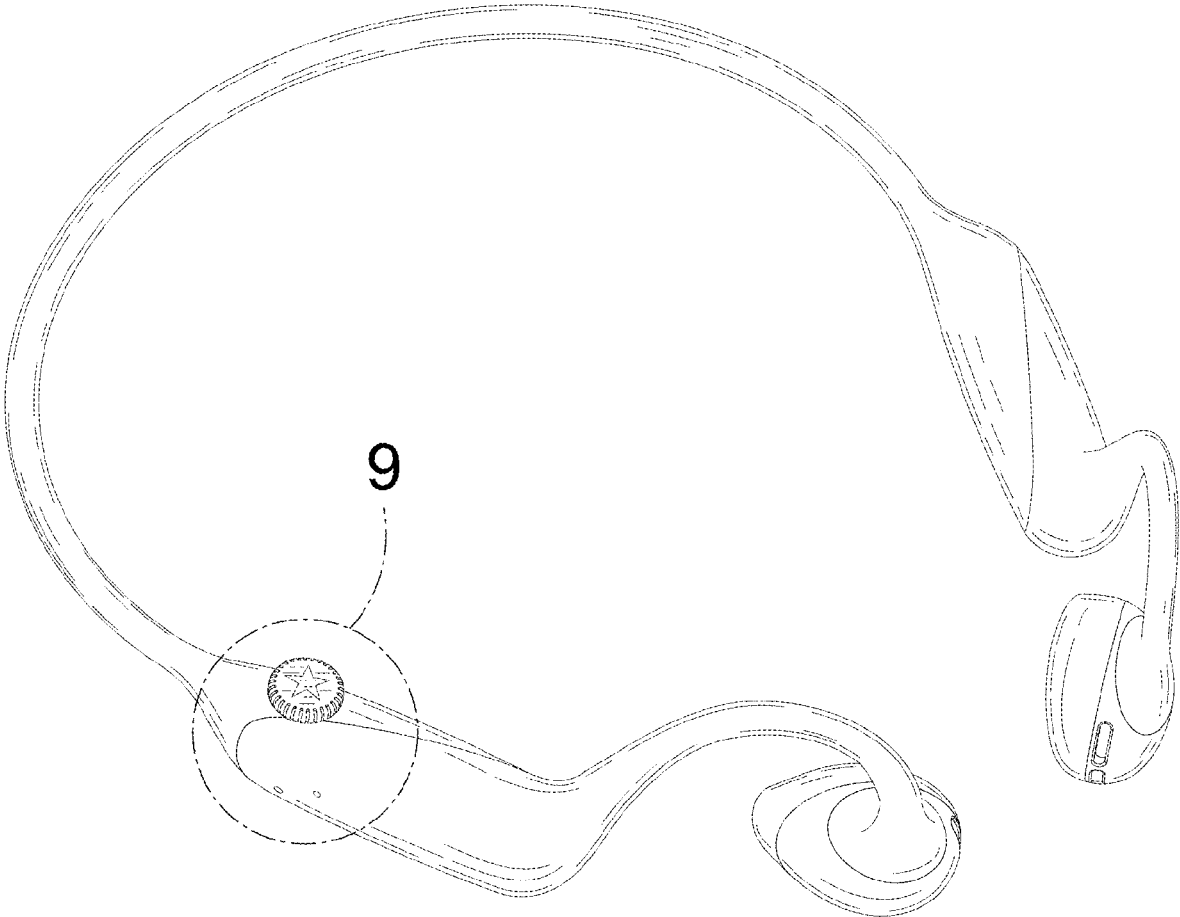

FIG. 1

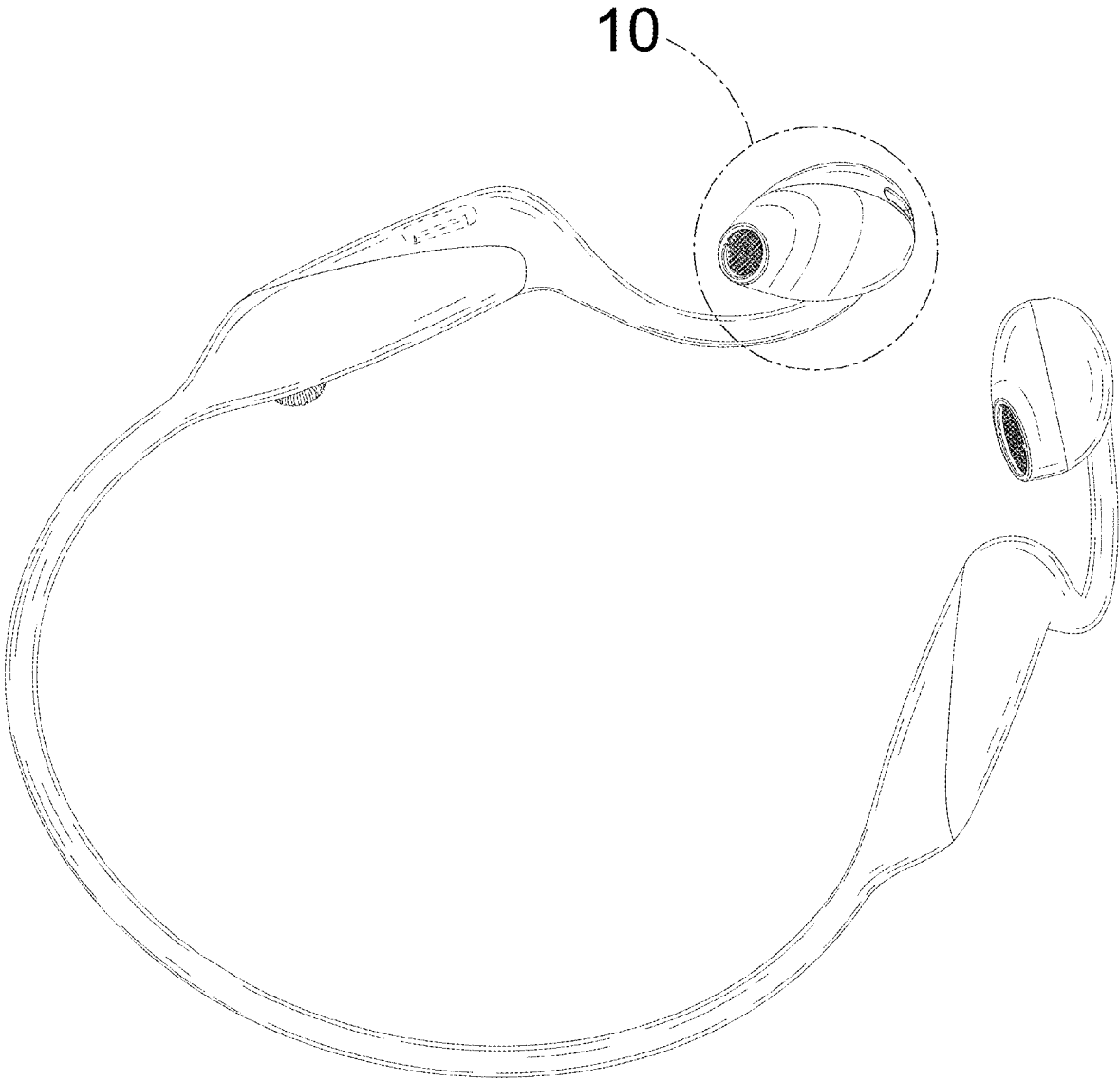

FIG. 2

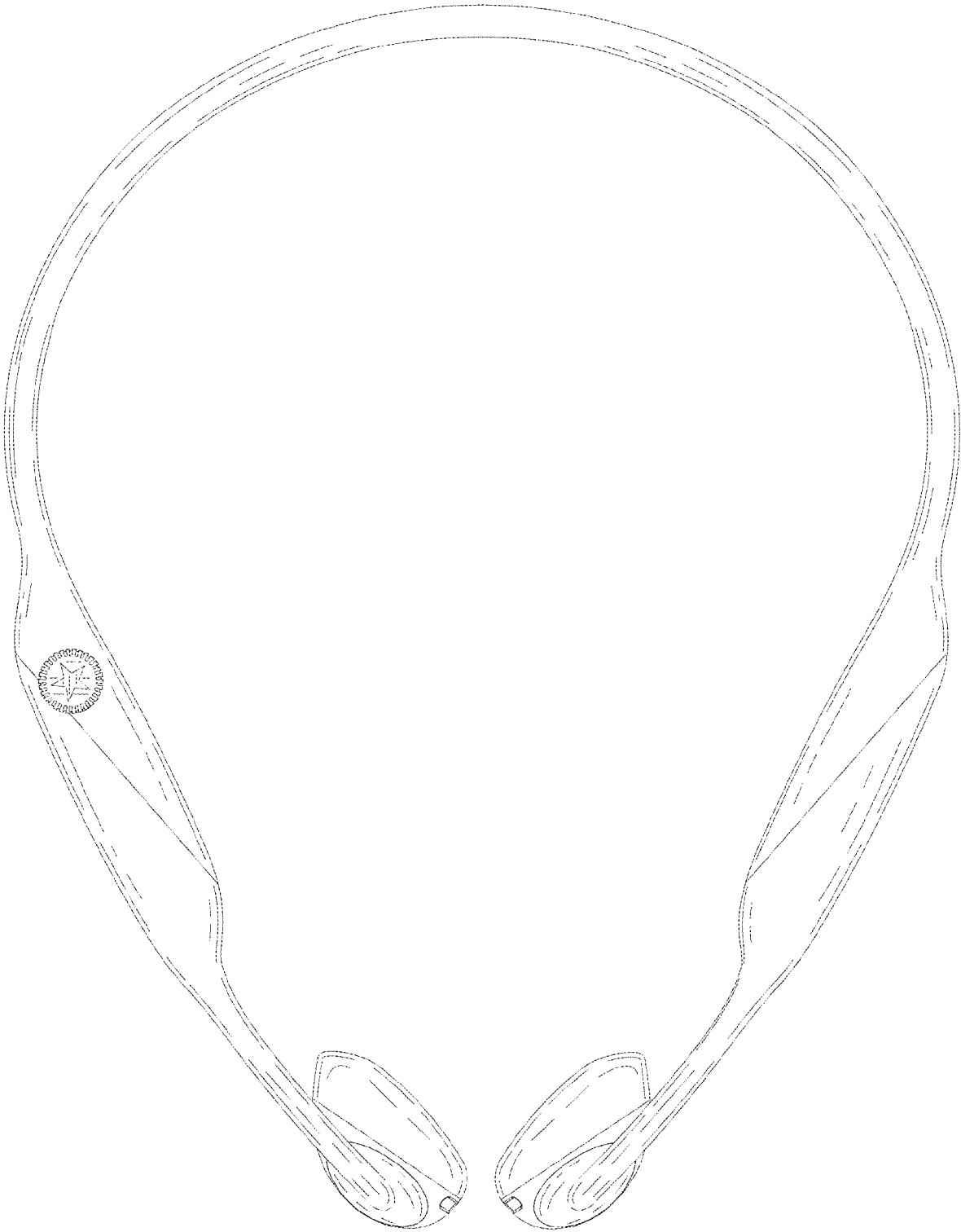

FIG. 3

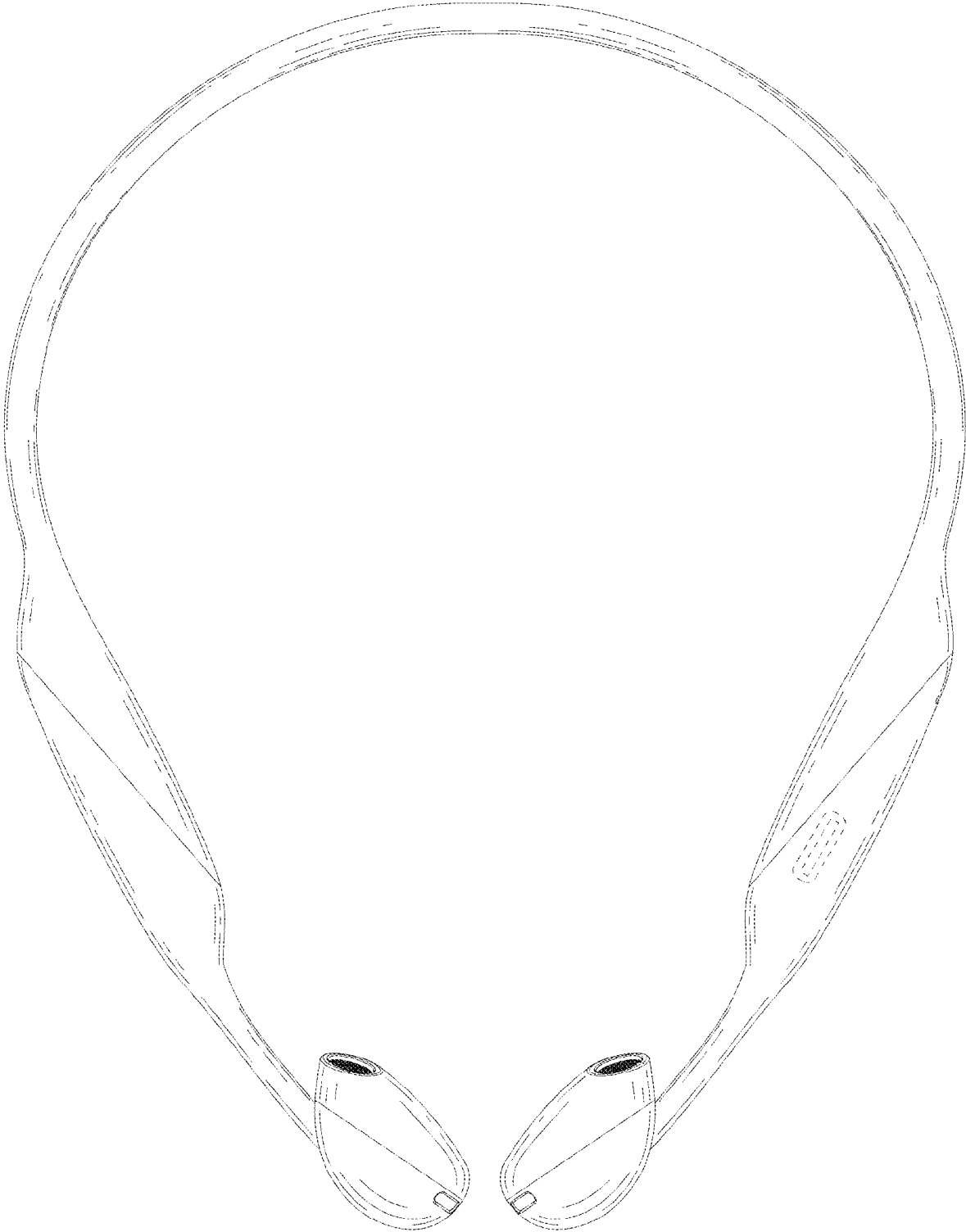

FIG. 4

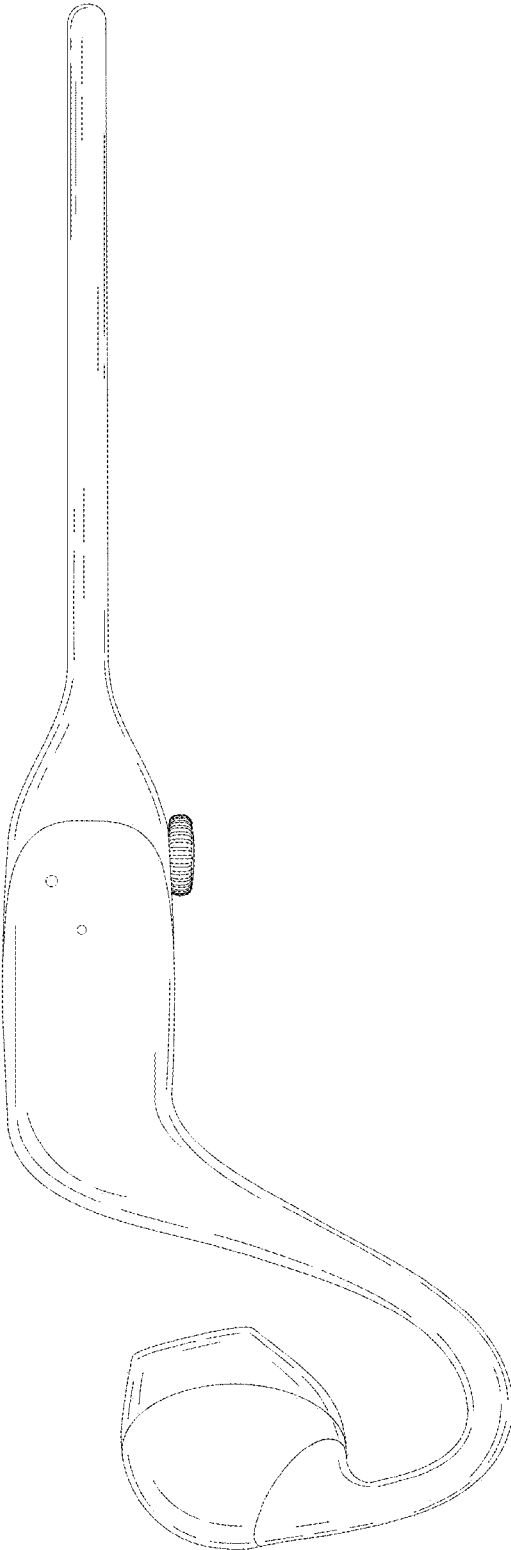

FIG. 5

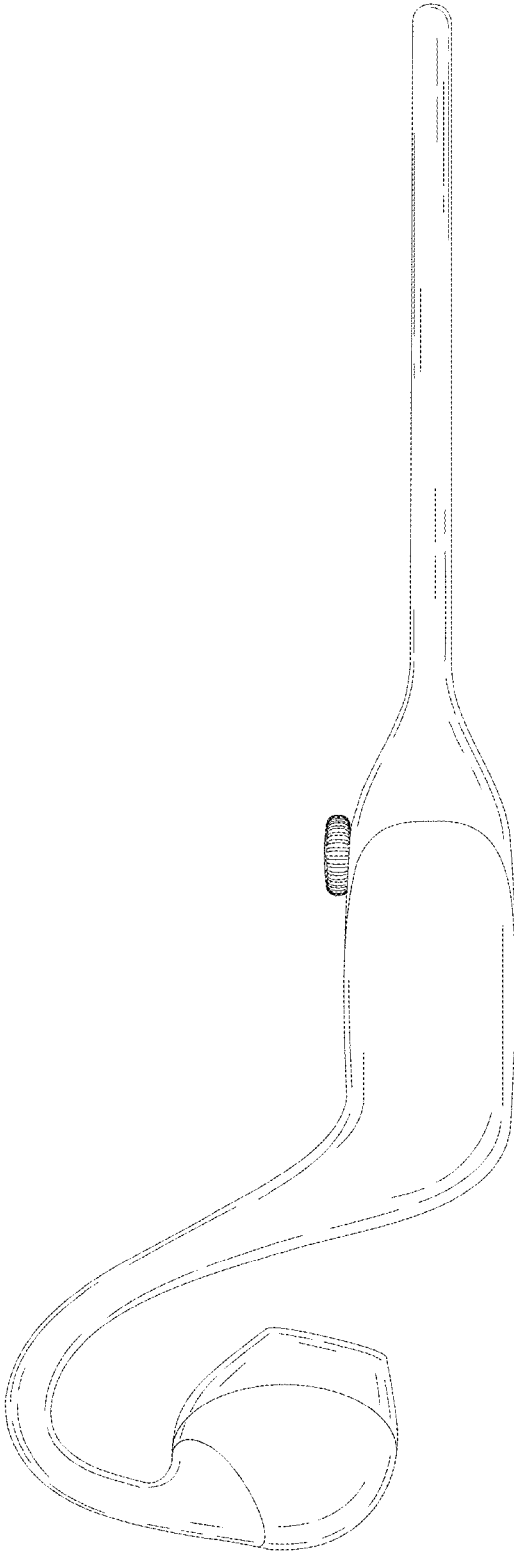

FIG. 6

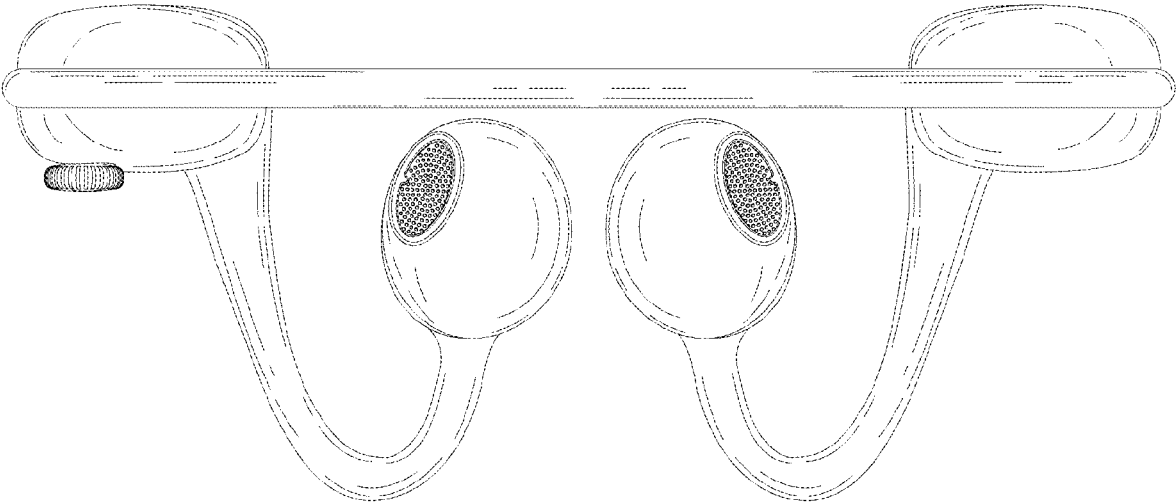

FIG. 7

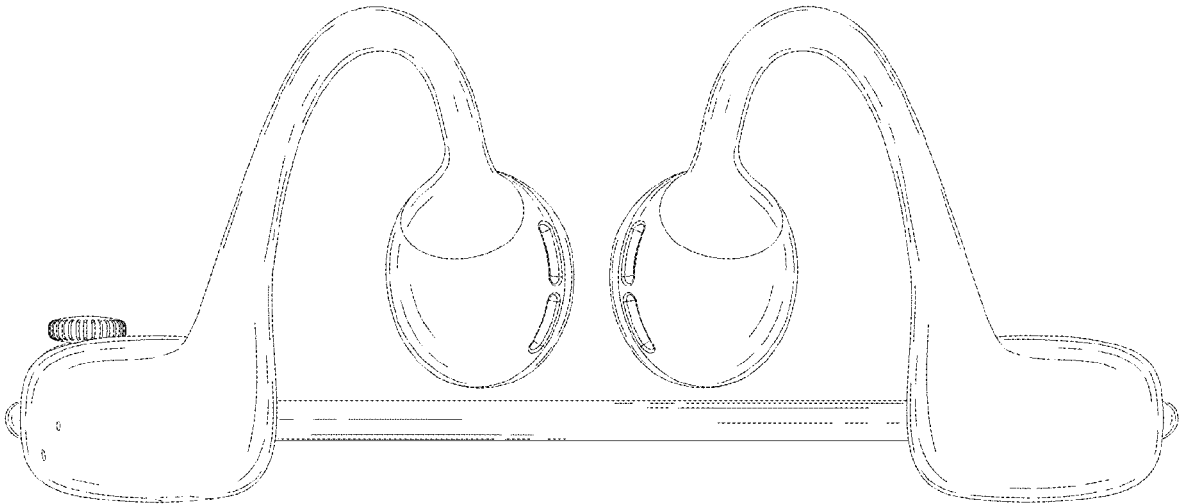

FIG. 8

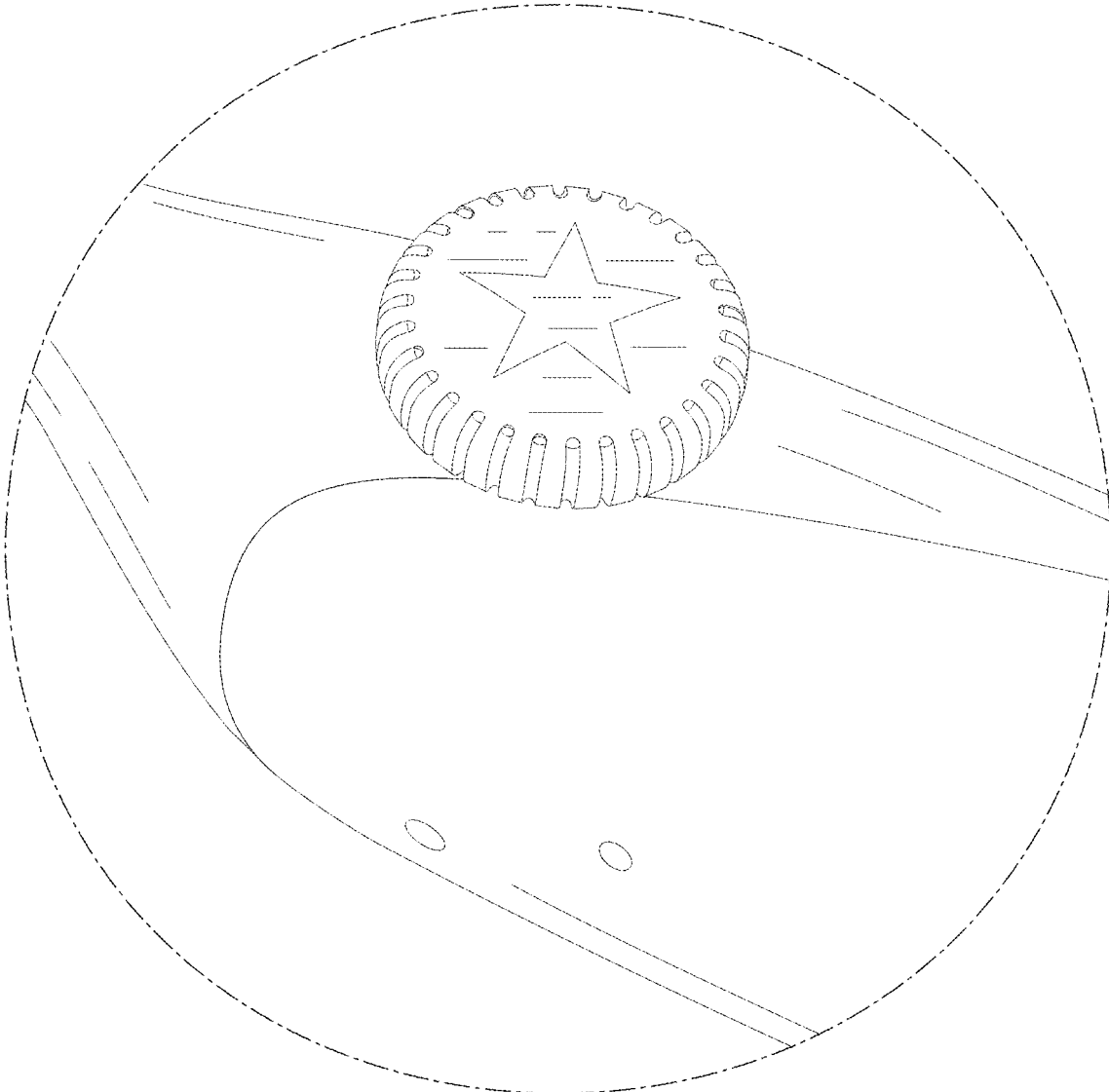

FIG. 9

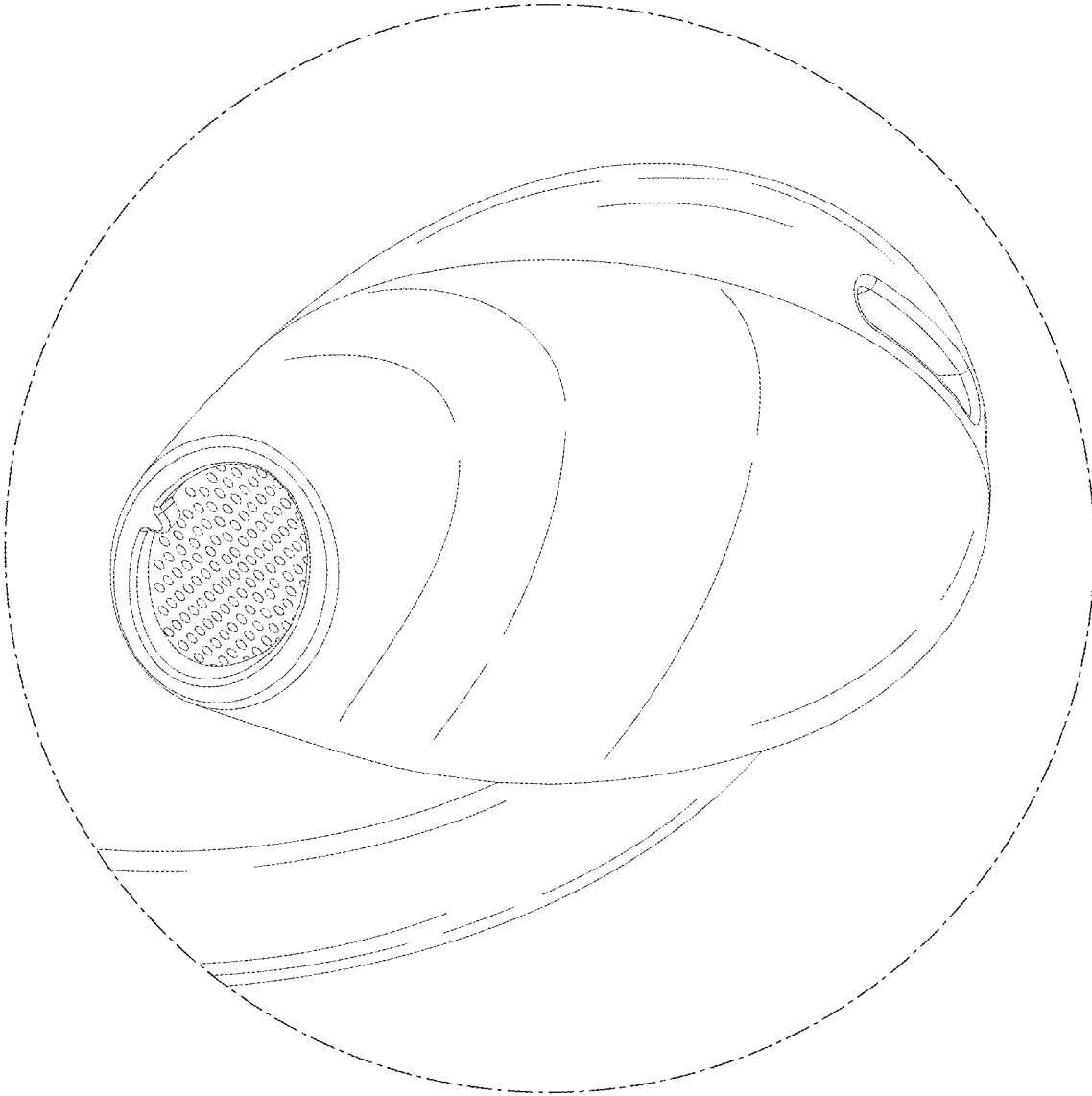

FIG. 10