

Fig. 1

Fig. 2 (Prior Art)

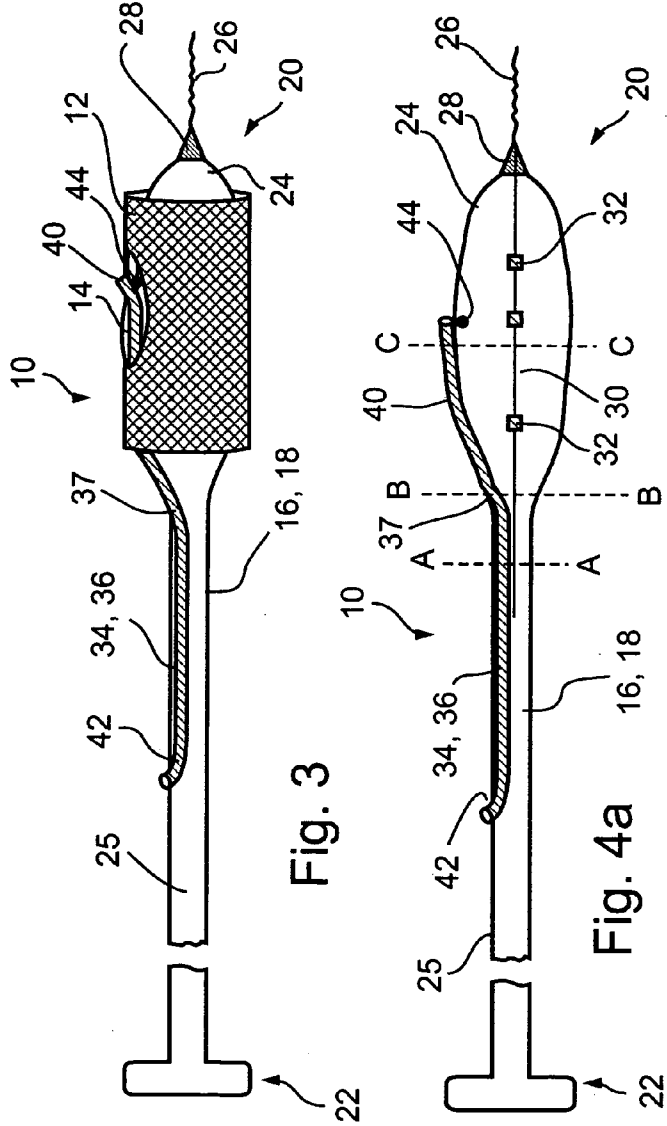

Fig. 3

Fig. 4a

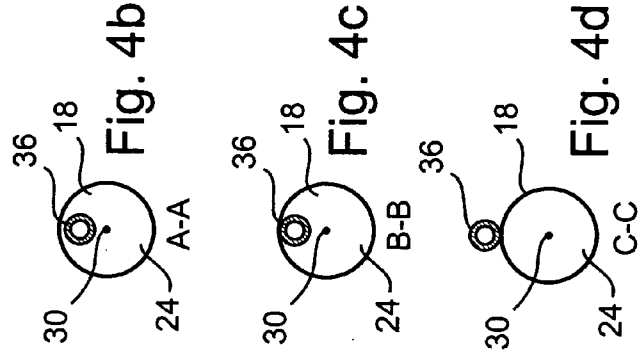

Fig. 4b

Fig. 4c

Fig. 4d

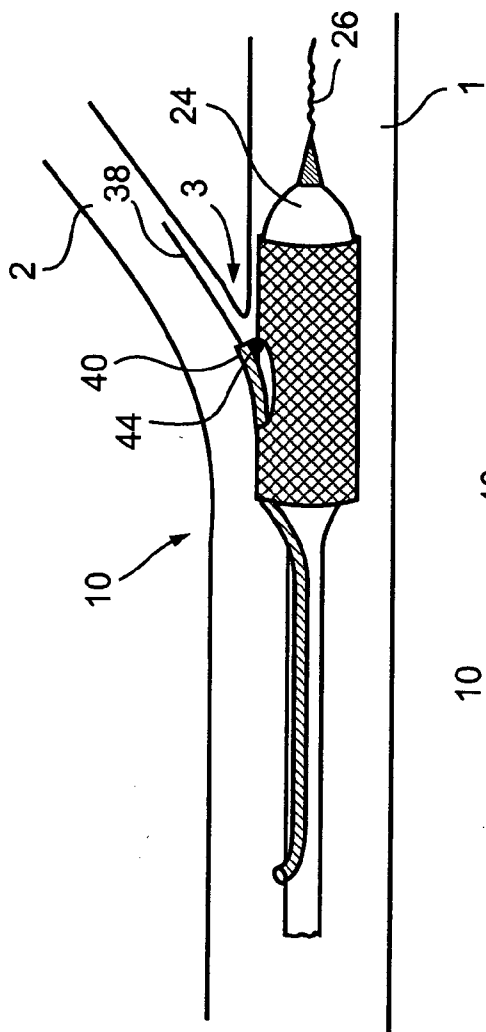

Fig. 5

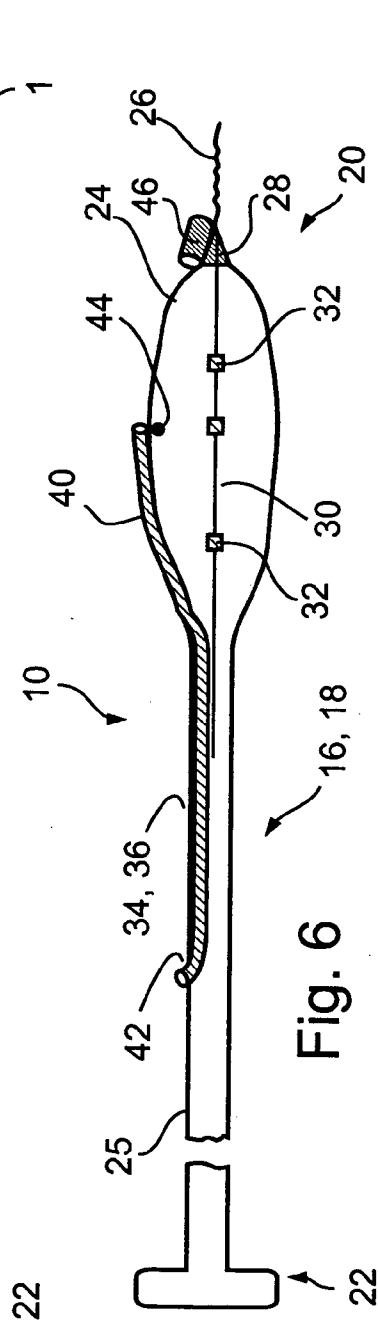

Fig. 6

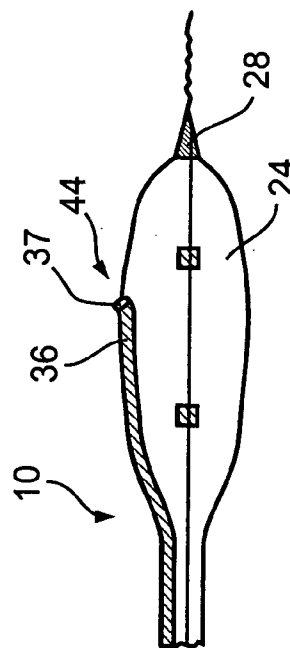

Fig. 7

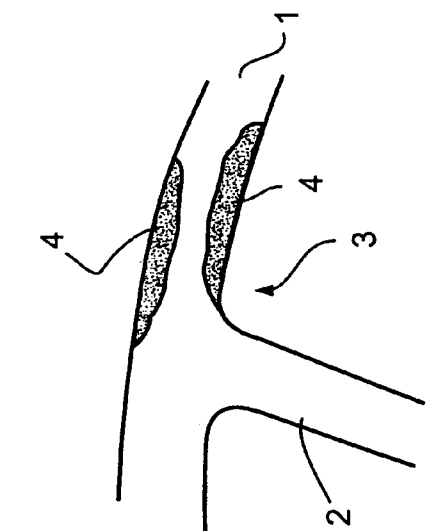

Fig. 10

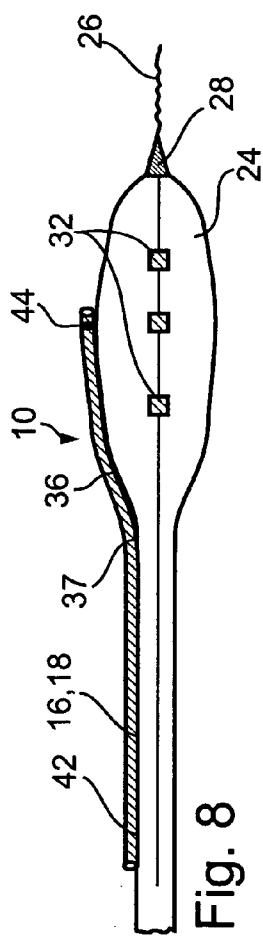

Fig. 8

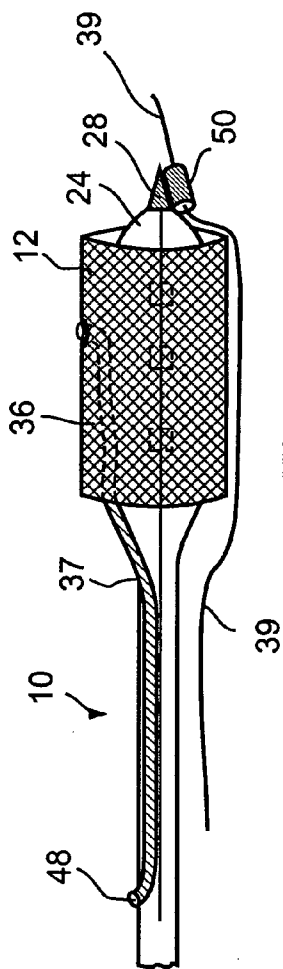

Fig. 9a

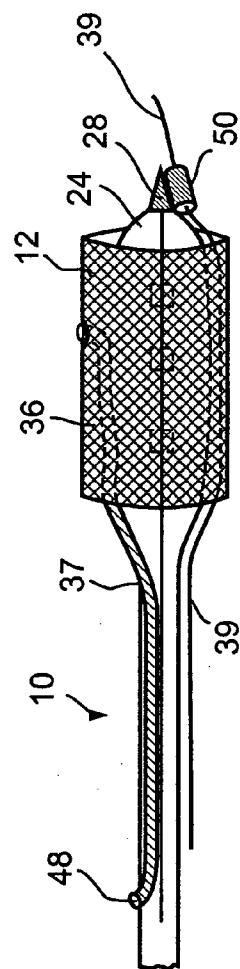

Fig. 9b

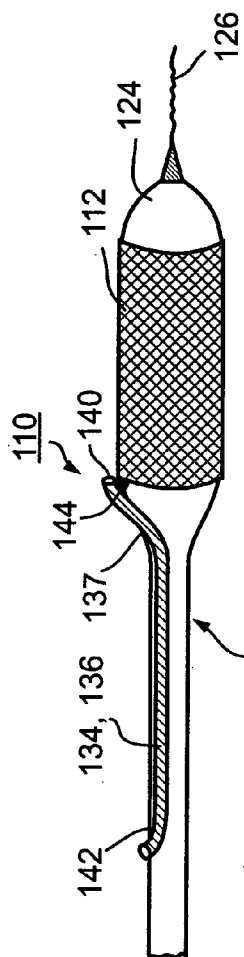

Fig. 11a

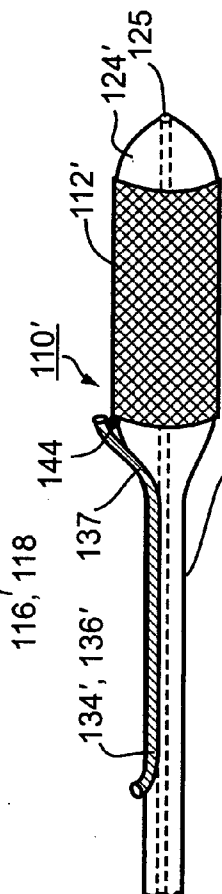

Fig. 11b

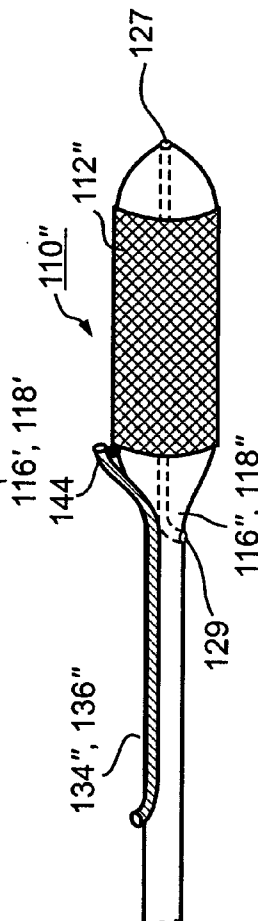

Fig. 11c

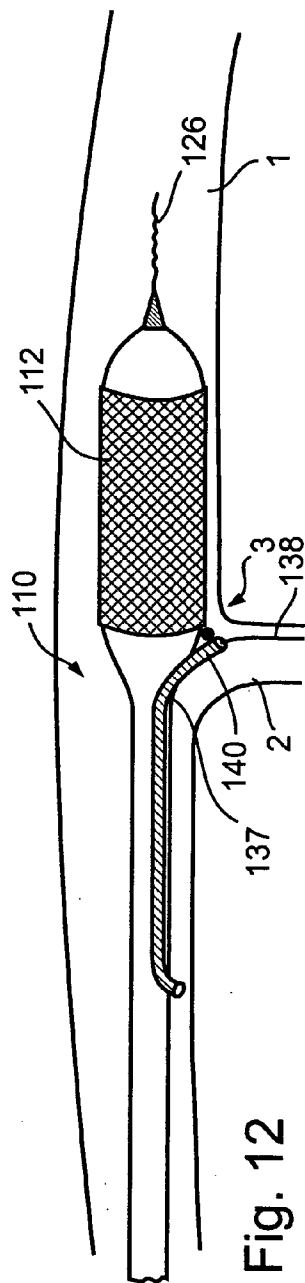

Fig. 12

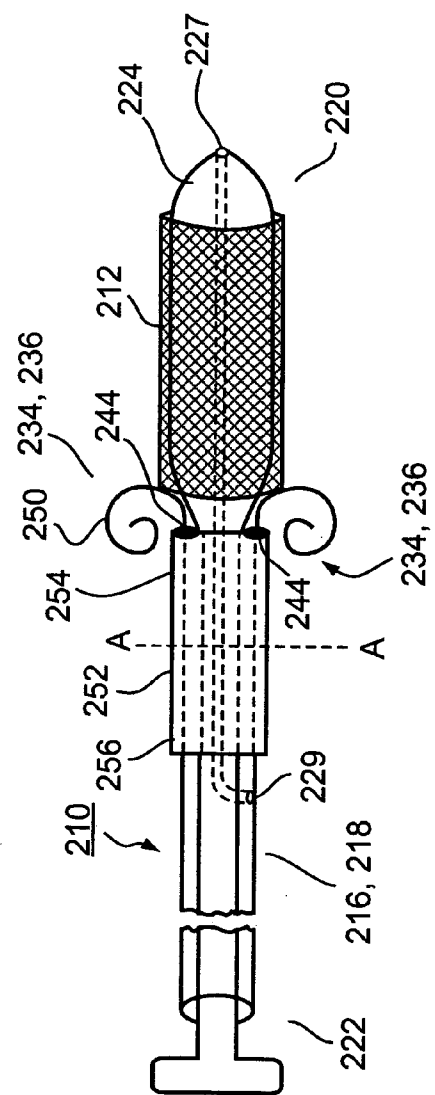

Fig. 13

Fig. 14a

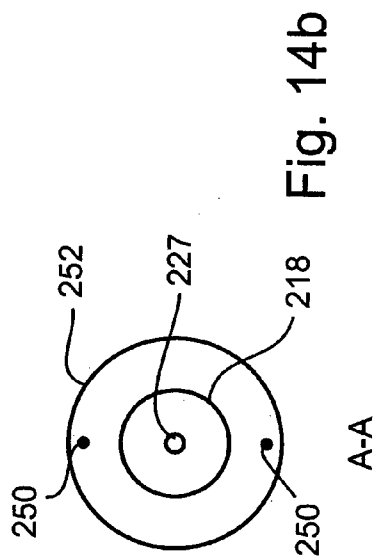

Fig. 14b

A-A

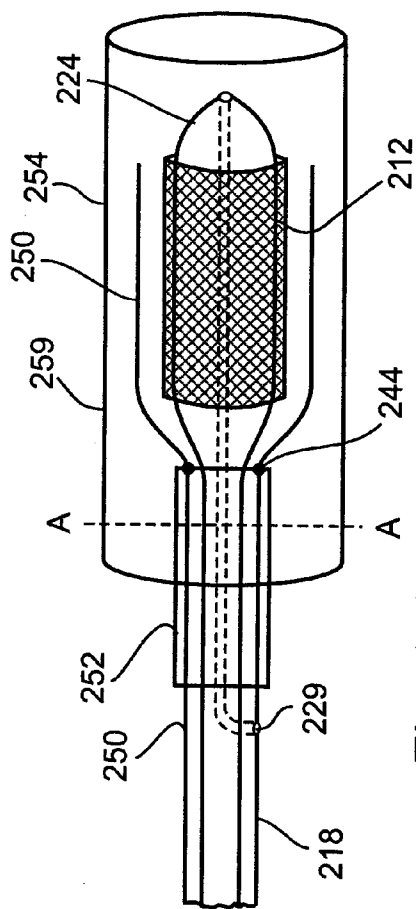

Fig. 15a

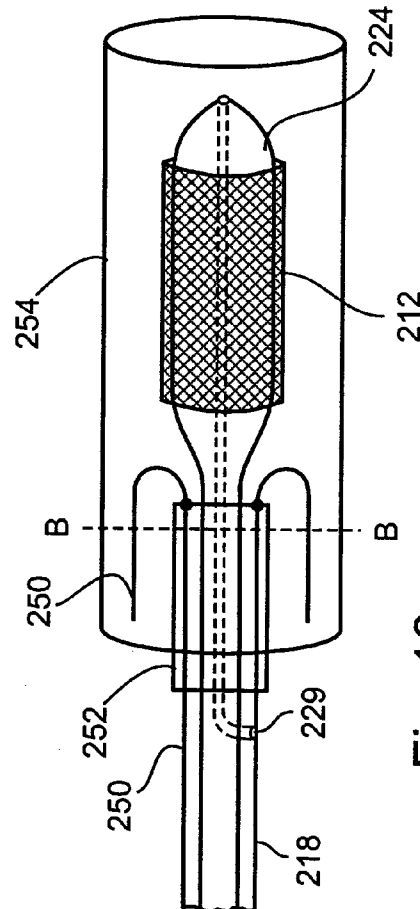

Fig. 16a

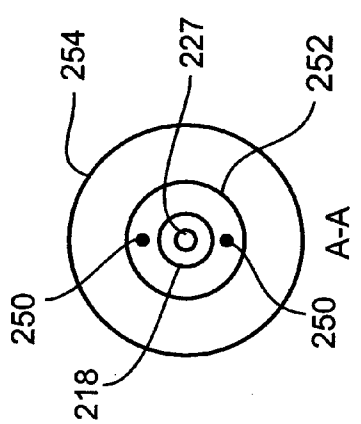

Fig. 15b

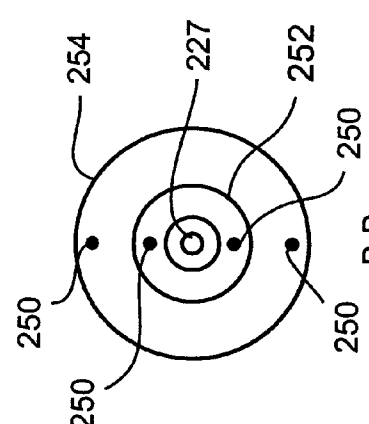

Fig. 16b

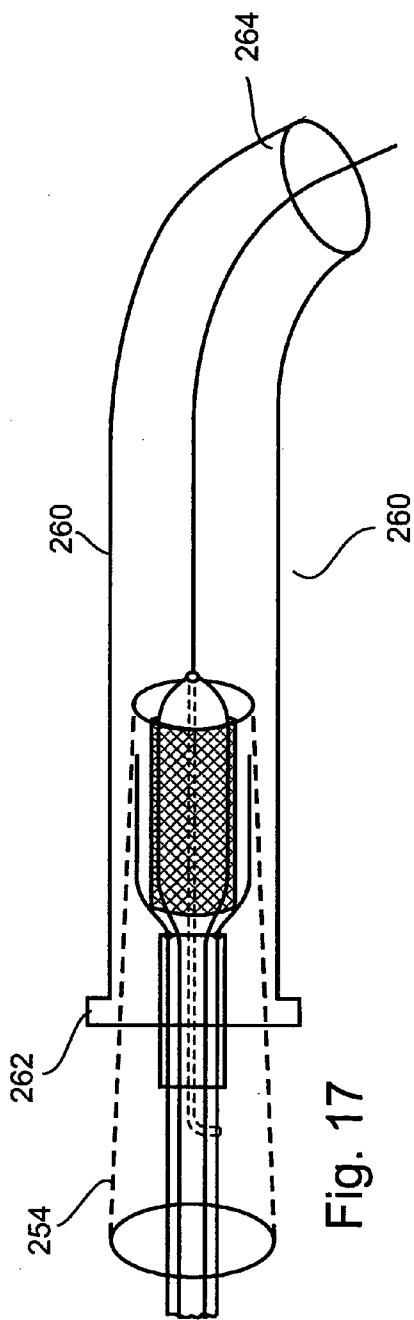

Fig. 17

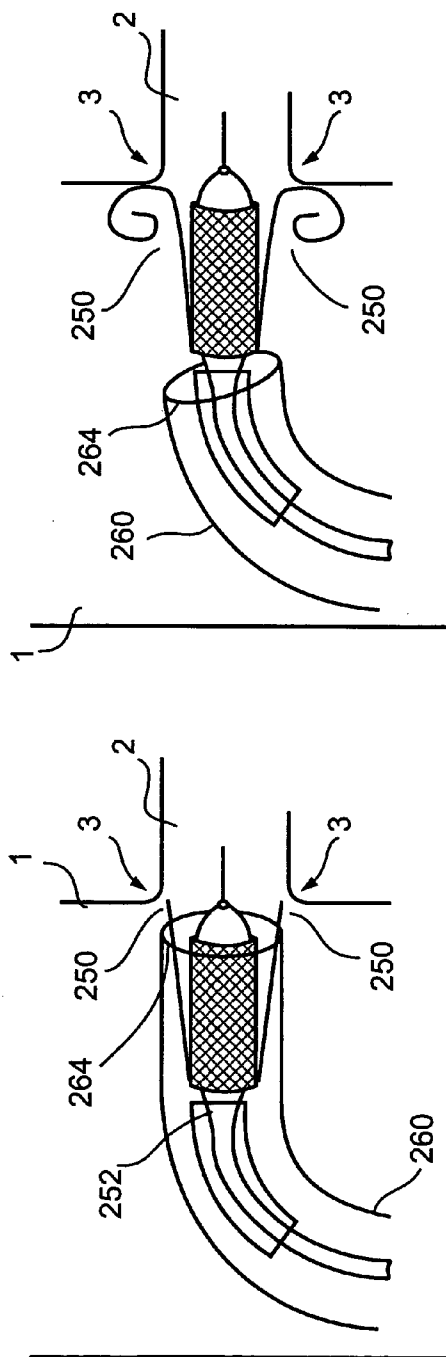
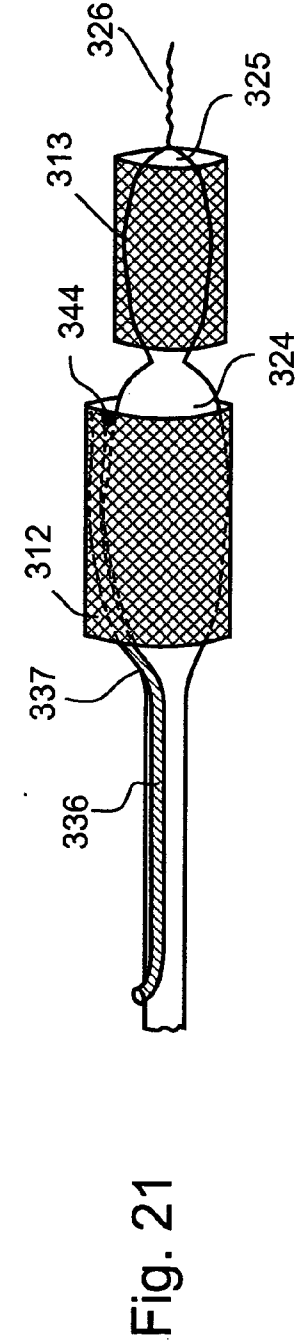
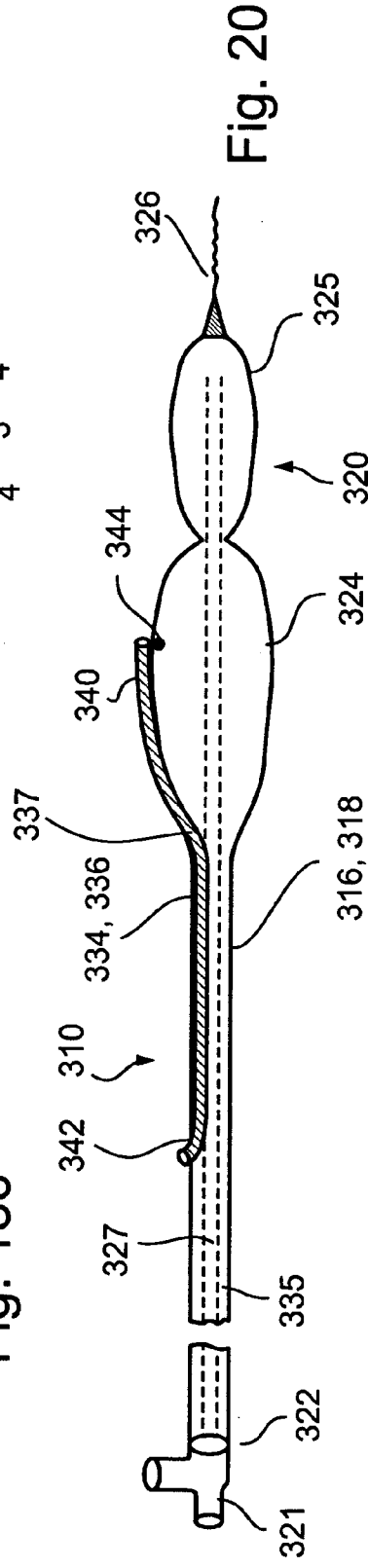
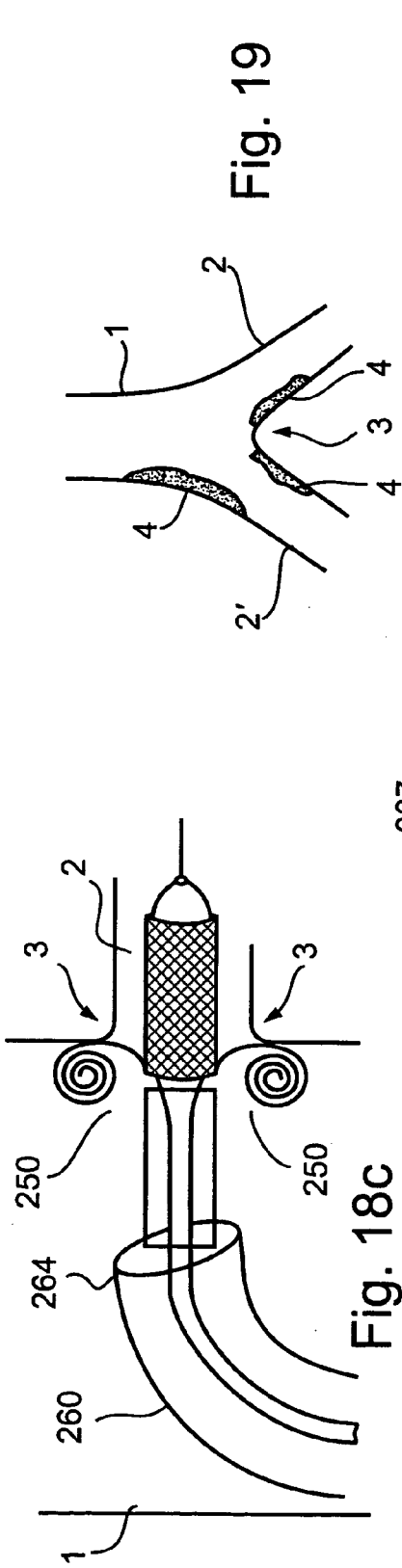

Fig. 18a

Fig. 18b





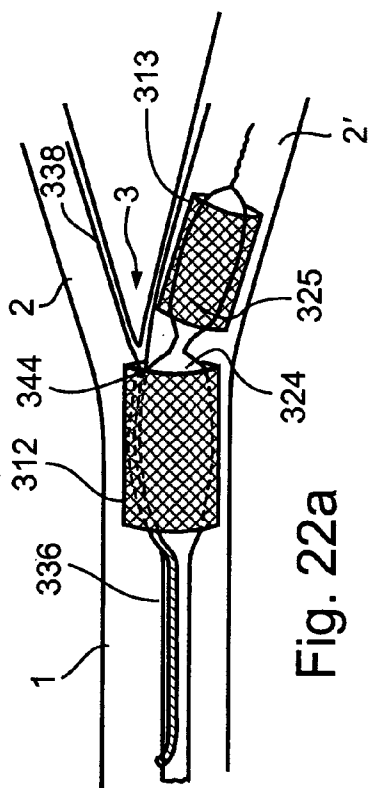

Fig. 22a

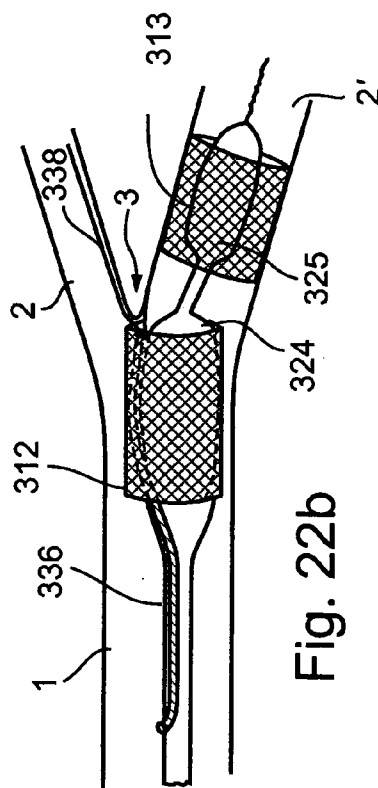

Fig. 22b

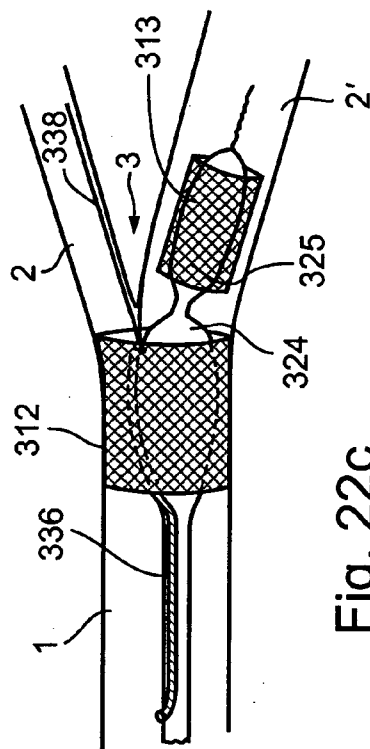

Fig. 22c

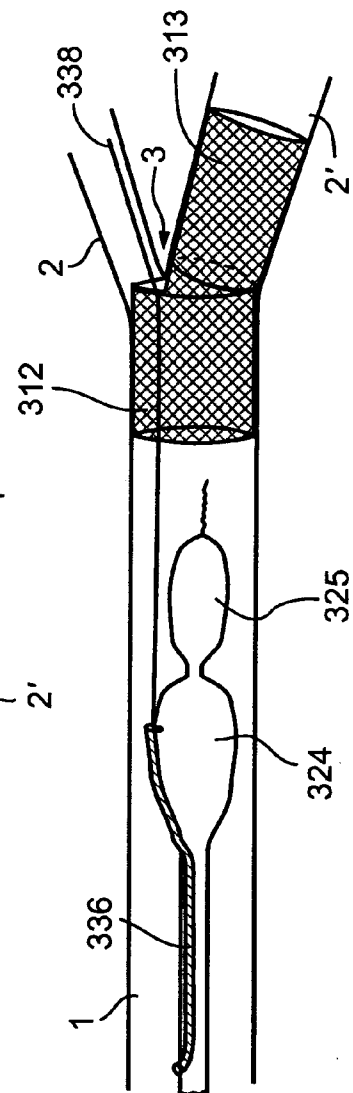

Fig. 22d

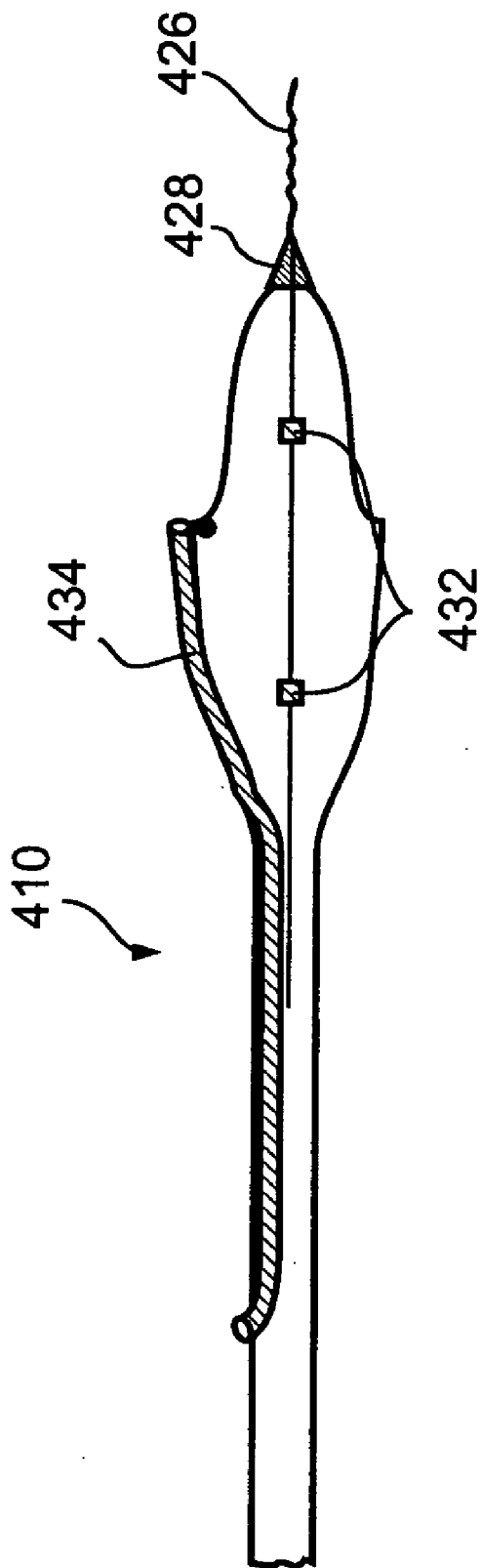

Fig. 23

## BIFURCATION STENT DELIVERY DEVICES

[0001] This application claims the benefit of U.S. Provisional Application No. 60/549,554, filed on Mar. 4, 2004, incorporated herein by reference in its entirety.

### FIELD AND BACKGROUND OF THE INVENTION

[0002] The present invention relates to stent delivery devices and methods and, more particularly, to stent delivery devices for positioning at a bifurcation, the devices having low profiles and predictable positioning capabilities, both rotationally and translationally.

[0003] Several problems are associated with known prior art bifurcation stent delivery devices. First, they generally have large outer diameters, particularly since the known designs usually include two guidewire lumens—one for a main guidewire and one for a side branch guidewire. The relatively large profiles of currently known systems cause difficulties in maneuverability and access to the site. Furthermore, the presence of two guidewires often results in wire entanglement, making the procedure difficult to perform without multiple insertions and retractions. Another problem which persists in these devices is inaccurate positioning within the vessel. This problem has been addressed with the use of radiopaque markers placed in strategic locations. However, visualization is done in the two-dimensional plane, while the actual procedure takes place within the three-dimensional realm. As such, inaccurate deployment is commonplace, often resulting in either stent jailing or insufficient coverage.

[0004] An example of a prior art bifurcation stent delivery system is disclosed in U.S. Pat. No. 6,048,361 to Von Oepen. The system includes a stent with an increased radial opening and a balloon catheter on which the stent is mounted, the balloon catheter having a hollow chamber for passage of a guiding wire so that it exits in a center of the increased opening. The system disclosed therein includes two passageways for guidewires, necessitating a relatively large outer diameter. Furthermore, the presence of two wires can lead to problems of wire entanglement.

[0005] Other examples of prior art bifurcation stent delivery systems and methods are disclosed in U.S. Publication No. 2003/0028233 to Vardi et al. and U.S. Publication No. 2001/0049548 to Vardi et al. These include a balloon catheter having a main guidewire lumen and a flexible side sheath having a side branch lumen. The method disclosed aims to reduce wire entanglement by first inserting one of the guidewires, then advancing the system, and finally advancing the second guidewire. Alternatively, one of the guidewires is housed within the system and only released once the system is in place. However, problems of wire entanglement may also occur upon removal of the system. Furthermore, the system disclosed therein is prone to overshooting of the bifurcation, resulting in sub-optimal placement. Finally, the dual lumen configuration results in a relatively large profile for the overall system.

[0006] Other similar examples of prior art bifurcation stent delivery systems are disclosed in U.S. Pat. No. 5,749,825 to Fischell et al. and U.S. Pat. No. 6,682,556 to Ischinger. The systems disclosed therein include balloon catheters with side branch tubes, and require two guidewires: one for the main

vessel and one for the branch vessel. Similar to the aforementioned prior art, large profile, wire entanglement, and inaccurate positioning are potential problems.

[0007] A prior art device which aims to provide improved rotational orientation while avoiding wire entanglement is disclosed in U.S. Publication No. 2003/0055483 to Gumm. Gumm discloses a catheter assembly having a rotatably mounted balloon, and further including a side branch hollow member attached to the catheter balloon. A noted feature of the device is the use of rotating members sealed to opposite ends of the balloon. Thus, the side branch hollow member, the balloon and the rotating members act as a unit which rotates freely relative to the main hypotube. This particular feature is considered an integral part of the design, providing improved orientation of the stent relative to the side branch at the bifurcation. However, this feature also results in an increased overall diameter of the system. Furthermore, it does not provide a way to accurately position the stent in the translational plane.

[0008] Attempts have been made to reduce the profile of a single stent delivery device by using a fixed wire balloon catheter, such as is disclosed in U.S. Publication No. 2002/0147491 to Khan et al. The device disclosed therein includes either a short section of guidewire fixedly attached to the distal end of a balloon, or a core wire that extends within the system. This design reduces the profile of the system as compared to prior art devices by eliminating the inner guidewire lumen. However, the system disclosed therein does not teach or suggest the possibility of bifurcation stenting, nor does it provide rapid exchange capabilities.

[0009] There is thus a widely recognized need for, and it would be highly advantageous to have, a bifurcation stent delivery system devoid of the above limitations.

### SUMMARY OF THE INVENTION

[0010] According to the present invention there is provided a stent delivery system. The system includes a main elongated element having a proximal end, a distal end and a body connecting the proximal and distal ends, the main elongated element being for advancement within a main vessel, an auxiliary elongated element having a proximal and distal end, the auxiliary elongated element being for advancement within an auxiliary vessel. The auxiliary elongated element is at least partially attached to the main elongated element. The system also includes a crotch point, wherein at the crotch point, the body of the main elongated element is attached to the auxiliary elongated element, and wherein a location of the crotch point is configured to stop advancement of the system upon reaching a bifurcation.

[0011] According to a further aspect of the present invention, there is provided a stent delivery device, including a catheter having a distal end and a proximal end, a balloon positioned on the catheter, the balloon having a distal end and a proximal end, wherein the balloon is immovable with respect to the catheter, a wire attached to the distal end of the balloon, and a side element having a distal end and a proximal end, the side element at least partially attached to the balloon.

[0012] According to a further aspect of the present invention, there is provided a stent delivery system, including a catheter having a distal end and a proximal end, a balloon

positioned on the catheter, the balloon having a distal end and a proximal end, a wire attached to the distal end of the balloon, a side element having a distal end and a proximal end, the side element at least partially attached to the balloon, and a crotch point, wherein at the crotch point, the side element and the balloon are attached, and wherein a location of the crotch point is configured to stop advancement of the system upon reaching a bifurcation.

[0013] According to yet a further aspect of the present invention, there is provided a stent delivery system including a catheter having a distal end and a proximal end, a balloon positioned on the distal end of the catheter, the balloon having a distal end and a proximal end, and wherein the balloon is immovable with respect to the catheter, a stent positioned on the balloon, the stent having a side opening, wherein the side opening has a proximal end and a distal end, and a side branch lumen having a distal end and a proximal end, wherein the proximal end is attached to a proximal end of the balloon, and wherein the distal end is configured to exit through the side opening of the stent.

[0014] According to yet a further aspect of the present invention, there is provided a stent delivery system including a catheter having a distal end and a proximal end, a stent positioned on the catheter, the stent having a distal end and a proximal end, an auxiliary elongated element having a distal end and a proximal end, the auxiliary elongated element positioned outside of the stent, and a crotch point located at the proximal end of the stent whereby the auxiliary elongated element is attached to the catheter at the crotch point.

[0015] According to yet a further aspect of the present invention, there is provided a stent delivery system, including a catheter having a distal end and a proximal end, a distal balloon positioned on the distal end of the catheter, the distal balloon having a distal end and a proximal end, a proximal balloon positioned on the catheter proximal to the distal balloon, a stent positioned on the proximal balloon, the stent having a distal end and a proximal end, an auxiliary elongated element having a distal end and a proximal end, the auxiliary elongated element positioned inside of the stent and exiting at the distal end of the stent, and a crotch point located at the distal end of the stent wherein the auxiliary elongated element is attached to the balloon at the crotch point.

[0016] According to a further aspect of the present invention, there is provided a catheter system including a catheter having a distal end, a proximal end and a body connecting the distal and proximal ends, a side branch lumen having a distal end, a proximal end and a body connecting the distal and proximal ends, wherein a first portion of the side branch lumen is positioned inside the body of said catheter, and a second portion of the side branch lumen is positioned outside the body of the catheter, and an exit point located on the body of said catheter wherein the first portion is proximal to the exit point and the second portion is distal to the exit point.

[0017] According to yet a further aspect of the present invention, there is provided a method for treating a bifurcation, including introducing a side branch guidewire into a side branch vessel, providing a stent delivery system including a main elongated element, a side branch element, and a crotch point, wherein at the crotch point, the main and side

branch elements are attached, and wherein a location of the crotch point is configured to stop advancement of the system when it reaches a bifurcation, and a stent positioned on the main elongated element, inserting a proximal end of the side branch guidewire into the distal end of the side branch lumen, advancing the stent delivery system over the side branch guidewire until a location at which the advancing automatically stops due to the crotch point reaching said bifurcation, and deploying the stent.

[0018] According to yet a further aspect of the present invention, there is provided a method for treating a bifurcation, including providing a stent delivery system, wherein the system includes a catheter having a balloon at a distal end thereof, a fixed wire at a distal end of the balloon, and a side branch lumen at least partially attached to the catheter, wherein a point of attachment defines a stopping point, and advancing the stent delivery system through a main vessel until a location at which the advancing automatically stops due to the crotch point reaching the bifurcation.

[0019] According to further features in preferred embodiments of the invention described below, the main elongated element is a catheter and the auxiliary elongated element is a side branch lumen. In a preferred embodiment, the catheter includes a balloon. The catheter may be a fixed wire balloon catheter, an over-the-wire catheter or a rapid exchange catheter. In one embodiment, the main elongated element is a catheter and the auxiliary elongated element is a positioning system. The positioning system includes at least one stopper, which may be a spring wire, for example, and an attachment mechanism, wherein in one embodiment, the attachment mechanism is a polymer jacket, and wherein the polymer jacket is configured to hold a proximal portion of the spring wire in place, and wherein a distal end of the polymer jacket defines a crotch point.

[0020] In one embodiment, the system includes a stent with a side opening positioned on the main elongated element, and the crotch point is located at a distal portion of the side opening of the stent. In another embodiment, the system includes a stent having a proximal end and a distal end, the stent positioned on the main elongated element, and wherein the crotch point is located at the proximal end of said stent. In yet another embodiment, the system includes a proximal stent having a proximal end and a distal end and a distal stent having a proximal end and a distal end, the proximal stent positioned on the main elongated element and the distal stent positioned distal to the proximal stent on the main elongated element. In this embodiment, the crotch point may be located at the distal end of the proximal stent, and the two stents may be deployed separately. In one embodiment, proximal to the crotch point, the bodies of the main and auxiliary elongated elements are attached. In a preferred embodiment, an outer diameter of the system is less than 1 mm. In an exemplary preferred embodiment, the outer diameter of the system is approximately 0.5 mm.

[0021] According to still further features in the described preferred embodiments, the stent delivery device includes a feature wherein the proximal end of the side branch lumen is positioned within the catheter, and wherein the distal end of the side branch lumen which is detached from the balloon is positioned outside of the catheter. According to still further features, the stent delivery system includes a distal connecting element at the distal end of the balloon. In one

embodiment, the distal connecting element lies on a same side of the catheter as the side branch lumen, and is configured for receiving a side branch guidewire which is positionable through both the side branch lumen and the distal connecting element. In another embodiment, the distal connecting element lies on an opposite side of the catheter as the side branch lumen, and is configured for receiving a main guidewire which is positionable through the distal connecting element and outside of the stent.

[0022] The present invention successfully addresses the shortcomings of the presently known configurations by providing a stent delivery system with a low profile and substantially predictable translational and rotational positioning.

[0023] Unless otherwise defined, all technical and scientific terms used herein have the same meaning as commonly understood by one of ordinary skill in the art to which this invention belongs. Although methods and materials similar or equivalent to those described herein can be used in the practice or testing of the present invention, suitable methods and materials are described below. In case of conflict, the patent specification, including definitions, will control. In addition, the materials, methods, and examples are illustrative only and not intended to be limiting.

#### BRIEF DESCRIPTION OF THE DRAWINGS

[0024] The invention is herein described, by way of example only, with reference to the accompanying drawings. With specific reference now to the drawings in detail, it is stressed that the particulars shown are by way of example and for purposes of illustrative discussion of the preferred embodiments of the present invention only, and are presented in the cause of providing what is believed to be the most useful and readily understood description of the principles and conceptual aspects of the invention. In this regard, no attempt is made to show structural details of the invention in more detail than is necessary for a fundamental understanding of the invention, the description taken with the drawings making apparent to those skilled in the art how the several forms of the invention may be embodied in practice.

[0025] In the drawings:

[0026] FIG. 1 is an illustration of a first type of vessel bifurcation with plaque buildup;

[0027] FIG. 2 is an illustration of a prior art bifurcation stent delivery system;

[0028] FIG. 3 is an illustration of a bifurcation stent delivery system in accordance with a preferred embodiment of the present invention;

[0029] FIGS. 4a-d are illustrations of the system of FIG. 3 shown without a stent;

[0030] FIG. 5 is an illustration of the system of FIG. 3 in position at a bifurcation;

[0031] FIG. 6 is an illustration of a the system of FIG. 3, shown without a stent, and further including a distal connecting element;

[0032] FIG. 7 is an illustration of a bifurcation stent delivery system, shown without a stent, in accordance with another embodiment of the present invention;

[0033] FIG. 8 is an illustration of a bifurcation stent delivery system, shown without a stent, in accordance with yet another embodiment of the present invention;

[0034] FIGS. 9a and 9b are illustrations of a bifurcation stent delivery system in accordance with another embodiment of the present invention;

[0035] FIG. 10 is an illustration of a second type of vessel bifurcation with plaque buildup;

[0036] FIG. 11a-c are illustrations of a system for treating a bifurcation such as the one depicted in FIG. 10;

[0037] FIG. 12 is an illustration of the system of FIG. 11a in position at a bifurcation;

[0038] FIG. 13 is an illustration of a third type of vessel bifurcation with plaque buildup;

[0039] FIGS. 14a and b are illustrations of a system for treating a bifurcation such as the one depicted in FIG. 13;

[0040] FIGS. 15a and b are illustrations of the system of FIG. 14, further including a holder;

[0041] FIGS. 16a and b are illustrations of the system of FIG. 14, further including a holder, in an alternative embodiment;

[0042] FIG. 17 is an illustration of the system of FIG. 14 being introduced into a guiding catheter;

[0043] FIGS. 18a-c are illustrations of the system of FIG. 14 during positioning and deployment;

[0044] FIG. 19 is an illustration of a fourth type of vessel bifurcation with plaque buildup;

[0045] FIG. 20 is an illustration of a system, shown without a stent, for treating a bifurcation such as the one depicted in FIG. 19;

[0046] FIG. 21 is an illustration of the system depicted in FIG. 20, further including stents thereon;

[0047] FIGS. 22a-d are illustrations of a method of deploying the system of FIG. 20; and

[0048] FIG. 23 is an illustration of a tapered balloon system with a side branch lumen, in accordance with another embodiment of the present invention.

#### DESCRIPTION OF THE PREFERRED EMBODIMENTS

[0049] The present invention is of a stent delivery system and method for delivery of a stent to a bifurcation area. Specifically, the present invention can be used to position a stent at a bifurcation with rotational and translational alignment. In addition to providing substantially predictable alignment, the devices and systems of the present invention have small outer diameters as compared with prior art bifurcation stent delivery systems, and reduce the possibility of wire entanglement.

[0050] The principles and operation of a stent delivery system according to the present invention may be better understood with reference to the drawings and accompanying descriptions.

[0051] Before explaining at least one embodiment of the invention in detail, it is to be understood that the invention

is not limited in its application to the details of construction and the arrangement of the components set forth in the following description or illustrated in the drawings. The invention is capable of other embodiments or of being practiced or carried out in various ways. Also, it is to be understood that the phraseology and terminology employed herein is for the purpose of description and should not be regarded as limiting.

[0052] Reference is now made to **FIG. 1**, which is an illustration of vessel bifurcation with plaque buildup. A main vessel **1** and a branch vessel **2** are connected at a bifurcation point **3**. A buildup of plaque **4** may be found anywhere within the vessels, but if there is plaque buildup located at or close to bifurcation point **3**, as shown in **FIG. 1**, the location presents a specific challenge with regard to accurate stent placement. Stents placed at bifurcations are typically deployed either slightly proximal or slightly distal to the bifurcation point, which can lead to stent jailing and/or insufficient coverage.

[0053] Reference is now made to **FIG. 2**, which is an illustration of a prior art bifurcation stent delivery system **5**. System **5** includes a catheter **6** having a stent **7** with a dedicated side hole **8**. A main guidewire **9** is positioned in main vessel **1** and passed through a main guidewire lumen in catheter **6**. A side branch guidewire **11** is positioned within a second guidewire lumen, through side hole **8**, and into branch vessel **2**. As shown in **FIG. 1**, there is a tendency for system **5** to overshoot bifurcation point **3** during placement. Additionally, prior art bifurcation stent systems are generally large in diameter due to the presence of two guidewire lumens—one for main guidewire **9** and one for branch guidewire **11**. Furthermore, the two wires often become entangled with one another, causing a failure in delivery and/or removal of the system.

[0054] The present invention seeks to address the limitations of prior art systems, by providing substantially predictable positioning and alignment, both translationally and rotationally within the vessel, while retaining a small profile and eliminating wire crossing so as to provide ease of delivery. Several different embodiments of the invention provide solutions for different types of bifurcations, as will be described in further detail hereinbelow.

[0055] Bifurcation Type I:

[0056] In a first embodiment, a stent delivery system **10** is designed to be delivered at a bifurcation, such as the one illustrated in **FIG. 1**, having a main vessel **1** and a branch vessel **2**, wherein the plaque **4** is located within the main vessel in the vicinity of bifurcation point **3**.

[0057] Reference is now made to **FIG. 3** and **FIGS. 4a-d**, which are illustrations of a bifurcation stent delivery system **10**, shown with and without a stent respectively. System **10** includes a main elongated element **16**, and an auxiliary elongated element **34** aligned with main elongated element **16**. In a preferred embodiment, auxiliary elongated element **34** is positioned within main elongated element **16** proximal to an exit point **37** and alongside main elongated element **16** distal to exit point **37**, as depicted in **FIG. 3**. In an alternative embodiment, auxiliary elongated element **34** is positioned alongside main elongated element **16**, as will be described hereinbelow with reference to **FIG. 8**.

[0058] In a preferred embodiment, main elongated element **16** is a catheter **18** having a distal end **20** and a

proximal end **22**. A balloon **24** is positioned on distal end **20** of catheter **18**. Catheter **18** includes a hypotube **25** running along the length of the catheter, and an inflation lumen within hypotube **25** in communication with balloon **24**. The inflation lumen is designed for introducing a fluid, preferably a liquid, into balloon **24** for inflation of balloon **24** at the appropriate location. A port for inflation is positioned at proximal end **22**, in a configuration which is well known in the art. Catheter **18** shown in **FIGS. 3** and **4a-d** may be any commercially available balloon catheter. Optionally, a torquer device may be introduced to proximal end **22** for improving torquability. Such torquer devices are well known in the art.

[0059] In an exemplary preferred embodiment, balloon **24** is a fixed wire balloon and as such, includes a fixed wire **26** attached to a distal end of balloon **24** at a bonding area **28**. A fixed wire skeleton **30** runs along the interior of balloon **24** to provide rigidity. Fixed wire balloons are known in the art, and may be obtained from, for example, Boston Scientific Scimed [ACE balloon, catalog number 02071-04].

[0060] System **10** includes a stent **12** positioned on main elongated element **16**, the stent **12** having a side opening **14**. In one embodiment, side opening **14** is a dedicated side opening, and in another embodiment, side opening **14** is any opening within the structure of stent **12**. In a preferred embodiment, auxiliary elongated element **34** is a side branch lumen **36** for placement of a side branch guidewire therethrough. Side branch lumen **36** has a distal end **40** and a proximal end **42** and is attached to catheter **18** at proximal end **42** and unattached to catheter **18** at distal end **40**. The point at which the detachment between main and auxiliary elongated elements (catheter **18** and side branch lumen **36** in the present embodiment) occurs is defined as a crotch point **44**. In an alternative embodiment, side branch lumen **36** is unattached to catheter **18** both proximal and distal to crotch point **44**, and is attached to catheter **18** only at crotch point **44**. Balloon **24** further includes fluorescent markers **32** which can be visualized during a procedure under fluorescence. In a preferred embodiment, markers **32** are located at both ends of stent **12** and at a location which is aligned with crotch point **44**. In alternative embodiments, any configuration on markers which would enable viewing of key locations of system **10** can be used.

[0061] Crotch point **44** is preferably located close to distal end **40** of side branch lumen **36**. It should be noted that the depiction of crotch points in the figures is for indication purposes only, and that crotch points may not include an actual connecting element as shown. The length of the unattached portion is preferably less than 1 mm. In an exemplary preferred embodiment, the length of the unattached portion is approximately 0 mm, i.e. the distal end **40** of side branch lumen **36** is at crotch point **44**. It should be noted that in this embodiment, a guidewire within side branch lumen **36** is configured to enter a side branch vessel, as will be described hereinbelow with reference to **FIG. 5**. This guidewire positioned within side branch lumen **36**, and main elongated element **16** form crotch point **44**. In an alternative embodiment, the length of the unattached portion is approximately 1-5 mm, or more preferably approximately 2 mm. Side branch lumen **36** may be as long or as short as necessary, both proximally and distally. In a preferred embodiment, the portion of side branch lumen **36** which is proximal to crotch point **44** is approximately 10-30 mm, and

in an exemplary preferred embodiment is approximately 25 mm. By extending side branch lumen 36 proximally along at least a portion of hypotube 25, the rigidity of system 10 is increased, thus providing ease of rotation within the vessel. In an alternative embodiment, the portion of side branch lumen 36 which is proximal to crotch point 44 is approximately 5-15 mm.

[0062] A cross-sectional view along lines A-A, B-B and C-C are depicted in FIGS. 4b, 4c and 4d, respectively. As shown in FIG. 4b, at a proximal location, side branch lumen 36 is located within catheter 18. Fixed wire skeleton 30 is in the center, and side branch lumen 36 is between fixed wire skeleton 30 and the edge of catheter 18. As shown in FIG. 4c, at exit point 37, side branch lumen 36 is bonded to catheter 18. Distal to exit point 37, side branch lumen 36 is outside and adjacent to balloon 24, as shown in FIG. 4d.

[0063] Reference is now made to FIG. 5, which is an illustration of system 10 positioned at a bifurcation. Crotch point 44 is a key element in positioning of stent 12 within the vessel. With catheter 18 in main vessel 1 and a side branch guidewire 38 within side branch lumen 36 positioned in branch vessel 2, system 10 cannot be advanced beyond the point at which crotch point 44 reaches bifurcation point 3. Thus, system 10 is substantially predictably aligned, and overshooting is prevented.

[0064] In an exemplary preferred embodiment, a method for introducing system 10 is as follows. First, a side branch guidewire 38 is positioned within branch vessel 2. A proximal end of side branch guidewire 38 is introduced into distal end 40 of side branch lumen 36. With side branch guidewire 38 positioned within side branch lumen 36, system 10 is advanced through main vessel 1. Fixed wire 26 provides guidance as advancement occurs. In an alternative embodiment, side branch guidewire 38 is not introduced initially, and system 10 is advanced using only fixed wire 26 as a guide. In either case, system 10 is free to rotate without risk of entanglement. When crotch point 44 reaches bifurcation point 3, advancement of system 10 automatically stops. At this point, system 10 is in place, with side branch guidewire 38 in branch vessel 2, and stent 12 in a correct position both translationally and rotationally. Balloon 24 is then inflated, thus deploying stent 12 within the vessel. Thus, the exact location of crotch point 44 predetermines accuracy of positioning. After deployment, system 10 is removed from branch vessel 2. A particular feature of the invention as described is the ability to provide rapid exchange of catheters via branch guidewire 38, if necessary.

[0065] It should be apparent that the specific features of the present invention allow for accurate positioning in both the rotational and the translational direction, while providing a small outer diameter overall. In a preferred embodiment, the overall outer diameter is 0.5-1.5 mm. Specifically, by attaching side branch lumen 36 directly to balloon 24, for example, and predetermining the location of crotch point 44, side branch lumen 36 acts as a guide in the translational plane. The use of a fixed wire provides torquability and ease of rotation, particularly since there is only one guidewire present (i.e. the branch guidewire). The configuration of side branch lumen 36 wherein a distal end 40 thereof is unattached to main elongated element 16, or wherein a guidewire placed therethrough is unattached to main elongated element 16 allows for initial entry of side branch lumen 36 into

branch vessel 2. These aspects allow for substantially predictable rotation of the system and substantially predictable rotational positioning, without wire entanglement.

[0066] Reference is now made to FIG. 6, which is an illustration of system 10 in accordance with an alternative embodiment of the present invention. As shown in FIG. 6, system 10 further includes a distal connecting element 46, attached to a distal end of balloon 24. In a preferred embodiment, distal connecting element 46 is attached at bonding area 28 of balloon 24. In an alternative embodiment, distal connecting element 46 is attached at any other location on balloon 24 which is distal to side branch lumen 36. Distal connecting element 46 is configured to hold side branch guidewire 38 in place until system 10 is in the vicinity of bifurcation 3. This prevents side branch guidewire 38 from moving around within the vessel during delivery of system 10, possibly causing damage. Once system 10 is within the general vicinity of bifurcation 3, side branch guidewire 38 is pulled proximally and released from distal connecting element 46, after which it is advanced into branch vessel 2. System 10 is then advanced until crotch point 44 prevents further advancement, balloon 24 is inflated, and stent 12 is deployed.

[0067] Reference is now made to FIG. 7, which is an illustration of system 10 in accordance with yet another embodiment of the present invention. As shown in FIG. 7, side branch lumen 36 is located internally within balloon 24, and includes an exit point 37 at a location along balloon 24. The location of exit point 37 with respect to stent 12 defines a crotch point, which coincides with the location of crotch point 44 described in the earlier embodiments, and is functionally equivalent thereto. In one embodiment, side branch lumen 36 ends at crotch point 44. In an alternative embodiment, side branch lumen 36 extends distally beyond crotch point 44.

[0068] Reference is now made to FIG. 8, which is an illustration of system 10 in accordance with yet another embodiment of the present invention. Side branch lumen 36 is located external and adjacent to main elongated element 16. Crotch point 44 is located distal at an attachment point between side branch lumen 36 and balloon 24. The portion of side branch lumen 36 which lies between exit point 37 and crotch point 44 may be attached or unattached to balloon 24.

[0069] Reference is now made to FIGS. 9a and 9b, which are illustrations of system 10 in accordance with yet another embodiment of the present invention, shown with a stent thereon. In this depiction, side hole 14 is not a dedicated side hole, but rather is any opening within the body of stent 12. It should be noted that this type of side hole may be found on any of the embodiments described herein. System 10 includes a main guidewire 39 rather than a fixed wire at the distal end of balloon 24. A main guidewire lumen 50 is located at bonding area 28 of balloon 24. In a preferred embodiment, main guidewire lumen 50 is relatively short, i.e. 1-5 mm. In alternative embodiments, main guidewire lumen 50 extends proximally along a side of balloon 24. In a preferred embodiment, main guidewire 39 is positioned outside of stent 12 so as to avoid wire crossing between main guidewire 39 and side branch guidewire 38, as shown in FIG. 9a. In an alternative embodiment, main guidewire 39 is positioned within stent 12, as shown in FIG. 9b. In a



preferred embodiment, main guidewire lumen 50 is positioned on an opposite side from side branch lumen 36, as depicted.

[0070] In an alternative embodiment (not shown) of the present invention, system 10 includes a main guidewire lumen in place of a fixed wire, and further includes a crotch point 44 in accordance with the different embodiments described above.

[0071] Bifurcation Type II:

[0072] In a second embodiment, a stent delivery system 110 is designed to be delivered at a bifurcation as illustrated in FIG. 10, having a main vessel 1 and a branch vessel 2 at an angle with respect to main vessel 1, and wherein plaque 4 is located in main vessel 1 at an area of a bifurcation 3. One example of such a location is the coronary artery, where blockage of, for example, the left anterior descending (LAD) artery is to be avoided while providing coverage to the plaque within the coronary artery. Other examples include renal arteries, the left main coronary artery, vein grafts, and others.

[0073] Reference is now made to FIGS. 11a-c, which are illustrations of different embodiments of a system 110 for delivery of a stent at a bifurcation such as the one depicted in FIG. 10. System 110 may be designed with a fixed wire, as shown in FIG. 11a, as an over-the-wire system, as shown in FIG. 11b, or as a rapid exchange system, as shown in FIG. 11c.

[0074] Reference is now made to FIG. 11a, which is an illustration of system 110 designed as a single wire system. System 110 includes a main elongated element 116 and an auxiliary elongated element 134. In a preferred embodiment, main elongated element 116 is a catheter 118. In a preferred embodiment, catheter 118 includes a balloon 124 with a fixed wire 126 at a distal end thereof. A stent 112 is positioned on balloon 124. In a preferred embodiment, auxiliary elongated element 134 is a side branch lumen 136, and is attached to catheter 118 at a crotch point 144. Side branch lumen 136 has a proximal end 142 and a distal end 140. In a preferred embodiment, side branch lumen 136 is positioned within catheter 118 proximally, exits at an exit point 137, and is attached to main elongated element 116 at crotch point 144. The portion of side branch lumen 136 between exit point 137 and crotch point 144 may be attached or unattached. In a preferred embodiment, a distal end of side branch lumen 136 is at crotch point 144, and a guidewire placed therethrough extends distally to provide a stopping point. In an alternative embodiment, the distal end of side branch lumen is located 1-5 mm distal to crotch point 144, and is unattached to the catheter 118 in this location.

[0075] In an alternative embodiment, side branch lumen 136 is located external to and positioned alongside catheter 118 proximal to crotch point 144, and is unattached to elongated element 116 distal to crotch point 144. In an alternative embodiment, side branch lumen 136 is unattached to catheter 118 both proximal to and distal to crotch point 144. Crotch point 144 is located at or near a proximal end of stent 112. In a preferred embodiment, crotch point 144 is just proximal to the proximal end of stent 112.

[0076] Reference is now made to FIG. 11b, which is an illustration of system 110' designed as an over-the-wire, double rail system. System 110' is similar to system 110

shown in FIG. 11a, except that in place of a fixed wire on the distal end of balloon 124', a main guidewire lumen 125 is present and runs the length of catheter 118'. A main guidewire is positioned through main guidewire lumen 125 for entry into main vessel 1. System 110' may be introduced to the site via a main guidewire located in main guidewire lumen 125 or via a branch guidewire located in side branch lumen 136'.

[0077] Reference is now made to FIG. 11c, which is an illustration of system 110", designed as a rapid exchange dual wire system. System 110" is similar to both systems 110 and 110' depicted in FIGS. 11a and 11c, except that in place of a fixed wire or a main guidewire lumen running the length of catheter 118", a short main guidewire lumen 127 is present and runs proximally until an exit point 129. These types of systems are well known in the art, and are known to provide ease of catheter exchange. In the present invention, the location of crotch point 144 allows for more accurate placement within the vessel.

[0078] Reference is now made to FIG. 12, which is a depiction of system 110 positioned at bifurcation 3. A side branch guidewire 138 is introduced into branch vessel 2. System 110 is guided over side branch guidewire 138 and either fixed wire 126 or a main guidewire 139, depending on the type of system, until crotch point 144 of side branch lumen 136 is at bifurcation point 3. In a preferred embodiment, distal end 140 is at crotch point 144, and only guidewire 138 enters branch vessel 2. In an alternative embodiment, side branch lumen 136 extends and into side branch vessel 2. System 110 is slowly advanced until crotch point 144 reaches bifurcation point 3, after which system 110 automatically stops advancing. Balloon 124 is then inflated, deploying stent 112. After deployment, balloon 124 is deflated, and system 110 is removed.

[0079] Bifurcation Type III:

[0080] In a third embodiment, a stent delivery system 210 is designed to be delivered at a bifurcation such as the one illustrated in FIG. 13, having a main vessel 1 and a branch vessel 2 at an angle with respect to main vessel 1, and wherein plaque 4 is located in branch vessel 2 at an area of a bifurcation 3. In an exemplary preferred embodiment, main vessel 1 is an aorta.

[0081] Reference is now made to FIGS. 14a and 14b, which are views of a system 210 in accordance with an embodiment of the present invention. System 210 includes a main elongated element 216 and an auxiliary elongated element 234. In a preferred embodiment, main elongated element 216 is a catheter 218 having a proximal end 222 and a distal end 220. Catheter 218 has a balloon 224 at distal end 220, with a stent 212 positioned thereon. In one embodiment, balloon 224 includes a main guidewire lumen 227. In an alternative embodiment, balloon 224 is a fixed wire balloon, such as described with reference to the first and second embodiments, and shown at least in FIGS. 4a and 11a. In a preferred embodiment, main guidewire lumen 227 extends only partially in the proximal direction along catheter 218 and includes an exit point 229 for rapid exchange. In an alternative embodiment, system 210 is an over-the-wire system and main guidewire lumen 227 extends proximally to the proximal end of catheter 218. In a preferred embodiment, auxiliary elongated element 234 is a positioning system 236, which will be described in further detail hereinbelow.

[0082] In a preferred embodiment, positioning system 236 includes a stopper element 250 and an attachment mechanism 252. In a preferred embodiment, stopper element 250 is separate from attachment mechanism 252 and comprises, for example, spring wires, flexible polymers, or any other material which can be extended in a first configuration and which can be folded, sprung or otherwise positioned to act as a stopper in a second configuration. In an alternative embodiment, stopper element 250 is part of attachment mechanism 252, but can also be extended in a first configuration and positioned to act as a stopper in a second configuration. In one preferred embodiment, stopper element 250 is comprised of a shape memory metal such as, for example, Nitinol. In the embodiment described herein, spring wires are used as stopper element 250, which are designed to lay substantially horizontal to catheter 218 in their unextended positions and to coil or spring into a stopper upon release. Attachment mechanism 252 attaches the spring wires to main elongated element 216 to form crotch points 244. In a preferred embodiment, attachment mechanism 252 is a jacket having a proximal end 256 and a distal end 254. Attachment mechanism 252 at least partially encloses stopper element 250 (shown as spring wires), such that a proximal portion of stopper element 250 enclosed by attachment mechanism 252 is relatively straight, and a distal portion of stopper element 250 is unenclosed and able to move freely. Attachment mechanism 252 can comprise any biocompatible material, and is preferably comprised of a polymer. In a preferred embodiment, crotch points 244 are located at a proximal end of balloon 224.

[0083] Reference is now made to FIG. 14b, which is a cross-sectional view of system 210 along the lines A-A, in accordance with one embodiment. Catheter 218 has main guidewire lumen 227 for introduction of a main guidewire 239. Surrounding catheter 218 is stopper element 250, which is held in place by attachment mechanism 252.

[0084] Reference is now made to FIGS. 15a-b, which are illustrations of system 210 partially enclosed within a holder 254. The purpose of holder 254 is to temporarily hold stopper element 250 in a substantially straight configuration until the area of bifurcation point 3 is reached. In a preferred embodiment, holder 254 is a peel-away device. When holder 254 is in place, stopper element 250 is enclosed and lies approximately along the plane of main elongated element 216. In the embodiment shown in FIGS. 15a and b, stopper elements 250 are straightened in the distal direction, such that they run alongside stent 212. The area proximal to crotch points 244 is shown in cross section in FIG. 15b, and includes a main guidewire lumen 227 within catheter 218, stopper elements 250 enclosed within attachment mechanism 252, and holder 254 surrounding attachment mechanism 252.

[0085] Reference is now made to FIGS. 16a-b, which are illustrations of system 210 partially enclosed within holder 254, in accordance with another embodiment of the present invention. In the illustration shown in FIGS. 16a and b, stopper elements 250 are bent in a proximal direction, with holder 254 surrounding stopper elements 250 and holding them in place. That is, stopper elements 250 are folded over attachment mechanism 252. The area proximal to crotch points 244 is shown in cross section in FIG. 16b, and includes a main guidewire lumen 227 within catheter 218,

stopper elements 250 enclosed both within and outside of attachment mechanism 252, and holder 254 surrounding attachment mechanism 252 and stopper elements 250.

[0086] Reference is now made to FIG. 17, which is a depiction of system 210 within a guiding catheter 260. Guiding catheter 260 includes a proximal end 262, through which system 210 is introduced, and a distal end 264, which is open to a vessel. As system 210 is guided into proximal end 262 of guiding catheter 260, holder 254 is removed, since stopper element 250 will remain in place within guiding catheter 260. In a preferred embodiment, holder 254 is a peel-away system, wherein the outer walls may be peeled away and removed from the system while system 210 is being introduced into guiding catheter 260. This introduction is performed outside of the body. In an alternative embodiment, holder 254 is a sheath, which can be pulled back as system 210 is being introduced into guiding catheter 260. Holder 254 can be any device for holding stopper element 250 in place until system 210 is within guiding catheter 260.

[0087] Reference is now made to FIGS. 18a and 18b, which are depictions of a method for introducing system 210 to a bifurcation in accordance with an embodiment of the present invention. Guiding catheter 260 with system 210 positioned therein is introduced through main vessel 1 until bifurcation point 3. Distal end 264 of guiding catheter 260 is visualized using methods currently known in the art, such as, for example, fluorescent markers. Once distal end 264 of guiding catheter 260 is at the entrance to branch vessel 2, system 210 is advanced through distal end 264 of guiding catheter 260, as shown in FIG. 18a. As system 210 is advanced, stopper elements 250 are no longer held in place by guiding catheter 260, and will spring or coil into their second configuration, acting as stoppers, as shown in FIG. 18b. System 210 is then advanced until stopper elements 250 prevent system 210 from further advancement, as shown in FIG. 18c. At this point, system 210 is properly positioned, and stent 212 is deployed.

[0088] Bifurcation Type IV:

[0089] In a fourth embodiment, a stent delivery system 310 is designed to be delivered at a bifurcation 3 as illustrated in FIG. 19, having a Y-configuration. Main vessel 1 branches into two branch vessels: a first branch vessel 2 and a second branch vessel 2', and plaque 4 is located in main and or branch vessels at the area of bifurcation point 3.

[0090] Reference is now made to FIG. 20, which is an illustration of a stent delivery system 310, in accordance with one embodiment of the present invention. System 310 includes a main elongated element 316 and an auxiliary elongated element 334. In a preferred embodiment, main elongated element 316 is a catheter 318. Catheter 318 has a proximal end 322 and a distal end 320. Proximal end 322 includes a hub 321 having a Y-valve for dual inflation. Distal end 320 has two balloons: a proximal balloon 324 and a distal balloon 325. Each of proximal and distal balloons 324 and 325 is in fluid communication with its own inflation channel. An outer inflation channel 335 communicates with proximal balloon 324 and an inner inflation channel 327 communicates with distal balloon 325. Outer inflation channel 335 is coaxial with inner inflation channel 327. Alternatively, outer inflation channel 335 and inner inflation

channel **327** are positioned side by side. In either case, balloons **324** and **325** may be inflated separately. In an alternative embodiment, outer inflation channel communicates with distal balloon **325** and inner inflation channel **327** communicates with proximal balloon **324**. In a preferred embodiment, distal balloon **325** has a fixed wire **326** at a distal end thereof. In alternative embodiments, system **310** includes a main guidewire lumen or a short external guidewire lumen such as distal connecting element **50** shown in **FIG. 6**.

[**0091**] In a preferred embodiment, auxiliary elongated element **334** is a side branch lumen **336** having a proximal end **342** and a distal end **340**. In a preferred embodiment, side branch lumen **336** is located internally within catheter **318**, and exits therefrom at an exit point **337**. Distal to exit point **337**, side branch lumen **336** is adjacent to proximal balloon **324** and attached thereto at a crotch point **344**. In an alternative embodiment, side branch lumen **336** lies alongside proximal balloon **324**.

[**0092**] Reference is now made to **FIG. 21**, which is an illustration of system **310** with stents. In a preferred embodiment, two stents are included, as shown. A proximal stent **312** is positioned on proximal balloon **324**, and a distal stent **313** is positioned on distal balloon **325**. Each stent may be separately deployed by inflating its corresponding balloon. Proximal stent **312** is positioned such that distal end of side branch lumen **336** is approximately aligned with a distal end of proximal stent **312**. The distal edges of side branch lumen **336** and stent **312** form a crotch point **344**. In an alternative embodiment, side branch lumen **336** extends distally past crotch point **344**. All of the embodiments described earlier in the present application may further be applied here.

[**0093**] In alternative embodiments, system **310** includes one, two or no stents, depending on the application. For example, system **310** may be used for predilatation, with a stent only on proximal balloon **324**. Alternatively, a tapered vessel may require two different stent sizes, wherein one stent of a particular size is positioned on distal balloon **325**, while another stent of a different size is positioned on proximal balloon **324**.

[**0094**] Reference is now made to **FIGS. 22a-d**, which are illustrations of a method of deploying system **310** within a Y-bifurcation. First, a side branch guidewire **338** is introduced into a first branch vessel **2**. A proximal end of side branch guidewire **338** is then placed through a distal end of side branch lumen **336**. System **310** is advanced over side branch guidewire **38** through main vessel **1** and into second branch vessel **2'**. When crotch point **344** reaches bifurcation **3**, system **310** will not be advanceable, and system **310** will be in place, as shown in **FIG. 22a**. As shown in **FIG. 22b**, distal balloon **325** is inflated via inner inflation channel **327**, deploying distal stent **313** in a branch vessel, just distal to bifurcation point **3**. After deployment of distal stent **313**, proximal balloon **324** is inflated via outer inflation channel **335**, deploying proximal stent **312**. An alternate method is depicted in **FIG. 22c**, wherein proximal stent **312** is deployed first, and then distal stent **313** is deployed. In an alternative embodiment, both stents are deployed simultaneously. The final result with both stents deployed and in position is shown in **FIG. 22d**.

[**0095**] Reference is now made to **FIG. 23**, which is an illustration of a tapered balloon system **410**, in accordance

with an alternative embodiment of the present invention. Similar to the earlier embodiments, tapered balloon system **410** includes a main elongated portion and an auxiliary elongated element **434**. In a preferred embodiment, auxiliary elongated element **434** is a side branch lumen. A balloon has a proximal outer diameter and a distal outer diameter which is different from the proximal outer diameter. In a preferred embodiment, the distal outer diameter is smaller than the proximal outer diameter, although the reverse may be provided as well. This type of balloon system may be useful for introduction of a tapered stent into a vessel, so as to avoid over-expansion of a stent within a distal portion of the vessel.

[**0096**] Although the invention has been described in conjunction with specific embodiments thereof, it is evident that many alternatives, modifications and variations will be apparent to those skilled in the art. For example, a self-expandable stent may be used in place of a balloon expandable stent, in which case the catheter would not necessarily be a balloon catheter. Accordingly, it is intended to embrace all such alternatives, modifications and variations that fall within the spirit and broad scope of the appended claims. All publications, patents and patent applications mentioned in this specification are herein incorporated in their entirety by reference into the specification, to the same extent as if each individual publication, patent or patent application was specifically and individually indicated to be incorporated herein by reference. In addition, citation or identification of any reference in this application shall not be construed as an admission that such reference is available as prior art to the present invention.

What is claimed is:

1. A stent delivery system, the system comprising:
  - a main elongated element for advancement within a main vessel, said main elongated element comprising:
    - a proximal end;
    - a distal end; and
    - a body connecting said proximal and distal ends;
  - an auxiliary elongated element for advancement within an auxiliary vessel, said auxiliary elongated element comprising:
    - a proximal end; and
    - a distal end,
 said auxiliary elongated element partially attached to said main elongated element; and
- a crotch point, wherein at said crotch point, said body of said main elongated element is attached to said auxiliary elongated element, and wherein a location of said crotch point is configured to stop advancement of said system upon reaching a bifurcation.
2. The stent delivery system of claim 1, wherein said main elongated element is a catheter and said auxiliary elongated element is a side branch lumen.
3. The stent delivery system of claim 2, wherein said catheter includes a balloon.
4. The stent delivery system of claim 3, wherein said catheter is selected from the group consisting of a fixed wire balloon catheter, an over-the-wire catheter and a rapid exchange catheter.

5. The stent delivery system of claim 1, wherein said main elongated element is a catheter and said auxiliary elongated element is a positioning system.

6. The stent delivery system of claim 5, wherein said positioning system comprises at least one stopper and an attachment mechanism.

7. The stent delivery system of claim 6, wherein said at least one stopper is a spring wire.

8. The stent delivery system of claim 6, wherein said attachment mechanism is a polymer jacket, and wherein said polymer jacket is configured to hold a proximal portion of said at least one stopper in place, and wherein a distal end of said polymer jacket defines said crotch point.

9. The stent delivery system of claim 1, further comprising a stent with a side opening positioned on said main elongated element.

10. The stent delivery system of claim 9, wherein said side opening is a dedicated side opening.

11. The stent delivery system of claim 8, wherein said crotch point is located at a distal portion of said side opening of said stent.

12. The stent delivery system of claim 1, further comprising a stent having a proximal end and a distal end, said stent positioned on said main elongated element, and wherein said crotch point is located at said proximal end of said stent.

13. The stent delivery system of claim 1, further comprising a proximal stent comprising a proximal end and a distal end and a distal stent comprising a proximal end and a distal end, said proximal stent positioned on said main elongated element and said distal stent positioned distal to said proximal stent on said main elongated element.

14. The stent delivery system of claim 12, wherein said crotch point is located at said distal end of said proximal stent.

15. The stent delivery system of claim 1, wherein proximal to said crotch point, said bodies of said main and auxiliary elongated elements are attached.

16. The stent delivery system of claim 3, wherein said balloon is a tapered balloon.

17. The stent delivery system of claim 1, wherein said proximal end of said auxiliary elongated element is positioned within said main elongated element, and further comprising an exit point, wherein distal to said exit point said auxiliary elongated element is external to said main elongated element.

18. The stent delivery system of claim 1 wherein a distal end of said auxiliary elongated element is located distal to said crotch point, and wherein said distal end of said auxiliary elongated element is unattached to said main elongated element.

19. A stent delivery device, the device comprising:

a catheter having a distal end and a proximal end;

a balloon positioned on said catheter, the balloon having a distal end and a proximal end, wherein said balloon is immovable with respect to said catheter;

a wire attached to said distal end of said balloon; and

a side element having a distal end and a proximal end, said side element at least partially attached to said balloon.

20. The stent delivery device of claim 19, further comprising a stent with a side hole, said stent positioned on said balloon, said side hole having a distal end and a proximal

end, and wherein said proximal end of said side element is attached to said catheter and said distal end of said side element is positioned alongside said balloon, and wherein a crotch point is defined at a location wherein at said crotch point, said side element is attached to said balloon, and wherein said crotch point is located at said distal end of said side hole.

21. The stent delivery device of claim 20, wherein said side hole is a dedicated side hole.

22. The stent delivery device of claim 19, wherein said proximal end of said side branch lumen is positioned within said catheter.

23. The stent delivery device of claim 20, wherein said distal end of said side element is located distal to said crotch point, and wherein said distal end of said side element is unattached to said catheter.

24. The stent delivery device of claim 19, wherein said balloon is a tapered balloon.

25. The stent delivery device of claim 19, further comprising a stent positioned on said balloon, wherein said proximal end of said side element is attached to said catheter, and wherein a crotch point is defined at a location wherein at said crotch point, said side element is attached to said balloon, and wherein said crotch point is located at said proximal end of said balloon.

26. The stent delivery system of claim 25, wherein said distal end of said side element is located proximal to said crotch point, and wherein said distal end of said side element is unattached to said catheter.

27. The stent delivery system of claim 19, wherein said side element is a side branch lumen.

28. The stent delivery system of claim 19, wherein said side element is a stopper.

29. The stent delivery device of claim 19, wherein said balloon is a proximal balloon, and further comprising a distal balloon positioned on said catheter distal to said proximal balloon.

30. The stent delivery device of claim 29, wherein said distal balloon and said proximal balloon may be inflated separately.

31. The stent delivery device of claim 29, further comprising a distal stent positioned on said distal balloon, said distal stent having a proximal end and a distal end, and a proximal stent positioned on said proximal balloon, said proximal stent having a proximal end and a distal end.

32. The stent delivery device of claim 31, wherein said side element is at least partially attached to said proximal balloon.

33. The stent delivery device of claim 32, wherein a crotch point is defined at a location wherein at said crotch point, said side element is attached to said proximal balloon, and wherein said crotch point is located at a distal end of said proximal balloon.

34. The stent delivery device of claim 19, wherein an outer diameter of said system is less than 1 mm.

35. A stent delivery system, the system comprising:

a catheter having a distal end and a proximal end;

a balloon positioned on said catheter, the balloon having a distal end and a proximal end;

a wire attached to said distal end of said balloon;

- a side element having a distal end and a proximal end, said side element at least partially attached to said balloon; and
- a crotch point, wherein at said crotch point, said side element and said balloon are attached, and wherein a location of said crotch point is configured to stop advancement of said system upon reaching a bifurcation.
- 36.** The stent delivery system of claim 35, wherein said balloon is a tapered balloon.
- 37.** The stent delivery system of claim 35, wherein said catheter is selected from the group consisting of a fixed wire balloon catheter, an over-the-wire catheter and a rapid exchange catheter.
- 38.** The stent delivery system of claim 35, wherein said side element is a positioning system.
- 39.** The stent delivery system of claim 38, wherein said positioning system comprises at least one stopper and an attachment mechanism.
- 40.** The stent delivery system of claim 39, wherein said at least one stopper is a spring wire.
- 41.** The stent delivery system of claim 39, wherein said attachment mechanism is a polymer jacket, and wherein said polymer jacket is configured to hold a proximal portion of said at least one stopper in place, and wherein a distal end of said polymer jacket defines said crotch point.
- 42.** The stent delivery system of claim 35, further comprising a stent with a side opening positioned on said catheter.
- 43.** The stent delivery system of claim 42, wherein said side opening is a dedicated side opening.
- 44.** The stent delivery system of claim 42, wherein said crotch point is located at a distal portion of said side opening of said stent.
- 45.** The stent delivery system of claim 35, further comprising a stent having a proximal end and a distal end, said stent positioned on said catheter, and wherein said crotch point is located at said proximal end of said stent.
- 46.** The stent delivery system of claim 35, further comprising a proximal stent comprising a proximal end and a distal end and a distal stent comprising a proximal end and a distal end, said proximal stent positioned on said catheter and said distal stent positioned distal to said proximal stent on said catheter.
- 47.** The stent delivery system of claim 46, wherein said crotch point is located at said distal end of said proximal stent.
- 48.** The stent delivery system of claim 35, wherein proximal to said crotch point, said catheter and said side element are attached.
- 49.** The stent delivery system of claim 35, wherein said proximal end of said side element is positioned within said catheter.
- 50.** The stent delivery system of claim 35, wherein said distal end of said side element is located distal to said crotch point, and wherein said distal end of said side element is unattached to said catheter.
- 51.** The stent delivery system of claim 35, wherein said side element is a side branch lumen.
- 52.** The stent delivery system of claim 35, wherein said side element is a stopper.
- 53.** The stent delivery device of claim 35, wherein said balloon is a proximal balloon, and further comprising a distal balloon positioned on said catheter distal to said proximal balloon.
- 54.** The stent delivery device of claim 53, wherein said distal balloon and said proximal balloon may be inflated separately.
- 55.** The stent delivery system of claim 35, wherein an outer diameter of said system is less than 1 mm.
- 56.** A stent delivery system, the system comprising:
- a catheter having a distal end and a proximal end;
  - a balloon positioned on said distal end of said catheter, the balloon having a distal end and a proximal end, and wherein said balloon is immovable with respect to said catheter;
  - a stent positioned on said balloon, said stent having a side opening, wherein the side opening has a proximal end and a distal end; and
  - a side branch lumen having a distal end and a proximal end, wherein said proximal end is attached to a proximal end of said balloon, and wherein said distal end is positioned at said side opening of said stent.
- 57.** The stent delivery system of claim 56, wherein said balloon is a tapered balloon.
- 58.** The stent delivery system of claim 56, wherein said proximal end of said side branch lumen is positioned within said catheter, and wherein said distal end of said side branch lumen which is detached from said balloon is positioned outside of said catheter.
- 59.** The stent delivery system of claim 55, wherein said balloon comprises a fixed wire at a distal end thereof.
- 60.** The stent delivery system of claim 55, further comprising a distal connecting element at said distal end of said balloon.
- 61.** The stent delivery system of claim 60, wherein said distal connecting element lies on a same side of said catheter as said side branch lumen, and is configured for receiving a side branch guidewire, said side branch guidewire positionable through both said side branch lumen and said distal connecting element.
- 62.** The stent delivery system of claim 60, wherein said distal connecting element lies on an opposite side of said catheter as said side branch lumen, and is configured for receiving a main guidewire, said main guidewire positionable through said distal connecting element and outside of said stent.
- 63.** A stent delivery system, the system comprising:
- a catheter having a distal end and a proximal end;
  - a stent positioned on said catheter, the stent having a distal end and a proximal end;
  - an auxiliary elongated element having a distal end and a proximal end, said auxiliary elongated element positioned outside of said stent; and
  - a crotch point located at said proximal end of said stent wherein said auxiliary elongated element is attached to said catheter at said crotch point.
- 64.** The stent delivery system of claim 63, wherein said auxiliary elongated element is a side branch lumen.
- 65.** The stent delivery system of claim 63, further comprising a fixed wire balloon at said distal end of said catheter.

66. The stent delivery system of claim 63, further comprising a tapered balloon at said distal end of said catheter.

67. The stent delivery system of claim 63, wherein said auxiliary elongated element is a positioning system.

68. The stent delivery system of claim 67, wherein said positioning system comprises at least one stopper and an attachment mechanism.

69. The stent delivery system of claim 67, wherein said at least one stopper is a spring wire comprising a shape-memory metal.

70. The stent delivery system of claim 63, wherein said attachment mechanism is a jacket for holding a proximal end of said at least one spring wire in place.

71. The stent delivery system of claim 63, further comprising a holder for holding a distal end of said at least one spring wire in place.

72. A stent delivery system, the system comprising:

a catheter having a distal end and a proximal end;

a distal balloon positioned on said distal end of said catheter, the distal balloon having a distal end and a proximal end;

a proximal balloon positioned on said catheter proximal to said distal balloon;

a stent positioned on said proximal balloon, the stent having a distal end and a proximal end;

an auxiliary elongated element having a distal end and a proximal end, said auxiliary elongated element positioned inside of said stent and exiting at said distal end of said stent; and

a crotch point located at said distal end of said stent wherein said auxiliary elongated element is attached to said balloon at said crotch point.

73. The stent delivery system of claim 72, wherein said auxiliary elongated element is a side branch lumen.

74. The stent delivery system of claim 72, wherein said distal balloon has a fixed wire at said distal end of said distal balloon.

75. The stent delivery system of claim 72, further comprising a distal stent positioned on said distal balloon.

76. The stent delivery system of claim 72, wherein said stent and said distal stent separately deployable.

77. The stent delivery system of claim 72, wherein said distal stent has a smaller outer diameter than said proximal stent.

78. The stent delivery system of claim 72, wherein said proximal end of said auxiliary elongated element is positioned within said catheter.

79. The stent delivery system of claim 72, wherein said distal end of said auxiliary elongated element is located distal to said crotch point and wherein said distal end of said auxiliary elongated element is unattached to said catheter.

80. A catheter system comprising:

a catheter having a distal end, a proximal end and a body connecting said distal and proximal ends;

a side branch lumen having a distal end, a proximal end and a body connecting said distal and proximal ends, wherein a first portion of said side branch lumen is positioned inside said body of said catheter, and a second portion of said side branch lumen is positioned outside said body of said catheter; and

an exit point located on said body of said catheter wherein said first portion is proximal to said exit point and said second portion is distal to said exit point.

81. The catheter system of claim 80, further comprising a crotch point, wherein at said crotch point said side branch lumen is attached to said catheter, and wherein said crotch point is located on said second portion of said side branch lumen.

82. The catheter system of claim 81, wherein said crotch point is located at said distal end of said side branch lumen.

83. The catheter system of claim 81, wherein said crotch point is located proximal to said distal end of said side branch lumen.

84. The catheter system of claim 80, further comprising a balloon on said distal end of said catheter.

85. The catheter system of claim 84, wherein said balloon is a fixed wire balloon.

86. The catheter system of claim 84, wherein said balloon is a tapered balloon.

87. A method for treating a bifurcation, the method comprising:

introducing a side branch guidewire into a branch vessel; providing a stent delivery system, wherein the system comprises:

a main elongated element for advancement within a main vessel, said main elongated element having a proximal end, a distal end, and a body connecting said proximal and distal ends;

a side branch element for advancement within said side branch vessel, said side branch element having a body which is partially attached to said main elongated element;

a crotch point, wherein at said crotch point, said bodies of said main and side branch elements are attached, and wherein a location of said crotch point is configured to stop advancement of said system at a bifurcation; and

a stent positioned on said main elongated element;

inserting a proximal end of said side branch guidewire into said distal end of said side branch lumen;

advancing said stent delivery system over said side branch guidewire until a location at which said advancing automatically stops due to said crotch point reaching said bifurcation; and

deploying said stent.

88. A method for treating a bifurcation, the method comprising:

providing a stent delivery system, wherein the system comprises: a catheter having a balloon at a distal end thereof; a fixed wire at a distal end of said balloon; and a side branch lumen at least partially attached to said catheter, wherein a point of attachment defines a stopping point; and

advancing said stent delivery system through a main vessel until a location at which said advancing automatically stops due to said crotch point reaching said bifurcation.