



US 20050250619A1

(19) **United States**

(12) **Patent Application Publication**
Daikeler et al.

(10) **Pub. No.: US 2005/0250619 A1**

(43) **Pub. Date: Nov. 10, 2005**

(54) **DOORWAY MOUNTED EXERCISE APPARATUS**

(52) **U.S. Cl. 482/40; 482/37**

(76) **Inventors: Carl Daikeler, Malibu, CA (US); Jonathan Congdon, Pacific Palisades, CA (US); Steve Edwards, Culver City, CA (US); Leigh Miller, Los Angeles, CA (US); Tony Horton, Santa Monica, CA (US)**

(57) **ABSTRACT**

An exercise apparatus that is to be mounted in a doorway and held in position by the user's own body weight during use. In one aspect the invention comprises: first and second L-shaped members disposed in side-by-side relation, each having a horizontal section and a vertical section; a first member having a length less than a width of the doorway and connected to the vertical sections of the first and second L-shaped members; a second member having a length greater than the width of the doorway and connected to the horizontal sections of the first and second L-shaped members at a first horizontal distance from the first member; a first gripping bar connected to the horizontal section of the first L-shaped member at a second horizontal distance from the first member, the second horizontal distance being greater than the first horizontal distance; and a second gripping bar connected to the horizontal section of the second L-shaped member at approximately the second horizontal distance.

Correspondence Address:
COZEN O'CONNOR, P.C.
1900 MARKET STREET
PHILADELPHIA, PA 19103-3508 (US)

(21) **Appl. No.: 10/841,759**

(22) **Filed: May 7, 2004**

Publication Classification

(51) **Int. Cl.⁷ A63B 7/04; A63B 9/00**

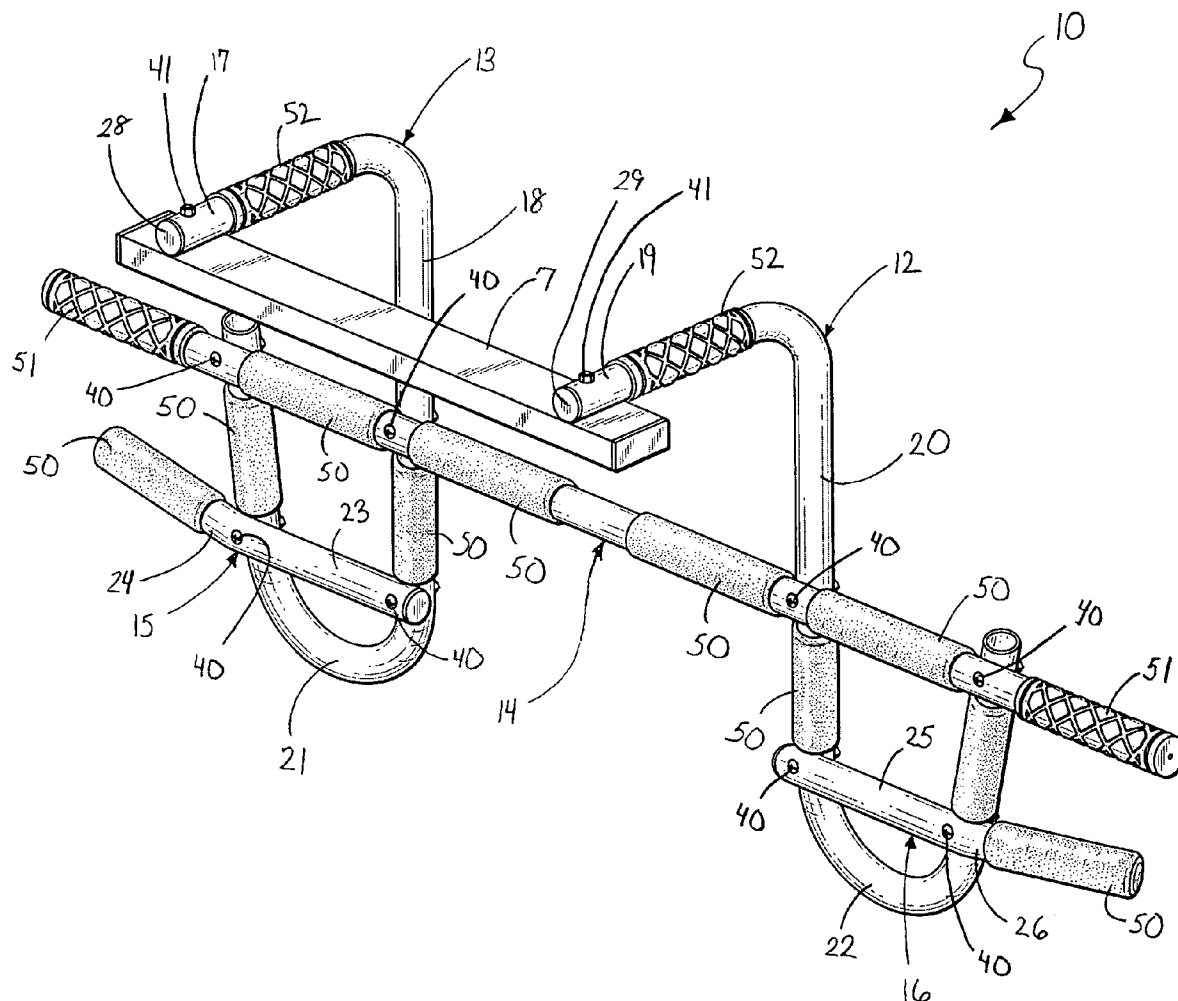

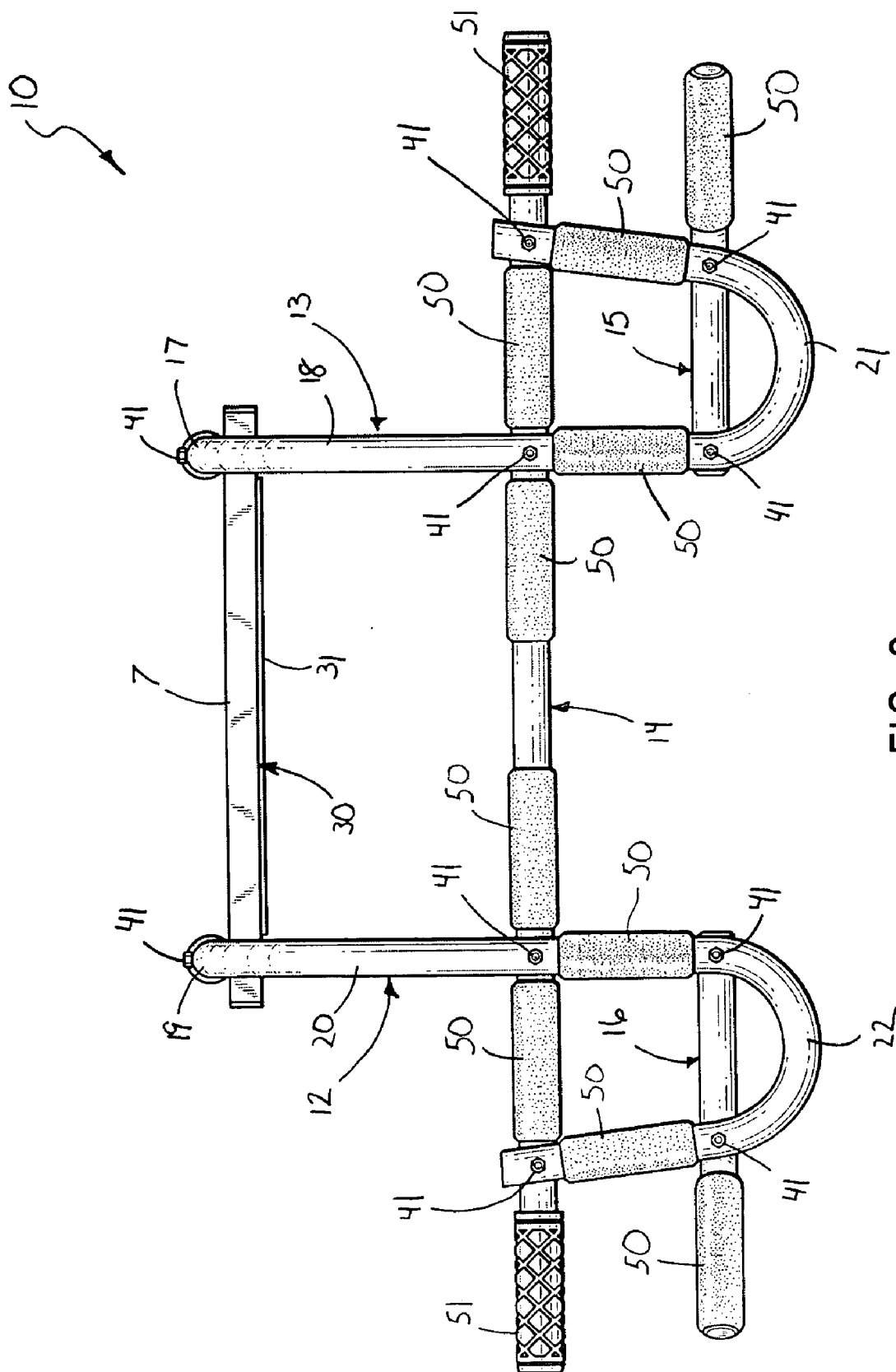

FIG. 3

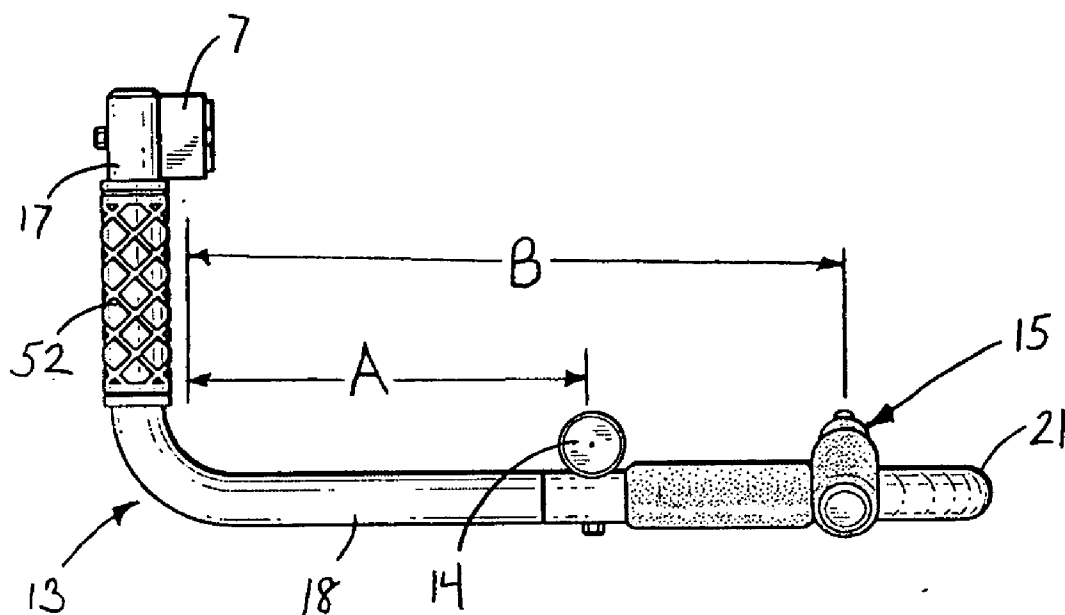

FIG. 4

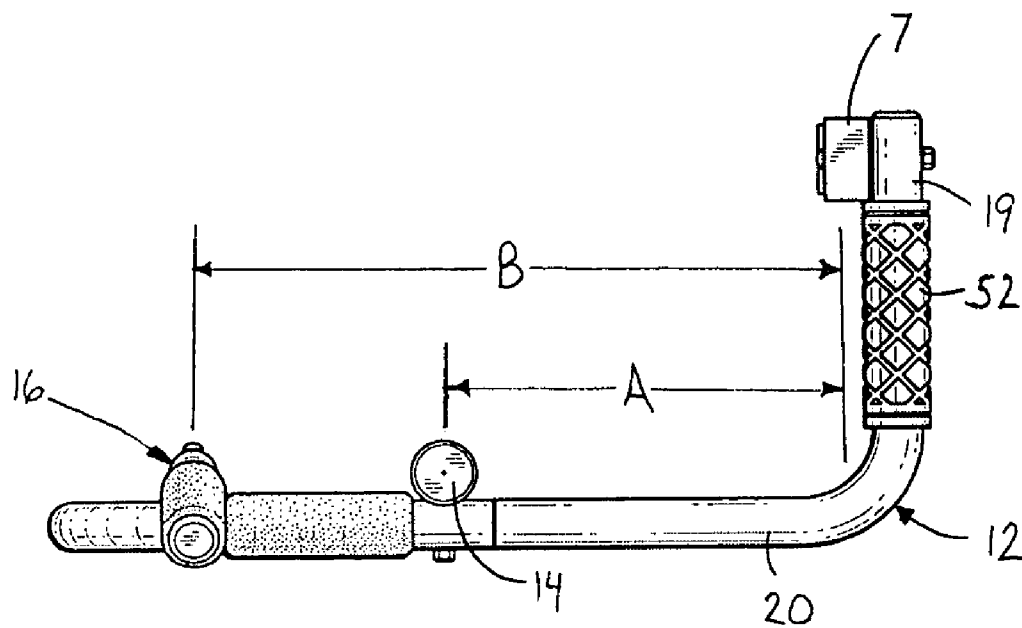

FIG. 5

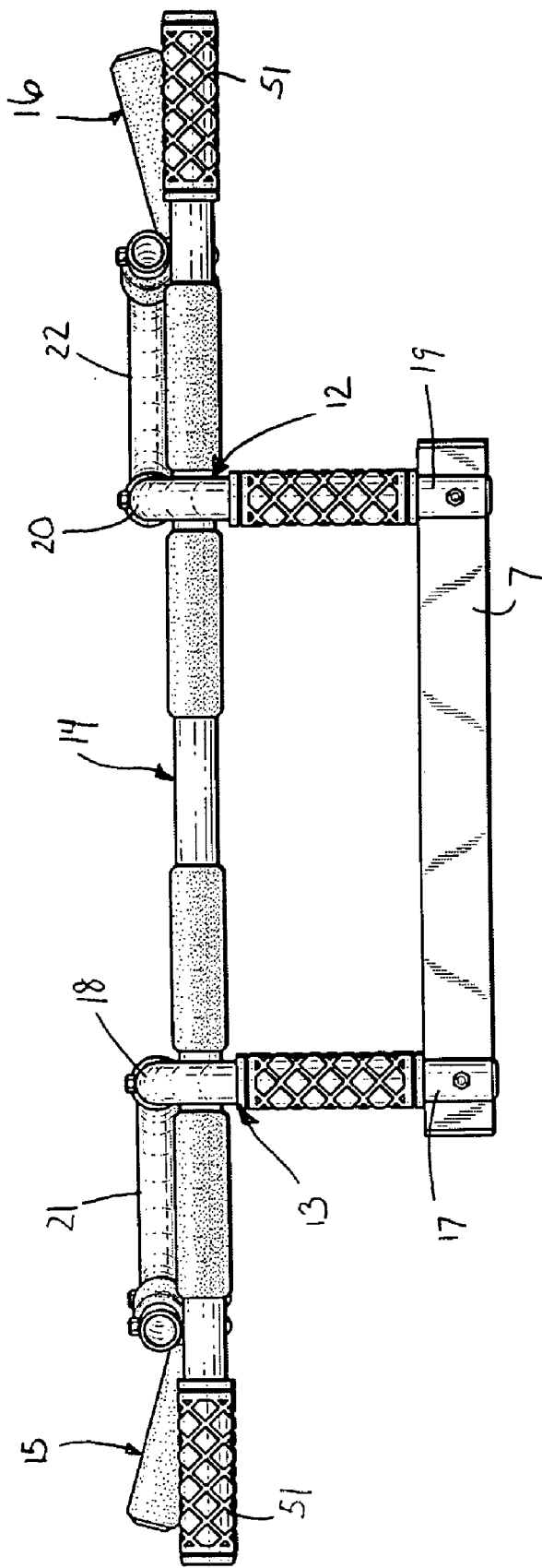

FIG. 6

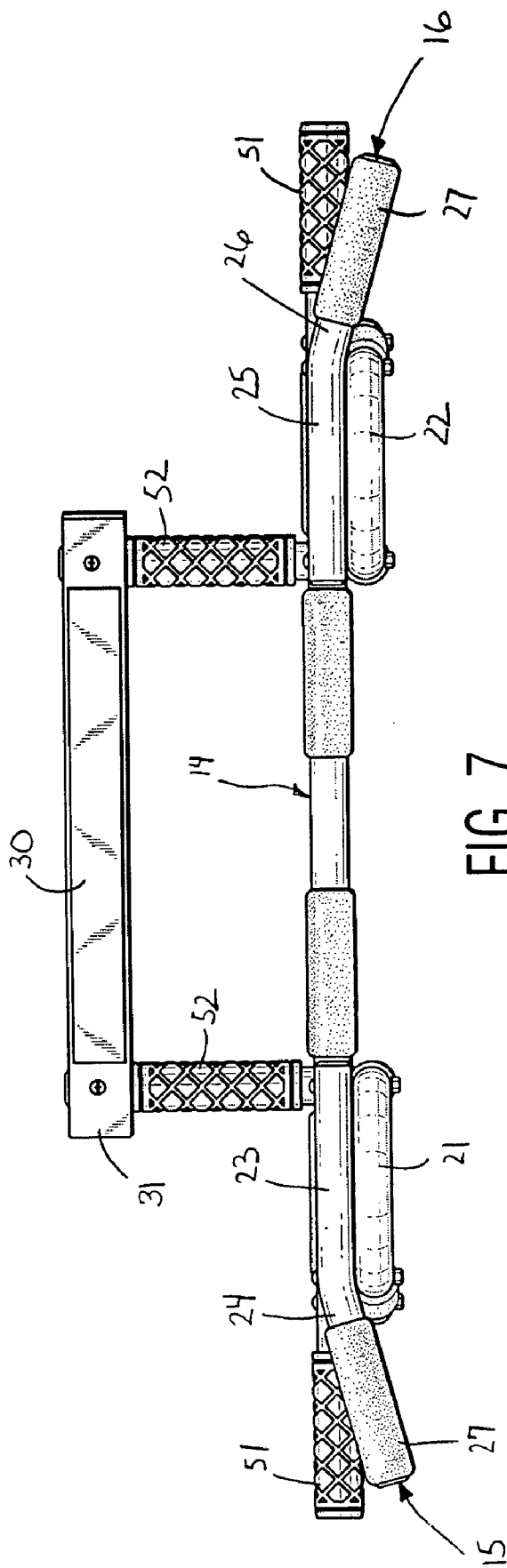

FIG. 7

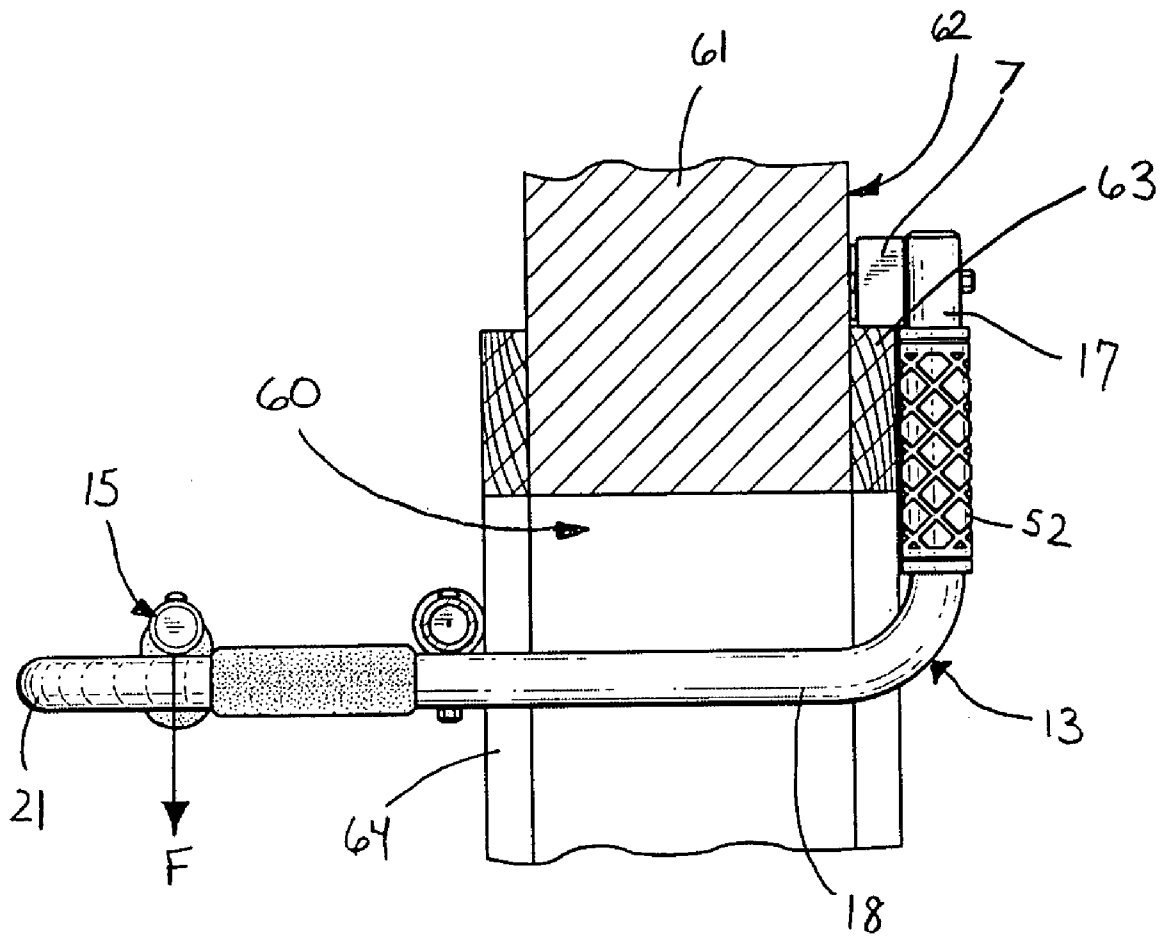

FIG. 8

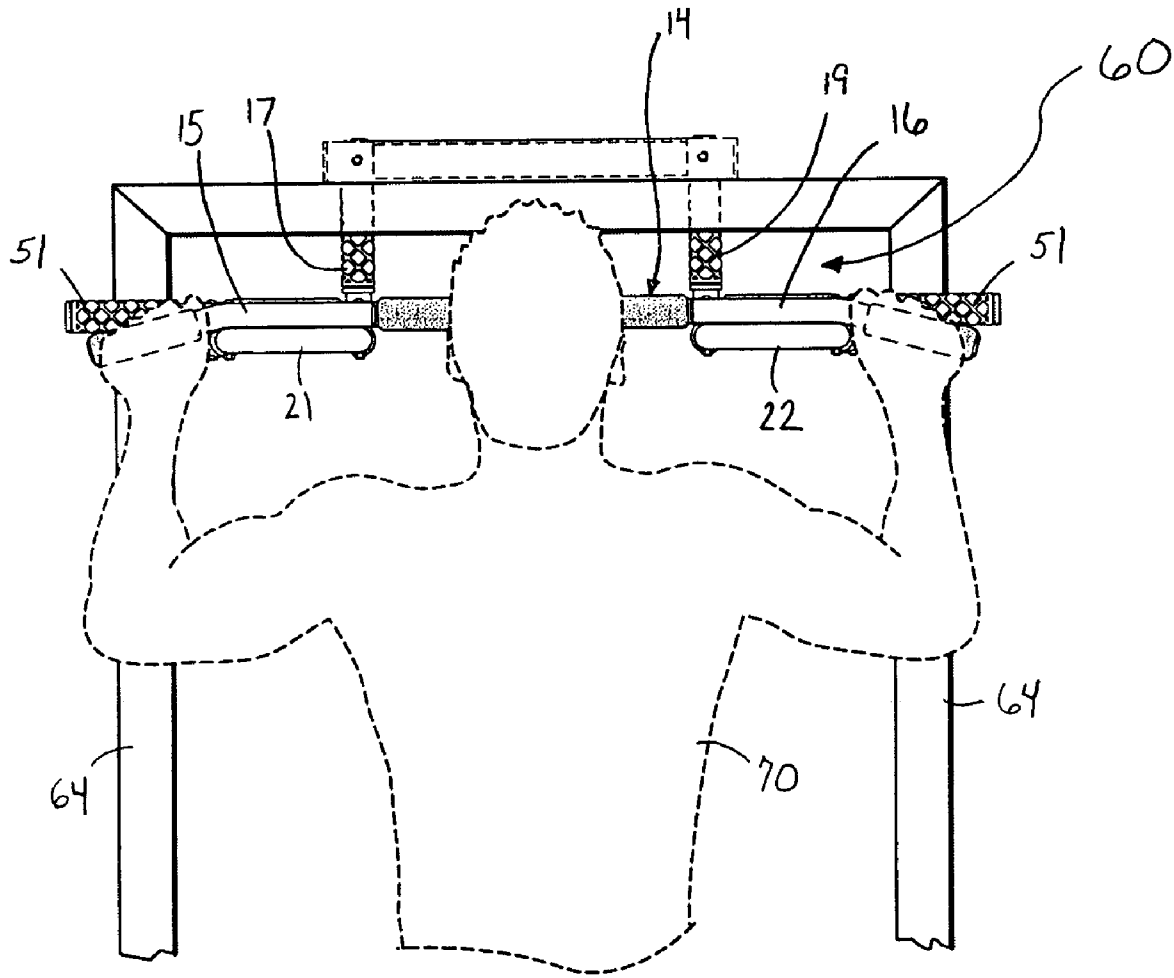

FIG. 9

DOORWAY MOUNTED EXERCISE APPARATUS**FIELD OF THE INVENTION**

[0001] The present invention relates generally to exercise apparatus and equipment, and specifically to exercise equipment that is mounted in a doorway for performing chin-ups.

BACKGROUND OF THE INVENTION

[0002] As society continues to realize the importance of daily exercise in order to remain healthy, the need for improved and widely accessible exercise equipment continues to grow. Because of the large number of muscles (and different muscle groups) that are worked in performing chin-ups, chin-ups have long been realized as a valuable exercise in maintaining and developing muscle strength, reducing body fat, and shaping the body. However, performing chin-ups often requires sizable exercise structures that take up a significant amount of space. Most gyms and fitness clubs provide free-standing exercise structures having the necessary bar(s) from which a user can hang to perform the desired exercise.

[0003] However, because people live such busy lifestyles, many people do not have the time or can not afford to attend gyms or fitness clubs on a regular basis. Thus, a need exists for exercise equipment that allows a user to perform chin-ups in the convenience of their own home that is compact, easy to use, and cost efficient.

[0004] While exercise apparatus have been developed to afford user's the ability to perform chin-ups in the home, existing apparatus are less than optimal in that they are difficult to install, bulky, expensive to manufacture, or do not afford user flexibility in gripping positions which prohibits concentrating on specific muscles. One such existing device is disclosed in U.S. Pat. No. 3,915,452, Winblad. However, the exercise device of Winblad suffers from a number of the aforementioned deficiencies. Specifically, because the first and second horizontal members of the Winblad device are equal in size, the first horizontal member that contacts the rear surface of the wall above the doorway is at least greater than the width of the doorway. This results in the Winblad device being difficult for a user to install in a doorway for use. Additionally, because the chinning bar of the Winblad device extends between the L-shaped members, the length of the chinning bar is limited to a length less than the width of the doorway, prohibiting user's from varying their gripping position to a wide grip so that pull-ups can be performed comfortably. Additionally, the Winblad device is bulky and can be difficult/expensive to manufacture.

[0005] Another existing exercise device for performing chin-ups in the home is disclosed in U.S. Design Pat. No. 348,706, Harrell. However, the design of the Harrell device is less than optimal in that it limits a user in his/her choice of gripping positions and width of grip. Because the chinning bar of the Harrell device is the same horizontal member that contacts the sides of the door frame for support, the user is limited to a gripping position that is less than the width of the doorway and within the L-shaped members. Moreover, using the horizontal member as the chinning bar also forces the user to be very close to the planar surface of the wall and to hang within the doorway itself during use. This prohibits the user from performing a natural chin-up motion because the surface of the wall above the doorway can obstruct the user's natural motion.

DISCLOSURE OF THE INVENTION

[0006] It is therefore an object of the present invention is to provide an exercise apparatus that allows a user to exercise in their home.

[0007] Another object of the present invention is to provide an exercise apparatus that allows a user to perform chin-ups.

[0008] Yet another object of the present invention is to provide an exercise apparatus that allows a user to perform chin-ups that is easy to install in a doorway.

[0009] Still another object of the present invention is to provide an exercise apparatus that allows a user to perform chin-ups using a variety of gripping positions.

[0010] A still further object of the present invention is to provide an exercise apparatus that allows a user to perform chin-ups that is easy and/or cost effective to manufacture.

[0011] A further object of the present invention is to provide an exercise apparatus that allows a user to perform chin-ups in a doorway of home without the chin-up motion being obstructed by the door frame or wall.

[0012] These and other objects are met by the present invention which in one aspect is an exercise apparatus for use in a doorway, the exercise apparatus comprising: first and second L-shaped members disposed in side-by-side relation, each of the first and second L-shaped members having a horizontal section and a vertical section; a first member having a length less than a width of the doorway and connected to the vertical sections of the first and second L-shaped members; a second member having a length greater than the width of the doorway and connected to the horizontal sections of the first and second L-shaped members a first horizontal distance from the first member; a first gripping bar connected to the horizontal section of the first L-shaped member at a second horizontal distance from the first member, the second horizontal distance being greater than the first horizontal distance; and a second gripping bar connected to the horizontal section of the second L-shaped member at approximately the second horizontal distance. For ease of installation in a doorway, the first horizontal distance is preferably at least greater than a thickness of the wall through which the doorway passes.

[0013] When being installed in a doorway for use, the user positions the exercise apparatus so that the first member of the exercise apparatus passes through the doorway and contacts the opposite side of the wall above the doorway. The vertical sections of the L-shaped members are connected to the first member and extend downward therefrom so that the horizontal sections extend through the doorway so that the second member and the first and second gripping bars are on the side of the doorway where the user is located. The exercise apparatus is rotated, keeping the first member in contact with the opposing side of the wall above the doorway until the second member contacts the sides of the doorway (or the wall forming the doorway) on the same side of the wall where the user is located. Because the first and second gripping bars are located on the horizontal sections of the L-shaped member at a greater horizontal distance from the first member than is the second member, the first and second gripping bars are spaced apart from the wall and the plane of the doorway. The user can then hold the

gripping bars and hang therefrom. The downward force exerted on the gripping bars by the user's weight causes a moment to be exerted, causing the second member to be pressed against the sides of the doorway and the first member to be pressed against the opposing surface of the wall atop of the doorway. Thus, the user's own weight holds the exercise apparatus securely in place in the doorway.

[0014] It is preferred that the first member be substantially parallel to the second member and comprise a substantially planar surface. A friction strip can be placed on the substantially planar surface for increasing the coefficient of friction that is formed between the opposing surface of the wall above the doorway and the first member. The friction strip can be made of hard rubber or soft rubber.

[0015] The horizontal section of each of the first and second L-shaped members preferably comprises a U-shaped portion. In this embodiment, the second member will be positioned atop and secured to both legs of each U-shaped portion of the first and second L-shaped members. This results in a total of four connection points. It is also preferred that the first gripping bar be connected to both legs of the U-shaped portion of the first L-shaped member and that the second gripping bar be connected to both legs of the U-shaped portion of the second L-shaped member. Connecting each of the first and second gripping bars at two positions on the U-shaped portions provides structural integrity and stability. A hand grip can be provided on each leg of the two U-shaped portions. This affords a variety of gripping positions and widths for the user.

[0016] The first gripping bar and second gripping bar can be angled in shape so that each comprises a horizontal section and a section that is vertically angled downward. A hand grip can be provided on each of the first and second gripping bars, preferably on the sections that are vertically angled downward. All hand grips can be made of foam or other suitable material for gripping.

[0017] The second member preferably has a circular cross sectional profile and a plurality of hand grips located thereon so that the user can grip the second bar if he/she so pleases. Friction sleeves can be provided on the ends of the second member for increasing a coefficient of friction between the wall and the second member. These friction sleeves can be made of hard or soft rubber.

[0018] In another aspect, the invention is an exercise system comprising: a wall having a first surface and an opposing surface forming a thickness; a doorway extending through the thickness of the wall from the one surface to the opposing surface, the doorway having a width, sides, and a top; a first member having a length less than the width of the doorway and in contact with the top of the doorway on the first surface of the wall; first and second L-shaped members disposed in side-by-side relation, each of the first and second L-shaped members having a horizontal section and a vertical section, the first member connected to the vertical sections of the first and second L-shaped members so that the horizontal sections extend through the doorway; a second member having a length greater than the width of the doorway, the second member connected to the horizontal sections of the first and second L-shaped members so that the second member is in contact with the sides of the doorway on the opposing surface of the wall; a first gripping bar connected to the horizontal section of the first L-shaped

member at a horizontal distance away from the opposing surface of the wall; and a second gripping bar connected to the horizontal section of the second L-shaped member at substantially the horizontal distance.

BRIEF DESCRIPTION OF THE DRAWINGS

[0019] FIG. 1 is a perspective view of an exercise apparatus according to an embodiment of the present invention.

[0020] FIG. 2 is a top view of the exercise apparatus of FIG. 1.

[0021] FIG. 3 is a bottom view of the exercise apparatus of FIG. 1.

[0022] FIG. 4 is a left side view of the exercise apparatus of FIG. 1.

[0023] FIG. 5 is a right side view of the exercise apparatus of FIG. 1.

[0024] FIG. 6 is a rear view of the of the exercise apparatus of FIG. 1.

[0025] FIG. 7 is a top view of the exercise apparatus of FIG. 1.

[0026] FIG. 8 is a cross sectional view of the exercise apparatus of FIG. 1 positioned in a doorway for use.

[0027] FIG. 9 is a front view of a user performing chin-ups using the exercise apparatus of FIG. 1 positioned in a doorway.

MODES FOR CARRYING OUT THE INVENTION

[0028] Referring to FIG. 1, chin-up apparatus 10 is illustrated according to an embodiment of the present invention. Chin-up apparatus 10 comprises plate member 7, left L-shaped member 12, right L-shaped member 13, support member 14, left gripping bar 15, and right gripping bar 16. Left and right L-shaped members 12, 13 are disposed in side-by-side relation and are substantially parallel to one another. Plate member 7 and support member 14 are connected to L-shaped members 12, 13 so that they are substantially parallel to one another and perpendicular to L-shaped member 12, 13.

[0029] Left-L-shaped member 10 comprises vertical section 17 and horizontal section 18. Right-L-shaped member 12 comprises vertical section 19 and horizontal section 20. Horizontal sections 18, 20 respectively comprise U-shaped portions 21, 22. Vertical sections 17, 19 connect to horizontal sections 18, 20 respectively to form L-shaped members 12, 13 at an approximately 90 degree angle (best shown in FIGS. 4 and 5). However, the L-shaped members are not limited to this angle.

[0030] Referring to FIG. 2, a top view of chin-up apparatus 10 is illustrated. Plate member 7 extends a length that is less than the width of the doorway in which chin-up apparatus 10 is to be used. This allows easy installation of chin-up apparatus 10 for use. Plate member 7 is secured to vertical sections 17, 19 of L-shaped member 12, 13 at or near the top 28, 29 of the vertical sections 17, 19. Plate member 7 is secured to vertical sections 17, 19 of L-shaped members 12, 13 via bolts 40 that extend through aligned holes in plate member 7 and vertical sections 17, 19. Bolts 40 threadly engage nuts 41 providing adequate stability.

[0031] Plate member 7 is a rectangular box shape having planar surface 30 for contacting a wall during use. Strip 31 (best illustrated in FIG. 7) is provided on the substantially planar surface 30 of plate member 7 for increasing the coefficient of friction between the wall of contact and the plate member 7. Plate member 7 is made of hard plastic but can be constructed of a variety of materials including steel, iron, or other suitably rigid materials. Strip 31 can be made of hard or soft rubber and can be secured to plane surface 30 of plate member 7 with a suitable adhesive. Strip 31 is preferably of sufficient thickness that the heads of bolts 40 do not contact the wall during use. This prevents the wall from being damaged during use.

[0032] Support member 14 has a length that is greater than the width of the doorway chin-up apparatus 10 is to be used in. Support member 14 is secured atop horizontal sections 18, 20 of L-shaped members 12, 13 via bolts 40 that extend through aligned holes in support member 14 and horizontal sections 18, 20. Support member 14 is secured to each of L-shaped member 12, 13 at two locations. Specifically, support member 14 is secured to each leg of U-shaped portions 21, 22 of horizontal sections 18, 20 via bolts 40 that threadily engage corresponding nuts 41 (FIG. 3) on the bottom of chin-up apparatus 10. A total of four connection points is used.

[0033] Similarly, left gripping bar 15 and right gripping bar 16 are respectively secured atop U-shaped portions 21, 22 of horizontal sections 18, 20 of L-shaped members 13, 12. Left gripping bar 15 is secured to each leg of U-shaped portion 21 via bolts 40 that extend through aligned holes and threadily engage nuts 41 (FIG. 3). Right gripping bar 16 is secured to each leg of U-shaped portion 22 via bolts 40 that extend through aligned holes and threadily engage nuts 41 (FIG. 3).

[0034] As best illustrated in FIG. 7, left gripping bar 15 comprises horizontal section 23 and an angled section 24. Angled section 24 is vertically angled downward. Right gripping bar 16 comprises horizontal section 25 and angled section 26. Angled section 26 is vertically angled downward.

[0035] Referring back to FIG. 2, a plurality of hand grips 50 are provided on chin-up apparatus 10 so that the user can grip chin-up apparatus 10 in a variety of positions during use. Hand grips 50 are sleeves that fit over the tubular members of chin-up apparatus 10 and can be made of foam. A total of four hand grips 50 are provided on support member 14. Specifically, a hand grip 50 is provided on support member 14 between where each of the legs of U-shaped portions 21, 22 connect to support member 14. A pair of hand grips 50 is also provided on support member 14 between the L-shaped members 12, 13. Hand grips 50 are also provided on each of the legs of U-shaped portions 21, 22 of horizontal sections 18, 20 of L-shaped members 12, 13 between support member 14 and gripping bars 15, 16. A hand grip 50 is also provided on each of angled sections 24, 26 of gripping bars 15, 16.

[0036] End sleeves 51 are provided to cover the ends of support member 14 for increasing the coefficient of friction between the wall (or sides of the doorway) and support member 14 during use. End sleeves 51 also protect the wall (or sides of the doorway) from being damaged during use. End sleeves 51 are preferably constructed of hard or soft rubber. Sleeves 52 are also provided on vertical sections 17, 19 of L-shaped members 12, 13. Sleeves 52 are preferably constructed of hard or soft rubber.

[0037] Referring now to FIGS. 4 and 5, support member 14 is secured atop horizontal sections 18, 20 of L-shaped

member 12, 13 at a horizontal distance A from plate member 7. Horizontal distance A is preferably equal to or larger than the thickness of the doorway in which chin-up apparatus 10 is to be used. Gripping bars 15, 16 are respectively secured atop horizontal sections 18, 20 of L-shaped member 13, 12 at horizontal distance B from plate member 7. Horizontal distance B is larger than horizontal A. Gripping bars 15, 16 are substantially aligned with each other. In an alternative embodiment, gripping bars 15, 16 can be constructed to be a single bar.

[0038] Referring to FIGS. 8 and 9, chin-up apparatus 10 is illustrated installed in doorway 60 that extends through wall 61 for use by person 70. When chin-up apparatus 10 is installed in doorway 60 for use, plate member 7 contacts the opposing surface 62 of the wall 61 above the doorway 60. More specifically, it is preferred that strip 31 on planar surface 30 (FIG. 7) of plate member 7 contact opposing surface 62 of wall 61 at a position above top piece 63 of the doorway frame. When so positioned, vertical sections 17, 19 of L-shaped members 12, 13 extend downward on the opposing side of doorway 60. Horizontal sections 18, 20 of L-shaped member 12, 13 extend through doorway 60. Because the length of support member 14 is greater than the width of doorway 60, the ends of support member 14 contact the sides 64 of the doorway frame. Specifically, end sleeves 51 contact sides 64 of the doorway frame. Because gripping bars 15, 16 are spaced at a greater horizontal distance from plate member 17 than is support member 14, gripping bars 15, 16 are spaced from the planar surface of the wall and the doorway 60.

[0039] When a person 70 grips gripping bars 15, 16 to perform chin-ups, a downward force F is exerted. This downward force F causes a moment about the doorway frame, thereby pressing support member 14 against the sides 64 of the doorway frame while pressing plate member 7 against opposing surface 62 of wall 61 above doorway 60. As such, the weight of person 70 holds chin-up apparatus 10 in position during use.

[0040] Preferably, support member 14, L-shaped member 12, 13, and gripping bars 15, 16 are made of one inch steel tubing that is bent to the appropriate shape. As such, support member 14, L-shaped member 15, 16, and gripping bars 15, 16 will have circular cross sectional shapes.

[0041] While the invention has been described and illustrated in sufficient detail that those skilled in this art can readily make and use it, various alternatives, modifications, and improvements should become readily apparent without departing from the spirit and scope of the invention.

What is claimed is:

1. An exercise apparatus for use in a doorway through a wall, the exercise apparatus comprising:

first and second L-shaped members disposed in side-by-side relation, each of the first and second L-shaped members having a horizontal section and a vertical section;

a first member having a length less than a width of the doorway and connected to the vertical sections of the first and second L-shaped members;

a second member having a length greater than the width of the doorway and connected to the horizontal sections of the first and second L-shaped members at a first horizontal distance from the first member;

- a first gripping bar connected to the horizontal section of the first L-shaped member at a second horizontal distance from the first member, the second horizontal distance being greater than the first horizontal distance; and
- a second gripping bar connected to the horizontal section of the second L-shaped member at approximately the second horizontal distance.
- 2. The exercise apparatus of claim 1 wherein the first member is substantially parallel to the second member.
- 3. The exercise apparatus of claim 1 wherein the first member comprises a substantially planar surface.
- 4. The exercise apparatus of claim 3 further comprising a friction strip on the substantially planar surface for increasing a coefficient of friction between the wall and the first member.
- 5. The exercise apparatus of claim 4 wherein the friction strip is comprises hard rubber or soft rubber.
- 6. The exercise apparatus of claim 1 wherein the horizontal section of each of the first and second L-shaped members comprises a U-shaped portion.
- 7. The exercise apparatus of claim 6 wherein the second member connects to both legs of each U-shaped portion of the first and second L-shaped members.
- 8. The exercise apparatus of claim 7 wherein the first gripping bar connects to both legs of the U-shaped portion of the first L-shaped member and the second gripping bar connects to both legs of the U-shaped portion of the second L-shaped member.
- 9. The exercise apparatus of claim 6 further comprising a hand grip on each leg of each U-shaped portion of the first and second L-shaped members.
- 10. The exercise apparatus of claim 9 wherein the hand grips are made of foam.
- 11. The exercise apparatus of claim 1 wherein the first gripping bar and second gripping bar comprise a horizontal section and a section that is vertically angled downward.
- 12. The exercise apparatus of claim 1 wherein the second member has a circular cross sectional profile.
- 13. The exercise apparatus of claim 12 further comprising a plurality of hand grips on the second member.
- 14. The exercise apparatus of claim 1 comprising friction sleeves covering ends of the second member for increasing a coefficient of friction between the wall and the second member.
- 15. The exercise apparatus of claim 14 wherein the friction sleeves are made of hard or soft rubber.
- 16. The exercise apparatus of claim 1 further comprising a hand grip on each of the first and second gripping bars.
- 17. The exercise apparatus of claim 1 wherein the second member, the first gripping bar, and the second gripping bar are connected atop the horizontal sections of the first and second L-shaped members.
- 18. The exercise apparatus of claim 1 wherein the first horizontal distance is at least greater than a thickness of the wall.
- 19. The exercise apparatus of claim 1 further comprising:
 - the first member having a substantially planar surface;
 - a friction strip on the substantially planar surface of the first member for increasing a coefficient of friction between the wall and the first member;

- the horizontal sections of each of the first and second L-shaped members having a U-shaped portion;
- the second member connecting to both legs of each U-shaped portion of the first and second L-shaped members;
- the first gripping bar connecting to both legs of the U-shaped portion of the first L-shaped member and the second gripping bar connects to both legs of the U-shaped portion of the second L-shaped member;
- the first gripping bar and second gripping bar each comprising a horizontal section and a section that is vertically angled downward;
- the second member having a circular cross sectional profile and ends;
- friction sleeves covering the ends of the second member for increasing a coefficient of friction between the wall and the second member;
- hand grips on each leg of the U-shaped portions, on the second member; and on each of the first and second gripping bars;
- the second member, the first gripping bar, and the second gripping bar being atop the horizontal sections of the first and second L-shaped members; and
- the first horizontal distance being at least greater than a thickness of the wall
- 20. An exercise system comprising:
 - a wall having a first surface and an opposing surface forming a thickness;
 - a doorway extending through the thickness of the wall from the one surface to the opposing surface, the doorway having a width, sides, and a top;
 - a first member having a length less than the width of the doorway and in contact with the top of the doorway on the first surface of the wall;
 - first and second L-shaped members disposed in side-by-side relation, each of the first and second L-shaped members having a horizontal section and a vertical section, the first member connected to the vertical sections of the first and second L-shaped members so that the horizontal sections extend through the doorway;
 - a second member having a length greater than the width of the doorway, the second member connected to the horizontal sections of the first and second L-shaped members so that the second member is in contact with the sides of the doorway on the opposing surface of the wall;
 - a first gripping bar connected to the horizontal section of the first L-shaped member at a horizontal distance away from the opposing surface of the wall; and
 - a second gripping bar connected to the horizontal section of the second L-shaped member at substantially the horizontal distance.

* * * * *