



(19) **United States**

(12) **Patent Application Publication**  
**Moon et al.**

(10) **Pub. No.: US 2008/0085565 A1**

(43) **Pub. Date: Apr. 10, 2008**

(54) **METHOD OF READING ENCODED PARTICLES**

(52) **U.S. Cl. .... 436/164**

(75) **Inventors: John A. Moon**, Wallingford, CT (US); **Martin A. Putnam**, Cheshire, CT (US)

(57) **ABSTRACT**

Correspondence Address:  
**THE SMALL PATENT LAW GROUP LLP**  
**611 OLIVE STREET, SUITE1611**  
**ST. LOUIS, MO 63101**

Microparticles **8** includes an optical substrate **10** having at least one diffraction grating **12** disposed therein. The grating **12** having a plurality of collocated pitches  $\Lambda$  which represent a unique identification digital code that is detected when illuminated by incident light **24**. The incident light **24** may be directed transversely from the side of the substrate **10** with a narrow band (single wavelength) or multiple wavelength source, in which case the code is represented by a spatial distribution of light or a wavelength spectrum, respectively. The code may be digital binary or may be other numerical bases. The micro-particles **8** can provide a large number of unique codes, e.g., greater than 67 million codes, and can withstand harsh environments. The micro-particles **8** are functionalized by coating them with a material/substance of interest, which are then used to perform multiplexed experiments involving chemical processes, e.g., DNA testing and combinatorial chemistry.

(73) **Assignee: CyVera Corporation**

(21) **Appl. No.: 11/544,309**

(22) **Filed: Oct. 6, 2006**

**Publication Classification**

(51) **Int. Cl. G01N 21/00 (2006.01)**

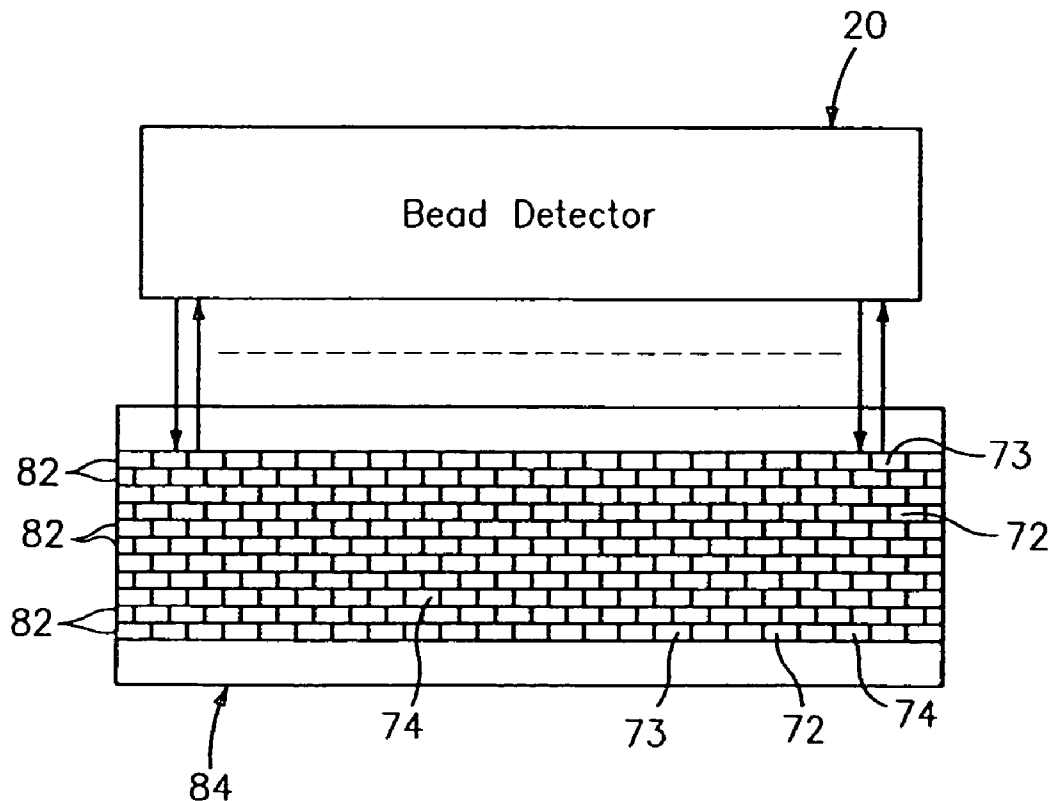

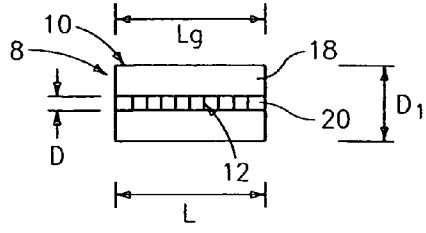

FIG. 1

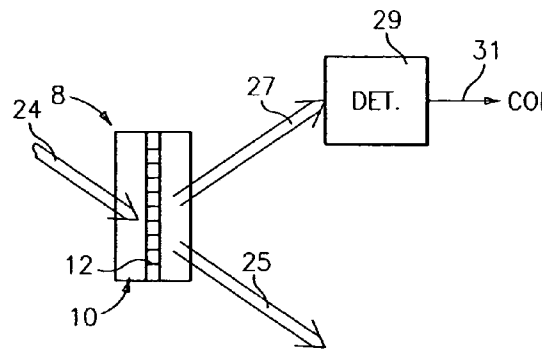

FIG. 2

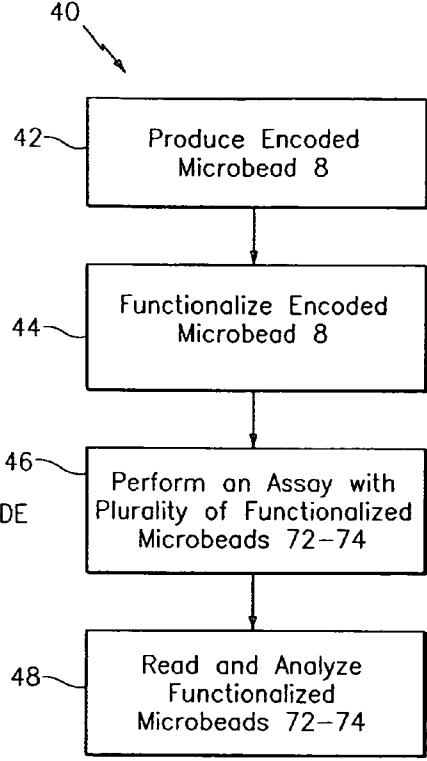

FIG. 3

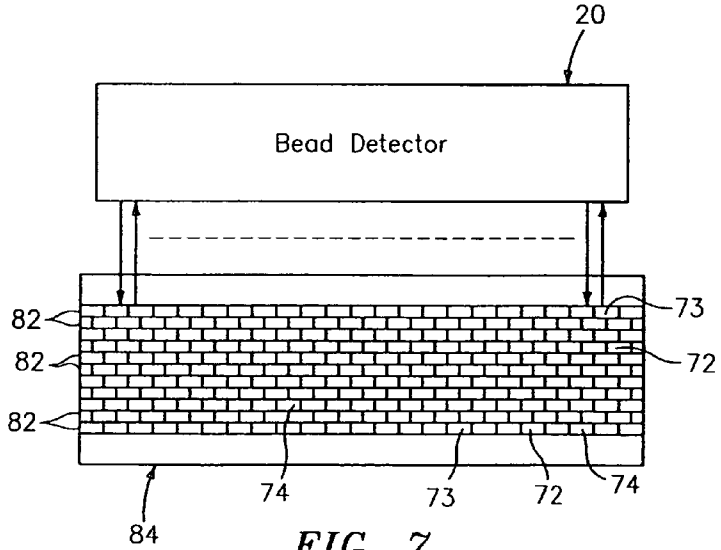

FIG. 7

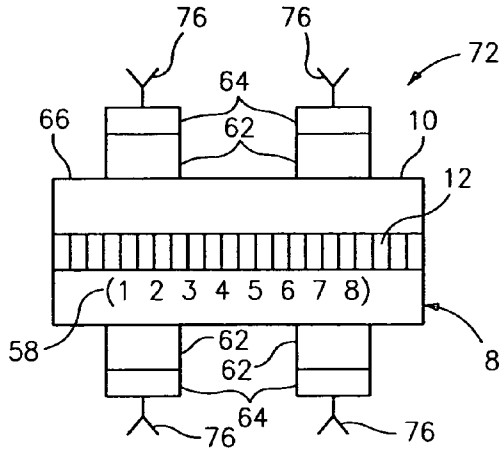

FIG. 4

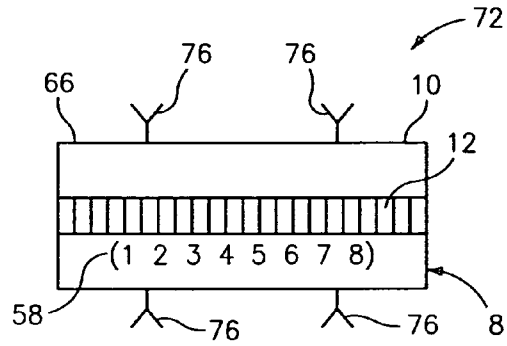

FIG. 5

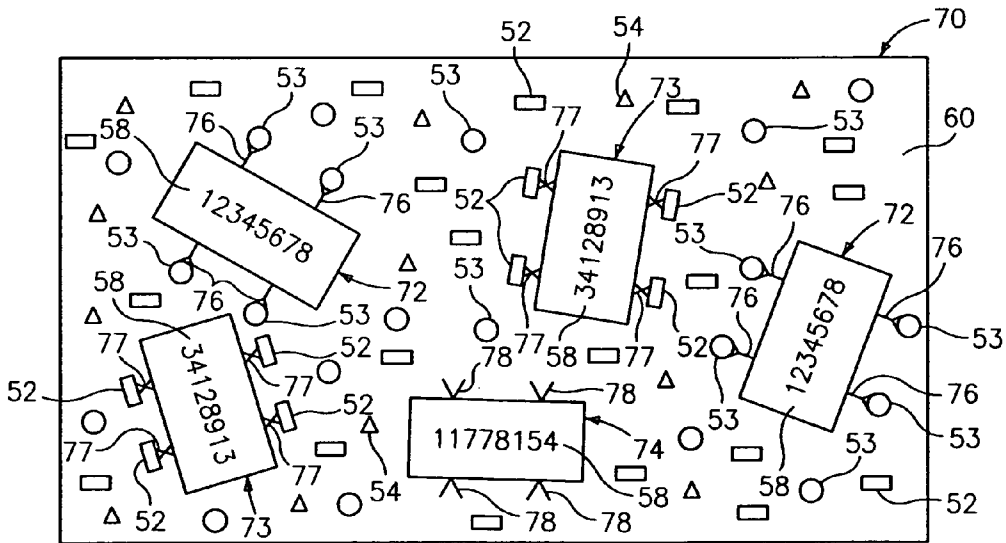

FIG. 6

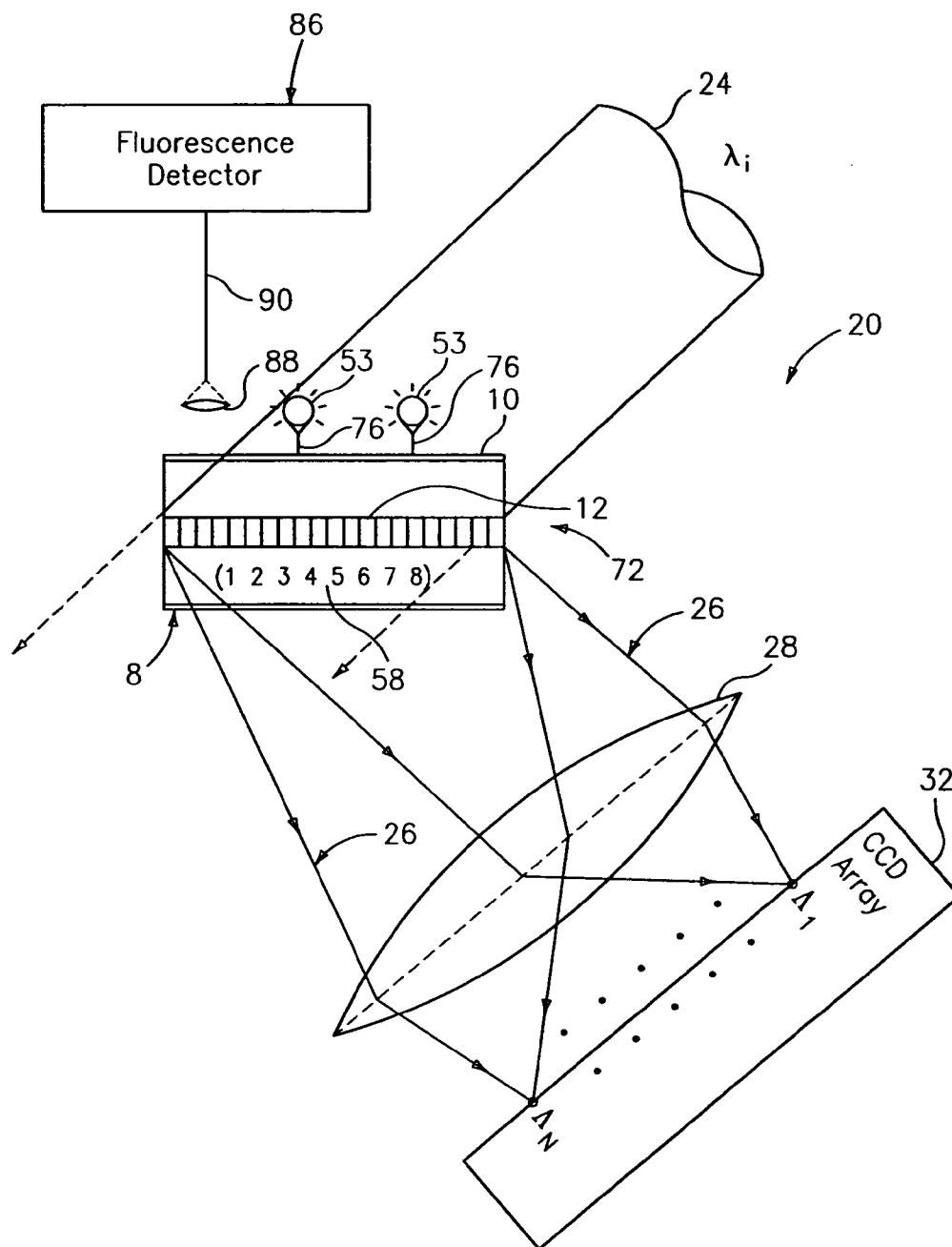

FIG. 8



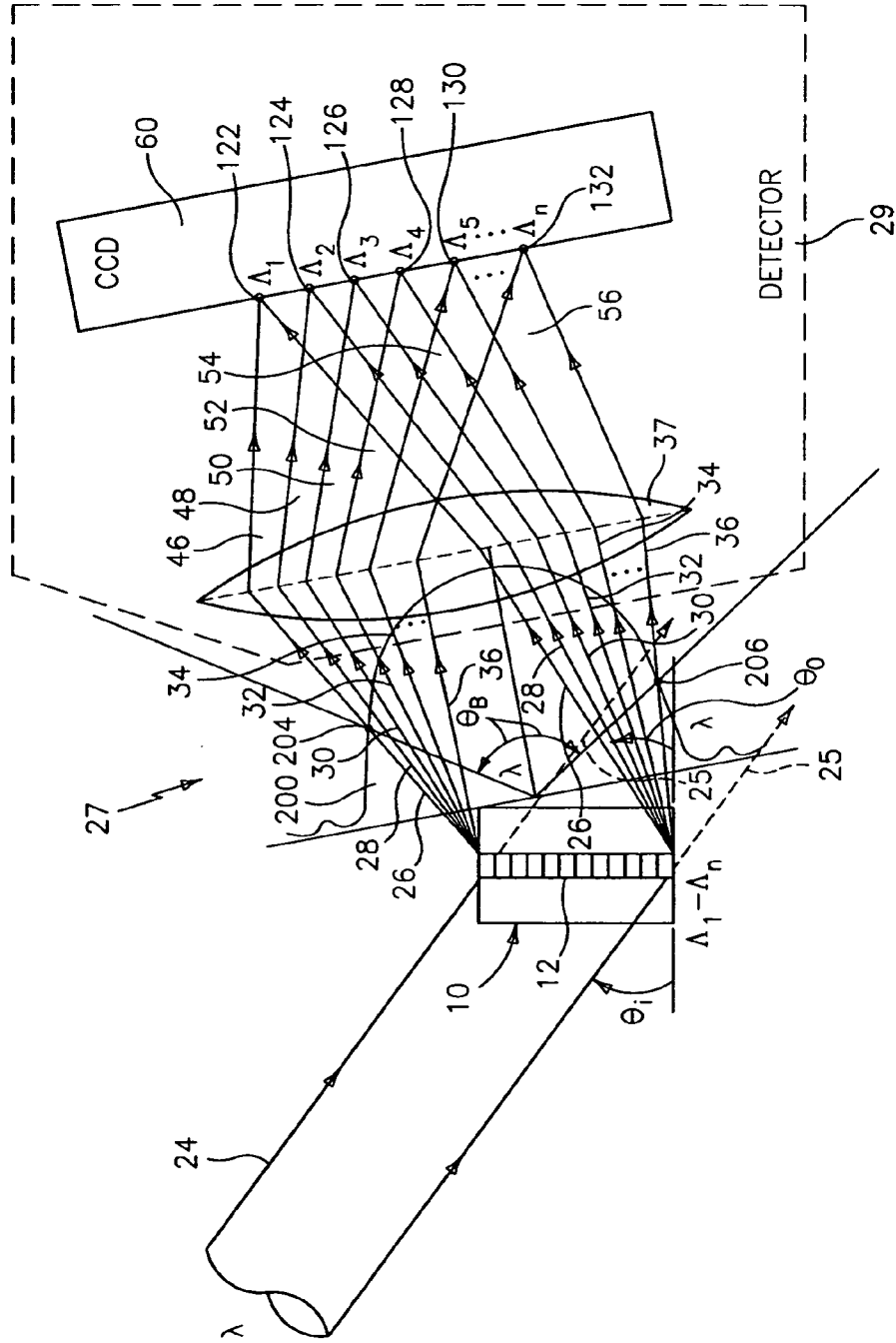

FIG. 10

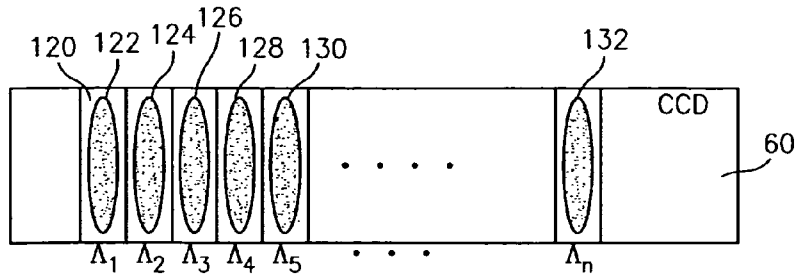

FIG. 11

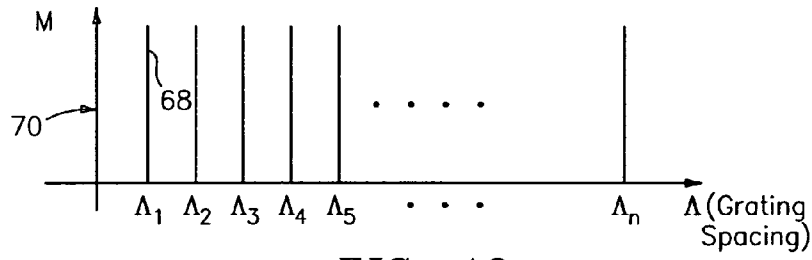
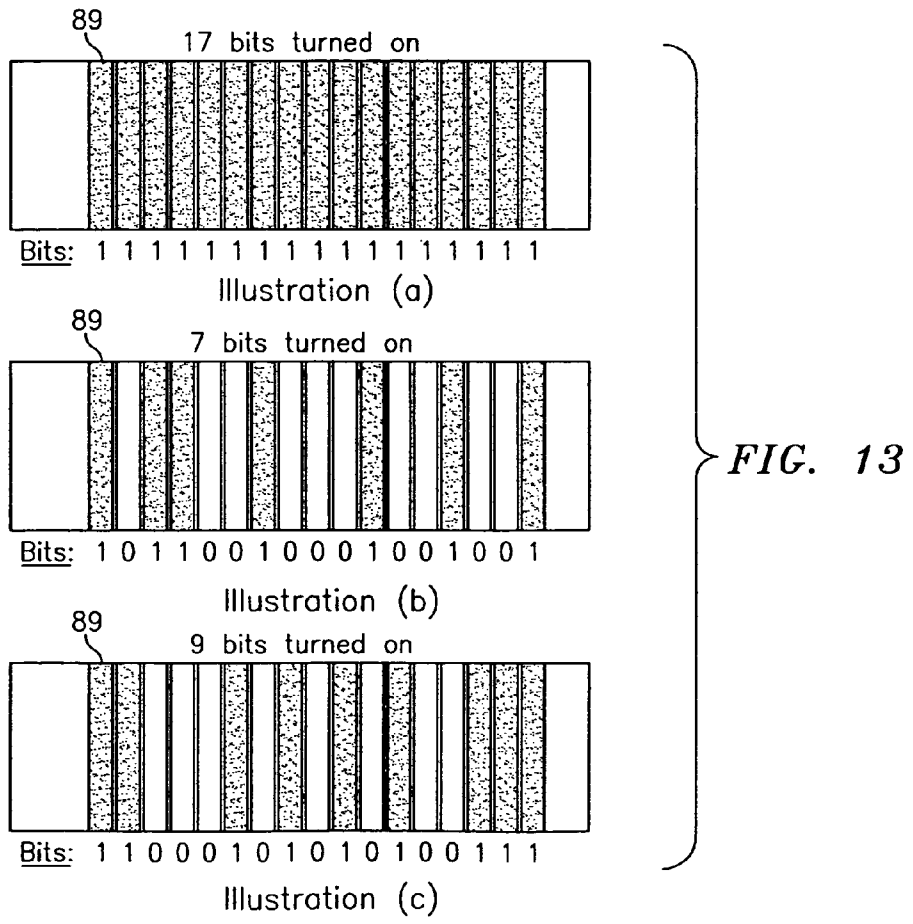

FIG. 12



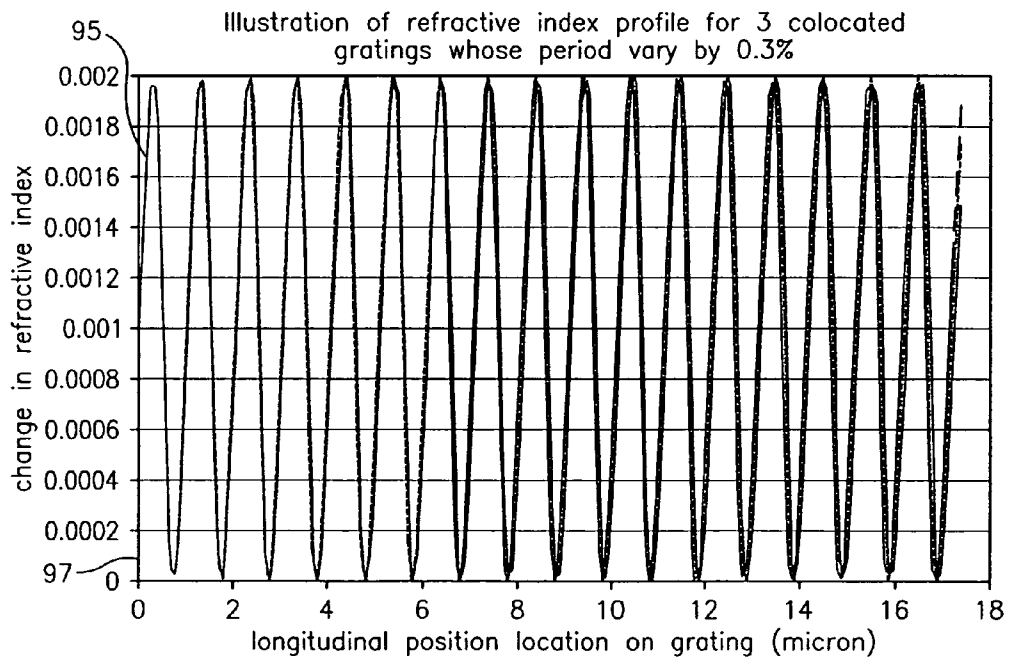
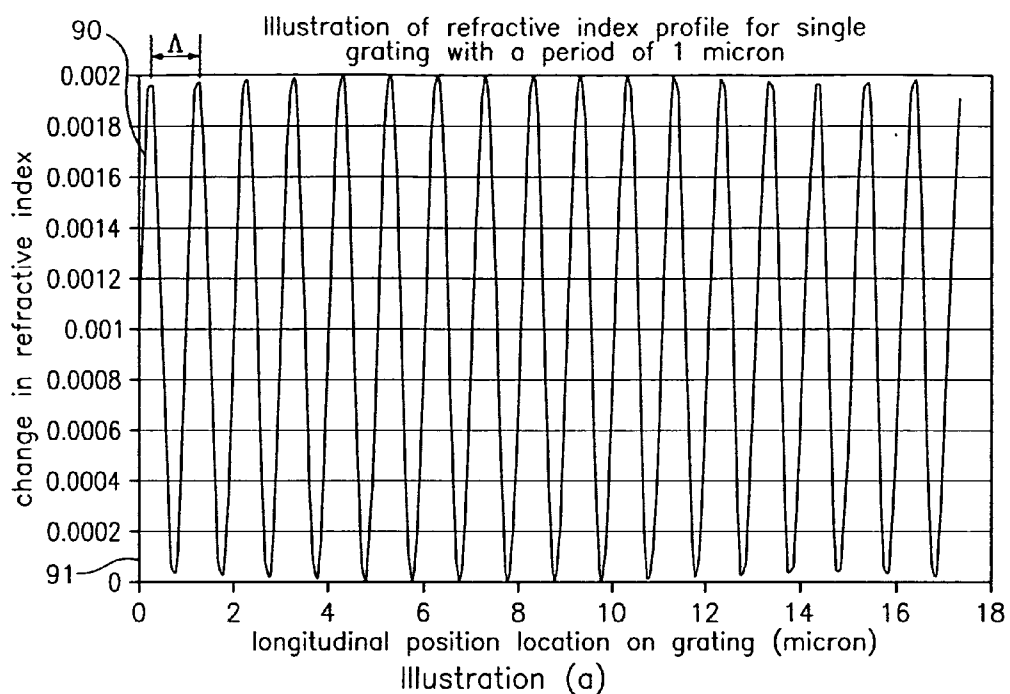

FIG. 14

--- grating 1    - - - - grating 2    — grating 3

Illustration (c)



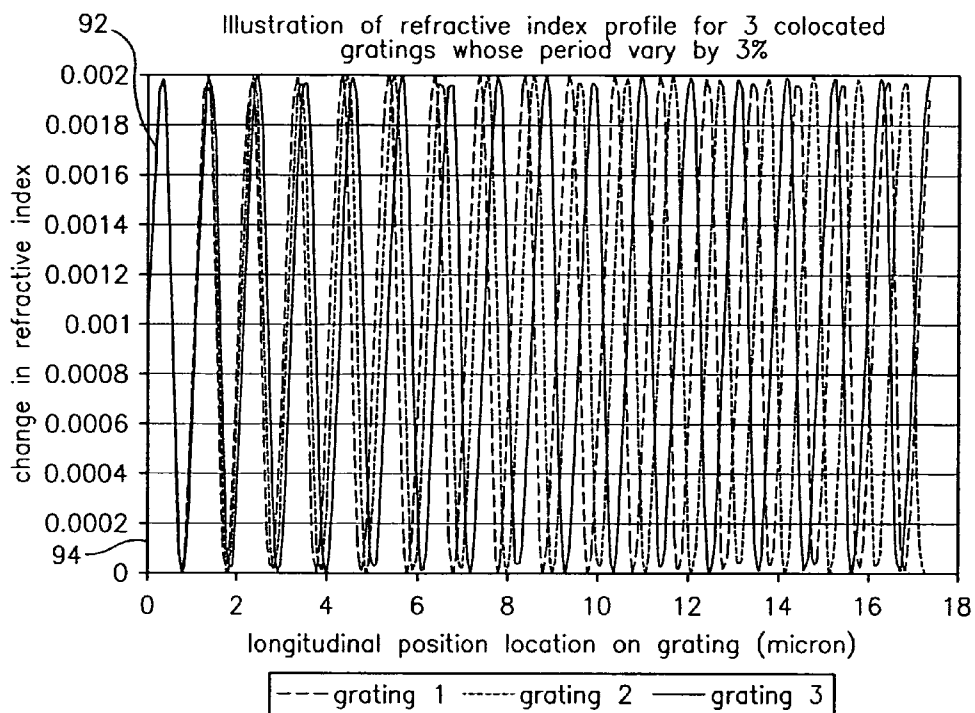

Illustration (b)

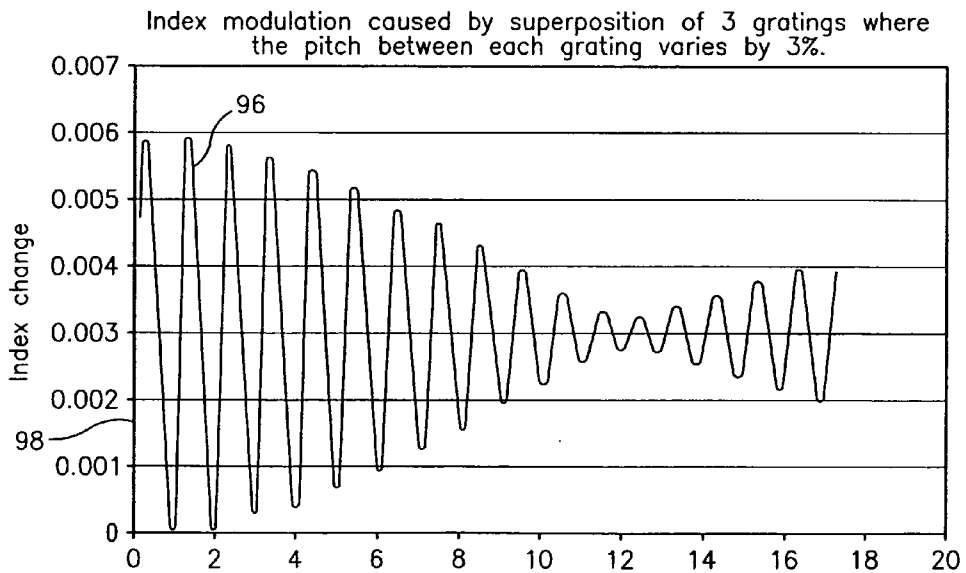

Illustration (d)

FIG. 14



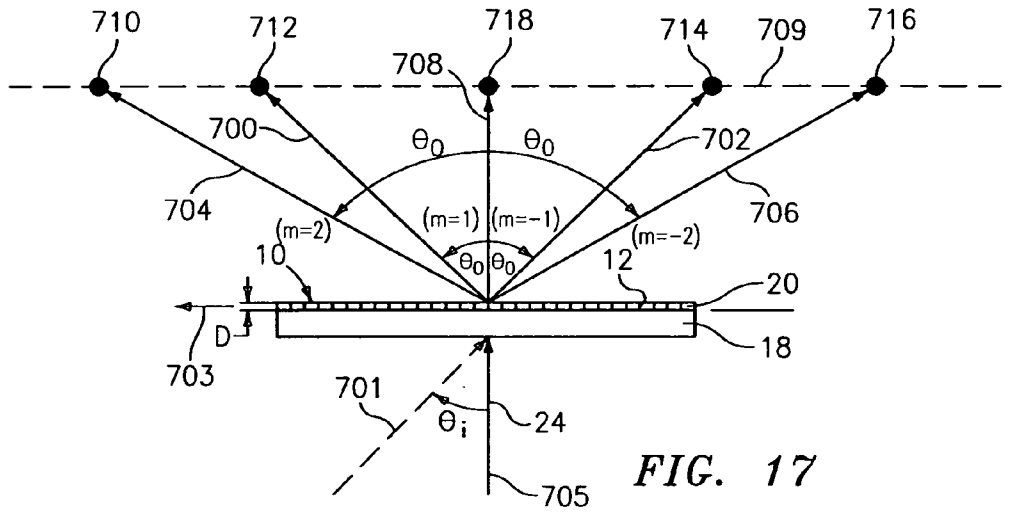
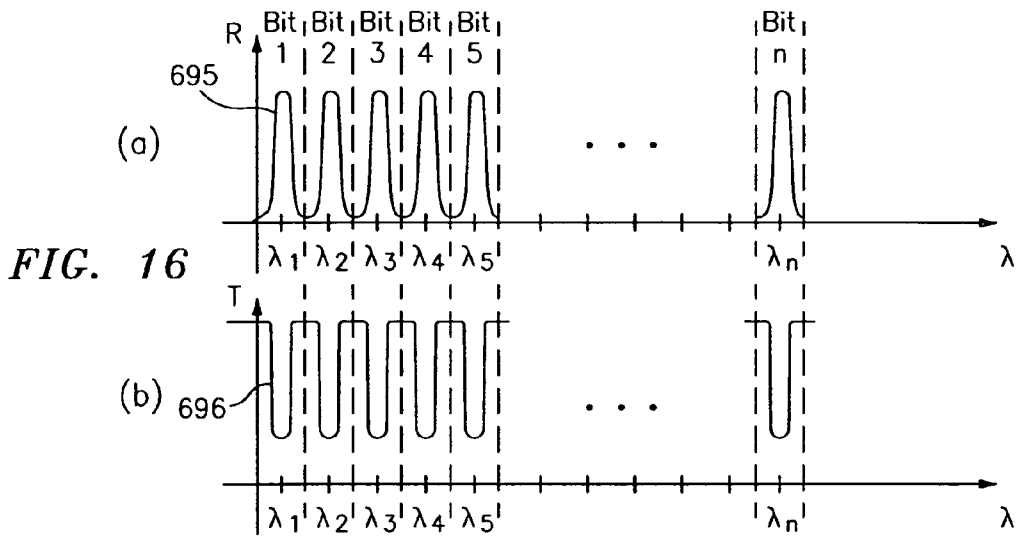

FIG. 17

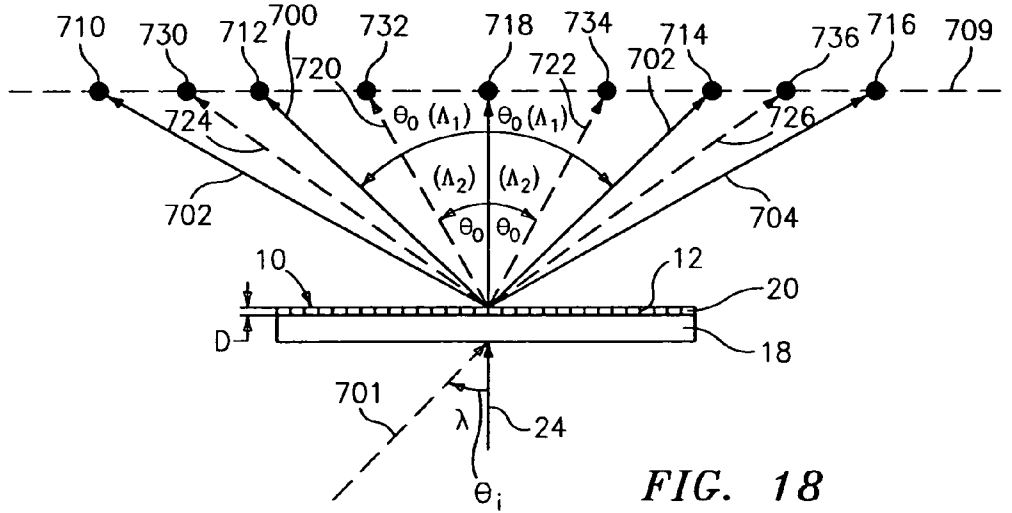

FIG. 18

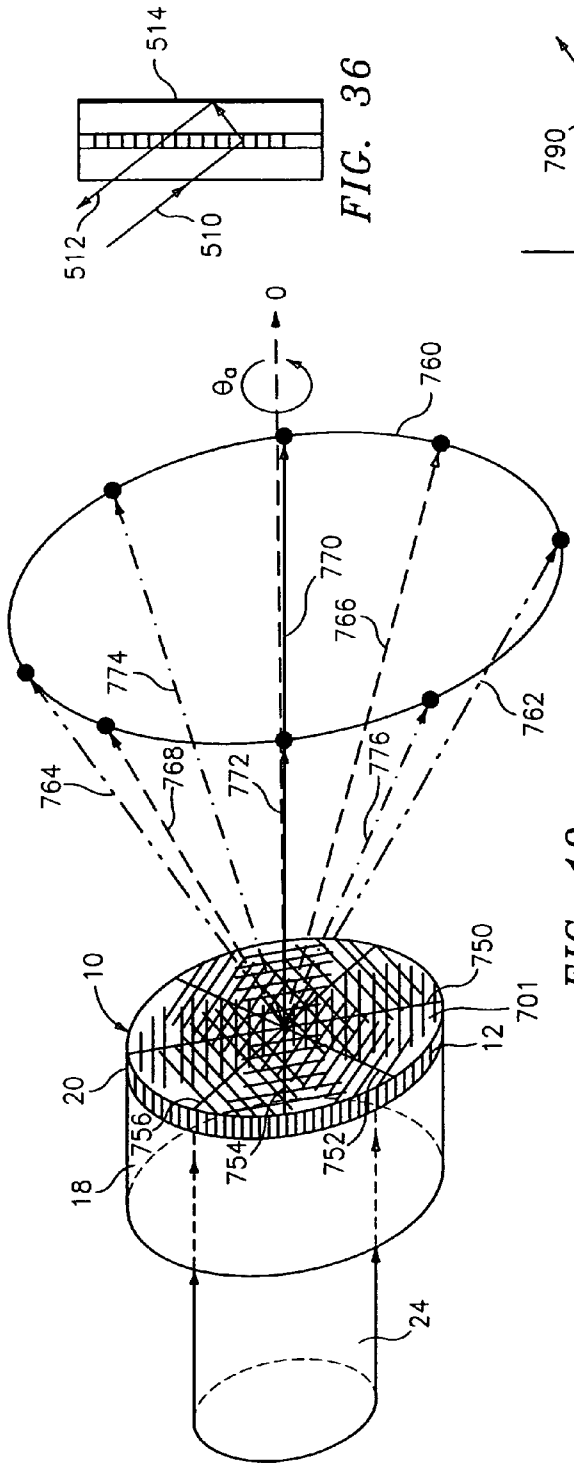

FIG. 19

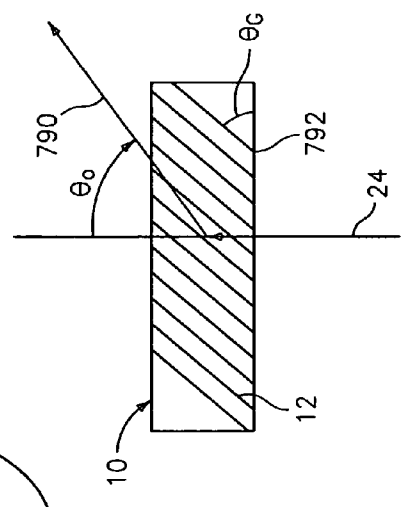

FIG. 20

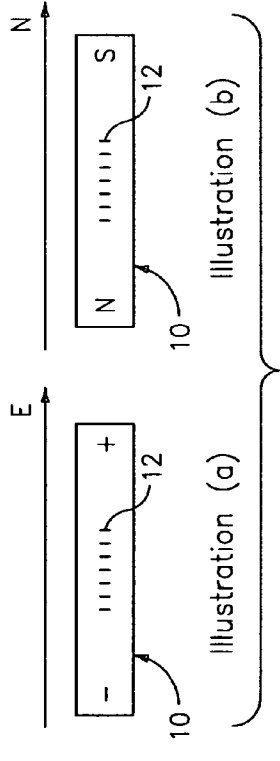

FIG. 37

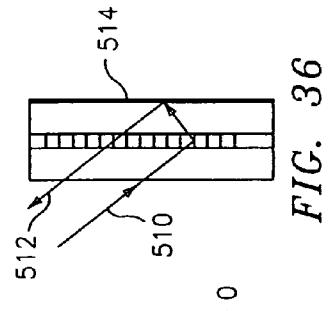

FIG. 36

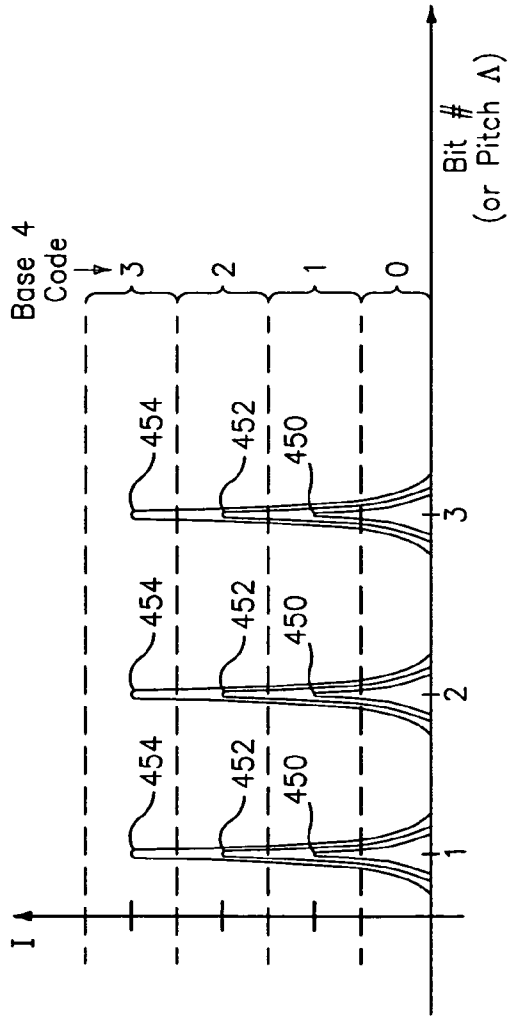

FIG. 21

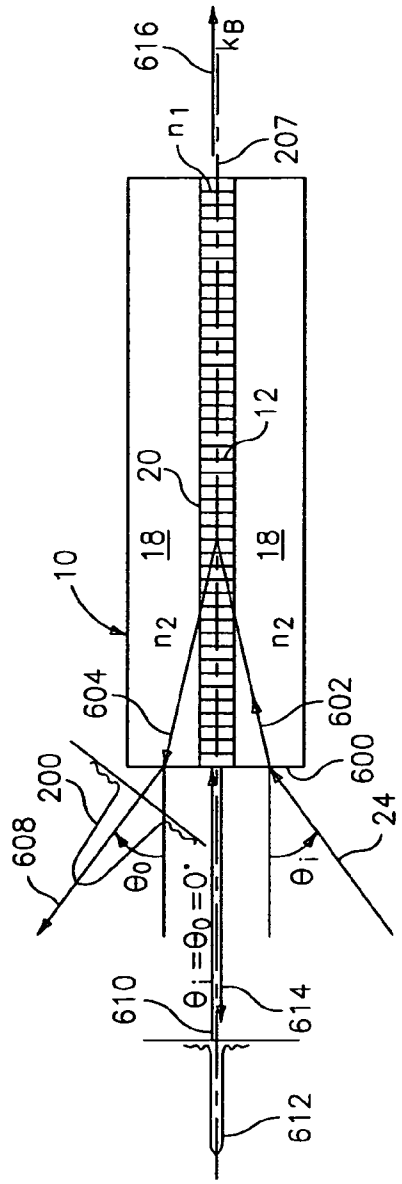

FIG. 22

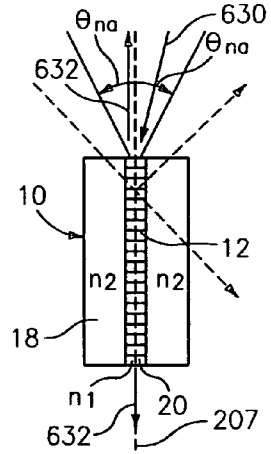

FIG. 23

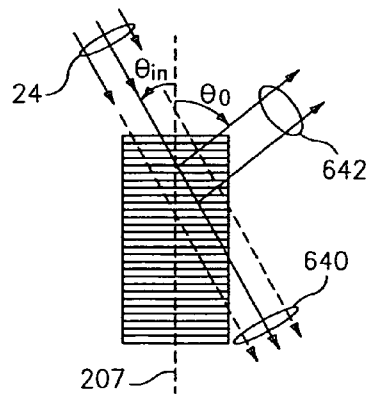

FIG. 24

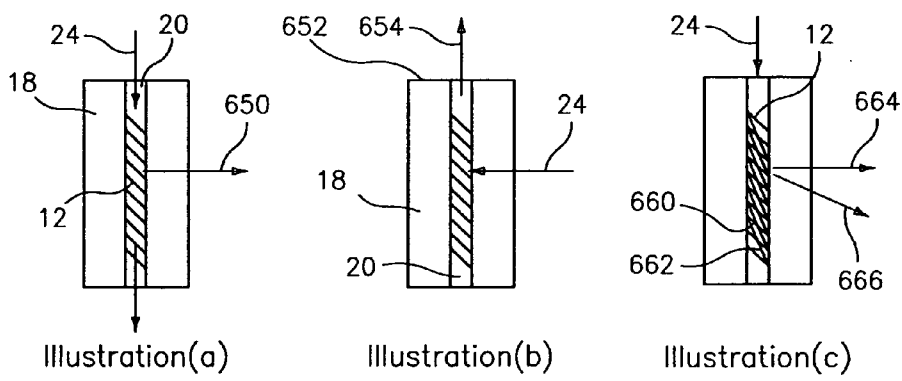

FIG. 25

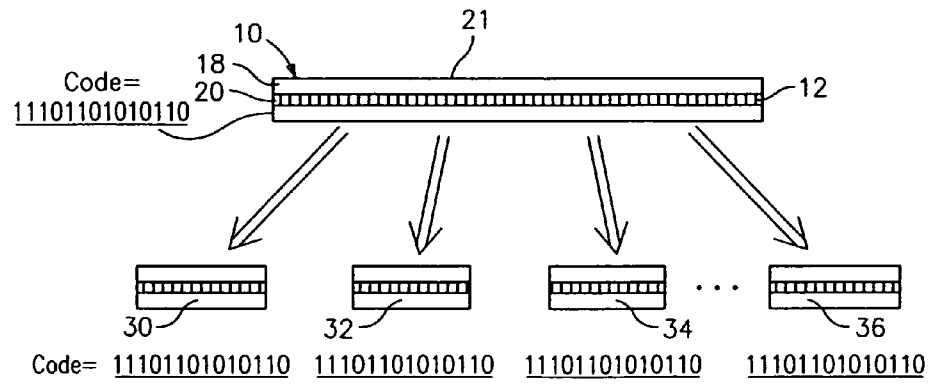

FIG. 27

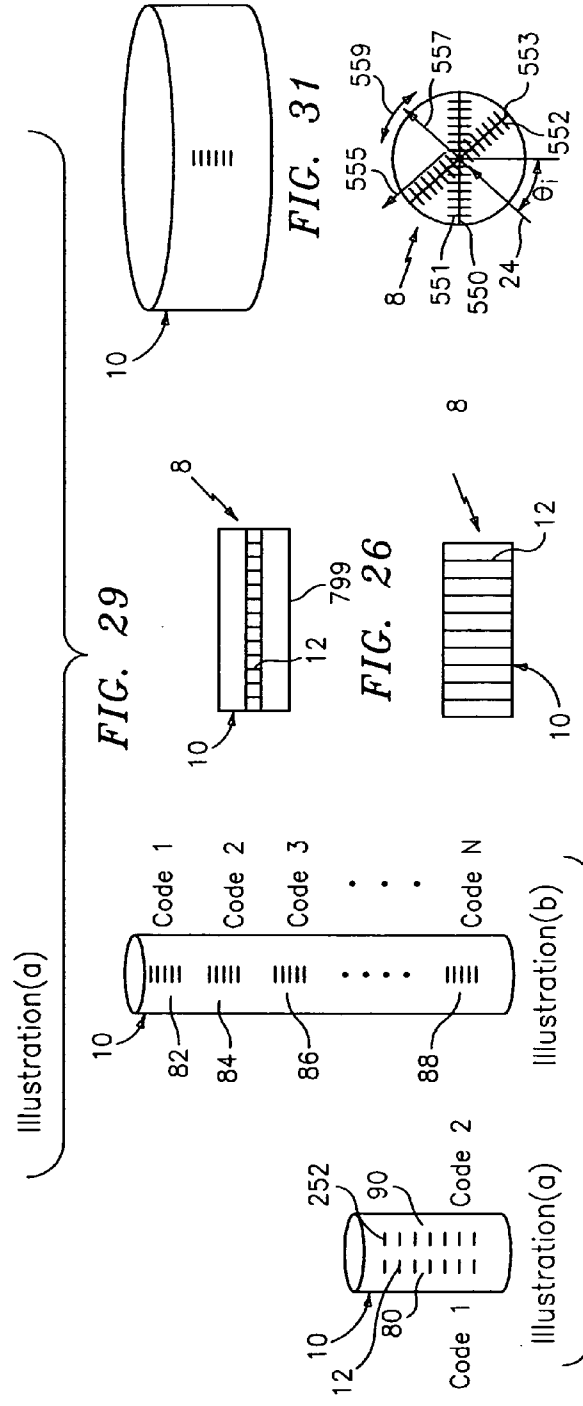
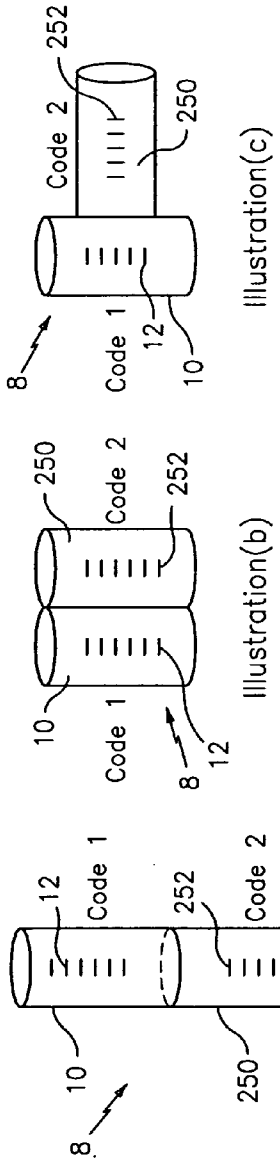

FIG. 29

FIG. 26

FIG. 28

FIG. 30

FIG. 31

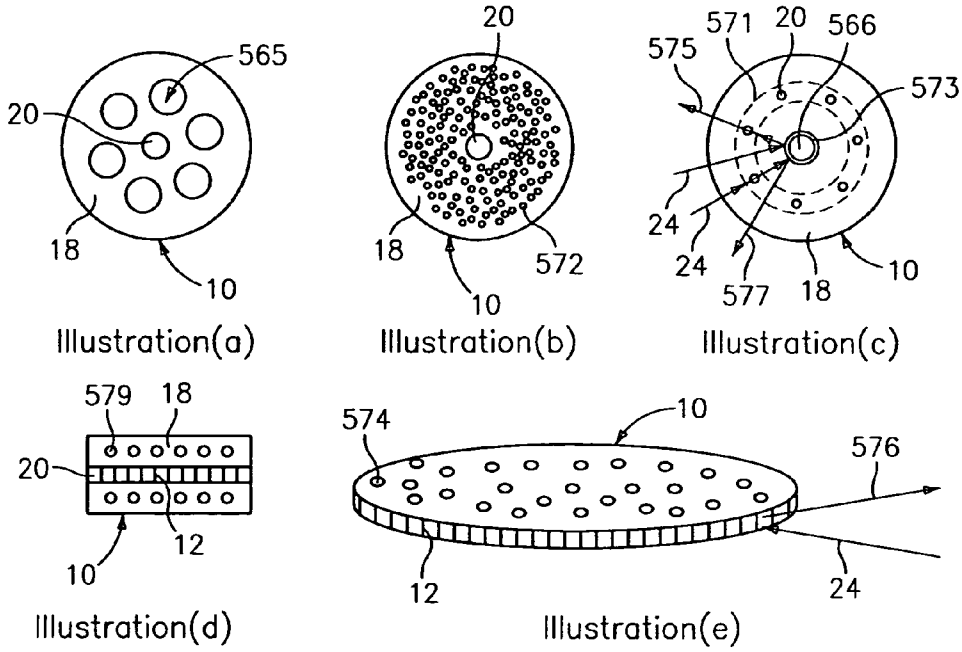

**FIG. 33**

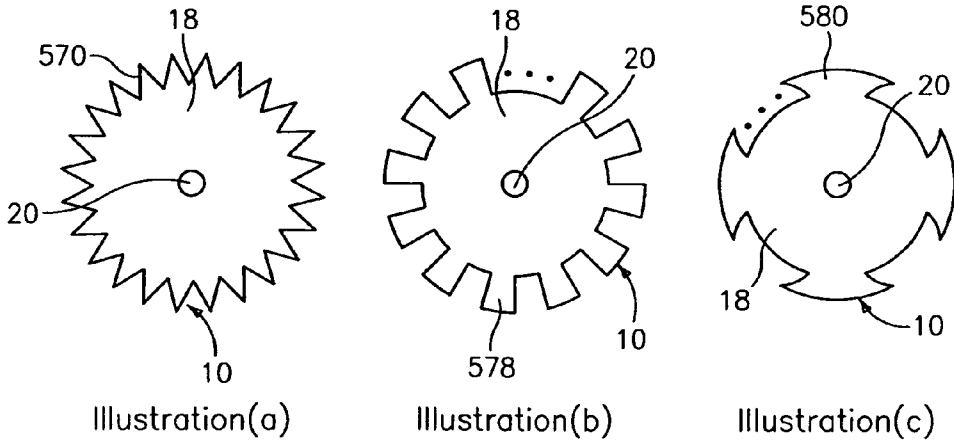

**FIG. 34**

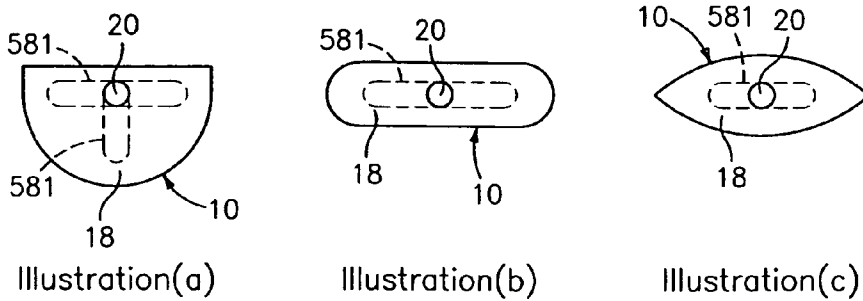

**FIG. 35**



## METHOD OF READING ENCODED PARTICLES

### CROSS-REFERENCE TO RELATE APPLICATIONS

**[0001]** This application claims the benefit of U.S. Provisional Patent Applications, Ser. No. 60/410,541 (CiDRA Docket No. CC-543), filed Sep. 12, 2002, and is a continuation-in-part of U.S. patent application Ser. No. \_\_\_\_\_ (CiDRA Docket No. CC-0649), and a continuation-in-part of U.S. patent applications Ser. No. \_\_\_\_\_ (CiDRA Docket No. CC-0649), each of which are incorporated herein by reference in their entirety.

**[0002]** U.S. patent application Ser. No. \_\_\_\_\_ (CiDRA Docket No. CC-0650A), filed contemporaneously herewith, contains subject matter related to that disclosed herein, which is incorporated by reference in its entirety.

### TECHNICAL FIELD

**[0003]** This invention relates to optical identification, and more particularly to diffraction grating-based encoded optical elements/micro-particles for performing multiplexed experiments.

### BACKGROUND ART

**[0004]** A common class of experiments, known as a multiplexed assay or multiplexed experiment, comprises mixing (or reacting) a labeled target analyte or sample (which may have known or unknown properties or sequences) with a set of “probe” or reference substances (which also may have known or unknown properties or sequences). Multiplexing allows many properties of the target analyte to be probed or evaluated simultaneously (i.e., in parallel). For example, in a gene expression assay, the “target” analyte, usually an unknown sequence of DNA, is labeled with a fluorescent molecule to form the labeled analyte.

**[0005]** In a known DNA/genomic sequencing assay, each probe consists of known DNA sequences of a predetermined length, which are attached to a labeled (or encoded) bead or to a known location on a substrate.

**[0006]** When the labeled target analyte is mixed with the probes, segments of the DNA sequence of the labeled target analyte will selectively bind to complementary segments of the DNA sequence of the known probe. The known probes are then spatially separated and examined for fluorescence. The beads that fluoresce indicate that the DNA sequence strands of the target analyte have attached or hybridized to the complementary DNA on that bead. The DNA sequences in the target analyte can then be determined by knowing the complementary DNA (or cDNA) sequence of each known probe to which the labeled target is attached. In addition the level of fluorescence is indicative of how many of the target molecules hybridized to the probe molecules for a given bead.

**[0007]** Generally, the probes are either spatially separated or otherwise labeled to identify the probe, and ultimately the “target” analyte, using one of two approaches. The first approach separates the probes in a predetermined grid, where the probe’s identity is linked to its position on the grid. One example of this is a “chip” format, where DNA is attached to a 2-D substrate or microarray, where oligomer DNA sequences are selectively attached (either by spotting or grown) onto small sections or spots on the surface of the

substrate in a predetermined spatial order and location on a substrate (usually a planar substrate, such as a glass microscope slide).

**[0008]** A second or “bead based” approach, for identifying the probe allows the probes to mix without any specific spatial position, which is often called the “random bead assay” approach. In this approach the probes are attached to a bead instead of a larger substrate so they are free to move (usually in a liquid medium). This approach has an advantage in that the analyte reaction can be performed in a liquid/solution by conventional wet-chemistry techniques, which gives the probes a better opportunity to interact with the analyte. However, this approach requires that each bead or probe be individually identifiable.

**[0009]** There are many known methods and substrate types that can be used for tagging or otherwise uniquely identifying individual beads with attached probes. Known methods include using polystyrene latex spheres that are colored or fluorescent labeled. Other methods include using small plastic cans with a conventional bar code applied, or a small container includes a solid support material and a radio-frequency tag.

**[0010]** The methods of uniquely identifying the probes, however, may be large in size, have a limited number of identifiable codes, and/or formed of material not suitable to harsh environmental condition, such as high temperature and/or corrosive material.

**[0011]** Therefore, it would be desirable to provide probes that are very small, capable of providing a large number of unique codes (e.g., greater than 1 million codes), and/or have codes intrinsic to the probe which are resistant to harsh environments.

### SUMMARY OF THE INVENTION

**[0012]** Objects of the present invention include a diffraction grating-based encoded micro-particles that are coated with a substance for multiplexed experiments, which are very small, capable of providing a large number of unique codes, and/or have are resistant to harsh environments.

**[0013]** According to the present invention, an optical identification element attached to a chemical, comprises: an optical substrate; at least a portion of said substrate having at least one diffraction grating disposed therein, said grating having at least one refractive index pitch superimposed at a common location; the grating providing an output optical signal when illuminated by an incident light signal; said optical output signal being indicative of a code in said substrate; and the chemical being attached to said substrate.

**[0014]** The invention is a significant improvement over chip based assay and existing bead assay technology, as discussed above.

**[0015]** The microbeads are inexpensive to manufacture and the identification codes are easy and inexpensive to imprint into the microbeads. The codes are digitally readable and easily adapted to optical coding techniques. Thus, the optical readout is very simple and inexpensive to implement. The code is not affected by spot imperfections, scratches, cracks or breaks. In addition, splitting or slicing an element axially produces more elements with the same code; therefore, when a bead is axially split-up, the code is not lost, but instead replicated in each piece. Unlike electronic ID elements, the elements of the present invention are not affected by nuclear or electromagnetic radiation.

[0016] The invention may be used in any assay or multiplexed experiment. The assay stick 7 may be reused or disposed upon completion of the assay.

[0017] The present invention may be used with any known combinatorial chemistry or biochemistry assay process, and are especially adaptable to assays having solid phase immobilization. The invention may be used in many areas such as drug discovery, functionalized substrates, biology, proteomics, combinatorial chemistry, and any assays or multiplexed experiments. Examples of common assays are SNP (single nucleotide polymorphism) detection, DNA/genomic sequence analysis, genotyping, gene expression assays, proteomics assay, peptide assays, antigen/antibody assays (immunoassay), ligand/receptor assays, DNA analysis/tracking/sorting/tagging, as well as tagging of molecules, biological particles, cell identification and sorting, matrix support materials, receptor binding assays, scintillation proximity assays, radioactive or non-radioactive proximity assays, and other assays, high throughput drug/genome screening, and/or massively parallel assay applications. The analyte can be labeled, detected or identified with any technique capable of being used in an assay with arrays or beads, including but not limited to fluorescent, luminescent, phosphorescent, quantum dot, light scattering colloidal particles, radioactive isotopes, mass spectroscopy, NMR (nuclear magnetic resonance), EPR (electro paramagnetic resonance), ESR (electron spin resonance), IR (infrared), FTIR (Fourier transform infra red), Raman spectroscopy, or other magnetic, vibrational, electromagnetic, or optical labeling or detection techniques. The invention provides uniquely identifiable beads with reaction supports by active coatings for reaction tracking to perform multiplexed experiments. The invention may also be used in any chemical and/or biochemical purification, isolation, or filtering-type process where bead or bead-like solid supports may be used (e.g., chromatographic techniques, such as affinity column purification). In that case, the above techniques for labeling, detection or identification may be used.

[0018] The foregoing and other objects, features and advantages of the present invention will become more apparent in light of the following detailed description of exemplary embodiments thereof.

#### BRIEF DESCRIPTION OF THE DRAWINGS

[0019] FIG. 1 is a side view of an optical identification element, in accordance with the present invention.

[0020] FIG. 2 is a top level optical schematic for reading a code in an optical identification element, in accordance with the present invention.

[0021] FIG. 3 is a flow chart of the method of attaching a substance to an optical identification element, performing an assay and analyzing the optical identification element, in accordance with the present invention.

[0022] FIG. 4 is a side view of an optical identification element having a substance attached to the outer surface thereof, in accordance with the present invention.

[0023] FIG. 5 is a side view of an optical identification element having a substance attached to the outer surface thereof, in accordance with the present invention.

[0024] FIG. 6 is a schematic view of a plurality of optical identification elements having different identification or codes and coated with different probe substances disposed in a cell with a plurality of test substances, in accordance with the present invention.

[0025] FIG. 7 is a schematic view of plurality of optical identification elements after the performance of an assay, aligned in a plurality of grooves, disposed on a substrate, and a bead detector that scans each optical identification element for determining the code and fluorescence of each optical identification element, in accordance with the present invention.

[0026] FIG. 8 is a side view of an optical identification element after the performance of an assay, and a bead detector that determines the code and fluorescence of the optical identification element, in accordance with the present invention.

[0027] FIG. 9 is a side view of an optical identification element after the performance of an assay, and a more detailed view of a bead detector that determines the code and fluorescence of the optical identification element, in accordance with the present invention.

[0028] FIG. 10 is an optical schematic for reading a code in an optical identification element, in accordance with the present invention.

[0029] FIG. 11 is an image of a code on a CCD camera from an optical identification element, in accordance with the present invention.

[0030] FIG. 12 is a graph showing a digital representation of bits in a code in an optical identification element, in accordance with the present invention.

[0031] FIG. 13 illustrations (a)-(c) show images of digital codes on a CCD camera, in accordance with the present invention.

[0032] FIG. 14 illustrations (a)-(d) show graphs of different refractive index pitches and a summation graph, in accordance with the present invention.

[0033] FIG. 15 is an alternative optical schematic for reading a code in an optical identification element, in accordance with the present invention.

[0034] FIG. 16 illustrations (a)-(b) are graphs of reflection and transmission wavelength spectrum for an optical identification element, in accordance with the present invention.

[0035] FIGS. 17-18 are side views of a thin grating for an optical identification element, in accordance with the present invention.

[0036] FIG. 19 is a perspective view showing azimuthal multiplexing of a thin grating for an optical identification element, in accordance with the present invention.

[0037] FIG. 20 is side view of a blazed grating for an optical identification element, in accordance with the present invention.

[0038] FIG. 21 is a graph of a plurality of states for each bit in a code for an optical identification element, in accordance with the present invention.

[0039] FIG. 22 is a side view of an optical identification element where light is incident on an end face, in accordance with the present invention.

[0040] FIGS. 23-24 are side views of an optical identification element where light is incident on an end face, in accordance with the present invention.

[0041] FIG. 25, illustrations (a)-(c) are side views of an optical identification element having a blazed grating, in accordance with the present invention.

[0042] FIG. 26 is a side view of an optical identification element having a coating, in accordance with the present invention.

[0043] FIG. 27 is a side view of whole and partitioned optical identification element, in accordance with the present invention.

[0044] FIG. 28 is a side view of an optical identification element having a grating across an entire dimension, in accordance with the present invention.

[0045] FIG. 29, illustrations (a)-(c), are perspective views of alternative embodiments for an optical identification element, in accordance with the present invention.

[0046] FIG. 30, illustrations (a)-(b), are perspective views of an optical identification element having multiple grating locations, in accordance with the present invention.

[0047] FIG. 31, is a perspective view of an alternative embodiment for an optical identification element, in accordance with the present invention.

[0048] FIG. 32 is a view an optical identification element having a plurality of gratings located rotationally around the optical identification element, in accordance with the present invention.

[0049] FIG. 33 illustrations (a)-(e) show various geometries of an optical identification element that may have holes therein, in accordance with the present invention.

[0050] FIG. 34 illustrations (a)-(c) show various geometries of an optical identification element that may have teeth thereon, in accordance with the present invention.

[0051] FIG. 35 illustrations (a)-(c) show various geometries of an optical identification element, in accordance with the present invention.

[0052] FIG. 36 is a side view an optical identification element having a reflective coating thereon, in accordance with the present invention.

[0053] FIG. 37 illustrations (a)-(b) are side views of an optical identification element polarized along an electric or magnetic field, in accordance with the present invention.

#### BEST MODE FOR CARRYING OUT THE INVENTION

[0054] Referring to FIG. 1, a diffraction grating-based optical identification element 8 (or encoded element or coded element) comprises a known optical substrate 10, having an optical diffraction grating 12 disposed (or written, impressed, embedded, imprinted, etched, grown, deposited or otherwise formed) in the volume of or on a surface of a substrate 10. The grating 12 is a periodic or aperiodic variation in the effective refractive index and/or effective optical absorption of at least a portion of the substrate 10.

[0055] The optical identification element 8 described herein is the same as that described in Copending patent application Ser. No. \_\_\_\_\_ (CiDRA Docket No. CC-0648A), filed contemporaneously herewith, which is incorporated herein by reference in its entirety.

[0056] In particular, the substrate 10 has an inner region 20 where the grating 12 is located. The inner region 20 may be photosensitive to allow the writing or impressing of the grating 12. The substrate 10 has an outer region 18, which does not have the grating 12 therein.

[0057] The grating 12 is a combination of one or more individual spatial periodic sinusoidal variations (or components) in the refractive index that are collocated at substantially the same location on the substrate 10 along the length of the grating region 20, each having a spatial period (or pitch)  $\Lambda$ . The resultant combination of these individual pitches is the grating 12, comprising spatial periods ( $\Lambda_1$ - $\Lambda_n$ ) each representing a bit in the code. Thus, the grating 12

represents a unique optically readable code, made up of bits, where a bit corresponds to a unique pitch  $\Lambda$  within the grating 12. Accordingly, for a digital binary (0-1) code, the code is determined by which spatial periods ( $\Lambda_1$ - $\Lambda_n$ ) exist (or do not exist) in a given composite grating 12. The code or bits may also be determined by additional parameters (or additional degrees of multiplexing), and other numerical bases for the code may be used, as discussed herein and/or in the aforementioned patent application.

[0058] The grating 12 may also be referred to herein as a composite or collocated grating. Also, the grating 12 may be referred to as a "hologram", as the grating 12 transforms, translates, or filters an input optical signal to a predetermined desired optical output pattern or signal.

[0059] The substrate 10 has an outer diameter D1 and comprises silica glass ( $\text{SiO}_2$ ) having the appropriate chemical composition to allow the grating 12 to be disposed therein or thereon. Other materials for the optical substrate 10 may be used if desired. For example, the substrate 10 may be made of any glass, e.g., silica, phosphate glass, borosilicate glass, or other glasses, or made of glass and plastic, or solely plastic. For high temperature or harsh chemical applications, the optical substrate 10 made of a glass material is desirable. If a flexible substrate is needed, plastic, rubber or polymer-based substrate may be used. The optical substrate 10 may be any material capable of having the grating 12 disposed in the grating region 20 and that allows light to pass through it to allow the code to be optically read.

[0060] The optical substrate 10 with the grating 12 has a length L and an outer diameter D1, and the inner region 20 diameter D. The length L can range from very small "microbeads" (or microelements, micro-particles, or encoded particles), about 1-1000 microns or smaller, to larger "macroelements" for larger applications (about 1.0-1000 mm or greater). In addition, the outer dimension D1 can range from small (less than 1000 microns) to large (1.0-1000 mm and greater). Other dimensions and lengths for the substrate 10 and the grating 12 may be used.

[0061] The grating 12 may have a length  $L_g$  of about the length L of the substrate 10. Alternatively, the length  $L_g$  of the grating 12 may be shorter than the total length L of the substrate 10.

[0062] The outer region 18 is made of pure silica ( $\text{SiO}_2$ ) and has a refractive index  $n_2$  of about 1.458 (at a wavelength of about 1553 nm), and the inner grating region 20 of the substrate 10 has dopants, such as germanium and/or boron, to provide a refractive index  $n_1$  of about 1.453, which is less than that of outer region 18 by about 0.005. Other indices of refraction  $n_1, n_2$  for the grating region 20 and the outer region 18, respectively, may be used, if desired, provided the grating 12 can be impressed in the desired grating region 20. For example, the grating region 20 may have an index of refraction that is larger than that of the outer region 18 or grating region 20 may have the same index of refraction as the outer region 18 if desired.

[0063] Referring to FIG. 2, an incident light 24 of a wavelength  $\lambda$ , e.g., 532 nm from a known frequency doubled Nd:YAG laser or 632 nm from a known Helium-Neon laser, is incident on the grating 12 in the substrate 10. Any other input wavelength  $\lambda$  can be used if desired provided  $\lambda$  is within the optical transmission range of the substrate (discussed more herein and/or in the aforementioned patent application). A portion of the input light 24 passes straight through the grating 12, as indicated by a line

25. The remainder of the input light 24 is reflected by the grating 12, as indicated by a line 27 and provided to a detector 29. The output light 27 may be a plurality of beams, each having the same wavelength  $\lambda$  as the input wavelength  $\lambda$  and each having a different output angle indicative of the pitches ( $\Lambda_1$ - $\Lambda_n$ ) existing in the grating 12. Alternatively, the input light 24 may be a plurality of wavelengths and the output light 27 may have a plurality of wavelengths indicative of the pitches ( $\Lambda_1$ - $\Lambda_n$ ) existing in the grating 12. Alternatively, the output light may be a combination of wavelengths and output angles. The above techniques are discussed in more detail herein and/or in the aforementioned patent application.

[0064] The detector 29 has the necessary optics, electronics, software and/or firmware to perform the functions described herein. In particular, the detector reads the optical signal 27 diffracted or reflected from the grating 12 and determines the code based on the pitches present or the optical pattern, as discussed more herein or in the aforementioned patent application. An output signal indicative of the code is provided on a line 31.

[0065] Referring to FIGS. 3-8, the substrate 10 of the optical identification element (or microbead) 8 may be functionalized by coating or attaching a desired probe 76, such as a compound, chemical or molecule, which is then used in an assay as an attractant for certain complimentary compounds, chemicals or molecules, otherwise known as a "target" analyte 52-54 (see FIG. 6). This capability to uniquely encode a large number of microbeads 8 with a corresponding unique probe 76 attached thereto enables these functionalized microbeads 72 to be mixed with unknown "target" analytes 52-54 to perform a multiplexed experiment. The procedure 40 for performing such a multiplexed assay or experiment includes the steps of producing (step 42) the microbead 8, as described hereinbefore, and functionalizing (step 44) the substrate 10 of the microbead 8 by coating/depositing/growing it with a probe 76 that will react in a predetermined way with "target" analytes 52-54. An assay is then performed (step 46) with a plurality of functionalized microbeads 72 with different identification codes 58 at the same time. In step 48, the fluorescence of the functionalized microbeads 72 is analyzed, and the functionalized microbead 72 is read to determine the code 58 thereof to thereby determine which "target" analytes 5-54 are present in the solution 60.

[0066] In FIGS. 4 and 5, a functionalized microbead 72 is shown, wherein the substrate 10 of the microbead 8 is coated with a probe 76 and used in an assay or as an attractant for certain "target" analytes 52-54 (see FIG. 6). In one embodiment shown in FIG. 4, the microbead 8 is coated with a linker molecule or complex 62 as is known in the art. A molecular group 64 is attached to the probe 76 to enable the probe to be bonded to the linker molecule or complex 62, and thus to the microbead 8 to form the functionalized microbead 72. The probe 76 may include one of an Oligonucleotides (oligos), antibodies, peptides, amino acid strings, cDNA, RNA, chemicals, nucleic acid oligomers, polymers, biological cells, or proteins. For example, the probe 76 may comprise a single strand of DNA (or portion thereof) and the "target" analyte 52-54 comprises at least one unknown single strand of DNA, wherein each different "target" analyte has a different DNA sequence.

[0067] In some instances as shown in FIG. 5, the probe 76 may be attached directly to the substrate 10 of the microbead

8, or directly synthesized (or grown) thereon, such as via phosphoramidite chemistry. Examples of surface chemistry for the functionalized microbeads 72 include Streptavidin/biotinylated oligos and Aldehyde/amine modified oligos. Further, the microbead may be coated with a blocker of non-specific binding (e.g., salmon sperm DNA) to prevent bonding of analytes 52-54 (e.g. DNA) to the non-functionalized surface 66 of the functionalized microbeads 72.

[0068] Referring to FIG. 6, an assay is performed by adding a solution 60 of different types of "target" analytes 52-54 into a cell or container 70 having a plurality of functionalized microbeads 72-74 disposed therein. As discussed in step 46 of FIG. 3, the functionalized microbeads 72-74 placed in the cell 70 have different identification codes 58 that correspond to unique probes 76-78 bonded thereto. For example, all functionalized microbeads 72 disposed within the cell 70 having an identification code of 12345678 is coated with a unique probe 76. All functionalized microbeads 73 disposed within the cell 72 having an identification code of 34128913 is coated with a unique probe 77. All functionalized microbeads 77 disposed within the cell 70 having an identification code of 11778154 is coated with a unique probe 78.

[0069] The "target" analytes 52-54 within the solution 60 are then mixed with the functionalized microbeads 72-74. During the mixing of the "target" analytes 52-54 and the functionalized microbeads 72-74, the "target" analytes attach to the complementary probes 76-78, as shown for functionalized microbeads 72,73 having codes 12345678 and 34128913. Specifically, as shown in FIG. 6, "target" analytes 53 bonded with probes 76 of the functionalized microbeads 72 having the code 12345678, and "target" analytes 52 bonded with probes 77 of the functionalized microbeads 73 having the code 34128913. On the other hand, "target" analytes 54 did not bond with any probes, and not "target" analytes 52-54 in the solution 60 bonded with probes 78 of the functionalized microbeads 74 having the code 11778154. Consequently, knowing which "target" analytes attach to which probes along with the capability of identifying each probe by the encoded microbead, the results of the assay would show that the unknown "target" analytes in the solution 60 includes "target" analytes 53, 54, as will be described in further detail.

[0070] For example as discussed hereinbefore, each coded functionalized microbead 72-74 has a unique probe 76-78, respectively bonded thereto, such as a portion of a single strand of DNA. Similarly, the "target" analytes 52-54 comprise a plurality of unknown and unique single strands of DNA. These "target" analytes 52-54 are also processed with a fluorescent, such as dyeing, such that the test molecules illuminate. As will be discussed hereinafter, the fluorescence of the "target" analytes provide the means to identify, which functionalized microbeads 72-74 have a "target" analyte attached thereto.

[0071] Once the reaction or combining is complete, the functionalized microbeads 72-74 are rinsed off with a saline solution to clean off the uncombined "target" analytes 52-54. As shown in FIG. 7, the functionalized microbeads 72-74 may be placed in a tray 84 with grooves 82 to allow the functionalized microbeads to be aligned in a predetermined direction, such as that described in U.S. patent application Ser. No. \_\_\_\_\_ (Cidra Docket No. CC-0648), filed contemporaneously, which is incorporated herein by reference. The grooves 82 may have holes (not shown) that provide

suction to keep the functionalized microbeads in position. Once aligned in the tray **84**, the functionalized microbeads **52-54** are individually scanned and analyzed by the bead detector **20**.

[0072] As best shown in FIG. **8**, each functionalized microbead **72-74** is detected for fluorescence and analyzed to determine the identification code **58** of the functionalized microbeads. A light source (not shown) may be provided to illuminate the microbeads **72-74**. Once the fluorescent microbeads **72-74** are identified and knowing which probe **76-78** (or single strand of DNA) was attached to each coded, functionalized microbead **72-74**, the bead detector **20** determines which "target" analytes **52-54** were present in the solution **60**. As described hereinbefore, the bead detector **20** illuminates the functionalized microbeads **72-74** and focuses light **26** reflected by the diffraction grating **12** onto a CCD array or camera **32**, whereby the code **58** of the functionalized microbead **72-74** is determined. Secondly, the bead detector **20** includes a fluorescence detector **86** for measuring the fluorescence emanating from "target" analytes **52-54** attached to the probes **76-78**. The fluorescence meter **86** includes a lens **88** and optical fiber **90** for receiving and providing the fluorescence from the "target" analyte **52-54** to the fluorescence meter.

[0073] Referring to FIG. **9**, more specifically, the codes in the microbeads **8** are detected when illuminated by incident light **24** which produces a diffracted or output light signal **27** to a reader **820**, which includes the optics and electronics necessary to read the codes in each bead **8**, as described herein and/or in the aforementioned copending patent application. The reader **820** provides a signal on a line **822** indicative of the code in each of the bead **8**. The incident light **24** may be directed transversely from the side of the tray **84** (or from an end or any other angle) with a narrow band (single wavelength) and/or multiple wavelength source, in which case the code is represented by a spatial distribution of light and/or a wavelength spectrum, respectively, as described hereinafter and in the aforementioned copending patent application. Other illumination, readout techniques, types of gratings, geometries, materials, etc. may be used for the microbeads **8**, as discussed hereinafter and in the aforementioned patent application.

[0074] For assays that use fluorescent molecule markers to label or tag chemicals, an optical excitation signal **800** is incident on the microbeads **8** through the tray **84** and a fluorescent optical output signal **802** emanates from the beads **8** that have the fluorescent molecule attached. The fluorescent optical output signal **802** passes through a lens **804**, which provides focused light **802** to a known optical fluorescence detector **808**. Instead of or in addition to the lens **802**, other imaging optics may be used to provide the desired characteristics of the optical image/signal onto the fluorescence detector **808**. The detector **808** provides an output signal on a line **810** indicative of the amount of fluorescence on a given bead **8**, which can then be interpreted to determine what type of chemical is attached to the bead **10**.

[0075] The tray **84** is made of glass or plastic or any material that is transparent to the code reading incident beam **24** and code reading output light beams **27** as well as the fluorescent excitation beam **800** and the output fluorescent optical signal **802**, and is properly suited for the desired application or experiment, e.g., temperature range, harsh chemicals, or other application specific requirements.

[0076] The code signal **822** from the bead code reader **820** and the fluorescent signal **810** from the fluorescence detector are provided to a known computer **812**. The computer reads the code associated with each bead and determines the chemical probe that was attached thereto from a predetermined table that correlates a predetermined relationship between the bead code and the attached probe. In addition, the computer **812** reads the fluorescence associated with each bead and determines the sample or analyte that is attached to the bead from a predetermined table that correlates a predetermined relationship between the fluorescence tag and the analyte attached thereto. The computer **812** then determines information about the analyte and/or the probe as well as about the bonding of the analyte to the probe, and provides such information on a display, printout, storage medium or other interface to an operator, scientist or database for review and/or analysis. The sources **801**, **803** the code reader **820**, the fluorescence optics **804** and detector **808** and the computer **812** may all be part of an assay stick reader **824**.

[0077] Alternatively, instead of having the code excitation source **801** and the fluorescence excitation source **803**, the reader **24** may have only one source beam which provides both the reflected optical signal **27** for determining the code and the fluorescence signal **802** for reading the tagged analyte attached to the beads **8**. In that case the input optical signal is a common wavelength that performs both functions simultaneously, or sequentially, if desired.

[0078] Generally, the assay of the present invention may be used to carry out any binding assay or screen involving immobilization of one of the binding agents. Such solid-phase assays or screens are well known in the chemical and biochemical arts. For example, such screening may involve specific binding of cells to a molecule (e.g. an antibody or antigen) immobilized on a microbead in the assay stick followed by analysis to detect whether or to what extent binding occurs. Alternatively, the beads may subsequently be removed from the assay stick for sorting and analysis via flow cytometry (see e.g. by Needels et al. (1993)). Examples of biological compounds that may be assayed or screened using the assay stick of the present invention include, e.g. agonists and antagonists for cell membrane receptors, toxins, venoms, viral epitopes, hormones, sugars, cofactors, peptides, enzyme substrates, drugs inclusive of opiates and steroids, proteins including antibodies, monoclonal antibodies, antisera reactive with specific antigenic determinants, nucleic acids, lectins, polysaccharides, cellular membranes and organelles. In addition, the present invention may be used in any of a large number of well-known hybridization assays where nucleic acids are immobilized on a surface of a substrate, e.g. genotyping, polymorphism detection, gene expression analysis, fingerprinting, and other methods of DNA- or RNA-based sample analysis or diagnosis.

[0079] Any of the great number of isotopic and non-isotopic labeling and detection methods well-known in the chemical and biochemical assay art may be used to detect binding with the present invention. Alternatively, spectroscopic methods well-known in the art may be used to determine directly whether a molecule is bound to a surface coating in a desired configuration. Spectroscopic methods include e.g., UV-VIS, NMR, EPR, IR, Raman, mass spectrometry and other methods well-known in the art. For example, mass spectrometry also is now widely employed for the analysis of biological macromolecules. The method

typically involves immobilization of a protein on a surface of substrate where it is then exposed to a ligand binding interaction. Following ligand binding (or non-binding) the molecule is desorbed from the surface and into a spectrometer using a laser (see, e.g. Merchant and Weinberger, "Recent advancements in surface-enhanced laser desorption/ionization-time of flight-mass spectrometry," *Electrophoresis* 21: 1164-1177 (2000)). The microbeads in the assay stick of the present invention may be used as substrates in the mass spectrometry detection methods described above.

**[0080]** Various aspects of the present invention may be conducted in an automated or semi-automated manner, generally with the assistance of well-known data processing methods. Computer programs and other data processing methods well known in the art may be used to store information including e.g. microbead identifiers, probe sequence information, sample information, and binding signal intensities. Data processing methods well known in the art may be used to read input data covering the desired characteristics.

**[0081]** The invention may be used in many areas such as drug discovery, functionalized substrates, biology, proteomics, combinatorial chemistry, DNA analysis/tracking/sorting/tagging, as well as tagging of molecules, biological particles, matrix support materials, immunoassays, receptor binding assays, scintillation proximity assays, radioactive or non-radioactive proximity assays, and other assays, (including fluorescent, mass spectroscopy), high throughput drug/genome screening, and/or massively parallel assay applications. The invention provides uniquely identifiable beads with reaction supports by active coatings for reaction tracking to perform multiplexed experiments.

**[0082]** Some current techniques used in combinatorial chemistry or biochemistry are described in U.S. Pat. No. 6,294,327, entitled "Apparatus and Method for Detecting Samples Labeled With Material Having Strong Light Scattering Properties, Using Reflection Mode Light and Diffuse Scattering", issued Sep. 23, 2001 to Walton et al.; U.S. Pat. No. 6,242,180, entitled "Computer Aided Visualization and Analysis System for Sequence Evaluation", issued Jun. 5, 2001, to Chee; U.S. Pat. No. 6,309,823 entitled "Arrays of Nucleic Acid Probes for Analyzing Biotransformation of Genes and Methods of Using the Same", Oct. 30, 2001, to Cronin et al.; U.S. Pat. No. 6,440,667, entitled "Analysis of Target Molecules Using an Encoding System"; U.S. Pat. No. 6,355,432, entitled "Products for Detecting Nucleic Acids"; U.S. Pat. No. 6,197,506, entitled "Method of Detecting Nucleic Acids"; U.S. Pat. No. 6,309,822, entitled "Method for comparing copy number of nucleic acid sequences"; U.S. Pat. No. 5,547,839, entitled "Sequencing of surface immobilized polymers utilizing micro-fluorescence detection", U.S. Pat. No. 6,383,754, entitled "Binary Encoded Sequence Tags", and U.S. Pat. No. 6,383,754, entitled "Fixed Address Analysis of Sequence Tags", which are all incorporated herein by reference to the extent needed to understand the present invention.

**[0083]** The invention can be used in combinatorial chemistry, active coating and functionalized polymers, as well as immunoassays, and hybridization reactions. The invention enables millions of parallel chemical reactions, enable large-scale repeated chemical reactions, increase productivity and reduce time-to-market for drug and other material development industries.

**[0084]** As discussed hereinbefore, although a fluorescent label is probably most convenient, other sorts of labels, e.g., radioactive, enzyme linked, optically detectable, or spectroscopic labels may be used. An appropriate detection method applicable to the selected labeling method can be selected. Suitable labels include radionucleotides, enzymes, substrates, cofactors, inhibitors, magnetic particles, heavy metal atoms, and particularly fluorescers, chemiluminescers, and spectroscopic labels. Patents teaching the use of such labels include U.S. Pat. Nos. 3,817,837; 3,850,752; 3,939,350; 3,996,345; 4,277,437; 4,275,149; and 4,366,241.

**[0085]** With an appropriate label selected, the detection system best adapted for high resolution and high sensitivity detection may be selected. As indicated above, an optically detectable system, e.g., fluorescence or chemiluminescence would be preferred but is not required. Other detection systems may be adapted to the purpose, e.g., electron microscopy, scanning electron microscopy (SEM), scanning tunneling electron microscopy (STEM), infrared microscopy, atomic force microscopy (AFM), electrical conductance, and image plate transfer.

**[0086]** Referring to FIG. 10, The reflected light 27, comprises a plurality of beams 26-36 that pass through a lens 37, which provides focused light beams 46-56, respectively, which are imaged onto a CCD camera 60. The lens 37 and the camera 60, and any other necessary electronics or optics for performing the functions described herein, make up the reader 29. Instead of or in addition to the lens 37, other imaging optics may be used to provide the desired characteristics of the optical image/signal onto the camera 60 (e.g., spots, lines, circles, ovals, etc.), depending on the shape of the substrate 10 and input optical signals. Also, instead of a CCD camera other devices may be used to read/capture the output light.

**[0087]** Referring to FIG. 11, the image on the CCD camera 60 is a series of illuminated stripes indicating ones and zeros of a digital pattern or code of the grating 12 in the element 8. Referring to FIG. 12, lines 68 on a graph 70 are indicative of a digitized version of the image of FIG. 11 as indicated in spatial periods ( $\Lambda 1-\Lambda n$ ).

**[0088]** Each of the individual spatial periods ( $\Lambda 1-\Lambda n$ ) in the grating 12 is slightly different, thus producing an array of N unique diffraction conditions (or diffraction angles) discussed more hereinafter. When the element 8 is illuminated from the side, in the region of the grating 12, at an appropriate input angle, e.g., about 30 degrees, with a single input wavelength  $\lambda$  (monochromatic) source, the diffracted (or reflected) beams 26-36 are generated. Other input angles  $\theta_i$  may be used if desired, depending on various design parameters as discussed herein and/or in the aforementioned patent application, and provided that a known diffraction equation (Eq. 1 below) is satisfied:

$$\sin(\theta_i) + \sin(\theta_o) = m\lambda/n\Lambda \quad \text{Eq. 1}$$

where Eq. 1 is diffraction (or reflection or scatter) relationship between input wavelength  $\lambda$ , input incident angle  $\theta_i$ , output incident angle  $\theta_o$ , and the spatial period  $\Lambda$  of the grating 12. Further, m is the "order" of the reflection being observed, and n is the refractive index of the substrate 10. The value of m=1 or first order reflection is acceptable for illustrative purposes. Eq. 1 applies to light incident on outer surfaces of the substrate 10 which are parallel to the longitudinal axis of the grating (or the  $k_B$  vector). Because the angles  $\theta_i, \theta_o$  are defined outside the substrate 10 and because

the effective refractive index of the substrate **10** is substantially a common value, the value of n in Eq. 1 cancels out of this equation.

**[0089]** Thus, for a given input wavelength  $\lambda$ , grating spacing  $\Lambda$ , and incident angle of the input light  $\theta_i$ , the angle  $\theta_o$  of the reflected output light may be determined. Solving Eq. 1 for  $\theta_o$  and plugging in  $m=1$ , gives:

$$\theta_o = \sin^{-1}(\lambda/\Lambda - \sin(\theta_i)) \quad \text{Eq. 2}$$

For example, for an input wavelength  $\lambda=532$  nm, a grating spacing  $\Lambda=0.532$  microns (or 532 nm), and an input angle of incidence  $\theta_i=30$  degrees, the output angle of reflection will be  $\theta_o=30$  degrees. Alternatively, for an input wavelength  $\lambda=632$  nm, a grating spacing  $\Lambda=0.532$  microns (or 532 nm), and an input angle  $\theta_i$  of 30 degrees, the output angle of reflection  $\theta_o$  will be at 43.47 degrees, or for an input angle  $\theta_i=37$  degrees, the output angle of reflection will be  $\theta_o=37$  degrees. Any input angle that satisfies the design requirements discussed herein and/or in the aforementioned patent application may be used.

**[0090]** In addition, to have sufficient optical output power and signal to noise ratio, the output light **27** should fall within an acceptable portion of the Bragg envelope (or normalized reflection efficiency envelope) curve **200**, as indicated by points **204,206**, also defined as a Bragg envelope angle  $\theta_B$ , as also discussed herein and/or in the aforementioned patent application. The curve **200** may be defined as:

$$I(ki, ko) \approx [KD]^2 \text{sinc}^2 \left[ \frac{(ki - ko)D}{2} \right] \quad \text{Eq. 3}$$

where  $K=2\pi\delta n/\lambda$ , where,  $\delta n$  is the local refractive index modulation amplitude of the grating and  $\lambda$  is the input wavelength,  $\text{sinc}(x)=\sin(x)/x$ , and the vectors  $k_i=2\pi \cos(\theta_i)/\lambda$  and  $k_o=2\pi \cos(\theta_o)/\lambda$  are the projections of the incident light and the output (or reflected) light, respectively, onto the line **203** normal to the axial direction of the grating **12** (or the grating vector  $k_B$ ),  $D$  is the thickness or depth of the grating **12** as measured along the line **203** (normal to the axial direction of the grating **12**). Other substrate shapes than a cylinder may be used and will exhibit a similar peaked characteristic of the Bragg envelope. We have found that a value for  $\delta n$  of about  $10^{-4}$  in the grating region of the substrate is acceptable; however, other values may be used if desired.

**[0091]** Rewriting Eq. 3 gives the reflection efficiency profile of the Bragg envelope as:

$$I(ki, ko) \approx \left[ \frac{2\pi \cdot \delta n \cdot D}{\lambda} \right]^2 \left[ \frac{\text{Sin}(x)}{x} \right]^2 \quad \text{Eq. 4}$$

where:

$$x=(ki-ko)D/2=(\pi D/\lambda) * (\cos \theta_i - \cos \theta_o)$$

**[0092]** Thus, when the input angle  $\theta_i$  is equal to the output (or reflected) angle  $\theta_o$  (i.e.,  $\theta_i=\theta_o$ ), the reflection efficiency  $I$  (Eqs. 3 & 4) is maximized, which is at the center or peak of the Bragg envelope. When  $\theta_i=\theta_o$ , the input light angle is referred to as the Bragg angle as is known. The efficiency decreases for other input and output angles (i.e.,  $\theta_i \neq \theta_o$ ), as

defined by Eqs. 3 & 4. Thus, for maximum reflection efficiency and thus output light power, for a given grating pitch  $\Lambda$  and input wavelength, the angle  $\theta_i$  of the input light **24** should be set so that the angle  $\theta_o$  of the reflected output light equals the input angle  $\theta_i$ .

**[0093]** Also, as the thickness or diameter  $D$  of the grating decreases, the width of the  $\text{sinc}(x)/x$  function (and thus the width of the Bragg envelope) increases and, the coefficient to or amplitude of the  $\text{sinc}^2$  (or  $(\text{sinc}(x)/x)^2$  function (and thus the efficiency level across the Bragg envelope) also increases, and vice versa. Further, as the wavelength  $\lambda$  increases, the half-width of the Bragg envelope as well as the efficiency level across the Bragg envelope both decrease. Thus, there is a trade-off between the brightness of an individual bit and the number of bits available under the Bragg envelope. Ideally,  $\delta n$  should be made as large as possible to maximize the brightness, which allows  $D$  to be made smaller.

**[0094]** From Eq. 3 and 4, the half-angle of the Bragg envelope  $\theta_B$  is defined as:

$$\theta_B = \frac{\eta\lambda}{\pi D \sin(\theta_i)} \quad \text{Eq. 5}$$

**[0095]** where  $\eta$  is a reflection efficiency factor which is the value for  $x$  in the  $\text{sinc}^2(x)$  function where the value of  $\text{sinc}^2(x)$  has decreased to a predetermined value from the maximum amplitude as indicated by points **204,206** on the curve **200**.

**[0096]** We have found that the reflection efficiency is acceptable when  $\eta \leq 1.39$ . This value for  $\eta$  corresponds to when the amplitude of the reflected beam (i.e., from the  $\text{sinc}^2(x)$  function of Eqs. 3 & 4) has decayed to about 50% of its peak value. In particular, when  $x=1.39=\eta$ ,  $\text{sinc}^2(x)=0.5$ . However, other values for efficiency thresholds or factor in the Bragg envelope may be used if desired.

**[0097]** The beams **26-36** are imaged onto the CCD camera **60** to produce the pattern of light and dark regions **120-132** representing a digital (or binary) code, where light=1 and dark=0 (or vice versa). The digital code may be generated by selectively creating individual index variations (or individual gratings) with the desired spatial periods  $\Lambda_1-\Lambda_n$ . Other illumination, readout techniques, types of gratings, geometries, materials, etc. may be used as discussed in the aforementioned patent application.

**[0098]** Referring to FIG. **13**, illustrations (a)-(c), for the grating **12** in a cylindrical substrate **10** having a sample spectral 17 bit code (i.e., 17 different pitches  $\Lambda_1-\Lambda_{17}$ ), the corresponding image on the CCD (Charge Coupled Device) camera **60** is shown for a digital pattern of 7 bits turned on (10110010001001001); 9 bits turned on of (11000101010100111); all 17 bits turned on of (11111111111111111).

**[0099]** For the images in FIG. **13**, the length of the substrate **10** was 450 microns, the outer diameter  $D_1$  was 65 microns, the inner diameter  $D$  was 14 microns,  $\delta n$  for the grating **12** was about  $10^{-4}$ ,  $n_1$  in portion **20** was about 1.458 (at a wavelength of about 1550 nm),  $n_2$  in portion **18** was about 1.453, the average pitch spacing  $\Lambda$  for the grating **12** was about 0.542 microns, and the spacing between pitches  $\Delta\Lambda$  was about 0.36% of the adjacent pitches  $\Lambda$ .

**[0100]** Referring to FIG. **14**, illustration (a), the pitch  $\Lambda$  of an individual grating is the axial spatial period of the

sinusoidal variation in the refractive index  $n_1$  in the region **20** of the substrate **10** along the axial length of the grating **12** as indicated by a curve **90** on a graph **91**. Referring to FIG. **14**, illustration (b), a sample composite grating **12** comprises three individual gratings that are co-located on the substrate **10**, each individual grating having slightly different pitches,  $\Lambda_1$ ,  $\Lambda_2$ ,  $\Lambda_3$ , respectively, and the difference (or spacing)  $\Delta\Lambda$  between each pitch  $\Lambda$  being about 3.0% of the period of an adjacent pitch  $\Lambda$  as indicated by a series of curves **92** on a graph **94**. Referring to FIG. **14**, illustration (c), three individual gratings, each having slightly different pitches,  $\Lambda_1$ ,  $\Lambda_2$ ,  $\Lambda_3$ , respectively, are shown, the difference  $\Delta\Lambda$  between each pitch  $\Lambda$  being about 0.3% of the pitch  $\Lambda$  of the adjacent pitch as shown by a series of curves **95** on a graph **97**. The individual gratings in FIG. **14**, illustrations (b) and (c) are shown to all start at 0 for illustration purposes; however, it should be understood that, the separate gratings need not all start in phase with each other. Referring to FIG. **14**, illustration (d), the overlapping of the individual sinusoidal refractive index variation pitches  $\Lambda_1$ - $\Lambda_n$  in the grating region **20** of the substrate **10**, produces a combined resultant refractive index variation in the composite grating **12** shown as a curve **96** on a graph **98** representing the combination of the three pitches shown in FIG. **14**, illustration (b). Accordingly, the resultant refractive index variation in the grating region **20** of the substrate **10** may not be sinusoidal and is a combination of the individual pitches  $\Lambda$  (or index variation).

**[0101]** The maximum number of resolvable bits  $N$ , which is equal to the number of different grating pitches  $\Lambda$  (and hence the number of codes), that can be accurately read (or resolved) using side-illumination and side-reading of the grating **12** in the substrate **10**, is determined by numerous factors, including: the beam width  $w$  incident on the substrate (and the corresponding substrate length  $L$  and grating length  $L_g$ ), the thickness or diameter  $D$  of the grating **12**, the wavelength  $\lambda$  of incident light, the beam divergence angle  $\theta_R$ , and the width of the Bragg envelope  $\theta_B$  (discussed more in the aforementioned patent application), and may be determined by the equation:

$$N \cong \frac{\eta\beta L}{2D\sin(\theta_i)} \quad \text{Eq. 6}$$

**[0102]** Referring to FIG. **15**, instead of having the input light **24** at a single wavelength  $\lambda$  (monochromatic) and reading the bits by the angle  $\theta_0$  of the output light, the bits (or grating pitches  $\Lambda$ ) may be read/detected by providing a plurality of wavelengths and reading the wavelength spectrum of the reflected output light signal. In this case, there would be one bit per wavelength, and thus, the code is contained in the wavelength information of the reflected output signal.

**[0103]** In this case, each bit (or  $\Lambda$ ) is defined by whether its corresponding wavelength falls within the Bragg envelope, not by its angular position within the Bragg envelope **200**. As a result, it is not limited by the number of angles that can fit in the Bragg envelope **200** for a given composite grating **12**, as in the embodiment discussed hereinbefore. Thus, using multiple wavelengths, the only limitation in the number of bits  $N$  is the maximum number of grating pitches  $\Lambda$  that can be superimposed and optically distinguished in wavelength space for the output beam.

**[0104]** Referring to FIGS. **15** and **16**, illustration (a), the reflection wavelength spectrum ( $\lambda_1$ - $\lambda_n$ ) of the reflected output beam **310** will exhibit a series of reflection peaks **695**, each appearing at the same output Bragg angle  $\theta_0$ . Each wavelength peak **695** ( $\lambda_1$ - $\lambda_n$ ) corresponds to an associated spatial period ( $\Lambda_1$ - $\Lambda_n$ ), which make up the grating **12**.

**[0105]** One way to measure the bits in wavelength space is to have the input light angle  $\theta_i$  equal to the output light angle  $\theta_0$ , which is kept at a constant value, and to provide an input wavelength  $\lambda$  that satisfies the diffraction condition (Eq. 1) for each grating pitch  $\Lambda$ . This will maximize the optical power of the output signal for each pitch  $\Lambda$  detected in the grating **12**.

**[0106]** Referring to **16**, illustration (b), the transmission wavelength spectrum of the transmitted output beam **330** (which is transmitted straight through the grating **12**) will exhibit a series of notches (or dark spots) **696**. Alternatively, instead of detecting the reflected output light **310**, the transmitted light **330** may be detected at the detector/reader **308**. It should be understood that the optical signal levels for the reflection peaks **695** and transmission notches **696** will depend on the "strength" of the grating **12**, i.e., the magnitude of the index variation  $n$  in the grating **12**.

**[0107]** In FIG. **15**, the bits may be detected by continuously scanning the input wavelength. A known optical source **300** provides the input light signal **24** of a coherent scanned wavelength input light shown as a graph **304**. The source **300** provides a sync signal on a line **306** to a known reader **308**. The sync signal may be a timed pulse or a voltage ramped signal, which is indicative of the wavelength being provided as the input light **24** to the substrate **10** at any given time. The reader **308** may be a photodiode, CCD camera, or other optical detection device that detects when an optical signal is present and provides an output signal on a line **309** indicative of the code in the substrate **10** or of the wavelengths present in the output light, which is directly related to the code, as discussed herein. The grating **12** reflects the input light **24** and provides an output light signal **310** to the reader **308**. The wavelength of the input signal is set such that the reflected output light **310** will be substantially in the center **314** of the Bragg envelope **200** for the individual grating pitch (or bit) being read.

**[0108]** Alternatively, the source **300** may provide a continuous broadband wavelength input signal such as that shown as a graph **316**. In that case, the reflected output beam **310** signal is provided to a narrow band scanning filter **318** which scans across the desired range of wavelengths and provides a filtered output optical signal **320** to the reader **308**. The filter **318** provides a sync signal on a line **322** to the reader, which is indicative of which wavelengths are being provided on the output signal **320** to the reader and may be similar to the sync signal discussed hereinbefore on the line **306** from the source **300**. In this case, the source **300** does not need to provide a sync signal because the input optical signal **24** is continuous. Alternatively, instead of having the scanning filter being located in the path of the output beam **310**, the scanning filter may be located in the path of the input beam **24** as indicated by the dashed box **324**, which provides the sync signal on a line **323**.

**[0109]** Alternatively, instead of the scanning filters **318**, **324**, the reader **308** may be a known optical spectrometer (such as a known spectrum analyzer), capable of measuring the wavelength of the output light.



**[0110]** The desired values for the input wavelengths  $\lambda$  (or wavelength range) for the input signal **24** from the source **300** may be determined from the Bragg condition of Eq. 1, for a given grating spacing  $\Lambda$  and equal angles for the input light  $\theta_i$  and the angle light  $\theta_o$ . Solving Eq. 1 for  $\lambda$  and plugging in  $m=1$ , gives:

$$\lambda = \Lambda [\sin(\theta_o) + \sin(\theta_i)] \quad \text{Eq. 7}$$

**[0111]** It is also possible to combine the angular-based code detection with the wavelength-based code detection, both discussed hereinbefore. In this case, each readout wavelength is associated with a predetermined number of bits within the Bragg envelope. Bits (or grating pitches  $\Lambda$ ) written for different wavelengths do not show up unless the correct wavelength is used.

**[0112]** Accordingly, the bits (or grating pitches  $\Lambda$ ) can be read using one wavelength and many angles, many wavelengths and one angle, or many wavelengths and many angles.

**[0113]** Referring to FIG. 17, the grating **12** may have a thickness or depth  $D$  which is comparable or smaller than the incident beam wavelength  $\lambda$ . This is known as a “thin” diffraction grating (or the full angle Bragg envelope is 180 degrees). In that case, the half-angle Bragg envelope  $\theta_B$  is substantially 90 degrees; however,  $\delta n$  must be made large enough to provide sufficient reflection efficiency, per Eqs. 3 and 4. In particular, for a “thin” grating,  $D \cdot \delta n \approx \lambda/2$ , which corresponds to a  $\pi$  phase shift between adjacent minimum and maximum refractive index values of the grating **12**.

**[0114]** It should be understood that there is still a trade-off discussed hereinbefore with beam divergence angle  $\theta_R$  and the incident beam width (or length  $L$  of the substrate), but the accessible angular space is theoretically now 90 degrees. Also, for maximum efficiency, the phase shift between adjacent minimum and maximum refractive index values of the grating **12** should approach a  $\pi$  phase shift; however, other phase shifts may be used.

**[0115]** In this case, rather than having the input light **24** coming in at the conventional Bragg input angle  $\theta_i$ , as discussed hereinbefore and indicated by a dashed line **701**, the grating **12** is illuminated with the input light **24** oriented on a line **705** orthogonal to the longitudinal grating vector **705**. The input beam **24** will split into two (or more) beams of equal amplitude, where the exit angle  $\theta_o$  can be determined from Eq. 1 with the input angle  $\theta_i=0$  (normal to the longitudinal axis of the grating **12**).

**[0116]** In particular, from Eq. 1, for a given grating pitch  $\Lambda_1$ , the  $+/-1^{st}$  order beams ( $m=+1$  and  $m=-1$ ), corresponds to output beams **700,702**, respectively. For the  $+/-2^{nd}$  order beams ( $m=+2$  and  $m=-2$ ), corresponds to output beams **704,706**, respectively. The  $0^{th}$  order (undefracted) beam ( $m=0$ ), corresponds to beam **708** and passes straight through the substrate. The output beams **700-708** project spectral spots or peaks **710-718**, respectively, along a common plane, shown from the side by a line **709**, which is parallel to the upper surface of the substrate **10**.

**[0117]** For example, for a grating pitch  $\Lambda=1.0$   $\mu\text{m}$ , and an input wavelength  $\lambda=400$  nm, the exit angles  $\theta_o$  are  $\sim +/-23.6$  degrees (for  $m=+/-1$ ), and  $\sim +/-53.1$  degrees (from  $m=+/-2$ ), from Eq. 1. It should be understood that for certain wavelengths, certain orders (e.g.,  $m=+/-2$ ) may be reflected back toward the input side or otherwise not detectable at the output side of the grating **12**.

**[0118]** Alternatively, one can use only the  $+/-1^{st}$  order ( $m=+/-1$ ) output beams for the code, in which case there would be only 2 peaks to detect, **712, 714**. Alternatively, one can also use any one or more pairs from any order output beam that is capable of being detected. Alternatively, instead of using a pair of output peaks for a given order, an individual peak may be used.

**[0119]** Referring to FIG. 18, if two pitches  $\Lambda_1, \Lambda_2$  exist in the grating **12**, two sets of peaks will exist. In particular, for a second grating pitch  $\Lambda_2$ , the  $+/-1^{st}$  order beams ( $m=+1$  and  $m=-1$ ), corresponds to output beams **720,722**, respectively. For the  $+/-2^{nd}$  order beams ( $m=+2$  and  $m=-2$ ), corresponds to output beams **724,726**, respectively. The  $0^{th}$  order (undefracted) beam ( $m=0$ ), corresponds to beam **718** and passes straight through the substrate. The output beams **720-726** corresponding to the second pitch  $\Lambda_2$  project spectral spots or peaks **730-736**, respectively, which are at a different location than the point **710-716**, but along the same common plane, shown from the side by the line **709**.

**[0120]** Thus, for a given pitch  $\Lambda$  (or bit) in a grating, a set of spectral peaks will appear at a specific location in space. Thus, each different pitch corresponds to a different elevation or output angle which corresponds to a predetermined set of spectral peaks. Accordingly, the presence or absence of a particular peak or set of spectral peaks defines the code.

**[0121]** In general, if the angle of the grating **12** is not properly aligned with respect to the mechanical longitudinal axis of the substrate **10**, the readout angles may no longer be symmetric, leading to possible difficulties in readout. With a thin grating, the angular sensitivity to the alignment of the longitudinal axis of the substrate **10** to the input angle  $\theta_i$  of incident radiation is reduced or eliminated. In particular, the input light can be oriented along substantially any angle  $\theta_i$  with respect to the grating **12** without causing output signal degradation, due the large Bragg angle envelope. Also, if the incident beam **24** is normal to the substrate **10**, the grating **12** can be oriented at any rotational (or azimuthal) angle without causing output signal degradation. However, in each of these cases, changing the incident angle  $\theta_i$  will affect the output angle  $\theta_o$  of the reflected light in a predetermined predictable way, thereby allowing for accurate output code signal detection or compensation.

**[0122]** Referring to FIG. 19, for a thin grating, in addition to multiplexing in the elevation or output angle based on grating pitch  $\Lambda$ , the bits can also be multiplexed in an azimuthal (or rotational) angle  $\theta_a$  of the substrate. In particular, a plurality of gratings **750,752,754,756** each having the same pitch  $\Lambda$  are disposed in a surface **701** of the substrate **10** and located in the plane of the substrate surface **701**. The input light **24** is incident on all the gratings **750,752,754,756** simultaneously. Each of the gratings provides output beams oriented based on the grating orientation. For example, the grating **750** provides the output beams **764,762**, the grating **752** provides the output beams **766,768**, the grating **754** provides the output beams **770,772**, and the grating **756** provides the output beams **774,776**. Each of the output beams provides spectral peaks or spots (similar to that discussed hereinbefore), which are located in a plane **760** that is parallel to the substrate surface plane **701**. In this case, a single grating pitch  $\Lambda$  can produce many bits depending on the number of gratings that can be placed at different azimuthal (rotational) angles on the surface of the substrate **10** and the number of output beam spectral peaks that can be spatially and optically resolved/detected. Each bit may be

viewed as the presence or absence of a pair of peaks located at a predetermined location in space in the plane 760. Note that this example uses only the  $m=+/-1^{st}$  order for each reflected output beam. Alternatively, the detection may also use the  $m=+/-2^{nd}$  order. In that case, there would be two additional output beams and peaks (not shown) for each grating (as discussed hereinbefore) that may lie in the same plane as the plane 760 and may be on a concentric circle outside the circle 760.

[0123] In addition, the azimuthal multiplexing can be combined with the elevation or output angle multiplexing discussed hereinbefore to provide two levels of multiplexing. Accordingly, for a thin grating, the number of bits can be multiplexed based on the number of grating pitches  $\Lambda$  and/or geometrically by the orientation of the grating pitches.

[0124] Furthermore, if the input light angle  $\theta_i$  is normal to the substrate 10, the edges of the substrate 10 no longer scatter light from the incident angle into the “code angular space”, as discussed herein and/or in the aforementioned patent application.

[0125] Also, in the thin grating geometry, a continuous broadband wavelength source may be used as the optical source if desired.

[0126] Referring to FIG. 20, instead of or in addition to the pitches  $\Lambda$  in the grating 12 being oriented normal to the longitudinal axis, the pitches may be created at an angle  $\theta_g$ . In that case, when the input light 24 is incident normal to the surface 792, will produce a reflected output beam 790 having an angle  $\theta_o$  determined by Eq. 1 as adjusted for the blaze angle  $\theta_g$ . This can provide another level of multiplexing bits in the code.

[0127] Referring to FIG. 21, instead of using an optical binary (0-1) code, an additional level of multiplexing may be provided by having the optical code use other numerical bases, if intensity levels of each bit are used to indicate code information. This could be achieved by having a corresponding magnitude (or strength) of the refractive index change ( $\delta n$ ) for each grating pitch  $\Lambda$ . Four intensity ranges are shown for each bit number or pitch  $\Lambda$ , providing for a Base-4 code (where each bit corresponds to 0, 1, 2, or 3). The lowest intensity level, corresponding to a 0, would exist when this pitch  $\Lambda$  is not present in the grating 12. The next intensity level 450 would occur when a first low level  $\delta n_1$  exists in the grating that provides an output signal within the intensity range corresponding to a 1. The next intensity level 452 would occur when a second higher level  $\delta n_2$  exists in the grating 12 that provides an output signal within the intensity range corresponding to a 2. The next intensity level 452, would occur when a third higher level  $\delta n_3$  exists in the grating 12 that provides an output signal within the intensity range corresponding to a 3.

[0128] Referring to FIG. 22, the input light 24 may be incident on the substrate 10 on an end face 600 of the substrate 10. In that case, the input light 24 will be incident on the grating 12 having a more significant component of the light (as compared to side illumination discussed hereinbefore) along the longitudinal grating axis 207 of the grating (along the grating vector  $k_B$ ), as shown by a line 602. The light 602 reflects off the grating 12 as indicated by a line 604 and exits the substrate as output light 608. Accordingly, it should be understood by one skilled in the art that the diffraction equations discussed hereinbefore regarding output diffraction angle  $\theta_o$  also apply in this case except that the

reference axis would now be the grating axis 207. Thus, in this case, the input and output light angles  $\theta_i, \theta_o$ , would be measured from the grating axis 207 and length  $L_g$  of the grating 12 would become the thickness or depth  $D$  of the grating 12. As a result, a grating 12 that is 400 microns long, would result in the Bragg envelope 200 being narrow. It should be understood that because the values of  $n_1$  and  $n_2$  are close to the same value, the slight angle changes of the light between the regions 18,20 are not shown herein.

[0129] In the case where incident light 610 is incident along the same direction as the grating vector ( $K_B$ ) 207, i.e.,  $\theta_i=0$  degrees, the incident light sees the whole length  $L_g$  of the grating 12 and the grating provides a reflected output light angle  $\theta_o=0$  degrees, and the Bragg envelope 612 becomes extremely narrow, as the narrowing effect discussed above reaches a limit. In that case, the relationship between a given pitch  $\Lambda$  in the grating 12 and the wavelength of reflection  $X$  is governed by a known “Bragg grating” relation:

$$\lambda = 2n_{eff}\Lambda \quad \text{Eq. 8}$$

where  $n_{eff}$  is the effective index of refraction of the substrate,  $\lambda$  is the input (and output wavelength) and  $\Lambda$  is the pitch. This relation, as is known, may be derived from Eq. 1 where  $\theta_i=\theta_o=90$  degrees.

[0130] In that case, the code information is readable only in the spectral wavelength of the reflected beam, similar to that discussed hereinbefore for wavelength based code reading. Accordingly, the input signal in this case may be a scanned wavelength source or a broadband wavelength source. In addition, as discussed hereinbefore for wavelength based code reading, the code information may be obtained in reflection from the reflected beam 614 or in transmission by the transmitted beam 616 that passes through the grating 12.

[0131] It should be understood that for shapes of the substrate 10 or element 8 other than a cylinder, the effect of various different shapes on the propagation of input light through the element 8, substrate 10, and/or grating 12, and the associated reflection angles, can be determined using known optical physics including Snell’s Law, shown below:

$$n_{in} \sin \theta_{in} = n_{out} \sin \theta_{out} \quad \text{Eq. 9}$$

[0132] where  $n_{in}$  is the refractive index of the first (input) medium, and  $n_{out}$  is the refractive index of the second (output) medium, and  $\theta_{in}$  and  $\theta_{out}$  are measured from a line 620 normal to an incident surface 622.

[0133] Referring to FIG. 23, if the value of  $n_1$  in the grating region 20 is greater than the value of  $n_2$  in the non-grating region 18, the grating region 20 of the substrate 10 will act as a known optical waveguide for certain wavelengths. In that case, the grating region 20 acts as a “core” along which light is guided and the outer region 18’ acts as a “cladding” which helps confine or guide the light. Also, such a waveguide will have a known “numerical aperture” ( $\theta_{na}$ ) that will allow light that is within the aperture  $\theta_{na}$  to be directed or guided along the grating axis 207 and reflected axially off the grating 12 and returned and guided along the waveguide. In that case, the grating 12 will reflect light having the appropriate wavelengths equal to the pitches  $\Lambda$  present in the grating 12 back along the region 20 (or core) of the waveguide, and pass the remaining wavelengths of light as the light 632. Thus, having the grating region 20 act as an optical waveguide for wavelengths reflected by the grating 12 allows incident light that is not

aligned exactly with the grating axis **207** to be guided along and aligned with the grating **12** axis **207** for optimal grating reflection.

**[0134]** If an optical waveguide is used any standard waveguide may be used, e.g., a standard telecommunication single mode optical fiber (125 micron diameter or 80 micron diameter fiber with about a 8-10 micron diameter), or a larger diameter waveguide (greater than 0.5 mm diameter), such as is describe in U.S. patent application Ser. No. 09/455,868, filed Dec. 6, 1999, entitled "Large Diameter Waveguide, Grating". Further, any type of optical waveguide may be used for the optical substrate **10**, such as, a multi-mode, birefringent, polarization maintaining, polarizing, multi-core, multi-cladding, or microstructured optical waveguide, or a flat or planar waveguide (where the waveguide is rectangular shaped), or other waveguides.

**[0135]** Referring to FIG. **24**, if the grating **12** extends across the entire dimension D of the substrate, the substrate **10** does not behave as a waveguide for the incident or reflected light and the incident light **24** will be diffracted (or reflected) as indicated by lines **642**, and the codes detected as discussed hereinbefore for the end-incidence condition discussed hereinbefore with FIG. **45**, and the remaining light **640** passes straight through.

**[0136]** Referring to FIG. **25**, illustrations (a)-(c), in illustration (a), for the end illumination condition, if a blazed or angled grating is used, as discussed hereinbefore, the input light **24** is coupled out of the substrate **10** at a known angle as shown by a line **650**. Referring to FIG. **25**, illustration (b), alternatively, the input light **24** may be incident from the side and, if the grating **12** has the appropriate blaze angle, the reflected light will exit from the end face **652** as indicated by a line **654**. Referring to FIG. **25**, illustration (c), the grating **12** may have a plurality of different pitch angles **660,662**, which reflect the input light **24** to different output angles as indicated by lines **664, 666**. This provides another level of multiplexing (spatially) additional codes, if desired.

**[0137]** The grating **12** may be impressed in the substrate **10** by any technique for writing, impressed, embedded, imprinted, or otherwise forming a diffraction grating in the volume of or on a surface of a substrate **10**. Examples of some known techniques are described in U.S. Pat. Nos. 4,725,110 and 4,807,950, entitled "Method for Impressing Gratings Within Fiber Optics", to Glenn et al; and U.S. Pat. No. 5,388,173, entitled "Method and Apparatus for Forming Aperiodic Gratings in Optical Fibers", to Glenn, respectively, and U.S. Pat. No. 5,367,588, entitled "Method of Fabricating Bragg Gratings Using a Silica Glass Phase Grating Mask and Mask Used by Same", to Hill, and U.S. Pat. No. 3,916,182, entitled "Periodic Dielectric Waveguide Filter", Dabby et al, and U.S. Pat. No. 3,891,302, entitled "Method of Filtering Modes in Optical Waveguides", to Dabby et al, which are all incorporated herein by reference to the extent necessary to understand the present invention.

**[0138]** Alternatively, instead of the grating **12** being impressed within the substrate material, the grating **12** may be partially or totally created by etching or otherwise altering the outer surface geometry of the substrate to create a corrugated or varying surface geometry of the substrate, such as is described in U.S. Pat. No. 3,891,302, entitled "Method of Filtering Modes in Optical Waveguides", to Dabby et al, which is incorporated herein by reference to the

extent necessary to understand the present invention, provided the resultant optical refractive profile for the desired code is created.

**[0139]** Further, alternatively, the grating **12** may be made by depositing dielectric layers onto the substrate, similar to the way a known thin film filter is created, so as to create the desired resultant optical refractive profile for the desired code.

**[0140]** The substrate **10** (and/or the element **8**) may have end-view cross-sectional shapes other than circular, such as square, rectangular, elliptical, clam-shell, D-shaped, or other shapes, and may have side-view sectional shapes other than rectangular, such as circular, square, elliptical, clam-shell, D-shaped, or other shapes. Also, 3D geometries other than a cylinder may be used, such as a sphere, a cube, a pyramid or any other 3D shape. Alternatively, the substrate **10** may have a geometry that is a combination of one or more of the foregoing shapes.

**[0141]** The shape of the element **8** and the size of the incident beam may be made to minimize any end scatter off the end face(s) of the element **8**, as is discussed herein and/or in the aforementioned patent application. Accordingly, to minimize such scatter, the incident beam **24** may be oval shaped where the narrow portion of the oval is smaller than the diameter D1, and the long portion of the oval is smaller than the length L of the element **8**. Alternatively, the shape of the end faces may be rounded or other shapes or may be coated with an antireflective coating.

**[0142]** It should be understood that the size of any given dimension for the region **20** of the grating **12** may be less than any corresponding dimension of the substrate **10**. For example, if the grating **12** has dimensions of length L<sub>g</sub>, depth D<sub>g</sub>, and width W<sub>g</sub>, and the substrate **12** has different dimensions of length L, depth D, and width W, the dimensions of the grating **12** may be less than that of the substrate **12**. Thus, the grating **12**, may be embedded within or part of a much larger substrate **12**. Also, the element **8** may be embedded or formed in or on a larger object for identification of the object.

**[0143]** The dimensions, geometries, materials, and material properties of the substrate **10** are selected such that the desired optical and material properties are met for a given application. The resolution and range for the optical codes are scalable by controlling these parameters as discussed herein and/or in the aforementioned patent application.

**[0144]** Referring to FIG. **26**, the substrate **10** may have an outer coating **799**, such as a polymer or other material that may be dissimilar to the material of the substrate **10**, provided that the coating **799** on at least a portion of the substrate, allows sufficient light to pass through the substrate for adequate optical detection of the code. The coating **799** may be on any one or more sides of the substrate **10**. Also, the coating **799** may be a material that causes the element **8** to float or sink in certain fluids (liquid and/or gas) solutions.

**[0145]** Also, the substrate **10** may be made of a material that is less dense than certain fluid (liquids and/or gas) solutions, thereby allowing the elements **8** to float or be buoyant or partially buoyant. Also, the substrate may be made of a porous material, such as controlled pore glass (CPG) or other porous material, which may also reduce the density of the element **8** and may make the element **8** buoyant or partially-buoyant in certain fluids.

**[0146]** Referring to FIG. **27**, the grating **12** is axially spatially invariant. As a result, the substrate **10** with the

grating 12 (shown as a long substrate 21) may be axially subdivided or cut into many separate smaller substrates 30-36 and each substrate 30-36 will contain the same code as the longer substrate 21 had before it was cut. The limit on the size of the smaller substrates 30-36 is based on design and performance factors discussed herein and/or in the aforementioned patent application.

[0147] Referring to FIG. 28, one purpose of the outer region 18 (or region without the grating 12) of the substrate 10 is to provide mechanical or structural support for the inner grating region 20. Accordingly, the entire substrate 10 may comprise the grating 12, if desired. Alternatively, the support portion may be completely or partially beneath, above, or along one or more sides of the grating region 20, such as in a planar geometry, or a D-shaped geometry, or other geometries, as described herein and/or in the aforementioned patent application. The non-grating portion 18 of the substrate 10 may be used for other purposes as well, such as optical lensing effects or other effects (discussed herein or in the aforementioned patent application). Also, the end faces of the substrate 10 need not be perpendicular to the sides or parallel to each other. However, for applications where the elements 8 are stacked end-to-end, the packing density may be optimized if the end faces are perpendicular to the sides.

[0148] Referring to FIG. 29, illustrations (a)-(c), two or more substrates 10,250, each having at least one grating therein, may be attached together to form the element 8, e.g., by an adhesive, fusing or other attachment techniques. In that case, the gratings 12,252 may have the same or different codes.

[0149] Referring to FIG. 30, illustrations (a) and (b), the substrate 10 may have multiple regions 80,90 and one or more of these regions may have gratings in them. For example, there may be gratings 12,252 side-by-side (illustration (a)), or there may be gratings 82-88, spaced end-to-end (illustration (b)) in the substrate 10.

[0150] Referring to FIG. 31, the length L of the element 8 may be shorter than its diameter D, thus, having a geometry such as a plug, puck, wafer, disc or plate.

[0151] Referring to FIG. 32, to facilitate proper alignment of the grating axis with the angle  $\theta_i$  of the input beam 24, the substrate 10 may have a plurality of the gratings 12 having the same codes written therein at numerous different angular or rotational (or azimuthal) positions of the substrate 10. In particular, two gratings 550, 552, having axial grating axes 551, 553, respectively may have a common central (or pivot or rotational) point where the two axes 551,553 intersect. The angle  $\theta_i$  of the incident light 24 is aligned properly with the grating 550 and is not aligned with the grating 552, such that output light 555 is reflected off the grating 550 and light 557 passes through the grating 550 as discussed herein. If the element 8 is rotated as shown by the arrows 559, the angle  $\theta_i$  of incident light 24 will become aligned properly with the grating 552 and not aligned with the grating 550 such that output light 555 is reflected off the grating 552 and light 557 passes through the grating 552. When multiple gratings are located in this rotational orientation, the bead may be rotated as indicated by a line 559 and there may be many angular positions that will provide correct (or optimal) incident input angles  $\theta_i$  to the grating. While this example shows a circular cross-section, this technique may be used with any shape cross-section.

[0152] Referring to FIG. 33, illustrations (a), (b), (c), (d), and (e) the substrate 10 may have one or more holes located within the substrate 10. In illustration (a), holes 560 may be located at various points along all or a portion of the length of the substrate 10. The holes need not pass all the way through the substrate 10. Any number, size and spacing for the holes 560 may be used if desired. In illustration (b), holes 572 may be located very close together to form a honeycomb-like area of all or a portion of the cross-section. In illustration (c), one (or more) inner hole 566 may be located in the center of the substrate 10 or anywhere inside of where the grating region(s) 20 are located. The inner hole 566 may be coated with a reflective coating 573 to reflect light to facilitate reading of one or more of the gratings 12 and/or to reflect light diffracted off one or more of the gratings 12. The incident light 24 may reflect off the grating 12 in the region 20 and then reflect off the surface 573 to provide output light 577. Alternatively, the incident light 24 may reflect off the surface 573, then reflect off the grating 12 and provide the output light 575. In that case the grating region 20 may run axially or circumferentially 571 around the substrate 10. In illustration (d), the holes 579 may be located circumferentially around the grating region 20 or transversely across the substrate 10. In illustration (e), the grating 12 may be located circumferentially around the outside of the substrate 10, and there may be holes 574 inside the substrate 10.

[0153] Referring to FIG. 34, illustrations (a), (b), and (c), the substrate 10 may have one or more protruding portions or teeth 570, 578,580 extending radially and/or circumferentially from the substrate 10. Alternatively, the teeth 570, 578,580 may have any other desired shape.

[0154] Referring to FIG. 35, illustrations (a), (b), (c) a D-shaped substrate, a flat-sided substrate and an eye-shaped (or clam-shell or teardrop shaped) substrate 10, respectively, are shown. Also, the grating region 20 may have end cross-sectional shapes other than circular and may have side cross-sectional shapes other than rectangular, such as any of the geometries described herein for the substrate 10. For example, the grating region 20 may have an oval cross-sectional shape as shown by dashed lines 581, which may be oriented in a desired direction, consistent with the teachings herein. Any other geometries for the substrate 10 or the grating region 20 may be used if desired, as described herein.

[0155] Referring to FIG. 36, at least a portion of a side of the substrate 10 may be coated with a reflective coating to allow incident light 510 to be reflected back to the same side from which the incident light came, as indicated by reflected light 512.

[0156] Referring to FIG. 37, illustrations (a) and (b), alternatively, the substrate 10 can be electrically and/or magnetically polarized, by a dopant or coating, which may be used to ease handling and/or alignment or orientation of the substrate 10 and/or the grating 12, or used for other purposes. Alternatively, the bead may be coated with conductive material, e.g., metal coating on the inside of a hollow substrate, or metallic dopant inside the substrate. In these cases, such materials can cause the substrate 10 to align in an electric or magnetic field. Alternatively, the substrate can be doped with an element or compound that fluoresces or glows under appropriate illumination, e.g., a rare earth dopant, such as Erbium, or other rare earth dopant or

fluorescent or luminescent molecule. In that case, such fluorescence or luminescence may aid in locating and/or aligning substrates.

[0157] The dimensions and geometries for any of the embodiments described herein are merely for illustrative purposes and, as such, any other dimensions may be used if desired, depending on the application, size, performance, manufacturing requirements, or other factors, in view of the teachings herein.

[0158] It should be understood that, unless stated otherwise herein, any of the features, characteristics, alternatives or modifications described regarding a particular embodiment herein may also be applied, used, or incorporated with any other embodiment described herein. Also, the drawings herein are not drawn to scale.

[0159] Although the invention has been described and illustrated with respect to exemplary embodiments thereof, the foregoing and various other additions and omissions may be made therein and thereto without departing from the spirit and scope of the present invention.

1-19. (canceled)

20. A method, comprising:

providing a particle having a grating disposed therein, the grating comprising a superposition of different predetermined regular periodic variations of an index of refraction disposed along a grating axis and indicative of a code;

directing an illuminating light beam at the particle other than along the grating axis and other than fully transverse to the grating axis;

reading the code by at least one of i) sensing light that is reflected by the grating and ii) sensing light transmitted through the grating;

determining which of the periodic variations are present; and

constructing a string of bits with each bit in the string predetermined to correspond to a particular one of the periodic variations, the bits being set so as to indicate whether the particular one of the periodic variations is present in the light reflected by the grating or the light transmitted through the grating.

21. A method as in claim 20, wherein the periodic variations are read using one wavelength for the illuminating light beam and observing the light reflected by the grating at a plurality of predetermined angles, or using many wavelengths and one angle, or using many wavelengths and many angles.

22. A method as in claim 20, wherein the reading includes both sensing light reflected by the grating and sensing light transmitted through the grating.

23. A method as in claim 20, wherein the particle has a particle substrate formed of a transparent dielectric material with the index of refraction at each point in the dielectric material, and the superposition of different regular periodic variations in the index of refraction is disposed along a length of the particle substrate.

24. A method as in claim 20, wherein the superposition is provided so as to correspond to a predetermined code for identifying the particle.

25. A method according to claim 23, wherein said particle substrate has an elongated shape and wherein said superposition of different regular periodic variations in the index of refraction occurs along a length of said particle substrate.

26. A method according to claim 25, wherein the code is readable based on the grating altering the transmitted light beam, wherein the light is transmitted through the particle substrate in a direction transverse to an elongated dimension of the particle substrate.

27. A method according to claim 20, wherein the superposition includes a combination of one or more individual sinusoidal spatial periods or pitches of refractive index variation along the particle.

28. A method according to claim 20, wherein at least a portion of said particle is made of a substantially single material and has at least one diffraction grating embedded therein.

29. A method according to claim 28, wherein said diffraction grating has a resultant refractive index variation within the single material at a grating location, said resultant refractive index variation comprising a plurality of refractive index pitches superimposed at said grating location.

30. A method according to claim 20, wherein the particle responds to the illuminating light beam, for providing a grating output optical signal that is a result of passive, non-resonant scattering from said grating when illuminated by said illuminating light beam.

31. A method according to claim 23, wherein said particle substrate is made of a material selected from the group: glass, silica, plastic, rubber, and polymer.

32. A method according to claim 24, wherein said predetermined code comprises a plurality of digital bits.

33. A method according to claim 24, wherein said predetermined code comprises at least 3 predetermined bits.

34. A method according to claim 24, wherein said predetermined code comprises at least 16 predetermined bits.

35. A method according to claim 24, wherein said predetermined code comprises a plurality of bits, each bit having a plurality of states.

36. A method according to claim 24, wherein said predetermined code comprises a plurality of bits, each bit having a corresponding spatial location and each bit in said predetermined code having a value related to an intensity of a grating output optical signal at the spatial location of each bit.

37. A method according to claim 36, wherein the value of each bit corresponds to a magnitude of refractive index variation of a corresponding refractive index pitch in said grating.

38. A method according to claim 23, wherein said particle substrate has a coating disposed on at least a portion of said particle substrate, at least a portion of said coating being made of a material that allows sufficient amount of the illuminating light beam to pass through said material to allow detection of said code.

39. A method according to claim 23, wherein at least a portion of said particle substrate has a 3-D shape selected from a group: a cylinder, a sphere, a cube, and a pyramid.

40. A method according to claim 23, wherein said particle substrate has a grating region where said grating is located and a non-grating region where said grating is not located; and wherein said particle substrate has a plurality of grating regions.

41. A method according to claim 20, wherein said grating is a thin grating or a blazed grating.

42. A method according to claim 23, wherein said particle substrate comprises a plurality of said gratings.

**43.** A method according to claim **23**, wherein said particle substrate comprises a plurality of said gratings each at different locations within said particle substrate.

**44.** A method according to claim **30**, wherein said light signal comprises laser light.

**45.** A method according to claim **23**, wherein said substrate is photosensitive at least at said grating location.

**46.** A method according to claim **20**, wherein said illuminating light beam comprises a substantially single wavelength.

**47.** A method according to claim **20**, wherein said illuminating light beam comprises a plurality of wavelengths or a single wavelength scanned over a predetermined wavelength range.

**48.** A method according to claim **23**, wherein said illuminating light beam is incident on said particle substrate along a longitudinal grating axis of said grating.

**49.** A method according to claim **23**, wherein said illuminating light beam is incident on said particle substrate at an angle to a longitudinal grating axis of said grating.

**50.** A method according to claim **23**, wherein a chemical is attached to at least a portion of the particle substrate.

**51.** A method according to claim **50**, wherein said chemical comprises at least one gene, oligonucleotide, protein, antibody, peptide, amino acid, NDA, cDNA, RNA, nucleic acid oligomer, polymer, or biological cell, or portion thereof.

\* \* \* \* \*