



(51) International Patent Classification:
A61B 34/10 (2016.01) A61B 34/20 (2016.01)

(21) International Application Number:
PCT/US2021/037580

(22) International Filing Date:
16 June 2021 (16.06.2021)

(25) Filing Language: English

(26) Publication Language: English

(30) Priority Data:
63/040,664 18 June 2020 (18.06.2020) US
63/111,844 10 November 2020 (10.11.2020) US

(71) Applicants: SMITH & NEPHEW, INC. [US/US]; 1450 Brooks Road, Memphis, Tennessee 38116 (US). SMITH & NEPHEW ORTHOPAEDICS AG [CH/CH]; Theiler-

strasse 1A, 6300 Zug (CH). SMITH & NEPHEW ASIA PACIFIC PTE. LIMITED [SG/SG]; 29 Media Circle, #06-05, Alice@Mediapolis, Singapore 138565 (SG).

(72) Inventors: QUIST, Brian William; 1450 Brooks Road, Memphis, Tennessee 38116 (US). NETRAVALI, Nathan Anil; 1450 Brooks Road, Memphis, Tennessee 38116 (US). TORRIE, Paul Alexander; 1450 Brooks Road, Memphis, Tennessee 38116 (US).

(74) Agent: GALLO, Nicholas J. et al.; Troutman Pepper Hamilton Sanders LLP, 501 Grant Street, Suite 300, Pittsburgh, Pennsylvania 15219-4429 (US).

(81) Designated States (unless otherwise indicated, for every kind of national protection available): AE, AG, AL, AM, AO, AT, AU, AZ, BA, BB, BG, BH, BN, BR, BW, BY, BZ, CA, CH, CL, CN, CO, CR, CU, CZ, DE, DJ, DK, DM, DO, DZ, EC, EE, EG, ES, FI, GB, GD, GE, GH, GM, GT, HN,

(54) Title: METHODS FOR AUTOREGISTRATION OF ARTHROSCOPIC VIDEO IMAGES TO PREOPERATIVE MODELS AND DEVICES THEREOF

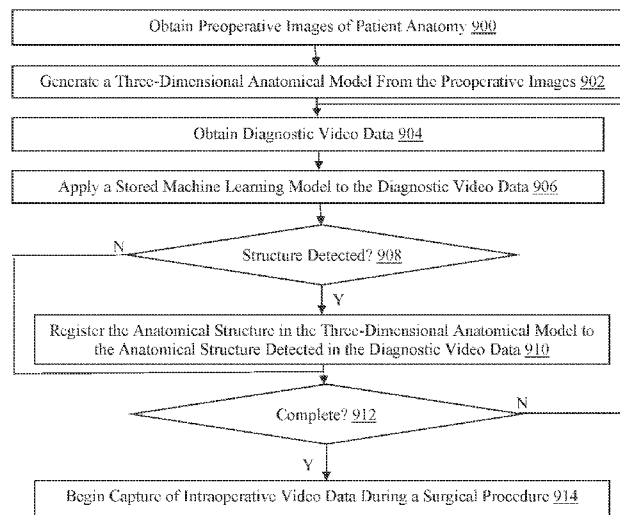

FIG. 9

(57) Abstract: Surgical methods and devices that facilitate registration of arthroscopic video to preoperative models are disclosed. With this technology, a machine learning model is applied to diagnostic video data captured via an arthroscope to identify an anatomical structure. An anatomical structure in a three-dimensional (3D) anatomical model is registered to the anatomical structure represented in the diagnostic video data. The 3D anatomical model is generated from preoperative image data. The anatomical structure is then tracked intraoperatively based on the registration and without requiring fixation of fiducial markers to the patient anatomy. A simulated projected view of the registered anatomical structure is generated from the 3D anatomical model based on a determined orientation of the arthroscope during capture of intraoperative video data. The simulated projected view is scaled and oriented based on one or more landmark features of the anatomical structure extracted from the intraoperative video data.



HR, HU, ID, IL, IN, IR, IS, IT, JO, JP, KE, KG, KH, KN, KP, KR, KW, KZ, LA, LC, LK, LR, LS, LU, LY, MA, MD, ME, MG, MK, MN, MW, MX, MY, MZ, NA, NG, NI, NO, NZ, OM, PA, PE, PG, PH, PL, PT, QA, RO, RS, RU, RW, SA, SC, SD, SE, SG, SK, SL, ST, SV, SY, TH, TJ, TM, TN, TR, TT, TZ, UA, UG, US, UZ, VC, VN, WS, ZA, ZM, ZW.

(84) Designated States (*unless otherwise indicated, for every kind of regional protection available*): ARIPO (BW, GH, GM, KE, LR, LS, MW, MZ, NA, RW, SD, SL, ST, SZ, TZ, UG, ZM, ZW), Eurasian (AM, AZ, BY, KG, KZ, RU, TJ, TM), European (AL, AT, BE, BG, CH, CY, CZ, DE, DK, EE, ES, FI, FR, GB, GR, HR, HU, IE, IS, IT, LT, LU, LV, MC, MK, MT, NL, NO, PL, PT, RO, RS, SE, SI, SK, SM, TR), OAPI (BF, BJ, CF, CG, CI, CM, GA, GN, GQ, GW, KM, ML, MR, NE, SN, TD, TG).

Published:

— *with international search report (Art. 21(3))*

METHODS FOR AUTOREGISTRATION OF ARTHROSCOPIC VIDEO IMAGES TO PREOPERATIVE MODELS AND DEVICES THEREOF

[0001] This application claims the benefit of U.S. Provisional Application Serial No. 63/040,664, filed on June 18, 2020, and U.S. Provisional Application Serial No. 63/111,844, filed on November 10, 2020, the contents of which are incorporated herein by reference in their entirety.

TECHNICAL FIELD

[0002] The present disclosure relates generally to methods, systems, and apparatuses related to a computer-assisted surgical system that includes various hardware and software components that work together to enhance surgical workflows. The disclosed techniques may be applied to, for example, shoulder, hip, and knee arthroplasties, as well as other surgical interventions such as arthroscopic procedures, spinal procedures, maxillofacial procedures, rotator cuff procedures, ligament repair and replacement procedures.

BACKGROUND

[0003] During computer navigated surgical procedures, various methods and devices are used to track the positions of a patient's anatomy and surgical devices within the operating environment, and surgical tracking is an essential component of navigational surgery systems. In particular, knowing where the surgical tool(s) and/or anatomical structure surface boundaries are in three-dimensional space is a core requirement of the current set of robotic-enabled surgical procedures in which precise bone modification is performed with the aid of computer assisted surgical systems (CASSs).

[0004] However, optical (e.g., infrared), electromagnetic, and mechanical tracking systems all have certain drawbacks. Optical tracking systems require that a line-of-sight be maintained between the tracking device and the instrument to be tracked, which is not always feasible in an operating environment and may preclude tracking of surgical instruments inside the body. Optical tracking systems also are only accurate within a defined volume with respect to camera position, which can be difficult to maintain throughout a surgical procedure.

[0005] Electromagnetic tracking systems similarly only provide accurate measurements within a defined volume with respect to the position of the field generator. Further, metal in the electromagnetic field, which is commonly used during orthopedic and sports medicine

procedures in particular, can generate interference and degrade the accuracy of the measurement.

[0006] As with optical and electromagnetic tracking systems, mechanical tracking systems also require components (e.g., tracking fiducials) to be attached physically to the patient anatomy, which can require pins, clamps, or other attachment mechanisms that damage the anatomy. Damage to patient anatomy results in a higher risk of complications from a surgical procedure. Accordingly, current surgical tracking systems used in navigated surgical procedures each have significant drawbacks and constraints.

SUMMARY

[0007] Surgical computing devices, systems, non-transitory computer readable media, and methods that facilitate automatic registration of arthroscopic video images to preoperative models are disclosed. According to some embodiments, a machine learning model is applied to diagnostic video data captured via an arthroscope to identify an anatomical structure represented in the diagnostic video data. One of a plurality of anatomical structures in a three-dimensional (3D) anatomical model is registered to the anatomical structure represented in the diagnostic video data. The 3D anatomical model is generated from preoperative image data. The anatomical structure is then tracked intraoperatively based on the registration. A simulated projected view of the registered one of the plurality of anatomical structures is generated from the 3D anatomical model based on a determined orientation of the arthroscope during capture by the arthroscope of intraoperative video data. The simulated projected view is scaled and oriented based on one or more landmark features of the anatomical structure extracted from the intraoperative video data. The scaled and oriented simulated projected view is then output, such as to a display device (e.g., a mixed reality headset).

[0008] According to some embodiments, an overlay is generated that includes the scaled and oriented simulated projected view. The generated overlay is then merged with the intraoperative video data based on the registration to generate merged video data, which is output to the display device.

[0009] According to some embodiments, a stage of a surgical procedure is determined based on an obtained surgical plan for the surgical procedure and identification of the anatomical structure in the intraoperative video data. The generated overlay further includes guidance extracted from the obtained surgical plan. In one or more of these embodiments, the guidance includes textual directions associated with a current task in the surgical

procedure or a visual indication of another one of the plurality of anatomical structures corresponding to a subsequent task in the surgical procedure.

[0010] According to some embodiments, an annotated version of the 3D anatomical model or the preoperative image data is obtained that identifies an anatomical point corresponding to a portion of patient anatomy or at least one of the one or more landmark features. In one or more of these embodiments, the generated overlay further includes an indication of the anatomical point.

[0011] According to some embodiments, the machine learning model is trained based on additional video data including a plurality of image frames each including at least one annotated representation of one or more of the plurality of anatomical structures.

[0012] According to some embodiments, the display device includes a mixed reality headset. In one or more of these embodiments, one or more of a position or an orientation of the mixed reality headset is tracked. The overlay is then generated using a field of view of the arthroscope to determine a local reference frame and based on a known spatial and scale relationship between the arthroscope field of view and another reference frame of the mixed reality headset determined based on the tracking.

[0013] According to some embodiments, at least a portion of the simulated projected view includes another one of the plurality of anatomical structures that is occluded in another field of view of the mixed reality headset.

[0014] According to some embodiments, an eye position of a user is determined and the scaled and oriented simulated projected view is output to a projector for projection onto patient skin based on the determined eye position.

[0015] According to some embodiments, the generated overlay includes a depiction of a tool or tool tip oriented according to the surgical plan, according to the determined stage of the surgical procedure, or to facilitate optimal access to a particular portion of patient anatomy.

[0016] According to some embodiments, the anatomical structure represented in the intraoperative video data includes soft tissue. In one or more of these embodiments, a size and position of a first portion of the soft tissue is determined from the intraoperative video data. Another machine learning model is then applied to the 3D anatomical model and the determined size and position to generate a representation of a second portion of the soft tissue in a morphed state. Additionally, the simulated projected view includes the representation of the second portion of the soft tissue in the morphed state.

[0017] According to some embodiments, an additional one of the plurality of anatomical structures from the 3D anatomical model is registered to the additional one of the plurality of anatomical structures represented in the intraoperative video data based on the registration of the one of the plurality of anatomical structures.

[0018] According to some embodiments, a weighting value is generated for each of a plurality of portions of the 3D anatomical model. In one or more of these embodiments, the simulated projected view is generated to include a subset of the plurality of portions based on the weighting values.

BRIEF DESCRIPTION OF THE DRAWINGS

[0019] The accompanying drawings, which are incorporated in and form a part of the specification, illustrate the embodiments of the invention and together with the written description serve to explain the principles, characteristics, and features of the invention. In the drawings:

[0020] FIG. 1 depicts an operating theatre including an illustrative computer-assisted surgical system (CASS) in accordance with an embodiment.

[0021] FIG. 2 depicts an example of an electromagnetic sensor device according to some embodiments.

[0022] FIG. 3A depicts an alternative example of an electromagnetic sensor device, with three perpendicular coils, according to some embodiments.

[0023] FIG. 3B depicts an alternative example of an electromagnetic sensor device, with two nonparallel, affixed coils, according to some embodiments.

[0024] FIG. 3C depicts an alternative example of an electromagnetic sensor device, with two nonparallel, separate coils, according to some embodiments.

[0025] FIG. 4 depicts an example of electromagnetic sensor devices and a patient bone according to some embodiments.

[0026] FIG. 5A depicts illustrative control instructions that a surgical computer provides to other components of a CASS in accordance with an embodiment.

[0027] FIG. 5B depicts illustrative control instructions that components of a CASS provide to a surgical computer in accordance with an embodiment.

[0028] FIG. 5C depicts an illustrative implementation in which a surgical computer is connected to a surgical data server via a network in accordance with an embodiment.

[0029] FIG. 6 depicts an operative patient care system and illustrative data sources in accordance with an embodiment.

[0030] FIG. 7A depicts an illustrative flow diagram for determining a pre-operative surgical plan in accordance with an embodiment.

[0031] FIG. 7B depicts an illustrative flow diagram for determining an episode of care including pre-operative, intraoperative, and post-operative actions in accordance with an embodiment.

[0032] FIG. 7C depicts illustrative graphical user interfaces including images depicting an implant placement in accordance with an embodiment.

[0033] FIG. 8 depicts a flowchart of an exemplary method for training a machine learning model to facilitate automatic registration of arthroscopic video images to preoperative models.

[0034] FIG. 9 depicts a flowchart of an exemplary method for applying a machine learning model to register anatomical structures represented in diagnostic arthroscopic video data and preoperative three-dimensional anatomical models.

[0035] FIG. 10 depicts a flowchart of an exemplary method for tracking registered anatomical structures in intraoperative video data and providing simulated projected views generated from preoperative three-dimensional anatomical models.

[0036] FIG. 11 depicts a flowchart of an exemplary method for generating merged video data based on registration of anatomical structures and including overlays generated to include analytical information according to a state of a surgical procedure.

[0037] FIG. 12 depicts a block diagram of an illustrative surgical computing device in which aspects of the illustrative embodiments are implemented.

DETAILED DESCRIPTION

[0038] This disclosure is not limited to the particular systems, devices and methods described, as these may vary. The terminology used in the description is for the purpose of describing the particular versions or embodiments only and is not intended to limit the scope.

[0039] As used in this document, the singular forms “a,” “an,” and “the” include plural references unless the context clearly dictates otherwise. Unless defined otherwise, all technical and scientific terms used herein have the same meanings as commonly understood by one of ordinary skill in the art. Nothing in this disclosure is to be construed as an admission that the embodiments described in this disclosure are not entitled to antedate such disclosure by virtue of prior invention. As used in this document, the term “comprising” means “including, but not limited to.”

[0040] Definitions

[0041] For the purposes of this disclosure, the term “implant” is used to refer to a prosthetic device or structure manufactured to replace or enhance a biological structure. For example, in a total hip replacement procedure a prosthetic acetabular cup (implant) is used to replace or enhance a patients worn or damaged acetabulum. While the term “implant” is generally considered to denote a man-made structure (as contrasted with a transplant), for the purposes of this specification an implant can include a biological tissue or material transplanted to replace or enhance a biological structure.

[0042] For the purposes of this disclosure, the term “real-time” is used to refer to calculations or operations performed on-the-fly as events occur or input is received by the operable system. However, the use of the term “real-time” is not intended to preclude operations that cause some latency between input and response, so long as the latency is an unintended consequence induced by the performance characteristics of the machine.

[0043] Although much of this disclosure refers to surgeons or other medical professionals by specific job title or role, nothing in this disclosure is intended to be limited to a specific job title or function. Surgeons or medical professionals can include any doctor, nurse, medical professional, or technician. Any of these terms or job titles can be used interchangeably with the user of the systems disclosed herein unless otherwise explicitly demarcated. For example, a reference to a surgeon also could apply, in some embodiments to a technician or nurse.

[0044] The systems, methods, and devices disclosed herein are particularly well adapted for surgical procedures that utilize surgical navigation systems, such as the NAVIO® surgical navigation system. NAVIO is a registered trademark of BLUE BELT TECHNOLOGIES, INC. of Pittsburgh, PA, which is a subsidiary of SMITH & NEPHEW, INC. of Memphis, TN.

[0045] CASS Ecosystem Overview

[0046] FIG. 1 provides an illustration of an example computer-assisted surgical system (CASS) 100, according to some embodiments. As described in further detail in the sections that follow, the CASS uses computers, robotics, and imaging technology to aid surgeons in performing orthopedic surgery procedures such as total knee arthroplasty (TKA) or total hip arthroplasty (THA). For example, surgical navigation systems can aid surgeons in locating patient anatomical structures, guiding surgical instruments, and implanting medical devices with a high degree of accuracy. Surgical navigation systems such as the CASS 100 often

employ various forms of computing technology to perform a wide variety of standard and minimally invasive surgical procedures and techniques. Moreover, these systems allow surgeons to more accurately plan, track and navigate the placement of instruments and implants relative to the body of a patient, as well as conduct pre-operative and intra-operative body imaging.

[0047] An Effector Platform 105 positions surgical tools relative to a patient during surgery. The exact components of the Effector Platform 105 will vary, depending on the embodiment employed. For example, for a knee surgery, the Effector Platform 105 may include an End Effector 105B that holds surgical tools or instruments during their use. The End Effector 105B may be a handheld device or instrument used by the surgeon (e.g., a NAVIO® hand piece or a cutting guide or jig) or, alternatively, the End Effector 105B can include a device or instrument held or positioned by a Robotic Arm 105A. While one Robotic Arm 105A is illustrated in FIG. 1, in some embodiments there may be multiple devices. As examples, there may be one Robotic Arm 105A on each side of an operating table T or two devices on one side of the table T. The Robotic Arm 105A may be mounted directly to the table T, be located next to the table T on a floor platform (not shown), mounted on a floor-to-ceiling pole, or mounted on a wall or ceiling of an operating room. The floor platform may be fixed or moveable. In one particular embodiment, the robotic arm 105A is mounted on a floor-to-ceiling pole located between the patient's legs or feet. In some embodiments, the End Effector 105B may include a suture holder or a stapler to assist in closing wounds. Further, in the case of two robotic arms 105A, the surgical computer 150 can drive the robotic arms 105A to work together to suture the wound at closure. Alternatively, the surgical computer 150 can drive one or more robotic arms 105A to staple the wound at closure.

[0048] The Effector Platform 105 can include a Limb Positioner 105C for positioning the patient's limbs during surgery. One example of a Limb Positioner 105C is the SMITH AND NEPHEW SPIDER2 system. The Limb Positioner 105C may be operated manually by the surgeon or alternatively change limb positions based on instructions received from the Surgical Computer 150 (described below). While one Limb Positioner 105C is illustrated in FIG. 1, in some embodiments there may be multiple devices. As examples, there may be one Limb Positioner 105C on each side of the operating table T or two devices on one side of the table T. The Limb Positioner 105C may be mounted directly to the table T, be located next to the table T on a floor platform (not shown), mounted on a pole, or mounted on a wall or ceiling of an operating room. In some embodiments, the Limb Positioner 105C can be used

in non-conventional ways, such as a retractor or specific bone holder. The Limb Positioner 105C may include, as examples, an ankle boot, a soft tissue clamp, a bone clamp, or a soft-tissue retractor spoon, such as a hooked, curved, or angled blade. In some embodiments, the Limb Positioner 105C may include a suture holder to assist in closing wounds.

[0049] The Effector Platform 105 may include tools, such as a screwdriver, light or laser, to indicate an axis or plane, bubble level, pin driver, pin puller, plane checker, pointer, finger, or some combination thereof.

[0050] Resection Equipment 110 (not shown in FIG. 1) performs bone or tissue resection using, for example, mechanical, ultrasonic, or laser techniques. Examples of Resection Equipment 110 include drilling devices, burring devices, oscillatory sawing devices, vibratory impaction devices, reamers, ultrasonic bone cutting devices, radio frequency ablation devices, reciprocating devices (such as a rasp or broach), and laser ablation systems. In some embodiments, the Resection Equipment 110 is held and operated by the surgeon during surgery. In other embodiments, the Effector Platform 105 may be used to hold the Resection Equipment 110 during use.

[0051] The Effector Platform 105 also can include a cutting guide or jig 105D that is used to guide saws or drills used to resect tissue during surgery. Such cutting guides 105D can be formed integrally as part of the Effector Platform 105 or Robotic Arm 105A, or cutting guides can be separate structures that can be matingly and/or removably attached to the Effector Platform 105 or Robotic Arm 105A. The Effector Platform 105 or Robotic Arm 105A can be controlled by the CASS 100 to position a cutting guide or jig 105D adjacent to the patient's anatomy in accordance with a pre-operatively or intraoperatively developed surgical plan such that the cutting guide or jig will produce a precise bone cut in accordance with the surgical plan.

[0052] The Tracking System 115 uses one or more sensors to collect real-time position data that locates the patient's anatomy and surgical instruments. For example, for TKA procedures, the Tracking System may provide a location and orientation of the End Effector 105B during the procedure. In addition to positional data, data from the Tracking System 115 also can be used to infer velocity/acceleration of anatomy/instrumentation, which can be used for tool control. In some embodiments, the Tracking System 115 may use a tracker array attached to the End Effector 105B to determine the location and orientation of the End Effector 105B. The position of the End Effector 105B may be inferred based on the position and orientation of the Tracking System 115 and a known relationship in three-dimensional space between the Tracking System 115 and the End Effector 105B. Various types of

tracking systems may be used in various embodiments of the present invention including, without limitation, Infrared (IR) tracking systems, electromagnetic (EM) tracking systems, video or image based tracking systems, and ultrasound registration and tracking systems. Using the data provided by the tracking system 115, the surgical computer 150 can detect objects and prevent collision. For example, the surgical computer 150 can prevent the Robotic Arm 105A and/or the End Effector 105B from colliding with soft tissue.

[0053] Any suitable tracking system can be used for tracking surgical objects and patient anatomy in the surgical theatre. For example, a combination of IR and visible light cameras can be used in an array. Various illumination sources, such as an IR LED light source, can illuminate the scene allowing three-dimensional imaging to occur. In some embodiments, this can include stereoscopic, tri-scopic, quad-scopic, etc. imaging. In addition to the camera array, which in some embodiments is affixed to a cart, additional cameras can be placed throughout the surgical theatre. For example, handheld tools or headsets worn by operators/surgeons can include imaging capability that communicates images back to a central processor to correlate those images with images captured by the camera array. This can give a more robust image of the environment for modeling using multiple perspectives. Furthermore, some imaging devices may be of suitable resolution or have a suitable perspective on the scene to pick up information stored in quick response (QR) codes or barcodes. This can be helpful in identifying specific objects not manually registered with the system. In some embodiments, the camera may be mounted on the Robotic Arm 105A.

[0054] Although, as discussed herein, the majority of tracking and/or navigation techniques utilize image-based tracking systems (e.g., IR tracking systems, video or image based tracking systems, etc.). However, electromagnetic (EM) based tracking systems are becoming more common for a variety of reasons. For example, implantation of standard optical trackers requires tissue resection (e.g., down to the cortex) as well as subsequent drilling and driving of cortical pins. Additionally, because optical trackers require a direct line of sight with a tracking system, the placement of such trackers may need to be far from the surgical site to ensure they do not restrict the movement of a surgeon or medical professional.

[0055] Generally, EM based tracking devices include one or more wire coils and a reference field generator. The one or more wire coils may be energized (e.g., via a wired or wireless power supply). Once energized, the coil creates an electromagnetic field that can be detected and measured (e.g., by the reference field generator or an additional device) in a manner that allows for the location and orientation of the one or more wire coils to be

determined. As should be understood by someone of ordinary skill in the art, a single coil, such as is shown in FIG. 2, is limited to detecting five (5) total degrees-of-freedom (DOF). For example, sensor 200 may be able to track/determine movement in the X, Y, or Z direction, as well as rotation around the Y-axis 202 or Z-axis 201. However, because of the electromagnetic properties of a coil, it is not possible to properly track rotational movement around the X axis.

[0056] Accordingly, in most electromagnetic tracking applications, a three coil system, such as that shown in FIG. 3A is used to enable tracking in all six degrees of freedom that are possible for a rigid body moving in a three-dimensional space (i.e., forward/backward 310, up/down 320, left/right 330, roll 340, pitch 350, and yaw 360). However, the inclusion of two additional coils and the 90° offset angles at which they are positioned may require the tracking device to be much larger. Alternatively, as one of skill in the art would know, less than three full coils may be used to track all 6DOF. In some EM based tracking devices, two coils may be affixed to each other, such as is shown in FIG. 3B. Because the two coils 301B and 302B are rigidly affixed to each other, not perfectly parallel, and have locations that are known relative to each other, it is possible to determine the sixth degree of freedom 303B with this arrangement.

[0057] Although the use of two affixed coils (e.g., 301B and 302B) allows for EM based tracking in 6DOF, the sensor device is substantially larger in diameter than a single coil because of the additional coil. Thus, the practical application of using an EM based tracking system in a surgical environment may require tissue resection and drilling of a portion of the patient bone to allow for insertion of a EM tracker. Alternatively, in some embodiments, it may be possible to implant/insert a single coil, or 5DOF EM tracking device, into a patient bone using only a pin (e.g., without the need to drill or carve out substantial bone).

[0058] Thus, as described herein, a solution is needed for which the use of an EM tracking system can be restricted to devices small enough to be inserted/embedded using a small diameter needle or pin (i.e., without the need to create a new incision or large diameter opening in the bone). Accordingly, in some embodiments, a second 5DOF sensor, which is not attached to the first, and thus has a small diameter, may be used to track all 6DOF. Referring now to FIG. 3C, in some embodiments, two 5DOF EM sensors (e.g., 301C and 302C) may be inserted into the patient (e.g., in a patient bone) at different locations and with different angular orientations (e.g., angle 303C is non-zero).

[0059] Referring now to FIG. 4, an example embodiment is shown in which a first 5DOF EM sensor 401 and a second 5DOF EM sensor 402 are inserted into the patient bone 403

using a standard hollow needle 405 that is typical in most OR(s). In a further embodiment, the first sensor 401 and the second sensor 402 may have an angle offset of " α " 404. In some embodiments, it may be necessary for the offset angle " α " 404 to be greater than a predetermined value (e.g., a minimum angle of 0.50° , 0.75° , etc.). This minimum value may, in some embodiments, be determined by the CASS and provided to the surgeon or medical professional during the surgical plan. In some embodiments, a minimum value may be based on one or more factors, such as, for example, the orientation accuracy of the tracking system, a distance between the first and second EM sensors. The location of the field generator, a location of the field detector, a type of EM sensor, a quality of the EM sensor, patient anatomy, and the like.

[0060] Accordingly, as discussed herein, in some embodiments, a pin/needle (e.g., a cannulated mounting needle, etc.) may be used to insert one or more EM sensors. Generally, the pin/needle would be a disposable component, while the sensors themselves may be reusable. However, it should be understood that this is only one potential system, and that various other systems may be used in which the pin/needle and/or EM sensors are independently disposable or reusable. In a further embodiment, the EM sensors may be affixed to the mounting needle/pin (e.g., using a luer-lock fitting or the like), which can allow for quick assembly and disassembly. In additional embodiments, the EM sensors may utilize an alternative sleeve and/or anchor system that allows for minimally invasive placement of the sensors.

[0061] In another embodiment, the above systems may allow for a multi-sensor navigation system that can detect and correct for field distortions that plague electromagnetic tracking systems. It should be understood that field distortions may result from movement of any ferromagnetic materials within the reference field. Thus, as one of ordinary skill in the art would know, a typical OR has a large number of devices (e.g., an operating table, LCD displays, lighting equipment, imaging systems, surgical instruments, etc.) that may cause interference. Furthermore, field distortions are notoriously difficult to detect. The use of multiple EM sensors enables the system to detect field distortions accurately, and/or to warn a user that the current position measurements may not be accurate. Because the sensors are rigidly fixed to the bony anatomy (e.g., via the pin/needle), relative measurement of sensor positions (X, Y, Z) may be used to detect field distortions. By way of non-limiting example, in some embodiments, after the EM sensors are fixed to the bone, the relative distance between the two sensors is known and should remain constant. Thus, any change in this distance could indicate the presence of a field distortion.

[0062] In some embodiments, specific objects can be manually registered by a surgeon with the system preoperatively or intraoperatively. For example, by interacting with a user interface, a surgeon may identify the starting location for a tool or a bone structure. By tracking fiducial marks associated with that tool or bone structure, or by using other conventional image tracking modalities, a processor may track that tool or bone as it moves through the environment in a three-dimensional model.

[0063] In some embodiments, certain markers, such as fiducial marks that identify individuals, important tools, or bones in the theater may include passive or active identifiers that can be picked up by a camera or camera array associated with the tracking system. For example, an IR LED can flash a pattern that conveys a unique identifier to the source of that pattern, providing a dynamic identification mark. Similarly, one or two dimensional optical codes (barcode, QR code, etc.) can be affixed to objects in the theater to provide passive identification that can occur based on image analysis. If these codes are placed asymmetrically on an object, they also can be used to determine an orientation of an object by comparing the location of the identifier with the extents of an object in an image. For example, a QR code may be placed in a corner of a tool tray, allowing the orientation and identity of that tray to be tracked. Other tracking modalities are explained throughout. For example, in some embodiments, augmented reality headsets can be worn by surgeons and other staff to provide additional camera angles and tracking capabilities.

[0064] In addition to optical tracking, certain features of objects can be tracked by registering physical properties of the object and associating them with objects that can be tracked, such as fiducial marks fixed to a tool or bone. For example, a surgeon may perform a manual registration process whereby a tracked tool and a tracked bone can be manipulated relative to one another. By impinging the tip of the tool against the surface of the bone, a three-dimensional surface can be mapped for that bone that is associated with a position and orientation relative to the frame of reference of that fiducial mark. By optically tracking the position and orientation (pose) of the fiducial mark associated with that bone, a model of that surface can be tracked with an environment through extrapolation.

[0065] The registration process that registers the CASS 100 to the relevant anatomy of the patient also can involve the use of anatomical landmarks, such as landmarks on a bone or cartilage. For example, the CASS 100 can include a 3D model of the relevant bone or joint and the surgeon can intraoperatively collect data regarding the location of bony landmarks on the patient's actual bone using a probe that is connected to the CASS. Bony landmarks can include, for example, the medial malleolus and lateral malleolus, the ends of the proximal

femur and distal tibia, and the center of the hip joint. The CASS 100 can compare and register the location data of bony landmarks collected by the surgeon with the probe with the location data of the same landmarks in the 3D model. Alternatively, the CASS 100 can construct a 3D model of the bone or joint without pre-operative image data by using location data of bony landmarks and the bone surface that are collected by the surgeon using a CASS probe or other means. The registration process also can include determining various axes of a joint. For example, for a TKA the surgeon can use the CASS 100 to determine the anatomical and mechanical axes of the femur and tibia. The surgeon and the CASS 100 can identify the center of the hip joint by moving the patient's leg in a spiral direction (i.e., circumduction) so the CASS can determine where the center of the hip joint is located.

[0066] A Tissue Navigation System 120 (not shown in FIG. 1) provides the surgeon with intraoperative, real-time visualization for the patient's bone, cartilage, muscle, nervous, and/or vascular tissues surrounding the surgical area. Examples of systems that may be employed for tissue navigation include fluorescent imaging systems and ultrasound systems.

[0067] The Display 125 provides graphical user interfaces (GUIs) that display images collected by the Tissue Navigation System 120 as well other information relevant to the surgery. For example, in one embodiment, the Display 125 overlays image information collected from various modalities (e.g., CT, MRI, X-ray, fluorescent, ultrasound, etc.) collected pre-operatively or intra-operatively to give the surgeon various views of the patient's anatomy as well as real-time conditions. The Display 125 may include, for example, one or more computer monitors. As an alternative or supplement to the Display 125, one or more members of the surgical staff may wear an Augmented Reality (AR) Head Mounted Device (HMD). For example, in FIG. 1 the Surgeon 111 is wearing an AR HMD 155 that may, for example, overlay pre-operative image data on the patient or provide surgical planning suggestions. Various example uses of the AR HMD 155 in surgical procedures are detailed in the sections that follow.

[0068] Surgical Computer 150 provides control instructions to various components of the CASS 100, collects data from those components, and provides general processing for various data needed during surgery. In some embodiments, the Surgical Computer 150 is a general purpose computer. In other embodiments, the Surgical Computer 150 may be a parallel computing platform that uses multiple central processing units (CPUs) or graphics processing units (GPU) to perform processing. In some embodiments, the Surgical Computer 150 is connected to a remote server over one or more computer networks (e.g., the Internet). The

remote server can be used, for example, for storage of data or execution of computationally intensive processing tasks.

[0069] Various techniques generally known in the art can be used for connecting the Surgical Computer 150 to the other components of the CASS 100. Moreover, the computers can connect to the Surgical Computer 150 using a mix of technologies. For example, the End Effector 105B may connect to the Surgical Computer 150 over a wired (i.e., serial) connection. The Tracking System 115, Tissue Navigation System 120, and Display 125 can similarly be connected to the Surgical Computer 150 using wired connections. Alternatively, the Tracking System 115, Tissue Navigation System 120, and Display 125 may connect to the Surgical Computer 150 using wireless technologies such as, without limitation, Wi-Fi, Bluetooth, Near Field Communication (NFC), or ZigBee.

[0070] Powered Impaction and Acetabular Reamer Devices

[0071] Part of the flexibility of the CASS design described above with respect to FIG. 1 is that additional or alternative devices can be added to the CASS 100 as necessary to support particular surgical procedures. For example, in the context of hip surgeries, the CASS 100 may include a powered impaction device. Impaction devices are designed to repeatedly apply an impaction force that the surgeon can use to perform activities such as implant alignment. For example, within a total hip arthroplasty (THA), a surgeon will often insert a prosthetic acetabular cup into the implant host's acetabulum using an impaction device. Although impaction devices can be manual in nature (e.g., operated by the surgeon striking an impactor with a mallet), powered impaction devices are generally easier and quicker to use in the surgical setting. Powered impaction devices may be powered, for example, using a battery attached to the device. Various attachment pieces may be connected to the powered impaction device to allow the impaction force to be directed in various ways as needed during surgery. Also, in the context of hip surgeries, the CASS 100 may include a powered, robotically controlled end effector to ream the acetabulum to accommodate an acetabular cup implant.

[0072] In a robotically-assisted THA, the patient's anatomy can be registered to the CASS 100 using CT or other image data, the identification of anatomical landmarks, tracker arrays attached to the patient's bones, and one or more cameras. Tracker arrays can be mounted on the iliac crest using clamps and/or bone pins and such trackers can be mounted externally through the skin or internally (either posterolaterally or anterolaterally) through the incision made to perform the THA. For a THA, the CASS 100 can utilize one or more

femoral cortical screws inserted into the proximal femur as checkpoints to aid in the registration process. The CASS 100 also can utilize one or more checkpoint screws inserted into the pelvis as additional checkpoints to aid in the registration process. Femoral tracker arrays can be secured to or mounted in the femoral cortical screws. The CASS 100 can employ steps where the registration is verified using a probe that the surgeon precisely places on key areas of the proximal femur and pelvis identified for the surgeon on the display 125. Trackers can be located on the robotic arm 105A or end effector 105B to register the arm and/or end effector to the CASS 100. The verification step also can utilize proximal and distal femoral checkpoints. The CASS 100 can utilize color prompts or other prompts to inform the surgeon that the registration process for the relevant bones and the robotic arm 105A or end effector 105B has been verified to a certain degree of accuracy (e.g., within 1mm).

[0073] For a THA, the CASS 100 can include a broach tracking option using femoral arrays to allow the surgeon to intraoperatively capture the broach position and orientation and calculate hip length and offset values for the patient. Based on information provided about the patient's hip joint and the planned implant position and orientation after broach tracking is completed, the surgeon can make modifications or adjustments to the surgical plan.

[0074] For a robotically-assisted THA, the CASS 100 can include one or more powered reamers connected or attached to a robotic arm 105A or end effector 105B that prepares the pelvic bone to receive an acetabular implant according to a surgical plan. The robotic arm 105A and/or end effector 105B can inform the surgeon and/or control the power of the reamer to ensure that the acetabulum is being resected (reamed) in accordance with the surgical plan. For example, if the surgeon attempts to resect bone outside of the boundary of the bone to be resected in accordance with the surgical plan, the CASS 100 can power off the reamer or instruct the surgeon to power off the reamer. The CASS 100 can provide the surgeon with an option to turn off or disengage the robotic control of the reamer. The display 125 can depict the progress of the bone being resected (reamed) as compared to the surgical plan using different colors. The surgeon can view the display of the bone being resected (reamed) to guide the reamer to complete the reaming in accordance with the surgical plan. The CASS 100 can provide visual or audible prompts to the surgeon to warn the surgeon that resections are being made that are not in accordance with the surgical plan.

[0075] Following reaming, the CASS 100 can employ a manual or powered impactor that is attached or connected to the robotic arm 105A or end effector 105B to impact trial implants and final implants into the acetabulum. The robotic arm 105A and/or end effector 105B can

be used to guide the impactor to impact the trial and final implants into the acetabulum in accordance with the surgical plan. The CASS 100 can cause the position and orientation of the trial and final implants vis-à-vis the bone to be displayed to inform the surgeon as to how the trial and final implant's orientation and position compare to the surgical plan, and the display 125 can show the implant's position and orientation as the surgeon manipulates the leg and hip. The CASS 100 can provide the surgeon with the option of re-planning and re-doing the reaming and implant impaction by preparing a new surgical plan if the surgeon is not satisfied with the original implant position and orientation.

[0076] Preoperatively, the CASS 100 can develop a proposed surgical plan based on a three dimensional model of the hip joint and other information specific to the patient, such as the mechanical and anatomical axes of the leg bones, the epicondylar axis, the femoral neck axis, the dimensions (e.g., length) of the femur and hip, the midline axis of the hip joint, the ASIS axis of the hip joint, and the location of anatomical landmarks such as the lesser trochanter landmarks, the distal landmark, and the center of rotation of the hip joint. The CASS-developed surgical plan can provide a recommended optimal implant size and implant position and orientation based on the three dimensional model of the hip joint and other information specific to the patient. The CASS-developed surgical plan can include proposed details on offset values, inclination and anteversion values, center of rotation, cup size, medialization values, superior-inferior fit values, femoral stem sizing and length.

[0077] For a THA, the CASS-developed surgical plan can be viewed preoperatively and intraoperatively, and the surgeon can modify CASS-developed surgical plan preoperatively or intraoperatively. The CASS-developed surgical plan can display the planned resection to the hip joint and superimpose the planned implants onto the hip joint based on the planned resections. The CASS 100 can provide the surgeon with options for different surgical workflows that will be displayed to the surgeon based on a surgeon's preference. For example, the surgeon can choose from different workflows based on the number and types of anatomical landmarks that are checked and captured and/or the location and number of tracker arrays used in the registration process.

[0078] According to some embodiments, a powered impaction device used with the CASS 100 may operate with a variety of different settings. In some embodiments, the surgeon adjusts settings through a manual switch or other physical mechanism on the powered impaction device. In other embodiments, a digital interface may be used that allows setting entry, for example, via a touchscreen on the powered impaction device. Such a digital interface may allow the available settings to vary based, for example, on the type of

attachment piece connected to the power attachment device. In some embodiments, rather than adjusting the settings on the powered impaction device itself, the settings can be changed through communication with a robot or other computer system within the CASS 100. Such connections may be established using, for example, a Bluetooth or Wi-Fi networking module on the powered impaction device. In another embodiment, the impaction device and end pieces may contain features that allow the impaction device to be aware of what end piece (cup impactor, broach handle, etc.) is attached with no action required by the surgeon, and adjust the settings accordingly. This may be achieved, for example, through a QR code, barcode, RFID tag, or other method.

[0079] Examples of the settings that may be used include cup impaction settings (e.g., single direction, specified frequency range, specified force and/or energy range); broach impaction settings (e.g., dual direction/oscillating at a specified frequency range, specified force and/or energy range); femoral head impaction settings (e.g., single direction/single blow at a specified force or energy); and stem impaction settings (e.g., single direction at specified frequency with a specified force or energy). Additionally, in some embodiments, the powered impaction device includes settings related to acetabular liner impaction (e.g., single direction/single blow at a specified force or energy). There may be a plurality of settings for each type of liner such as poly, ceramic, oxinium, or other materials. Furthermore, the powered impaction device may offer settings for different bone quality based on preoperative testing/imaging/knowledge and/or intraoperative assessment by surgeon. In some embodiments, the powered impactor device may have a dual function. For example, the powered impactor device not only could provide reciprocating motion to provide an impact force, but also could provide reciprocating motion for a broach or rasp.

[0080] In some embodiments, the powered impaction device includes feedback sensors that gather data during instrument use and send data to a computing device, such as a controller within the device or the Surgical Computer 150. This computing device can then record the data for later analysis and use. Examples of the data that may be collected include, without limitation, sound waves, the predetermined resonance frequency of each instrument, reaction force or rebound energy from patient bone, location of the device with respect to imaging (e.g., fluoro, CT, ultrasound, MRI, etc.) registered bony anatomy, and/or external strain gauges on bones.

[0081] Once the data is collected, the computing device may execute one or more algorithms in real-time or near real-time to aid the surgeon in performing the surgical procedure. For example, in some embodiments, the computing device uses the collected data

to derive information such as the proper final broach size (femur); when the stem is fully seated (femur side); or when the cup is seated (depth and/or orientation) for a THA. Once the information is known, it may be displayed for the surgeon's review, or it may be used to activate haptics or other feedback mechanisms to guide the surgical procedure.

[0082] Additionally, the data derived from the aforementioned algorithms may be used to drive operation of the device. For example, during insertion of a prosthetic acetabular cup with a powered impaction device, the device may automatically extend an impaction head (e.g., an end effector) moving the implant into the proper location, or turn the power off to the device once the implant is fully seated. In one embodiment, the derived information may be used to automatically adjust settings for quality of bone where the powered impaction device should use less power to mitigate femoral/acetabular/pelvic fracture or damage to surrounding tissues.

[0083] Robotic Arm

[0084] In some embodiments, the CASS 100 includes a robotic arm 105A that serves as an interface to stabilize and hold a variety of instruments used during the surgical procedure. For example, in the context of a hip surgery, these instruments may include, without limitation, retractors, a sagittal or reciprocating saw, the reamer handle, the cup impactor, the broach handle, and the stem inserter. The robotic arm 105A may have multiple degrees of freedom (like a Spider device), and have the ability to be locked in place (e.g., by a press of a button, voice activation, a surgeon removing a hand from the robotic arm, or other method).

[0085] In some embodiments, movement of the robotic arm 105A may be effectuated by use of a control panel built into the robotic arm system. For example, a display screen may include one or more input sources, such as physical buttons or a user interface having one or more icons, that direct movement of the robotic arm 105A. The surgeon or other healthcare professional may engage with the one or more input sources to position the robotic arm 105A when performing a surgical procedure.

[0086] A tool or an end effector 105B attached or integrated into a robotic arm 105A may include, without limitation, a burring device, a scalpel, a cutting device, a retractor, a joint tensioning device, or the like. In embodiments in which an end effector 105B is used, the end effector may be positioned at the end of the robotic arm 105A such that any motor control operations are performed within the robotic arm system. In embodiments in which a tool is used, the tool may be secured at a distal end of the robotic arm 105A, but motor control operation may reside within the tool itself.

[0087] The robotic arm 105A may be motorized internally to both stabilize the robotic arm, thereby preventing it from falling and hitting the patient, surgical table, surgical staff, etc., and to allow the surgeon to move the robotic arm without having to fully support its weight. While the surgeon is moving the robotic arm 105A, the robotic arm may provide some resistance to prevent the robotic arm from moving too fast or having too many degrees of freedom active at once. The position and the lock status of the robotic arm 105A may be tracked, for example, by a controller or the Surgical Computer 150.

[0088] In some embodiments, the robotic arm 105A can be moved by hand (e.g., by the surgeon) or with internal motors into its ideal position and orientation for the task being performed. In some embodiments, the robotic arm 105A may be enabled to operate in a “free” mode that allows the surgeon to position the arm into a desired position without being restricted. While in the free mode, the position and orientation of the robotic arm 105A may still be tracked as described above. In one embodiment, certain degrees of freedom can be selectively released upon input from user (e.g., surgeon) during specified portions of the surgical plan tracked by the Surgical Computer 150. Designs in which a robotic arm 105A is internally powered through hydraulics or motors or provides resistance to external manual motion through similar means can be described as powered robotic arms, while arms that are manually manipulated without power feedback, but which may be manually or automatically locked in place, may be described as passive robotic arms.

[0089] A robotic arm 105A or end effector 105B can include a trigger or other means to control the power of a saw or drill. Engagement of the trigger or other means by the surgeon can cause the robotic arm 105A or end effector 105B to transition from a motorized alignment mode to a mode where the saw or drill is engaged and powered on. Additionally, the CASS 100 can include a foot pedal (not shown) that causes the system to perform certain functions when activated. For example, the surgeon can activate the foot pedal to instruct the CASS 100 to place the robotic arm 105A or end effector 105B in an automatic mode that brings the robotic arm or end effector into the proper position with respect to the patient’s anatomy in order to perform the necessary resections. The CASS 100 also can place the robotic arm 105A or end effector 105B in a collaborative mode that allows the surgeon to manually manipulate and position the robotic arm or end effector into a particular location. The collaborative mode can be configured to allow the surgeon to move the robotic arm 105A or end effector 105B medially or laterally, while restricting movement in other directions. As discussed, the robotic arm 105A or end effector 105B can include a cutting device (saw, drill, and burr) or a cutting guide or jig 105D that will guide a cutting device. In

other embodiments, movement of the robotic arm 105A or robotically controlled end effector 105B can be controlled entirely by the CASS 100 without any, or with only minimal, assistance or input from a surgeon or other medical professional. In still other embodiments, the movement of the robotic arm 105A or robotically controlled end effector 105B can be controlled remotely by a surgeon or other medical professional using a control mechanism separate from the robotic arm or robotically controlled end effector device, for example using a joystick or interactive monitor or display control device.

[0090] The examples below describe uses of the robotic device in the context of a hip surgery; however, it should be understood that the robotic arm may have other applications for surgical procedures involving knees, shoulders, etc. One example of use of a robotic arm in the context of forming an anterior cruciate ligament (ACL) graft tunnel is described in WIPO Publication No. WO 2020/047051, filed August 28, 2019, entitled “Robotic Assisted Ligament Graft Placement and Tensioning,” the entirety of which is incorporated herein by reference.

[0091] A robotic arm 105A may be used for holding the retractor. For example in one embodiment, the robotic arm 105A may be moved into the desired position by the surgeon. At that point, the robotic arm 105A may lock into place. In some embodiments, the robotic arm 105A is provided with data regarding the patient’s position, such that if the patient moves, the robotic arm can adjust the retractor position accordingly. In some embodiments, multiple robotic arms may be used, thereby allowing multiple retractors to be held or for more than one activity to be performed simultaneously (e.g., retractor holding & reaming).

[0092] The robotic arm 105A may also be used to help stabilize the surgeon’s hand while making a femoral neck cut. In this application, control of the robotic arm 105A may impose certain restrictions to prevent soft tissue damage from occurring. For example, in one embodiment, the Surgical Computer 150 tracks the position of the robotic arm 105A as it operates. If the tracked location approaches an area where tissue damage is predicted, a command may be sent to the robotic arm 105A causing it to stop. Alternatively, where the robotic arm 105A is automatically controlled by the Surgical Computer 150, the Surgical Computer may ensure that the robotic arm is not provided with any instructions that cause it to enter areas where soft tissue damage is likely to occur. The Surgical Computer 150 may impose certain restrictions on the surgeon to prevent the surgeon from reaming too far into the medial wall of the acetabulum or reaming at an incorrect angle or orientation.

[0093] In some embodiments, the robotic arm 105A may be used to hold a cup impactor at a desired angle or orientation during cup impaction. When the final position has been

achieved, the robotic arm 105A may prevent any further seating to prevent damage to the pelvis.

[0094] The surgeon may use the robotic arm 105A to position the broach handle at the desired position and allow the surgeon to impact the broach into the femoral canal at the desired orientation. In some embodiments, once the Surgical Computer 150 receives feedback that the broach is fully seated, the robotic arm 105A may restrict the handle to prevent further advancement of the broach.

[0095] The robotic arm 105A may also be used for resurfacing applications. For example, the robotic arm 105A may stabilize the surgeon while using traditional instrumentation and provide certain restrictions or limitations to allow for proper placement of implant components (e.g., guide wire placement, chamfer cutter, sleeve cutter, plan cutter, etc.). Where only a burr is employed, the robotic arm 105A may stabilize the surgeon's handpiece and may impose restrictions on the handpiece to prevent the surgeon from removing unintended bone in contravention of the surgical plan.

[0096] The robotic arm 105A may be a passive arm. As an example, the robotic arm 105A may be a CIRQ robot arm available from Brainlab AG. CIRQ is a registered trademark of Brainlab AG, Olof-Palme-Str. 9 81829, München, FED REP of GERMANY. In one particular embodiment, the robotic arm 105A is an intelligent holding arm as disclosed in U.S. Patent Application No. 15/525,585 to Krinninger et al., U.S. Patent Application No. 15/561,042 to Nowatschin et al., U.S. Patent Application No. 15/561,048 to Nowatschin et al., and U.S. Patent No. 10,342,636 to Nowatschin et al., the entire contents of each of which is herein incorporated by reference.

[0097] Surgical Procedure Data Generation and Collection

[0098] The various services that are provided by medical professionals to treat a clinical condition are collectively referred to as an "episode of care." For a particular surgical intervention the episode of care can include three phases: pre-operative, intra-operative, and post-operative. During each phase, data is collected or generated that can be used to analyze the episode of care in order to understand various features of the procedure and identify patterns that may be used, for example, in training models to make decisions with minimal human intervention. The data collected over the episode of care may be stored at the Surgical Computer 150 or the Surgical Data Server 180 as a complete dataset. Thus, for each episode of care, a dataset exists that comprises all of the data collectively pre-operatively about the

patient, all of the data collected or stored by the CASS 100 intra-operatively, and any post-operative data provided by the patient or by a healthcare professional monitoring the patient.

[0099] As explained in further detail, the data collected during the episode of care may be used to enhance performance of the surgical procedure or to provide a holistic understanding of the surgical procedure and the patient outcomes. For example, in some embodiments, the data collected over the episode of care may be used to generate a surgical plan. In one embodiment, a high-level, pre-operative plan is refined intra-operatively as data is collected during surgery. In this way, the surgical plan can be viewed as dynamically changing in real-time or near real-time as new data is collected by the components of the CASS 100. In other embodiments, pre-operative images or other input data may be used to develop a robust plan preoperatively that is simply executed during surgery. In this case, the data collected by the CASS 100 during surgery may be used to make recommendations that ensure that the surgeon stays within the pre-operative surgical plan. For example, if the surgeon is unsure how to achieve a certain prescribed cut or implant alignment, the Surgical Computer 150 can be queried for a recommendation. In still other embodiments, the pre-operative and intra-operative planning approaches can be combined such that a robust pre-operative plan can be dynamically modified, as necessary or desired, during the surgical procedure. In some embodiments, a biomechanics-based model of patient anatomy contributes simulation data to be considered by the CASS 100 in developing preoperative, intraoperative, and post-operative/rehabilitation procedures to optimize implant performance outcomes for the patient.

[0100] Aside from changing the surgical procedure itself, the data gathered during the episode of care may be used as an input to other procedures ancillary to the surgery. For example, in some embodiments, implants can be designed using episode of care data. Example data-driven techniques for designing, sizing, and fitting implants are described in U.S. Patent Application No. 13/814,531 filed August 15, 2011 and entitled “Systems and Methods for Optimizing Parameters for Orthopaedic Procedures”; U.S. Patent Application No. 14/232,958 filed July 20, 2012 and entitled “Systems and Methods for Optimizing Fit of an Implant to Anatomy”; and U.S. Patent Application No. 12/234,444 filed September 19, 2008 and entitled “Operatively Tuning Implants for Increased Performance,” the entire contents of each of which are hereby incorporated by reference into this patent application.

[0101] Furthermore, the data can be used for educational, training, or research purposes. For example, using the network-based approach described below in FIG. 5C, other doctors or students can remotely view surgeries in interfaces that allow them to selectively view data as it is collected from the various components of the CASS 100. After the surgical procedure,

similar interfaces may be used to “playback” a surgery for training or other educational purposes, or to identify the source of any issues or complications with the procedure.

[0102] Data acquired during the pre-operative phase generally includes all information collected or generated prior to the surgery. Thus, for example, information about the patient may be acquired from a patient intake form or electronic medical record (EMR). Examples of patient information that may be collected include, without limitation, patient demographics, diagnoses, medical histories, progress notes, vital signs, medical history information, allergies, and lab results. The pre-operative data may also include images related to the anatomical area of interest. These images may be captured, for example, using Magnetic Resonance Imaging (MRI), Computed Tomography (CT), X-ray, ultrasound, or any other modality known in the art. The pre-operative data may also comprise quality of life data captured from the patient. For example, in one embodiment, pre-surgery patients use a mobile application (“app”) to answer questionnaires regarding their current quality of life. In some embodiments, preoperative data used by the CASS 100 includes demographic, anthropometric, cultural, or other specific traits about a patient that can coincide with activity levels and specific patient activities to customize the surgical plan to the patient. For example, certain cultures or demographics may be more likely to use a toilet that requires squatting on a daily basis.

[0103] FIGS. 5A and 5B provide examples of data that may be acquired during the intra-operative phase of an episode of care. These examples are based on the various components of the CASS 100 described above with reference to FIG. 1; however, it should be understood that other types of data may be used based on the types of equipment used during surgery and their use.

[0104] FIG. 5A shows examples of some of the control instructions that the Surgical Computer 150 provides to other components of the CASS 100, according to some embodiments. Note that the example of FIG. 5A assumes that the components of the Effector Platform 105 are each controlled directly by the Surgical Computer 150. In embodiments where a component is manually controlled by the Surgeon 111, instructions may be provided on the Display 125 or AR HMD 155 instructing the Surgeon 111 how to move the component.

[0105] The various components included in the Effector Platform 105 are controlled by the Surgical Computer 150 providing position commands that instruct the component where to move within a coordinate system. In some embodiments, the Surgical Computer 150 provides the Effector Platform 105 with instructions defining how to react when a component

of the Effector Platform 105 deviates from a surgical plan. These commands are referenced in FIG. 5A as “haptic” commands. For example, the End Effector 105B may provide a force to resist movement outside of an area where resection is planned. Other commands that may be used by the Effector Platform 105 include vibration and audio cues.

[0106] In some embodiments, the end effectors 105B of the robotic arm 105A are operatively coupled with cutting guide 105D. In response to an anatomical model of the surgical scene, the robotic arm 105A can move the end effectors 105B and the cutting guide 105D into position to match the location of the femoral or tibial cut to be performed in accordance with the surgical plan. This can reduce the likelihood of error, allowing the vision system and a processor utilizing that vision system to implement the surgical plan to place a cutting guide 105D at the precise location and orientation relative to the tibia or femur to align a cutting slot of the cutting guide with the cut to be performed according to the surgical plan. Then, a surgeon can use any suitable tool, such as an oscillating or rotating saw or drill to perform the cut (or drill a hole) with perfect placement and orientation because the tool is mechanically limited by the features of the cutting guide 105D. In some embodiments, the cutting guide 105D may include one or more pin holes that are used by a surgeon to drill and screw or pin the cutting guide into place before performing a resection of the patient tissue using the cutting guide. This can free the robotic arm 105A or ensure that the cutting guide 105D is fully affixed without moving relative to the bone to be resected. For example, this procedure can be used to make the first distal cut of the femur during a total knee arthroplasty. In some embodiments, where the arthroplasty is a hip arthroplasty, cutting guide 105D can be fixed to the femoral head or the acetabulum for the respective hip arthroplasty resection. It should be understood that any arthroplasty that utilizes precise cuts can use the robotic arm 105A and/or cutting guide 105D in this manner.

[0107] The Resection Equipment 110 is provided with a variety of commands to perform bone or tissue operations. As with the Effector Platform 105, position information may be provided to the Resection Equipment 110 to specify where it should be located when performing resection. Other commands provided to the Resection Equipment 110 may be dependent on the type of resection equipment. For example, for a mechanical or ultrasonic resection tool, the commands may specify the speed and frequency of the tool. For Radiofrequency Ablation (RFA) and other laser ablation tools, the commands may specify intensity and pulse duration.

[0108] Some components of the CASS 100 do not need to be directly controlled by the Surgical Computer 150; rather, the Surgical Computer 150 only needs to activate the

component, which then executes software locally specifying the manner in which to collect data and provide it to the Surgical Computer 150. In the example of FIG. 5A, there are two components that are operated in this manner: the Tracking System 115 and the Tissue Navigation System 120.

[0109] The Surgical Computer 150 provides the Display 125 with any visualization that is needed by the Surgeon 111 during surgery. For monitors, the Surgical Computer 150 may provide instructions for displaying images, GUIs, etc. using techniques known in the art. The display 125 can include various portions of the workflow of a surgical plan. During the registration process, for example, the display 125 can show a preoperatively constructed 3D bone model and depict the locations of the probe as the surgeon uses the probe to collect locations of anatomical landmarks on the patient. The display 125 can include information about the surgical target area. For example, in connection with a TKA, the display 125 can depict the mechanical and anatomical axes of the femur and tibia. The display 125 can depict varus and valgus angles for the knee joint based on a surgical plan, and the CASS 100 can depict how such angles will be affected if contemplated revisions to the surgical plan are made. Accordingly, the display 125 is an interactive interface that can dynamically update and display how changes to the surgical plan would impact the procedure and the final position and orientation of implants installed on bone.

[0110] As the workflow progresses to preparation of bone cuts or resections, the display 125 can depict the planned or recommended bone cuts before any cuts are performed. The surgeon 111 can manipulate the image display to provide different anatomical perspectives of the target area and can have the option to alter or revise the planned bone cuts based on intraoperative evaluation of the patient. The display 125 can depict how the chosen implants would be installed on the bone if the planned bone cuts are performed. If the surgeon 111 chooses to change the previously planned bone cuts, the display 125 can depict how the revised bone cuts would change the position and orientation of the implant when installed on the bone.

[0111] The display 125 can provide the surgeon 111 with a variety of data and information about the patient, the planned surgical intervention, and the implants. Various patient-specific information can be displayed, including real-time data concerning the patient's health such as heart rate, blood pressure, etc. The display 125 also can include information about the anatomy of the surgical target region including the location of landmarks, the current state of the anatomy (e.g., whether any resections have been made, the depth and angles of planned and executed bone cuts), and future states of the anatomy as the

surgical plan progresses. The display 125 also can provide or depict additional information about the surgical target region. For a TKA, the display 125 can provide information about the gaps (e.g., gap balancing) between the femur and tibia and how such gaps will change if the planned surgical plan is carried out. For a TKA, the display 125 can provide additional relevant information about the knee joint such as data about the joint's tension (e.g., ligament laxity) and information concerning rotation and alignment of the joint. The display 125 can depict how the planned implants' locations and positions will affect the patient as the knee joint is flexed. The display 125 can depict how the use of different implants or the use of different sizes of the same implant will affect the surgical plan and preview how such implants will be positioned on the bone. The CASS 100 can provide such information for each of the planned bone resections in a TKA or THA. In a TKA, the CASS 100 can provide robotic control for one or more of the planned bone resections. For example, the CASS 100 can provide robotic control only for the initial distal femur cut, and the surgeon 111 can manually perform other resections (anterior, posterior and chamfer cuts) using conventional means, such as a 4-in-1 cutting guide or jig 105D.

[0112] The display 125 can employ different colors to inform the surgeon of the status of the surgical plan. For example, un-resected bone can be displayed in a first color, resected bone can be displayed in a second color, and planned resections can be displayed in a third color. Implants can be superimposed onto the bone in the display 125, and implant colors can change or correspond to different types or sizes of implants.

[0113] The information and options depicted on the display 125 can vary depending on the type of surgical procedure being performed. Further, the surgeon 111 can request or select a particular surgical workflow display that matches or is consistent with his or her surgical plan preferences. For example, for a surgeon 111 who typically performs the tibial cuts before the femoral cuts in a TKA, the display 125 and associated workflow can be adapted to take this preference into account. The surgeon 111 also can preselect that certain steps be included or deleted from the standard surgical workflow display. For example, if a surgeon 111 uses resection measurements to finalize an implant plan but does not analyze ligament gap balancing when finalizing the implant plan, the surgical workflow display can be organized into modules, and the surgeon can select which modules to display and the order in which the modules are provided based on the surgeon's preferences or the circumstances of a particular surgery. Modules directed to ligament and gap balancing, for example, can include pre- and post-resection ligament/gap balancing, and the surgeon 111 can select which modules to include in their default surgical plan workflow depending on whether they

perform such ligament and gap balancing before or after (or both) bone resections are performed.

[0114] For more specialized display equipment, such as AR HMDs, the Surgical Computer 150 may provide images, text, etc. using the data format supported by the equipment. For example, if the Display 125 is a holography device such as the Microsoft HoloLens™ or Magic Leap One™, the Surgical Computer 150 may use the HoloLens Application Program Interface (API) to send commands specifying the position and content of holograms displayed in the field of view of the Surgeon 111.

[0115] In some embodiments, one or more surgical planning models may be incorporated into the CASS 100 and used in the development of the surgical plans provided to the surgeon 111. The term “surgical planning model” refers to software that simulates the biomechanics performance of anatomy under various scenarios to determine the optimal way to perform cutting and other surgical activities. For example, for knee replacement surgeries, the surgical planning model can measure parameters for functional activities, such as deep knee bends, gait, etc., and select cut locations on the knee to optimize implant placement. One example of a surgical planning model is the LIFEMOD™ simulation software from SMITH AND NEPHEW, INC. In some embodiments, the Surgical Computer 150 includes computing architecture that allows full execution of the surgical planning model during surgery (e.g., a GPU-based parallel processing environment). In other embodiments, the Surgical Computer 150 may be connected over a network to a remote computer that allows such execution, such as a Surgical Data Server 180 (see FIG. 5C). As an alternative to full execution of the surgical planning model, in some embodiments, a set of transfer functions are derived that simplify the mathematical operations captured by the model into one or more predictor equations. Then, rather than execute the full simulation during surgery, the predictor equations are used. Further details on the use of transfer functions are described in WIPO Publication No. 2020/037308, filed August 19, 2019, entitled “Patient Specific Surgical Method and System,” the entirety of which is incorporated herein by reference.

[0116] FIG. 5B shows examples of some of the types of data that can be provided to the Surgical Computer 150 from the various components of the CASS 100. In some embodiments, the components may stream data to the Surgical Computer 150 in real-time or near real-time during surgery. In other embodiments, the components may queue data and send it to the Surgical Computer 150 at set intervals (e.g., every second). Data may be communicated using any format known in the art. Thus, in some embodiments, the components all transmit data to the Surgical Computer 150 in a common format. In other

embodiments, each component may use a different data format, and the Surgical Computer 150 is configured with one or more software applications that enable translation of the data.

[0117] In general, the Surgical Computer 150 may serve as the central point where CASS data is collected. The exact content of the data will vary depending on the source. For example, each component of the Effector Platform 105 provides a measured position to the Surgical Computer 150. Thus, by comparing the measured position to a position originally specified by the Surgical Computer 150 (see FIG. 5B), the Surgical Computer can identify deviations that take place during surgery.

[0118] The Resection Equipment 110 can send various types of data to the Surgical Computer 150 depending on the type of equipment used. Example data types that may be sent include the measured torque, audio signatures, and measured displacement values. Similarly, the Tracking Technology 115 can provide different types of data depending on the tracking methodology employed. Example tracking data types include position values for tracked items (e.g., anatomy, tools, etc.), ultrasound images, and surface or landmark collection points or axes. The Tissue Navigation System 120 provides the Surgical Computer 150 with anatomic locations, shapes, etc. as the system operates.

[0119] Although the Display 125 generally is used for outputting data for presentation to the user, it may also provide data to the Surgical Computer 150. For example, for embodiments where a monitor is used as part of the Display 125, the Surgeon 111 may interact with a GUI to provide inputs which are sent to the Surgical Computer 150 for further processing. For AR applications, the measured position and displacement of the HMD may be sent to the Surgical Computer 150 so that it can update the presented view as needed.

[0120] During the post-operative phase of the episode of care, various types of data can be collected to quantify the overall improvement or deterioration in the patient's condition as a result of the surgery. The data can take the form of, for example, self-reported information reported by patients via questionnaires. For example, in the context of a knee replacement surgery, functional status can be measured with an Oxford Knee Score questionnaire, and the post-operative quality of life can be measured with a EQ5D-5L questionnaire. Other examples in the context of a hip replacement surgery may include the Oxford Hip Score, Harris Hip Score, and WOMAC (Western Ontario and McMaster Universities Osteoarthritis index). Such questionnaires can be administered, for example, by a healthcare professional directly in a clinical setting or using a mobile app that allows the patient to respond to questions directly. In some embodiments, the patient may be outfitted with one or more wearable devices that collect data relevant to the surgery. For example, following a knee

surgery, the patient may be outfitted with a knee brace that includes sensors that monitor knee positioning, flexibility, etc. This information can be collected and transferred to the patient's mobile device for review by the surgeon to evaluate the outcome of the surgery and address any issues. In some embodiments, one or more cameras can capture and record the motion of a patient's body segments during specified activities postoperatively. This motion capture can be compared to a biomechanics model to better understand the functionality of the patient's joints and better predict progress in recovery and identify any possible revisions that may be needed.

[0121] The post-operative stage of the episode of care can continue over the entire life of a patient. For example, in some embodiments, the Surgical Computer 150 or other components comprising the CASS 100 can continue to receive and collect data relevant to a surgical procedure after the procedure has been performed. This data may include, for example, images, answers to questions, "normal" patient data (e.g., blood type, blood pressure, conditions, medications, etc.), biometric data (e.g., gait, etc.), and objective and subjective data about specific issues (e.g., knee or hip joint pain). This data may be explicitly provided to the Surgical Computer 150 or other CASS component by the patient or the patient's physician(s). Alternatively or additionally, the Surgical Computer 150 or other CASS component can monitor the patient's EMR and retrieve relevant information as it becomes available. This longitudinal view of the patient's recovery allows the Surgical Computer 150 or other CASS component to provide a more objective analysis of the patient's outcome to measure and track success or lack of success for a given procedure. For example, a condition experienced by a patient long after the surgical procedure can be linked back to the surgery through a regression analysis of various data items collected during the episode of care. This analysis can be further enhanced by performing the analysis on groups of patients that had similar procedures and/or have similar anatomies.

[0122] In some embodiments, data is collected at a central location to provide for easier analysis and use. Data can be manually collected from various CASS components in some instances. For example, a portable storage device (e.g., USB stick) can be attached to the Surgical Computer 150 in order to retrieve data collected during surgery. The data can then be transferred, for example, via a desktop computer to the centralized storage. Alternatively, in some embodiments, the Surgical Computer 150 is connected directly to the centralized storage via a Network 175 as shown in FIG. 5C.

[0123] FIG. 5C illustrates a "cloud-based" implementation in which the Surgical Computer 150 is connected to a Surgical Data Server 180 via a Network 175. This Network

175 may be, for example, a private intranet or the Internet. In addition to the data from the Surgical Computer 150, other sources can transfer relevant data to the Surgical Data Server 180. The example of FIG. 5C shows 3 additional data sources: the Patient 160, Healthcare Professional(s) 165, and an EMR Database 170. Thus, the Patient 160 can send pre-operative and post-operative data to the Surgical Data Server 180, for example, using a mobile app. The Healthcare Professional(s) 165 includes the surgeon and his or her staff as well as any other professionals working with Patient 160 (e.g., a personal physician, a rehabilitation specialist, etc.). It should also be noted that the EMR Database 170 may be used for both pre-operative and post-operative data. For example, assuming that the Patient 160 has given adequate permissions, the Surgical Data Server 180 may collect the EMR of the Patient pre-surgery. Then, the Surgical Data Server 180 may continue to monitor the EMR for any updates post-surgery.

[0124] At the Surgical Data Server 180, an Episode of Care Database 185 is used to store the various data collected over a patient's episode of care. The Episode of Care Database 185 may be implemented using any technique known in the art. For example, in some embodiments, a SQL-based database may be used where all of the various data items are structured in a manner that allows them to be readily incorporated in two SQL's collection of rows and columns. However, in other embodiments a No-SQL database may be employed to allow for unstructured data, while providing the ability to rapidly process and respond to queries. As is understood in the art, the term "No-SQL" is used to define a class of data stores that are non-relational in their design. Various types of No-SQL databases may generally be grouped according to their underlying data model. These groupings may include databases that use column-based data models (e.g., Cassandra), document-based data models (e.g., MongoDB), key-value based data models (e.g., Redis), and/or graph-based data models (e.g., Allego). Any type of No-SQL database may be used to implement the various embodiments described herein and, in some embodiments, the different types of databases may support the Episode of Care Database 185.

[0125] Data can be transferred between the various data sources and the Surgical Data Server 180 using any data format and transfer technique known in the art. It should be noted that the architecture shown in FIG. 5C allows transmission from the data source to the Surgical Data Server 180, as well as retrieval of data from the Surgical Data Server 180 by the data sources. For example, as explained in detail below, in some embodiments, the Surgical Computer 150 may use data from past surgeries, machine learning models, etc. to help guide the surgical procedure.

[0126] In some embodiments, the Surgical Computer 150 or the Surgical Data Server 180 may execute a de-identification process to ensure that data stored in the Episode of Care Database 185 meets Health Insurance Portability and Accountability Act (HIPAA) standards or other requirements mandated by law. HIPAA provides a list of certain identifiers that must be removed from data during de-identification. The aforementioned de-identification process can scan for these identifiers in data that is transferred to the Episode of Care Database 185 for storage. For example, in one embodiment, the Surgical Computer 150 executes the de-identification process just prior to initiating transfer of a particular data item or set of data items to the Surgical Data Server 180. In some embodiments, a unique identifier is assigned to data from a particular episode of care to allow for re-identification of the data if necessary.

[0127] Although FIGS. 5A – 5C discuss data collection in the context of a single episode of care, it should be understood that the general concept can be extended to data collection from multiple episodes of care. For example, surgical data may be collected over an entire episode of care each time a surgery is performed with the CASS 100 and stored at the Surgical Computer 150 or at the Surgical Data Server 180. As explained in further detail below, a robust database of episode of care data allows the generation of optimized values, measurements, distances, or other parameters and other recommendations related to the surgical procedure. In some embodiments, the various datasets are indexed in the database or other storage medium in a manner that allows for rapid retrieval of relevant information during the surgical procedure. For example, in one embodiment, a patient-centric set of indices may be used so that data pertaining to a particular patient or a set of patients similar to a particular patient can be readily extracted. This concept can be similarly applied to surgeons, implant characteristics, CASS component versions, etc.

[0128] Further details of the management of episode of care data is described in U.S. Patent Application No. 62/783,858 filed December 21, 2018 and entitled “Methods and Systems for Providing an Episode of Care,” the entirety of which is incorporated herein by reference.

[0129] Open versus Closed Digital Ecosystems

[0130] In some embodiments, the CASS 100 is designed to operate as a self-contained or “closed” digital ecosystem. Each component of the CASS 100 is specifically designed to be used in the closed ecosystem, and data is generally not accessible to devices outside of the digital ecosystem. For example, in some embodiments, each component includes software or

firmware that implements proprietary protocols for activities such as communication, storage, security, etc. The concept of a closed digital ecosystem may be desirable for a company that wants to control all components of the CASS 100 to ensure that certain compatibility, security, and reliability standards are met. For example, the CASS 100 can be designed such that a new component cannot be used with the CASS unless it is certified by the company.

[0131] In other embodiments, the CASS 100 is designed to operate as an “open” digital ecosystem. In these embodiments, components may be produced by a variety of different companies according to standards for activities, such as communication, storage, and security. Thus, by using these standards, any company can freely build an independent, compliant component of the CASS platform. Data may be transferred between components using publicly available application programming interfaces (APIs) and open, shareable data formats.

[0132] To illustrate one type of recommendation that may be performed with the CASS 100, a technique for optimizing surgical parameters is disclosed below. The term “optimization” in this context means selection of parameters that are optimal based on certain specified criteria. In an extreme case, optimization can refer to selecting optimal parameter(s) based on data from the entire episode of care, including any pre-operative data, the state of CASS data at a given point in time, and post-operative goals. Moreover, optimization may be performed using historical data, such as data generated during past surgeries involving, for example, the same surgeon, past patients with physical characteristics similar to the current patient, or the like.

[0133] The optimized parameters may depend on the portion of the patient’s anatomy to be operated on. For example, for knee surgeries, the surgical parameters may include positioning information for the femoral and tibial component including, without limitation, rotational alignment (e.g., varus/valgus rotation, external rotation, flexion rotation for the femoral component, posterior slope of the tibial component), resection depths (e.g., varus knee, valgus knee), and implant type, size and position. The positioning information may further include surgical parameters for the combined implant, such as overall limb alignment, combined tibiofemoral hyperextension, and combined tibiofemoral resection. Additional examples of parameters that could be optimized for a given TKA femoral implant by the CASS 100 include the following:

Parameter	Reference	Exemplary Recommendation (s)
Size	Posterior	The largest sized implant that does not overhang medial/lateral bone edges or overhang the anterior femur. A size that does not result in overstuffing the patella femoral joint
Implant Position – Medial Lateral	Medial/lateral cortical bone edges	Center the implant evenly between the medial/lateral cortical bone edges
Resection Depth – Varus Knee	Distal and posterior lateral	6 mm of bone
Resection Depth – Valgus Knee	Distal and posterior medial	7 mm of bone
Rotation - Varus/Valgus	Mechanical Axis	1° varus
Rotation - External	Transepicondylar Axis	1° external from the transepicondylar axis
Rotation – Flexion	Mechanical Axis	3° flexed

[0134] Additional examples of parameters that could be optimized for a given TKA tibial implant by the CASS 100 include the following:

Parameter	Reference	Exemplary Recommendation (s)
Size	Posterior	The largest sized implant that does not overhang the medial, lateral, anterior, and posterior tibial edges
Implant Position	Medial/lateral and	Center the implant evenly between the

	anterior/posterior cortical bone edges	medial/lateral and anterior/posterior cortical bone edges
Resection Depth – Varus Knee	Lateral/Medial	4 mm of bone
Resection Depth – Valgus Knee	Lateral/Medial	5 mm of bone
Rotation - Varus/Valgus	Mechanical Axis	1° valgus
Rotation - External	Tibial Anterior Posterior Axis	1° external from the tibial anterior paxis
Posterior Slope	Mechanical Axis	3° posterior slope

[0135] For hip surgeries, the surgical parameters may comprise femoral neck resection location and angle, cup inclination angle, cup anteversion angle, cup depth, femoral stem design, femoral stem size, fit of the femoral stem within the canal, femoral offset, leg length, and femoral version of the implant.

[0136] Shoulder parameters may include, without limitation, humeral resection depth/angle, humeral stem version, humeral offset, glenoid version and inclination, as well as reverse shoulder parameters such as humeral resection depth/angle, humeral stem version, Glenoid tilt/version, glenosphere orientation, glenosphere offset and offset direction.

[0137] Various conventional techniques exist for optimizing surgical parameters. However, these techniques are typically computationally intensive and, thus, parameters often need to be determined pre-operatively. As a result, the surgeon is limited in his or her ability to make modifications to optimized parameters based on issues that may arise during surgery. Moreover, conventional optimization techniques typically operate in a “black box” manner with little or no explanation regarding recommended parameter values. Thus, if the surgeon decides to deviate from a recommended parameter value, the surgeon typically does so without a full understanding of the effect of that deviation on the rest of the surgical workflow, or the impact of the deviation on the patient’s post-surgery quality of life.

[0138] Operative Patient Care System

[0139] The general concepts of optimization may be extended to the entire episode of care using an Operative Patient Care System 620 that uses the surgical data, and other data from the Patient 605 and Healthcare Professionals 630 to optimize outcomes and patient satisfaction as depicted in FIG. 6.

[0140] Conventionally, pre-operative diagnosis, pre-operative surgical planning, intra-operative execution of a prescribed plan, and post-operative management of total joint arthroplasty are based on individual experience, published literature, and training knowledge bases of surgeons (ultimately, tribal knowledge of individual surgeons and their ‘network’ of peers and journal publications) and their native ability to make accurate intra-operative tactile discernment of “balance” and accurate manual execution of planar resections using guides and visual cues. This existing knowledge base and execution is limited with respect to the outcomes optimization offered to patients needing care. For example, limits exist with respect to accurately diagnosing a patient to the proper, least-invasive prescribed care; aligning dynamic patient, healthcare economic, and surgeon preferences with patient-desired outcomes; executing a surgical plan resulting in proper bone alignment and balance, etc.; and receiving data from disconnected sources having different biases that are difficult to reconcile into a holistic patient framework. Accordingly, a data-driven tool that more accurately models anatomical response and guides the surgical plan can improve the existing approach.

[0141] The Operative Patient Care System 620 is designed to utilize patient specific data, surgeon data, healthcare facility data, and historical outcome data to develop an algorithm that suggests or recommends an optimal overall treatment plan for the patient’s entire episode of care (preoperative, operative, and postoperative) based on a desired clinical outcome. For example, in one embodiment, the Operative Patient Care System 620 tracks adherence to the suggested or recommended plan, and adapts the plan based on patient/care provider performance. Once the surgical treatment plan is complete, collected data is logged by the Operative Patient Care System 620 in a historical database. This database is accessible for future patients and the development of future treatment plans. In addition to utilizing statistical and mathematical models, simulation tools (e.g., LIFEMOD®) can be used to simulate outcomes, alignment, kinematics, etc. based on a preliminary or proposed surgical plan, and reconfigure the preliminary or proposed plan to achieve desired or optimal results according to a patient’s profile or a surgeon’s preferences. The Operative Patient Care System 620 ensures that each patient is receiving personalized surgical and rehabilitative

care, thereby improving the chance of successful clinical outcomes and lessening the economic burden on the facility associated with near-term revision.

[0142] In some embodiments, the Operative Patient Care System 620 employs a data collecting and management method to provide a detailed surgical case plan with distinct steps that are monitored and/or executed using a CASS 100. The performance of the user(s) is calculated at the completion of each step and can be used to suggest changes to the subsequent steps of the case plan. Case plan generation relies on a series of input data that is stored on a local or cloud-storage database. Input data can be related to both the current patient undergoing treatment and historical data from patients who have received similar treatment(s).

[0143] A Patient 605 provides inputs such as Current Patient Data 610 and Historical Patient Data 615 to the Operative Patient Care System 620. Various methods generally known in the art may be used to gather such inputs from the Patient 605. For example, in some embodiments, the Patient 605 fills out a paper or digital survey that is parsed by the Operative Patient Care System 620 to extract patient data. In other embodiments, the Operative Patient Care System 620 may extract patient data from existing information sources, such as electronic medical records (EMRs), health history files, and payer/provider historical files. In still other embodiments, the Operative Patient Care System 620 may provide an application program interface (API) that allows the external data source to push data to the Operative Patient Care System. For example, the Patient 605 may have a mobile phone, wearable device, or other mobile device that collects data (e.g., heart rate, pain or discomfort levels, exercise or activity levels, or patient-submitted responses to the patient's adherence with any number of pre-operative plan criteria or conditions) and provides that data to the Operative Patient Care System 620. Similarly, the Patient 605 may have a digital application on his or her mobile or wearable device that enables data to be collected and transmitted to the Operative Patient Care System 620.

[0144] Current Patient Data 610 can include, but is not limited to, activity level, preexisting conditions, comorbidities, prehab performance, health and fitness level, pre-operative expectation level (relating to hospital, surgery, and recovery), a Metropolitan Statistical Area (MSA) driven score, genetic background, prior injuries (sports, trauma, etc.), previous joint arthroplasty, previous trauma procedures, previous sports medicine procedures, treatment of the contralateral joint or limb, gait or biomechanical information (back and ankle issues), levels of pain or discomfort, care infrastructure information (payer coverage type,

home health care infrastructure level, etc.), and an indication of the expected ideal outcome of the procedure.

[0145] Historical Patient Data 615 can include, but is not limited to, activity level, preexisting conditions, comorbidities, prehab performance, health and fitness level, pre-operative expectation level (relating to hospital, surgery, and recovery), a MSA driven score, genetic background, prior injuries (sports, trauma, etc.), previous joint arthroplasty, previous trauma procedures, previous sports medicine procedures, treatment of the contralateral joint or limb, gait or biomechanical information (back and ankle issues), levels or pain or discomfort, care infrastructure information (payer coverage type, home health care infrastructure level, etc.), expected ideal outcome of the procedure, actual outcome of the procedure (patient reported outcomes [PROs], survivorship of implants, pain levels, activity levels, etc.), sizes of implants used, position/orientation/alignment of implants used, soft-tissue balance achieved, etc.

[0146] Healthcare Professional(s) 630 conducting the procedure or treatment may provide various types of data 625 to the Operative Patient Care System 620. This Healthcare Professional Data 625 may include, for example, a description of a known or preferred surgical technique (e.g., Cruciate Retaining (CR) vs Posterior Stabilized (PS), up- vs down-sizing, tourniquet vs tourniquet-less, femoral stem style, preferred approach for THA, etc.), the level of training of the Healthcare Professional(s) 630 (e.g., years in practice, fellowship trained, where they trained, whose techniques they emulate), previous success level including historical data (outcomes, patient satisfaction), and the expected ideal outcome with respect to range of motion, days of recovery, and survivorship of the device. The Healthcare Professional Data 625 can be captured, for example, with paper or digital surveys provided to the Healthcare Professional 630, via inputs to a mobile application by the Healthcare Professional, or by extracting relevant data from EMRs. In addition, the CASS 100 may provide data such as profile data (e.g., a Patient Specific Knee Instrument Profile) or historical logs describing use of the CASS during surgery.

[0147] Information pertaining to the facility where the procedure or treatment will be conducted may be included in the input data. This data can include, without limitation, the following: Ambulatory Surgery Center (ASC) vs hospital, facility trauma level, Comprehensive Care for Joint Replacement Program (CJR) or bundle candidacy, a MSA driven score, community vs metro, academic vs non-academic, postoperative network access (Skilled Nursing Facility [SNF] only, Home Health, etc.), availability of medical professionals, implant availability, and availability of surgical equipment.

[0148] These facility inputs can be captured by, for example and without limitation, Surveys (Paper/Digital), Surgery Scheduling Tools (e.g., apps, Websites, Electronic Medical Records [EMRs], etc.), Databases of Hospital Information (on the Internet), etc. Input data relating to the associated healthcare economy including, but not limited to, the socioeconomic profile of the patient, the expected level of reimbursement the patient will receive, and if the treatment is patient specific may also be captured.

[0149] These healthcare economic inputs can be captured by, for example and without limitation, Surveys (Paper/Digital), Direct Payer Information, Databases of Socioeconomic status (on the Internet with zip code), etc. Finally, data derived from simulation of the procedure is captured. Simulation inputs include implant size, position, and orientation. Simulation can be conducted with custom or commercially available anatomical modeling software programs (e.g., LIFEMOD®, AnyBody, or OpenSIM). It is noted that the data inputs described above may not be available for every patient, and the treatment plan will be generated using the data that is available.

[0150] Prior to surgery, the Patient Data 610, 615 and Healthcare Professional Data 625 may be captured and stored in a cloud-based or online database (e.g., the Surgical Data Server 180 shown in FIG. 5C). Information relevant to the procedure is supplied to a computing system via wireless data transfer or manually with the use of portable media storage. The computing system is configured to generate a case plan for use with a CASS 100. Case plan generation will be described hereinafter. It is noted that the system has access to historical data from previous patients undergoing treatment, including implant size, placement, and orientation as generated by a computer-assisted, patient-specific knee instrument (PSKI) selection system, or automatically by the CASS 100 itself. To achieve this, case log data is uploaded to the historical database by a surgical sales rep or case engineer using an online portal. In some embodiments, data transfer to the online database is wireless and automated.

[0151] Historical data sets from the online database are used as inputs to a machine learning model such as, for example, a recurrent neural network (RNN) or other form of artificial neural network. As is generally understood in the art, an artificial neural network functions similar to a biologic neural network and is comprised of a series of nodes and connections. The machine learning model is trained to predict one or more values based on the input data. For the sections that follow, it is assumed that the machine learning model is trained to generate predictor equations. These predictor equations may be optimized to

determine the optimal size, position, and orientation of the implants to achieve the best outcome or satisfaction level.

[0152] Once the procedure is complete, all patient data and available outcome data, including the implant size, position and orientation determined by the CASS 100, are collected and stored in the historical database. Any subsequent calculation of the target equation via the RNN will include the data from the previous patient in this manner, allowing for continuous improvement of the system.

[0153] In addition to, or as an alternative to determining implant positioning, in some embodiments, the predictor equation and associated optimization can be used to generate the resection planes for use with a PSKI system. When used with a PSKI system, the predictor equation computation and optimization are completed prior to surgery. Patient anatomy is estimated using medical image data (x-ray, CT, MRI). Global optimization of the predictor equation can provide an ideal size and position of the implant components. Boolean intersection of the implant components and patient anatomy is defined as the resection volume. PSKI can be produced to remove the optimized resection envelope. In this embodiment, the surgeon cannot alter the surgical plan intraoperatively.

[0154] The surgeon may choose to alter the surgical case plan at any time prior to or during the procedure. If the surgeon elects to deviate from the surgical case plan, the altered size, position, and/or orientation of the component(s) is locked, and the global optimization is refreshed based on the new size, position, and/or orientation of the component(s) (using the techniques previously described) to find the new ideal position of the other component(s) and the corresponding resections needed to be performed to achieve the newly optimized size, position and/or orientation of the component(s). For example, if the surgeon determines that the size, position and/or orientation of the femoral implant in a TKA needs to be updated or modified intraoperatively, the femoral implant position is locked relative to the anatomy, and the new optimal position of the tibia will be calculated (via global optimization) considering the surgeon's changes to the femoral implant size, position and/or orientation. Furthermore, if the surgical system used to implement the case plan is robotically assisted (e.g., as with NAVIO® or the MAKO Rio), bone removal and bone morphology during the surgery can be monitored in real time. If the resections made during the procedure deviate from the surgical plan, the subsequent placement of additional components may be optimized by the processor taking into account the actual resections that have already been made.

[0155] FIG. 7A illustrates how the Operative Patient Care System 620 may be adapted for performing case plan matching services. In this example, data is captured relating to the

current patient 610 and is compared to all or portions of a historical database of patient data and associated outcomes 615. For example, the surgeon may elect to compare the plan for the current patient against a subset of the historical database. Data in the historical database can be filtered to include, for example, only data sets with favorable outcomes, data sets corresponding to historical surgeries of patients with profiles that are the same or similar to the current patient profile, data sets corresponding to a particular surgeon, data sets corresponding to a particular element of the surgical plan (e.g., only surgeries where a particular ligament is retained), or any other criteria selected by the surgeon or medical professional. If, for example, the current patient data matches or is correlated with that of a previous patient who experienced a good outcome, the case plan from the previous patient can be accessed and adapted or adopted for use with the current patient. The predictor equation may be used in conjunction with an intra-operative algorithm that identifies or determines the actions associated with the case plan. Based on the relevant and/or preselected information from the historical database, the intra-operative algorithm determines a series of recommended actions for the surgeon to perform. Each execution of the algorithm produces the next action in the case plan. If the surgeon performs the action, the results are evaluated. The results of the surgeon's performing the action are used to refine and update inputs to the intra-operative algorithm for generating the next step in the case plan. Once the case plan has been fully executed all data associated with the case plan, including any deviations performed from the recommended actions by the surgeon, are stored in the database of historical data. In some embodiments, the system utilizes preoperative, intraoperative, or postoperative modules in a piecewise fashion, as opposed to the entire continuum of care. In other words, caregivers can prescribe any permutation or combination of treatment modules including the use of a single module. These concepts are illustrated in FIG. 7B and can be applied to any type of surgery utilizing the CASS 100.

[0156] Surgery Process Display

[0157] As noted above with respect to FIGS. 1 and 5A-5C, the various components of the CASS 100 generate detailed data records during surgery. The CASS 100 can track and record various actions and activities of the surgeon during each step of the surgery and compare actual activity to the pre-operative or intraoperative surgical plan. In some embodiments, a software tool may be employed to process this data into a format where the surgery can be effectively "played-back." For example, in one embodiment, one or more GUIs may be used that depict all of the information presented on the Display 125 during

surgery. This can be supplemented with graphs and images that depict the data collected by different tools. For example, a GUI that provides a visual depiction of the knee during tissue resection may provide the measured torque and displacement of the resection equipment adjacent to the visual depiction to better provide an understanding of any deviations that occurred from the planned resection area. The ability to review a playback of the surgical plan or toggle between different phases of the actual surgery vs. the surgical plan could provide benefits to the surgeon and/or surgical staff, allowing such persons to identify any deficiencies or challenging phases of a surgery so that they can be modified in future surgeries. Similarly, in academic settings, the aforementioned GUIs can be used as a teaching tool for training future surgeons and/or surgical staff. Additionally, because the data set effectively records many elements of the surgeon's activity, it may also be used for other reasons (e.g., legal or compliance reasons) as evidence of correct or incorrect performance of a particular surgical procedure.

[0158] Over time, as more and more surgical data is collected, a rich library of data may be acquired that describes surgical procedures performed for various types of anatomy (knee, shoulder, hip, etc.) by different surgeons for different patients. Moreover, information such as implant type and dimension, patient demographics, etc. can further be used to enhance the overall dataset. Once the dataset has been established, it may be used to train a machine learning model (e.g., RNN) to make predictions of how surgery will proceed based on the current state of the CASS 100.

[0159] Training of the machine learning model can be performed as follows. The overall state of the CASS 100 can be sampled over a plurality of time periods for the duration of the surgery. The machine learning model can then be trained to translate a current state at a first time period to a future state at a different time period. By analyzing the entire state of the CASS 100 rather than the individual data items, any causal effects of interactions between different components of the CASS 100 can be captured. In some embodiments, a plurality of machine learning models may be used rather than a single model. In some embodiments, the machine learning model may be trained not only with the state of the CASS 100, but also with patient data (e.g., captured from an EMR) and an identification of members of the surgical staff. This allows the model to make predictions with even greater specificity. Moreover, it allows surgeons to selectively make predictions based only on their own surgical experiences if desired.

[0160] In some embodiments, predictions or recommendations made by the aforementioned machine learning models can be directly integrated into the surgical

workflow. For example, in some embodiments, the Surgical Computer 150 may execute the machine learning model in the background making predictions or recommendations for upcoming actions or surgical conditions. A plurality of states can thus be predicted or recommended for each period. For example, the Surgical Computer 150 may predict or recommend the state for the next 5 minutes in 30 second increments. Using this information, the surgeon can utilize a “process display” view of the surgery that allows visualization of the future state. For example, FIG. 7C depicts a series of images that may be displayed to the surgeon depicting the implant placement interface. The surgeon can cycle through these images, for example, by entering a particular time into the display 125 of the CASS 100 or instructing the system to advance or rewind the display in a specific time increment using a tactile, oral, or other instruction. In one embodiment, the process display can be presented in the upper portion of the surgeon’s field of view in the AR HMD. In some embodiments, the process display can be updated in real-time. For example, as the surgeon moves resection tools around the planned resection area, the process display can be updated so that the surgeon can see how his or her actions are affecting the other factors of the surgery.

[0161] In some embodiments, rather than simply using the current state of the CASS 100 as an input to the machine learning model, the inputs to the model may include a planned future state. For example, the surgeon may indicate that he or she is planning to make a particular bone resection of the knee joint. This indication may be entered manually into the Surgical Computer 150 or the surgeon may verbally provide the indication. The Surgical Computer 150 can then produce a film strip showing the predicted effect of the cut on the surgery. Such a film strip can depict over specific time increments how the surgery will be affected, including, for example, changes in the patient’s anatomy, changes to implant position and orientation, and changes regarding surgical intervention and instrumentation, if the contemplated course of action were to be performed. A surgeon or medical professional can invoke or request this type of film strip at any point in the surgery to preview how a contemplated course of action would affect the surgical plan if the contemplated action were to be carried out.

[0162] It should be further noted that, with a sufficiently trained machine learning model and robotic CASS, various elements of the surgery can be automated such that the surgeon only needs to be minimally involved, for example, by only providing approval for various steps of the surgery. For example, robotic control using arms or other means can be gradually integrated into the surgical workflow over time with the surgeon slowly becoming less and less involved with manual interaction versus robot operation. The machine learning

model in this case can learn what robotic commands are required to achieve certain states of the CASS-implemented plan. Eventually, the machine learning model may be used to produce a film strip or similar view or display that predicts and can preview the entire surgery from an initial state. For example, an initial state may be defined that includes the patient information, the surgical plan, implant characteristics, and surgeon preferences. Based on this information, the surgeon could preview an entire surgery to confirm that the CASS-recommended plan meets the surgeon's expectations and/or requirements. Moreover, because the output of the machine learning model is the state of the CASS 100 itself, commands can be derived to control the components of the CASS to achieve each predicted state. In the extreme case, the entire surgery could thus be automated based on just the initial state information.

[0163] Using the Point Probe to Acquire High-Resolution of Key Areas during Hip Surgeries

[0164] Use of the point probe is described in U.S. Patent Application No. 14/955,742 entitled "Systems and Methods for Planning and Performing Image Free Implant Revision Surgery," the entirety of which is incorporated herein by reference. Briefly, an optically tracked point probe may be used to map the actual surface of the target bone that needs a new implant. Mapping is performed after removal of the defective or worn-out implant, as well as after removal of any diseased or otherwise unwanted bone. A plurality of points is collected on the bone surfaces by brushing or scraping the entirety of the remaining bone with the tip of the point probe. This is referred to as tracing or "painting" the bone. The collected points are used to create a three-dimensional model or surface map of the bone surfaces in the computerized planning system. The created 3D model of the remaining bone is then used as the basis for planning the procedure and necessary implant sizes. An alternative technique that uses X-rays to determine a 3D model is described in U.S. Patent Application No. 16/387,151, filed April 17, 2019 and entitled "Three-Dimensional Selective Bone Matching" and U.S. Patent Application No. 16/789,930, filed February 13, 2020 and entitled "Three-Dimensional Selective Bone Matching," the entirety of each of which is incorporated herein by reference.

[0165] For hip applications, the point probe painting can be used to acquire high resolution data in key areas such as the acetabular rim and acetabular fossa. This can allow a surgeon to obtain a detailed view before beginning to ream. For example, in one embodiment, the point probe may be used to identify the floor (fossa) of the acetabulum. As

is well understood in the art, in hip surgeries, it is important to ensure that the floor of the acetabulum is not compromised during reaming so as to avoid destruction of the medial wall. If the medial wall were inadvertently destroyed, the surgery would require the additional step of bone grafting. With this in mind, the information from the point probe can be used to provide operating guidelines to the acetabular reamer during surgical procedures. For example, the acetabular reamer may be configured to provide haptic feedback to the surgeon when he or she reaches the floor or otherwise deviates from the surgical plan. Alternatively, the CASS 100 may automatically stop the reamer when the floor is reached or when the reamer is within a threshold distance.

[0166] As an additional safeguard, the thickness of the area between the acetabulum and the medial wall could be estimated. For example, once the acetabular rim and acetabular fossa has been painted and registered to the pre-operative 3D model, the thickness can readily be estimated by comparing the location of the surface of the acetabulum to the location of the medial wall. Using this knowledge, the CASS 100 may provide alerts or other responses in the event that any surgical activity is predicted to protrude through the acetabular wall while reaming.

[0167] The point probe may also be used to collect high resolution data of common reference points used in orienting the 3D model to the patient. For example, for pelvic plane landmarks like the ASIS and the pubic symphysis, the surgeon may use the point probe to paint the bone to represent a true pelvic plane. Given a more complete view of these landmarks, the registration software has more information to orient the 3D model.

[0168] The point probe may also be used to collect high-resolution data describing the proximal femoral reference point that could be used to increase the accuracy of implant placement. For example, the relationship between the tip of the Greater Trochanter (GT) and the center of the femoral head is commonly used as reference point to align the femoral component during hip arthroplasty. The alignment is highly dependent on proper location of the GT; thus, in some embodiments, the point probe is used to paint the GT to provide a high-resolution view of the area. Similarly, in some embodiments, it may be useful to have a high-resolution view of the Lesser Trochanter (LT). For example, during hip arthroplasty, the Dorr Classification helps to select a stem that will maximize the ability of achieving a press-fit during surgery to prevent micromotion of femoral components post-surgery and ensure optimal bony ingrowth. As is generated understood in the art, the Dorr Classification measures the ratio between the canal width at the LT and the canal width 10 cm below the LT. The accuracy of the classification is highly dependent on the correct location of the

relevant anatomy. Thus, it may be advantageous to paint the LT to provide a high-resolution view of the area.

[0169] In some embodiments, the point probe is used to paint the femoral neck to provide high-resolution data that allows the surgeon to better understand where to make the neck cut. The navigation system can then guide the surgeon as they perform the neck cut. For example, as understood in the art, the femoral neck angle is measured by placing one line down the center of the femoral shaft and a second line down the center of the femoral neck. Thus, a high-resolution view of the femoral neck (and possibly the femoral shaft as well) would provide a more accurate calculation of the femoral neck angle.

[0170] High-resolution femoral head neck data also could be used for a navigated resurfacing procedure where the software/hardware aids the surgeon in preparing the proximal femur and placing the femoral component. As is generally understood in the art, during hip resurfacing, the femoral head and neck are not removed; rather, the head is trimmed and capped with a smooth metal covering. In this case, it would be advantageous for the surgeon to paint the femoral head and cap so that an accurate assessment of their respective geometries can be understood and used to guide trimming and placement of the femoral component.

[0171] Registration of Pre-operative Data to Patient Anatomy using the Point Probe

As noted above, in some embodiments, a 3D model is developed during the pre-operative stage based on 2D or 3D images of the anatomical area of interest. In such embodiments, registration between the 3D model and the surgical site is performed prior to the surgical procedure. The registered 3D model may be used to track and measure the patient's anatomy and surgical tools intraoperatively.

[0172] During the surgical procedure, landmarks are acquired to facilitate registration of this pre-operative 3D model to the patient's anatomy. For knee procedures, these points could comprise the femoral head center, distal femoral axis point, medial and lateral epicondyles, medial and lateral malleolus, proximal tibial mechanical axis point, and tibial A/P direction. For hip procedures these points could comprise the anterior superior iliac spine (ASIS), the pubic symphysis, points along the acetabular rim and within the hemisphere, the greater trochanter (GT), and the lesser trochanter (LT).

[0173] In a revision surgery, the surgeon may paint certain areas that contain anatomical defects to allow for better visualization and navigation of implant insertion. These defects can be identified based on analysis of the pre-operative images. For example, in one

embodiment, each pre-operative image is compared to a library of images showing “healthy” anatomy (i.e., without defects). Any significant deviations between the patient’s images and the healthy images can be flagged as a potential defect. Then, during surgery, the surgeon can be warned of the possible defect via a visual alert on the display 125 of the CASS 100. The surgeon can then paint the area to provide further detail regarding the potential defect to the Surgical Computer 150.

[0174] In some embodiments, the surgeon may use a non-contact method for registration of bony anatomy intra-incision. For example, in one embodiment, laser scanning is employed for registration. A laser stripe is projected over the anatomical area of interest and the height variations of the area are detected as changes in the line. Other non-contact optical methods, such as white light interferometry or ultrasound, may alternatively be used for surface height measurement or to register the anatomy. For example, ultrasound technology may be beneficial where there is soft tissue between the registration point and the bone being registered (e.g., ASIS, pubic symphysis in hip surgeries), thereby providing for a more accurate definition of anatomic planes.

[0175] Referring now to FIG. 8, a flowchart of an exemplary method for training a machine learning model to facilitate automatic registration of arthroscopic video images to preoperative models in accordance with an embodiment of this technology is illustrated. The method described and illustrated with reference to FIG. 8 is carried out in some examples by a computing device internal or external to the CASS 100 and optionally communicably coupled to, but separate from, the surgical computer 150 (e.g., the computing device described and illustrated below with reference to FIG. 12). In step 800 in this example, training video data is obtained, which can be a dataset including a plurality of image frames associated with historical video feeds captured by an arthroscope during surgical procedures, for example. The image frames in the training video data can be annotated with labels noting the pixels or areas that belong to particular anatomical structures (e.g. an outlining of the femur, anterior cruciate ligament, and/or posterior cruciate ligament).

[0176] Alternatively, the image frames in the training video data can be annotated manually or automatically with image processing software assistance after the training video data is obtained to reflect the anatomical structure(s) depicted therein, and other methods for obtaining annotated training video data can also be used. Optionally, each set of image frames within the training video data is captured arthroscopically during a same surgical procedure (e.g., a total knee arthroplasty) and therefore includes one or more anatomical

structures from a same set of anatomical structures associated with particular patient anatomy (e.g., a knee joint) associated with the surgical procedure.

[0177] In step 802, at least one machine learning model is trained based on the annotated training video data. The machine learning model in some embodiments is trained to recognize anatomical structures in similar arthroscopic video data, such as arthroscopic video data obtained during a diagnostic review that is part of a same surgical procedure, as described and illustrated in more detail below. Accordingly, the machine learning model is trained based on the obtained training video data, which includes image frames annotated to identify represented anatomical structures, to identify those anatomical structures when the machine learning model is deployed and subsequently applied to diagnostic video data.

[0178] In some examples, the machine learning model, or a separate machine learning model, is trained based on training video data depicting soft tissue anatomical structures, along with preoperative images, and/or three-dimensional (3D) anatomical models generated therefrom, corresponding to the soft tissue anatomical structures. During some surgical procedures, the shape and position of soft tissue changes due to hydraulic expansion of a joint or the joint being in a different flexion or distraction state than when the preoperative imaging was captured, for example. With the preoperative imaging or models and corresponding training video data obtained during a diagnostic review or intraoperatively, the machine learning model is trained in these examples to predict the 3D position of soft tissue anatomical structures in a morphed state that matches the real-time arthroscopic view. Any number of algorithms can be used to train the machine learning model(s) including genetic, temporal difference, k-nearest neighbor, reinforcement learning, and/or expectation maximization algorithms, for example.

[0179] In step 804, a determination is made as to whether an accuracy of the trained machine learning model exceeds a threshold, which can be established automatically, empirically, and/or manually, for example. In other words, the determination in step 804 is whether to continue the training or whether the machine learning model is sufficiently accurate to be deployed. The accuracy of the machine learning model can be analyzed via a manual review and feedback loop, for example, although other methods of analyzing the accuracy can also be used. If the accuracy of the machine learning model does not exceed a threshold, then the No branch is taken back to step 800 and additional training video data is obtained, annotated, and/or used to further train the machine learning model. However, if the accuracy of the machine learning model exceeds the threshold, then the Yes branch is taken from step 804 to step 806.

[0180] In step 806, the machine learning model is stored for subsequent use in surgical procedures, although the machine learning model can be deployed in other manners in other examples. Optionally, the machine learning model can be deployed to and stored on the surgical computer 150 to facilitate intraoperative registration of anatomical structures, as explained in detail below.

[0181] Referring now to FIG. 9, a flowchart of an exemplary method for applying a machine learning model to register anatomical structures represented in diagnostic arthroscopic video data and preoperative 3D anatomical models in accordance with an embodiment of this technology is illustrated. In step 900 in this example, the surgical computer 150 obtains preoperative images of patient anatomy (e.g., a knee joint). The preoperative images can be CT or MRI images, for example, although other types of two dimensional (2D) images can also be used in other examples.

[0182] In step 902, the surgical computer 150 generates a 3D anatomical model from the preoperative images, as is known in the art. While the surgical computer 150 performs steps 900-902 in this particular example, the preoperative imaging and model generation can be performed by a different device in the CASS 100 or external to the CASS in other examples. In these examples, the 3D model can be obtained by the surgical computer 150 at the beginning of or during a surgical procedure associated with the patient, for example.

[0183] In step 904, the surgical computer 150 obtains diagnostic video data captured by an arthroscope during a diagnostic review phase of the surgical procedure for the patient. During arthroscopic procedures, one of the initial steps is to perform a diagnostic review of the associated joint(s). For example, in a knee arthroscopy, a systematic review may include sequentially observing with an arthroscope the lateral compartment including the lateral meniscus, posterolateral corner and cartilage, the central pillar including the ACL, PCL and fat body, the superior part of the knee including the retropatellar cartilage, femoral groove, and suprapatellar recessus, and the medial compartment including the medial meniscus, medial collateral ligament, and cartilage. Image frames within the diagnostic video data captured during the diagnostic review phase of a surgical procedure can be obtained in step 904 and used to automatically register the patient anatomy without requiring the fixation of fiducial markers to the patient.

[0184] In particular, in step 906, the surgical computer 150 applies a stored machine learning model to the diagnostic video data as the diagnostic video data is captured (e.g., in real-time and/or immediately subsequent to the capture of the diagnostic video data). The machine learning model may be applied to the diagnostic video data captured via the

arthroscope to identify or resolve anatomical structure(s) represented in the diagnostic video data in this particular example. In some embodiments, the machine learning model may have been generated by the surgical computer 150 or another computing device as described and illustrated above with reference to FIG. 8, and may have been stored by the surgical computer as explained with reference to step 806 of FIG. 8, for example. Other methods of generating and storing the machine learning model will be apparent to those of ordinary skill in the art.

[0185] The technology described and illustrated herein can leverage the systematic nature and repeatability of the diagnostic review to predict the anatomical structures depicted in particular image frames or portions of the diagnostic video data, and thereby more effectively identify and register anatomical structures within a joint. Due to the nature of standard diagnostic arthroscopy, the anatomical structures are visualized from a variety of perspectives, which aids in the prediction and identification process because capturing more surfaces and perspectives results in a more efficient and effective registration. While the machine learning model is applied to diagnostic video data in the examples described and illustrated herein, the machine learning model can be applied to intraoperative video data obtained subsequent to the diagnostic review phase of a surgical procedure and/or a combination of diagnostic and intraoperative video data in other examples.

[0186] In step 908, the surgical computer 150 determines whether an unregistered anatomical structure is detected as a result of the application of the machine learning model in step 906 to the current diagnostic video data obtained in step 904. In an initial iteration, no anatomical structures will have been previously registered. Accordingly, if the surgical computer 150 determines that at least one unregistered anatomical structure is detected, then the Yes branch is taken to step 910.

[0187] In step 910, the surgical computer 150 registers the anatomical structure in the 3D anatomical model generated in step 902 to the anatomical structure detected in the diagnostic video data. The registration facilitates subsequent intraoperative tracking of the anatomical structure as well as visualization of portions of the anatomical structure occluded during the surgical procedure (e.g., via an overlay merged with intraoperative video data), among other advantages described and illustrated in more detail below. However, if the surgical computer 150 determines in step 908 that an unregistered anatomical structure has not been detected in the current iteration, then the No branch is taken to step 912.

[0188] In step 912, the surgical computer 150 optionally determines whether the diagnostic review phase of the surgical procedure is complete. In some embodiments, this determination may be made based on a manual input from a surgeon. In some embodiments,

this determination may be made automatically based on a sensed parameter(s) associated with the operating environment. If the surgical computer 150 determines that the diagnostic review phase is not complete, then the No branch is taken back to step 904, and the surgical computer 150 continues to analyze diagnostic video data using the machine learning model in order to attempt to register anatomical structures.

[0189] In some examples, the surgical computer 150 attempts to register as many anatomical structures as possible in steps 904-912 during the diagnostic review portion of the surgical procedure. In other examples, as few as a single anatomical structure is registered with the location and position of one or more additional or remaining anatomical structures being determined in relation to the registered anatomical structure and/or one or more other reference frames.

[0190] For example, initial determination of anatomical landmark features could be selected using a probe outfitted with a tracking fiducial, which would enable a user to paint the surface contour onto the anatomy to determine the 3D surface and would anchor the 3D points relative to the detected anatomical surface. By using the machine learning model to detect anatomical structure(s), the local reference frame could be extrapolated from the relationship of the anatomical structures relative to one another. This approach may require “painting” the surface from multiple camera view angles if the visual field will be used to generate the “local” reference frame.

[0191] In other examples, the contour of just a single or a few known anatomical structures or landmarks could be determined for placement of the local reference frame. In such embodiments, a bone model or soft tissue model could be fit to only the known or detected anatomical structures (e.g., the surface of the glenoid) using key anatomical landmarks/features. In some cases, other bone or soft tissue model features may also be positioned relative to the bone or soft-tissue model’s anchor structure (e.g. the glenoid).

[0192] As depicted in FIG. 9, the surgical computer 150 effectively applies the machine learning model to the diagnostic video data in step 906 until an anatomical structure of the patient is detected or until the diagnostic review is completed. Optionally, in subsequent iterations of step 906, the machine learning model can be applied to any portion of the diagnostic video data obtained in a prior iteration of step 904 along with diagnostic video data obtained in a current iteration. If the surgical computer 150 determines in step 912 that the diagnostic review phase of the surgical procedure is complete, then the Yes branch is taken to step 914.

[0193] In step 914, the surgical computer 150 begins obtaining intraoperative video data captured by the arthroscope during the surgical procedure and subsequent to the diagnostic review phase. By registering the anatomical structures in the surgical environment with those represented in the 3D anatomical model, the surgical computer 150 can track the anatomical structures and provide simulated projected views based on the 3D anatomical model, as described and illustrated in more detail below with reference to FIGS. 10-11. Further advantages of such a system may also result and/or be apparent to those of ordinary skill in the art.

[0194] Referring specifically to FIG. 10, a flowchart of an exemplary method for tracking registered anatomical structures in intraoperative video data and providing simulated projected views generated from preoperative 3D anatomical models in accordance with an embodiment of this technology is illustrated. In step 1000 in this example, the surgical computer 150 tracks at least one registered anatomical structure during capture of intraoperative video data. In this particular example, the intraoperative video data is captured by an arthroscope during a surgical procedure after diagnostic video data is captured during a diagnostic review phase of the surgical procedure, although the intraoperative video data can be captured at other times in other examples. Optionally, the surgical computer 150 can use a biological compatible dye or resorbable bone anchor, for example, to serve as the ground-truth for the anatomical reference frame by creating a visible marker distinguishable from the background anatomical structures in order to assist with the tracking and further improve the accuracy of the tracking performed by the surgical computer 150.

[0195] In step 1002, the surgical computer 150 determines an orientation of the arthroscope and extracts landmark features of the anatomical structure tracked in step 1000. In some examples, the landmark features can be extracted from an image frame of the intraoperative video data captured in step 1000 based on an application of a machine learning model, such as the machine learning model generated as described in detail above with reference to FIG. 8, for example, although other image analysis techniques and algorithms can also be used. In other examples, the anatomical features can be identified manually based on a received input or selection on a display of the image frame output to a display device. The orientation of the arthroscope can be determined based on a tracking of the arthroscope by a tracking system within the operative environment (e.g., vid fiducial markers attached to the arthroscope), although the machine learning model can also be used to predict the arthroscope orientation and other methods of determining the orientation of the arthroscope can also be used.

[0196] In step 1004, the surgical computer 150 generates a simulated projected view of at least the registered anatomical structure from the 3D anatomical model generated as described earlier with reference to step 902 of FIG. 9. The simulated projected view of the registered anatomical structure is generated in one example from the 3D anatomical model based on the determined orientation of the arthroscope during capture of the intraoperative video data. In some examples, one or more of a plurality of registered anatomical structures depicted in an image frame of the intraoperative video data is best-fit to a respective bone or soft-tissue model.

[0197] Optionally, at least a portion of the simulated projected view includes one or more anatomical structures that are occluded in a field of view of the arthroscope and/or a mixed reality headset worn by a surgeon during the surgical procedure that may display the intraoperative video data captured by the arthroscope. The occluded anatomical structure(s) are appropriately located, scaled, and oriented within the simulated projected view based on a prior registration of the occluded anatomical structures directly or indirectly based on the registration of another anatomical structure associated with the joint, for example. The occluded anatomical structure(s) can then be displayed via merged video within the mixed reality headset, as described in more detail below.

[0198] In some embodiments, the surgical computer 150 can generate and apply different weightings to different areas of the 3D model based on the variability in the appearance of particular portions or anatomical structures in the 2D representation when viewed with the arthroscope and/or the likelihood of the particular portions or anatomical structures being seen during a standard arthroscopic procedure, for example. For example, the medial and lateral eminences of the tibial spine have a higher surface variability and could have a higher weight for model fitting as compared to the medial or lateral plateaus, which have limited variability. Accordingly, the simulated projected view can be generated to include any portion of the 3D anatomical model based on any number of parameters and requirements for a particular deployment of this technology and/or type of surgical procedure, for example.

[0199] According to some embodiments, at least one of the anatomical structures represented in the intraoperative video data includes soft tissue. In one or more of these embodiments, a size and position of a first portion of the soft tissue is determined from the intraoperative video data. The machine learning model may be applied to the 3D anatomical model and the determined size and position of the first portion of the soft tissue to generate a representation of a second portion of the soft tissue in a morphed state. Additionally, the simulated projected view may include the representation of the second portion of the soft

tissue in the morphed state. During surgery, the soft tissue's shape and position change. The arthroscopic view with this technology may advantageously allow for real-time determination of the shape and position of at least one side of these structures.

[0200] In step 1006, the surgical computer 150 scales and orients the simulated projected view. The simulated projected view is scaled and oriented based on one or more of the landmark features of the anatomical structure extracted from the intraoperative video data in step 1002, for example, although the simulated projected view can be scaled and/or oriented in other ways in other examples.

[0201] In step 1008, the surgical computer 150 outputs the scaled and oriented simulated projected view to a display device. According to some embodiments, an overlay is generated that includes the scaled and oriented simulated projected view. The generated overlay is then merged with the intraoperative video data provided by the arthroscope based on the registration to the visible anatomy to generate merged video data, which is output to a mixed reality headset display device worn by a surgeon.

[0202] In some examples, one or more of a position or an orientation of the mixed reality headset is tracked by a tracking system of the CASS 100 and via one or more fiducial markers (e.g., a QR code) attached to the mixed reality headset. In these examples, the overlay can be generated using a field of view of the arthroscope and a known spatial and scale relationship between the arthroscope field of view and another reference frame of the mixed reality headset that is determined based on the tracking. Accordingly, the external mixed reality headset could overlay the bone or soft tissue model, or a portion thereof, utilizing the arthroscope field of view as the mechanism to determine the local reference frame, which would advantageously enable the surgeon to see the bone or soft tissue model "through the skin" utilizing the arthroscope. Additionally, anatomical structures of interest that would not be directly visible by the arthroscope due to occlusion could be overlaid onto the arthroscopic view (e.g., within the mixed reality headset), which would allow a surgeon to view patient anatomy from an internal, arthroscopic perspective.

[0203] In yet other examples, the generated overlay can further include analytical or contextual information. For example, an annotated version of the 3D anatomical model or the preoperative image data can be obtained that identifies an anatomical point corresponding to a portion of patient anatomy or at least one landmark feature. In one or more of these embodiments, the generated overlay further includes an indication of the anatomical point. In some embodiments, a separate device external to the CASS 100 could be used to annotate the bone model, soft-tissue model, and/or MRI or CT preoperative image data to highlight a

particular structure and/or landmark feature, which would then map to the bone or soft-tissue model as a specific anatomical point that is then overlaid on the screen following the 3D anatomical model registration.

[0204] The analytical information included in the generated overlay can also include indications of probes or tools or associated trajectories. In other words, a probe or tool can be placed on a specific part of a bone or soft tissue, and the trajectory of the tool can be viewed through the tissue. For example, an indication of the location at which a guidewire or drill may exit can be represented, assistance with locating an internal tear of the meniscus can be provided, and/or a bony cyst can be represented to facilitate avoidance. Alternatively, the surgeon can place a tool on a specific point and view reconstructed MRI or CT slice views along the trajectory of the tool or perpendicular to the tool. In another example, a tool such as a guide can be placed in a specific location and orientation, and the surgical computer 150 can simulate a fluoroscopy image or post-operative image showing a tunnel location that would result from drilling the tunnel in that location. Accordingly, the additional analytical information can advantageously aid in decision-making with respect to placement of tunnels, anchors, sutures, or other implants.

[0205] The represented tool or tool tip can also be depicted based on a surgical plan, according to the determined stage of the surgical procedure (as described and illustrated in detail below with reference to FIG. 11), or to facilitate optimal access to a particular portion of patient anatomy. Projections of tools can be portrayed in the surgeon's field of view output to a head-mounted display, which guides the surgeon with how to access a joint using a specific tool. The projection can depict an optimal orientation or multiple orientations by which a tool tip can reach a certain area or structure within the joint. The tool positions can be optimized to access difficult to reach areas (e.g., the posterior horn of the meniscus), to avoid certain high risk structures (e.g., neurovascular structures), or to provide the most direct access to a specific area. In these examples, the tool projections within the generated overlays can assist the surgeon in positioning the actual tools with increased confidence.

[0206] In yet other examples, the analytical information can be based on an eye position of a user (e.g., a surgeon) determined or sensed via a tracking device within the CASS 100. In these examples, the scaled and oriented simulated projected view can then be output to a projector display device for projection onto patient skin based on the determined eye position, and the projected image can be changed in real-time to be from the perspective of the user.

[0207] In examples in which the patient anatomy includes soft tissues that are analyzed with respect to morphing as explained in detail above, the generated overlay can include the

soft tissue in the morphed state in contrast to the state of the soft tissue depicted in the preoperative imaging. For example, during meniscal repair surgery, there are neurovascular bundles that a surgeon must avoid penetrating. An MRI image may be used to depict the size and position of these anatomical structures, and the current standard of care is to take the MRI with the knee in extension.

[0208] However, the meniscal repair surgical procedure is performed with the knee in flexion, and the neurovascular bundle moves during flexion-extension. With this technology, the 3D anatomical model depicting soft tissue can advantageously be adjusted using machine learning to allow surgeons to visualize various sides and aspects of the soft tissue in the intraoperative morphed state. While some examples of analytical information included in generated overlays and other displays are described and illustrated herein, other types of analytical information can also be used in other exemplary deployments of the disclosed technology.

[0209] Referring now to FIG. 11, a flowchart of an exemplary method for generating merged video data based on registration of anatomical structures and including overlays generated to include analytical information according to a state of a surgical procedure in accordance with an embodiment of this technology is illustrated. In step 1100 in this example, the surgical computer 150 obtains a surgical plan for a surgical procedure, such as a knee or hip arthroplasty, for example. The surgical plan can define steps to be performed automatically by the CASS 100 in order to carry out the surgical procedure, including automated movements of surgical tools that facilitate resection and implantation, for example.

[0210] In step 1102, the surgical computer 150 determines a state of the surgical procedure based on one or more detected anatomical structures in intraoperative video data, such as intraoperative video data captured by an arthroscope as described above with reference to step 1000 of FIG. 10. As explained above with reference to FIG. 10, during the course of a surgical procedure, the disclosed technology can use a machine learning model to detect anatomy represented in a current reference frame within intraoperative video data. By linking the detected anatomical structures and, optionally, tools or other sensed objects within the operating environment, to the overall surgical procedure workflow defined in the surgical plan, the surgical computer 150 can determine the state of surgery. Based on the detected state of a surgical procedure, an overlay with surgical guidance can be generated at the appropriate time in the surgery and output to a display device. For example, during an anterior cruciate ligament (ACL) reconstruction, the surgical plan for tunnel placement could

be visually overlaid automatically on a display screen or head-mounted display once the surgical computer detects that the ACL has been resected and the drilling phase of the procedure has commenced.

[0211] In step 1104, the surgical computer 150 determines whether an overlay is applicable for the particular surgical procedure and at the current time based on the state of the surgical procedure determined in step 1102. The determination in step 1104 can be automatic based on criteria established preoperatively and, optionally, defined in the surgical plan. Alternatively, the determination in step 1104 can be made in response to a manual input indicating a request for guidance information, for example, and other methods for determining whether an overlay is applicable in a current iteration can also be used. If the surgical computer 150 determines that an overlay is not currently applicable, then the No branch is taken back to step 1102, and the surgical computer continues to obtain and analyze intraoperative video data to detect anatomical structures and determine a state of the surgical procedure. However, if the surgical computer 150 determines that an overlay is currently applicable, then the Yes branch is taken to step 1106.

[0212] In step 1106, the surgical computer 150 generates an overlay with analytical information determined from the surgical plan and/or next structure visual and/or textual guidance. In some examples, the surgical computer 150 generates an overlay to include a simulated projected view of one or more tracked and registered anatomical structures, as described above with reference to steps 1002-1006 of FIG. 10, along with analytical and/or guidance information extracted from the obtained surgical plan. The guidance information can include textual directions associated with a current task in the surgical procedure or a visual indication of an anatomical structure corresponding to a subsequent task in the surgical procedure, for example.

[0213] Accordingly, utilizing the workflow recognition of step 1102, an overlay can be generated that directs the surgeon toward the next structure to be viewed. The guidance information could be an arrow added to the overlay that points radially on the arthroscopic view towards the direction of the next structure in the initial diagnostic review checklist for a joint or an audible prompt. In other examples, the guidance information is provided for a significant portion or all of a surgical procedure, particularly for procedures that are new for the user or more complex than a typical case. In these examples, the surgical computer 150 could provide procedural steps, which include both overlays on the screen highlighting the structures to be viewed or worked on next as well as onscreen directions describing the action

to be performed. In this way, the surgical computer 150 can teach surgeons or provide additional confidence with particular surgical procedures.

[0214] In step 1108, the surgical computer 150 outputs merged video data including the intraoperative video data and the generated overlay. In some examples, the overlay is merged at a particular location based on the registration of one or more anatomical structures depicted in the overlay and the intraoperative video data, as described in more detail above. The merged video data can be output to a mixed reality headset worn by a surgeon, for example.

[0215] Optionally, projections of tools can be included in the generated overlay in the surgeon's field of view and can depict an optimal or multiple orientations by which a tool tip can reach a certain area or structure within a joint, which can aid the surgeon in positioning tools with increased accuracy according to a preoperative plan or based on the specific determined state or step in the surgical procedure. Accordingly, with this technology, simulated projected views of detected anatomical structures, analytical information, and/or guidance information can be included in overlays that are merged with intraoperative video data based on an automated registration of the anatomical structures, without fixation of fiducials to patient anatomy, to more effectively assist surgical procedures and improve associated accuracy and outcomes.

[0216] FIG. 12 illustrates a block diagram of an illustrative data processing system 1200 in which aspects of the illustrative embodiments are implemented. The data processing system 1200 is an example of a computer, such as a server or client, in which computer usable code or instructions implementing the process for illustrative embodiments of the present invention are located. In some embodiments, the data processing system 1200 may be a server computing device. For example, data processing system 1200 can be implemented in a server or another similar computing device operably connected to a CASS 100 as described above. The data processing system 1200 can be configured to, for example, transmit and receive information related to a patient and/or a related surgical plan with the CASS 100. Accordingly, the data processing system 1200 can be the surgical computer 150, integral with the surgical computer, or communicably coupled to the surgical computer 150 in some examples. In other examples, the data processing system 1200 can be integral with or communicably coupled to the optical tracking system 115, and other types of deployments can also be used in other examples.

[0217] In the depicted example, data processing system 1200 can employ a hub architecture including a north bridge and memory controller hub (NB/MCH) 1201 and south bridge and input/output (I/O) controller hub (SB/ICH) 1202. Processing unit 1203 (e.g., one

or more central processing units or processor cores), main memory 1204, and graphics processor 1205 can be connected to the NB/MCH 1201. Graphics processor 1205 can be connected to the NB/MCH 1201 through, for example, an accelerated graphics port (AGP).

[0218] In the depicted example, a network adapter 1206 connects to the SB/ICH 1202. An audio adapter 1207, keyboard and mouse adapter 1208, modem 1209, read only memory (ROM) 1210, hard disk drive (HDD) 1211, optical drive (e.g., CD or DVD) 1212, universal serial bus (USB) ports and other communication ports 1213, and PCI/PCIe devices 1214 may connect to the SB/ICH 1202 through bus system 1216. PCI/PCIe devices 1214 may include Ethernet adapters, add-in cards, and PC cards for notebook computers. ROM 1210 may be, for example, a flash basic input/output system (BIOS). The HDD 1211 and optical drive 1212 can use an integrated drive electronics (IDE) or serial advanced technology attachment (SATA) interface. A super I/O (SIO) device 1215 can be connected to the SB/ICH 1202.

[0219] An operating system can run on the processing unit 1203. The operating system can coordinate and provide control of various components within the data processing system 1200. As a client, the operating system can be a commercially available operating system. An object-oriented programming system, such as the Java™ programming system, may run in conjunction with the operating system and provide calls to the operating system from the object-oriented programs or applications executing on the data processing system 1200. As a server, the data processing system 1200 can be an IBM® eServer™ System® running the Advanced Interactive Executive operating system or the Linux operating system. The data processing system 1200 can be a symmetric multiprocessor (SMP) system that can include a plurality of processors in the processing unit 1203. Alternatively, a single processor system may be employed.

[0220] Instructions for the operating system, the object-oriented programming system, and applications or programs are located on storage devices, such as the HDD 1211, and are loaded into the main memory 1204 for execution by the processing unit 1203. The processes for embodiments described herein (e.g., with reference to FIGS. 8-10) can be performed by the processing unit 1203 using computer usable program code, which can be located in a memory (e.g., a non-transitory computer readable medium portion thereof) such as, for example, main memory 1204, ROM 1210, or in one or more peripheral devices.

[0221] A bus system 1216 can be comprised of one or more busses. The bus system 1216 can be implemented using any type of communication fabric or architecture that can provide for a transfer of data between different components or devices attached to the fabric

or architecture. A communication unit such as the modem 1209 or the network adapter 1206 can include one or more devices that can be used to transmit and receive data.

[0222] As described and illustrated in detail above, with this technology, preoperative imaging is used to capture anatomy including bone, cartilage, ligaments, and other anatomical structures, which are segmented into volumes or surfaces to depict the anatomy in three dimensions. During arthroscopic procedures, as the arthroscope is used to view a joint, for example, machine learning model(s) are used to automatically identify the structures depicted in two dimensions in the arthroscopic video data. With the identification of the anatomical structures, this technology advantageously facilitates registration of the anatomical structures depicted in the arthroscopic video data to the three dimensional models generated preoperatively. While preoperative models are used in many of the examples described and illustrated herein, the identification of anatomical structures depicted in the arthroscopic video data intraoperatively using this technology can facilitate registration of the anatomical structures depicted in the arthroscopic video data to three dimensional models generated intraoperatively (e.g., using statistical shape or atlas based models) in other examples. With the orientation of various anatomical structures relative to the arthroscope position, as the anatomical structures move in real-time, they can be tracked.

[0223] Accordingly, this technology advantageously does not require any physical markers placed within or affixed to patient anatomy in order to facilitate surgical tracking, which reduces the risk of damage and complications from surgical procedures. Surgical tracking is also facilitated more efficiently because fiducial markers do not need to be placed within or affixed to anatomical structures and the registration can occur automatically during a diagnostic portion of an arthroscopic procedure.

[0224] While various illustrative embodiments incorporating the principles of the present teachings have been disclosed, the present teachings are not limited to the disclosed embodiments. Instead, this application is intended to cover any variations, uses, or adaptations of the present teachings and use its general principles. Further, this application is intended to cover such departures from the present disclosure that are within known or customary practice in the art to which these teachings pertain.

[0225] In the above detailed description, reference is made to the accompanying drawings, which form a part hereof. In the drawings, similar symbols typically identify similar components, unless context dictates otherwise. The illustrative embodiments described in the present disclosure are not meant to be limiting. Other embodiments may be used, and other changes may be made, without departing from the spirit or scope of the

subject matter presented herein. It will be readily understood that various features of the present disclosure, as generally described herein, and illustrated in the Figures, can be arranged, substituted, combined, separated, and designed in a wide variety of different configurations, all of which are explicitly contemplated herein.

[0226] The present disclosure is not to be limited in terms of the particular embodiments described in this application, which are intended as illustrations of various features. Many modifications and variations can be made without departing from its spirit and scope, as will be apparent to those skilled in the art. Functionally equivalent methods and apparatuses within the scope of the disclosure, in addition to those enumerated herein, will be apparent to those skilled in the art from the foregoing descriptions. It is to be understood that this disclosure is not limited to particular methods, reagents, compounds, compositions or biological systems, which can, of course, vary. It is also to be understood that the terminology used herein is for the purpose of describing particular embodiments only, and is not intended to be limiting.

[0227] With respect to the use of substantially any plural and/or singular terms herein, those having skill in the art can translate from the plural to the singular and/or from the singular to the plural as is appropriate to the context and/or application. The various singular/plural permutations may be expressly set forth herein for sake of clarity.

[0228] It will be understood by those within the art that, in general, terms used herein are generally intended as “open” terms (for example, the term “including” should be interpreted as “including but not limited to,” the term “having” should be interpreted as “having at least,” the term “includes” should be interpreted as “includes but is not limited to,” et cetera). While various compositions, methods, and devices are described in terms of “comprising” various components or steps (interpreted as meaning “including, but not limited to”), the compositions, methods, and devices can also “consist essentially of” or “consist of” the various components and steps, and such terminology should be interpreted as defining essentially closed-member groups.

[0229] In addition, even if a specific number is explicitly recited, those skilled in the art will recognize that such recitation should be interpreted to mean at least the recited number (for example, the bare recitation of “two recitations,” without other modifiers, means at least two recitations, or two or more recitations). Furthermore, in those instances where a convention analogous to “at least one of A, B, and C, et cetera” is used, in general such a construction is intended in the sense one having skill in the art would understand the convention (for example, “a system having at least one of A, B, and C” would include but not

be limited to systems that have A alone, B alone, C alone, A and B together, A and C together, B and C together, and/or A, B, and C together, et cetera). In those instances where a convention analogous to “at least one of A, B, or C, et cetera” is used, in general such a construction is intended in the sense one having skill in the art would understand the convention (for example, “a system having at least one of A, B, or C” would include but not be limited to systems that have A alone, B alone, C alone, A and B together, A and C together, B and C together, and/or A, B, and C together, et cetera). It will be further understood by those within the art that virtually any disjunctive word and/or phrase presenting two or more alternative terms, whether in the description, sample embodiments, or drawings, should be understood to contemplate the possibilities of including one of the terms, either of the terms, or both terms. For example, the phrase “A or B” will be understood to include the possibilities of “A” or “B” or “A and B.”

[0230] In addition, where features of the disclosure are described in terms of Markush groups, those skilled in the art will recognize that the disclosure is also thereby described in terms of any individual member or subgroup of members of the Markush group.

[0231] As will be understood by one skilled in the art, for any and all purposes, such as in terms of providing a written description, all ranges disclosed herein also encompass any and all possible subranges and combinations of subranges thereof. Any listed range can be easily recognized as sufficiently describing and enabling the same range being broken down into at least equal halves, thirds, quarters, fifths, tenths, et cetera. As a non-limiting example, each range discussed herein can be readily broken down into a lower third, middle third and upper third, et cetera. As will also be understood by one skilled in the art all language such as “up to,” “at least,” and the like include the number recited and refer to ranges that can be subsequently broken down into subranges as discussed above. Finally, as will be understood by one skilled in the art, a range includes each individual member. Thus, for example, a group having 1-3 components refers to groups having 1, 2, or 3 components. Similarly, a group having 1-5 components refers to groups having 1, 2, 3, 4, or 5 components, and so forth.

[0232] The term “about,” as used herein, refers to variations in a numerical quantity that can occur, for example, through measuring or handling procedures in the real world; through inadvertent error in these procedures; through differences in the manufacture, source, or purity of compositions or reagents; and the like. Typically, the term “about” as used herein means greater or lesser than the value or range of values stated by 1/10 of the stated values, e.g., $\pm 10\%$. The term “about” also refers to variations that would be recognized by one

skilled in the art as being equivalent so long as such variations do not encompass known values practiced by the prior art. Each value or range of values preceded by the term “about” is also intended to encompass the embodiment of the stated absolute value or range of values. Whether or not modified by the term “about,” quantitative values recited in the present disclosure include equivalents to the recited values, e.g., variations in the numerical quantity of such values that can occur, but would be recognized to be equivalents by a person skilled in the art.

[0233] Various of the above-disclosed and other features and functions, or alternatives thereof, may be combined into many other different systems or applications. Various presently unforeseen or unanticipated alternatives, modifications, variations or improvements therein may be subsequently made by those skilled in the art, each of which is also intended to be encompassed by the disclosed embodiments.

CLAIMS

We claim:

1. A method for registration of arthroscopic video images to preoperative models, the method implemented by one or more surgical computing devices and comprising:
 - applying a machine learning model to diagnostic video data captured via an arthroscope to identify an anatomical structure represented in the diagnostic video data;
 - registering one of a plurality of anatomical structures in a three-dimensional (3D) anatomical model to the anatomical structure represented in the diagnostic video data, wherein the 3D anatomical model is generated from preoperative image data;
 - tracking the anatomical structure intraoperatively based on the registration;
 - generating a simulated projected view of the registered one of the plurality of anatomical structures from the 3D anatomical model based on a determined orientation of the arthroscope during capture by the arthroscope of intraoperative video data; and
 - outputting the simulated projected view scaled and oriented based on one or more landmark features of the anatomical structure extracted from the intraoperative video data.
2. The method of claim 1, further comprising:
 - generating an overlay comprising the scaled and oriented simulated projected view;
 - merging the generated overlay with the intraoperative video data based on the registration to generate merged video data; and
 - outputting to a display device the merged video data.
3. The method of claim 2, further comprising determining a stage of a surgical procedure based on an obtained surgical plan for the surgical procedure and identification of the anatomical structure in the intraoperative video data, wherein the generated overlay further comprises guidance extracted from the obtained surgical plan.
4. The method of claim 3, wherein the guidance comprises one or more of:
 - textual directions associated with a current task in the surgical procedure; or
 - a visual indication of another one of the plurality of anatomical structures corresponding to a subsequent task in the surgical procedure.
5. The method of any of claims 2 to 4, further comprising obtaining an annotated version of the 3D anatomical model or the preoperative image data that identifies an anatomical point

corresponding to a portion of patient anatomy or at least one of the one or more landmark features, wherein the generated overlay further comprises an indication of the anatomical point.

6. The method of any of claims 1 to 5, further comprising training the machine learning model based on additional video data comprising a plurality of image frames each comprising at least one annotated representation of one or more of the plurality of anatomical structures.

7. The method of any of claims 2 to 6, wherein the display device comprises a mixed reality headset and the method further comprises:

tracking one or more of a position or an orientation of the mixed reality headset; and
generating the overlay using a field of view of the arthroscope to determine a local reference frame and based on a known spatial and scale relationship between the arthroscope field of view and another reference frame of the mixed reality headset determined based on the tracking.

8. The method of claim 7, wherein at least a portion of the simulated projected view comprises another one of the plurality of anatomical structures that is occluded in another field of view of the mixed reality headset.

9. The method of any of claims 1 to 8, further comprising:

determining an eye position of a user; and
outputting to a projector the scaled and oriented simulated projected view for projection by the projector onto patient skin based on the determined eye position.

10. The method of any of claims 3 to 4, wherein the generated overlay comprises a depiction of a tool or tool tip oriented according to the surgical plan, according to the determined stage of the surgical procedure, or to facilitate optimal access to a particular portion of patient anatomy.

11. The method of any of claims 1 to 10, wherein the anatomical structure represented in the intraoperative video data comprises soft tissue and the method further comprises:

determining a size and position of a first portion of the soft tissue from the intraoperative video data; and
applying another machine learning model to the 3D anatomical model and the determined size and position to generate a representation of a second portion of the soft tissue

in a morphed state, wherein the simulated projected view comprises the representation of the second portion of the soft tissue in the morphed state.

12. The method of any of claims 1 to 11, further comprising registering an additional one of the plurality of anatomical structures from the 3D anatomical model to the additional one of the plurality of anatomical structures represented in the intraoperative video data based on the registration of the one of the plurality of anatomical structures.

13. The method of any of claims 1 to 12, further comprising:
generating a weighting value for each of a plurality of portions of the 3D anatomical model; and
generating the simulated projected view to include a subset of the plurality of portions based on the weighting values.

14. A non-transitory computer readable medium having stored thereon instructions for registration of arthroscopic video images to preoperative models comprising executable code that, when executed by one or more processors, causes the one or more processors to perform the method of any of claims 1 to 13.

15. A surgical computing device, comprising a non-transitory computer readable medium comprising programmed instructions stored thereon for registration of arthroscopic video images to preoperative models and one or more processors coupled to the non-transitory computer-readable medium and configured to execute the stored programmed instructions to perform the method of any of claims 1 to 13.

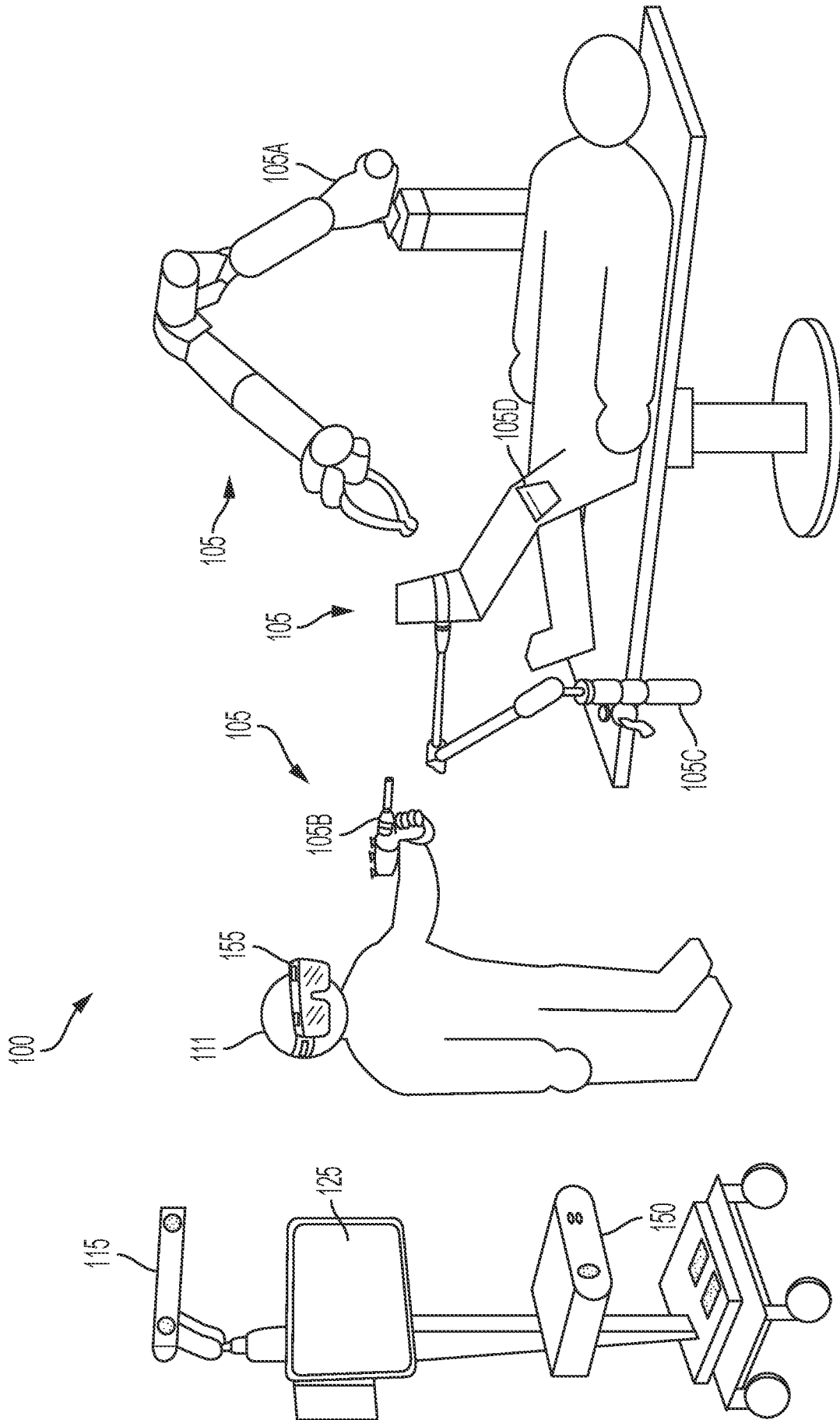

FIG. 1

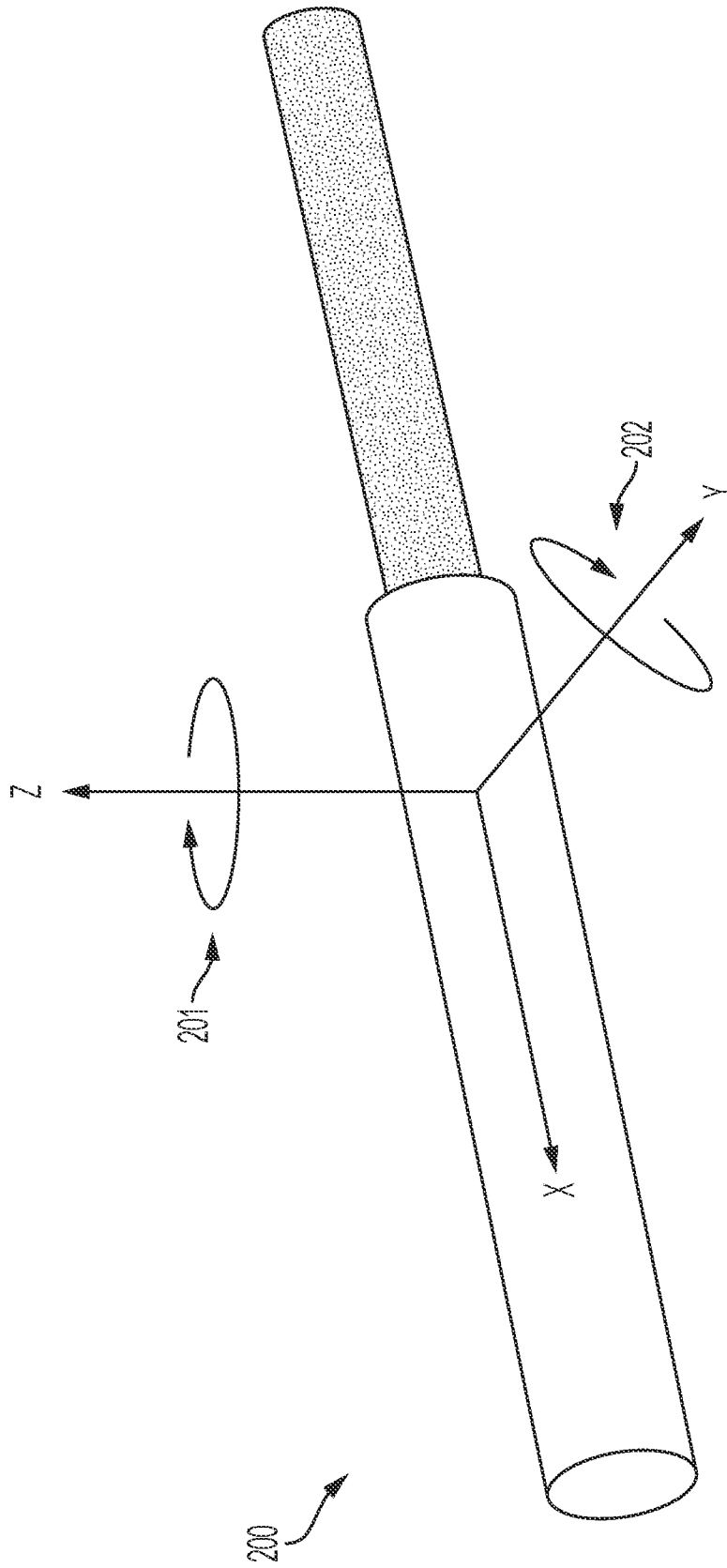

FIG. 2

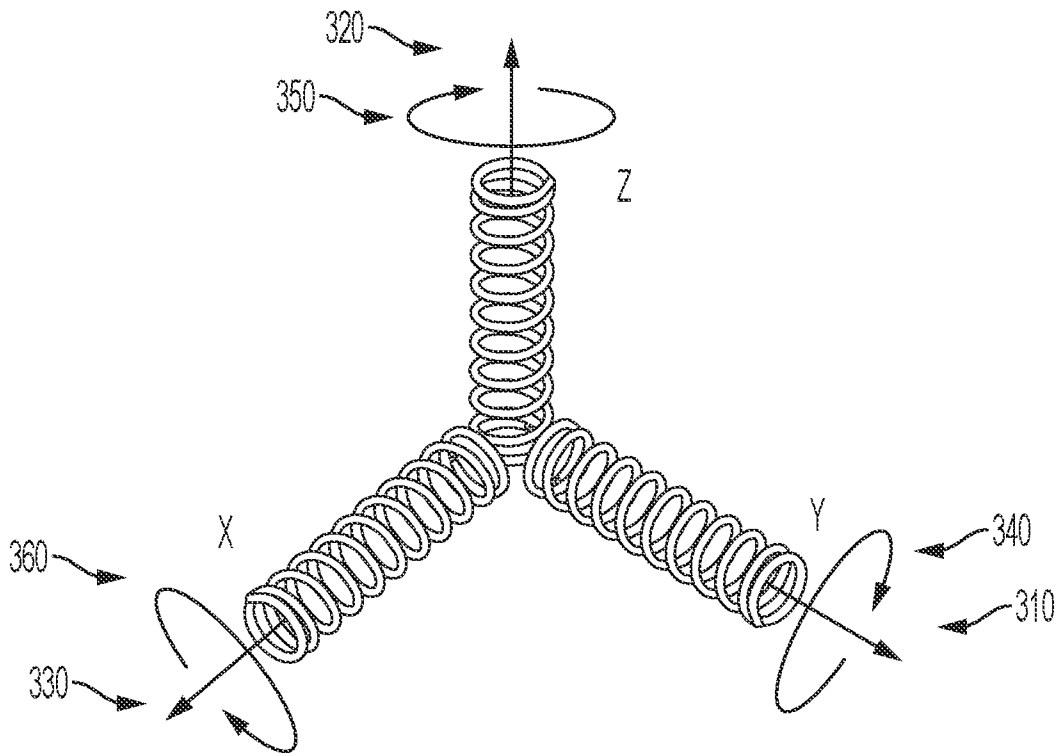

FIG. 3A

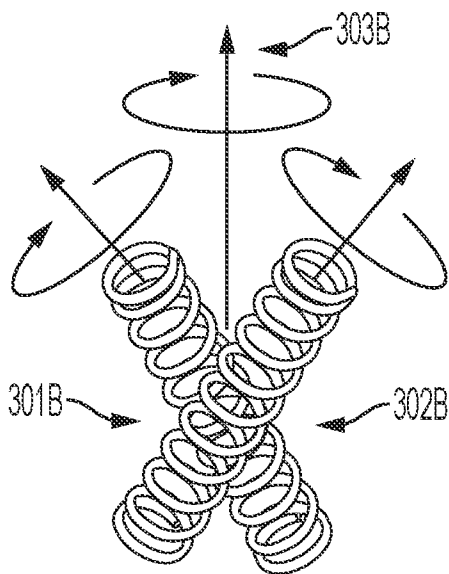

FIG. 3B

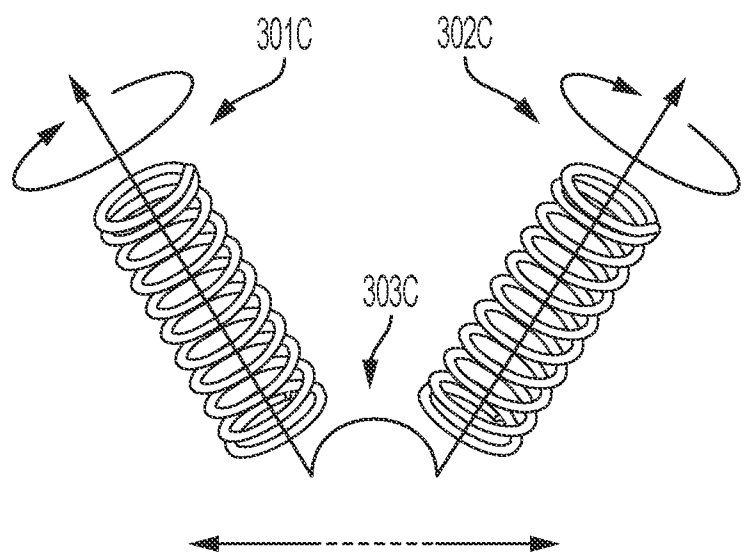

FIG. 3C

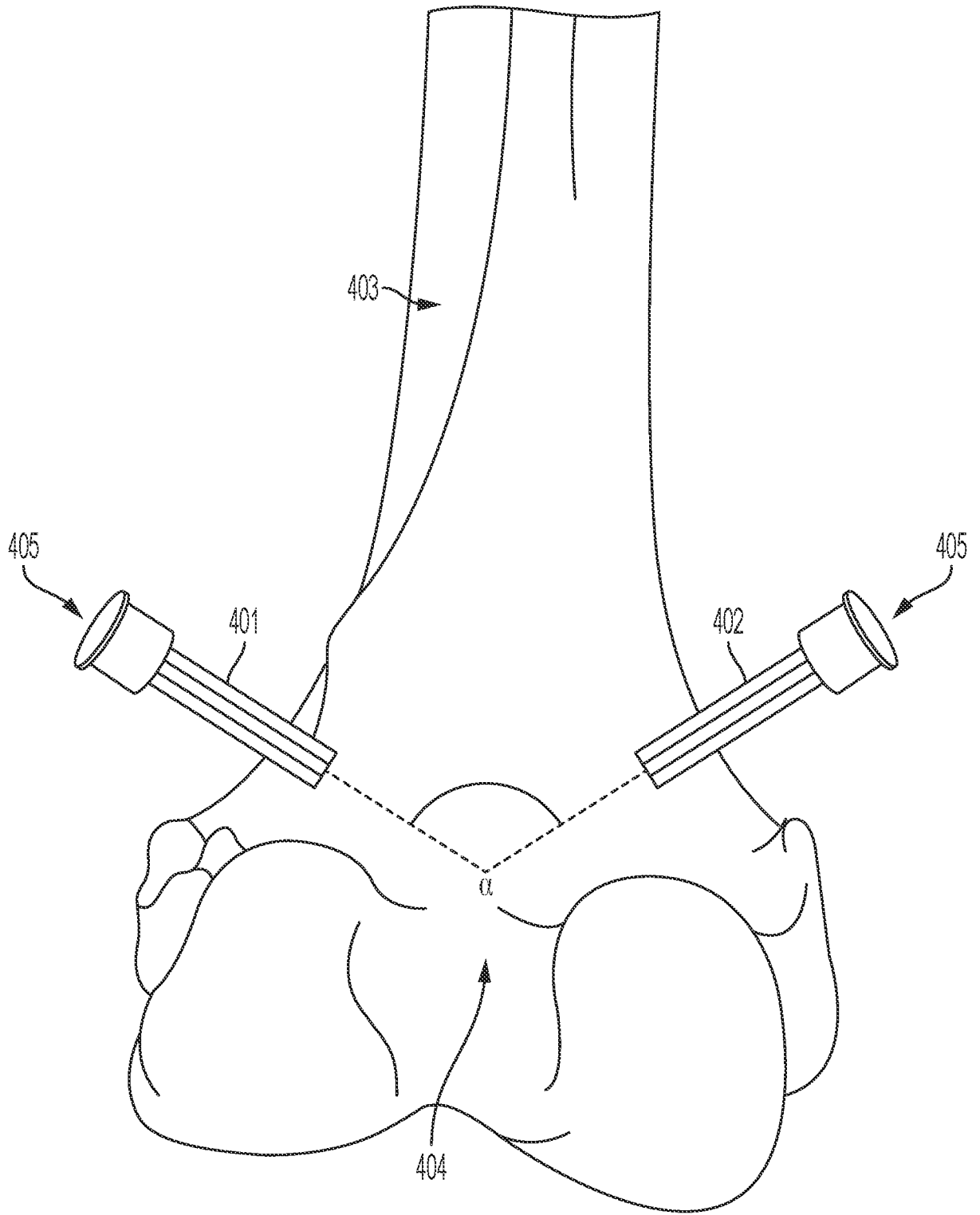

FIG. 4

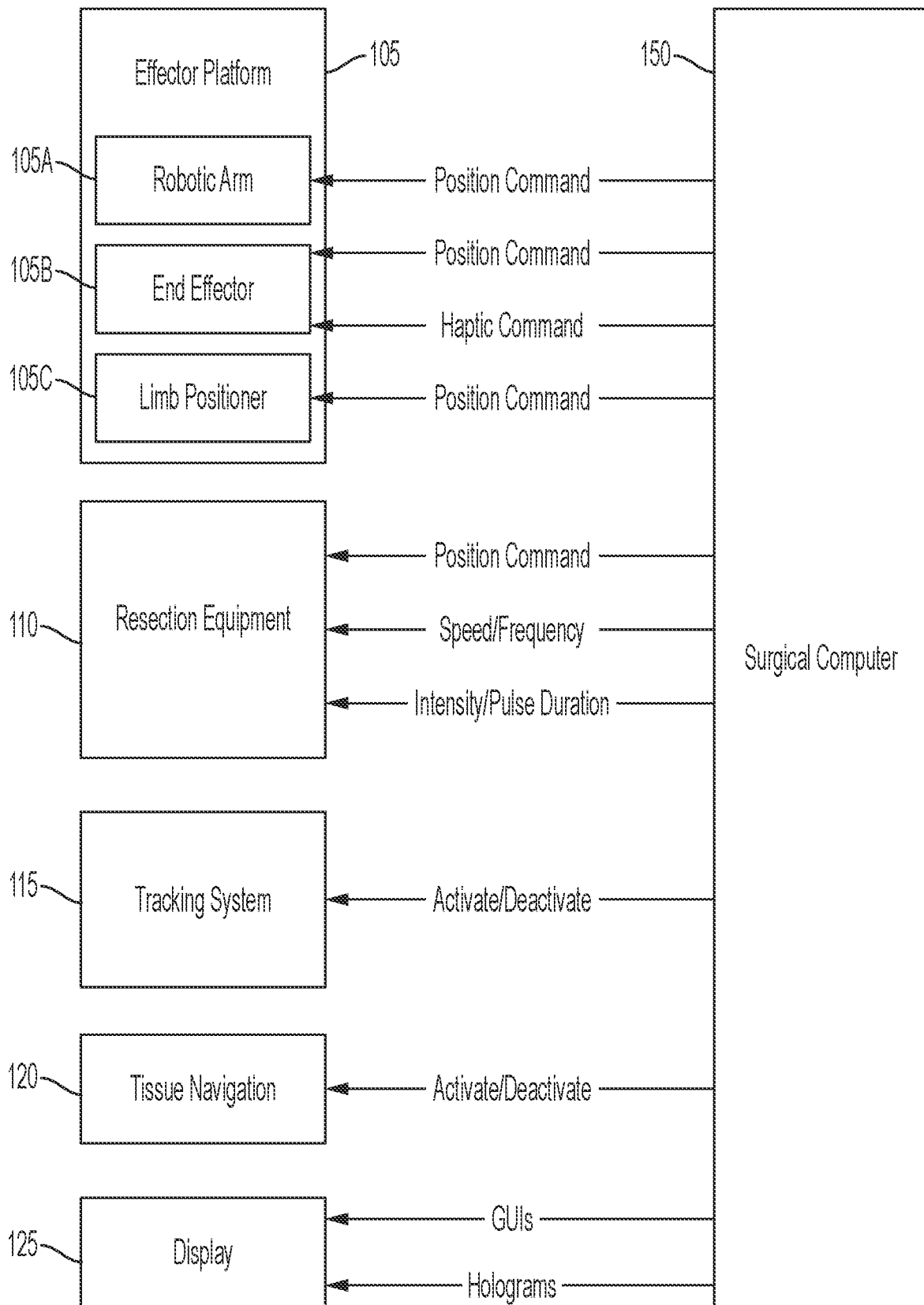

FIG. 5A

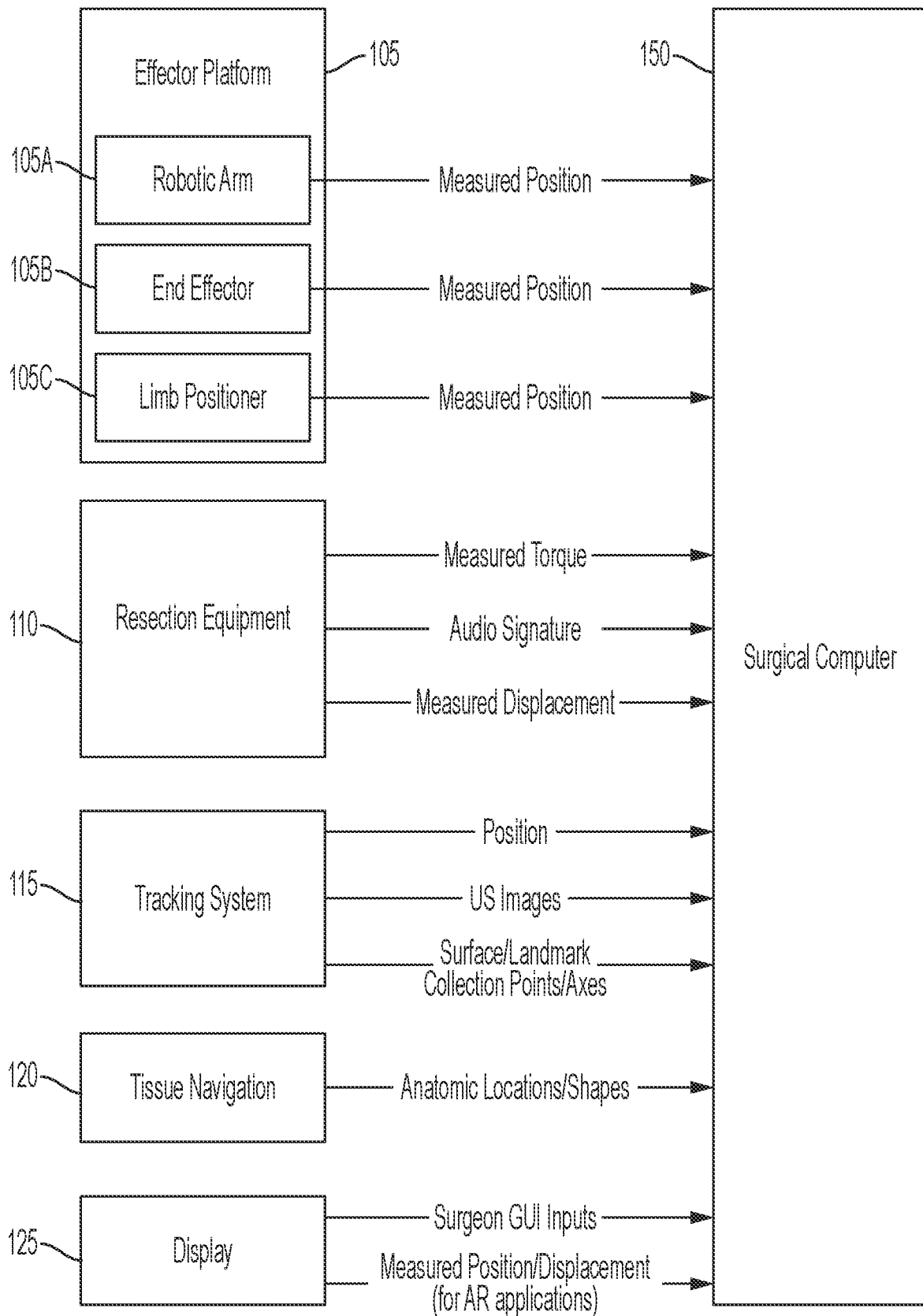

FIG. 5B

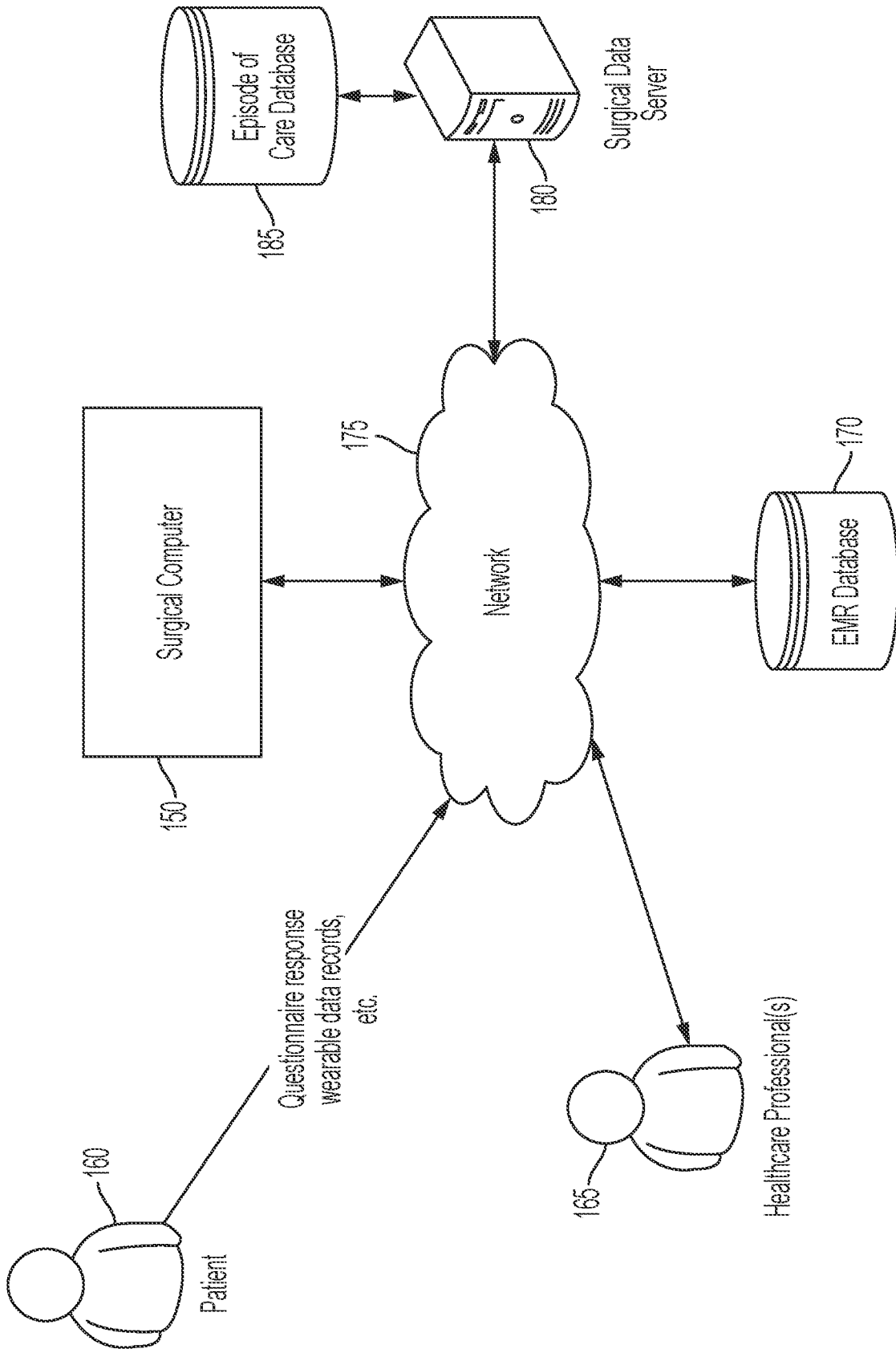

FIG. 5C

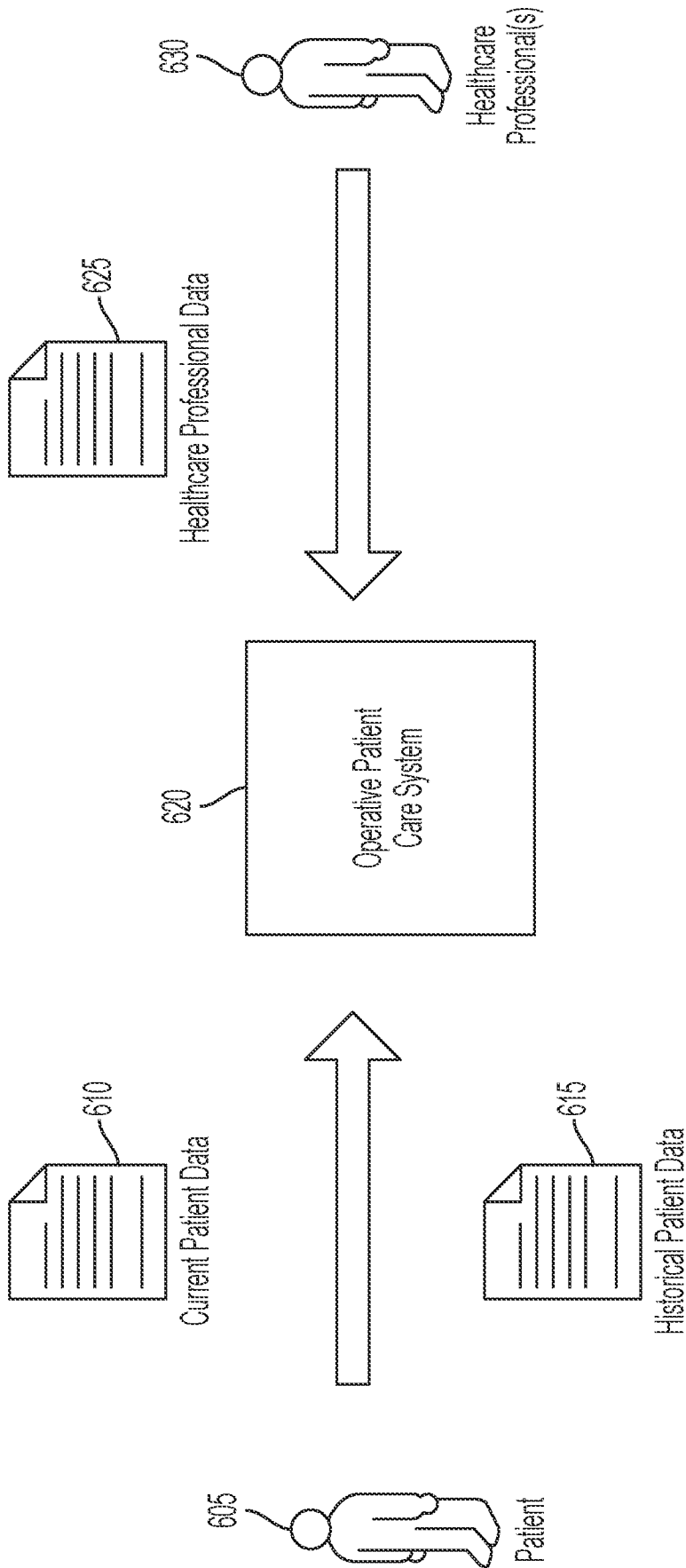

FIG. 6

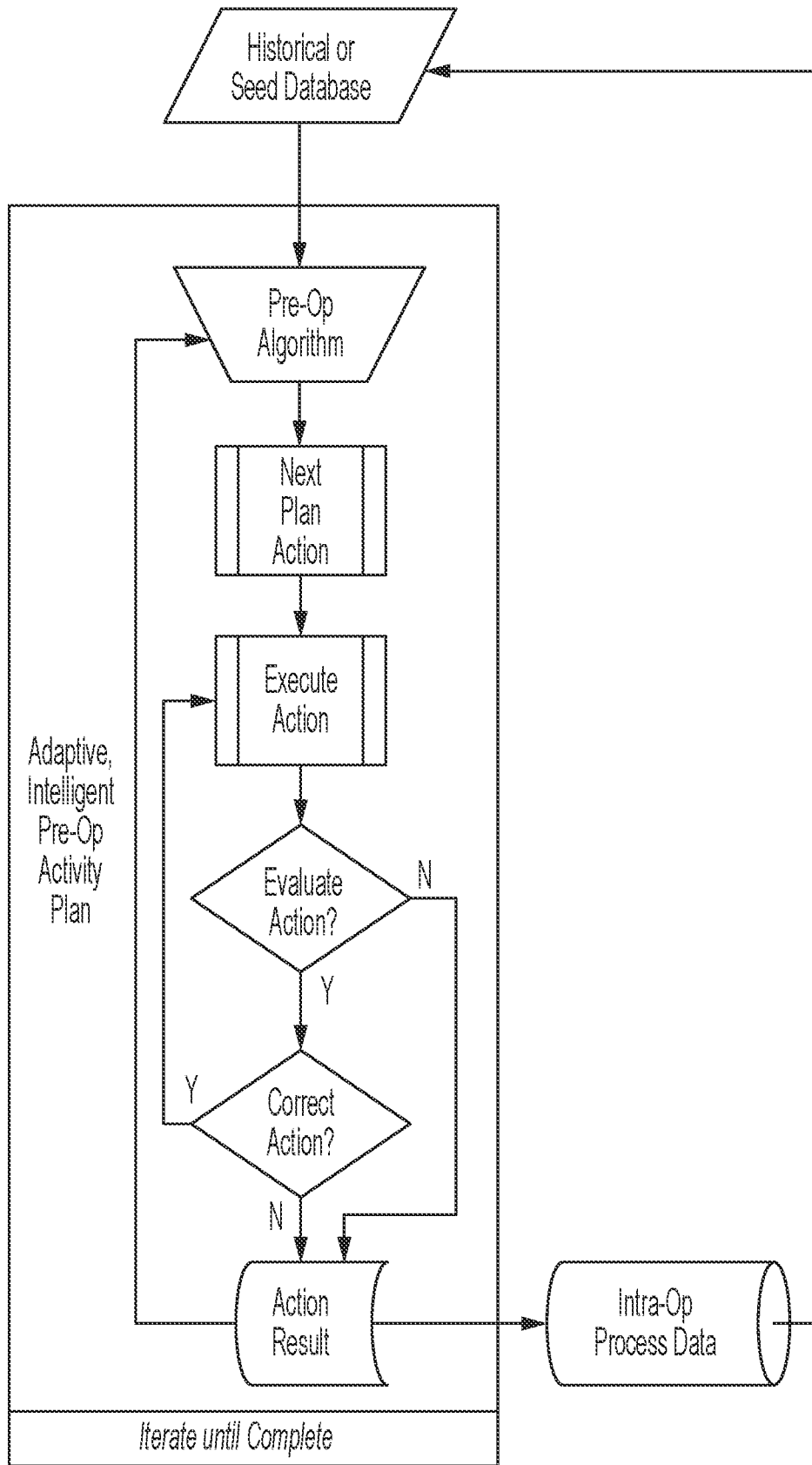

FIG. 7A

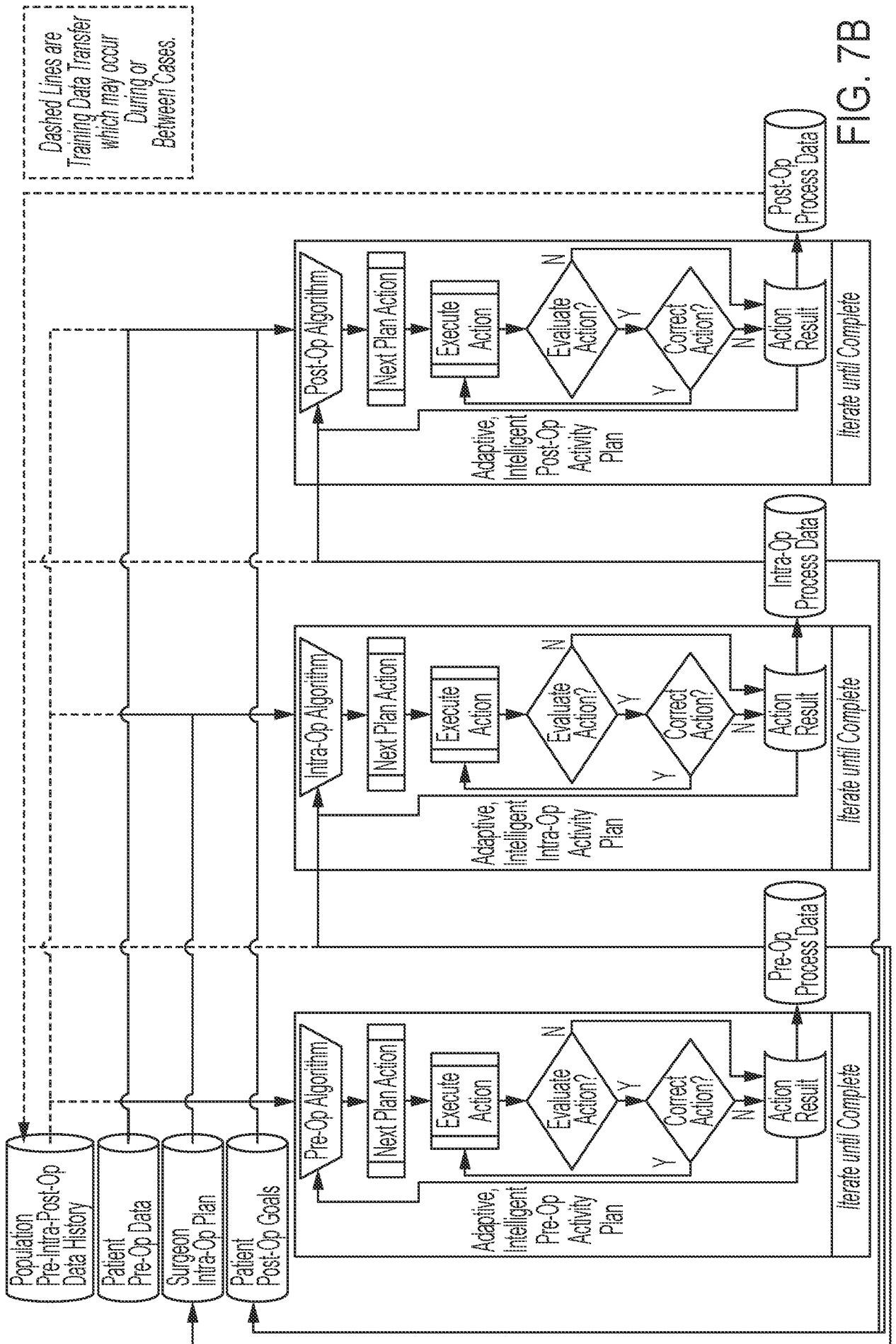





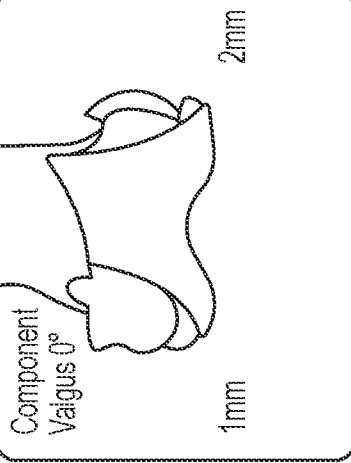
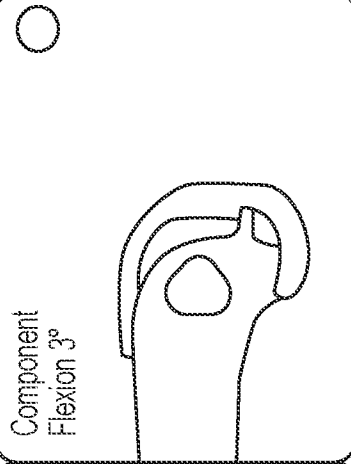
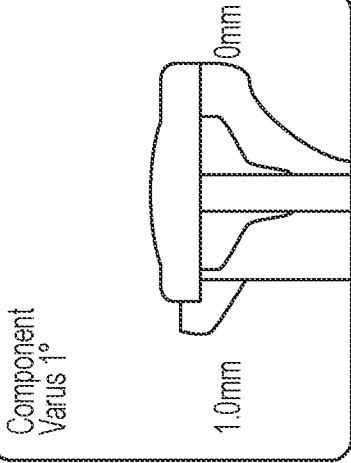
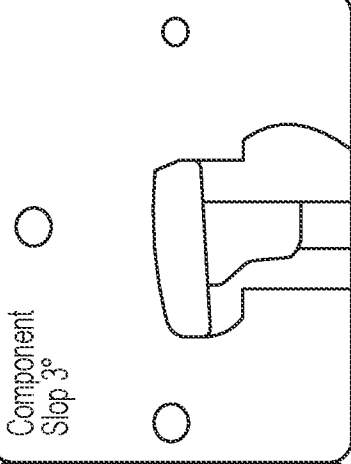



FIG. 7B



Implant Placement 



    

 <p>Component Valgus 0° 1mm</p>	 <p>Component Flexion 3°</p>	 <p>Component Varus 1° 1.0mm</p>	 <p>Component Slop 3°</p>
--	--	--	--





Smith+Nephew Journey II CR 

Femur Size  SIZE 5 

Tibia Size  SIZE 6 

Thickness 3 mm 

Cross Section
Plan Femur
Plan Tibia
Other Options

T+0.5 minutes

FIG. 7C

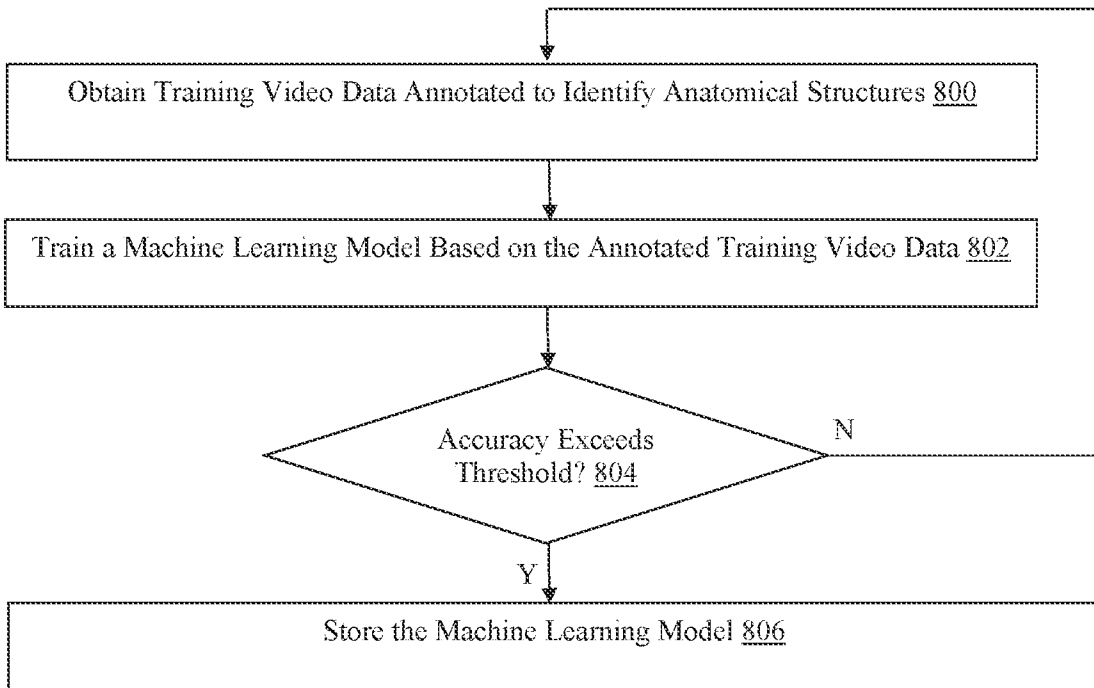

FIG. 8

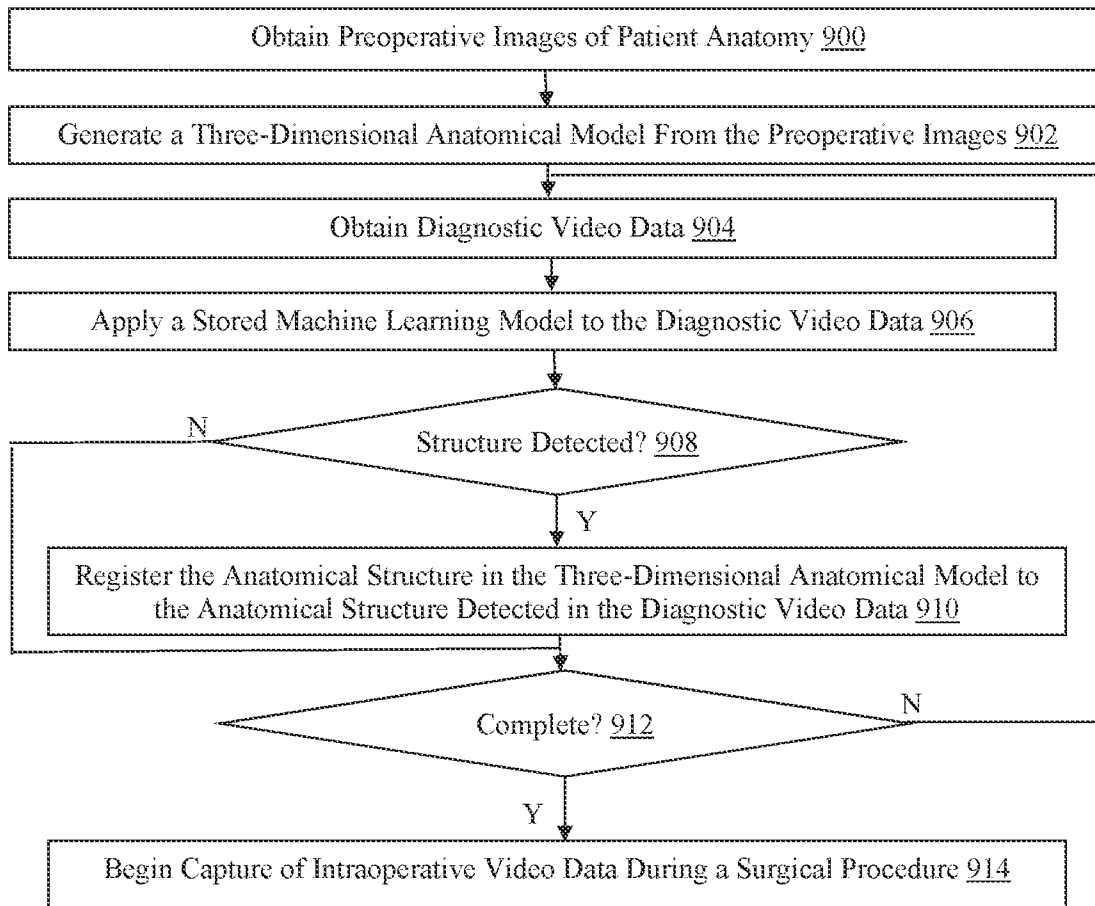
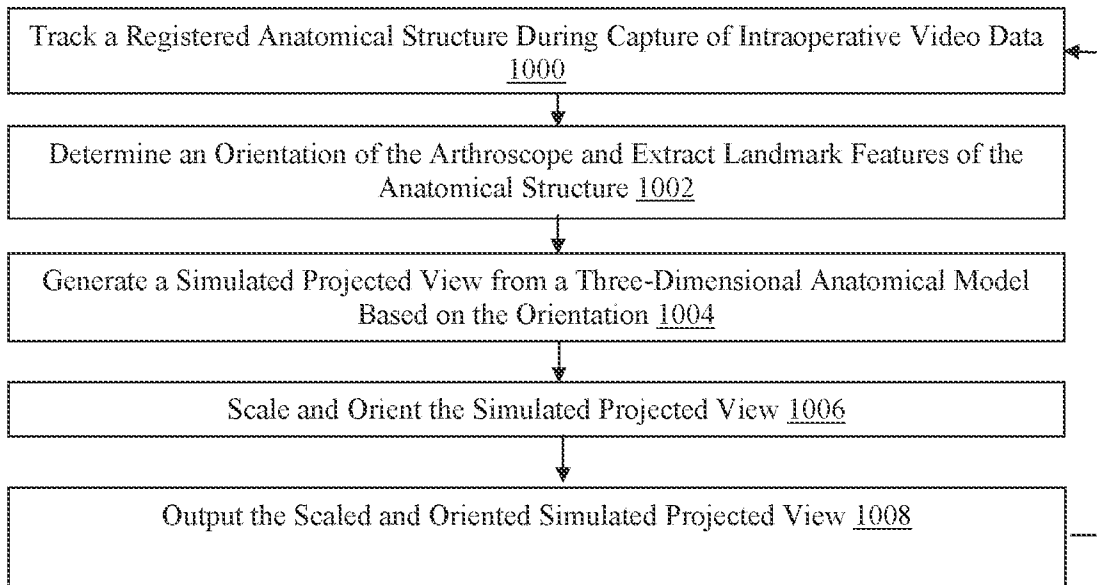

FIG. 9

**FIG. 10**

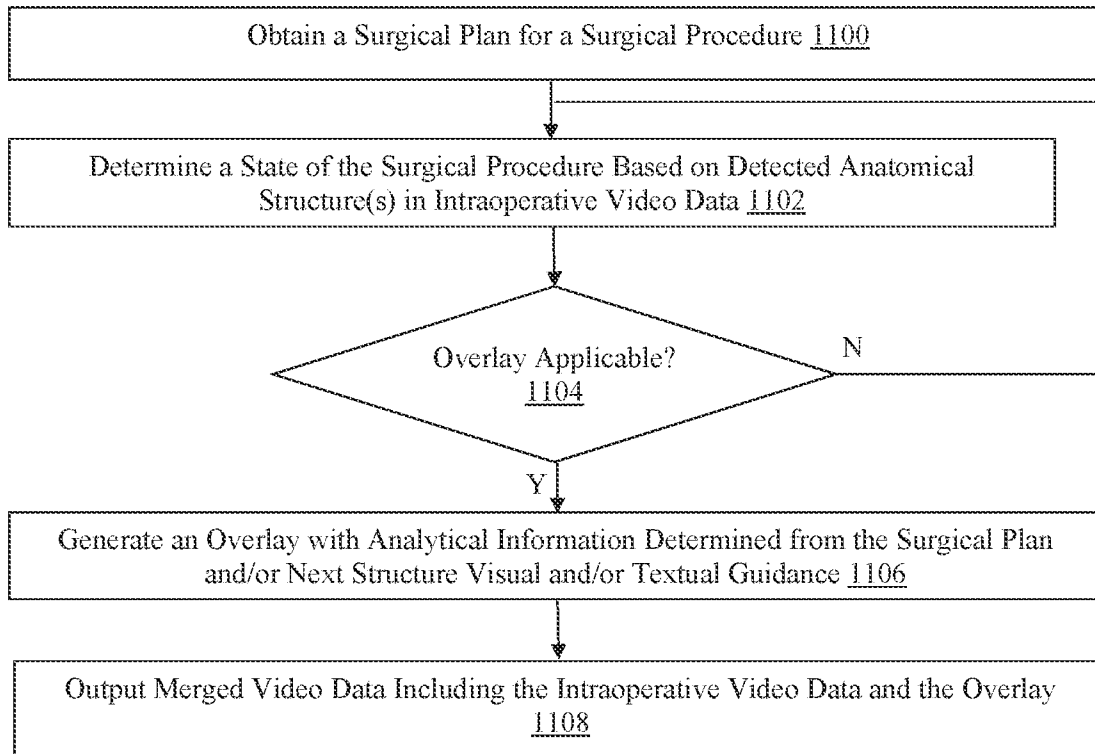

FIG. 11

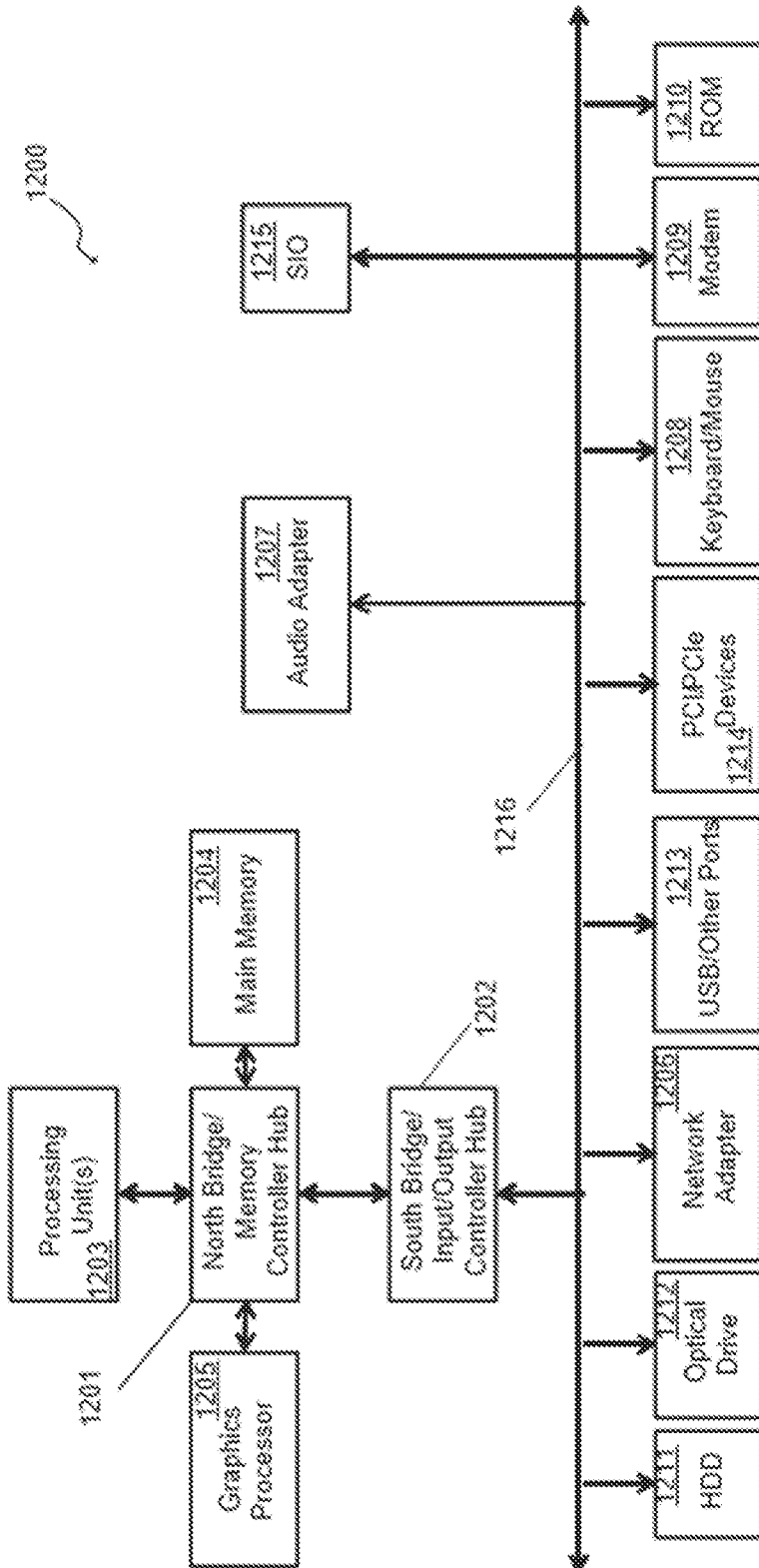

FIG. 12

INTERNATIONAL SEARCH REPORT

International application No
PCT/US2021/037580

A. CLASSIFICATION OF SUBJECT MATTER
INV. A61B34/10 A61B34/20
ADD.

According to International Patent Classification (IPC) or to both national classification and IPC

B. FIELDS SEARCHED

Minimum documentation searched (classification system followed by classification symbols)
A61B G06N

Documentation searched other than minimum documentation to the extent that such documents are included in the fields searched

Electronic data base consulted during the international search (name of data base and, where practicable, search terms used)

EPO-Internal, WPI Data

C. DOCUMENTS CONSIDERED TO BE RELEVANT

Category*	Citation of document, with indication, where appropriate, of the relevant passages	Relevant to claim No.
X	<p>RODRIGUES PEDRO ET AL: "Deep segmentation leverages geometric pose estimation in computer-aided total knee arthroplasty", HEALTHCARE TECHNOLOGY LETTERS, vol. 6, no. 6, 6 December 2019 (2019-12-06), pages 226-230, XP006088042, DOI: 10.1049/HTL.2019.0078 page 226, column 2, lines 8-11, 20-24, 35-37 page 227, column 2, lines 1-3 page 229, column 1, lines 7-9 page 229, column 2, lines 4-6 figure 5</p> <p style="text-align: center;">----- -/--</p>	14,15

Further documents are listed in the continuation of Box C. See patent family annex.

* Special categories of cited documents :

<p>"A" document defining the general state of the art which is not considered to be of particular relevance</p> <p>"E" earlier application or patent but published on or after the international filing date</p> <p>"L" document which may throw doubts on priority claim(s) or which is cited to establish the publication date of another citation or other special reason (as specified)</p> <p>"O" document referring to an oral disclosure, use, exhibition or other means</p> <p>"P" document published prior to the international filing date but later than the priority date claimed</p>	<p>"T" later document published after the international filing date or priority date and not in conflict with the application but cited to understand the principle or theory underlying the invention</p> <p>"X" document of particular relevance; the claimed invention cannot be considered novel or cannot be considered to involve an inventive step when the document is taken alone</p> <p>"Y" document of particular relevance; the claimed invention cannot be considered to involve an inventive step when the document is combined with one or more other such documents, such combination being obvious to a person skilled in the art</p> <p>"&" document member of the same patent family</p>
---	---

Date of the actual completion of the international search	Date of mailing of the international search report
27 September 2021	07/10/2021

Name and mailing address of the ISA/ European Patent Office, P.B. 5818 Patentlaan 2 NL - 2280 HV Rijswijk Tel. (+31-70) 340-2040, Fax: (+31-70) 340-3016	Authorized officer Cutrone, Annarita
--	---

INTERNATIONAL SEARCH REPORT

International application No.
PCT/US2021/037580

Box No. II Observations where certain claims were found unsearchable (Continuation of item 2 of first sheet)

This international search report has not been established in respect of certain claims under Article 17(2)(a) for the following reasons:

1. Claims Nos.: **1-13**
because they relate to subject matter not required to be searched by this Authority, namely:
see FURTHER INFORMATION sheet PCT/ISA/210

2. Claims Nos.:
because they relate to parts of the international application that do not comply with the prescribed requirements to such an extent that no meaningful international search can be carried out, specifically:

3. Claims Nos.:
because they are dependent claims and are not drafted in accordance with the second and third sentences of Rule 6.4(a).

Box No. III Observations where unity of invention is lacking (Continuation of item 3 of first sheet)

This International Searching Authority found multiple inventions in this international application, as follows:

1. As all required additional search fees were timely paid by the applicant, this international search report covers all searchable claims.

2. As all searchable claims could be searched without effort justifying an additional fees, this Authority did not invite payment of additional fees.

3. As only some of the required additional search fees were timely paid by the applicant, this international search report covers only those claims for which fees were paid, specifically claims Nos.:

4. No required additional search fees were timely paid by the applicant. Consequently, this international search report is restricted to the invention first mentioned in the claims; it is covered by claims Nos.:

Remark on Protest

- The additional search fees were accompanied by the applicant's protest and, where applicable, the payment of a protest fee.
- The additional search fees were accompanied by the applicant's protest but the applicable protest fee was not paid within the time limit specified in the invitation.
- No protest accompanied the payment of additional search fees.

FURTHER INFORMATION CONTINUED FROM PCT/ISA/ 210

Continuation of Box II.1

Claims Nos.: 1-13

Claims 1-13 relate to subject-matter considered by this Authority to be covered by the provisions of Rule 39.1(iv) PCT as it relates to a surgical method. According to claim 1, the method "for registration of arthroscopic video images to preoperative models" comprises the step of "tracking the anatomical structure intraoperatively based on the registration", which is directed towards a surgical step for the following reasons: (i) the tracking of registered anatomical structures in intraoperative video ([0194], first sentence) implies a movement of a tool, i.e. the arthroscope ([0193], first sentence) within the body that involves substantial health risk; (ii) the term "intraoperatively" implies that said step is performed during a surgical operation, hence, it is directed towards a surgical step. Claims 2-13 are drafted as dependent method claims that are directed to a surgical treatment by virtue of their dependency on claim 1. Therefore, claims 1-13 have not been searched.

INTERNATIONAL SEARCH REPORT

International application No
PCT/US2021/037580

C(Continuation). DOCUMENTS CONSIDERED TO BE RELEVANT		
Category*	Citation of document, with indication, where appropriate, of the relevant passages	Relevant to claim No.
A	WO 2020/086403 A1 (SMITH & NEPHEW INC [US]; SMITH & NEPHEW PTE LTD [SG] ET AL.) 30 April 2020 (2020-04-30) the whole document	14,15
A	----- PEPE ANTONIO ET AL: "A Marker-Less Registration Approach for Mixed Reality-Aided Maxillofacial Surgery: a Pilot Evaluation", JOURNAL OF DIGITAL IMAGING, SPRINGER-VERLAG, CHAM, vol. 32, no. 6, 4 September 2019 (2019-09-04), pages 1008-1018, XP036931246, ISSN: 0897-1889, DOI: 10.1007/S10278-019-00272-6 [retrieved on 2019-09-04] the whole document	14,15
A	----- THORSTEN M SEYLER ET AL: "Arthroscopic-Assisted Minimally Invasive Total Knee Arthroplasty", ARTHROSCOPY, RAVEN PRESS, NEW YORK, NY, US, vol. 27, no. 2, 1 October 2010 (2010-10-01), pages 290-293, XP028362249, ISSN: 0749-8063, DOI: 10.1016/J.ARTHRO.2010.10.003 [retrieved on 2010-10-27] the whole document -----	14,15

INTERNATIONAL SEARCH REPORT

Information on patent family members

International application No

PCT/US2021/037580

Patent document cited in search report	Publication date	Patent family member(s)	Publication date
WO 2020086403	A1	NONE	30-04-2020