



US 20050067523A1

(19) **United States**

(12) **Patent Application Publication**

Zach et al.

(10) **Pub. No.: US 2005/0067523 A1**

(43) **Pub. Date: Mar. 31, 2005**

(54) **APPARATUS FOR DEFLECTING OR
INVERTING MOVING WEBS**

Publication Classification

(75) Inventors: **Mark J. Zach**, Northfield, MN (US);
Leonard M. Volin, Stillwater, MN (US)

(51) **Int. Cl.⁷ B65H 23/32; B65H 23/26**

(52) **U.S. Cl. 242/615.2; 242/615.21**

Correspondence Address:

**3M INNOVATIVE PROPERTIES COMPANY
PO BOX 33427
ST. PAUL, MN 55133-3427 (US)**

(57) **ABSTRACT**

A slat roller wherein the translation of slats permits a non-normal angle of incidence of a moving web to the longitudinal axis of the roller. The non-normal angle of incidence and the translation of the slats permit the axial movement of the web when the web is in contact with slats of the roller. One or more of the slat rollers may be employed in a system for inverting a moving web of indefinite length material.

(73) Assignee: **3M Innovative Properties Company**

(21) Appl. No.: **10/676,188**

(22) Filed: **Sep. 30, 2003**

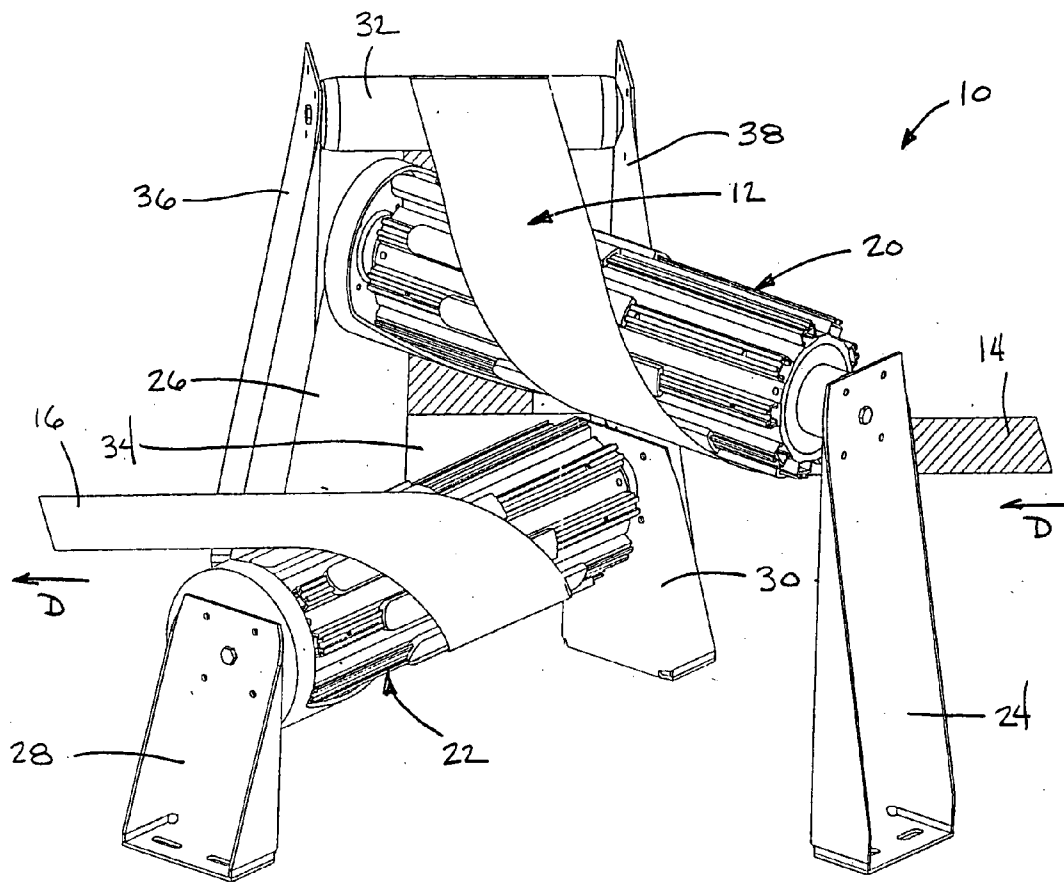

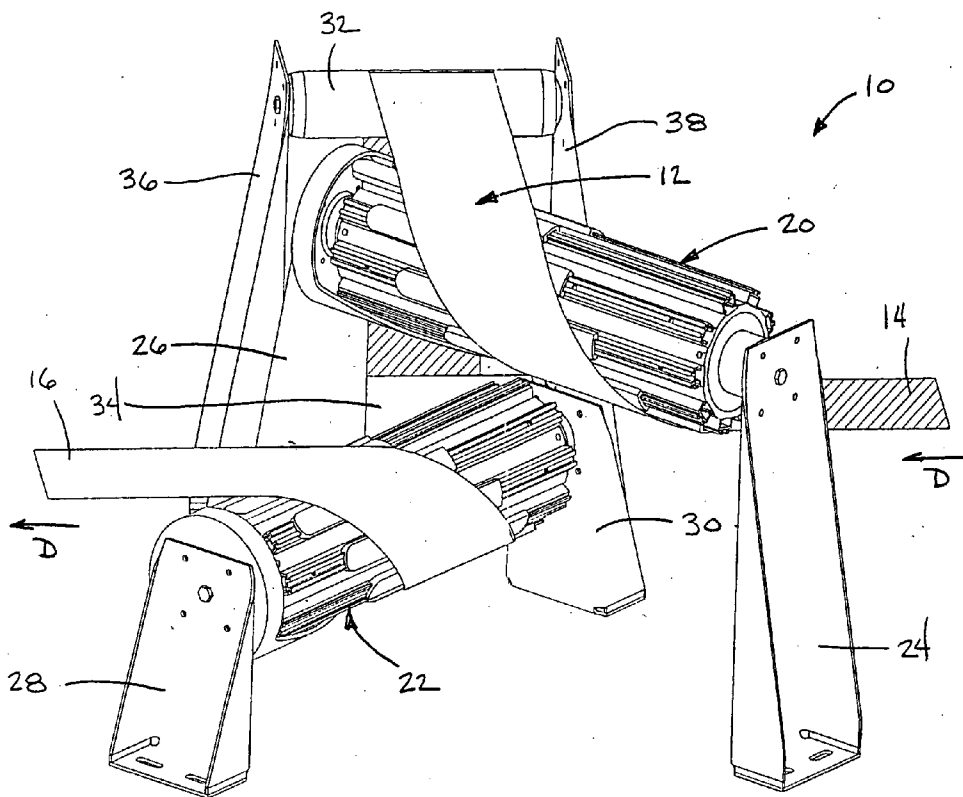

Fig. 1

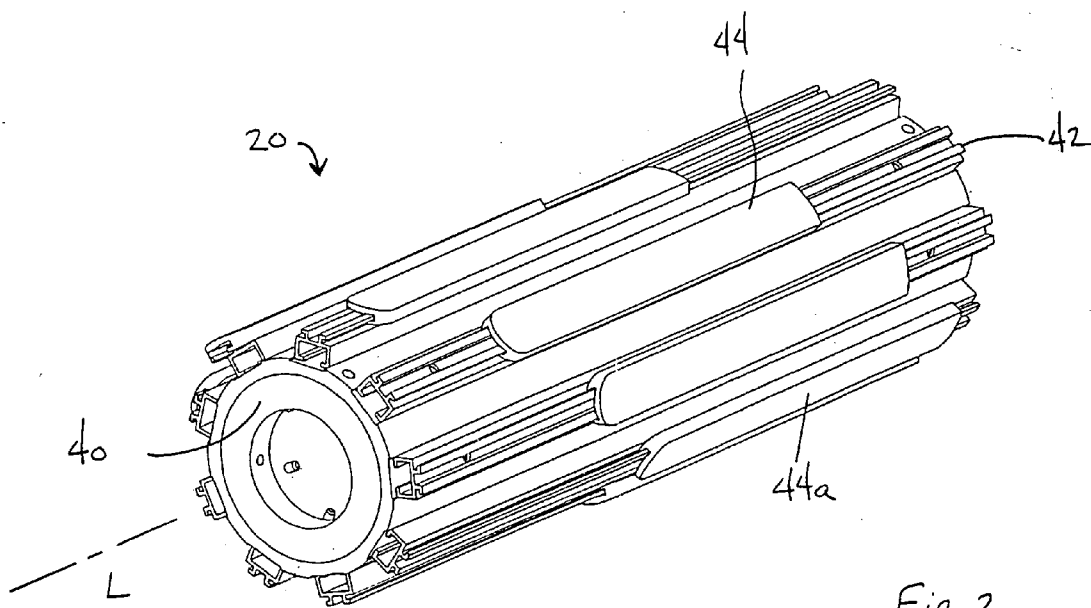

Fig. 2

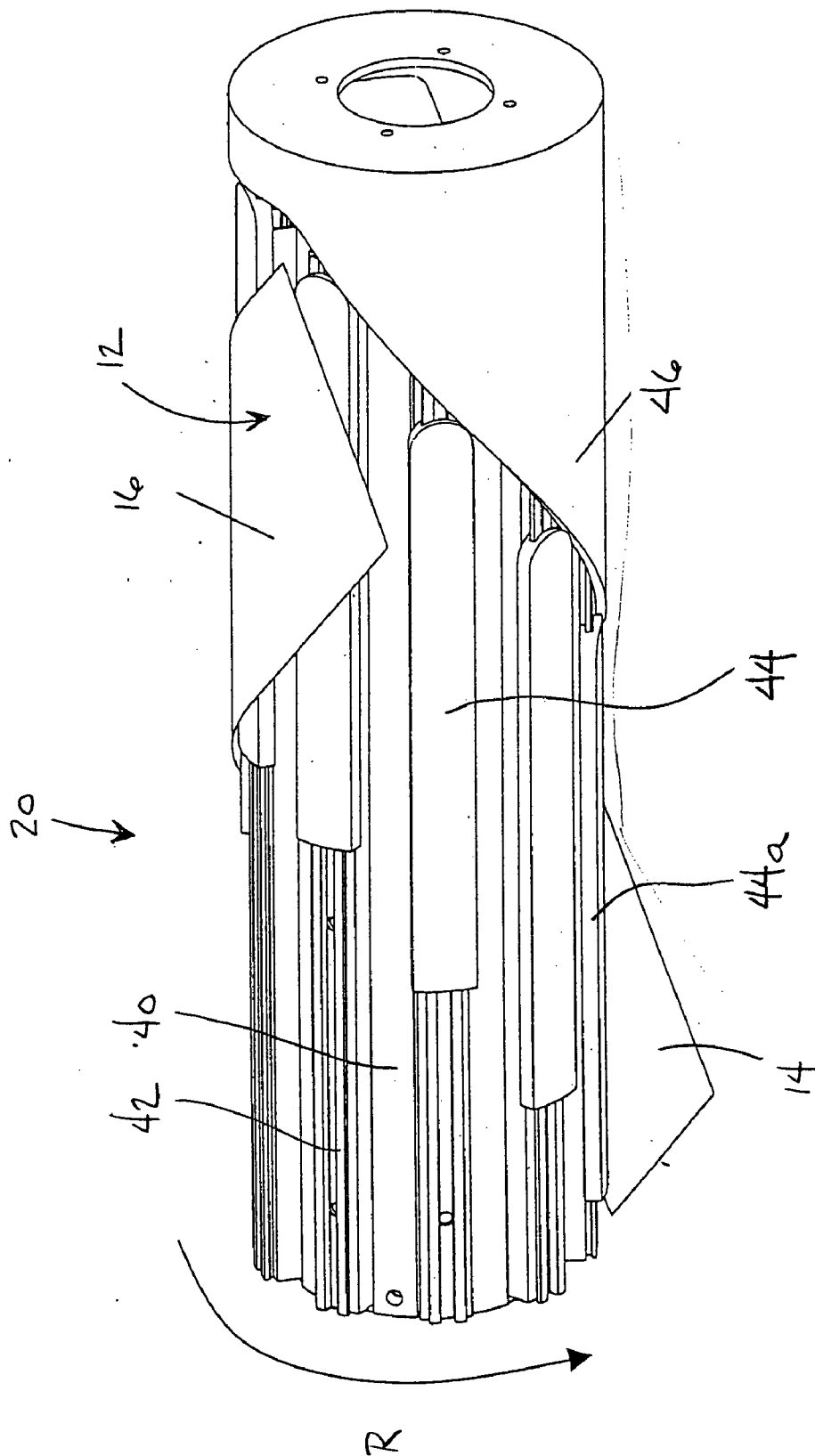

Fig. 3

APPARATUS FOR DEFLECTING OR INVERTING MOVING WEBS

TECHNICAL FIELD

[0001] The present invention relates to controlling the motion of moving webs of indefinite length, and more particularly to a device for changing the direction or inverting such webs.

BACKGROUND

[0002] Numerous commercial products incorporate material that has undergone processing in the form of a web of indefinite length material during some stage of its manufacture. When such webs are being processed, it is frequently desirable to divert the web to a different direction, or to invert the web so the opposite side of the web is facing upwards to receive e.g. the application of a coating. For many applications it is conventional to wrap the web partially around one or more non-rotating air flotation device called an "air bar" or an "air turn" in order to divert or invert the web. However, in some circumstances the use of an air bar is inconvenient. For example the web may be too heavy, too porous, or too textured for the needed air cushion to develop. In such circumstances, it is known that apparatuses that have, e.g. guide rotors disposed in spiral curves may be employed. However, the known alternatives are bulky and complicated to construct.

SUMMARY OF THE INVENTION

[0003] The present invention provides a slat roller for controlling the movement of moving web of indefinite length material. Such a slat roller has a roller body having a longitudinal axis. A plurality of slats are mounted on a circumference of the roller body in such a fashion that the slats may translate from a first position in a direction parallel to the longitudinal axis of the roller body. A slat repositioning device is included for moving the slats towards the first position when the slats are not in contact with the moving web. The translation of the slats permits a non-normal angle of incidence of the web to the longitudinal axis. A non-normal angle of incidence to the longitudinal axis indicates that the centerline of the web is not at about 90 degrees with the longitudinal axis of the roller as the web makes contact with the slats of the roller.

[0004] In another aspect the present invention provides a system for inverting a moving web of indefinite length material, the heart of which is a pair of slat rollers. Each slat roller has a roller body having a longitudinal axis. A plurality of slats are mounted on the circumference of the roller body in such a fashion that the slats may translate from a first position in a direction parallel to the longitudinal axis of the roller body. In a preferred embodiment, the system also has a first and a second roller for conveying the moving web between the first and the second slat rollers, such that when the moving web, starting in a first orientation, is directed around the first slat roller, the first and second idler rollers and the second slat roller, it emerges in a second orientation which is inverted from the first orientation.

[0005] In a most preferred embodiment of the system the two slat rollers are rotatably mounted with their longitudinal axes generally perpendicular to each other. Also, in most convenient embodiments, the roller body is rotated and the

slats are translated longitudinally in a passive manner in contact with the moving web. In these embodiments, the slat rollers each include a slat repositioning device for moving the slats towards the first position when the slats are no longer contacting the moving web. The translation of the slats permits a non-normal angle of incidence of the web to the longitudinal axis of the roller.

BRIEF DESCRIPTION OF THE DRAWINGS

[0006] In the several figures of the attached drawing, like parts bear like reference numerals, and:

[0007] **FIG. 1** illustrates a perspective view of an exemplary web handling system incorporating the apparatus according to the present invention;

[0008] **FIG. 2** illustrates a detail view of a slat roller in isolation; and

[0009] **FIG. 3** illustrates a reverse angle view of the slat roller of **FIG. 2**, with a section of web in position, and with a stationary return cam being used to move the slats back to a starting position.

DETAILED DESCRIPTION

[0010] Referring now to **FIG. 1**, a perspective view of an exemplary web handling system **10** according to the present invention is illustrated. The system **10** is shown guiding a segment of a web **12** of indefinite length material, the web **12** having a first side **14** and a second side **16** and moving in direction "D". The system **10** includes a first slat roller **20** and a second slat roller **22**, with the first slat roller **20** conveniently rotatably mounted on supports **24** and **26** and the second slat roller **22** conveniently mounted on supports **28** and **30**. The system **10** also includes a first idler roller **32** and a second idler roller **34** for conveying the moving web between the first and the second slat rollers **20** and **22**. The first idler roller **32** and the second idler roller **34** are conveniently rotatably mounted on supports **36** and **38**. It will be noted that first and the second slat rollers **20** and **22** are mounted with their longitudinal axes generally perpendicular to each other in this Figure, and this is often convenient in many preferred embodiments of the invention. It will also be observed in the depicted embodiment the web **12** has been inverted: after passing through system **10**, first side **14** which had been face up is been placed face down.

[0011] The non-normal angle of incidence of the web to the longitudinal axis of the slat roller is suitable for either inverting a web or changing the orientation, or direction of the web. The non-normal angle of incidence and the translation of the slats permit the axial movement of the web when the web is in contact with slats of the roller.

[0012] Referring now to **FIG. 2**, a detail view of slat roller **20** is illustrated in isolation. The slat roller **20** has a roller body **40** having a longitudinal axis "L," and having a plurality of slat supports **42** thereon. A plurality of slats **44** is mounted on the slat supports **42** in such a fashion that the slats **44** may translate from a first position (slat **44a** is in the first position) along the slat supports in a direction parallel to the longitudinal axis "L".

[0013] In the depicted embodiment, the preferred slat supports **42** have been conveniently constructed of extruded material that has been attached to the roller body **40** using

mechanical fasteners. Extruded aluminum is considered particularly suitable for this purpose. Also in the depicted embodiment, the slats **44** have been conveniently constructed from extruded or machined material having a cross-section adapted to slidably interlock with the slat supports **42**. Slats **44** may be prepared from many different materials, and slats **44** made of Delrin brand acetal polymer are considered particularly suitable for many common applications. It will be apparent to the ordinary artisan that numerous mechanical expedients are suitable for providing sliding engagement between the slats **44** and the slat supports **42**. In particular, the slats supports **42** needn't extend above the surface of the roller body **40**, but may be slots provided beneath the surface. Those skilled in the art recognize that other conventional means of mounting slats onto a circumference of the roller may be utilized in the present invention.

[0014] In accordance with the present invention, a slat repositioning device may be utilized to move the slat toward an original position on the roller when the slats are no longer in contact with the moving web. Slat repositioning devices may include either mechanical devices, pneumatic devices, electrical devices, or combinations thereof. Non-limiting examples of such devices would include stationary cams, linear motors, or air cylinders. Those skilled in the art are capable of selecting a suitable repositioning device based on web properties, process requirements, and process environments.

[0015] Referring now to **FIG. 3**, a reverse angle view of the slat roller **20** of **FIG. 2** is illustrated with a section of web **12** in position. In this view it can be appreciated that when the slat roller **20** is rotated passively in contact with moving web **12** in rotation direction "R", then stationary cam **46** serves to move each slat **44** in turn back towards its first position (slat **44a** is in first position).

[0016] The depicted embodiment of slat roller **20** includes nine slat supports **42** each supporting one slat **44**. At least two slats **44** must be provided, but it is frequently desirable to provide more, particularly when the system **10** is operating with the slat rollers **20** and **22** being passively driven by contact with the moving web **12**. It will be appreciated that although providing more slats **44** and slat supports **42** will increase the cost and complexity of a slat roller **20**, the greater number of slats reduces an individual slat's contact time with the web thereby providing a greater time in which the slat may translate to its original position. The diameter of the roller body **40** and its length will also be seen to be variables affecting the amount of force needed for the return of the slats **44** to first position **44a** against the stationary cam **46**.

[0017] The preferred embodiment of the present invention has been described utilizing the moving web as the primary driving force for imparting the rotation of the roller or rollers. Those skilled in the art recognize that driven rollers may be desirable for certain webs or web processing environments. Various modifications and alterations of the present invention will be apparent to those skilled in the art without departing from the scope and spirit of this invention, and it should be understood that this invention is not limited to the illustrative embodiments set forth herein.

1. A slat roller for controlling the movement of moving web of indefinite length material, comprising:

- a rotatable roller body having a longitudinal axis,
- a plurality of slats mounted on a circumference of the roller body in such a fashion that the slats may translate from a first position in a direction parallel to the longitudinal axis when the slats are in contact with the moving web, and
- a slat repositioning device for moving the slats towards the first position when the slats are not in contact with the moving web, the translation of slats permitting a non-normal angle of incidence of the web to the longitudinal axis.

2. A system for inverting a moving web of indefinite length material, comprising:

employing at least one slat roller of claim 1.

3. A system for inverting a moving web of indefinite length material, comprising:

- a first slat roller of claim 1 and a second slat roller of claim 1;
- one or more rollers for conveying the moving web between the first slat roller and the second slat roller, such that

when the moving web, starting in a first orientation, is directed around the first slat roller, the one or more rollers and the second slat roller, it emerges in a second orientation which is inverted from the first orientation.

4. The system for inverting a moving web of indefinite length material according to claim 3 wherein the first and the second slat rollers are rotatably mounted with their longitudinal axes generally perpendicular to each other.

5. The system for inverting a moving web of indefinite length material according to claim 3 wherein each of the first and the second slat roller further comprises a stationary cam for moving the slats towards the first position when the roller is turned passively by contact with the moving web.

* * * * *