

REPUBLIC OF SOUTH AFRICA  
PATENTS ACT, 1978**PUBLICATION PARTICULARS AND ABSTRACT**

(Section 32(3)(a) – Regulation 22(1)(g) and 31)

OFFICIAL APPLICATION NO.

LODGING DATE

ACCEPTANCE DATE

21	01	20010527
----	----	----------

22	18 JAN 2001
----	-------------

43	19-1-2001
----	-----------

INTERNATIONAL CLASSIFICATION

NOT FOR PUBLICATION

51	A61B
----	------

CLASSIFIED BY: SPOOR AND FISHER
---------------------------------

FULL NAMES OF APPLICANTS

71	1. COLEMAN, JAMES E 2. CUMMINS, CHRISTY 3. MARTIN, CHRIS 4. ANTHONY, THOMAS 5. MORRIS, SEAN
----	---

FULL NAMES OF INVENTORS

72	1. COLEMAN, JAMES E 2. CUMMINS, CHRISTY 3. MARTIN, CHRIS 4. ANTHONY, THOMAS 5. MORRIS, SEAN
----	---

EARLIEST PRIORITY CLAIMED

COUNTRY	
33	IE

NUMBER	
31	S2000/0722

DATE	
32	8 SEP 2000

TITLE OF INVENTION

54	SURGICAL STAPLER
----	------------------

57	ABSTRACT (NOT MORE THAT 150 WORDS)
----	------------------------------------

NUMBER OF SHEETS	47
------------------	----

If no classification is finished, Form P.9 should accompany this form.  
The figure of the drawing to which the abstract refers is attached.

20010527

ABSTRACT

A surgical stapler comprises a shaft 12 and a tube 92 slidable axially within the shaft between a forward position wherein one end of the tube projects beyond a free end of the shaft to enter a puncture site in a blood vessel and a rearward position (Fig. 8) wherein the end of the locator tube is retracted within the shaft. A surgical staple 40 straddles the tube 92 and is slidable thereon forwardly towards an anvil 24 against which the staple may be deformed to staple together the opposite edges of the puncture site. A cam mechanism drives the staple forwardly along the tube 92 into deforming engagement with the anvil and at the same time retracts the tube into the shaft in time to allow the legs of the staple to close onto the puncture site.

20010527

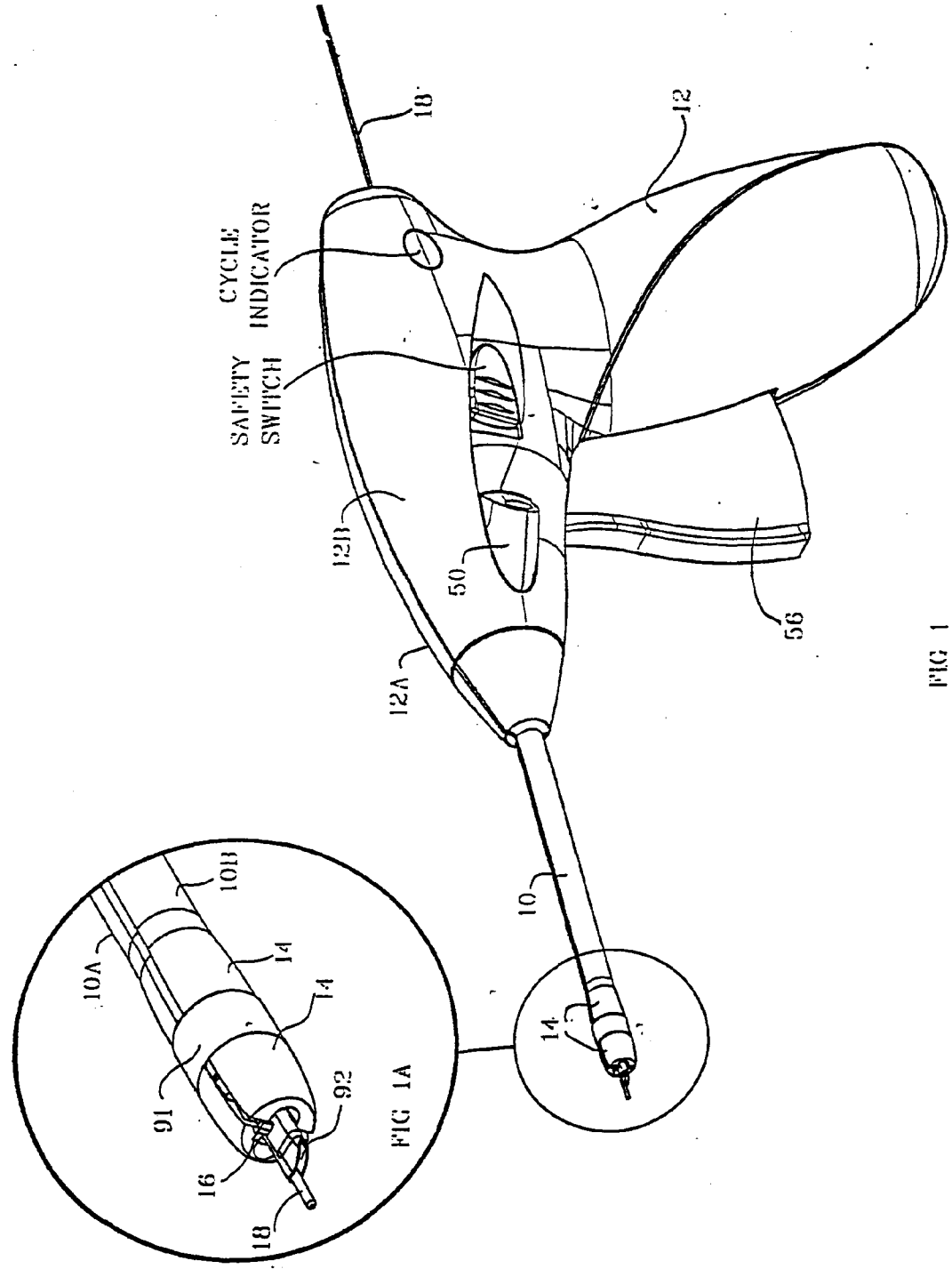

FIG 1

## SURGICAL STAPLER

The present invention relates to an instrument, herein called a surgical stapler, for closing a puncture in a liquid-carrying vessel by applying a staple across the puncture so as to effect a closure. The invention relates particularly to surgical staplers for closing punctures in blood vessels.

10 When performing catheterisation procedures, such as angiography or angioplasty, a catheter is generally introduced into the vascular system by first penetrating the skin, underlying tissues and blood vessel with a sharpened hollow needle. Next, a  
15 guidewire is commonly inserted through the lumen of the hollow needle and is caused to enter the selected blood vessel. Subsequently the needle is typically stripped off the guidewire and a combination of a dilator and/or introducer (or an introducer alone) are fed over the  
20 guidewire and pushed through the skin to enter the blood vessel. The guidewire can then be removed and a desired catheter to carry out the procedure is fed through the lumen of the introducer and advanced through the vascular system until the working end of  
25 the catheter is appropriately positioned. Following the conclusion of the catheterisation procedure the working catheter will be withdrawn and subsequently the dilator and/or introducer will also be removed from the wound. Following this procedure the vessel puncture

must be closed in order to prevent loss of blood through the puncture hole.

Typically the wound is closed by maintaining external  
5 pressure over the vessel until the puncture naturally seals. This procedure can take approximately 30 minutes with the length of time usually being greater if the patient is hypertensive or anticoagulated. The procedure can also be uncomfortable for the patient and  
10 involves costly professional time on the part of the hospital staff. Other pressure techniques such as pressure bandages, sandbags or clamps have been employed but these also involve ensuring the patient remains motionless for an extended period of time and  
15 is monitored to ensure the effectiveness of the procedure.

A number of devices have been developed in recent times which provide an obstruction in the area of the  
20 puncture in order to prevent bleeding. For example, US Patents 4,852,568 and 4,890,612 disclose a device which utilises a collagen plug which when placed at the blood vessel opening absorbs body fluids, swells and affects a seal. Other plug like devices, for example  
25 US 5,222,974 and US 5,282,827, describe a plug and anchor device, the anchor being positioned inside the vessel and the collagen plug outside the vessel thereby sandwiching the puncture between both and effecting a closure.

WO 98/17179 discloses a surgical stapler having a blood locator tube adjacent the stapling head. A guidewire passes through an opening at the end of the tube and up  
5 through a hollow bore in the tube, so that the stapler can be fed onto the guidewire and down onto the puncture site. When the device reaches the puncture site, the tip of the tube enters the blood flow within the artery and blood passes through the tube and out of  
10 the distal end at a point visible to the clinician. The clinician can then actuate the stapling mechanism in the knowledge that the stapling head is at the puncture site in the arterial wall.

15 It is an object of the present invention to provide an instrument for closing a puncture in a liquid-carrying vessel by stapling.

According to the present invention there is provided a  
20 surgical stapler comprising a shaft, a locator slidable axially of the shaft between a forward position wherein the locator projects beyond a free end of the shaft to enter a puncture site in a liquid-carrying vessel in a human or animal, thereby to locate the free end of the  
25 shaft at the puncture site, and a rearward position wherein the locator is retracted relative to the shaft, a surgical staple straddling the locator and slidable forwardly thereon, said staple having forwardly pointing legs disposed respectively on opposite sides

of the locator, an anvil against which the staple may be deformed to staple together opposite edges of the puncture site, and an actuator for driving the staple forwardly along the locator into deforming engagement  
5 with the anvil and for retracting the locator in coordination with the movement of the staple such that the locator means is withdrawn from between the legs of the staple in time to allow the legs of the staple to staple together opposite edges of the puncture site.

10

In another aspect the invention provides a method of stapling closed a puncture site in a liquid-carrying vessel in a human or animal body, comprising the steps of:

15       introducing a staple-forming mechanism to the location of the vessel;

          positioning the staple forming mechanism at the puncture site by means of a locator adjacent the staple forming mechanism, said locator sensing the position of  
20 the puncture site upon entering into the vessel, and thereby providing an indication of the positioning of the staple forming mechanism at the puncture site;

          forming a staple to thereby close the puncture site, and simultaneously withdrawing the locator from  
25 the puncture site, whereby the locator is fully withdrawn from the vessel by the time the staple is fully formed to close the puncture site.

Preferably, the step of simultaneously forming a staple and withdrawing the locator is effected by operating a single control on a stapler actuating mechanism associated with the staple forming mechanism.

5

An embodiment of the invention will now be described, by way of example, with reference to the accompanying drawings, in which:

10 Fig. 1 is a perspective view of an embodiment of a surgical stapler according to the invention;

Fig. 1(A) is an enlarged perspective view of the free end of the shaft of the stapler of Fig. 1;

15

Fig. 2 is a perspective view of the stapler of Fig. 1 with the left hand side handle removed;

20 Fig. 3 is a perspective view of the stapler of Fig. 1 with the right hand side handle and shaft removed;

Fig. 4 is an exploded perspective view of the components seen in Fig. 3 further omitting the right hand side handle;

25

Fig. 5 is an exploded perspective view of the internal components at the free end of the shaft and omitting the left hand side of the shaft;



Fig. 6 is a perspective view of the internal components at the free end of the shaft in the pre-fire position and omitting the left hand side of the shaft;

5 Fig. 7 is a side elevation of the components of Fig. 6 in the pre-fire position;

Fig. 8 is a front elevation of the components of Fig. 6 in the pre-fire position;

10

Fig. 9 is a perspective view of the internal components of the free end, showing the position of the components in mid-cycle with fully formed staple;

15 Fig. 10 is a side elevation of the components of Fig. 9 in the post-fire position;

Fig. 11 is a perspective view of the blood locator tube with exploded views of the front and rear portions,

20 Fig. 11A and Fig. 11B respectively;

Fig. 12 is a side sectional elevation of the front portion of an alternative embodiment of the blood locator tube of the stapler, taken horizontally along  
25 the longitudinal axis of the tube;

Fig. 13 is a perspective view of the front portion of the blood locator tube shown in Fig. 12;

Fig. 14 is an enlarged perspective view of the staple;

Fig. 15 is an enlarged perspective view of the cam mechanism; and

5

Fig. 16 is a side elevation of the cam mechanism.

Referring to the drawings, the stapler comprises a rigid shaft 10 extending from a moulded plastic housing 12 shaped in the form of a pistol-like handle. The shaft 10, which is hollow to accommodate various moving components, to be described, comprises right and left hand sides 10A, 10B respectively, which are secured together at the distal free end by a metal retaining ring 91 and along the proximal end captured within the handle 12. Likewise, the housing 12 comprises left and right hand sides 12A, 12B respectively.

The major part of the exposed length of the shaft 10 has a constant circular cross-section, but at its free end the shaft 10 has a portion 14 of increased diameter having a "bullet" profile. One end of this bullet portion 14 is tapered down toward a staple exit slot 16 while the other end is tapered down to the remaining section of the shaft, which extends back into the housing 12. The ratio of the diameter or maximum width of the bullet portion 14 to the diameter of minimum width of the remaining section of exposed shaft is approximately 5:4. Metal retaining ring 91 sits flush

with the surface of the bullet portion 14, to ensure atraumatic entry into tissue.

The reason for the bullet profile is so that the shaft  
5 10 is as atraumatic as possible during introduction to  
the body to minimise the amount of force and tissue  
dilation required when tracking the device over a  
guidewire 18 and onto the surface of a blood vessel  
adjacent a puncture hole, as will be described. In an  
10 alternative embodiment, not shown, the bullet portion  
14 is oval in cross-section with the major axis of the  
oval being coincident with the staple exit slot 16, so  
as to minimise the circumferential length for a given  
staple width.

15

The bullet portion 14 of the shaft 10 houses the staple  
and staple delivery mechanism, 40, 54, 24, 36, 34 and  
92, Fig. 6, which is operated, via rod-like actuating  
members slidable in the shaft 10, by a trigger-operated  
20 cam mechanism 22 in the handle housing 12.

The staple delivery mechanism comprises an anvil 24  
(see especially Fig. 5) having a pair of upstanding  
fingers 24A at the front and a pair of downwardly  
25 inclined tilt arms 24B at the rear. The anvil 24 is  
tiltably mounted in the bullet portion 14 by a pair of  
wings 26 which are pivotable in recesses 28 in the  
right hand side 10A of the shaft 10 (the wings are

retained in the recesses by the under-side of former projections 54.

Tilting of the anvil 24 is effected by the cam  
5 mechanism 22 via the anvil-support 30, which is  
slidable axially within the shaft 10A in channel 32.  
The front end of the anvil-support 30 is bifurcated to  
form two arms 34 having lateral projections 36. These  
projections slide in rebates 38 in the right hand side  
10 shaft 10A. The anvil-support 30 is movable, by the cam  
mechanism 22, from a forward position, Fig. 7, wherein  
the arms 34 extend under the fingers 24A and support  
them directly in front of a surgical staple 40 to be  
delivered, and a rearward position, Fig. 10, wherein  
15 the arms 34 are withdrawn under the downwardly inclined  
tilt arms 24B at the rear of the anvil 24 so as to tilt  
the anvil anti-clockwise (as seen in Fig. 10) and  
displace the fingers 24A out of the path of the staple  
40.

20

Referring additionally to Figs. 11, 11A and 11B, a  
hollow blood locator tube 92 is slidable axially within  
the shaft 10 in a channel 44 in the anvil-support 30.  
The tube 92 extends the full length of the shaft 10 and  
25 has a constant, generally oval cross-section, except at  
its ends. At the tip of the locator tube 92 it tapers,  
95, to a narrow opening 96 whose width is less than the  
nominal width of the tube; and at the rear 94 the tube

92 is crimped to only allow the guidewire 18 and not blood to exit the rear of the locator tube.

Under the action of the cam mechanism 22 the tube 92 is  
5 slidable axially in the shaft 10 between a forward  
position, Figs. 6 and 7, wherein its front end projects  
beyond the bullet portion 14 of the shaft 10, and a  
rearward position, Figs. 9 and 10, wherein the front  
end of the tube 92 is retracted within the bullet  
10 portion 14 behind the fingers 24A of the anvil 24.

The purpose of the blood locator tube 92 is to follow a  
previously placed guidewire 18 to a puncture site in a  
blood vessel, thereby to locate the free end of bullet  
15 portion 14 of the shaft 10 against the exterior wall of  
the blood vessel at the puncture site. To properly  
locate the bullet portion 14 the front end of the tube  
92 must actually penetrate the blood vessel through the  
puncture site and this is indicated by blood flowing  
20 back through the tube 92 and out through a blood outlet  
port 93 (Fig. 4) in the tube. A channel (not shown) in  
the part of the left hand side shaft 10B within the  
housing 12 communicates the port 93 with a blood exit  
port 50 (Fig. 1) on the side of the housing 12B, so  
25 that the blood flowing back through the tube 92 is  
visible at the exterior of the housing.

It has been found that the naturally formed shape of  
puncture wounds in arterial walls is elongated rather

than round. Whereas the hole is formed by introducing instruments generally of round cross section, the wall tends to open generally along a transverse line which lies in the direction of the circumference of the  
5 artery (rather than along the axis of the artery). By having a generally oval blood locator tube, the locator tube (when introduced by the clinician with the major axis of the oval perpendicular to the axis of the artery), will fit more naturally within the arterial  
10 opening. The consequence of this is that the wound edges which are to be stapled together, lie closer together than if a tube of circular cross section were to be used.

15 This in turn has the consequence that the staple used need not be so large, and in turn, the dimensions of the shaft, which must accommodate the staple when in its unformed state, can be reduced, leading to less trauma for the tissue into and from which the shaft is  
20 introduced.

A further consequence of having a generally oval or elongated cross section for the locator tube is that the tube will be more disposed to the centre of the  
25 puncture than with a rounded tube. The invention has a staple which straddles the locator tube, thereby increasing the likelihood of the staple closing the elongated wound at its centre rather than towards one or other of the extremities of the wound.

The aperture 96 at the front of the tube has a roughly circular portion 96A which is of greater diameter than the width of the remainder of the aperture 96. The  
5 guidewire 18, which passes through the tube 92, Fig. 11, is chosen to be of sufficiently smaller diameter than the diameter of the opening 96A at the front end of the tube 92 for the guidewire 18 to be easily inserted into the tube 92. However, the guidewire is  
10 also chosen to be too large to fit within the remainder of opening 96. In this way guidewire 18 is constrained to remain in opening 96A, and the size of opening 96A sets an upper limit on the diameter of guidewire which can be used with the device. One could introduce a  
15 narrow neck into the opening 96 just above opening 96A (at the point indicated by 96b) to ensure that very small guidewires were constrained within the enlarged opening 96A, but in general this is unnecessary, as the guidewire will be supplied with the device, or the  
20 device will only be sold for use with a particular gauge of guidewire.

The rear crimp 94 and tip opening 96A are positioned to encourage the guidewire to lie along the bottom curved  
25 surface of the tube, i.e. that portion of the tube lying in a direct line between the opening in the crimped end and the opening 96A. This helps prevent guidewire 18 from laying up against the inside of blood

exit port 93 and preventing egress of blood, Fig. 11A and 11B.

The curvilinear nature of opening 96 increases the  
5 available inlet area to match that of the available area within the body of the locator tube with the guidewire 18 in situ.

Opening 96 slopes away from opening 96A for ease of  
10 insertion into the vessel opening and to reduce the potential of trauma to the inner wall of the vessel opposite the opening being stapled. This is achieved because the guidewire 18 protruding from opening 96A will tend to push the opposite wall of the vessel away  
15 from the locator tube tip, and the point at which the guidewire protrudes (due to it being constrained in the opening 96A) is the farthest part forward of the tip. Thus, the shape of the tip is streamlined away from opening 96A to prevent any part of the tip gouging into  
20 or otherwise damaging the inner vessel walls.

An alternative embodiment of a locator tube distal end is shown in Figs. 12 and 13, The guidewire 18, which passes through the tube 42, is usually chosen to be of  
25 sufficiently smaller diameter than the diameter of the opening 46 at the front end of the tube 42 for there to be an adequate gap for the blood to pass back through the tube 42 even in the presence of the guidewire. However, as is best seen in Figs. 12 and 13, further



openings 46A are provided in opposite sides of the tube 42 just behind the front opening 46 to allow more ready access of the blood to the interior of the tube in cases where the guidewire 18 may not leave a large enough gap for passage of blood solely through the opening 46. The openings 46, 46A in fact form part of a single opening, being in reality three connected lobes, all connected by constricted channels 47, and all in communication with the interior of the tube.

10

A problem can arise in devices of this type where an oversized guidewire is used which occludes the hollow interior of the blood locator tube and thereby prevents blood flow back through the tube. To prevent this situation the lobe 46 through which the guidewire emerges in the tip of the tube of Figs. 12 and 13 is of a lesser diameter than the internal bore of the tube. The dimensions of this lobe 46 set a maximum for the guidewire diameter for use with the device, and ensure that even when this maximum diameter guidewire is used, there is still sufficient internal clearance within the tube bore to allow a strong blood flow through the tube from the other lobes 46A.

25 The staple 40 straddles the blood locator tube 92 within the bullet portion 14 of the shaft 10, see Figs. 6 and 8, and is slidable thereon forwardly towards the free end of the bullet portion 14. In particular (see also the enlarged view of Fig. 14), the staple 40

comprises a back or base portion 40A from which extend perpendicularly at each end respective legs 40B which terminate in sharpened points. The base portion 40A and legs 40B lie in substantially a common plane except  
5 for a centre portion 40C of the base portion 40A which is deformed in a direction perpendicular to the legs 40B so as to have a U-shape complementary to the external cross-sectional profile of the blood locator tube 92. The staple 40 is mounted on the blood locator  
10 tube 92 such that the centre portion 40C of the staple sits on the upper half of the tube 92, as seen in Fig. 6 and 8, with the legs 40B pointing forwardly on opposite sides of the tube 92. The depth of the centre portion 40C of the staple 40 is such that the legs 40B  
15 of the staple lie substantially directly on opposite sides of the central axis of the tube 92. This will ensure that the staple 40 is positioned centrally across the puncture hole in the blood vessel. In order to avoid the guidewire 18 fouling the staple 40 when  
20 the latter is closed on the puncture site, the hole 96A is offset below the plane containing the legs 40B of the staple, Fig. 10.

The staple delivery mechanism further includes an  
25 elongated former 52 having a cross-section conforming to that of the blood locator tube 92 and slidable on the blood locator tube 92 axially within the shaft 10. The former 52 is located behind the staple 40 on the tube 92 and is operated by the cam mechanism 22. At

its front end the former 52 has a pair of forming arms 54 which are so shaped that, when the former 52 is driven forward by the cam mechanism 22, the staple 40 is driven against and deformed around the anvil fingers 24A so that the legs 40B of the staple close together (Fig. 9) onto the puncture site. During such movement the staple legs slide toward the anvil 24 in moulded tracks 16 within the bullet portion 14. These tracks provide a slight interference fit on the staple legs 40B to prevent the staple 40 moving forward prior to firing and during storage of the device.

The cam mechanism 22 can be seen in Fig. 3 and in enlarged views of Figs. 15 and 16. The mechanism 22 consists of a first cam 58 and a second cam 60 mounted on a common axis 62 which sits in a recess 64 in the left-hand side 10A of the shaft (Fig. 4) and a corresponding recess (not shown) in the right-hand side 10B. Trigger 56 is similarly mounted in the shaft by a pair of pegs 66 which are received in a trigger seating recess 68 in each half of the shaft 10, Fig. 4.

An actuating pin 70 extends through the first and second cams 58, 60. This actuating pin is acted on by a cam actuating surface 72 (see also Fig. 3) provided on the trigger 56, so that when the trigger is squeezed the actuating surface moves the actuating pin in an anticlockwise direction around the axis 62. Because the actuating pin extends through both cams 58, 60 of

the mechanism 22, the cams are both rotated simultaneously through the same angle as determined by the trigger squeeze. The geometry of the trigger pivot pins 66 and actuating surface 72 relative to the cam pivot 62 and cam actuating pin 70 is configured to minimise the trigger rotation to only 23 degrees whilst the cam rotates a total of 90 degrees. This configuration also provides a mechanical advantage that the trigger delivers to the cam actuating pin 70 of approximately 1:4. Trigger 56 further comprises a ratchet lever, shown in Fig. 3, which engages with ratchet strip, which is mounted in the right handle 12A, Fig. 3. This non-return ratchet system ensures the firing cycle of the staple is uninterrupted, non-repeatable and provides a positive indication that the device has been used. A cycle complete indicator, attached to the rear end of the anvil-support 30, further provides a visual indication, Fig. 1, to the operator that the firing cycle is complete.

20

Referring back to Fig. 4, a blood locator tube cam follower 74 is shown adjacent the blood locator tube 92 (to which it is attached when assembled). This blood locator tube cam follower 74 is acted on by the first cam 58. Similarly, the first cam 58 acts on a former cam follower 76, whereas the second cam 60 acts on anvil-support cam followers 78A and 78B.

25

The shape of the first and second cams 58, 60, is shown in elevation in Fig. 16 (the second cam 60 is shown in dotted outline as it is concealed by the first cam). Fig. 16 also shows actuating pin 70, and a reinforcing strut 80 mounted between the first and second cams  
5 diametrically opposite the actuating pin 70.

The cams are shown in the starting positions in Fig. 15 and 16. Squeezing the trigger fully (through an angle  
10 of 24 degrees) causes the cams to rotate anticlockwise through 90 degrees.

The blood locator tube cam follower 74 acts against the rear surface 82 of the first cam 58. As the first cam  
15 rotates anticlockwise from the position shown in Fig. 15, the distance between the blood locator tube cam follower 74 and the axis 62 is increased. This causes the blood locator tube to be drawn backwards as the trigger is squeezed.

20

The former cam follower 76 acts against the front surface 84 of the first cam 58. Again the distance between former cam follower 76 and axis 62 increases through the initial stages of the trigger being  
25 squeezed. However, a V-shaped section 84A of front section 84 causes the former 52 to be momentarily driven backwards by a former return spring 86 when the staple has been fully formed. The effect of this is to momentarily release the pressure of the formed staple

against the anvil, allowing the anvil to be dropped and the staple released from the device.

It can be seen that a raised hump 82A on the profile of the rear surface 82 of the first cam is located almost diametrically opposite the V-shaped section 84A. The reason for this is to increase the rate at which the blood locator tube is drawn out of the puncture site just before the staple is fully formed and released. The intention is to leave the tube in the puncture as late as possible to provide support for the walls of the blood vessel for as long as possible. The blood locator tube 92 is biased forward by a blood locator tube compression spring 88 which maintains pressure between blood locator tube cam follower 74 and the rear surface 82 of the first cam 58.

The blood locator tube compression spring 88 allows the locator tube to be displaced in a proximal direction (back into the shaft of the device) against the spring tension during insertion if the locator tube meets any significant resistance, to prevent unnecessary trauma to soft tissues, the vessel or its rear wall in the event of an excessive insertion force. An example of where this is particularly useful is if the stapler is advanced too far into the vessel, so that the tip of the tube 92 meets the inner wall. The blood locator tube will then be displaced back into the shaft, and may be designed to protrude through the end of the handle

housing to give a visual indication that the device has been inserted against the wall. Furthermore, the device may be designed so that the blood outlet port 93 on the tube 92 is brought out of registry with the blood exit port 50 in the handle housing when the tube is displaced backwards, so that the clinician will note the flow of blood ceasing when the tube meets the inner vessel wall in this way.

10 The cam mechanism 22, however, provides positive mechanical displacements for withdrawing the locator tube at the appropriate timing, to ensure there is no chance of the staple being formed whilst the locator tube is in a forward position and potentially  
15 interfering with the staple formation.

A further reason to leave the blood locator tube in the puncture hole as late as possible is that the continued retraction of the tube everts or turns outwards the  
20 opposed edges of the puncture wound and aids penetration of the staple legs into the arterial wall. Eversion of the edges of the puncture helps prevent thrombus formation within the vessel. When the locator tube is fully retracted, only the guidewire is left  
25 within the wound, and this will be easily retracted from the closed wound after the stapler has been removed from the puncture site.

The anvil-support cam follower 78B acts against the rear surface 90 of the second cam 60. It can be seen that this rear surface 90 provides the greatest increase in distance relative to the axis in the section 90A from about 60 to 90 degrees below the horizontal. The reason for this is that the anvil is maintained in place until the staple has been formed and the pressure on the former has been relaxed slightly to allow the anvil to drop. The anvil is maintained in place for the initial 60 degrees of rotation by the anvil-support cam follower 78A being in contact with cam surface 98 of cam 60, preventing the anvil-support 30 from moving from its starting position. The cam surface 98 for the first 60 degrees of cam rotation is at a constant distance from the cam axle 62 (in dwell).

In use, the stapler is initially in the "pre-fire" configuration shown in Figs. 6 to 8. The front end of the blood locator tube 92 is in a fully forward position projecting beyond the free end of the bullet portion 14 of the shaft 10, the anvil-support 30 is in a fully forward position with its arms 34 extending under the anvil fingers 24A and supporting them directly in front of the staple 40, the former 52 is in a fully retracted position away from the anvil fingers 24A, and the staple 40 is in its fully back position up against the forming arms 54.



In this configuration the external end of a previously positioned guidewire 18 is inserted into the hole 496A in the front end of the blood locator tube 92 and fed through the tube 92 until it exits a guidewire exit  
 5 port at the rear of the housing 12. The stapler is now fed along the guidewire 18 until the tip 95 of the tube 92 enters the blood vessel lumen through the puncture hole. This is indicated by blood flowing out of the blood exit port 50. At this point the front end of the  
 10 bullet portion 14 of the shaft 10 will be resting against the exterior wall of the blood vessel.

Now the trigger 56 is squeezed, causing the cams of the cam mechanism 22 to rotate through 90 degrees. As  
 15 mentioned, the rear end of each of the blood locator tube 92, anvil-support 30 and former 52 are coupled to the cam mechanism via cam followers and the following co-ordinated movement of these components takes place as the cams rotate through 90 degrees.

20

0 degrees: Stapler in pre-fire configuration as described above (Figs. 6 to 8).

25

30 degrees: Former 52 moved forward pushing staple 40 ahead of it; blood locator tube 92 retracting.

40 degrees: Former 52 and staple 40 further forward; blood locator tube 92 further retracted.

- 50 degrees: Former 52 forward sufficiently to clamp  
staple 40 against anvil fingers 24A;  
blood locator tube 92 further retracted.  
5 At this point the staple legs 40B will  
have punctured wall of blood vessel but  
staple not yet fully deformed.
- 58 degrees: Former 52 forward sufficiently to deform  
10 the staple legs 40B around the anvil  
fingers 24A and close the staple on  
puncture site (Figs. 9 and 10); blood  
locator tube 92 fully retracted. At  
15 some point between 50 and 58 degrees the  
blood locator tube 92 will have  
withdrawn from between the staple legs  
40B in time to allow them to close.  
This should be left as late as possible  
to provide support for the walls of the  
20 blood vessel for as long as possible.
- 65 degrees: Former 52 retracted slightly to release  
clamp force on staple 40. Anvil-  
support 30 starting to retract.  
25
- 77 degrees: Anvil-support 30 retracted to clear  
anvil fingers 24A.

90 degrees: Anvil-support 30 fully retracted under tilt arms 24B; anvil fingers 24A dropped down to release staple.

- 5 The use of cams in cam mechanism 22 ensures the accuracy of sequence and relative timing between events as well as ensuring positive mechanical displacements of all components.
- 10 In a further embodiment the trigger activates an automatic firing cycle, not shown. A tension spring attached to the cams is released from its extended state so as to rotate the actuation cam through a 90 degree arc causing the same component movements as
- 15 described above.

In an alternative embodiment, not shown, as the forward end of the former 52 retracts it engages pull arms on the anvil-support 30 causing it to move in a rearward

20 direction. As it does so, it engages with the rear end of the anvil 24, which is angled downward into the path of the moving slide. Centrally opposed wings extend from the anvil and are located so as to pivot in opposed wing slots formed in the right hand side 10A of

25 the shaft. Once engaged with the slide the rear end of the anvil is pushed upward causing it to pivot about the wings and arc the forward end of the anvil downward. As it does so, it disengages from the staple

so that the device can be removed form the puncture tract along the guidewire.

In a further embodiment the reverse profile 82 on the first cam 58 which engages with the cam follower 74 on the blood locator tube 92 is extended so that when the staple forming cycle is completed the first cam continues to rotate causing the blood locator tube to move further in a proximal direction. At its distal end the blood locator tube has wings which as it moves in a proximal direction engages with the pull arms of the anvil-support 30 causing it to move in a proximal direction and engage the anvil tilt arms thereby disengaging the distal end of the anvil from the formed staple. In this embodiment the second cam is redundant and can be omitted.

The invention is not limited to the embodiments described herein and may be modified or varied without departing from the scope of the invention.

## CLAIMS

1. A surgical stapler comprising a shaft, a locator  
slidable axially of the shaft between a forward  
5 position wherein the locator projects beyond a free end  
of the shaft to enter a puncture site in a liquid-  
carrying vessel in a human or animal, thereby to locate  
the free end of the shaft at the puncture site, and a  
rearward position wherein the locator is retracted  
10 relative to the shaft, a surgical staple straddling the  
locator and slidable forwardly thereon, said staple  
having forwardly pointing legs disposed respectively on  
opposite sides of the locator, an anvil against which  
the staple may be deformed to staple together opposite  
15 edges of the puncture site, and an actuator for driving  
the staple forwardly along the locator into deforming  
engagement with the anvil and for retracting the  
locator in co-ordination with the movement of the  
staple such that the locator means is withdrawn from  
20 between the legs of the staple in time to allow the  
legs of the staple to staple together opposite edges of  
the puncture site.

2. A surgical stapler as claimed in claim 1, wherein  
25 the actuator drives the staple via an elongated former  
slidable axially of the shaft.

3. A surgical stapler as claimed in claim 1 or 2,  
wherein the anvil is tiltable relative to the shaft

- axis between a first position wherein the anvil is in a position for engagement by the staple and a second position wherein the anvil is clear of the staple, the actuator further including a tilting mechanism for
- 5 tilting the anvil in co-ordination with the movement of the locator and staple such that the anvil is tilted from the first position to the second position after closure of the staple onto the puncture site.
- 10 4. A surgical stapler as claimed in claim 3, wherein the tilting mechanism for tilting the anvil comprises an elongated member slidable axially within the shaft.
5. A surgical stapler as claimed in any preceding
- 15 claim, wherein the locator has a generally oval cross-section.
6. A surgical stapler as claimed in any preceding claim, wherein the forward end of the locator is
- 20 tapered.
7. A surgical stapler as claimed in any preceding claim, wherein the legs of the staple lie substantially directly on opposite sides of a central axis of the
- 25 locator.
8. A surgical stapler as claimed in any preceding claim, wherein the locator comprises a hollow tube having an opening at the forward end to enable liquid

flow to be sensed within a liquid-carrying vessel to thereby locate the puncture site in the vessel.

9. A surgical stapler as claimed in claim 8, wherein  
5 a guidewire is carried within the locator tube and wherein said guidewire emerges from said tube at the opening.

10. A surgical stapler as claimed in claim 9, wherein  
10 the opening comprises a plurality of connected lobes each in communication with the hollow interior of the tube, the guidewire emerging through one of said lobes.

11. A surgical stapler as claimed in claim 10, wherein  
15 the lobe through which the guidewire emerges is dimensioned only to permit the passage of a guidewire having dimensions less than the internal dimensions of the hollow tube, whereby sufficient free space is provided between the internal surface of the tube and  
20 the outside of the guidewire to allow liquid to flow through the tube from the or each of the other lobes.

12. A surgical stapler according to claim 10 or 11,  
25 wherein the guidewire emerges from a lobe at the tip of the tube, and wherein the other lobes are disposed at the forward end of the tube adjacent the tip.

13. A surgical stapler as claimed in claim 9, wherein the opening at the forward end of the locator tube is disposed on the tube so as to cause the guidewire to emerge offset from between the legs of the staple.

5

14. A surgical stapler as claimed in any preceding claim, wherein a portion of the shaft has an increased diameter at its free end.

10 15. A surgical stapler as claimed in any preceding claim, wherein the shaft is attached to a handle and the actuator means comprises a cam mechanism mounted in the handle.

15 16. A surgical stapler as claimed in claim 15, when dependent on claim 2, wherein the cam mechanism comprises a cam which drives the former forward to deform the staple against the anvil, and which is shaped to relax the driving force once the staple has  
20 been formed to thereby enable the staple to be cleared from the anvil.

17. A surgical stapler as claimed in claim 15 or 16, wherein the cam mechanism is trigger operated.

25

DATED THIS 18th DAY OF JANUARY 2001



SPOOR AND FISHER  
APPLICANTS PATENT ATTORNEYS



*Morris*

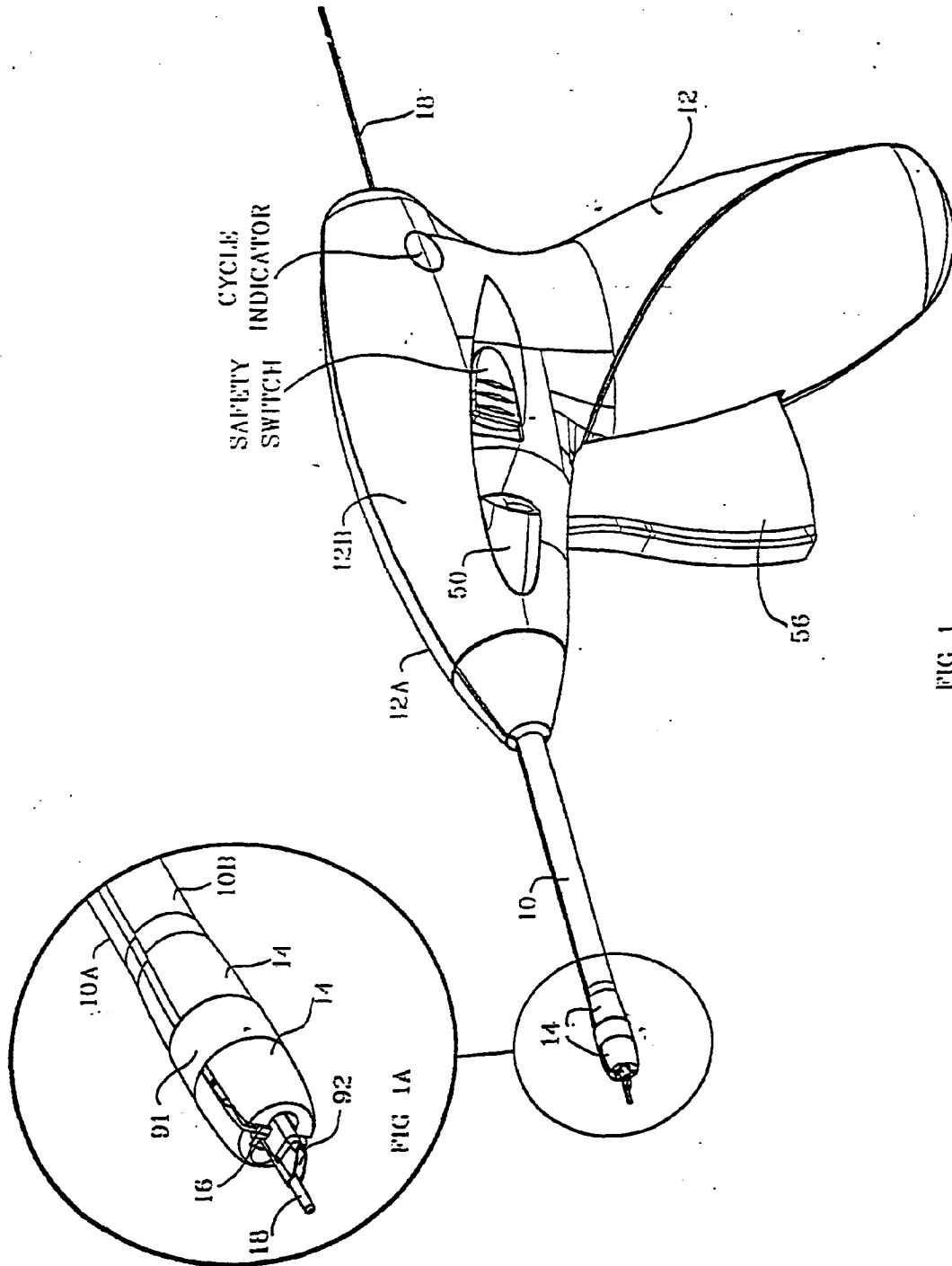

FIG 1

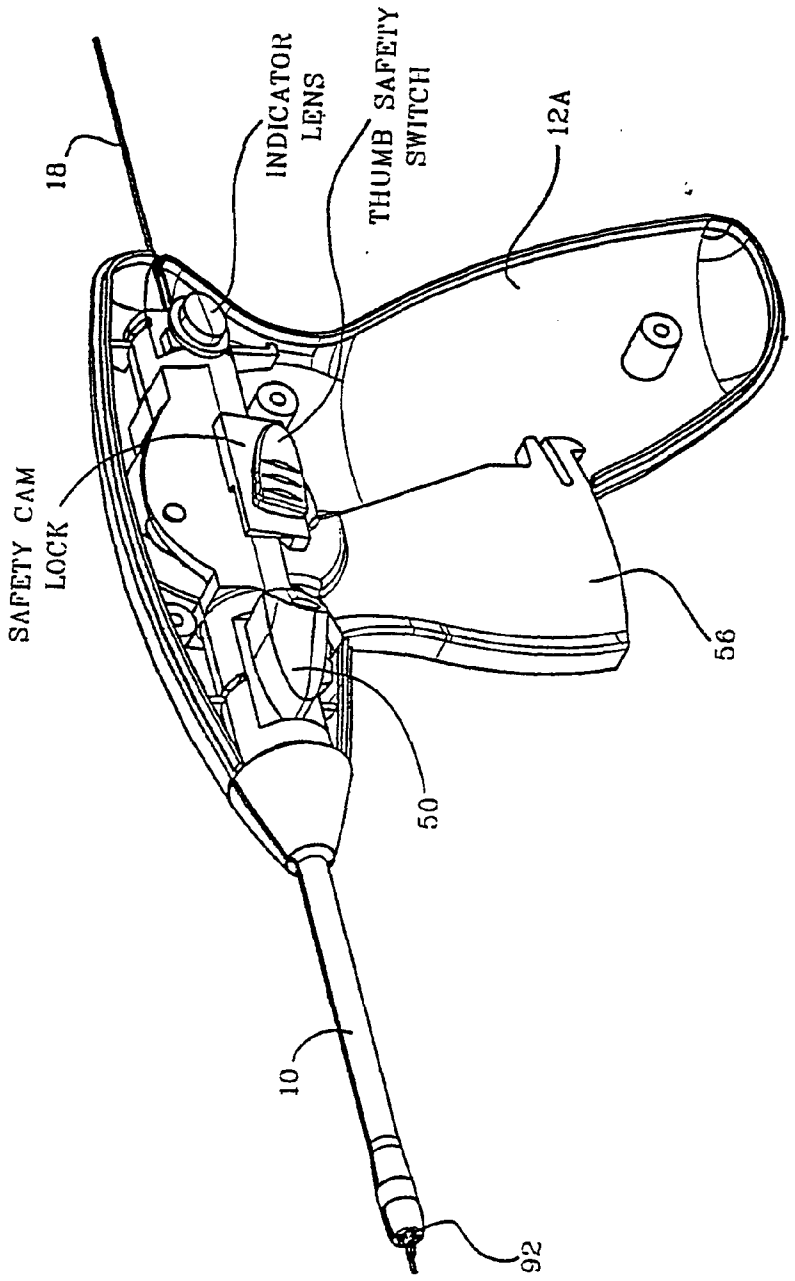

FIG 2

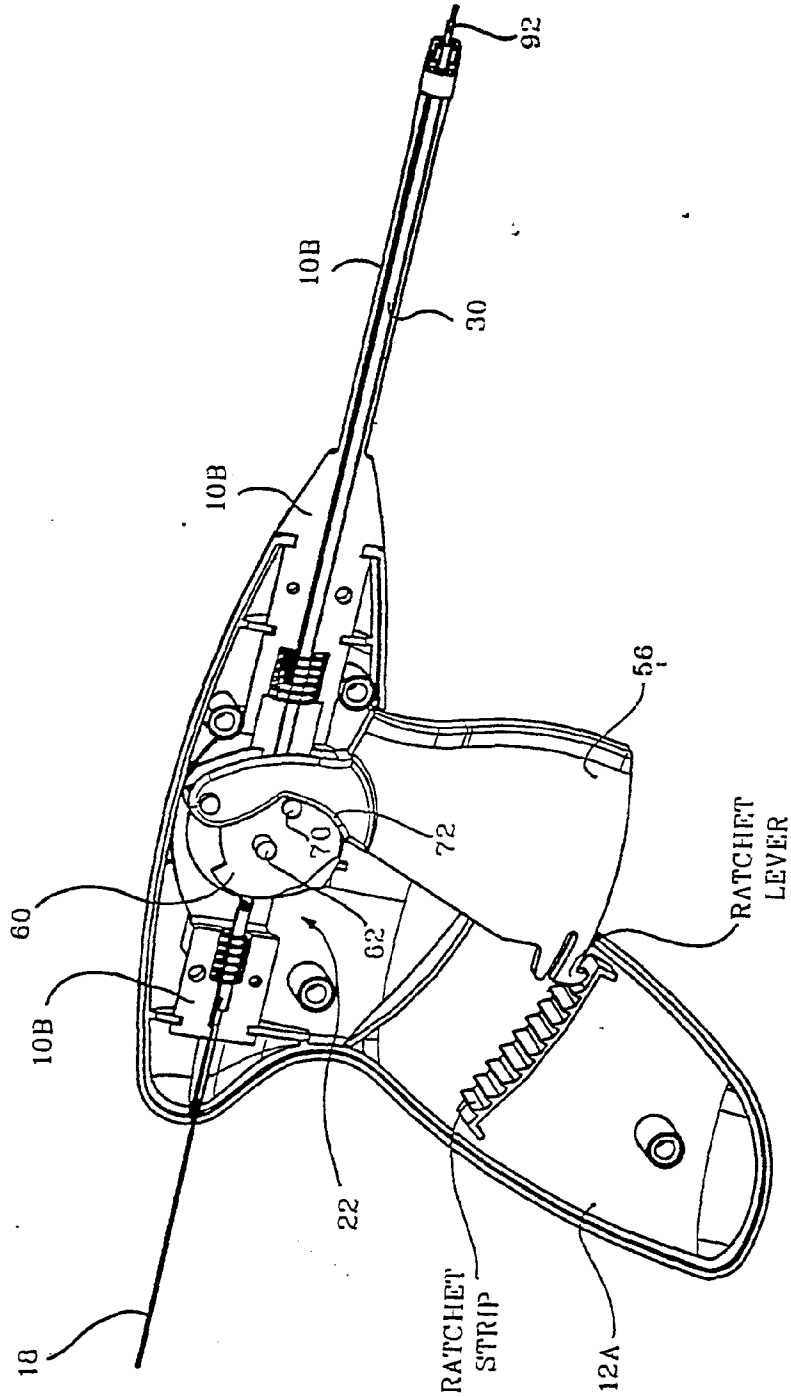

FIG 3

*Morris*

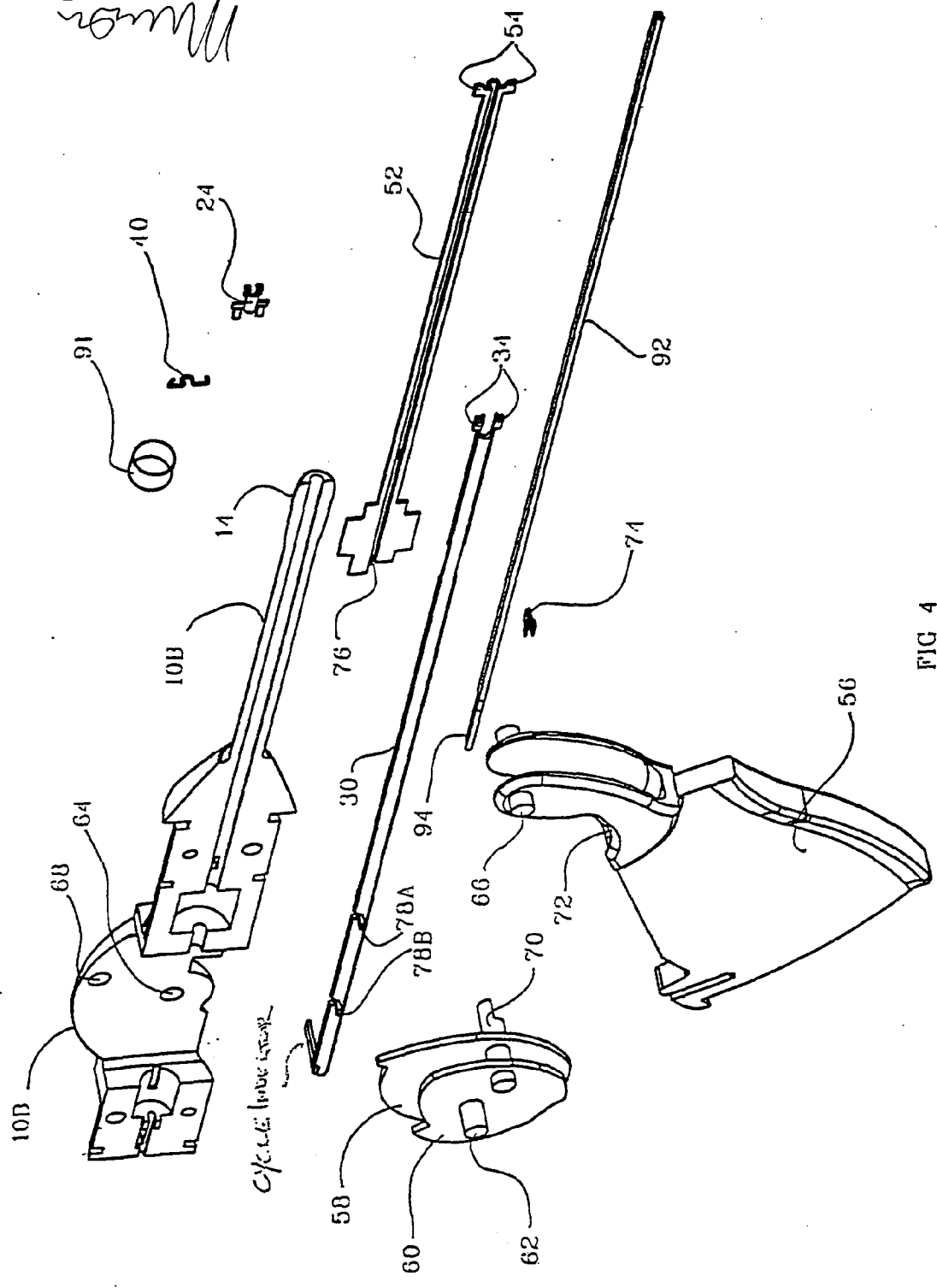
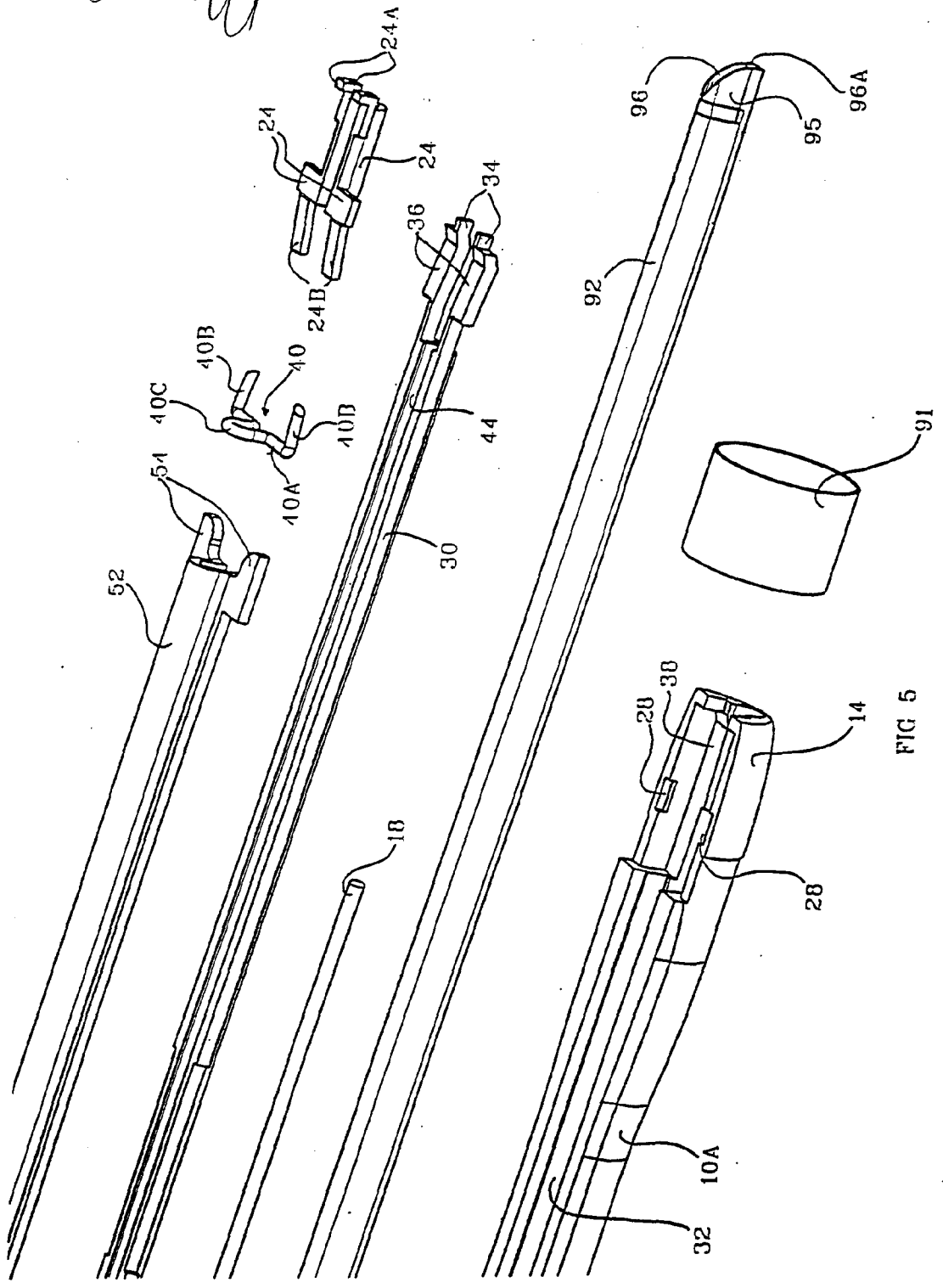

FIG 4



SPOR AND FISHER  
APPLICANTS PATENT ATTORNEYS

*Morris*

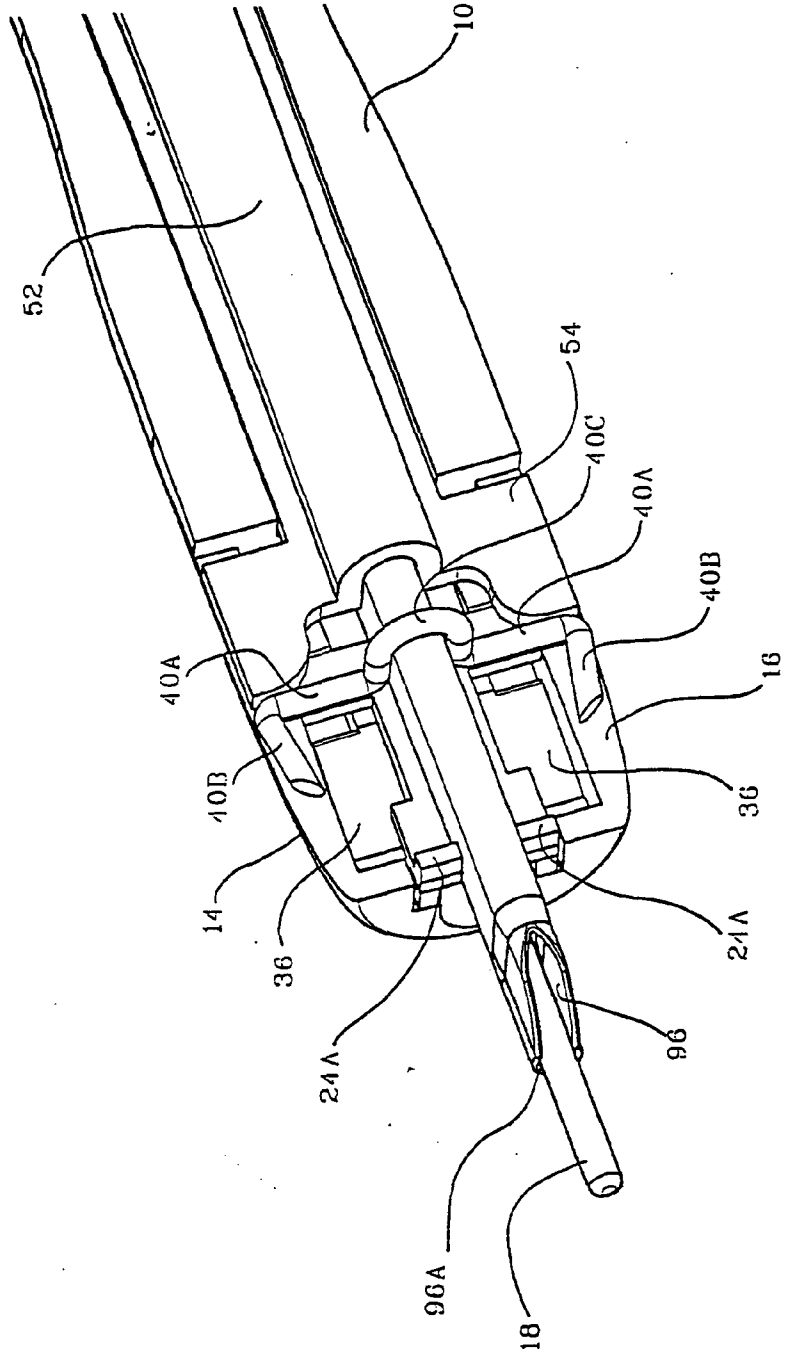

FIG 6

*Morris*

*Morris*

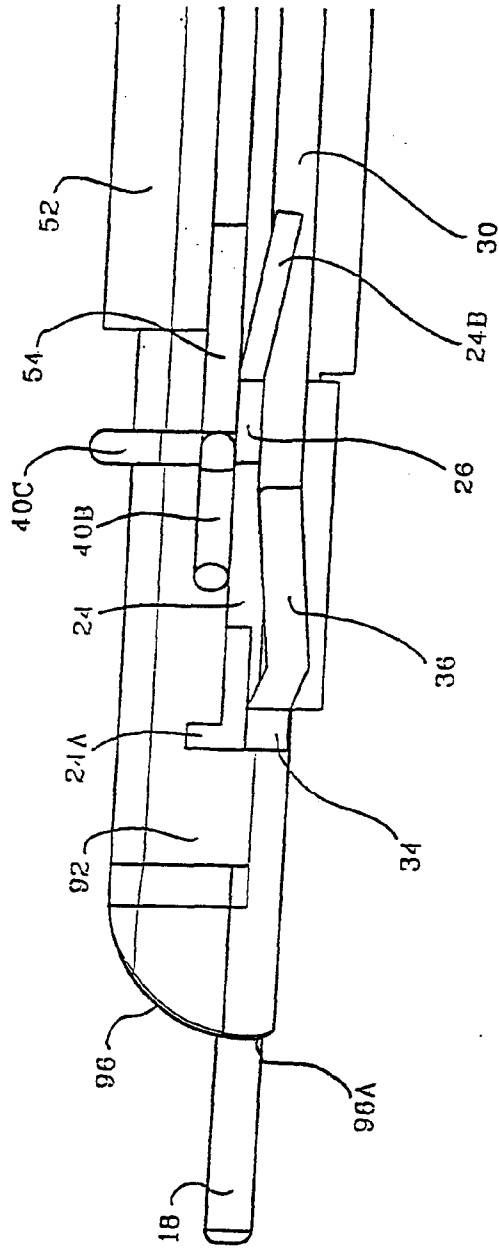
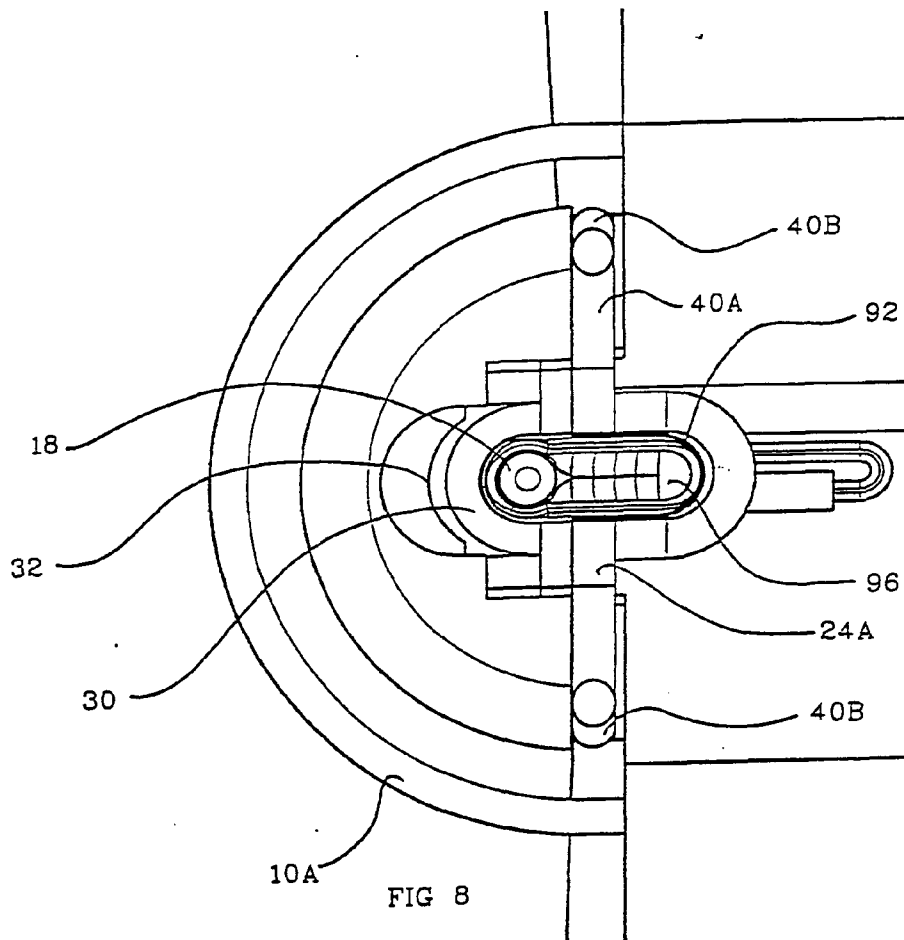

FIG 7



*Muon*  
SPOOR AND FISHER  
APPLICANTS PATENT ATTORNEYS



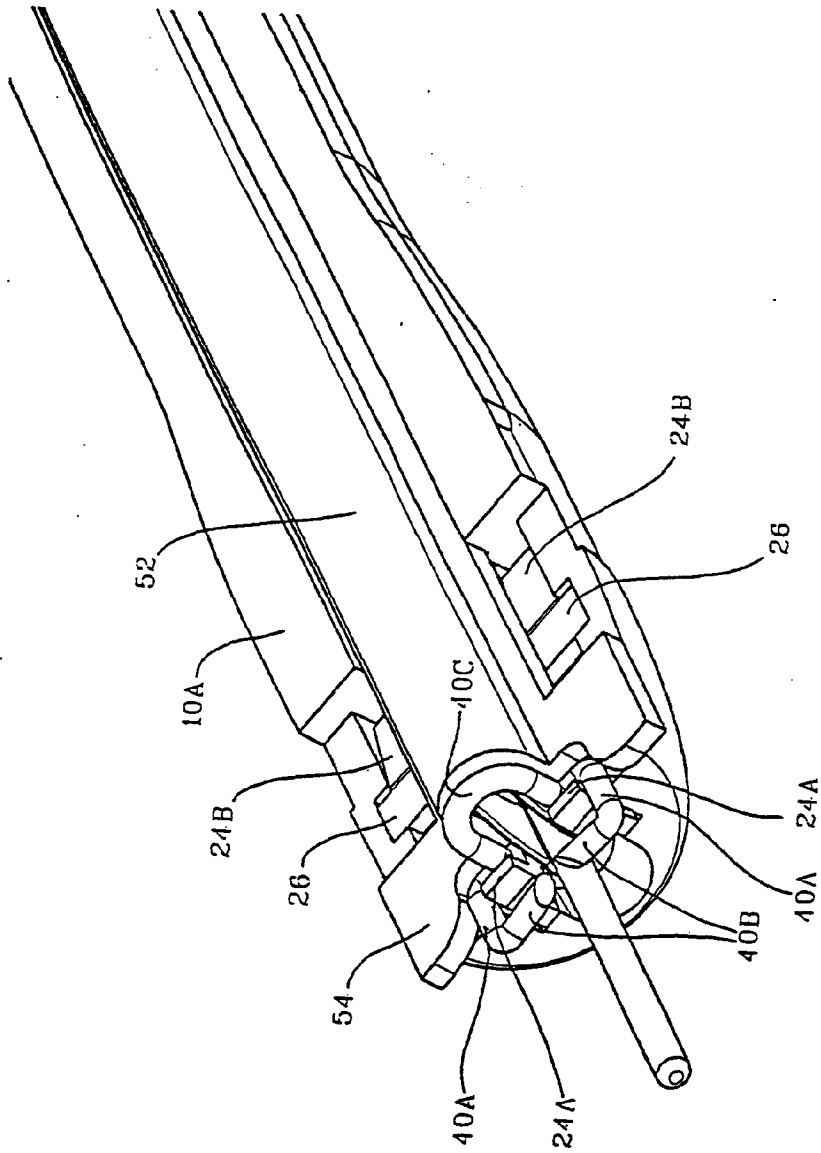

FIG 9

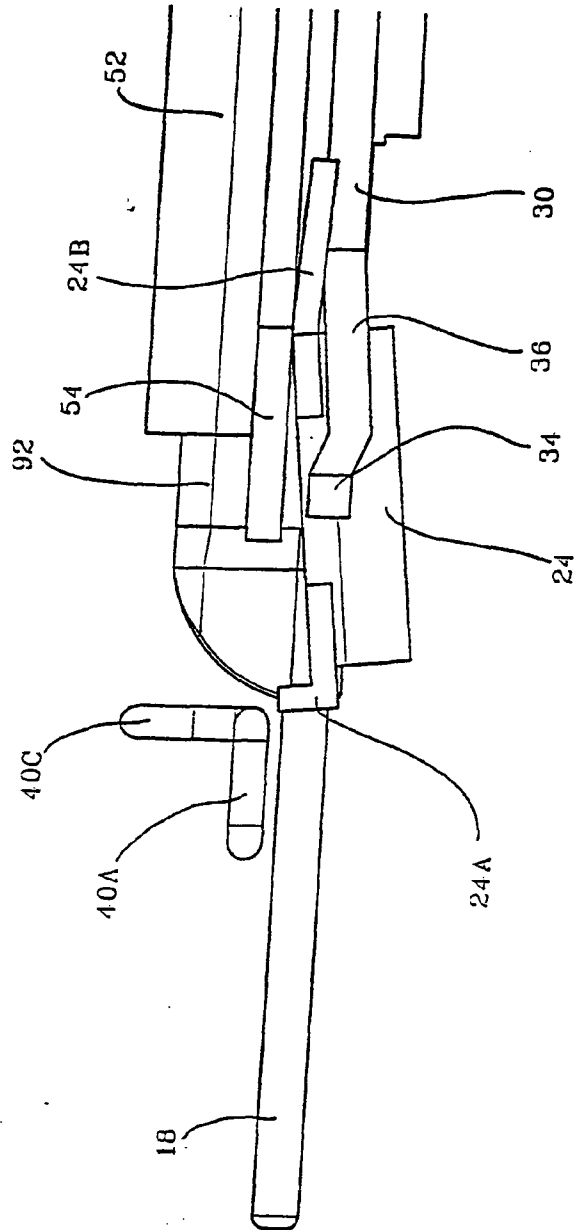
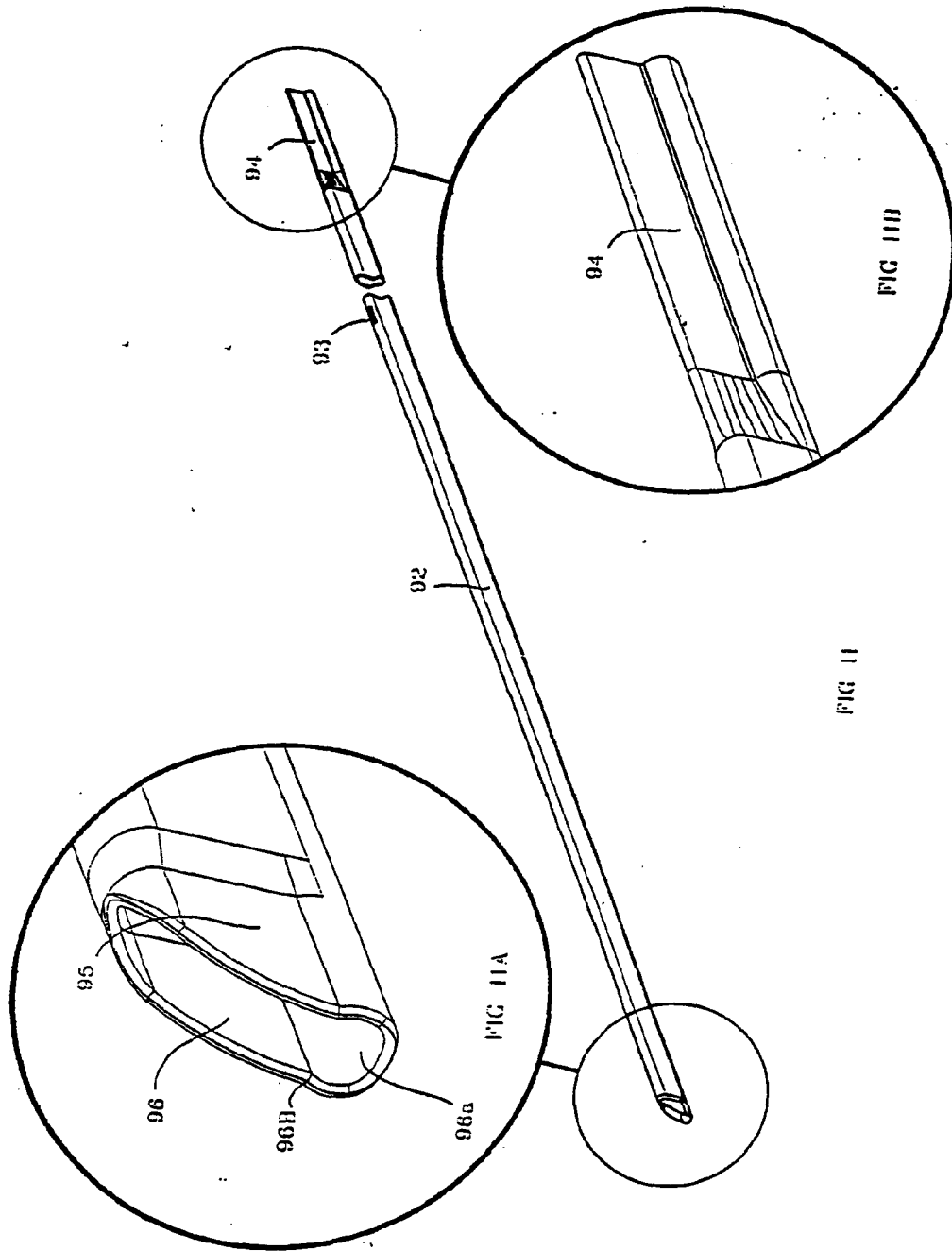

FIG 10

*Morris*  
SPOOR AND FISHER  
APPLICANTS PATENT ATTORNEYS



*Murphy*

SPOOR AND FISHER  
APPLICANTS PATENT ATTORNEYS

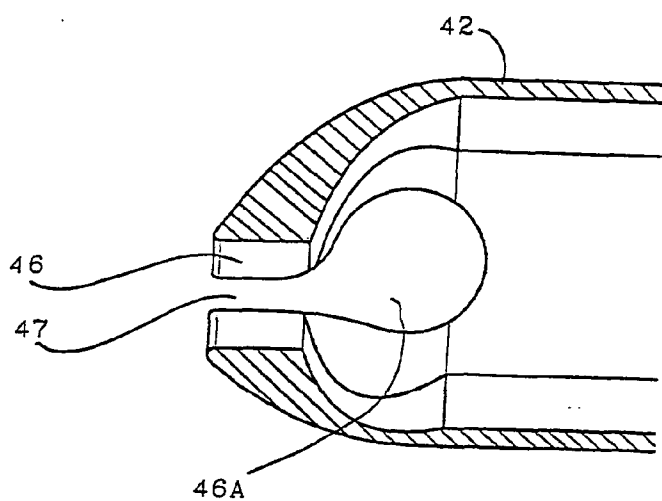

FIG 12

*Munson*  
SPOOR AND FISHER  
APPLICANTS PATENT ATTORNEYS

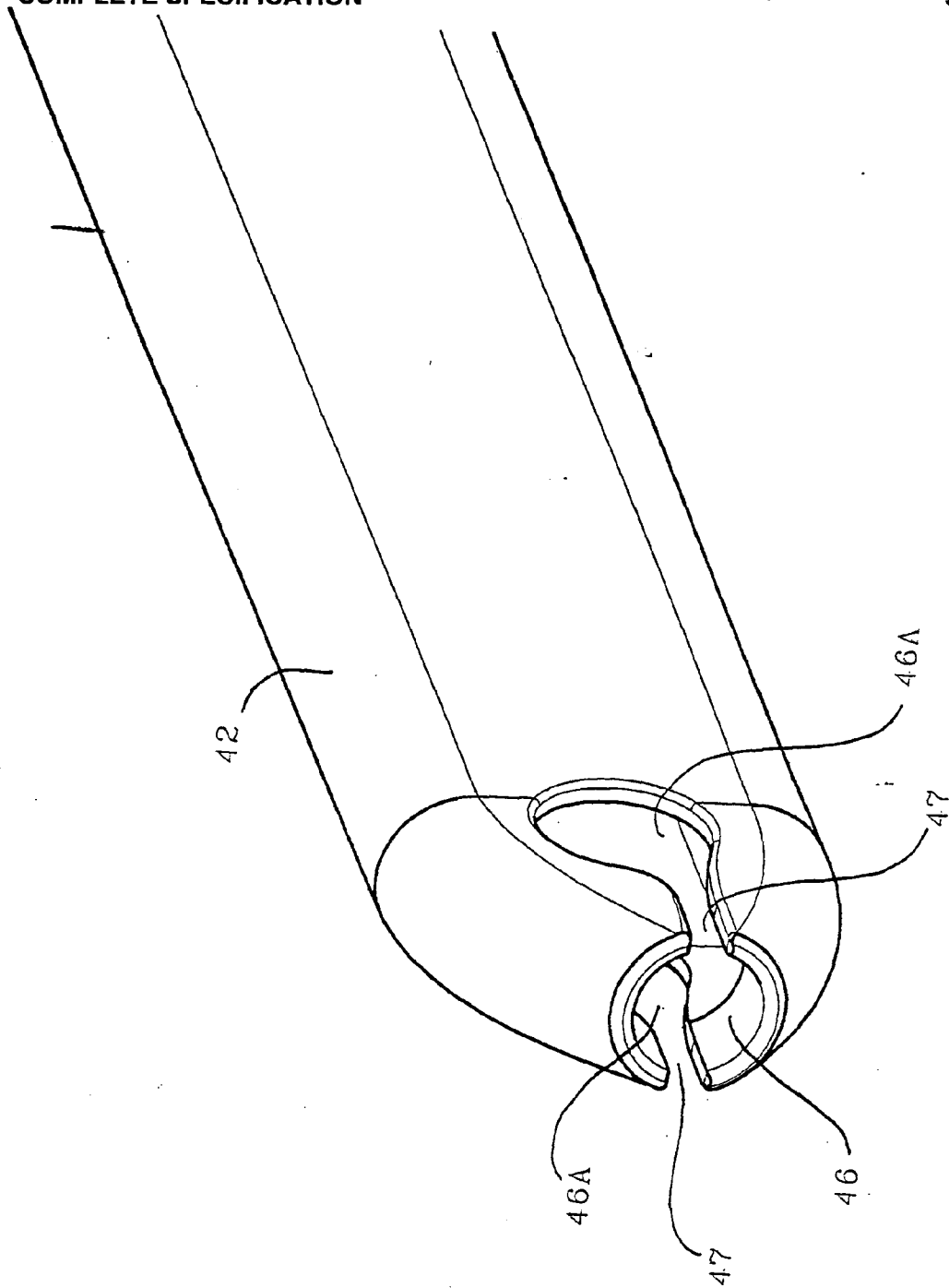

FIG 13

*Muon*

SPOOR AND FISHER  
APPLICANTS PATENT ATTORNEYS

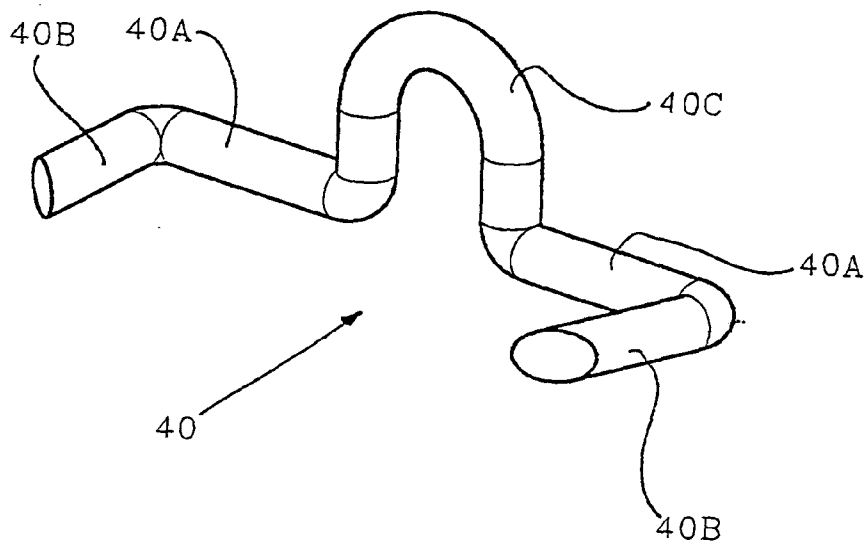
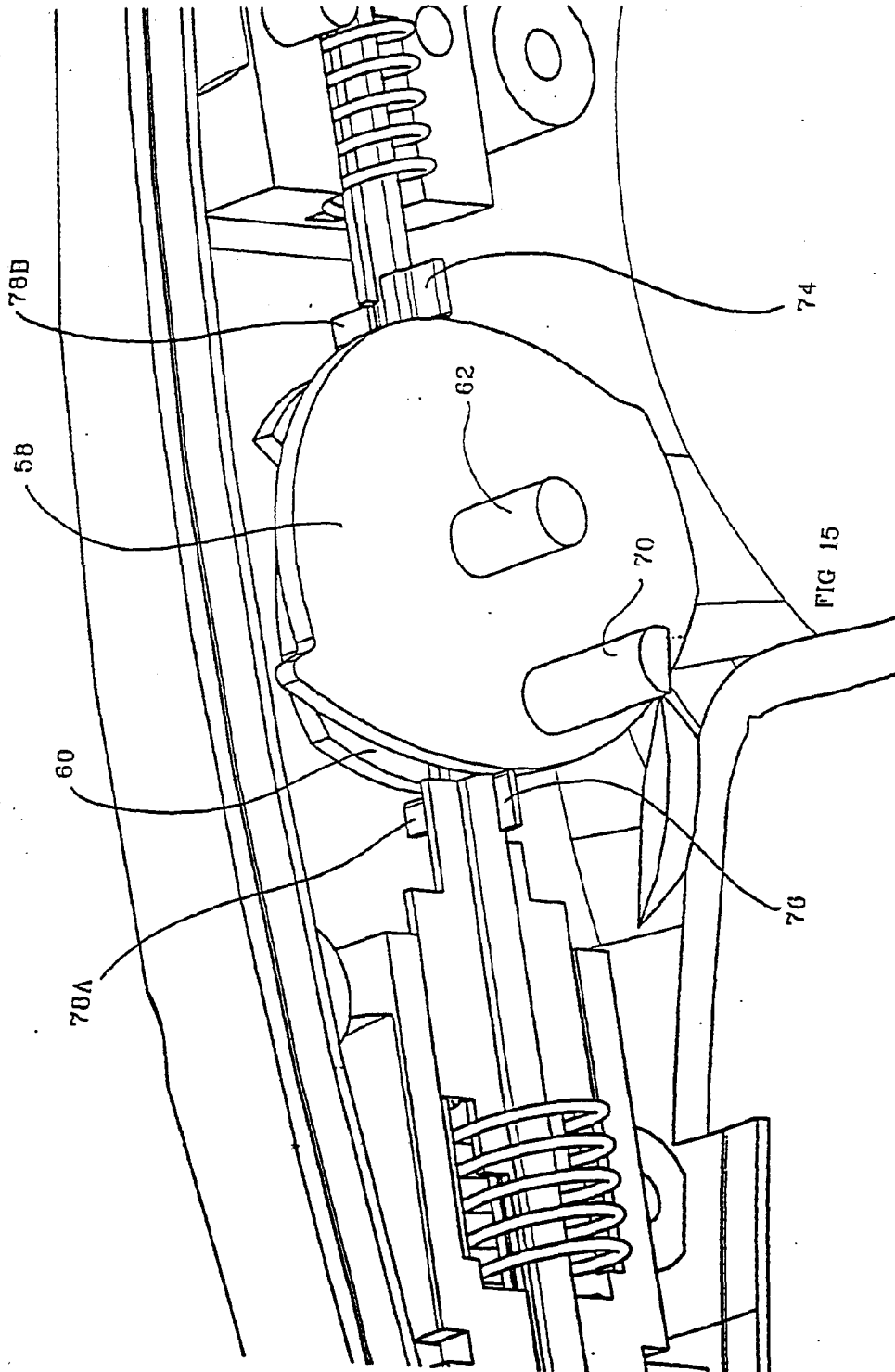

FIG 14

*Morris*  
SPOOR AND FISHER  
APPLICANTS PATENT ATTORNEYS



*Mason*  
SPOOR AND FISHER  
APPLICANTS PATENT ATTORNEYS

20010527

COLEMAN JAMES E; CUMMINS CHRISTY; MARTIN CHRIS; ANTHONY THOMAS AND  
MORRIS SEAN  
COMPLETE SPECIFICATION

16 SHEETS  
SHEET 16

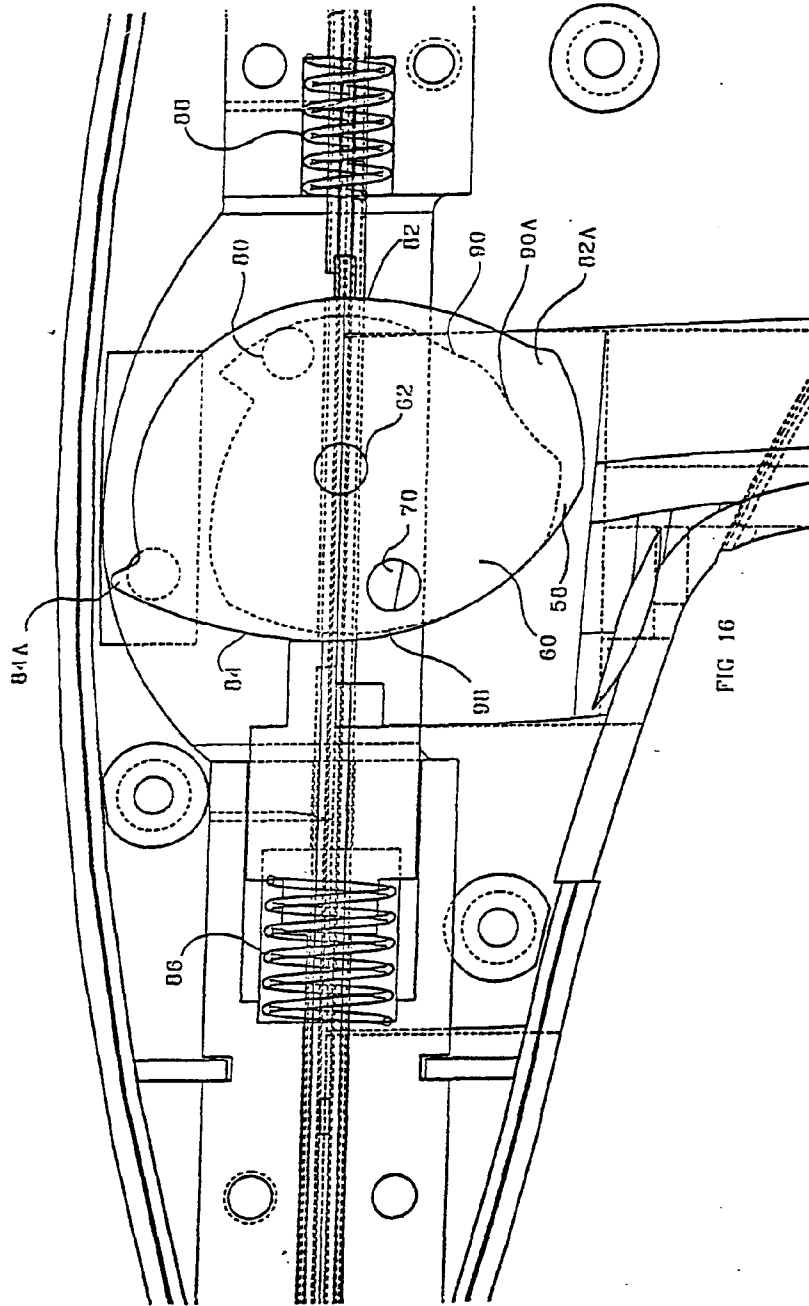

*Morris*  
SPOOR AND FISHER  
APPLICANTS PATENT ATTORNEYS