



US 20040170403A1

(19) **United States**

(12) **Patent Application Publication**
Lei

(10) **Pub. No.: US 2004/0170403 A1**

(43) **Pub. Date: Sep. 2, 2004**

(54) **APPARATUS AND METHOD FOR
VAPORIZING SOLID PRECURSOR FOR CVD
OR ATOMIC LAYER DEPOSITION**

Publication Classification

(51) **Int. Cl.⁷ C23C 14/26**

(52) **U.S. Cl. 392/388**

(75) **Inventor: Lawrence C. Lei, Milpitas, CA (US)**

Correspondence Address:
Patent Counsel
APPLIED MATERIALS, INC.
P.O. Box 450-A
Santa Clara, CA 95052 (US)

(57) **ABSTRACT**

An apparatus and method for effectively and controllably vaporizing a solid precursor material is provided. In particular, the present invention provides an apparatus that includes a housing defining a sealed interior volume having an inlet for receiving a carrier gas, at least one surface within the housing for the application of a solid precursor, and a heating member for heating the solid precursor. The heating member can be located in the housing or in the surface within the housing. The surface can be a rod, baffle, mesh, or grating, and is preferably s-shaped or cone-shaped. Optionally, an outlet connects the housing to a reaction chamber. A method for vaporizing a solid precursor using the apparatus of the present invention is also provided.

(73) **Assignee: Applied Materials, Inc.**

(21) **Appl. No.: 10/792,323**

(22) **Filed: Mar. 3, 2004**

Related U.S. Application Data

(63) **Continuation of application No. 09/953,451, filed on
Sep. 14, 2001, now Pat. No. 6,718,126.**

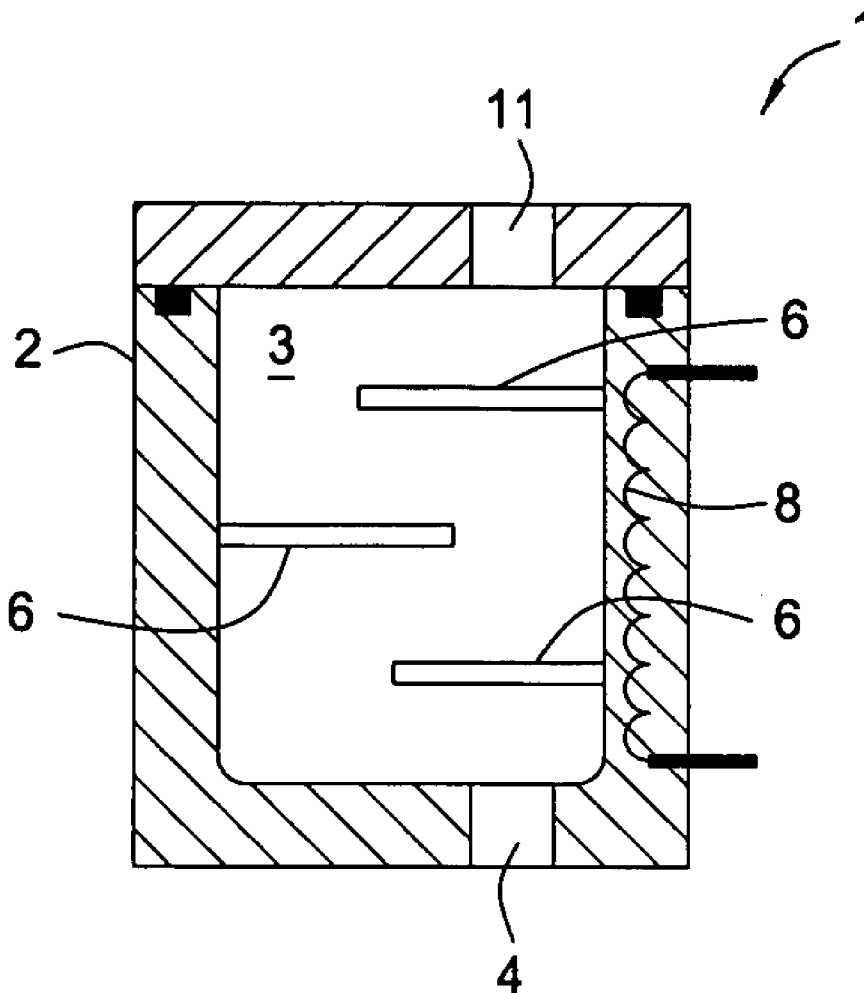

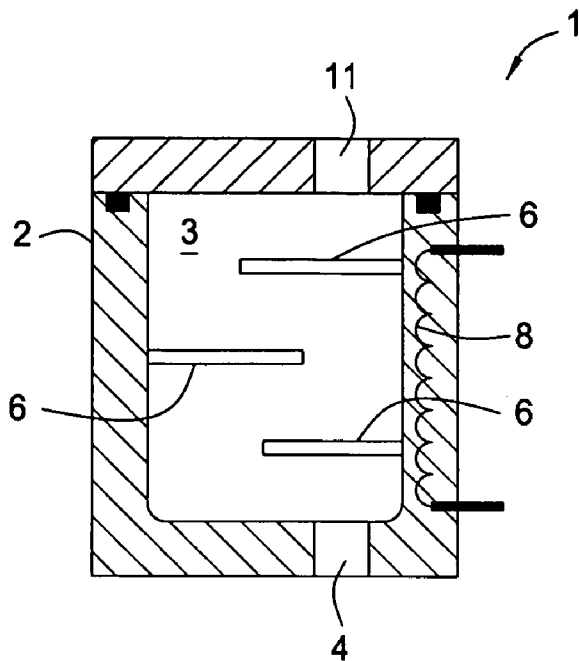

FIG. 1

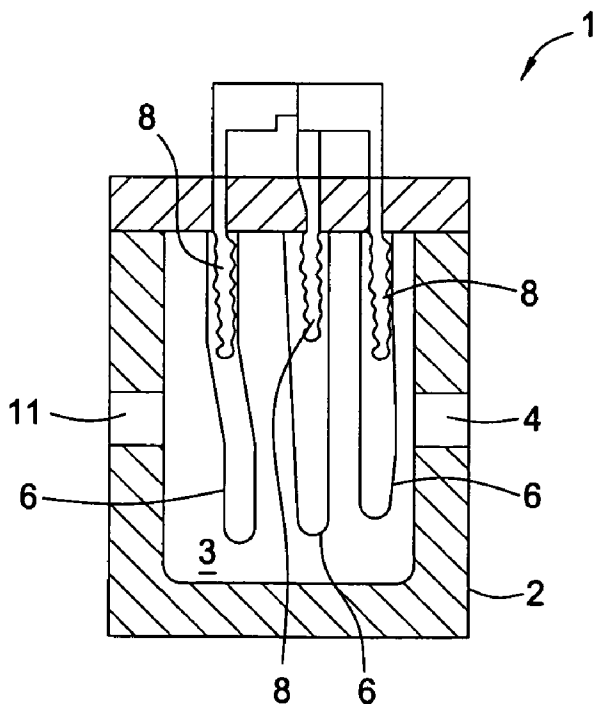

FIG. 2

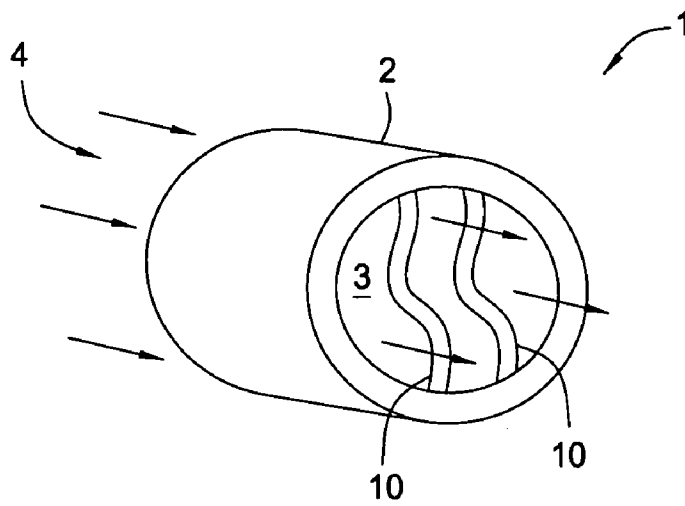

FIG. 3

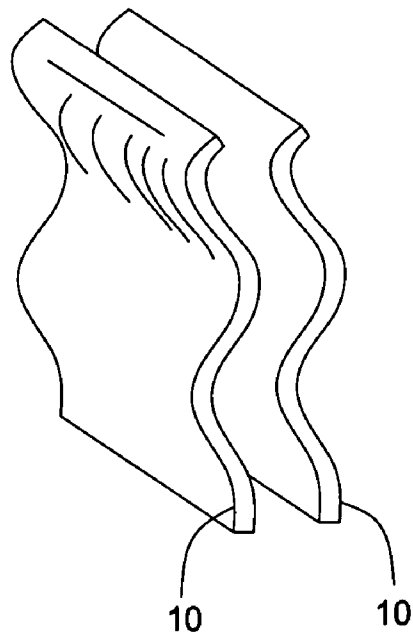

FIG. 4

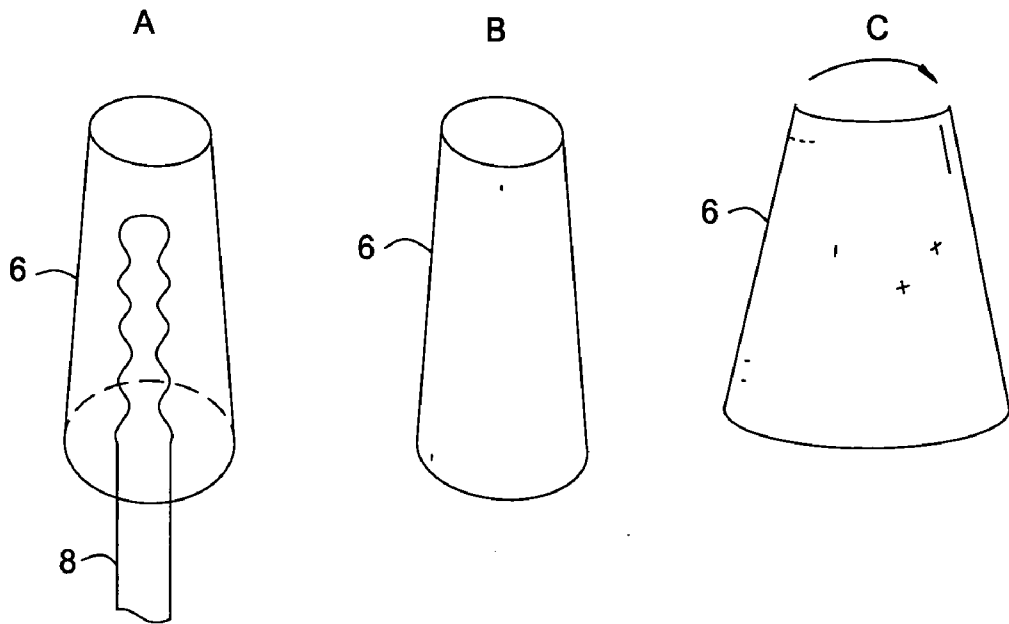

FIG. 5

APPARATUS AND METHOD FOR VAPORIZING SOLID PRECURSOR FOR CVD OR ATOMIC LAYER DEPOSITION

CROSS-REFERENCE TO RELATED APPLICATIONS

[0001] This application is a continuation of co-pending U.S. patent application Ser. No. 09/953,451, filed Sep. 14, 2001, and is herein incorporated by reference.

BACKGROUND OF THE INVENTION

[0002] 1. Field of the Invention

[0003] The present invention relates to the vaporization of solids. More particularly, the present invention relates to an apparatus and method for vaporizing solid precursors used in chemical vapor deposition and/or atomic layer deposition processes.

[0004] 2. Description of the Related Art

[0005] Chemical vapor deposition (CVD) and atomic layer deposition (ALD) are known techniques for forming solid films on a substrate by reaction of vapor phase chemicals near the surface of a substrate. In general, CVD and ALD techniques involve the delivery of gaseous reactants to the surface of a substrate where a chemical reaction takes place under temperature and pressure conditions favorable to the thermodynamics of the reaction. The type and composition of the layers that can be formed using CVD and/or ALD are limited by the ability to deliver the reactant(s) (otherwise known as precursor(s)) to the surface of the substrate. Various liquid precursors have been successfully used in CVD and/or ALD applications by delivering the liquid precursors in a carrier gas. Analogous attempts to deliver solid precursors to a CVD and/or an ALD reaction chamber have shown much less success.

[0006] In prior known solid precursor delivery devices, a carrier gas is passed through a heated container containing volatile solid precursor(s) at conditions conducive to vaporization of the solid. The carrier gas mixes with the vaporized solid and the vaporized solid is drawn from the container in a vacuum environment and carried with the carrier gas to the reaction chamber. Prior known solid precursor delivery procedures have been unsuccessful in reliably delivering solid precursor to the reaction chamber. For example, as the solid precursor is vaporized, the heat of vaporization needed to release the vaporized precursor molecules tends to cool underlying solid precursor molecules thus forming crystals, which tend to prevent or limit further vaporization of any underlying solid precursor.

[0007] Lack of control of solid precursor vaporization is, at least in part, due to the changing surface area of the bulk solid precursor as it is vaporized. Such a changing surface area when the bulk solid precursor is exposed to high temperature produces a continuously changing rate of vaporization, particularly for thermally sensitive compounds. This ever-changing rate of vaporization results in an inability to consistently contact the carrier gas with the solid material, which in turn results in a continuously changing and non-reproducible flow of vaporized solid precursor delivered for deposition in the reaction chamber. A predictable amount of precursor cannot therefore be delivered. As a result, film

growth rate and composition of such films on substrates in the reaction chamber cannot be controlled adequately and effectively.

[0008] U.S. Pat. No. 5,447,569 discloses the use of a tube containing a plurality of longitudinal slits, wherein vaporization of solid material packed within the tube is controlled by moving the tube through a band of heaters, wherein the vaporized material exits the tube perpendicularly to the longitudinal axis of the tube via the slits.

[0009] U.S. Pat. No. 5,674,574 discloses the use of a rotatable surface contained within a container. The rotatable surface, which has solid precursor material applied thereon, is heated using a focused thermal beam as it rotates. The vaporized solid exits the container through an outlet and is delivered to a reaction chamber.

[0010] U.S. Pat. No. 6,072,939 discloses the use of a hollow tube-like container having a longitudinal axis passing through a first end. The hollow container is attached to an injector that is in communication with an inlet of a reaction chamber. The injector moves the hollow container through a heater that vaporizes the solid material contained therein.

[0011] As discussed above, prior art methods, which use of elaborate systems to vaporize the solid precursor, have numerous disadvantages. Accordingly, there is a need in the art for a simplified vapor delivery system for delivering solid precursors at a highly controllable rate without decomposition of the solid precursors during vaporization. There is a further need in the art to both easily and efficiently vaporize a solid precursor at a controlled rate such that a reproducible flow of vaporized solid precursor can be delivered to the reaction chamber.

[0012] The present invention is directed to an apparatus and method for vaporizing solid precursors that overcomes the problems of the prior art so as to provide a simple, more efficient apparatus and method for vaporizing solid precursors in the formation of thin layers on substrates.

SUMMARY OF THE INVENTION

[0013] The present invention provides an apparatus for vaporizing solid precursors. The apparatus includes a housing defining a sealed interior volume having an inlet for receiving a carrier gas, at least one surface contained in the housing having a solid precursor applied thereon, and a heating member for heating the solid precursor. Although the heating member may or may not be contained within the surface supporting or containing the solid precursor, the heating member is preferably contained in the surface or surfaces contained within the housing.

[0014] The present invention also provides for a method for vaporizing solid precursors. The method involves applying a solid precursor to a surface located within a housing having a sealed interior volume. The surface is then heated either directly or indirectly by a heating element until a sufficient temperature is reached to vaporize the solid precursor.

[0015] According to one embodiment of the present invention, the surface supporting or containing the solid precursor includes one or more heated baffles or rods. A heating member may be contained within the baffles or rods. Addi-

tionally, the baffles or rods may conform to the shape of the heating member. For example, the baffles or rods may be cone-shaped to fit tightly over conventional cone-shaped heaters.

[0016] According to another embodiment of the present invention, the surface for the solid precursor includes one or more heated meshes or gratings. A heating member may be contained within the mesh or grating. The mesh or grating may conform in shape to maximize flow through of carrier gas (for example, the mesh or grating may be s-shaped).

[0017] In a preferred embodiment of the present invention, the vaporized precursor is mixed with a carrier gas and delivered to a reaction chamber where the vaporized precursor is deposited on the surface of a substrate by conventional deposition methods.

[0018] With the foregoing and other objects, advantages and features of the invention that will become hereinafter apparent, the nature of the invention may be more clearly understood by reference to the following detailed description of the preferred embodiments of the invention and to the appended claims.

BRIEF DESCRIPTION OF THE DRAWINGS

[0019] So that the manner in which the above recited features of the present invention can be understood in detail, a more particular description of the invention, briefly summarized above, may be had by reference to embodiments, some of which are illustrated in the appended drawings. It is to be noted, however, that the appended drawings illustrate only typical embodiments of this invention and are therefore not to be considered limiting of its scope, for the invention may admit to other equally effective embodiments.

[0020] FIG. 1 is a cross-sectional view of an apparatus for vaporizing a solid precursor in accordance with a first embodiment of the present invention.

[0021] FIG. 2 is a cross-sectional view of an apparatus for vaporizing a solid precursor in accordance with a second embodiment of the present invention.

[0022] FIG. 3 is a cross-sectional view of an apparatus for vaporizing a solid precursor in accordance with a third embodiment of the present invention.

[0023] FIG. 4 is a side view of the heated mesh used in the apparatus shown in FIG. 3.

[0024] FIGS. 5A-5C are side views of a cone-shaped rod with heating member inside (FIG. 5A); a cone-shaped rod without heating member (FIG. 5B); and folded cone mesh with solid precursor pressed in between wire mesh (or grating) (FIG. 5C), respectively.

DETAILED DESCRIPTION OF THE PREFERRED EMBODIMENT

[0025] The present invention provides an apparatus and method for vaporizing solid precursors. Referring to FIG. 1, the apparatus 1 includes a housing 2 defining a sealed interior volume 3 having an inlet 4 for receiving a carrier gas located at one end of housing 2. At least one surface 6 for supporting or containing a solid precursor is contained within housing 2. Surface 6 is preferably located on walls adjacent to the wall containing inlet 4. In the embodiment

shown in FIG. 1, a heating member 8 for heating a solid precursor applied to surface 6 is contained within at least one wall of housing 2. Optionally, an outlet 11 is provided on a wall of housing 2 opposite inlet 4. Preferably, outlet 11 is attached to a reaction chamber of a vapor deposition system.

[0026] An alternate embodiment of the apparatus of the present invention is set forth in FIG. 2. In this embodiment, a housing 2 is provided that includes an inlet 4 on one wall of the housing for receiving a carrier gas and optionally an outlet 11 on the wall opposite inlet 4. At least one surface 6 for supporting or applying a solid precursor is located on a wall adjacent to the wall containing inlet 4. A heating member 8 is located in surface 6 for heating a solid precursor affixed to surface 6.

[0027] FIG. 3 shows another embodiment of the present invention. In particular, a housing 2 defining a sealed interior volume having an inlet 4 for receiving a carrier gas is provided. At least one surface for supporting a solid precursor is affixed to the walls of housing 2 and is formed of one or more heated meshes or gratings 10. The mesh or grating 10 shown in FIG. 3 is s-shaped to allow for maximum flow through of a carrier gas. FIG. 4 provides a more detailed view of the mesh or grating 10 used in the apparatus of FIG. 3. Similar to the embodiments set forth in FIGS. 1 and 2, heating member 8 may be contained in the walls of housing 2 (not shown). Alternatively, heating member 8 may be contained within mesh or grating 10 (not shown).

[0028] The s-shape of the mesh or grating shown in FIG. 3 is not to be construed as limiting as other figures or shapes for surface 6 are within the scope of the invention. For example, if heating member 8 is contained within surface 6 which is formed of mesh or grating, surface 6 may be shaped to conform to the heating member. FIGS. 5A-5C depict surface 6 as a cone shaped rod that has been molded to conform to the shape of heating member 8. Typically, the shape chosen for surface 6 is one that provides the most surface area. By allowing more surface areas to be created in the same volume by applying solid precursor onto a surface, i.e., mesh, grating, baffles, or rods as in the present invention, the solid precursor has from about 100x to about 1000x more surface area to vaporize. This allows for a more efficient and faster vaporization. Additionally, with the help of the carrier gas, the flow of vapor through the housing can be better controlled.

[0029] Surface 6 is typically formed of a substance that can withstand the high temperatures needed to vaporize the solid precursors. Suitable examples of materials forming surface 6 include stainless steel and ceramics. Further, surface 6 may be in a staggered configuration as shown in FIG. 1, or in a flush (or even) configuration as shown in FIG. 2.

[0030] Any known solid precursor typically used in the production of semiconductor wafers can be used. Suitable preferred examples include $W(CO)_6$ and TaO_x precursors. The solid precursor may be applied to the surface by any means that will permit it to remain thereon. For example, the solid precursor may be pressed onto the surface to increase surface area for vaporization. This is an improvement over prior apparatus and methods, where vaporization was limited to the top surfaces of a solid material located in the bottom of a container. Alternatively, solid precursors may be dissolved in solution and the heating element may be dipped

into the solution. After it is allowed to dry, the solid is retained on the heating element. A rough surface on the heating element may improve adhesion of the solid precursor to the heating element.

[0031] In previous systems, when the carrier gas was blown through the powdered solid precursor, the gas picked up some of the loose precursor particles and carried the loose particles out onto the wafer surface, thereby contaminating the wafer. However, in the present invention, the use of surface 6 to hold the solid precursor permits better handling of the solid material, thereby reducing the risk of the solid material flowing with the carrier gas out into the reaction chamber.

[0032] To vaporize a solid precursor using the apparatus set forth in FIG. 1, a solid precursor is first applied to surface 6. The said precursor can be applied by pressing the precursor onto surface 6 or by "dipping" the heating element into the dissolved precursor as discussed above. The solid precursor is then heated, either directly by heating member 8 located inside surface 6, or indirectly by heating element 8 located inside the walls of housing 2, until a temperature high enough to vaporize the solid precursor is reached. The vaporization temperature will vary depending on the solid substrate applied to surface 6. A carrier gas enters housing 2 through inlet 4 and carries the vaporized solid precursor to a reaction chamber (not shown) via outlet 11. Once the vaporized precursor reaches the reaction chamber, it is deposited onto the surface of a substrate (e.g., semiconductor wafer) by conventional deposition methods such as atomic layer deposition (ALD), chemical vapor deposition methods (CVD), and evaporative coating (i.e., the redeposition of substance from precursor onto wafer or substrate).

[0033] The invention of this application is described above both generically, and with regard to specific embodiments. A wide variety of alternatives known to those of ordinary skill in the art can be selected within the generic disclosure, and examples are not to be interpreted as limiting, unless specifically so indicated. The invention is not otherwise limited, except for the recitation of the claims set forth below.

[0034] Although the invention has been described with some particularity with respect to preferred embodiments thereof, many changes could be made and many alternative embodiments could thus be derived without departing from the scope of the invention.

1. An apparatus for vaporizing a solid precursor, comprising:

a housing defining an interior volume having an inlet for receiving a carrier gas;

at least two surfaces contained in the housing, wherein the at least two surfaces have the solid precursor applied thereto and are spaced to allow passage of the carrier gas therebetween; and

at least one heating member contained in the housing.

2. The apparatus of claim 1, wherein the apparatus further comprises an outlet operably connected to a reaction chamber of a deposition chamber.

3. The apparatus of claim 2, wherein the at least two surfaces are selected from the group consisting of a baffle, a rod, a mesh and a grating.

4. The apparatus of claim 1, wherein the at least two surfaces have a form selected from the group consisting of an s-shape, a linear shape and a cone shape.

5. The apparatus of claim 3, wherein the at least two surfaces are formed of a material selected from the group consisting of stainless steel and ceramic.

6. The apparatus of claim 2, wherein the deposition chamber is selected from the group consisting of ALD chamber, CVD chamber, and evaporative coating chamber.

7. The apparatus of claim 6, wherein the solid precursor includes a tantalum-containing precursor or a tungsten-containing precursor.

8. An apparatus for vaporizing a solid precursor, comprising:

a housing defining an interior volume having an inlet for receiving a carrier gas and an outlet for delivering the carrier gas and a vaporized solid precursor, wherein the vaporized solid precursor originates from the solid precursor;

a first wall to support the inlet;

at least one surface contained in the housing for application of the solid precursor, wherein the at least one surface is located on a second wall adjoining to the first wall and the at least one surface is spaced to allow passage of the carrier gas; and

a heating member contained in the housing.

9. The apparatus of claim 8, wherein the outlet is operably connected to a reaction chamber of a deposition chamber.

10. The apparatus of claim 9, wherein the at least one surface is selected from the group consisting of a baffle, a rod, a mesh and a grating.

11. The apparatus of claim 8, wherein the heating member is contained within the at least one surface.

12. The apparatus of claim 9, wherein the at least one surface has a form selected from the group consisting of an s-shape, a linear shape and a cone shape.

13. The apparatus of claim 12, wherein the at least one surface is formed of a material selected from the group consisting of stainless steel and ceramic.

14. The apparatus of claim 9, wherein the deposition chamber is selected from the group consisting of ALD chamber, CVD chamber, and evaporative coating chamber.

15. The apparatus of claim 14, wherein the solid precursor includes a tantalum-containing precursor or a tungsten-containing precursor.

16. An apparatus for vaporizing a solid precursor, comprising:

a housing defining an interior volume having an inlet for receiving a carrier gas and an outlet for delivering the carrier gas and a vaporized solid precursor, wherein the vaporized solid precursor originates from the solid precursor;

at least two surfaces contained in the housing, wherein the at least two surfaces have the solid precursor applied thereto and are spaced to allow passage of the carrier gas therebetween; and

at least one heating member contained in at least one wall of the housing.

17. The apparatus of claim 16, wherein the at least two surfaces is selected from the group consisting of a baffle, a rod, a mesh and a grating.

18. The apparatus of claim 16, wherein the outlet is operably connected to a reaction chamber of a deposition chamber.

19. The apparatus of claim 18, wherein the deposition chamber is selected from the group consisting of ALD chamber, CVD chamber, and evaporative coating chamber.

20. The apparatus of claim 19, wherein the solid precursor includes a tantalum-containing precursor or a tungsten-containing precursor.

* * * * *