

(19) World Intellectual Property
Organization
International Bureau



(43) International Publication Date
1 July 2004 (01.07.2004)

PCT

(10) International Publication Number
WO 2004/056157 A1

(51) International Patent Classification⁷: **H05B 37/02**

(21) International Application Number:
PCT/IB2003/005927

(22) International Filing Date: 8 December 2003 (08.12.2003)

(25) Filing Language: English

(26) Publication Language: English

(30) Priority Data:
60/433,750 16 December 2002 (16.12.2002) US

(71) Applicant (for all designated States except US): **KONINKLIJKE PHILIPS ELECTRONICS N.V.** [NL/NL];
Groenewoudseweg 1, NL-5621 BA Eindhoven (NL).

(72) Inventors; and

(75) Inventors/Applicants (for US only): **WANG, Ling**
[US/US]; P.O. Box 3001, Briarcliff Manor, NY
10510-8001 (US). **GIANNOPOULOS, Demetri**
[US/US]; P.O. Box 3001, Briarcliff Manor, NY
10510-8001 (US).

(74) Common Representative: **KONINKLIJKE PHILIPS ELECTRONICS N.V.**; c/o Waxler, Aaron, P.O. Box
3001, Briarcliff Manor, NY 10510-8001 (US).

(81) Designated States (national): AE, AG, AL, AM, AT, AU, AZ, BA, BB, BG, BR, BY, BZ, CA, CH, CN, CO, CR, CU, CZ, DE, DK, DM, DZ, EC, EE, EG, ES, FI, GB, GD, GE, GH, GM, HR, HU, ID, IL, IN, IS, JP, KE, KG, KP, KR, KZ, LC, LK, LR, LS, LT, LU, LV, MA, MD, MG, MK, MN, MW, MX, MZ, NI, NO, NZ, OM, PG, PH, PL, PT, RO, RU, SC, SD, SE, SG, SK, SL, SY, TJ, TM, TN, TR, TT, TZ, UA, UG, US, UZ, VC, VN, YU, ZA, ZM, ZW.

(84) Designated States (regional): ARIPO patent (GH, GM, KE, LS, MW, MZ, SD, SL, SZ, TZ, UG, ZM, ZW), Eurasian patent (AM, AZ, BY, KG, KZ, MD, RU, TJ, TM), European patent (AT, BE, BG, CH, CY, CZ, DE, DK, EE, ES, FI, FR, GB, GR, HU, IE, IT, LU, MC, NL, PT, RO, SE, SI, SK, TR), OAPI patent (BF, BJ, CF, CG, CI, CM, GA, GN, GQ, GW, ML, MR, NE, SN, TD, TG).

Declaration under Rule 4.17:

— as to applicant's entitlement to apply for and be granted a patent (Rule 4.17(ii)) for all designations

Published:

— with international search report
— before the expiration of the time limit for amending the claims and to be republished in the event of receipt of amendments

For two-letter codes and other abbreviations, refer to the "Guidance Notes on Codes and Abbreviations" appearing at the beginning of each regular issue of the PCT Gazette.

(54) Title: SYSTEM AND METHOD FOR LIGHTING CONTROL NETWORK RECOVERY FROM MASTER FAILURE

(57) Abstract: The present invention provides a master-slave architecture for a radio frequency RF networked lighting control system having all slave elements (ballasts) configured as backups for a network master control unit. In the system and method of the present invention a slave element can become the network master network unit without reconfiguring the network and without any human intervention. Similarly, both a master and one or more slave elements may recover from a temporary outage without necessitating reconfiguration of the network and without any human intervention.



WO 2004/056157 A1

**SYSTEM AND METHOD FOR LIGHTING CONTROL NETWORK RECOVERY
FROM MASTER FAILURE**

This invention is related to recovering the ballast control in a wireless lighting control
5 network when the main controller (master) fails. More particularly, this invention is related
to a wireless lighting control network system and method in which all lighting ballasts act as
backups for a network master control unit. Most particularly, this invention is related to a
system and method for a master-slave architecture for a wireless lighting control network that
include all lighting ballasts as backup for a network master control unit such that there is no
10 need for reconfiguration of the network or human intervention when a master fails or
functioning of the master or slave ballasts is interrupted.

Traditional lighting has wall switches wired to the ballasts individually or in groups.
If one of the switches fails, the ballasts that are controlled by other switches won't be
affected. In wireless control, the on/off or light intensity is controlled by the signals
15 transmitted from a remote table-top or handheld control unit via infra-red (IR) or radio
frequency (RF) communication media.

There are basically two types of system configurations in wireless control. One is a
distributed system that has several remote control units, each remote unit controlling a certain
number of ballasts through the wireless links. The ballasts obtain the IDs of their designated
20 controllers during the initialization of the system. Then, during normal operation the ballasts
"listen" and react to the lamp operational signals coming transmitted by these controllers.
The systems described in U.S. Patent No. 5,848,054 to Mosebrook et al. and U.S. Patent No.
6,174,073 to Regan, fall into this category.

The other type of system is a master-slave oriented networked architecture, which is
25 the focus of this invention. There is one central device, so called "master" or "network

coordinator” that manages communication among the network nodes. The ballasts and the remote controls both act as the slaves in the network. All the information about the wireless links between the keys on the remote control and the ballasts is gathered in a table stored in the master during initial configuration of the system. During the normal operation, the signal
5 transmitted by a remote control is routed to its destination ballast by the master based on the link information in the table. The physical form of the master can be the same as a slave device, i.e. the master can reside in the remote control or the ballast. It is preferable to put the master in the ballast as it is mains-powered and at a fixed location. Connecting to the mains allows the master to transmit beacon packets that contain the master status information
10 as a way to keep the slaves in touch every once in a while. Being at a fixed location avoids problems a missing handheld remote control since all the network information is lost in such a case.

The master-slave networked system has the following advantages over the distributed system:

- 15 • If more than one remote-control is needed in a multi-zone office, a separate master is essential for network recovery if a remote control is lost.
- A master-slave architecture centralizes the control information for the local network and makes it easier to form the building-wide network.

In both wireless systems, there could be several reasons for a system failure:

- 20 • Power Loss: In normal operation, the ballasts should not be cut off from the mains power for any reason, as they have to keep the RF communication alive all the time. Turning-off the lamps only puts the lamp-drivers in stand-by in digital ballasts, and it does not shut off the power supply to the circuits. Sometimes the controller that happens to be installed on a different mains power line from the

ballasts experiences a power outage. Other times the controller could be running out of battery if battery powered.

- Circuit malfunction: This includes circuit failures in the master control unit (MCU) or RF transceiver, and the temporary RF signal blockage/shielding or interference such that the communications between the devices are blocked.
- Master Control Unit Failure: In a wireless network the master control unit represents a single point of failure. That is, once the master fails, all link information kept only by the master is lost. In a point-to-point network the network is no longer operable. This also occurs because the master routes all the packets and the master fails.

There are several ways to enhance the reliability. The wireless system taught by US Pat. No. 5,848,054 to Mosebrook et al., increases the reliability communications by adding repeaters between the source and destination devices. When the master and the ballasts suffer from intermittent communication in the direct path due to distance or RF interference, a repeater provides an additional communication path. However, this does not solve the problem of the master going completely dead.

Another system, taught by EP0525133 to Edwards et al., solves the master power outage problem by providing a battery as a back-up power source. When AC power is available, the battery is being charged. When the AC is cut off, the power supply automatically switches to the battery. Even though this idea teaches a battery backup for conventional hardwired lighting systems, it can be applied to the wireless system too. However, it can be costly to provide an additional power supply to every control device.

In a master-slave networked system, due to the important role of the master, it is critical to make sure that there is always a master working properly at all times. If the controller fails due to a power outage (dead battery) or malfunction, the problem arises of to

how to regain controls of the ballasts. New replacements can be brought in, but the configuration, such as which key to control which ballasts, has to be set up again since there is no hardwiring in a wireless control system. Depending on how the wireless control network is built in the first place, sometimes this may mean starting the configuration from scratch all over again.

The present invention solves the problems associated with a single master, as discussed above, by providing multiple back-up masters in a master-slave orientated control network. The system and method of the present invention enhances system reliability without an extra device or costly circuitry. Each ballast in the network has the potential to be a master when needed. This means each device needs a little bit of extra memory to store the master program. In a digital ballast, the cost for additional memory is minimal.

The master malfunction is automatically detected by the slaves in the network. Once a master fails, a back-up master takes control of the network following a pre-established protocol or algorithm of a preferred embodiment. The network recovery takes place automatically and is transparent to the end user. There is no need to set up the network control configuration again.

The original master resides in one of the ballasts after the installation and configuration of the network, which includes the physical installation, registration of the ballasts with the network master (so called "enumeration"), and associating the ballasts with certain buttons on the remote control (so called "binding").

All the ballasts (slaves in the network) have the possibility and capability of becoming the new master if needed. It is randomly decided, when necessary, which ballast is the next back-up master. There is no priority number assigned before hand.

FIG. 1 illustrates a flowchart of the back-up master operation taking over control of the network.

FIG. 2 illustrates the failure of a network master control unit and several slaves of the same wireless lighting network.

FIG. 3 illustrates recovery of a network master control unit from a power outage.

5

The wireless lighting control network functions analogously to a wireless communication network. The lighting network itself is identified by a network ID, which is the essential information for communication among all the network nodes and there is a several layer communication protocol stack associated with every component of the wireless lighting network. After the network is established by the master and an enumeration of the lighting elements and pairing of enumerated lighting elements with keys are done, the master has all the pairing information stored in a pairing-link table in the protocol stack. Each pairing-link table entry specifies which ballast(s) reacts to which key and on which remote control. The master transfers this pairing-link table to all the slaves in the network. Every time the pairing-link table is changed, the master keeps all the slaves updated.

Master and slaves exchange status information at pre-determined intervals to make sure that the master is working properly. The master sends out beacon packets that contains status information at these certain intervals. The slaves receive the beacon packets and determine the state of the master. As illustrated in FIG. 1, at step 11 slaves also wake up a master that is in its sleep mode at intervals t_1 . Each slave keeps in touch with the master with the same interval but at a different point of time (based on a randomly generated number).

Once a slave finds that the master is not working, at step 13 it waits a certain delay time t_2 before taking any action in case the master become operational again. Once the delay is timed out, at step 15 the first slave who discovers the master-failure will start to convert itself to the new master. While the first slave is waiting, the rest of the slaves can find out the

master-failure too, but all of them have to wait for the same delay t_2 before reacting, so the first to discover the master outage becomes the new master.

The new master switches to the master status using the master code that has already been stored in its memory.

5 The new master establishes the network using the same network ID that the previous master used, providing this network ID is not used by any other networks in the vicinity. Then the application layer of the master does the following, as shown in FIG. 1.

1. Informs the lower layers in the new master to act as a master (sending beacons...) using the same network ID.
- 10 2. At step 15 informs the slaves that a new master is taking over the network and they should synchronize with the new master in terms of listening to the beacons and checking the master's status.
3. At step 16 updates the pairing-link table and transmits a copy of it to all the slaves.

The algorithm of the present invention can be implemented in combination with a
15 wireless communication protocol, either proprietary or open standard to ensure a reliable RF communication such as Zigbee™. Zigbee™ is a low cost, low power consumption, two-way, wireless communications standard aimed initially at automation, toys, & PC peripherals, and is a good candidate for implementing this system and method of the present invention for a recoverable RF wireless lighting control network that uses slaves as backup masters.

20 Normal Operation

The very first time the system is installed, the master and slaves all take on the physical format of a ballast. In a preferred embodiment, their roles are distinguished by certain mechanisms or algorithms. In a given single room, there must be a master and at least one slave. All the devices, including master and slaves, have nonvolatile memories (NVM) to
25 store the enumeration status information, network ID information and pairing-link table

information. When the devices are initially powered up, the master checks its NVM to see if it has been in any network as a master before. If not, it establishes its network using a randomly generated network ID. The slaves check their NVMs to see if they have been in any network as a slave before, if not, they try to enumerate to a master available in their RF vicinity. Once they are connected to a master, the lamp flashes to provide feedback to the user and the user presses a button on the remote control to confirm that it should be included in the network. The remote control is also a slave to this network and has to be connected to the master before the ballasts.

10 Reasons for Master Failure

There are two major reasons for the master to fail:

1. Power Loss: During normal operation, both master and slave must not be cut off from the main power supply for any reason, as they have to keep the RF communication alive all the time. Turning off the lamps only puts the lamp drivers in stand-by, and it does not shut off the power supply to the circuits. When the ballasts are initially powered up from the main power supply, if a ballast is supposed to be a master, it starts to establish its network. If it is supposed to be a slave, it starts to request joining a network. The ballasts store their IDs and network connection information (such as the pairing-link table, the flag indicating if it has been enumerated before, etc.) in the non-volatile memory so that the network connection can be recovered after a temporary power interruption. If the power of the whole system is consistently interrupted, then the ballasts maintain their previous roles after the power comes back. In this case, the power-up reset does not trigger the enumeration request in the ballast if it was already in a network previously. This scenario is not considered a master failure since the whole network recovers to its previous state before the power interruption without further procedures being invoked.

However, sometimes the master could be installed on a different main power line from the slaves. When its power is experiencing an outage and the one for the slaves is not, a back-up master is needed to keep the rest of the slaves under control.

2. Circuit malfunction: This includes failures in the MCU or transceiver and temporary
5 RF signal blockage/shielding around the master, etc. In this case, a back-up master is also
necessary to recover the operation of all the slaves.

FIG. 2 illustrates the master failure situation. If a circuit malfunction occurs and the
network master control unit 22 is not functional, a new master control unit 28 takes over
control of the existing lighting network by following the algorithm illustrated in FIG. 1. By
10 way of example only, several slaves and a network master control unit 22 are shown in a non-
working circuit in FIG. 2. The new network master control unit 28 takes control of the
existing lighting network 20, updates its pairing-link table to reflect these non-working units
and transmits the updates to all the working slaves in the network.

Disabled Master Coming Back

15 In the case that the previous master recovers from its temporary RF blockage or
power outage, it tries to join the same network again, but not as a master, instead, as a slave
since there a new master has already taken over control of the network. The following
describes the two different situations where the previous master recovers from a temporary
power outage and RF blockage. If the previous master failure is due to circuit malfunction, it
20 cannot recover anyway.

1. Coming back from temporary power outage

Referring now to FIG.3, when the previous master regains power 31, it goes through
the power-up reset and then checks the contents of its NVM. When its NVM indicates that it
was previously the master of a network 34, it tries to recover its role as master in the same
25 network by attempting to establish its network using the same network ID 34. It starts the

search at this particular network identifier, and then listens for a beacon packet to see if anyone else is already using this network ID 35. As soon as it finds out that another device has already taken its place as the master in this particular network (using the previous network ID), it withdraws itself from attempting to become the master again, and it
5 enumerates to the network as a slave 36. Since the network ID is still the same, it does not require any user intervention during the enumeration.

As can be seen in FIG. 3, some of the slaves might have been out of power, as well, if they were on the same power line as the previous master. When they regain power, they go through power-up reset and then check the contents of their NVMs. As their NVMs indicate
10 that they were was previously slaves of a network, they try to recover this role as a the slave 36, in the same network by attempting to enumerate using the previous network ID. The new master is able to accept them without user intervention since the new master has the information that the slave has been in this network before the power was out.

2. Coming back from temporary RF communication blockage

15 When the previous master failure is due to the temporary RF communication blockage, the protocol stack is able to report this problem to the application layer. The application layer then goes back to the beginning of the routine, which is power-up reset. Then it keeps trying to re-establish its network using the same network ID 38. If, by the time the RF channel is clear for communication for this device, the new master has already taken
20 over the network, the old master withdraws from trying to become the master, but tries to become a slave, which is the same as the situation in coming back from temporary power outage and is discussed above and illustrated in FIG. 3.. If by the time the old master regains RF accessibility, \the new master has not yet taken control of the network, the old master recovers control over the same network with the same ID and this is illustrated in FIG. 3.

Although the present invention has been described in relation to particular embodiments thereof, many other variations and modifications and other uses will be apparent to those skilled in the art. The present invention, therefore, should be limited not by the specific disclosure herein, but only by the appended claims.

CLAIMS:

1. A lighting control network recovery system for a wireless network of lighting elements, comprising:

a plurality of ballasts (29) each of said plurality of ballasts being configured both as a slave element and a replacement network master control unit;

one of said plurality of ballasts configured as a network master control unit (23) to control each of said plurality of ballasts as a slave element,

wherein, when a network master control unit no longer functions (23), one of said plurality of ballasts configured as a replacement network master control unit (28) (29) takes its place by becoming a new network master control unit (28) and taking control of the lighting control network.

2. The system of claim 1, further comprising:

at least one remote control unit having a plurality of keys; and

at least one main power line having said ballasts connected thereto such that:

a. the one of said ballasts that is configured as a network master control unit (23) is adapted to setup the network configuration of the lighting control network on power-up reset by recording the registration of each slave element and the association of each slave element with at least one key of the at least one remote control and to control said lighting control network thereafter, and

b. each of said plurality of ballasts (29), other than said network master control unit (23), that is configured as a slave element (29) is adapted to join a lighting control network on power-up reset by registering with the network master control unit (28) and associating with at least one of said plurality of keys of said at least one remote control unit.

3. The system of claim 2, wherein said at least one remote control unit is configured as a slave element and said at least one remote control unit is connected first to the network master control unit (28) before any of said plurality of ballasts configured both as a slave element and a replacement network master control unit (29).

4. The system of claim 2, further comprising:

a non-volatile memory (NVM) associated with the network master control unit and each said slave element; and

a pairing-link table stored in the non-volatile memory of the network master control unit and each slave element, having an initialization as empty and adapted to store

c. a registration termed an "enumeration" of each said slave element that registers with the network master control unit such that the slave element is listed in the pairing link table of the network master control unit, and

d. a binding of each said slave element listed in said pairing-link table with at least one of said plurality of keys of said at least one remote control unit, such that the binding is recorded in the pairing link table of the network master control unit,

wherein, the network is established by the network master control unit once setup is accomplished and every time the pairing-link table is updated the network master control unit transmits the update to each said slave element.

5. The system of claim 4, further comprising:

a periodically transmitted beacon packet by the network master control unit to each said slave element, said packet having status information of the network master control unit and being transmitted with frequency F ;

a periodically transmitted wakeup message (11) by each said slave element to the network master control unit, said message being transmitted with the predetermined frequency $F(t_i)$ and at a predetermined point in time;

wherein, when a slave element determines that the master is not working from at least one of the status beacon packet and the wakeup message, the slave element waits a given delay time D (13) and then starts to convert itself (15) to a new network master control unit such that the first said element to discover the network master control unit is not working becomes a new network master control unit and such that network recovery takes place automatically with no need to set up the network control configuration again, and

wherein the new network master control unit switches to master status using a master code that has already been stored in its memory, establishes a new network using a same network ID that the previous network master control unit used and begins to act as a network master control unit for the new network using the same network ID, informs each said slave element to listen for a beacon from the new network master control unit and to send a wake up message to the new network master control unit, and updates the pairing-link table of the new network master control unit and transmits the updated pairing-link table (16) to each said slave element for storage in its NVM.

6. The system of claim 2, wherein on power-up reset

if the network master control unit has a network ID stored in its non-volatile memory (33) then it has been a master before and if the ID is in use (35) the network master control unit enumerates (36) as a slave element to the new master of the network with the ID, and if the ID is not in use then the network master control reestablishes that network using the ID (38) and pairing-link table so that the network can be recovered after a temporary power interruption, otherwise it has not been a master before, a random ID is generated and stored in

its non-volatile memory and its network is established having the randomly generated network ID; and

f. if the slave element has a network ID stored in its non-volatile memory it has been a slave element in that network before and it rejoins that network so that the network connection is recovered after a temporary power interruption, otherwise it has not been a slave element in a network before and it tries to enumerate to a network master control unit in its radio frequency vicinity.

7. The system of claim 6, wherein the system is implemented using a low power consumption, two-way wireless communication standard having a protocol and comprising a radio, a physical layer, a data link layer, and a an application layer.

8. The system of claim 7, wherein the two-way wireless communication standard is Zigbee™ and the protocol is Protocol for Universal Radio Link (PURL).

9. A method for recovery control of a wireless lighting control network, comprising the steps of:

providing a plurality of ballasts (29) wherein each of said plurality of ballasts is configured both as a slave element and a replacement network master control unit (28) (29);

providing one of said provided plurality of ballasts configured as a network master control unit (23) to control each of said plurality of ballasts as a slave element;

when the network master control unit no longer functions (28), replacing the network master control unit (23) with one of said plurality of provided ballasts configured as a replacement network master control unit; and

communicating with each slave element to become a new network master control unit and take control of the lighting control network. by the replacement network master control unit.

10. The method of claim 9, further comprising the steps of:
 - providing at least one remote control unit having a plurality of keys;
 - providing at least one main power line having said ballasts connected thereto;
 - on power-up reset performing the steps of:
 - i. setting up the network configuration of the lighting control network by the network master control unit, by performing the substeps of -
 - registering each said slave element with the network master, and
 - associating each registered slave element with one of said plurality of keys of said at least one remote control unit; and
 - ii. controlling the lighting control network by the network master control unit.

11. The method of claim 10, further comprising the steps of:
 - configuring said at least one remote control unit is as a slave element, and
 - registering said at least one remote control unit with the network master control unit first.

12. The method of claim 10, further comprising the steps of:
 - associating a non-volatile memory with the network master control unit (23) and each said slave element (29);

providing a pairing-link table in the non-volatile memory of the network master control unit (23);

initializing each said provided pairing-link table as empty;

enumerating each said slave element that registers with the network master control unit in the pairing link table of the network master control unit (28);

binding each said slave element enumerated in said pairing-link table with at least one of said plurality of keys of said at least one remote control unit;

recording the bound slave element and its corresponding remote control key as updates in the pairing link table of the network master control unit;

informing each slave element (29) of the recorded update made by the network master control unit to its pairing-link table; and

updating by the slave element of its pairing-link table with the information of the recorded updates made by the network master control table.

13. The method of claim 12, further comprising the steps of:

periodically and at a frequency F , transmitting a beacon packet by the network master control unit to each said slave element (29) that includes status information of the network master control unit;

periodically and at a frequency F and at a predetermined point in time, transmitting a wakeup message (11) by each said slave element to the network master control unit;

when a slave element determines that the master is not working (12) from at least one of the transmitted status beacon packet and wakeup message, performing the following steps:

- a. waiting a given delay D by the slave element (13), and
- b. when D times out, converting itself by the slave element to a new network master control unit (15);

when a master code is already stored in the memory of the new network master control unit, establishing a network with the same network ID that the previous network master control unit used (15);

beginning to act as a network master control unit for the new network;

informing each said slave element (29) to listen for a beacon from the new network master control unit (28) and to send a wake up message to the new network master control unit (28);

updating the pairing-link table of the new network master control unit; and

transmitting the updated pairing-link table to each said slave element.

14. The method of claim 10, on power-up reset further performing the steps of:

enumerating as a slave element to a new network master control unit with this ID if the network master control unit has a network ID stored in its memory that is already in use (36);

reestablishing the network by the network master control unit with its stored ID if it is not in use and with its stored pairing-link table (38);

when there is no network ID stored in the memory of the network master control unit, performing the steps of:

- a. randomly generating a network ID,
- b. storing the ID in its non-volatile memory, and
- c. establishing its network using the randomly generated network ID, and

if a slave element has a network ID stored in its non-volatile memory, rejoining that network by the slave element; and

if a slave element does not have a network ID stored in its non-volatile memory, trying to enumerate to a network master control unit in its radio frequency vicinity by the slave element.

15. A system with a low power consumption, two-way wireless communication standard having a protocol and comprising a radio, a physical layer, a data link layer, and an application layer that performs the method of claim 14.

16. The system of claim 15, wherein the two-way wireless communication standard is Zigbee™ and the protocol is Protocol for Universal Radio Link (PURL).

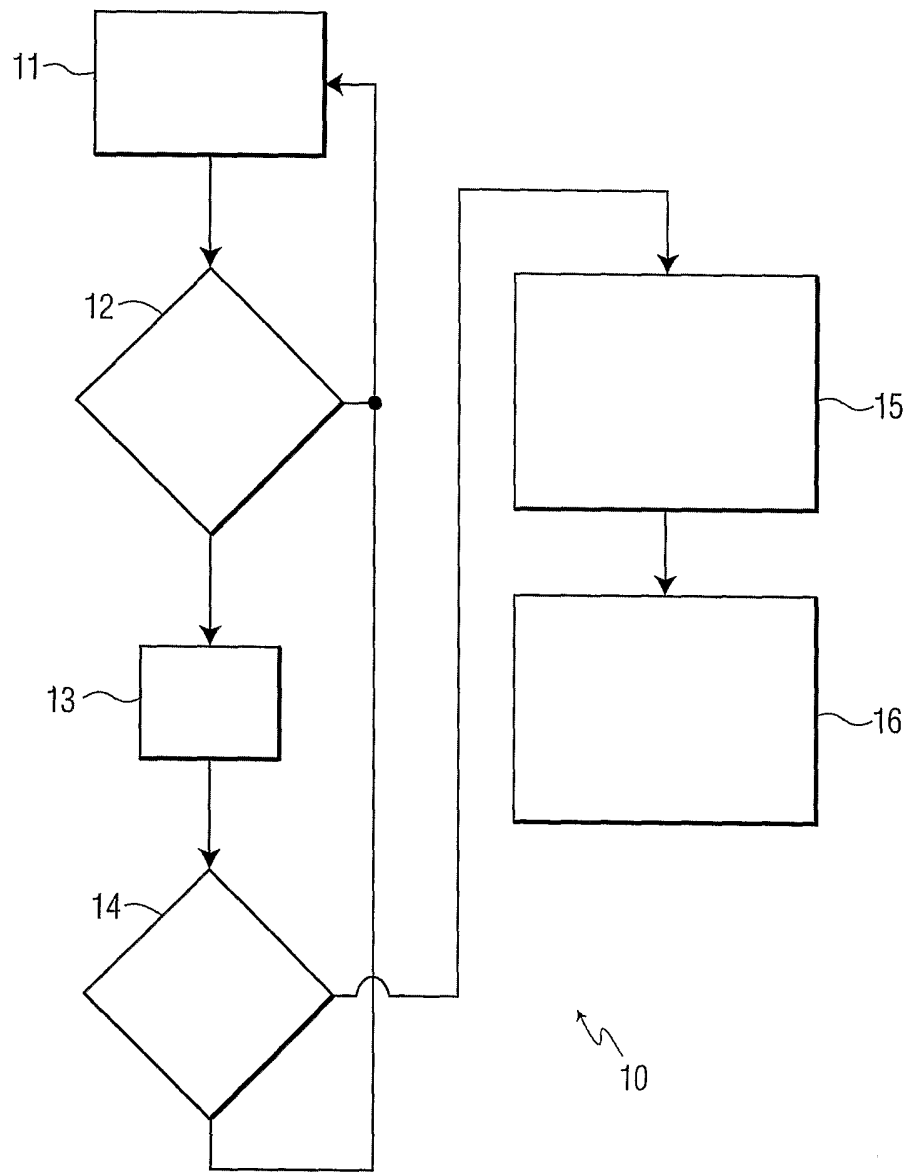

FIG. 1

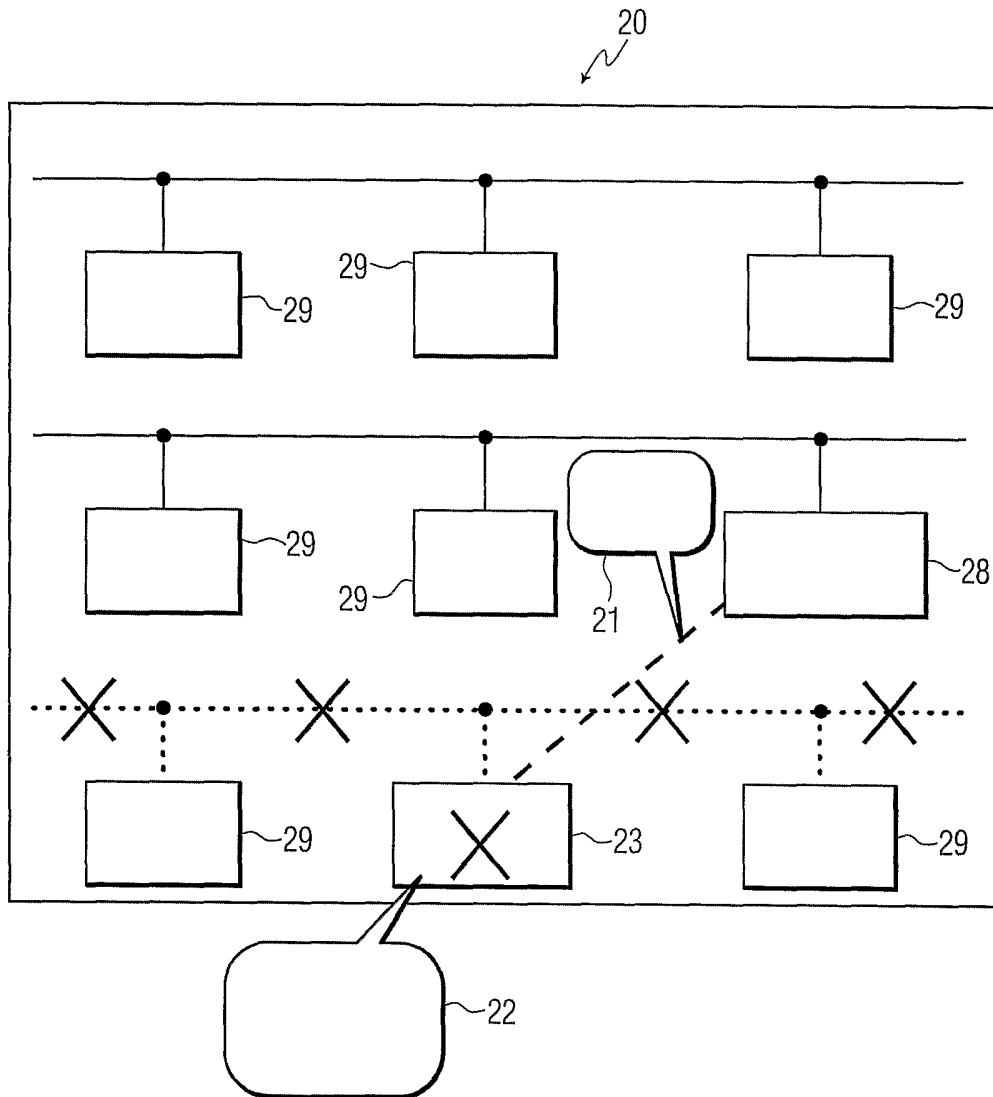

FIG. 2

3/3

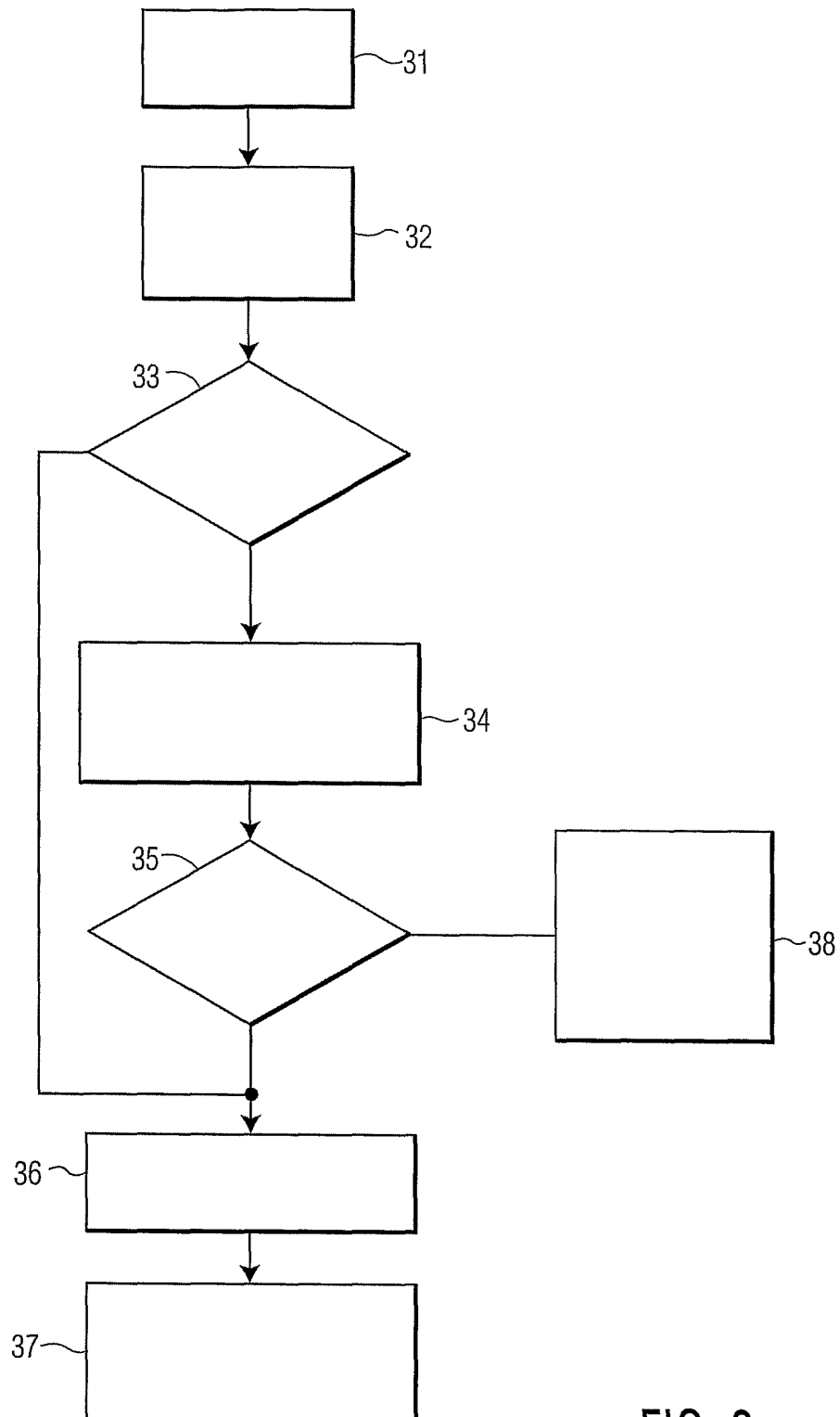

FIG. 3

INTERNATIONAL SEARCH REPORT

International Application No
PCT/IB 03/05927

A. CLASSIFICATION OF SUBJECT MATTER IPC 7 H05B37/02				
According to International Patent Classification (IPC) or to both national classification and IPC				
B. FIELDS SEARCHED				
Minimum documentation searched (classification system followed by classification symbols) IPC 7 H04L H05B				
Documentation searched other than minimum documentation to the extent that such documents are included in the fields searched				
Electronic data base consulted during the international search (name of data base and, where practical, search terms used) EPO-Internal, PAJ				
C. DOCUMENTS CONSIDERED TO BE RELEVANT				
Category °	Citation of document, with indication, where appropriate, of the relevant passages	Relevant to claim No.		
Y	EP 1 176 762 A (SAMSUNG ELECTRONICS CO LTD) 30 January 2002 (2002-01-30) abstract paragraph '0038! method for recovering a bluetooth network when master disappears	1-16		
Y	----- PATENT ABSTRACTS OF JAPAN vol. 1998, no. 10, 31 August 1998 (1998-08-31) & JP 10 126861 A (MATSUSHITA ELECTRIC WORKS LTD), 15 May 1998 (1998-05-15) abstract wireless lighting control network with a master slave structure ----- -/--	1-16		
<input checked="" type="checkbox"/> Further documents are listed in the continuation of box C.				
<input checked="" type="checkbox"/> Patent family members are listed in annex.				
° Special categories of cited documents :				
<table style="width: 100%; border: none;"> <tr> <td style="width: 50%; border: none; vertical-align: top;"> *A* document defining the general state of the art which is not considered to be of particular relevance *E* earlier document but published on or after the international filing date *L* document which may throw doubts on priority claim(s) or which is cited to establish the publication date of another citation or other special reason (as specified) *O* document referring to an oral disclosure, use, exhibition or other means *P* document published prior to the international filing date but later than the priority date claimed </td> <td style="width: 50%; border: none; vertical-align: top;"> *T* later document published after the international filing date or priority date and not in conflict with the application but cited to understand the principle or theory underlying the invention *X* document of particular relevance; the claimed invention cannot be considered novel or cannot be considered to involve an inventive step when the document is taken alone *Y* document of particular relevance; the claimed invention cannot be considered to involve an inventive step when the document is combined with one or more other such documents, such combination being obvious to a person skilled in the art. *&* document member of the same patent family </td> </tr> </table>			*A* document defining the general state of the art which is not considered to be of particular relevance *E* earlier document but published on or after the international filing date *L* document which may throw doubts on priority claim(s) or which is cited to establish the publication date of another citation or other special reason (as specified) *O* document referring to an oral disclosure, use, exhibition or other means *P* document published prior to the international filing date but later than the priority date claimed	*T* later document published after the international filing date or priority date and not in conflict with the application but cited to understand the principle or theory underlying the invention *X* document of particular relevance; the claimed invention cannot be considered novel or cannot be considered to involve an inventive step when the document is taken alone *Y* document of particular relevance; the claimed invention cannot be considered to involve an inventive step when the document is combined with one or more other such documents, such combination being obvious to a person skilled in the art. *&* document member of the same patent family
A document defining the general state of the art which is not considered to be of particular relevance *E* earlier document but published on or after the international filing date *L* document which may throw doubts on priority claim(s) or which is cited to establish the publication date of another citation or other special reason (as specified) *O* document referring to an oral disclosure, use, exhibition or other means *P* document published prior to the international filing date but later than the priority date claimed	*T* later document published after the international filing date or priority date and not in conflict with the application but cited to understand the principle or theory underlying the invention *X* document of particular relevance; the claimed invention cannot be considered novel or cannot be considered to involve an inventive step when the document is taken alone *Y* document of particular relevance; the claimed invention cannot be considered to involve an inventive step when the document is combined with one or more other such documents, such combination being obvious to a person skilled in the art. *&* document member of the same patent family			
Date of the actual completion of the international search <p style="text-align: center;">16 April 2004</p>		Date of mailing of the international search report <p style="text-align: center;">03/05/2004</p>		
Name and mailing address of the ISA European Patent Office, P.B. 5818 Patentlaan 2 NL - 2280 HV Rijswijk Tel. (+31-70) 340-2040, Tx. 31 651 epo nl, Fax: (+31-70) 340-3016		Authorized officer <p style="text-align: center;">Maicas, J</p>		

1

INTERNATIONAL SEARCH REPORT

International Application No
PCT/IB 03/05927

C.(Continuation) DOCUMENTS CONSIDERED TO BE RELEVANT		
Category *	Citation of document, with indication, where appropriate, of the relevant passages	Relevant to claim No.
A	<p>HAARTSEN J: "BLUETOOTH - THE UNIVERSAL RADIO INTERFACE FOR AD HOC, WIRELESS CONNECTIVITY" ON - ERICSSON REVIEW, ERICSSON. STOCKHOLM, SE, no. 3, 1998, pages 110-117, XP000783249 ISSN: 0014-0171</p> <p>-----</p>	
A	<p>EP 1 251 721 A (ELES SEMICONDUCTOR EQUIPMENT S) 23 October 2002 (2002-10-23)</p> <p>-----</p>	
A	<p>ZHANG W ET AL: "On Improving the Performance of Bluetooth Networks THROUGH DYNAMIC ROLE MANAGEMENT" ONLINE, May 2001 (2001-05), XP002198269 Retrieved from the Internet: URL:http://www.cse.psu.edu/{gcao/paper/bluetooth.ps></p> <p>-----</p>	

INTERNATIONAL SEARCH REPORT

International Application No
PCT/IB 03/05927

Patent document cited in search report		Publication date	Patent family member(s)	Publication date
EP 1176762	A	30-01-2002	KR 2002009283 A	01-02-2002
			CN 1335698 A	13-02-2002
			DE 60100379 D1	24-07-2003
			EP 1176762 A1	30-01-2002
			JP 3421017 B2	30-06-2003
			JP 2002111689 A	12-04-2002
			TW 519808 B	01-02-2003
			US 2002055978 A1	09-05-2002

JP 10126861	A	15-05-1998	NONE	

EP 1251721	A	23-10-2002	EP 1251721 A1	23-10-2002
