

(19) World Intellectual Property Organization
International Bureau



(43) International Publication Date
12 September 2002 (12.09.2002)

PCT

(10) International Publication Number
WO 02/071535 A1

- (51) International Patent Classification⁷: **H01Q 1/24**, 9/04, 5/00 (72) Inventor: **BOYLE, Kevin, R.**; Prof. Holstlaan 6, NL-5656 AA Eindhoven (NL).
- (21) International Application Number: PCT/IB02/00473 (74) Agent: **SCOTT, Kevin, J.**; Internationaal Octrooibureau B.V., Prof. Holstlaan 6, NL-5656 AA Eindhoven (NL).
- (22) International Filing Date: 15 February 2002 (15.02.2002) (81) Designated States (*national*): CN, JP, KR.
- (25) Filing Language: English (84) Designated States (*regional*): European patent (AT, BE, CH, CY, DE, DK, ES, FI, FR, GB, GR, IE, IT, LU, MC, NL, PT, SE, TR).
- (26) Publication Language: English
- (30) Priority Data: 0105440.2 6 March 2001 (06.03.2001) GB Published: — with international search report
- (71) Applicant: **KONINKLIJKE PHILIPS ELECTRONICS N.V.** [NL/NL]; Groenewoudseweg 1, NL-5621 BA Eindhoven (NL). For two-letter codes and other abbreviations, refer to the "Guidance Notes on Codes and Abbreviations" appearing at the beginning of each regular issue of the PCT Gazette.

(54) Title: ANTENNA ARRANGEMENT

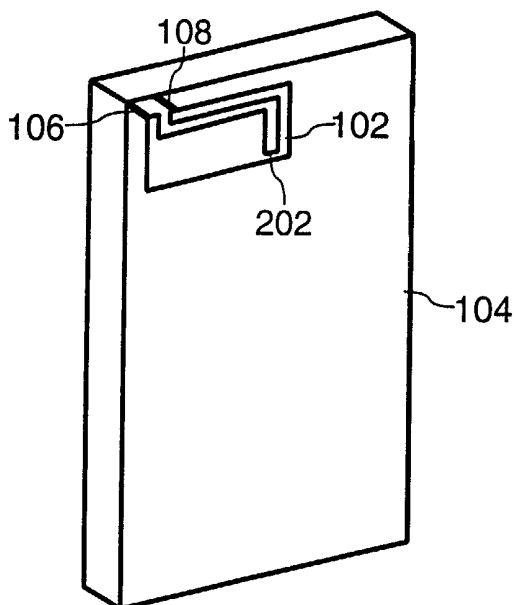

(57) Abstract: An antenna arrangement comprises a patch conductor (102) supported substantially parallel to a ground plane (104). The patch conductor includes first (106) and second (108) connection points, for connection to radio circuitry, and further incorporates a slot (202) between the first and second points. The antenna can be operated in a plurality of modes by variations in the impedances connected to the first and second points. For example, if signals are fed to the first point (106) then a high frequency antenna is obtained by connecting the second point (108) to ground and a low frequency antenna by leaving the second point (108) open circuit. A wide range of embodiments having alternative connection arrangements are possible.

WO 02/071535 A1

DESCRIPTION

ANTENNA ARRANGEMENTTechnical Field

5 The present invention relates to an antenna arrangement comprising a substantially planar patch conductor, and to a radio communications apparatus incorporating such an arrangement.

Background Art

10 Wireless terminals, such as mobile phone handsets, typically incorporate either an external antenna, such as a normal mode helix or meander line antenna, or an internal antenna, such as a Planar Inverted-F Antenna (PIFA) or similar.

 Such antennas are small (relative to a wavelength) and therefore, owing to the fundamental limits of small antennas, narrowband. However, cellular
15 radio communication systems typically have a fractional bandwidth of 10% or more. To achieve such a bandwidth from a PIFA for example requires a considerable volume, there being a direct relationship between the bandwidth of a patch antenna and its volume, but such a volume is not readily available with the current trends towards small handsets. Further, PIFAs become
20 reactive at resonance as the patch height is increased, which is necessary to improve bandwidth.

 A further problem occurs when a dual band antenna is required. In this case two resonators are required within the same structure, which means that only part of the available antenna area is used effectively at each frequency.
25 Since the bandwidth of an antenna is related to its size, even more volume is required to provide wideband operation in two bands. An example of such an antenna is disclosed in European patent application EP 0,997,974, in which two PIFA antennas are fed from a common point and share a common shorting pin. The low frequency element is wrapped around the high frequency
30 element, which therefore means that the high frequency element must be small compared to the total antenna size (and therefore narrow band).

Our co-pending unpublished United Kingdom patent application 0101667.4 (Applicant's reference PHGB 010009) discloses a variation on a conventional PIFA in which a slot is introduced in the PIFA between the feed pin and shorting pin. Such an arrangement provided an antenna having
5 substantially improved impedance characteristics while requiring a smaller volume than a conventional PIFA.

Disclosure of Invention

An object of the present invention is to provide an improved planar antenna arrangement.

10 According to a first aspect of the present invention there is provided an antenna arrangement comprising a substantially planar patch conductor, having first and second connection points for connection to radio circuitry and a slot incorporated between the points, and a ground plane, wherein the antenna arrangement operates in a plurality of modes depending on the
15 impedances of the circuitry connected to the first and second connection points.

By varying the impedances connected to the connection points, the current fed into the antenna may follow different routes, thereby providing different modes of operation. The modes may have different resonant
20 frequencies and/or different impedances. The impedances may include short and open circuits, which may be provided by switches or passive circuits. Further connection points may be provided, and the radio circuitry may comprise a distributed diplexer. All of these arrangements have the advantage of enabling a reduced antenna volume compared to a PIFA of equivalent
25 volume by making full use of the patch conductor in all modes.

According to a second aspect of the present invention there is provided a radio communications apparatus including an antenna arrangement made in accordance with the present invention.

The present invention is based upon the recognition, not present in the
30 prior art, that by enabling the impedances connected to points on the patch conductor of a PIFA to be varied, dual-band and multi-band antennas making full use of the patch area in all bands are enabled.

Brief Description of Drawings

Embodiments of the present invention will now be described, by way of example, with reference to the accompanying drawings, wherein:

Figure 1 is a perspective view of a PIFA mounted on a handset;

5 Figure 2 is a perspective view of a slotted planar antenna mounted on a handset;

Figure 3 is a graph of simulated return loss S_{11} in dB against frequency f in MHz for the antenna of Figure 2, with the first pin fed and the second pin grounded;

10 Figure 4 is a Smith chart showing the simulated impedance of the antenna of Figure 2 over the frequency range 800 to 3000MHz, with the first pin fed and the second pin grounded;

Figure 5 is a graph of simulated return loss S_{11} in dB against frequency f in MHz for the antenna of Figure 2, with the second pin fed and the first pin
15 grounded;

Figure 6 is a Smith chart showing the simulated impedance of the antenna of Figure 2 over the frequency range 800 to 3000MHz, with the second pin fed and the first pin grounded;

Figure 7 is a graph of simulated return loss S_{11} in dB against frequency
20 f in MHz for the antenna of Figure 2, with the first pin fed and the second pin open circuit;

Figure 8 is a Smith chart showing the simulated impedance of the antenna of Figure 2 over the frequency range 800 to 3000MHz, with the first pin fed and the second pin open circuit;

25 Figure 9 is a graph of simulated return loss S_{11} in dB against frequency f in MHz for the antenna of Figure 2, with the second pin fed and the first pin open circuit;

Figure 10 is a Smith chart showing the simulated impedance of the antenna of Figure 2 over the frequency range 800 to 3000MHz, with the
30 second pin fed and the first pin open circuit; and

Figure 11 to 15 are plan views of further embodiments of the present invention.

In the drawings the same reference numerals have been used to indicate corresponding features.

Modes for Carrying Out the Invention

A perspective view of a PIFA mounted on a handset is shown in Figure 1. The PIFA comprises a rectangular patch conductor 102 supported parallel to a ground plane 104 forming part of the handset. The antenna is fed via a feed pin 106, and connected to the ground plane 104 by a shorting pin 108.

In a typical example embodiment of a PIFA the patch conductor 102 has dimensions 20×10mm and is located 8mm above the ground plane 104 which measures 40×100×1mm. The feed pin 106 is located at a corner of both the patch conductor 102 and ground plane 104, and the shorting pin 108 is separated from the feed pin 106 by 3mm.

It is well known that the impedance of a PIFA is inductive. One explanation for this is provided by considering the currents on the feed and shorting pins 106,108 as the sum of differential mode (equal and oppositely directed, non-radiating) and common mode (equally directed, radiating) currents. For the differential mode currents, the feed and shorting pins 106,108 form a short-circuit transmission line, which has an inductive reactance because of its very short length relative to a wavelength (8mm, or 0.05λ at 2GHz, in the embodiment shown in Figure 1).

Figure 2 is a perspective view of a variation on the standard PIFA, disclosed in our co-pending unpublished United Kingdom patent application GB0101667.4 (Applicant's reference PHGB 010009), in which a slot 202 is provided in the patch conductor 102 between the feed pin 106 and shorting pin 108. The presence of the slot affects the differential mode impedance of the antenna arrangement by increasing the length of the short circuit transmission line formed by the feed pin 106 and shorting pin 108, which enables the inductive component of the impedance of the antenna to be significantly reduced. This is because the slot 202 greatly increases the length of the short-circuit transmission line formed by the feed and shorting pins 106,108, thereby enabling the impedance of the transmission line to be made less inductive.

This arrangement is therefore known as a Differentially Slotted PIFA (DS-PIFA).

It was also shown in the above-referenced patent application that the presence of the slot provides an impedance transformation. This is because the DS-PIFA can be considered to be similar to a very short, heavily top-loaded folded monopole. The impedance transformation is by a factor of approximately four if the slot 202 is centrally located in the patch conductor 102. An asymmetrical arrangement of the slot 202 on the patch conductor 102 can be used to adjust this impedance transformation, enabling the resistive impedance of the antenna to be adjusted for better matching to a 50Ω circuit.

In a first embodiment of the present invention, the shorting pin 108 is not connected directly to the ground plane 104. Instead, an input signal to the antenna may be fed to either of the pins 106,108, with the other pin either being left open circuit or being connected directly to the ground plane 104. Hence, the pins will now be referred to as a first pin 106 and a second pin 108. As mentioned above, the patch conductor 102 has dimensions 20×10mm and is located 8mm above the ground plane 104. The slot 202 is 1mm wide, starts centrally between the two pins 106,108, then runs parallel to the edge of the patch conductor 102 and 0.5mm from its edge.

The return loss S_{11} of this embodiment (without matching) was simulated using the High Frequency Structure Simulator (HFSS), available from Ansoft Corporation, for a number of feeding arrangements. In each case, the results are shown as a graph of the magnitude of S_{11} for frequencies f between 800 and 3000MHz and as a Smith chart illustrating the simulated impedance of the arrangement over the same frequency range.

In a first arrangement of this embodiment, the first pin 106 is fed while the second pin 108 is shorted to the ground plane 104, with simulation results shown in Figures 3 and 4. In a second arrangement, the second pin 108 is fed while the first pin 106 is shorted to the ground plane 104, with simulation results shown in Figures 5 and 6. In both of these arrangements, the antenna behaves as a DS-PIFA in the same way as disclosed in GB0101667.4, and is resonant at a high frequency. The impedance presented depends on which

side of the slot 202 is fed. When the first pin 106 is fed the common mode transformation ratio is low and a low impedance is presented, while when the second pin 108 is fed the common mode transformation ratio is high and a high impedance is presented. This can clearly be seen from comparison of the Smith charts in Figures 4 and 6 respectively.

One way in which the first and second arrangements could be used is disclosed in our co-pending unpublished United Kingdom patent application GB0025709.7 (Applicant's reference PHGB000145) in which a transceiver comprises a transmitter coupled to the first pin 106 and a receiver coupled to the second pin 108 (or vice versa). Such an embodiment can be used in a time division radio system, with circuitry arranged to couple the first pin 106 to the ground plane 104 while the transceiver is receiving and to couple the second pin 108 to the ground plane 104 while the transceiver is transmitting. By suitable positioning of the slot 202, the receiver can be fed by a low impedance while the transmitter can feed a high impedance, improving operation of the transceiver.

Further embodiments could be based on the inclusion of additional features, as disclosed in our co-pending unpublished United Kingdom patent application GB0030741.3 (Applicant's reference PHGB000176), for example the addition of discrete components to the antenna structure.

In a third arrangement of the present invention, the first pin 106 is fed and the second pin 108 is left open circuit, with simulation results shown in Figures 7 and 8. In a fourth arrangement of the present invention, the second pin 108 is fed and the first pin 106 is left open circuit, with simulation results shown in Figures 9 and 10.

It is shown in our co-pending unpublished United Kingdom patent application GB 0105441.0 (Applicant's reference PHGB010033), that a Planar Inverted-L Antenna (PILA) together with an external matching circuit can provide equivalent performance to a dual-band or multi-band PIFA from a reduced antenna volume. This is because the shorting pin in a conventional PIFA performs a matching function, but this match is only effective at one frequency and is at the expense of the match at other frequencies.

The third and fourth arrangements operate as a meandered PILA, since the open circuit pin has little effect. In the third arrangement, where the first pin 106 is fed, the resonant frequency is increased because the narrow section of the patch conductor 102, above and to the right of the slot 202, has little effect
5 because of its small area. In the fourth arrangement, the resonant frequency is reduced because the narrow section of the patch conductor 102 carries current to the wider section, and therefore the full meandered length is resonant.

The simulations described above demonstrate that it is possible to
10 operate a planar antenna in both DS-PIFA and meandered PILA modes. A meandered PIFA could also be used instead of a meandered PILA, as in some of the subsequent embodiments. A range of embodiments of the present invention, all suitable for use as a dual band GSM/DCS antenna, will now be presented to illustrate its practical application.

15 Figure 11 is a plan view of a second embodiment of the present invention. In both bands a RF signal source 302 is fed to the patch conductor 102 via the first pin 106. The second pin 108 is connected to a switch 304. In the low frequency (GSM) mode the switch 304 is open and the antenna operates as a meandered PILA. In the high frequency (DCS) mode the switch
20 304 is closed, connecting the second pin 108 to the ground plane 104, and the antenna operates as a DS-PIFA. In both modes, all of the antenna structure is used (in contrast to dual-band PIFAs such as that disclosed in EP 0,997,974) and therefore increased bandwidths can be produced. This is particularly beneficial for the high frequency band, and will be even more so for UMTS
25 antennas, which need to operate at a higher frequency and over a wider bandwidth.

Figure 12 is a plan view of a third embodiment of the present invention. In both bands a RF signal source 302 is fed to the patch conductor 102 via the first pin 106. The second pin 108 is connected to a first switch 304, and a third
30 pin 402 is provided, connected to a second switch 404. In the low frequency (GSM) mode the first switch 304 is open, the second switch 404 is closed, connecting the third pin 402 to the ground plane 104, and the antenna

operates as a meandered PIFA. In the high frequency (DCS) mode the switches 304,404 are reversed, connecting the second pin 108 to the ground plane 104, and the antenna operates as a DS-PIFA.

Figure 13 is a plan view of a fourth embodiment of the present invention. This is the same as the third embodiment with the addition of a further slot 502 close to the edge of the patch conductor 102. The settings of the switches for the modes are the same as for the third embodiment. The presence of the further slot 502 enables the low frequency mode to operate as a DS-PIFA, with a consequent improvement in its match. The high frequency mode is not significantly affected by the further slot 502 owing to its location close to the perimeter of the patch conductor 102.

In all of the above embodiments where switches are used, the same effect could be obtained by other means. For example, passive equivalents such as tuned circuits may be used. In addition, some or all of the pins not being fed could be reactively loaded instead of being short or open circuited.

Figure 14 is a plan view of a fifth embodiment of the present invention, which requires no switching components by distributing a diplexer between two antenna feeds. In the low frequency (GSM) mode, a GSM signal source 602 is passed by a low-pass filter 604 and fed to the patch conductor 102 via the first pin 106. In the high frequency (DCS) mode, a DCS signal source 606 is passed by a high-pass filter 608 and fed to the patch conductor via the second pin 108. A grounding pin 610 is also provided, connecting the patch conductor 102 and ground plane 104. In operation, in the low frequency mode the high-pass filter 608 presents a high impedance to GSM signals and the antenna operates as a meandered PIFA. In the high frequency mode the low-pass filter 604 presents a high impedance to DCS signals and the antenna operates as a DS-PIFA. This embodiment has the additional advantage that the antenna provides additional isolation between the GSM and DCS ports.

Figure 15 is a plan view of a sixth embodiment of the present invention. This is the same as the fifth embodiment with the addition of a further slot 502 close to the edge of the patch conductor 102. This modifies the low frequency mode to operate as a DS-PIFA, providing improved impedance characteristics.

From reading the present disclosure, other modifications will be apparent to persons skilled in the art. Such modifications may involve other features which are already known in the design, manufacture and use of antenna arrangements and component parts thereof, and which may be used
5 instead of or in addition to features already described herein.

In the present specification and claims the word "a" or "an" preceding an element does not exclude the presence of a plurality of such elements. Further, the word "comprising" does not exclude the presence of other elements or steps than those listed.

CLAIMS

1. An antenna arrangement comprising a substantially planar patch conductor, having first and second connection points for connection to radio circuitry and a slot incorporated between the points, and a ground plane, wherein the antenna arrangement operates in a plurality of modes depending on the impedances of the circuitry connected to the first and second connection points.
2. An arrangement as claimed in claim 1, characterised in that the ground plane is spaced from, and co-extensive with, the patch conductor.
3. An arrangement as claimed in claim 1 or 2, characterised in that the slot is positioned asymmetrically in the patch conductor, thereby providing an impedance transformation.
4. An arrangement as claimed in any one of claims 1 to 3, characterised in that the radio circuitry is arranged to provide a first mode in which a radio signal is fed to the first connection point and the second connection point is grounded and a second mode in which the connections are reversed.
5. An arrangement as claimed in any one of claims 1 to 3, characterised in that the radio circuitry is arranged to provide a first mode in which a radio signal is fed to the first connection point and the second connection point is open circuit and a second mode in which the connections are reversed.
6. An arrangement as claimed in any one of claims 1 to 3, characterised in that the radio circuitry is arranged to feed a radio signal to the first connection point and to provide a first mode in which the second

connection point is grounded and a second mode in which the second connection point is open circuit.

7. An arrangement as claimed in claim 6, characterised in that the
5 radio circuitry include switching means connected between the second connection point and ground to change between first and second modes.

8. An arrangement as claimed in any one of claims 1 to 3,
10 characterised in that the patch conductor includes a third connection point for connection to the radio circuitry.

9. An arrangement as claimed in claim 8, characterised in that a
15 further slot is incorporated in the patch conductor between the first and third connection points.

10. An arrangement as claimed in claim 8 or 9, characterised in that
the radio circuitry comprises a distributed diplexer connected to the first and third connection points.

20 11. A radio communications apparatus including an antenna arrangement as claimed in any one of claims 1 to 10.

1/8

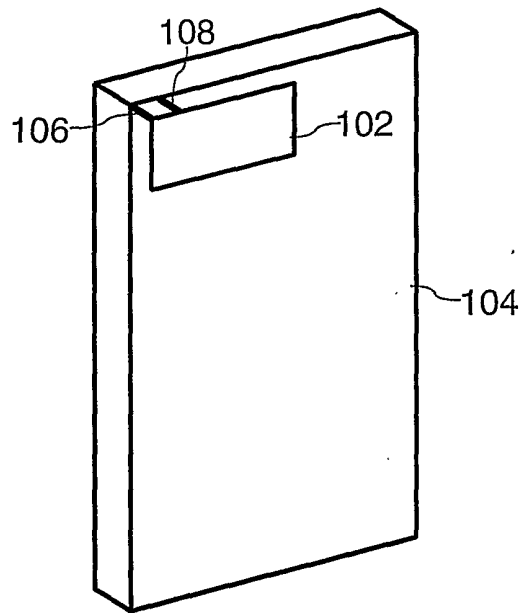

FIG. 1

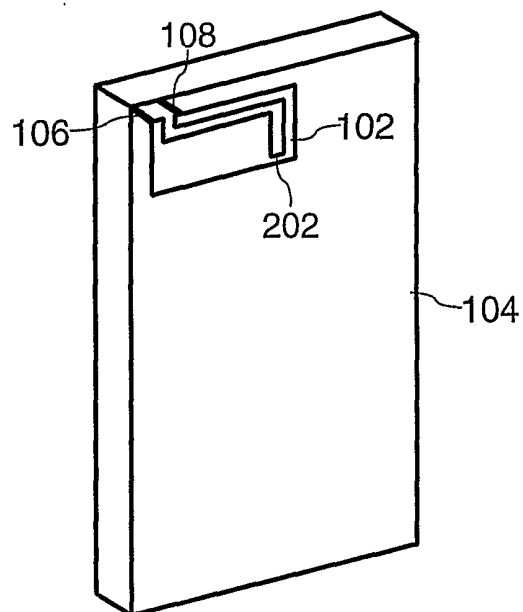

FIG. 2

2/8

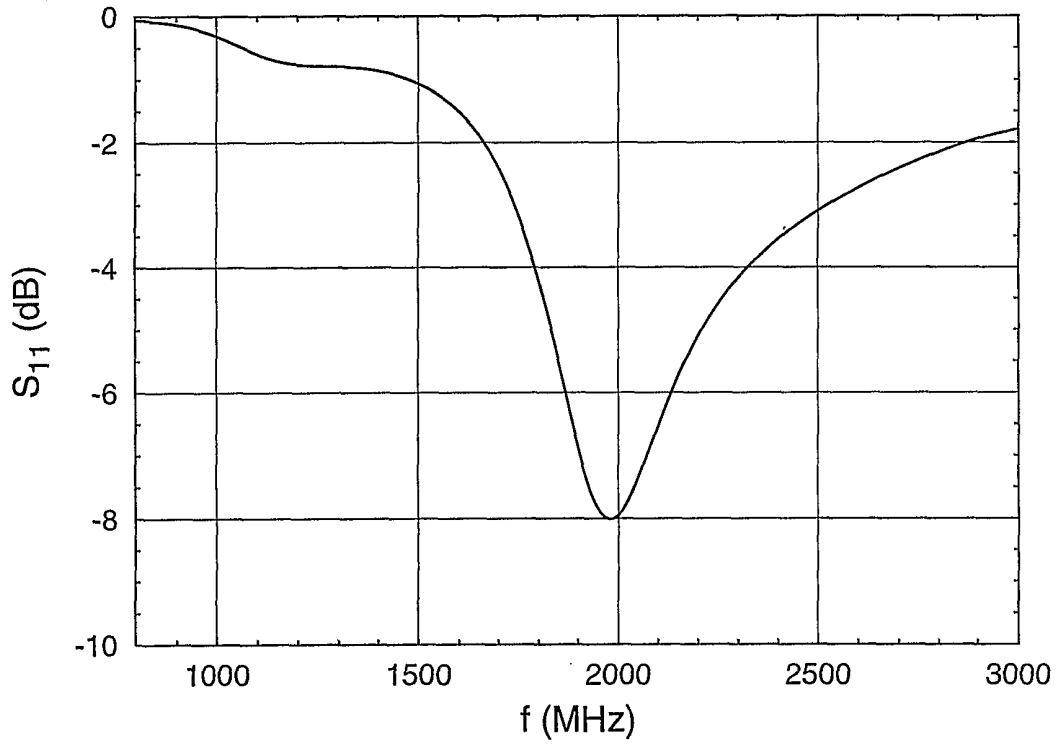

FIG. 3

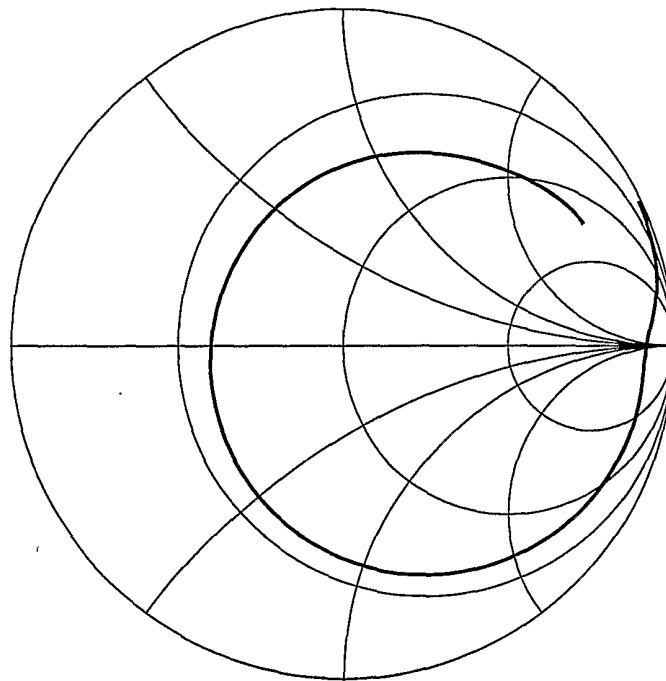

FIG. 4

3/8

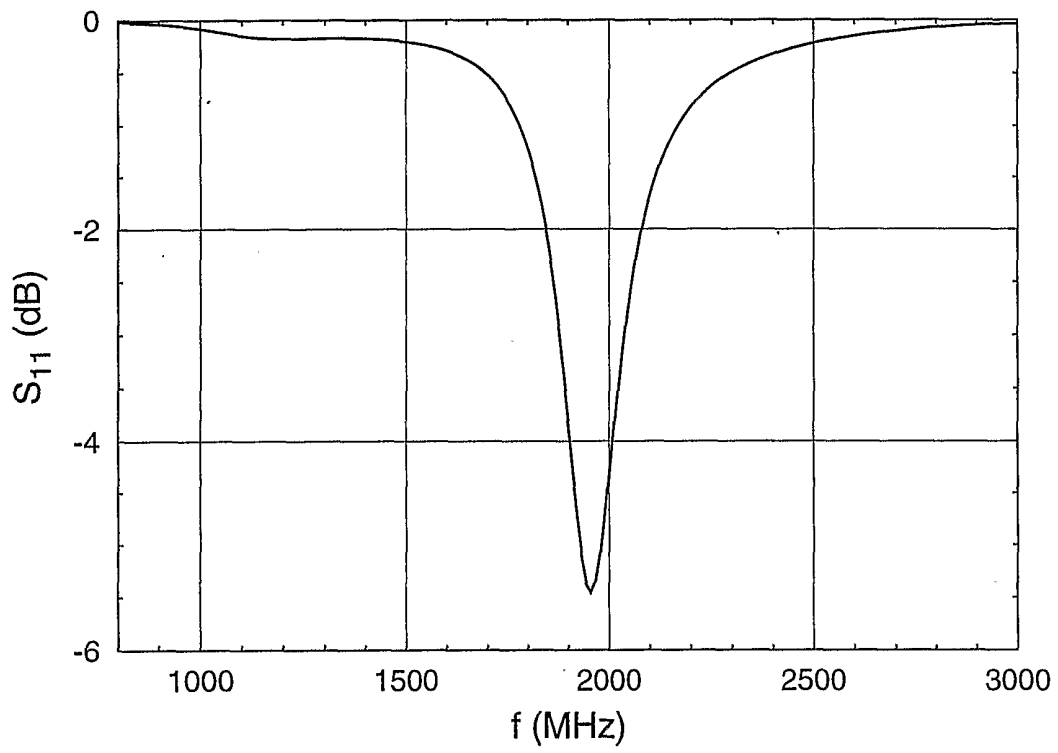

FIG. 5

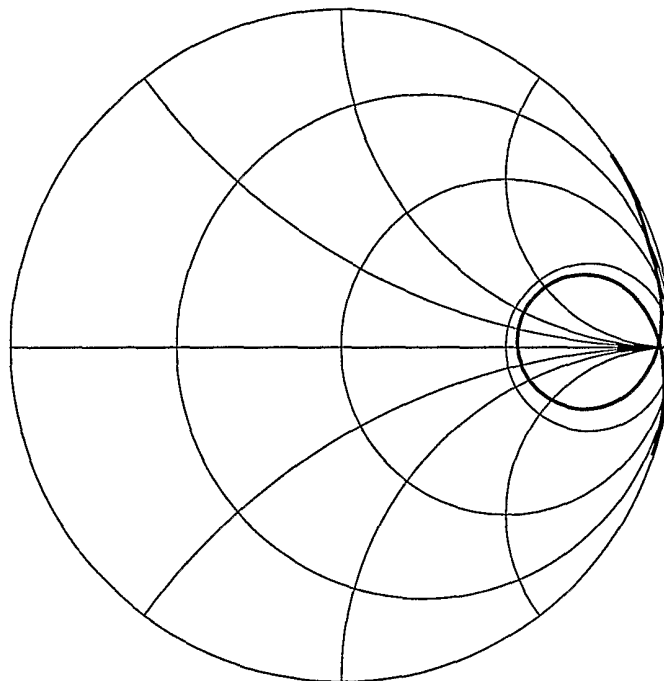

FIG. 6

4/8

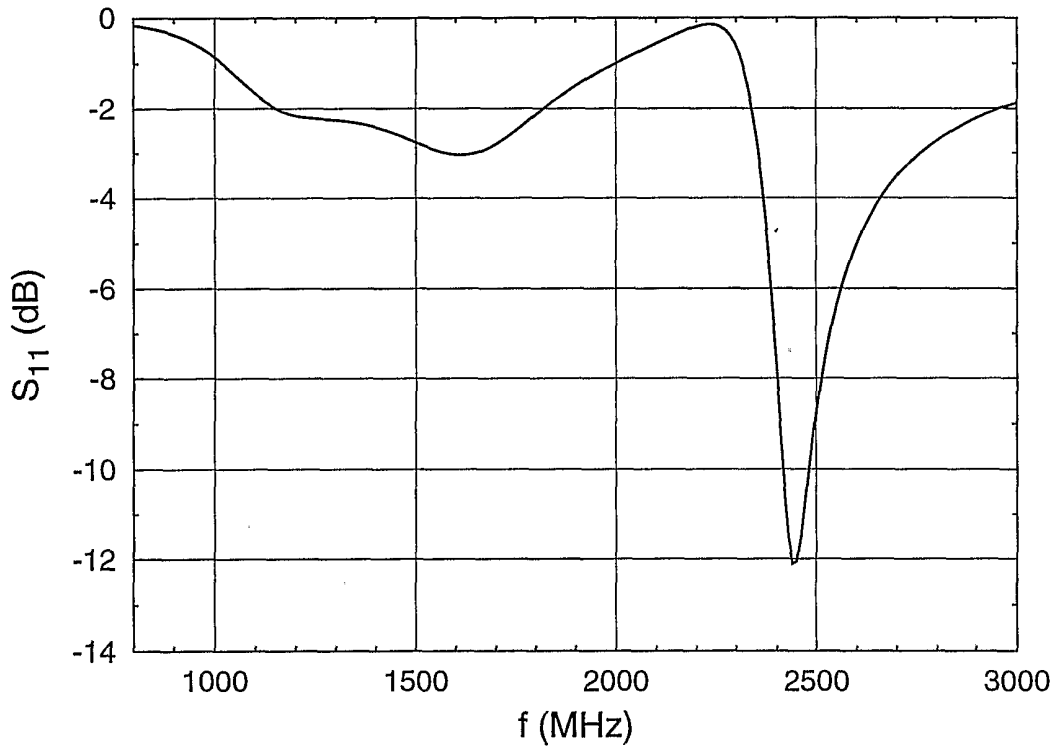

FIG. 7

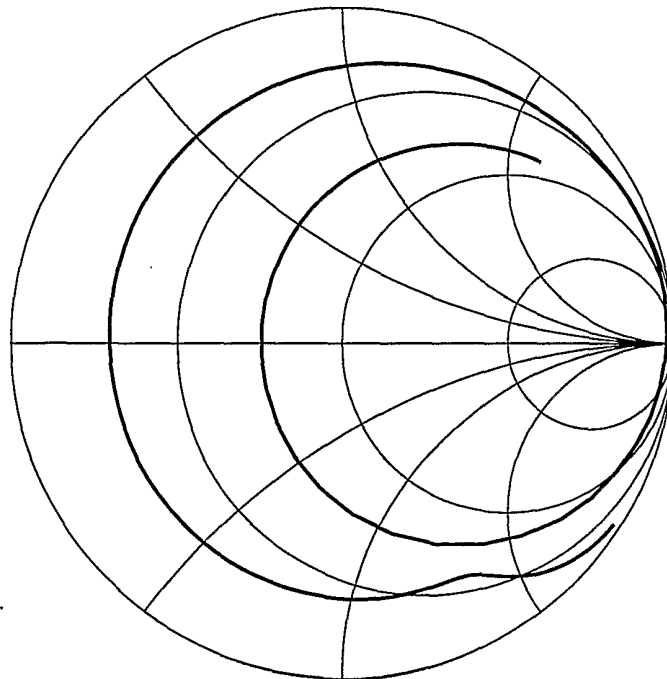

FIG. 8

5/8

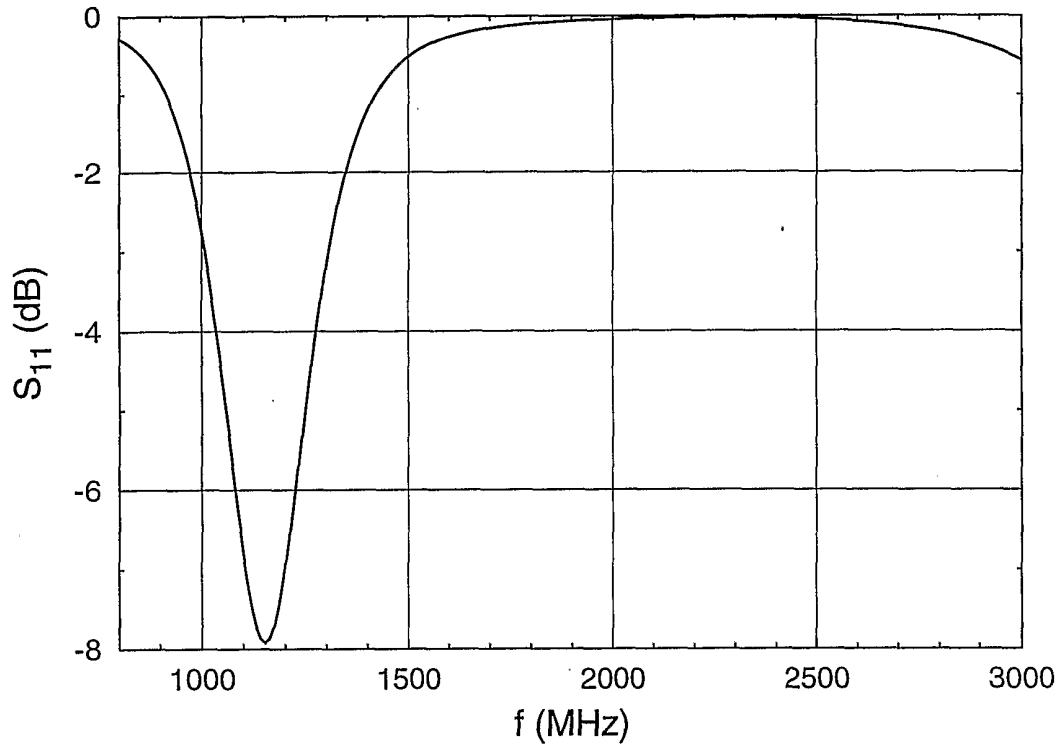

FIG. 9

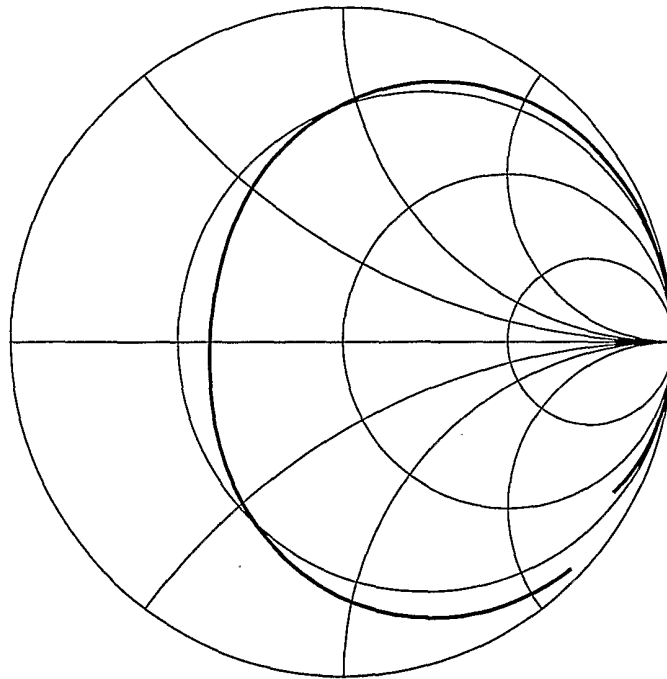

FIG. 10

6/8

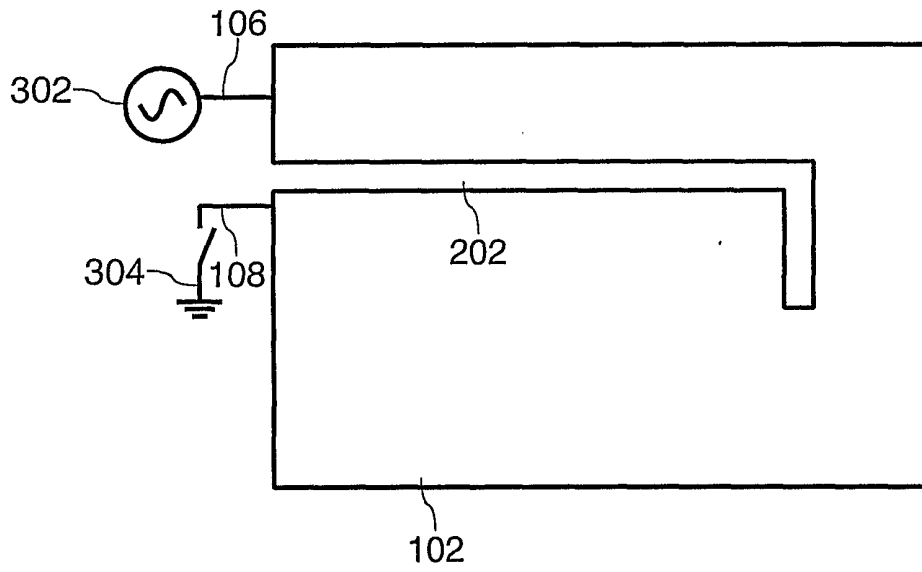

FIG. 11

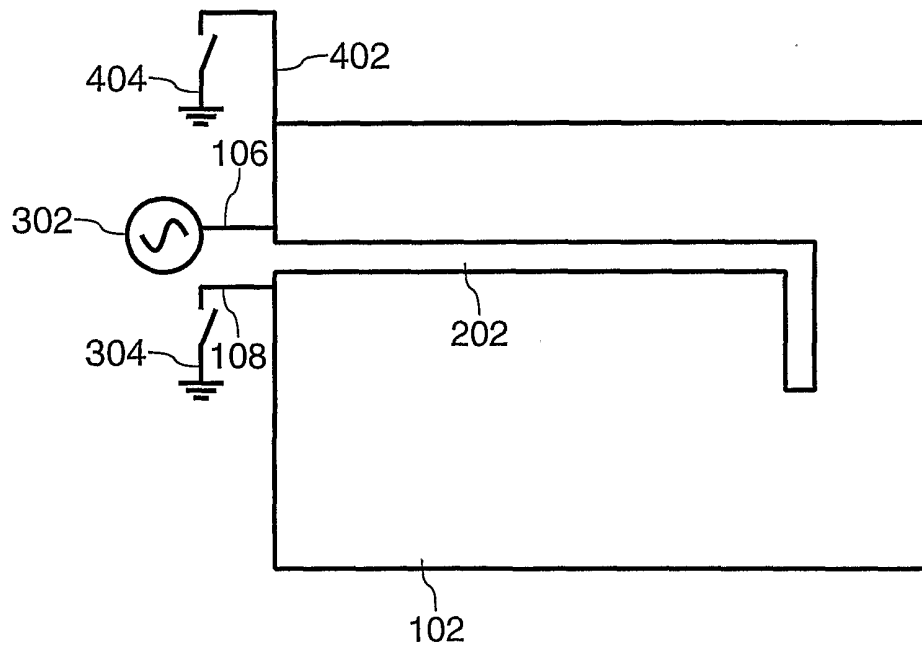

FIG. 12

7/8

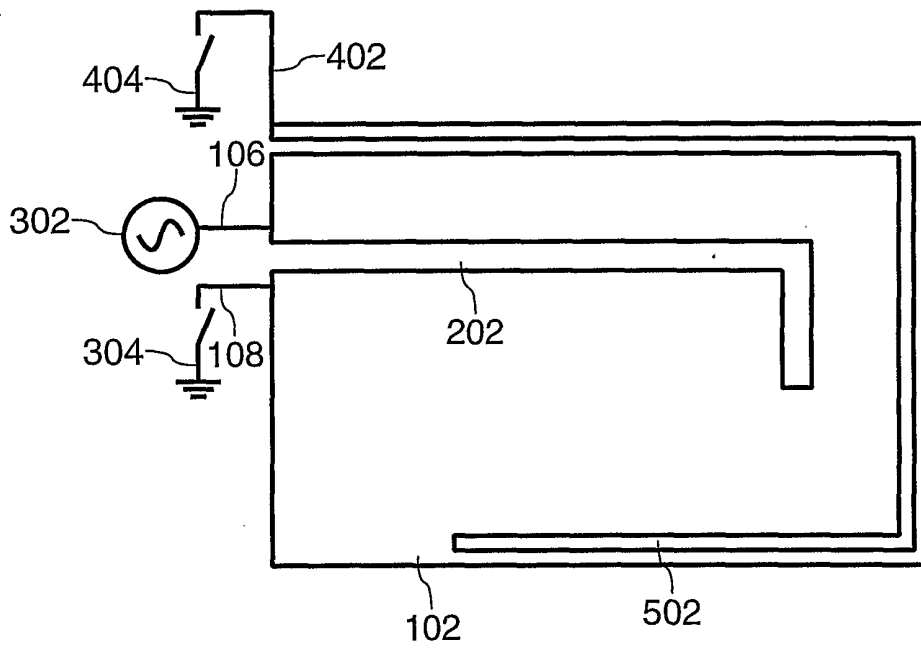

FIG. 13

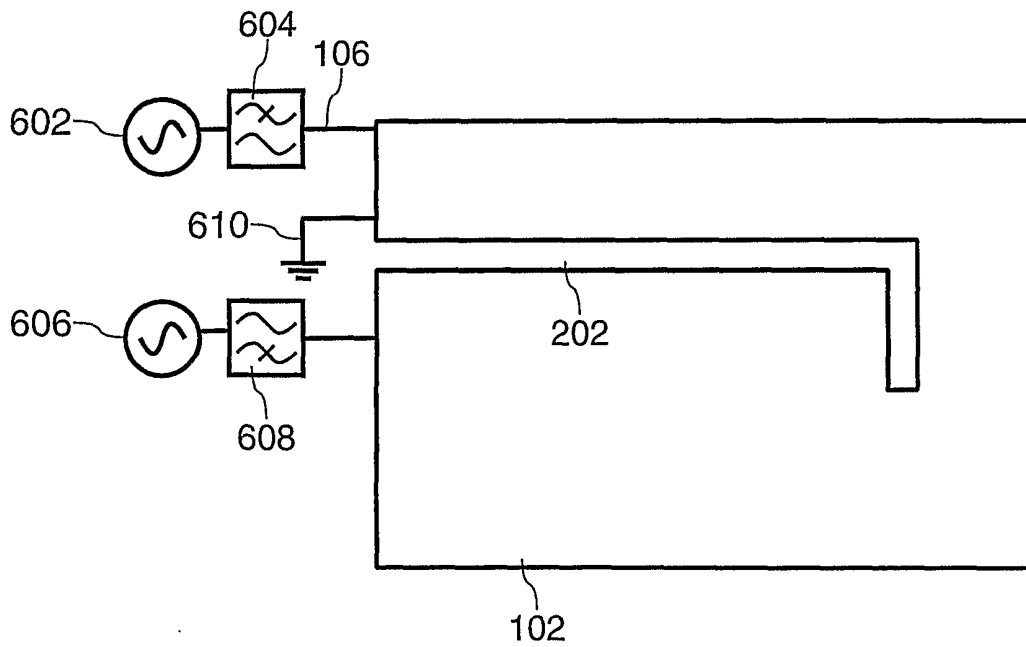

FIG. 14

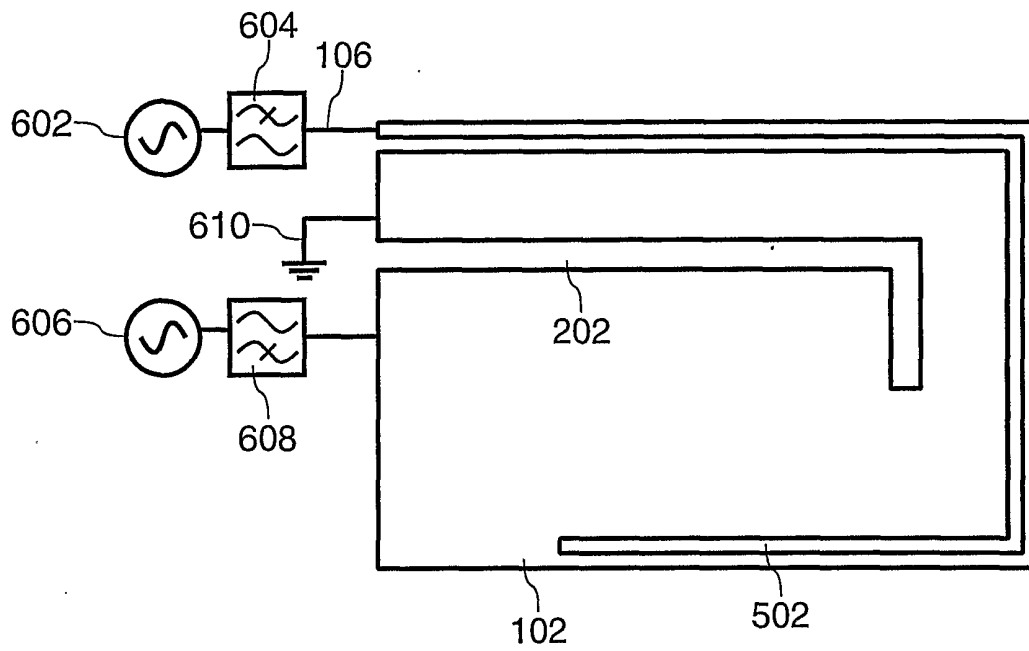

FIG. 15

INTERNATIONAL SEARCH REPORT

International Application No
IB 02/00473

A. CLASSIFICATION OF SUBJECT MATTER
IPC 7 H01Q1/24 H01Q9/04 H01Q5/00

According to International Patent Classification (IPC) or to both national classification and IPC

B. FIELDS SEARCHED

Minimum documentation searched (classification system followed by classification symbols)
IPC 7 H01Q

Documentation searched other than minimum documentation to the extent that such documents are included in the fields searched

Electronic data base consulted during the international search (name of data base and, where practical, search terms used)

WPI Data, EPO-Internal, PAJ

C. DOCUMENTS CONSIDERED TO BE RELEVANT

Category °	Citation of document, with indication, where appropriate, of the relevant passages	Relevant to claim No.
X	EP 0 929 121 A (NOKIA MOBILE PHONES LTD) 14 July 1999 (1999-07-14) column 5, line 20 -column 7, line 39	1-3
Y	PATENT ABSTRACTS OF JAPAN vol. 1998, no. 12, 31 October 1998 (1998-10-31) & JP 10 190345 A (SHARP CORP), 21 July 1998 (1998-07-21) abstract	1-11
Y	PATENT ABSTRACTS OF JAPAN vol. 1997, no. 04, 30 April 1997 (1997-04-30) & JP 08 321716 A (MITSUBISHI ELECTRIC CORP), 3 December 1996 (1996-12-03) abstract	1-11

Further documents are listed in the continuation of box C.

Patent family members are listed in annex.

° Special categories of cited documents :

- *A* document defining the general state of the art which is not considered to be of particular relevance
- *E* earlier document but published on or after the international filing date
- *L* document which may throw doubts on priority claim(s) or which is cited to establish the publication date of another citation or other special reason (as specified)
- *O* document referring to an oral disclosure, use, exhibition or other means
- *P* document published prior to the international filing date but later than the priority date claimed

- *T* later document published after the international filing date or priority date and not in conflict with the application but cited to understand the principle or theory underlying the invention
- *X* document of particular relevance; the claimed invention cannot be considered novel or cannot be considered to involve an inventive step when the document is taken alone
- *Y* document of particular relevance; the claimed invention cannot be considered to involve an inventive step when the document is combined with one or more other such documents, such combination being obvious to a person skilled in the art.
- *G* document member of the same patent family

Date of the actual completion of the international search

3 May 2002

Date of mailing of the international search report

13/05/2002

Name and mailing address of the ISA

European Patent Office, P.B. 5818 Patentlaan 2
NL - 2280 HV Rijswijk
Tel. (+31-70) 340-2040, Tx. 31 651 epo nl,
Fax: (+31-70) 340-3016

Authorized officer

Johansson, R

INTERNATIONAL SEARCH REPORT

In International Application No

PCT/IB 02/00473

C.(Continuation) DOCUMENTS CONSIDERED TO BE RELEVANT		
Category °	Citation of document, with indication, where appropriate, of the relevant passages	Relevant to claim No.
Y	EP 0 993 070 A (NIPPON ELECTRIC CO) 12 April 2000 (2000-04-12) abstract ---	1-11
Y	PATENT ABSTRACTS OF JAPAN vol. 1997, no. 02, 28 February 1997 (1997-02-28) & JP 08 274535 A (MATSUSHITA ELECTRIC IND CO LTD), 18 October 1996 (1996-10-18) abstract ---	1-11
Y	PATENT ABSTRACTS OF JAPAN vol. 016, no. 447 (E-1266), 17 September 1992 (1992-09-17) & JP 04 157908 A (ALPS ELECTRIC CO LTD), 29 May 1992 (1992-05-29) abstract ---	1-11
A	US 6 160 513 A (DAVIDSON BRIAN JAMES ET AL) 12 December 2000 (2000-12-12) abstract ---	1-11
A	EP 0 892 459 A (NOKIA MOBILE PHONES LTD) 20 January 1999 (1999-01-20) abstract ---	1-11
A	EP 1 052 722 A (NOKIA MOBILE PHONES LTD) 15 November 2000 (2000-11-15) abstract ---	1-11
A	DE 198 22 371 A (BOSCH GMBH ROBERT) 25 November 1999 (1999-11-25) abstract ---	1-11
A	PATENT ABSTRACTS OF JAPAN vol. 1998, no. 13, 30 November 1998 (1998-11-30) & JP 10 224142 A (KENWOOD CORP), 21 August 1998 (1998-08-21) abstract ---	1-11
P,Y	EP 1 113 524 A (NOKIA MOBILE PHONES LTD) 4 July 2001 (2001-07-04) abstract ---	1-11
P,Y	US 6 204 819 B1 (SADLER ROBERT A ET AL) 20 March 2001 (2001-03-20) abstract ---	1-11
P,Y	PATENT ABSTRACTS OF JAPAN vol. 2002, no. 02, 2 April 2002 (2002-04-02) & JP 2001 274619 A (NIPPON SOKEN INC; DENSO CORP), 5 October 2001 (2001-10-05) abstract -----	1-11

INTERNATIONAL SEARCH REPORT

Information on patent family members

International Application No

PCT/IB 02/00473

Patent document cited in search report		Publication date	Patent family member(s)	Publication date
EP 0929121	A	14-07-1999	US 5929813 A BR 9900013 A EP 0929121 A1 EP 0929115 A1 JP 2000004116 A US 6025802 A US 6054954 A	27-07-1999 21-12-1999 14-07-1999 14-07-1999 07-01-2000 15-02-2000 25-04-2000
JP 10190345	A	21-07-1998	NONE	
JP 08321716	A	03-12-1996	NONE	
EP 0993070	A	12-04-2000	JP 2000114856 A AU 5137999 A CN 1254205 A EP 0993070 A1 US 6255994 B1	21-04-2000 06-04-2000 24-05-2000 12-04-2000 03-07-2001
JP 08274535	A	18-10-1996	NONE	
JP 04157908	A	29-05-1992	JP 2640872 B2	13-08-1997
US 6160513	A	12-12-2000	GB 2332780 A AU 1773699 A DE 69804023 D1 EP 1051773 A1 GB 2347275 A WO 9933144 A1 JP 2001527309 T	30-06-1999 12-07-1999 04-04-2002 15-11-2000 30-08-2000 01-07-1999 25-12-2001
EP 0892459	A	20-01-1999	FI 972897 A EP 0892459 A1 FI 981571 A US 6140966 A	09-01-1999 20-01-1999 09-01-1999 31-10-2000
EP 1052722	A	15-11-2000	GB 2349982 A EP 1052722 A2 JP 2000332530 A	15-11-2000 15-11-2000 30-11-2000
DE 19822371	A	25-11-1999	DE 19822371 A1 WO 9960662 A1 EP 1086509 A1	25-11-1999 25-11-1999 28-03-2001
JP 10224142	A	21-08-1998	NONE	
EP 1113524	A	04-07-2001	FI 20001023 A EP 1113524 A2 US 2001007445 A1	01-07-2001 04-07-2001 12-07-2001
US 6204819	B1	20-03-2001	AU 5328001 A WO 0191234 A1	03-12-2001 29-11-2001
JP 2001274619	A	05-10-2001	NONE	