

(19)  
(12)

(KR)  
(B1)

(51) 。 Int. Cl. 7  
H01P 7/06

(45)  
(11)  
(24)

2003 01 14  
10 - 0368035  
2002 12 31

(21) 10 - 1999 - 0054178  
(22) 1999 12 01

(65) 2000 - 0049353  
(43) 2000 08 05

(73)

903 - 2

446

2 1923

107 303

(72)

2 1923

107 303

903

102 1306

969 - 1

922 1402

1 1

31 104

8 503

447 - 5

5 201

(74)

:

(54)

GHZ

가

2 , 가 가 1 1 , 가 , 4  
 pling) , 가 가 1 1 , 가 , (Cou

5

1a 1b

2a 2b 1a

3a 3c

4 3b -

5 가

6

7a 7b /

8a 8c , 가

\* \*

20,20a - 20c ; 21 ;

22 ; 23a - 23d ;

24 ; 25 ; 1

26,26a - 26c,32 ; 27 ;

28 ; 2 29 ; 3

30 ; 4 31 ;

33 ; 34 ;

35 ; 36 ;  
 37 ; 40 ;  
 50 ;

GHZ , 가 , ,  
 가 (L) (C) ,  
 (BPF) .  
 (1) 1a 1b  
 (3) , (5) / (5b) , ( )  
 (5a)  
 (1) (5a) (5b)  
 (Coupling) (1a - 1c) 2a 2b (1a - 1c)  
 (7) (11) (7) 가  
 (Capacitor or Inductor) (9)  
 , 가 가 .  
 (1a - 1c) (Coupling) (5b)  
 가 가 ,  
 (Tuning)  
 가 가 .  
 (Cavity) 가 가  
 가 .  
 /

가

가

가  
(Coupling Capacitance)

가  
가

가 , 4 , 2 , 1 1 ,  
 가 , 가 가 1 1 ,  
 (Coupling)  
 가 2 가

(rectangular trench), (notch type)

가 "U" (island) , L - 3 C -

4

/

가

( )

가

3a , 3c  
5

가 , 4 3b -  
7a 7b , 6

/

(20) 3 5

(22) , 4

(23a - 23d)

(21)

(24)

(23a - 23d), (32)

(rectangular trench), (23a - 23d) (notch type), 가 (22)

(24) (26) (20) (40) (25)가 (22) (Coupling) 5 8a  
가 LC (26) (40)

(20) (26) (40) (22)

1 (25)가 (24)

(20) (23a - 23d) 2 6  
(24) 2 (28)가

8a 8c (28) 2 (20a,20b) (23b,23d)  
2 (26a - 26c) , 2 (28) (32)가 (23b,23d)

(20a - 20c) (20a - 20c) (23b,23d)

8a 8c 3 (50) 가  
(20a - 20c) 4

(50) (23b,23d) (31)  
(20a 20b, 20b 20c) (32)가 가 ( ) (27)

8a 8c 33 (26a - 26c) ( )  
32 , 35 , 36 , 37 , 34 (20a - 20c)

가 (32) 가 가

und) , 7a 7b / (gro  
(open)

(20a,20c) / (35,36) 7a (23d)  
23b) "U" (24) 3 (29)가 /  
(35,36)가 3 (29) (L - Coupling) 3 (29)가 DC

, (20a,20c) / (35,36) 7b (23d  
 23b) (24) 4 (30)가 . /  
 (35,36)가 4 (30) 가 (30)가 / (35,  
 36) (50) (C - Coupling) . , 가

가

가

가

가

가

4

1/7

가

가

가

(57)

1.

, 4

4

1

(Coupling)

가

가

1

가

2

4

2.

3.

1 , , (rectangular trench), (notch type)

4.

1 , 가  
3

5.

4 , 3 "U"

6.

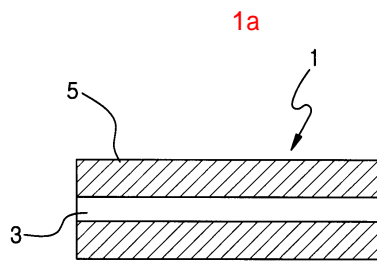

1b

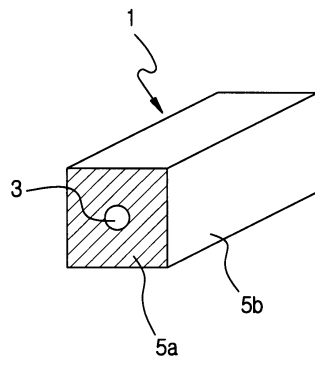

2a

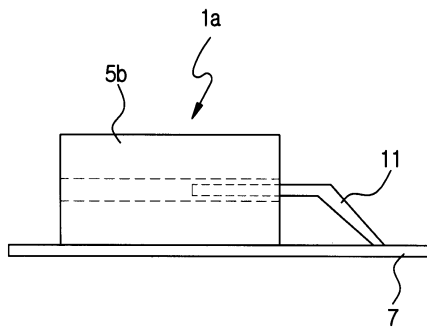

2b

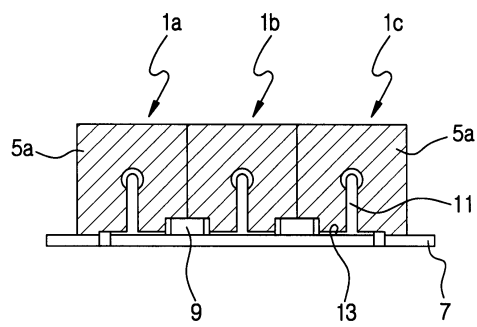



3a

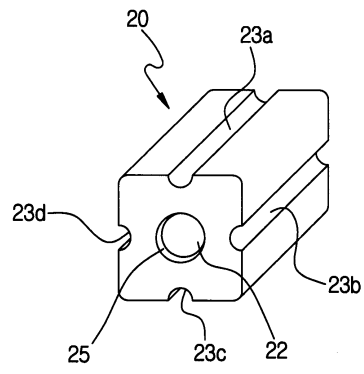

3b

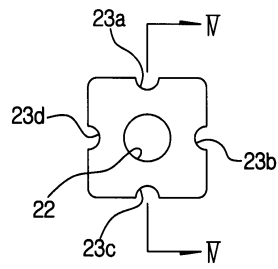

3c

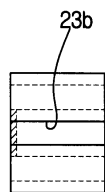

4

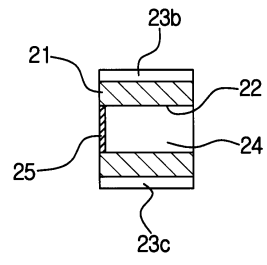

5

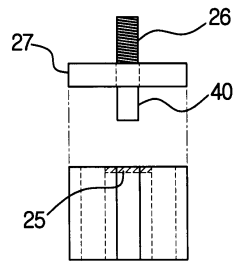

6

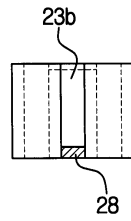

7a

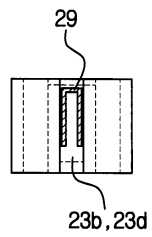



8c

